



DUAL-BAND RF SYNTHESIZER WITH INTEGRATED VCOs FOR WIRELESS COMMUNICATIONS

FEATURES

- Dual-band RF synthesizers
 - RF1: 900 MHz to 1.8 GHz
 - RF2: 750 MHz to 1.5 GHz
- IF synthesizer
 - IF: 62.5 to 1000 MHz
- Integrated VCOs, loop filters, varactors, and resonators
- Minimal (2) number of external components required
- Low phase noise
- Programmable powerdown modes
- 1 μ A standby current
- 18 mA typical supply current
- 2.7 to 3.6 V operation
- Packages: 24-pin TSSOP, 28-lead MLP package (MLP)

Applications

- Dual-band communications
- Digital cellular telephones GSM 850, E-GSM 900, DCS 1800, PCS 1900
- Digital cordless phones
- Analog cordless phones
- Wireless local loop

Description

The Si4133 is a monolithic integrated circuit that performs both IF and dual-band RF synthesis for wireless communications applications. The Si4133 includes three VCOs, loop filters, reference and VCO dividers, and phase detectors. Divider and powerdown settings are programmable with a three-wire serial interface.

Functional Block Diagram

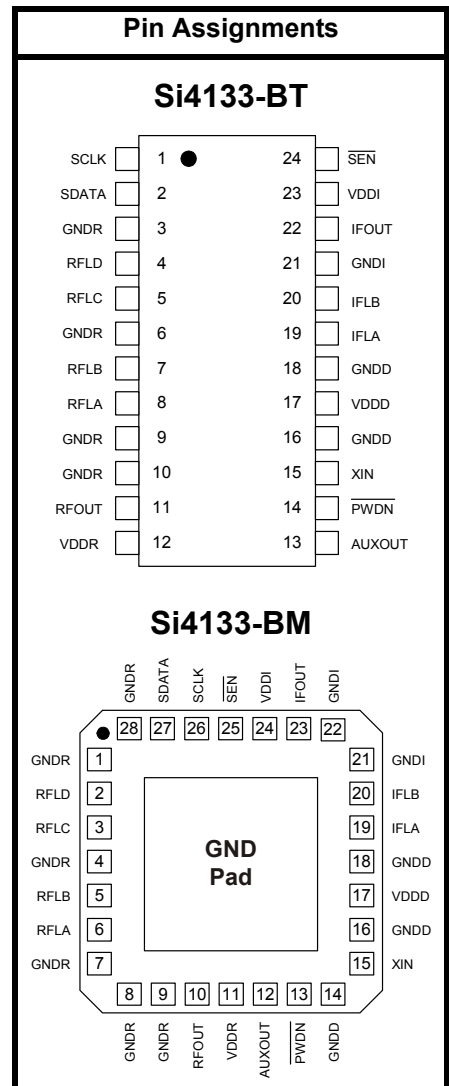
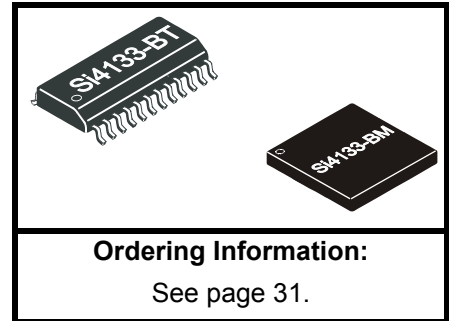
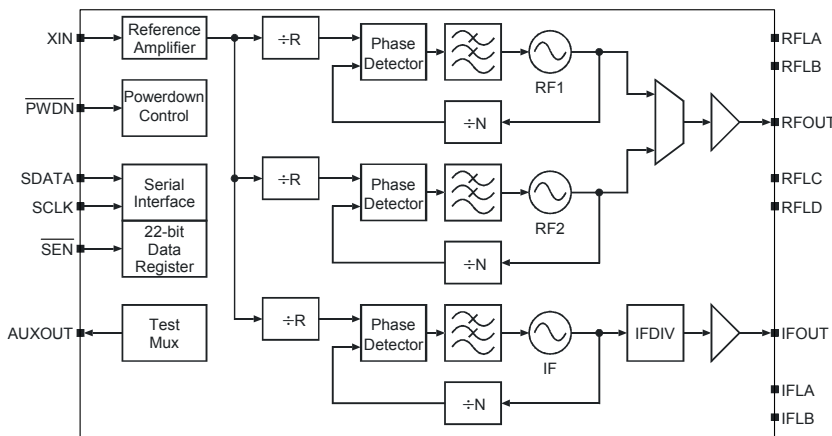

Patents pending

TABLE OF CONTENTS

<u>Section</u>	<u>Page</u>
Electrical Specifications	4
Typical Application Circuits	15
Functional Description	16
Serial Interface	16
Setting the VCO Center Frequencies	16
Extended Frequency Operation	17
Self-Tuning Algorithm	17
Output Frequencies	18
PLL Loop Dynamics	18
RF and IF Outputs	19
Reference Frequency Amplifier	19
Powerdown Modes	19
Auxiliary Output (AUXOUT)	20
Control Registers	21
Pin Descriptions: Si4133-BT	27
Pin Descriptions: Si4133-BM	29
Ordering Guide	31
Si4133 Derivative Devices	31
Package Outline: Si4133-BT	32
Package Outline: Si4133-BM	33
Document Change List	34
Contact Information	36



Electrical Specifications

Table 1. Recommended Operating Conditions

Parameter	Symbol	Test Condition	Min	Typ	Max	Unit
Ambient Temperature	T_A		-40	25	85	°C
Supply Voltage	V_{DD}		2.7	3.0	3.6	V
Supply Voltages Difference	V_{Δ}	$(V_{DDR} - V_{DDD}),$ $(V_{DDI} - V_{DDD})$	-0.3	—	0.3	V

Note: All minimum and maximum specifications are guaranteed and apply across the recommended operating conditions. Typical values apply at nominal supply voltages and an operating temperature of 25 °C unless otherwise stated.

Table 2. Absolute Maximum Ratings^{1,2}

Parameter	Symbol	Value	Unit
DC Supply Voltage	V_{DD}	-0.5 to 4.0	V
Input Current ³	I_{IN}	±10	mA
Input Voltage ³	V_{IN}	-0.3 to $V_{DD}+0.3$	V
Storage Temperature Range	T_{STG}	-55 to 150	°C

Notes:

1. Permanent device damage may occur if the above Absolute Maximum Ratings are exceeded. Functional operation should be restricted to the conditions as specified in the operational sections of this data sheet. Exposure to absolute maximum rating conditions for extended periods may affect device reliability.
2. **This device is a high performance RF integrated circuit with an ESD rating of < 2 kV. Handling and assembly of this device should only be done at ESD-protected workstations.**
3. For signals SCLK, SDATA, SEN, PWDN and XIN.

Table 3. DC Characteristics $(V_{DD} = 2.7 \text{ to } 3.6 \text{ V}, T_A = -40 \text{ to } 85 \text{ }^\circ\text{C})$

Parameter	Symbol	Test Condition	Min	Typ	Max	Unit
Total Supply Current ¹		RF1 and IF operating	—	18	27	mA
RF1 Mode Supply Current ¹			—	10	16	mA
RF2 Mode Supply Current ¹			—	9	16	mA
IF Mode Supply Current ¹			—	8	13	mA
Standby Current		$\overline{\text{PWDN}} = 0$	—	1	—	μA
High Level Input Voltage ²	V_{IH}		$0.7 V_{DD}$	—	—	V
Low Level Input Voltage ²	V_{IL}		—	—	$0.3 V_{DD}$	V
High Level Input Current ²	I_{IH}	$V_{IH} = 3.6 \text{ V},$ $V_{DD} = 3.6 \text{ V}$	-10	—	10	μA
Low Level Input Current ²	I_{IL}	$V_{IL} = 0 \text{ V},$ $V_{DD} = 3.6 \text{ V}$	-10	—	10	μA
High Level Output Voltage ³	V_{OH}	$I_{OH} = -500 \mu\text{A}$	$V_{DD} - 0.4$	—	—	V
Low Level Output Voltage ³	V_{OL}	$I_{OH} = 500 \mu\text{A}$	—	—	0.4	V

Notes:

1. RF1 = 1.6 GHz, RF2 = 1.1 GHz, IFOUT = 550 MHz, LPWR = 0.
2. For signals SCLK, SDATA, $\overline{\text{SEN}}$, and $\overline{\text{PWDN}}$.
3. For signal AUXOUT.



Table 4. Serial Interface Timing
 ($V_{DD} = 2.7$ to 3.6 V, $T_A = -40$ to 85 °C)

Parameter ¹	Symbol	Test Condition	Min	Typ	Max	Unit
SCLK Cycle Time	t_{clk}	Figure 1	40	—	—	ns
SCLK Rise Time	t_r	Figure 1	—	—	50	ns
SCLK Fall Time	t_f	Figure 1	—	—	50	ns
SCLK High Time	t_h	Figure 1	10	—	—	ns
SCLK Low Time	t_l	Figure 1	10	—	—	ns
SDATA Setup Time to SCLK \uparrow ²	t_{su}	Figure 2	5	—	—	ns
SDATA Hold Time from SCLK \uparrow ²	t_{hold}	Figure 2	0	—	—	ns
$\overline{SEN}\downarrow$ to SCLK \uparrow Delay Time ²	t_{en1}	Figure 2	10	—	—	ns
SCLK \uparrow to $\overline{SEN}\uparrow$ Delay Time ²	t_{en2}	Figure 2	12	—	—	ns
$\overline{SEN}\uparrow$ to SCLK \uparrow Delay Time ²	t_{en3}	Figure 2	12	—	—	ns
SEN Pulse Width	t_w	Figure 2	10	—	—	ns

Notes:

1. All timing is referenced to the 50% level of the waveforms unless otherwise noted.
2. Timing is not referenced to 50% level of the waveform. See Figure 2.

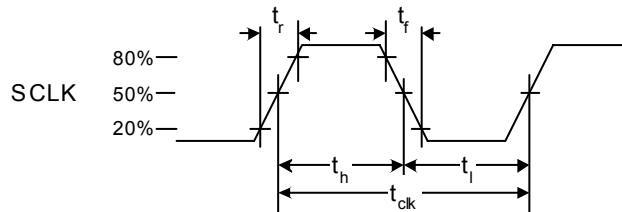

Figure 1. SCLK Timing Diagram

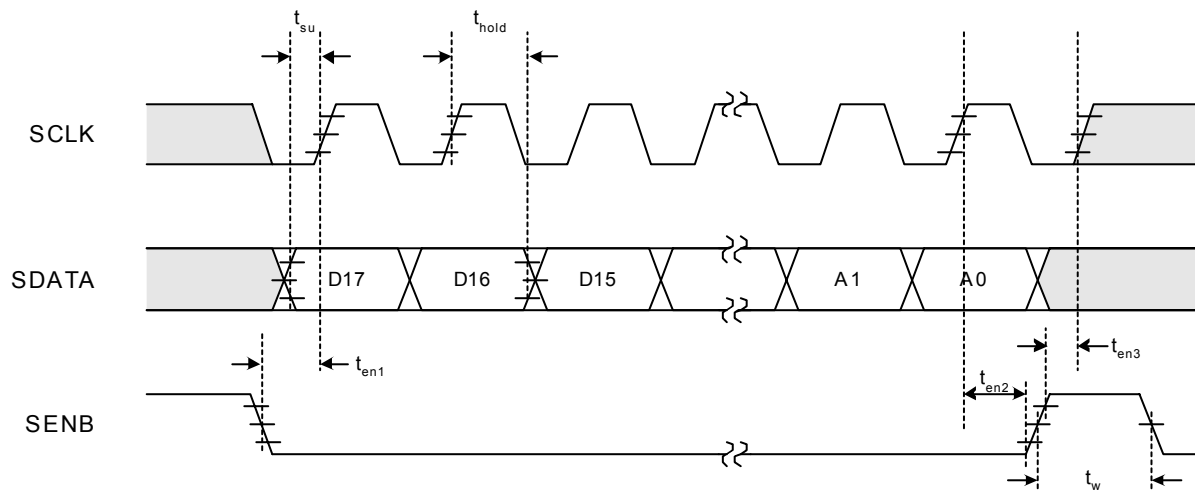

Figure 2. Serial Interface Timing Diagram

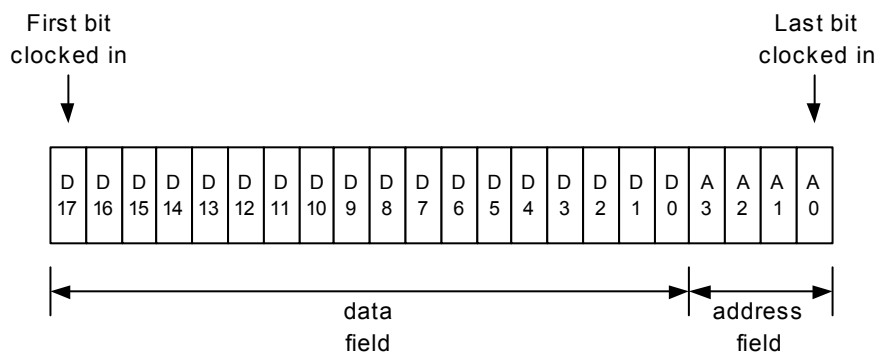

Figure 3. Serial Word Format

Table 5. RF and IF Synthesizer Characteristics(V_{DD} = 2.7 to 3.6 V, T_A = -40 to 85 °C)

Parameter ¹	Symbol	Test Condition	Min	Typ	Max	Unit
XIN Input Frequency	f _{REF}		2	—	26	MHz
Reference Amplifier Sensitivity	V _{REF}		0.5	—	V _{DD} +0.3 V	V _{PP}
Phase Detector Update Frequency	f _φ	f _φ = f _{REF} /R	0.010	—	1.0	MHz
RF1 VCO Center Frequency Range	f _{CEN}		947	—	1720	MHz
RF1 VCO Tuning Range ²		Extended frequency operation	1850	—	2050	MHz
RF2 VCO Center Frequency Range	f _{CEN}		789	—	1429	MHz
RF Tuning Range from f _{CEN}		Note: L _{EXT} ±10%	-5	—	5	%
IF VCO Center Frequency Range	f _{CEN}		526	—	952	MHz
IFOUT Tuning Range		with IFDIV	62.5	—	1000	MHz
IFOUT Tuning Range from f _{CEN}		Note: L _{EXT} ±10%	-5	—	5	%
RF1 VCO Pushing		Open loop	—	500	—	kHz/V
RF2 VCO Pushing			—	400	—	kHz/V
IF VCO Pushing			—	300	—	kHz/V
RF1 VCO Pulling		VSWR = 2:1, all phases, open loop	—	400	—	kHz _{PP}
RF2 VCO Pulling			—	300	—	kHz _{PP}
IF VCO Pulling			—	100	—	kHz _{PP}
RF1 Phase Noise		1 MHz offset	—	-132	—	dBc/Hz
RF1 Integrated Phase Error		10 Hz to 100 kHz	—	0.9	—	degrees rms
RF2 Phase Noise		1 MHz offset	—	-134	—	dBc/Hz
RF2 Integrated Phase Error		10 Hz to 100 kHz	—	0.7	—	degrees rms
IF Phase Noise		100 kHz offset	—	-117	—	dBc/Hz
IF Integrated Phase Error		100 Hz to 100 kHz	—	0.4	—	degrees rms

Notes:

- f_φ = 200 kHz, RF1 = 1.6 GHz, RF2 = 1.2 GHz, IFOUT = 550 MHz, LPWR = 0, for all parameters unless otherwise noted.
- Extended frequency operation only. V_{DD} ≥ 3.0 V, MLP only, VCO Tuning Range fixed by directly shorting the RFLA and RFLB pins. See Application Note 41 for more details on the Si4133 extended frequency operation.
- From powerup request (P_{WDN}↑ or S_{EN}↑ during a write of 1 to bits PDIB and PDRB in Register 2) to RF and IF synthesizers ready (settled to within 0.1 ppm frequency error).
- From powerdown request (P_{WDN}↓, or S_{EN}↑ during a write of 0 to bits PDIB and PDRB in Register 2) to supply current equal to I_{P_{WDN}}.

Table 5. RF and IF Synthesizer Characteristics (Continued)(V_{DD} = 2.7 to 3.6 V, T_A = -40 to 85 °C)

Parameter ¹	Symbol	Test Condition	Min	Typ	Max	Unit
RF1 Harmonic Suppression		Second Harmonic	—	-26	-20	dBc
RF2 Harmonic Suppression			—	-26	-20	dBc
IF Harmonic Suppression			—	-26	-20	dBc
RFOUT Power Level		Z _L = 50 Ω	-8	-3	1	dBm
RFOUT Power Level ²		Z _L = 50 Ω, RF1 active, Extended frequency operation	-14	-7	1	dBm
IFOUT Power Level		Z _L = 50 Ω	-8	-4	0	dBm
RF1 Output Reference Spurs		Offset = 200 kHz	—	-65	—	dBc
		Offset = 400 kHz	—	-71	—	dBc
		Offset = 600 kHz	—	-75	—	dBc
RF2 Output Reference Spurs		Offset = 200 kHz	—	-65	—	dBc
		Offset = 400 kHz	—	-71	—	dBc
		Offset = 600 kHz	—	-75	—	dBc
Powerup Request to Synthesizer Ready ³ Time	t _{pup}	Figures 4, 5	—	40/f _φ	50/f _φ	
Powerdown Request to Synthesizer Off ⁴ Time	t _{pdn}	Figures 4, 5	—	—	100	ns

Notes:

- f_φ = 200 kHz, RF1 = 1.6 GHz, RF2 = 1.2 GHz, IFOUT = 550 MHz, LPWR = 0, for all parameters unless otherwise noted.
- Extended frequency operation only. V_{DD} ≥ 3.0 V, MLP only, VCO Tuning Range fixed by directly shorting the RFLA and RFLB pins. See Application Note 41 for more details on the Si4133 extended frequency operation.
- From powerup request (PWRN↑ or SEN↑ during a write of 1 to bits PDIB and PDRB in Register 2) to RF and IF synthesizers ready (settled to within 0.1 ppm frequency error).
- From powerdown request (PWRN↓, or SEN↑ during a write of 0 to bits PDIB and PDRB in Register 2) to supply current equal to I_{PWRN}.



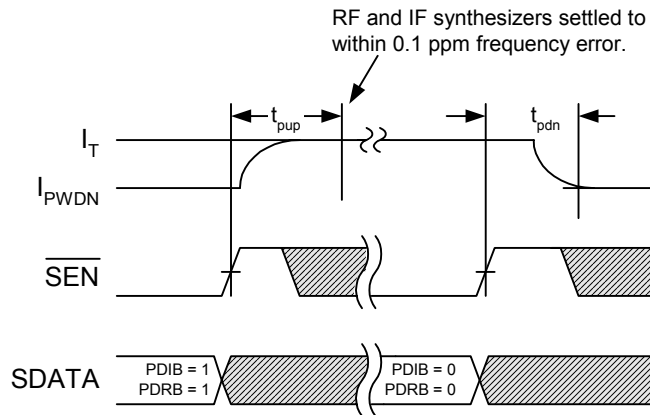

Figure 4. Software Power Management Timing Diagram

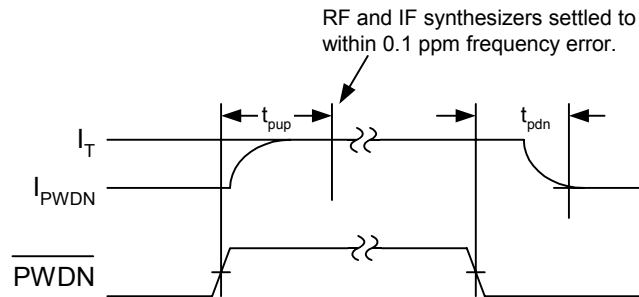

Figure 5. Hardware Power Management Timing Diagram

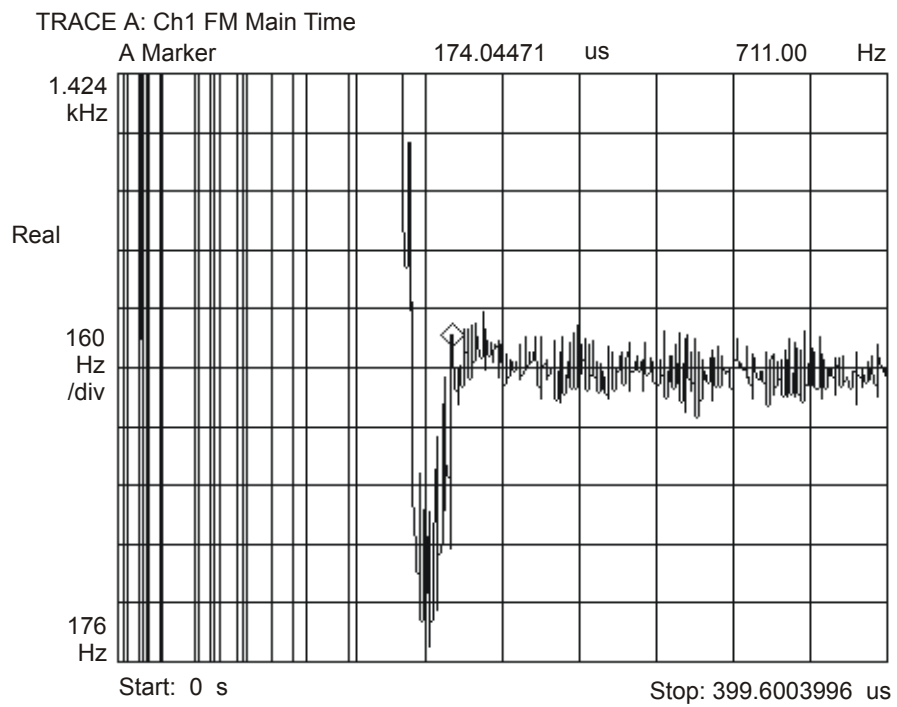

Figure 6. Typical Transient Response RF1 at 1.6 GHz with 200 kHz Phase Detector Update Frequency

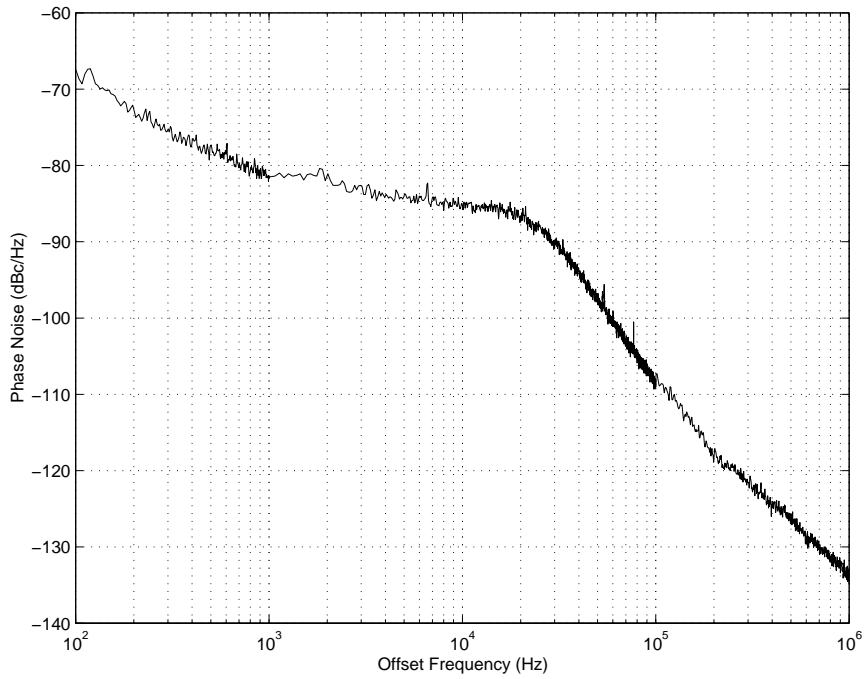

Figure 7. Typical RF1 Phase Noise at 1.6 GHz with 200 kHz Phase Detector Update Frequency

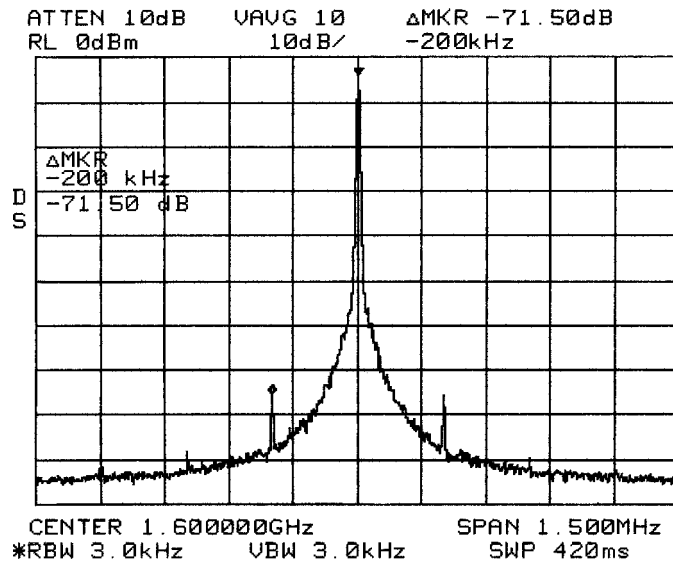
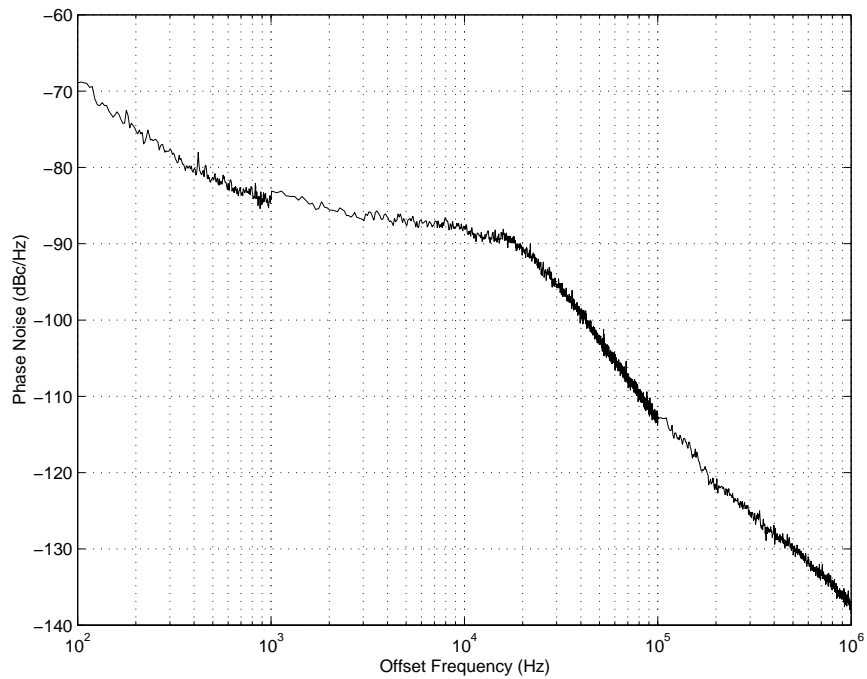
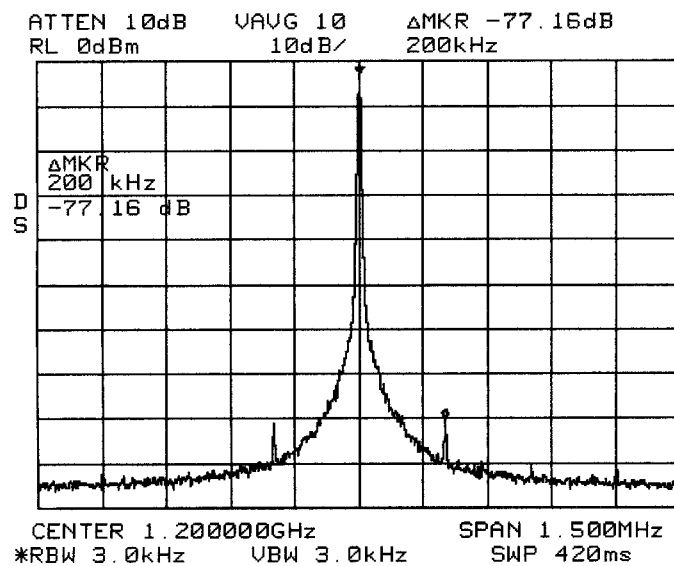

Figure 8. Typical RF1 Spurious Response at 1.6 GHz with 200 kHz Phase Detector Update Frequency



**Figure 9. Typical RF2 Phase Noise at 1.2 GHz
with 200 kHz Phase Detector Update Frequency**



**Figure 10. Typical RF2 Spurious Response at 1.2 GHz
with 200 kHz Phase Detector Update Frequency**

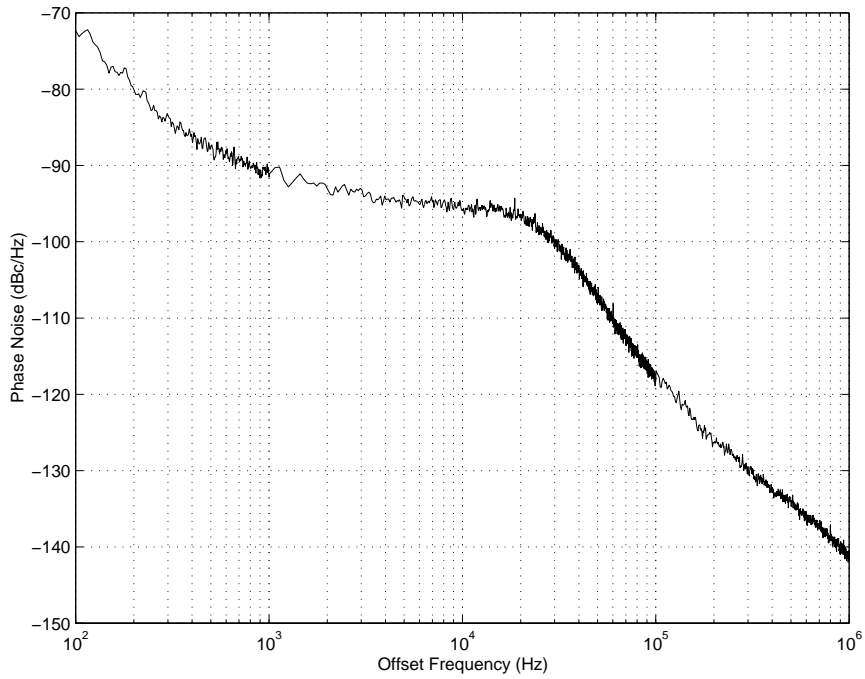

Figure 11. Typical IF Phase Noise at 550 MHz with 200 kHz Phase Detector Update Frequency

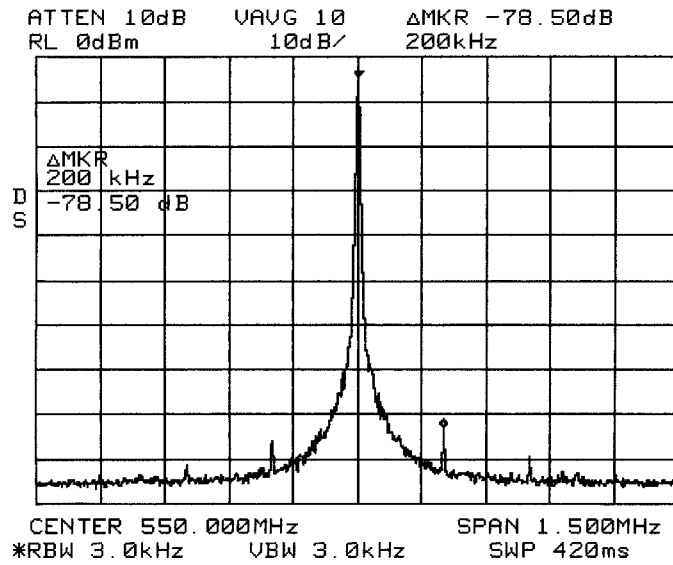
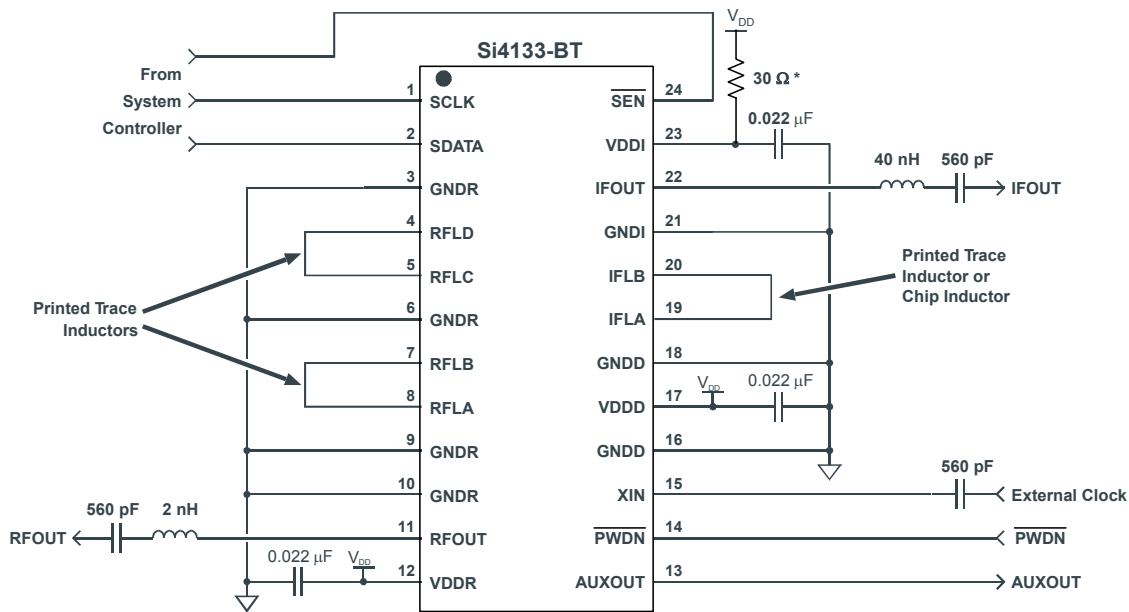

Figure 12. IF Spurious Response at 550 MHz with 200 kHz Phase Detector Update Frequency

Typical Application Circuits



* Add 30 Ω series resistance if using IF output divide values 2, 4, or 8.

Figure 13. Si4133-BT

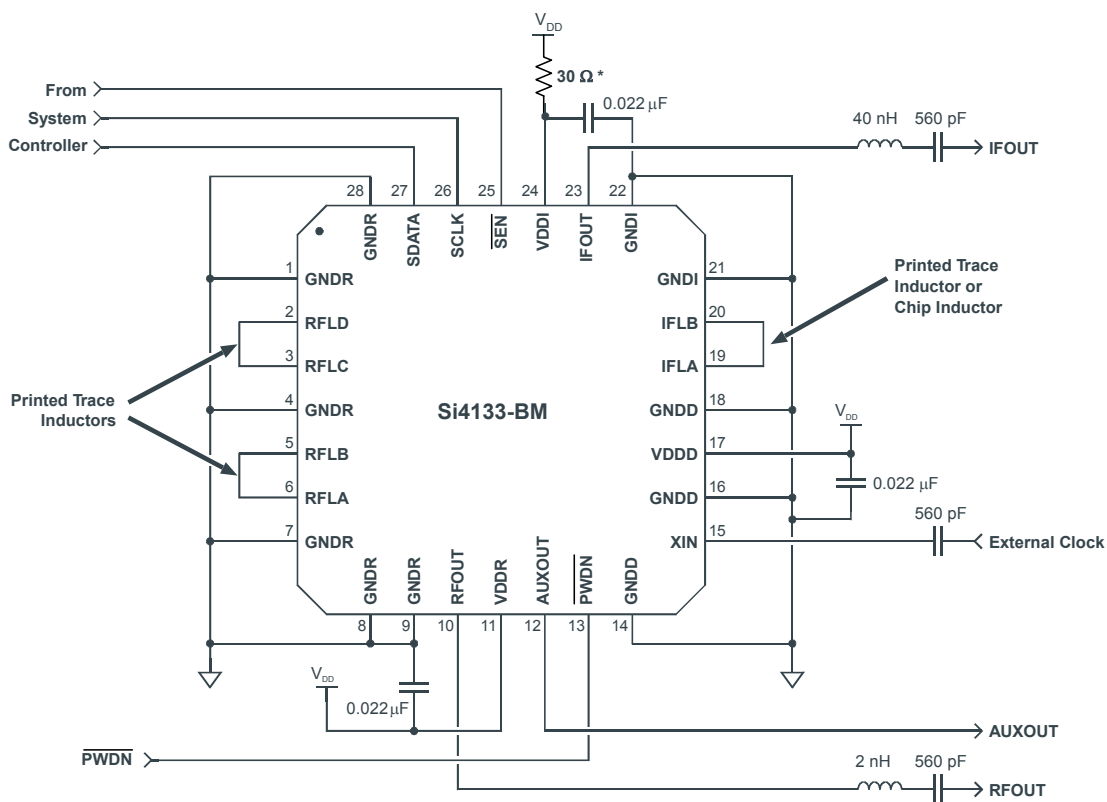

* Add 30 Ω series resistance if using IF output divide values 2, 4, or 8.

Figure 14. Si4133-BM

Functional Description

The Si4133 is a monolithic integrated circuit that performs IF and dual-band RF synthesis for wireless communications applications. This integrated circuit (IC), with minimal external components, completes the frequency synthesis function necessary for RF communications systems.

The Si4133 has three complete phase-locked loops (PLLs) with integrated voltage-controlled oscillators (VCOs). The low phase noise of the VCOs makes the Si4133 suitable for demanding wireless communications applications. Phase detectors, loop filters, and reference and output frequency dividers are integrated. The IC is programmed with a three-wire serial interface.

Two PLLs are provided for dual-band RF synthesis. These RF PLLs are multiplexed so that only one PLL is active at a time, as determined by the setting of an internal register. The active PLL is the last one to be written. The center frequency of the VCO in each PLL is set by the value of an external inductance. Inaccuracies in these inductances are compensated for by the self-tuning algorithm. The algorithm is run after powerup or after a change in the programmed output frequency.

Each RF PLL, when active, can adjust the RF output frequency by $\pm 5\%$ of its VCO's center frequency. Because the two VCOs can be set to have widely separated center frequencies, the RF output can be programmed to service two widely separated frequency bands by programming the corresponding N-Divider. One RF VCO is optimized to have its center frequency set between 947 MHz and 1.72 GHz, while the second RF VCO is optimized to have its center frequency set between 789 MHz and 1.429 GHz.

One PLL is provided for IF frequency synthesis. The center frequency of this circuit's VCO is set by the connection of an external inductance. The PLL can adjust the IF output frequency by $\pm 5\%$ of the VCO center frequency. Inaccuracies in the value of the external inductance are compensated for by the Si4133's proprietary self-tuning algorithm. This algorithm is initiated each time the PLL is powered-up (by either the PWDN pin or by software) and/or each time a new output frequency is programmed.

The IF VCO can have its center frequency set as low as 526 MHz and as high as 952 MHz. An IF output divider divides down the IF output frequencies, if needed. The divider is programmable and is capable of dividing by 1, 2, 4, or 8.

The unique PLL architecture used in the Si4133 produces settling (lock) times that are comparable in speed to fractional-N architectures without the high phase noise or spurious modulation effects often associated with those designs.

Serial Interface

A timing diagram for the serial interface is shown in Figure 2 on page 7. Figure 3 on page 7 shows the format of the serial word.

The Si4133 is programmed serially with 22-bit words comprised of 18-bit data fields and 4-bit address fields. When the serial interface is enabled (i.e., when $\overline{\text{SEN}}$ is low) data and address bits on the SDATA pin are clocked into an internal shift register on the rising edge of SCLK. Data in the shift register is then transferred on the rising edge of $\overline{\text{SEN}}$ into the internal data register addressed in the address field. The serial interface is disabled when $\overline{\text{SEN}}$ is high.

Table 12 on page 21 summarizes the data register functions and addresses. The internal shift register ignores leading bits before the 22 required bits.

Setting the VCO Center Frequencies

The PLLs can adjust the IF and RF output frequencies $\pm 5\%$ of the center frequencies of their VCOs. Each center frequency is established by the value of an external inductance connected to the respective VCO. Manufacturing tolerances of $\pm 10\%$ for the external inductances are acceptable. The Si4133 compensates for inaccuracies in each inductance by executing a self-tuning algorithm after PLL powerup or after a change in the programmed output frequency.

Because the total tank inductance is in the low nH range, the inductance of the package must be considered when determining the correct external inductance. The total inductance (L_{TOT}) presented to each VCO is the sum of the external inductance (L_{EXT}) and the package inductance (L_{PKG}). Each VCO has a nominal capacitance (C_{NOM}) in parallel with the total inductance, and the center frequency is as follows:

$$f_{\text{CEN}} = \frac{1}{2\pi\sqrt{L_{\text{TOT}} \times C_{\text{NOM}}}}$$

or

$$f_{\text{CEN}} = \frac{1}{2\pi\sqrt{(L_{\text{PKG}} + L_{\text{EXT}}) \times C_{\text{NOM}}}}$$

Tables 6 and 7 summarize the characteristics of each VCO.

Table 6. Si4133-BT VCO Characteristics

VCO	f _{CEN} Range (MHz)		C _{NOM} (pF)	L _{PKG} (nH)	L _{EXT} Range (nH)	
	Min	Max			Min	Max
RF1	947	1720	4.3	2.0	0.0	4.6
RF2	789	1429	4.8	2.3	0.3	6.2
IF	526	952	6.5	2.1	2.2	12.0

Table 7. Si4133-BM VCO Characteristics

VCO	f _{CEN} Range (MHz)		C _{NOM} (pF)	L _{PKG} (nH)	L _{EXT} Range (nH)	
	Min	Max			Min	Max
RF1	947	1720	4.3	1.5	0.5	5.1
RF2	789	1429	4.8	1.5	1.1	7.0
IF	526	952	6.5	1.6	2.7	12.5

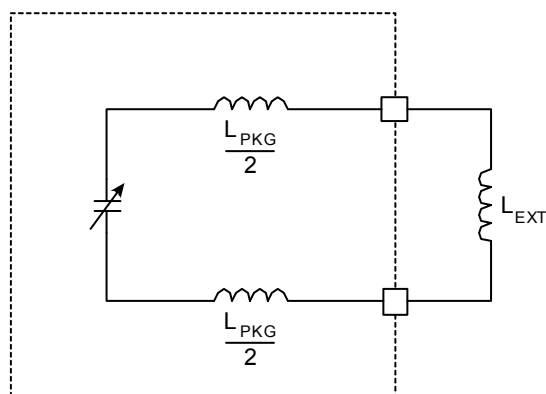

Figure 15. External Inductance Connection

As a design example, consider that the goal is to synthesize frequencies in a 25 MHz band between 1120 and 1145 MHz using the Si4133-BT. The center frequency should be defined as midway between the two extremes, or 1132.5 MHz. The PLL can adjust the VCO output frequency $\pm 5\%$ of the center frequency, or ± 56.6 MHz of 1132.5 MHz (i.e., from approximately 1076 to 1189 MHz). The RF2 VCO has a C_{NOM} of 4.8 pF. A 4.1 nH inductance in parallel with this capacitance yields the required center frequency. An external inductance of 1.8 nH should be connected between RFLC and RFLD as shown in Figure 15. This,

in addition to 2.3 nH of package inductance, presents the correct total inductance to the VCO. In manufacturing, the external inductance can vary $\pm 10\%$ of its nominal value and the Si4133 corrects for the variation with the self-tuning algorithm.

For more information on designing the external trace inductors, refer to Application Note 31: Inductor Design for the Si41xx Synthesizer Family.

Extended Frequency Operation

The Si4133 may operate at an extended frequency range of 1850 MHz to 2050 MHz by connecting the RFLA and RFLB pins directly. For information on configuring the Si4133 for extended frequency operation, refer to Application Note 41: Extended Frequency Operation of Silicon Laboratories Frequency Synthesizers.

Self-Tuning Algorithm

The self-tuning algorithm is initiated immediately after powerup of a PLL or, if the PLL is already powered, after a change in its programmed output frequency. This algorithm attempts to tune the VCO so that its free-running frequency is near the required output frequency. In doing so, the algorithm compensates for manufacturing tolerance errors in the value of the external inductance connected to the VCO. It also reduces the frequency error for which the PLL must correct to get the precise required output frequency. The self-tuning algorithm leaves the VCO oscillating at a frequency in error by somewhat less than 1% of the desired output frequency.

After self-tuning, the PLL controls the VCO oscillation frequency. The PLL completes frequency locking, eliminating any remaining frequency error. From then on, it maintains frequency-lock, compensating for effects of temperature and supply voltage variations.

The Si4133's self-tuning algorithm compensates for component value errors at any temperature within the specified temperature range. However, the ability of the PLL to compensate for drift in component values that occur after self-tuning is limited. For external inductances with temperature coefficients approximately ± 150 ppm/ $^{\circ}\text{C}$, the PLL can maintain lock for changes in temperature of approximately ± 30 $^{\circ}\text{C}$.

Applications where the PLL is regularly powered down or the frequency is periodically reprogrammed minimize or eliminate the potential effects of temperature drift because the VCO is re-tuned in either case. In applications where the ambient temperature can drift substantially after self-tuning, it might be necessary to monitor the lock-detect bar (LDETBar) signal on the AUXOUT pin to determine whether a PLL is about to

run out of locking capability. See “Auxiliary Output (AUXOUT)” for how to select LDET. The LDET signal is low after self-tuning is completed but rises when the IF or RF PLL nears the limit of its compensation range. LDET is also high when either PLL is executing the self-tuning algorithm. The output frequency is still locked when LDET goes high, but the PLL eventually loses lock if the temperature continues to drift in the same direction. Therefore, if LDET goes high both the IF and RF PLLs should be re-tuned promptly by initiating the self-tuning algorithm.

Output Frequencies

The IF and RF output frequencies are set by programming the R- and N-Divider registers. Each PLL has R and N registers so that each can be programmed independently. Programming either the R- or N-Divider register for RF1 or RF2 automatically selects the associated output.

The reference frequency on the XIN pin is divided by R and this signal is input to the PLL’s phase detector. The other input to the phase detector is the PLL’s VCO output frequency divided by N. The PLL acts to make these frequencies equal.

That is, after an initial transient:

$$\frac{f_{OUT}}{N} = \frac{f_{REF}}{R}$$

or

$$f_{OUT} = \frac{N}{R} \times f_{REF}$$

The R values are set by programming the RF1 R-Divider register (Register 6), the RF2 R-Divider register (Register 7) and the IF R-Divider register (Register 8).

The N values are set by programming the RF1 N-Divider register (Register 3), the RF2 N-Divider register (Register 4), and the IF N-Divider register (Register 5).

Each N-Divider is implemented as a conventional high speed divider. That is, it consists of a dual-modulus prescaler, a swallow counter, and a lower speed synchronous counter. However, the control of these sub-circuits is automatically handled. Only the appropriate N value should be programmed.

PLL Loop Dynamics

The transient response for each PLL is determined by its phase detector update rate f_ϕ (equal to f_{REF}/R) and the phase detector gain programmed for each RF1, RF2, or IF synthesizer. See Register 1. Four different settings for the phase detector gain are available for each PLL. The highest gain is programmed by setting the two phase detector gain bits to 00, and the lowest by

setting the bits to 11. The values of the available gains, relative to the highest gain, are as follows:

Table 8. Gain Values (Register 1)

K _p Bits	Relative P.D. Gain
00	1
01	1/2
10	1/4
11	1/8

The gain value bits is automatically set with the Auto K_p bit (bit 2) in the Main Configuration register to 1. In setting this bit, the gain values are optimized for a given value of N. In general, a higher phase detector gain decreases in-band phase noise and increase the speed of the PLL transient until the point at which stability begins to be compromised. The optimal gain depends on N. Table 9 lists recommended settings for different values of N. These are the settings when the Auto K_p bit is set.

Table 9. Optimal K_p Settings

N	RF1 K _{p1} <1:0>	RF2 K _{p2} <3:2>	IF K _{p1} <5:4>
≤2047	00	00	00
2048 to 4095	00	00	01
4096 to 8191	00	01	10
8192 to 16383	01	10	11
16384 to 32767	10	11	11
≥32768	11	11	11

The VCO gain and loop filter characteristics are not programmable.

The settling time for the PLL is directly proportional to its phase detector update period T_ϕ (T_ϕ equals $1/f_\phi$). A typical transient response is shown in Figure 6 on page 11. During the first 13 update periods the Si4133 executes the self-tuning algorithm. From then on the PLL controls the output frequency. Because of the unique architecture of the Si4133 PLLs, the time required to settle the output frequency to 0.1 ppm error is automatically 25 update periods. The total time after powerup or a change in programmed frequency until the synthesized frequency is settled—including time for self-tuning—is approximately 40 update periods.

Note: The settling time analysis holds for RF1 $f_\phi \leq 500$ kHz.

For RF1 $f_\phi > 500$ kHz, the settling time is larger.

RF and IF Outputs

The RFOUT and IFOUT pins are driven by amplifiers that buffer the RF VCOs and IF VCO respectively. The RF output amplifier receives its input from the RF1 or RF2 VCO, depending on which R- or N-Divider register is written last. For example, programming the N-Divider register for RF1 automatically selects the RF1 VCO output.

Figures 13 and 14 show application diagrams for the Si4133. The RF output signal must be ac coupled to its load through a capacitor. An external inductance between the RFOUT pin and the ac coupling capacitor is required as part of an output matching network to maximize power delivered to the load. This 2 nH inductance can be realized with a PC board trace. The network is made to provide an adequate match to an external 50 Ω load for both the RF1 and RF2 frequency bands. The matching network also filters the output signal to reduce harmonic distortion.

The IFOUT pin must also be ac coupled to its load through a capacitor. The IF output level is dependent upon the load. Figure 18 on page 20 displays the output level versus load resistance for a variety of output frequencies. For resistive loads greater than 500 Ω the output level saturates and the bias currents in the IF output amplifier are higher than required. The LPWR bit in the Main Configuration register (Register 0) can be set to 1 to reduce the bias currents and therefore reduce the power dissipated by the IF amplifier. For loads less than 500 Ω , LPWR should be set to 0 to maximize the output level.

For IF frequencies greater than 500 MHz, a matching network is required to drive a 50 Ω load. See Figure 16. The value of L_{MATCH} can be determined from Table 10.

Table 10. L_{MATCH} Values

Frequency	L_{MATCH}
500–600 MHz	40 nH
600–800 MHz	27 nH
800 MHz–1 GHz	18 nH

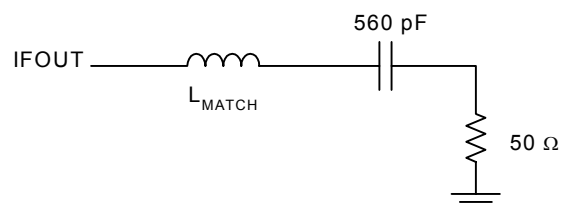

Figure 16. IF Frequencies > 500 MHz

For frequencies less than 500 MHz, the IF output buffer can directly drive a 200 Ω resistive load or higher. For resistive loads greater than 500 Ω ($f < 500$ MHz) the LPWR bit can be set to reduce the power consumed by the IF output buffer. See Figure 17.

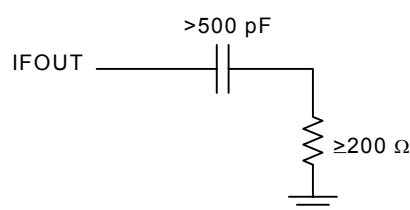

Figure 17. IF Frequencies < 500 MHz

Reference Frequency Amplifier

The Si4133 provides a reference frequency amplifier. If the driving signal has CMOS levels it can be connected directly to the XIN pin. Otherwise, the reference frequency signal should be ac coupled to the XIN pin through a 560 pF capacitor.

Powerdown Modes

Table 11 summarizes the powerdown functionality. The Si4133 can be powered down by taking the \overline{PWDN} pin low or by setting bits in the Powerdown register (Register 2). When the \overline{PWDN} pin is low, the Si4133 is powered down regardless of the Powerdown register settings. When the \overline{PWDN} pin is high, power management is in control of the Powerdown register bits.

The IF and RF sections of the Si4133 circuitry can be individually powered down by setting the Powerdown register bits PDIB and PDRB low, respectively. The reference frequency amplifier is also powered up if the PDRB and PDIB bits are high. Also, setting the AUTOPDB bit to 1 in the Main Configuration register (Register 0) is equivalent to setting both bits in the Powerdown register to 1.

The serial interface remains available and can be written in all powerdown modes.

Auxiliary Output (AUXOUT)

The signal appearing on AUXOUT is selected by setting the AUXSEL bits in the Main Configuration register (Register 0).

The LDET_B signal can be selected by setting the AUXSEL bits to 11. This signal can be used to indicate that the IF or RF PLL is going to lose lock because of excessive ambient temperature drift and should be re-tuned. The LDET_B signal indicates a logical OR result if both IF and RF are simultaneously generating a signal.

Table 11. Powerdown Configuration

$\overline{\text{PWDN}}$ Pin	AUTOPDB	PDIB	PDRB	IF Circuitry	RF Circuitry
$\overline{\text{PWDN}} = 0$	X	X	X	OFF	OFF
$\overline{\text{PWDN}} = 1$	0	0	0	OFF	OFF
	0	0	1	OFF	ON
	0	1	0	ON	OFF
	0	1	1	ON	ON
	1	x	x	ON	ON

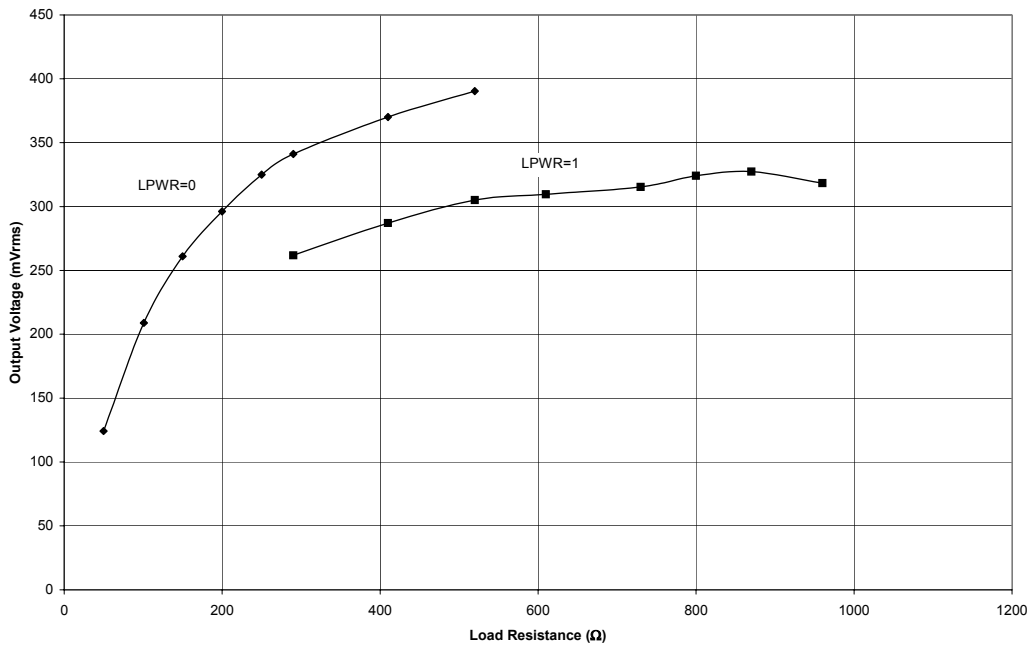

Figure 18. Typical IF Output Voltage vs. Load Resistance at 550 MHz

Control Registers

Table 12. Register Summary

Register	Name	Bit 17	Bit 16	Bit 15	Bit 14	Bit 13	Bit 12	Bit 11	Bit 10	Bit 9	Bit 8	Bit 7	Bit 6	Bit 5	Bit 4	Bit 3	Bit 2	Bit 1	Bit 0
0	Main Configuration	0	0	0	0	AUXSEL [1:0]		IFDIV [1:0]		0	0	0	0	LPWR	0	AUTO PDB	AUTO K _P	RF PWR	0
1	Phase Detector Gain	0	0	0	0	0	0	0	0	0	0	0	0	K _{P1} [1:0]		K _{P2} [1:0]		K _{P1} [1:0]	
2	Powerdown	0	0	0	0	0	0	0	0	0	0	0	0	0	0	0	0	PDIB	PDRB
3	RF1 N-Divider	N _{RF1} [17:0]																	
4	RF2 N-Divider	0	N _{RF2} [16:0]																
5	IF N-Divider	0	0	N _{IF} [15:0]															
6	RF1 R-Divider	0	0	0	0	0	R _{RF1} [12:0]												
7	RF2 R-Divider	0	0	0	0	0	R _{RF2} [12:0]												
8	IF R-Divider	0	0	0	0	0	R _{IF} [12:0]												
9	Reserved																		
.																			
.																			
.																			
15	Reserved																		

Note: Registers 9–15 are reserved. Writes to these registers might result in unpredictable behavior. Registers not listed here are reserved and should not be written.

Register 0. Main Configuration Address Field = A[3:0] = 0000

Bit	D17	D16	D15	D14	D13	D12	D11	D10	D9	D8	D7	D6	D5	D4	D3	D2	D1	D0
Name	0	0	0	0	AUXSEL [1:0]		IFDIV [1:0]		0	0	0	0	LPWR	0	AUTO PDB	AUTO K _p	RF PWR	0

Bit	Name	Function
17:14	Reserved	Program to zero.
13:12	AUXSEL[1:0]	Auxiliary Output Pin Definition. 00 = Reserved. 01 = Force output low. 10 = Reserved. 11 = Lock Detect—LDET _B .
11:10	IFDIV[1:0]	IF Output Divider. 00 = IFOUT = IFVCO Frequency 01 = IFOUT = IFVCO Frequency/2 10 = IFOUT = IFVCO Frequency/4 11 = IFOUT = IFVCO Frequency/8
9:6	Reserved	Program to zero.
5	LPWR	Output Power-Level Settings for IF Synthesizer Circuit. 0 = R _{LOAD} < 500 Ω—normal power mode. 1 = R _{LOAD} ≥ 500 Ω—low power mode.
4	Reserved	Program to zero.
3	AUTOPDB	Auto Powerdown. 0 = Software powerdown is controlled by Register 2. 1 = Equivalent to setting all bits in Register 2 = 1.
2	AUTOK _p	Auto K_p Setting. 0 = K _p s are controlled by Register 1. 1 = K _p s are set according to Table 9 on page 18.
1	RFPWR	Program to zero. (Used for extended frequency operation. See AN41 for more information.)
0	Reserved	Program to zero.

Register 1. Phase Detector Gain Address Field (A[3:0]) = 0001

Bit	D17	D16	D15	D14	D13	D12	D11	D10	D9	D8	D7	D6	D5	D4	D3	D2	D1	D0
Name	0	0	0	0	0	0	0	0	0	0	0	0	K _{P1} [1:0]		K _{P2} [1:0]		K _{P1} [1:0]	

Bit	Name	Function
17:6	Reserved	Program to zero.
5:4	K _{P1} [1:0]	IF Phase Detector Gain Constant.* N Value K _{P1} <2048 = 00 2048–4095 = 01 4096–8191 = 10 >8191 = 11
3:2	K _{P2} [1:0]	RF2 Phase Detector Gain Constant.* N Value K _{P2} <4096 = 00 4096–8191 = 01 8192–16383 = 10 >16383 = 11
1:0	K _{P1} [1:0]	RF1 Phase Detector Gain Constant.* N Value K _{P1} <8192 = 00 8192–16383 = 01 16384–32767 = 10 >32767 = 11

***Note:** When AUTOK_P = 1, these bits do not need to be programmed. When AUTOK_P = 0, use these recommended values for programming Phase Detector Gain.



Register 2. Powerdown Address Field (A[3:0]) = 0010

Bit	D17	D16	D15	D14	D13	D12	D11	D10	D9	D8	D7	D6	D5	D4	D3	D2	D1	D0
Name	0	0	0	0	0	0	0	0	0	0	0	0	0	0	0	0	PDIB	PDRB

Bit	Name	Function
17:2	Reserved	Program to zero.
1	PDIB	Powerdown IF Synthesizer. 0 = IF synthesizer powered down. 1 = IF synthesizer on.
0	PDRB	Powerdown RF Synthesizer. 0 = RF synthesizer powered down. 1 = RF synthesizer on.

Note: Enabling any PLL with PDIB or PDRB automatically powers on the reference amplifier.

Register 3. RF1 N-Divider Address Field (A[3:0]) = 0011

Bit	D17	D16	D15	D14	D13	D12	D11	D10	D9	D8	D7	D6	D5	D4	D3	D2	D1	D0
Name	N _{RF1} [17:0]																	

Bit	Name	Function
17:0	N _{RF1} [17:0]	N-Divider for RF1 Synthesizer.

Register 4. RF2 N-Divider Address Field = A[3:0] = 0100

Bit	D17	D16	D15	D14	D13	D12	D11	D10	D9	D8	D7	D6	D5	D4	D3	D2	D1	D0
Name	0	N _{RF2} [16:0]																

Bit	Name	Function
17	Reserved	Program to zero.
16:0	N _{RF2} [16:0]	N-Divider for RF2 Synthesizer.

Register 5. IF N-Divider Address Field (A[3:0]) = 0101

Bit	D17	D16	D15	D14	D13	D12	D11	D10	D9	D8	D7	D6	D5	D4	D3	D2	D1	D0
Name	0	0	N _{IF} [15:0]															

Bit	Name	Function
17:16	Reserved	Program to zero.
15:0	N _{IF} [15:0]	N-Divider for IF Synthesizer.

Register 6. RF1 R-Divider Address Field (A[3:0]) = 0110

Bit	D17	D16	D15	D14	D13	D12	D11	D10	D9	D8	D7	D6	D5	D4	D3	D2	D1	D0
Name	0	0	0	0	0	R _{RF1} [12:0]												

Bit	Name	Function
17:13	Reserved	Program to zero.
12:0	R _{RF1} [12:0]	R-Divider for RF1 Synthesizer. R _{RF1} can be any value from 7 to 8189 if K _{P1} = 00 8 to 8189 if K _{P1} = 01 10 to 8189 if K _{P1} = 10 14 to 8189 if K _{P1} = 11

Register 7. RF2 R-Divider Address Field (A[3:0]) = 0111

Bit	D17	D16	D15	D14	D13	D12	D11	D10	D9	D8	D7	D6	D5	D4	D3	D2	D1	D0
Name	0	0	0	0	0	R _{RF2} [12:0]												

Bit	Name	Function
17:13	Reserved	Program to zero.
12:0	R _{RF2} [12:0]	R-Divider for RF2 Synthesizer. R _{RF2} can be any value from 7 to 8189 if K _{P2} = 00 8 to 8189 if K _{P2} = 01 10 to 8189 if K _{P2} = 10 14 to 8189 if K _{P2} = 11



Register 8. IF R-Divider Address Field (A[3:0]) = 1000

Bit	D17	D16	D15	D14	D13	D12	D11	D10	D9	D8	D7	D6	D5	D4	D3	D2	D1	D0
Name	0	0	0	0	0	R _{IF} [12:0]												

Bit	Name	Function
17:13	Reserved	Program to zero.
12:0	R _{IF} [12:0]	R-Divider for IF Synthesizer. R _{IF} can be any value from <ul style="list-style-type: none"> 7 to 8189 if K_{P1} = 00 8 to 8189 if K_{P1} = 01 10 to 8189 if K_{P1} = 10 14 to 8189 if K_{P1} = 11

Pin Descriptions: Si4133-BT

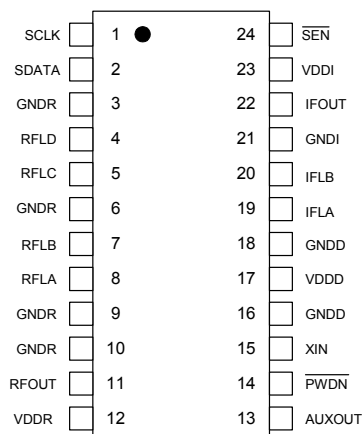

Pin Number	Name	Description
1	SCLK	Serial clock input
2	SDATA	Serial data input
3	GNDR	Common ground for RF analog circuitry
4	RFLD	Pins for inductor connection to RF2 VCO
5	RFLC	Pins for inductor connection to RF2 VCO
6	GNDR	Common ground for RF analog circuitry
7	RFLB	Pins for inductor connection to RF1 VCO
8	RFLA	Pins for inductor connection to RF1 VCO
9	GNDR	Common ground for RF analog circuitry
10	GNDR	Common ground for RF analog circuitry
11	RFOUT	Radio frequency (RF) output of the selected RF VCO
12	VDDR	Supply voltage for the RF analog circuitry
13	AUXOUT	Auxiliary output
14	PWDN	Powerdown input pin
15	XIN	Reference frequency amplifier input
16	GNDD	Common ground for digital circuitry
17	VDDD	Supply voltage for digital circuitry
18	GNDD	Common ground for digital circuitry
19	IFLA	Pins for inductor connection to IF VCO
20	IFLB	Pins for inductor connection to IF VCO
21	GNDI	Common ground for IF analog circuitry
22	IFOUT	Intermediate frequency (IF) output of the IF VCO
23	VDDI	Supply voltage for IF analog circuitry
24	SEN	Enable serial port input



Table 13. Pin Descriptions for Si4133 Derivatives—TSSOP

Pin Number	Si4133	Si4123	Si4122	Si4113	Si4112
1	SCLK	SCLK	SCLK	SCLK	SCLK
2	SDATA	SDATA	SDATA	SDATA	SDATA
3	GNDR	GNDR	GNDR	GNDR	GNDD
4	RFLD	GNDR	RFLD	RFLD	GNDD
5	RFLC	GNDR	RFLC	RFLC	GNDD
6	GNDR	GNDR	GNDR	GNDR	GNDD
7	RFLB	RFLB	GNDR	RFLB	GNDD
8	RFLA	RFLA	GNDR	RFLA	GNDD
9	GNDR	GNDR	GNDR	GNDR	GNDD
10	GNDR	GNDR	GNDR	GNDR	GNDD
11	RFOUT	RFOUT	RFOUT	RFOUT	GNDD
12	VDDR	VDDR	VDDR	VDDR	VDDD
13	AUXOUT	AUXOUT	AUXOUT	AUXOUT	AUXOUT
14	$\overline{\text{PWDN}}$	$\overline{\text{PWDN}}$	$\overline{\text{PWDN}}$	$\overline{\text{PWDN}}$	$\overline{\text{PWDN}}$
15	XIN	XIN	XIN	XIN	XIN
16	GNDD	GNDD	GNDD	GNDD	GNDD
17	VDDD	VDDD	VDDD	VDDD	VDDD
18	GNDD	GNDD	GNDD	GNDD	GNDD
19	IFLA	IFLA	IFLA	GNDD	IFLA
20	IFLB	IFLB	IFLB	GNDD	IFLB
21	GNDI	GNDI	GNDI	GNDD	GNDI
22	IFOUT	IFOUT	IFOUT	GNDD	IFOUT
23	VDDI	VDDI	VDDI	VDDD	VDDI
24	$\overline{\text{SEN}}$	$\overline{\text{SEN}}$	$\overline{\text{SEN}}$	$\overline{\text{SEN}}$	$\overline{\text{SEN}}$

Pin Descriptions: Si4133-BM

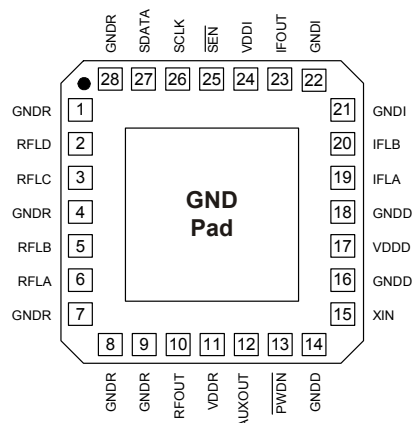

Pin Number	Name	Description
1	GNDR	Common ground for RF analog circuitry
2	RFLD	Pins for inductor connection to RF2 VCO
3	RFLC	Pins for inductor connection to RF2 VCO
4	GNDR	Common ground for RF analog circuitry
5	RFLB	Pins for inductor connection to RF1 VCO
6	RFLA	Pins for inductor connection to RF1 VCO
7	GNDR	Common ground for RF analog circuitry
8	GNDR	Common ground for RF analog circuitry
9	GNDR	Common ground for RF analog circuitry
10	RFOUT	Radio frequency (RF) output of the selected RF VCO
11	VDDR	Supply voltage for the RF analog circuitry
12	AUXOUT	Auxiliary output
13	PW $\overline{\text{DN}}$	Powerdown input pin
14	GNDD	Common ground for digital circuitry
15	XIN	Reference frequency amplifier input
16	GNDD	Common ground for digital circuitry
17	VDDD	Supply voltage for digital circuitry
18	GNDD	Common ground for digital circuitry
19	IFLA	Pins for inductor connection to IF VCO
20	IFLB	Pins for inductor connection to IF VCO
21	GNDI	Common ground for IF analog circuitry
22	GNDI	Common ground for IF analog circuitry
23	IFOUT	Intermediate frequency (IF) output of the IF VCO
24	VDDI	Supply voltage for IF analog circuitry
25	SEN	Enable serial port input
26	SCLK	Serial clock input
27	SDATA	Serial data input
28	GNDR	Common ground for RF analog circuitry



Table 14. Pin Descriptions for Si4133 Derivatives—MLP

Pin Number	Si4133	Si4123	Si4122	Si4113	Si4112
1	GNDR	GNDR	GNDR	GNDR	GNDD
2	RFLD	GNDR	RFLD	RFLD	GNDD
3	RFLC	GNDR	RFLC	RFLC	GNDD
4	GNDR	GNDR	GNDR	GNDR	GNDD
5	RFLB	RFLB	GNDR	RFLB	GNDD
6	RFLA	RFLA	GNDR	RFLA	GNDD
7	GNDR	GNDR	GNDR	GNDR	GNDD
8	GNDR	GNDR	GNDR	GNDR	GNDD
9	GNDR	GNDR	GNDR	GNDR	GNDD
10	RFOUT	RFOUT	RFOUT	RFOUT	GNDD
11	VDDR	VDDR	VDDR	VDDR	VDDD
12	AUXOUT	AUXOUT	AUXOUT	AUXOUT	AUXOUT
13	$\overline{\text{PWN}}$	$\overline{\text{PWN}}$	$\overline{\text{PWN}}$	$\overline{\text{PWN}}$	$\overline{\text{PWN}}$
14	GNDD	GNDD	GNDD	GNDD	GNDD
15	XIN	XIN	XIN	XIN	XIN
16	GNDD	GNDD	GNDD	GNDD	GNDD
17	VDDD	VDDD	VDDD	VDDD	VDDD
18	GNDD	GNDD	GNDD	GNDD	GNDD
19	IFLA	IFLA	IFLA	GNDD	IFLA
20	IFLB	IFLB	IFLB	GNDD	IFLB
21	GNDI	GNDI	GNDI	GNDD	GNDI
22	GNDI	GNDI	GNDI	GNDD	GNDI
23	IFOUT	IFOUT	IFOUT	GNDD	IFOUT
24	VDDI	VDDI	VDDI	VDDD	VDDI
25	$\overline{\text{SEN}}$	$\overline{\text{SEN}}$	$\overline{\text{SEN}}$	$\overline{\text{SEN}}$	$\overline{\text{SEN}}$
26	SCLK	SCLK	SCLK	SCLK	SCLK
27	SDATA	SDATA	SDATA	SDATA	SDATA
28	GNDR	GNDR	GNDR	GNDR	GNDD

Ordering Guide

Ordering Part Number	Description	Operating Temperature
Si4133-BM	RF1/RF2/IF OUT	-40 to 85 °C
Si4133-BT	RF1/RF2/IF OUT	-40 to 85 °C
Si4123-BM	RF1/IF OUT	-40 to 85 °C
Si4123-BT	RF1/IF OUT	-40 to 85 °C
Si4122-BM	RF2/IF OUT	-40 to 85 °C
Si4122-BT	RF2/IF OUT	-40 to 85 °C
Si4113-BM	RF1 OUT	-40 to 85 °C
Si4113-BT	RF1 OUT	-40 to 85 °C
Si4112-BM	IF OUT	-40 to 85 °C
Si4112-BT	IF OUT	-40 to 85 °C

Si4133 Derivative Devices

The Si4133 performs both IF and dual-band RF frequency synthesis. The Si4112, Si4113, Si4122, and the Si4123 are derivatives of this device. Table 15 outlines which synthesizers each derivative device features and the pins and registers that coincide with each synthesizer.

Table 15. Si4133 Derivatives

Name	Synthesizer	Pins	Registers
Si4112	IF	IFLA, IFLB	N_{IF} , R_{IF} , PDIB, IFDIV, LPWR, AUTOPDB = 0, PDRB = 0
Si4113	RF1, RF2	RFLA, RFLB, RFLC, RFLD	N_{RF1} , N_{RF2} , R_{RF1} , R_{RF2} , PDRB, AUTOPDB = 0, PDIB = 0
Si4122	RF2, IF	RFLC, RFLD, IFLA, IFLB	N_{RF2} , R_{RF2} , PDRB, N_{IF} , R_{IF} , PDIB, IFDIV, LPWR
Si4123	RF1, IF	RFLA, RFLB, IFLA, IFLB	N_{RF1} , R_{RF1} , PDRB, N_{IF} , R_{IF} , PDIB, IFDIV, LPWR
Si4133	RF1, RF2, IF	RFLA, RFLB, RFLC, RFLD, IFLA, IFLB	N_{RF1} , N_{RF2} , R_{RF1} , R_{RF2} , PDRB, N_{IF} , R_{IF} , PDIB, IFDIV, LPWR

Package Outline: Si4133-BT

Figure 19 illustrates the package details for the Si4133-BT. Table 16 lists the values for the dimensions shown in the illustration.

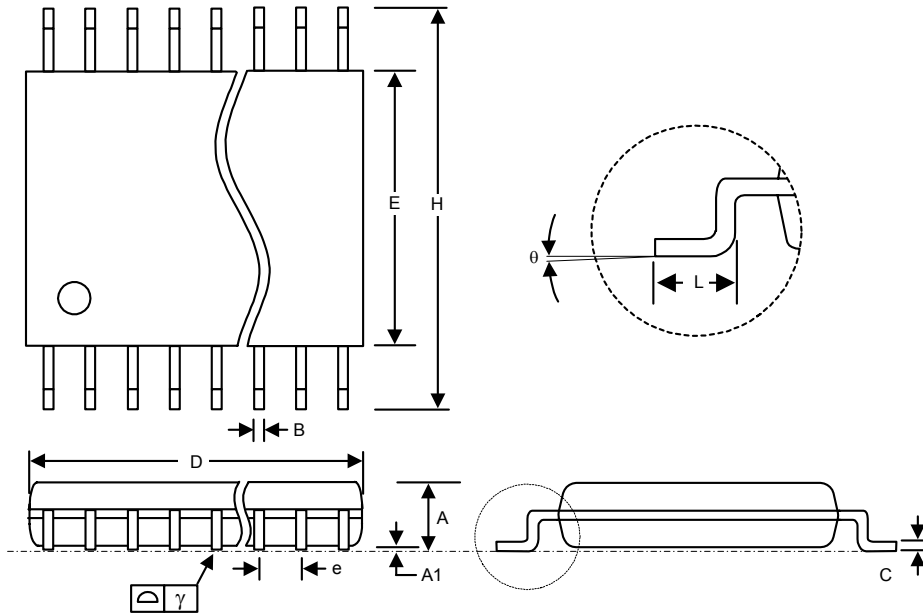

Approximate device weight is 115.7 mg.

Figure 19. 24-Pin Thin Shrink Small Outline Package (TSSOP)

Table 16. Package Diagram Dimensions

Symbol	Millimeters		Typical*
	Min	Max	
A	—	1.20	✓
A1	0.05	0.15	✓
B	0.19	0.30	
C	0.09	0.20	✓
D	7.70	7.90	
E	4.30	4.50	
e	0.65 BSC		
H	6.40 BSC		
L	0.45	0.75	
θ	0°	8°	✓
γ		0.10	
*Note: To guarantee coplanarity (γ), the parameters marked "Typical" may be exceeded.			

Package Outline: Si4133-BM

Figure 20 illustrates the package details for the Si4133-BM. Table 17 lists the values for the dimensions shown in the illustration.

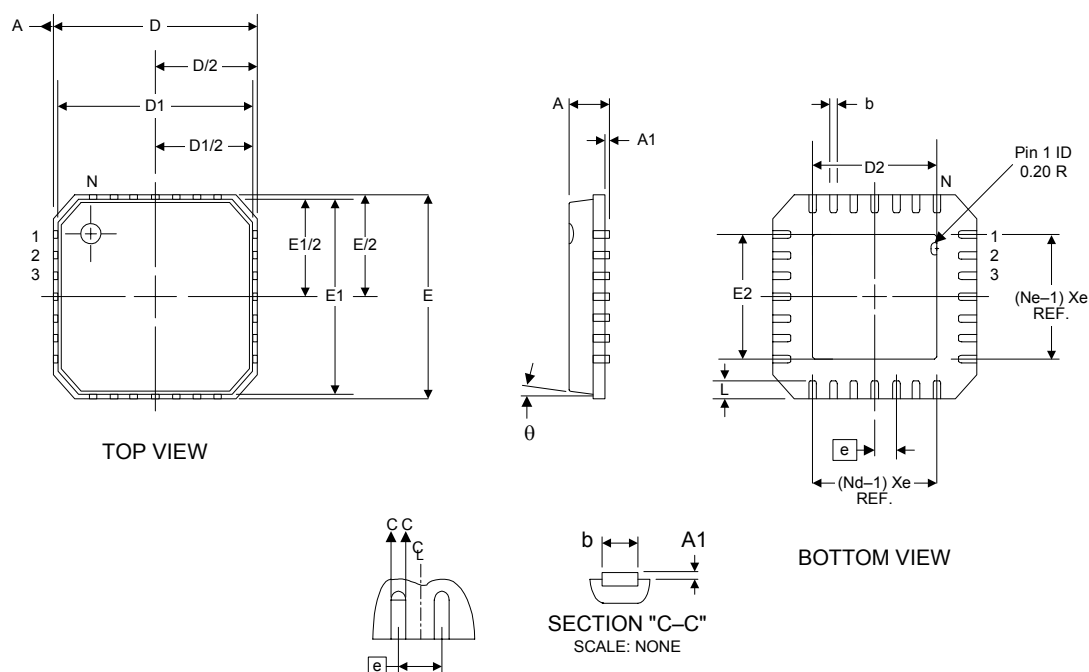

Figure 20. 28-Pin Micro Leadframe Package (MLP)

Table 17. Package Dimensions

Symbol	Millimeters		
	Min	Nom	Max
A	—	0.85	0.90
A1	0.00	0.01	0.05
b	0.18	0.23	0.30
D, E	5.00 BSC		
D1, E1	4.75 BSC		
D2	2.55	2.70	2.85
E2	2.55	2.70	2.85
N	28		
Nd	7		
Ne	7		
e	0.50 BSC		
L	0.50	0.60	0.75
θ			12°

Document Change List

Revision 1.3 to Revision 1.4

- TSSOP outline updated.

Notes:

Contact Information

Silicon Laboratories Inc.

4635 Boston Lane
Austin, Texas 78735
Tel: 1+ (512) 416-8500
Fax: 1+ (512) 416-9669
Toll Free: 1+ (877) 444-3032
Email: productinfo@silabs.com
Internet: www.silabs.com

The information in this document is believed to be accurate in all respects at the time of publication but is subject to change without notice. Silicon Laboratories assumes no responsibility for errors and omissions, and disclaims responsibility for any consequences resulting from the use of information included herein. Additionally, Silicon Laboratories assumes no responsibility for the functioning of undescribed features or parameters. Silicon Laboratories reserves the right to make changes without further notice. Silicon Laboratories makes no warranty, representation or guarantee regarding the suitability of its products for any particular purpose, nor does Silicon Laboratories assume any liability arising out of the application or use of any product or circuit, and specifically disclaims any and all liability, including without limitation consequential or incidental damages. Silicon Laboratories products are not designed, intended, or authorized for use in applications intended to support or sustain life, or for any other application in which the failure of the Silicon Laboratories product could create a situation where personal injury or death may occur. Should Buyer purchase or use Silicon Laboratories products for any such unintended or unauthorized application, Buyer shall indemnify and hold Silicon Laboratories harmless against all claims and damages.

Silicon Laboratories and Silicon Labs are trademarks of Silicon Laboratories Inc.
Other products or brandnames mentioned herein are trademarks or registered trademarks of their respective holders.

Looking for pricing, stock, or lifecycle information?

Click below to explore more details on WIN SOURCE:

 [View SI4133-BT on WIN SOURCE](#)

 [Silicon Labs](#) Information

Optimize Your Supply Chain with WIN SOURCE Solutions

-  Global Sourcing Solution
-  Obsolete Management
-  Cost Control Management
-  Shortage Management
-  Alternative Solution
-  Excess Inventory Management