



**THE DATASHEET OF  
SI5318-G-BC**





## SONET/SDH PRECISION CLOCK MULTIPLIER IC

### Features

- Jitter generation as low as 0.7 ps<sub>RMS</sub> (typ), compliant with GR-253-CORE OC-48 specifications
- No external components (other than a resistor and standard bypassing)
- Input clock ranges at 19, 39, 78, and 155 MHz
- Output clock ranges at 19 or 155 MHz
- Digital hold for loss of input clock
- Selectable loop bandwidth
- Loss-of-signal alarm output
- Low power
- Small size (9x9 mm)

### Applications

- SONET/SDH line/port cards
- Optical modules
- Core switches
- Digital cross connects
- Terabit routers

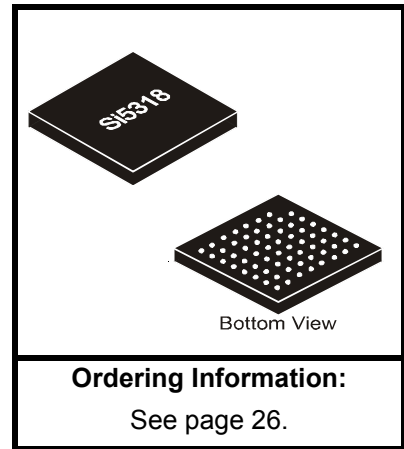

### Description

The Si5318 is a precision clock multiplier designed to exceed the requirements of high-speed communication systems, including OC-48. The device phase locks to an input clock in the 19, 39, 78, or 155 MHz frequency range and generates a low jitter output clock in the 19 or 155 MHz range. Silicon Laboratories' DSPLL® technology delivers all PLL functionality with unparalleled performance while eliminating external loop filter components, providing programmable loop parameters, and simplifying design. The Si5318 establishes a new standard in performance and integration for ultra-low-jitter clock generation. It operates from a single 3.3 V supply.

### Functional Block Diagram

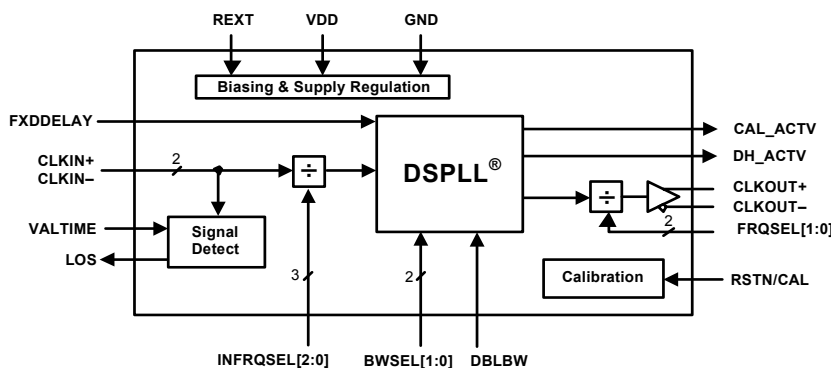

NOTES:

---

**TABLE OF CONTENTS**

---

<b><u>Section</u></b>	<b><u>Page</u></b>
<b>1. Electrical Specifications</b> .....	<b>4</b>
<b>2. Functional Description</b> .....	<b>14</b>
2.1. DSPLL <sup>®</sup> .....	14
2.2. Clock Input and Output Rate Selection .....	14
2.3. PLL Performance .....	15
2.4. Digital Hold of the PLL .....	16
2.5. Hitless Recovery from Digital Hold .....	16
2.6. Loss-of-Signal Alarm .....	16
2.7. Reset .....	17
2.8. PLL Self-Calibration .....	17
2.9. Bias Generation Circuitry .....	17
2.10. Differential Input Circuitry .....	17
2.11. Differential Output Circuitry .....	17
2.12. Power Supply Connections .....	17
2.13. Design and Layout Guidelines .....	19
<b>3. Pin Descriptions: Si5318</b> .....	<b>20</b>
<b>4. Ordering Guide</b> .....	<b>26</b>
<b>5. Package Outline</b> .....	<b>27</b>
<b>6. 9x9 mm CBGA Card Layout</b> .....	<b>28</b>
<b>Document Change List</b> .....	<b>29</b>
<b>Contact Information</b> .....	<b>30</b>



# Si5318

---

## 1. Electrical Specifications

**Table 1. Recommended Operating Conditions**

Parameter	Symbol	Test Condition	Min <sup>1</sup>	Typ	Max <sup>1</sup>	Unit
Ambient Temperature	T <sub>A</sub>		-20 <sup>2</sup>	25	85	°C
Si5318 Supply Voltage <sup>3</sup>	V <sub>DD33</sub>		3.135	3.3	3.465	V

**Notes:**

1. All minimum and maximum specifications are guaranteed and apply across the recommended operating conditions. Typical values apply at nominal supply voltages and an operating temperature of 25 °C unless otherwise stated.
2. The Si5318 is guaranteed by design to operate at -40° C. All electrical specifications are guaranteed for an ambient temperature of -20 to 85° C.
3. The Si5318 specifications are guaranteed when using the recommended application circuit (including component tolerance) of Figure 5 on page 13.

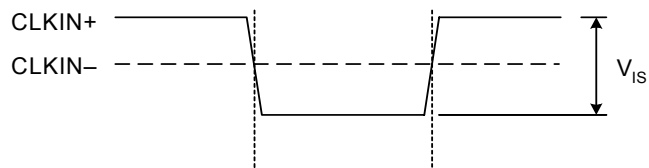

A. Operation with Single-Ended Clock Input

Note: When using single-ended clock sources, the unused clock input on the Si5318 must be ac-coupled to ground.

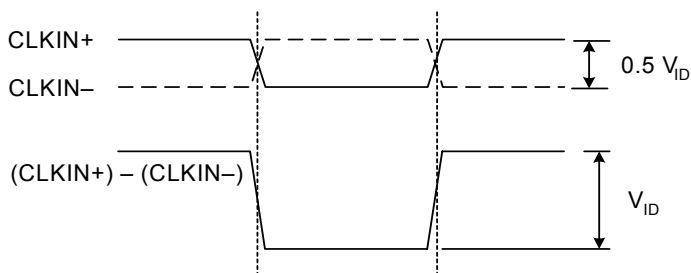

B. Operation with Differential Clock Input

Note: Transmission line termination, when required, must be provided externally

**Figure 1. CLKIN Voltage Characteristics**

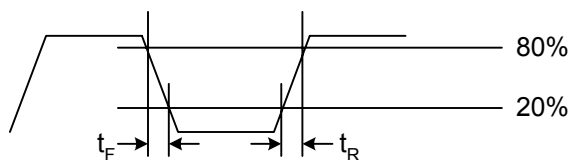

**Figure 2. Rise/Fall Time Measurement**

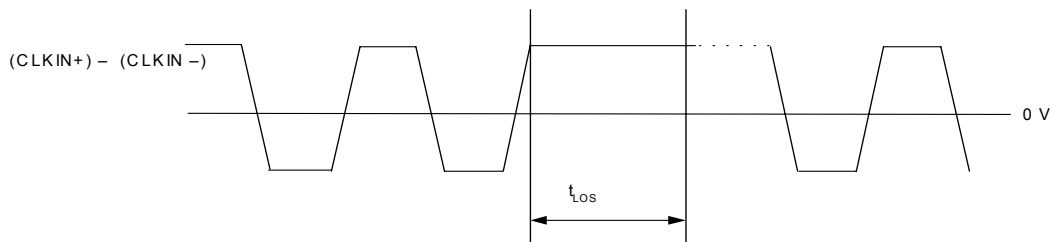

**Figure 3. Transitionless Period on CLKIN for Detecting a LOS Condition**

**Table 2. DC Characteristics,  $V_{DD} = 3.3\text{ V}$**

( $V_{DD33} = 3.3\text{ V} \pm 5\%$ ,  $T_A = -20\text{ to }85\text{ }^\circ\text{C}$ )

Parameter	Symbol	Test Condition	Min	Typ	Max	Unit
Supply Current	$I_{DD}$	Clock in = 19.44 MHz Clock out = 155.52 MHz	—	135	145	mA
Power Dissipation Using 3.3 V Supply	$P_D$	Clock in = 19.44 MHz Clock out = 155.52 MHz	—	445	479	mW
Common Mode Input Voltage <sup>1,2,3</sup> (CLKIN)	$V_{ICM}$		1.0	1.5	2.0	V
Single-Ended Input Voltage <sup>2,3,4</sup> (CLKIN)	$V_{IS}$	See Figure 1A	200	—	500 <sup>4</sup>	mV <sub>PP</sub>
Differential Input Voltage Swing <sup>2,3,4</sup> (CLKIN)	$V_{ID}$	See Figure 1B	200	—	500 <sup>4</sup>	mV <sub>PP</sub>
Input Impedance (CLKIN+, CLKIN-)	$R_{IN}$		—	80	—	k $\Omega$
Differential Output Voltage Swing (CLKOUT)	$V_{OD}$	100 $\Omega$ Load Line-to-Line	720	938	1155	mV <sub>PP</sub>
Output Common Mode Voltage (CLKOUT)	$V_{OCM}$	100 $\Omega$ Load Line-to-Line	1.4	1.8	2.2	V
Output Short to GND (CLKOUT)	$I_{SC(-)}$		-60	—	—	mA
Output Short to $V_{DD25}$ (CLKOUT)	$I_{SC(+)}$		—	15	—	mA
Input Voltage Low (LVTTTL Inputs)	$V_{IL}$		—	—	0.8	V
Input Voltage High (LVTTTL Inputs)	$V_{IH}$		2.0	—	—	V
Input Low Current (LVTTTL Inputs)	$I_{IL}$		—	—	50	$\mu\text{A}$
Input High Current (LVTTTL Inputs)	$I_{IH}$		—	—	50	$\mu\text{A}$
Internal Pulldowns (All LVTTTL Inputs)	$I_{pd}$		—	—	50	$\mu\text{A}$
Input Impedance (LVTTTL Inputs)	$R_{IN}$		50	—	—	k $\Omega$
Output Voltage Low (LVTTTL Outputs)	$V_{OL}$	$I_O = .5\text{ mA}$	—	—	0.4	V
Output Voltage High (LVTTTL Outputs)	$V_{OH}$	$I_O = .5\text{ mA}$	2.0	—	—	V

**Notes:**

1. The Si5318 device provides weak 1.5 V internal biasing that enables ac-coupled operation.
2. Clock inputs may be driven differentially or single-endedly. When driven single-endedly, the unused input should be ac coupled to ground.
3. Transmission line termination, when required, must be provided externally.
4. Although the Si5318 device can operate with input clock swings as high as 1500 mV<sub>PP</sub>, Silicon Laboratories recommends maintaining the input clock amplitude below 500 mV<sub>PP</sub> for optimal performance.

**Table 3. AC Characteristics** $(V_{DD33} = 3.3\text{ V} \pm 5\%, T_A = -20\text{ to }85\text{ }^\circ\text{C})$ 

Parameter	Symbol	Test Condition	Min	Typ	Max	Unit
Input Clock Frequency (CLKIN) INFRQSEL[2:0] = 001 INFRQSEL[2:0] = 010 INFRQSEL[2:0] = 011 INFRQSEL[2:0] = 100	$f_{\text{CLKIN}}$		19.436 38.872 77.744 155.48	— — — —	21.685 43.369 86.738 173.48	MHz
Input Clock Rise Time (CLKIN)	$t_R$	Figure 2	—	—	11	ns
Input Clock Fall Time (CLKIN)	$t_F$	Figure 2	—	—	11	ns
Input Clock Duty Cycle	$C_{\text{DUTY\_IN}}$		40	50	60	%
CLKOUT Frequency Range* FRQSEL[1:0] = 00 (no output) FRQSEL[1:0] = 01 FRQSEL[1:0] = 10	$f_{\text{O}_19}$ $f_{\text{O}_155}$		— 19.436 155.48	— — —	— 21.685 173.48	MHz
CLKOUT Rise Time	$t_R$	Figure 2; single-ended; after 3 cm of 50 $\Omega$ FR4 stripline	—	213	260	ps
CLKOUT Fall Time	$t_F$	Figure 2; single-ended; after 3 cm of 50 $\Omega$ FR4 stripline	—	191	260	ps
CLKOUT Duty Cycle	$C_{\text{DUTY\_OUT}}$	Differential: (CLKOUT+) – (CLKOUT–)	48	—	52	%
RSTN/CAL Pulse Width	$t_{\text{RSTN}}$		20	—	—	ns
Transitionless Period Required on CLKIN for Detecting a LOS Condition. INFRQSEL[2:0] = 001 INFRQSEL[2:0] = 010 INFRQSEL[2:0] = 011 INFRQSEL[2:0] = 100 INFRQSEL[2:0] = 101 INFRQSEL[2:0] = 110	$t_{\text{LOS}}$	Figure 3	$\frac{6}{f_{\text{O}_155}}$ $\frac{4}{f_{\text{O}_155}}$ $\frac{3}{f_{\text{O}_155}}$ $\frac{5}{2} \times f_{\text{O}_155}$ $\frac{9}{4} \times f_{\text{O}_155}$ $\frac{9}{4} \times f_{\text{O}_155}$	— — — — — —	$\frac{8}{f_{\text{O}_155}}$ $\frac{8}{f_{\text{O}_155}}$ $\frac{8}{f_{\text{O}_155}}$ $\frac{8}{f_{\text{O}_155}}$ $\frac{8}{f_{\text{O}_155}}$ $\frac{8}{f_{\text{O}_155}}$	s
Recovery Time for Clearing an LOS Condition VALTIME = 0 VALTIME = 1	$t_{\text{VAL}}$	Measured from when a valid reference clock is applied until the LOS flag clears	0.09 12.0	— —	0.22 14.1	s

**\*Note:** The Si5318 provides a 1/8, 1/4, 1/2, 1, 2, 4 or 8x clock frequency multiplication function.

**Table 4. AC Characteristics (PLL Performance Characteristics)** $(V_{DD33} = 3.3\text{ V} \pm 5\%, TA = -20\text{ to } 85\text{ }^{\circ}\text{C})$ 

Parameter	Symbol	Test Condition	Min	Typ	Max	Unit
<b>Wander/Jitter at 800 Hz Bandwidth (BWSEL[1:0] = 10 and DBLBW = 0)</b>						
Jitter Tolerance (see Figure 7)	$J_{TOL(PP)}$	f = 8 Hz	1000	—	—	ns
		f = 80 Hz	100	—	—	ns
		f = 800 Hz	10	—	—	ns
CLKOUT RMS Jitter Generation	$J_{GEN(RMS)}$	12 kHz to 20 MHz	—	0.87	1.2	ps
CLKOUT Peak-Peak Jitter Generation	$J_{GEN(PP)}$	12 kHz to 20 MHz	—	7.3	10.0	ps
Jitter Transfer Bandwidth (see Figure 6)	$F_{BW}$	BW = 800 Hz	—	800	—	Hz
Wander/Jitter Transfer Peaking	$J_P$	< 800 Hz	—	0.0	0.05	dB
<b>Wander/Jitter at 1600 Hz Bandwidth (BWSEL[1:0] = 10 and DBLBW = 1)</b>						
Jitter Tolerance (see Figure 7)		f = 16 Hz	500	—	—	ns
		f = 160 Hz	50	—	—	ns
		f = 1600 Hz	5	—	—	ns
CLKOUT RMS Jitter Generation	$J_{GEN(RMS)}$	12 kHz to 20 MHz	—	0.78	1.2	ps
CLKOUT Peak-Peak Jitter Generation	$J_{GEN(PP)}$	12 kHz to 20 MHz	—	7.0	9.0	ps
Jitter Transfer Bandwidth (see Figure 6)	$F_{BW}$	BW = 1600 Hz	—	1600	—	Hz
Wander/Jitter Transfer Peaking	$J_P$	< 1600 Hz	—	0.00	0.05	dB
<b>Wander/Jitter at 1600 Hz Bandwidth (BWSEL[1:0] = 01 and DBLBW = 0)</b>						
Jitter Tolerance (see Figure 7)	$J_{TOL(PP)}$	f = 16 Hz	1000	—	—	ns
		f = 160 Hz	100	—	—	ns
		f = 1600 Hz	10	—	—	ns
CLKOUT RMS Jitter Generation	$J_{GEN(RMS)}$	12 kHz to 20 MHz	—	0.82	1.0	ps
CLKOUT Peak-Peak Jitter Generation	$J_{GEN(PP)}$	12 kHz to 20 MHz	—	7.3	10.0	ps
Jitter Transfer Bandwidth (see Figure 10)	$F_{BW}$	BW = 1600 Hz	—	1600	—	Hz
Wander/Jitter Transfer Peaking	$J_P$	< 1600 Hz	—	0.0	0.1	dB
<b>Notes:</b>						
<ol style="list-style-type: none"> <li>Higher PLL bandwidth settings provide smaller clock output wander with temperature gradient.</li> <li>For reliable device operation, temperature gradients should be limited to 10 °C/min.</li> <li>Telcordia GR-1244-CORE requirements specify maximum phase transient slope during clock rearrangement in terms of nanoseconds per millisecond. The equivalent ps/μs unit is used here since the maximum phase transient magnitude for the Si5318 (tPT_MTIIE) never reaches one nanosecond.</li> </ol>						

**Table 4. AC Characteristics (PLL Performance Characteristics) (Continued)** $(V_{DD33} = 3.3 \text{ V} \pm 5\%, T_A = -20 \text{ to } 85 \text{ }^\circ\text{C})$ 

Parameter	Symbol	Test Condition	Min	Typ	Max	Unit
<b>Wander/Jitter at 3200 Hz Bandwidth (BWSEL[1:0] = 01 and DBLBW = 1)</b>						
Jitter Tolerance (see Figure 7)		f = 32 Hz	500	—	—	ns
		f = 320 Hz	50	—	—	ns
		f = 3200 Hz	5	—	—	ns
CLKOUT RMS Jitter Generation	$J_{GEN(RMS)}$	12 kHz to 20 MHz	—	0.72	0.9	ps
CLKOUT Peak-Peak Jitter Generation	$J_{GEN(PP)}$	12 kHz to 20 MHz	—	6.8	10.0	ps
Jitter Transfer Bandwidth (see Figure 6)	$F_{BW}$	BW = 3200 Hz	—	3200	—	Hz
Wander/Jitter Transfer Peaking	$J_P$	< 3200 Hz	—	0.05	0.1	dB
<b>Wander/Jitter at 3200 Hz Bandwidth (BWSEL[1:0] = 00 and DBLBW = 0)</b>						
Jitter Tolerance (see Figure 7)	$J_{TOL(PP)}$	f = 32 Hz	1000	—	—	ns
		f = 320 Hz	100	—	—	ns
		f = 3200 Hz	10	—	—	ns
CLKOUT RMS Jitter Generation	$J_{GEN(RMS)}$	12 kHz to 20 MHz	—	0.86	1.2	ps
CLKOUT Peak-Peak Jitter Generation	$J_{GEN(PP)}$	12 kHz to 20 MHz	—	7.7	10.0	ps
Jitter Transfer Bandwidth (see Figure 6)	$F_{BW}$	BW = 3200 Hz	—	3200	—	Hz
Wander/Jitter Transfer Peaking	$J_P$	< 3200 Hz	—	0.05	0.1	dB
<b>Wander/Jitter at 6400 Hz Bandwidth (BWSEL[1:0] = 00 and DBLBW = 1)</b>						
Jitter Tolerance (see Figure 7)		f = 64 Hz	500	—	—	ns
		f = 640 Hz	50	—	—	ns
		f = 6400 Hz	5	—	—	ns
CLKOUT RMS Jitter Generation	$J_{GEN(RMS)}$	12 kHz to 20 MHz	—	0.7	1.0	ps
CLKOUT Peak-Peak Jitter Generation	$J_{GEN(PP)}$	12 kHz to 20 MHz	—	6.6	9.0	ps
Jitter Transfer Bandwidth (see Figure 6)	$F_{BW}$	BW = 6400 Hz	—	6400	—	Hz
Wander/Jitter Transfer Peaking	$J_P$	< 6400 Hz	—	0.05	0.1	dB
<b>Notes:</b>						
1. Higher PLL bandwidth settings provide smaller clock output wander with temperature gradient.						
2. For reliable device operation, temperature gradients should be limited to 10 °C/min.						
3. Telcordia GR-1244-CORE requirements specify maximum phase transient slope during clock rearrangement in terms of nanoseconds per millisecond. The equivalent ps/μs unit is used here since the maximum phase transient magnitude for the Si5318 (tPT_MTIIE) never reaches one nanosecond.						

**Table 4. AC Characteristics (PLL Performance Characteristics) (Continued)** $(V_{DD33} = 3.3\text{ V} \pm 5\%, TA = -20\text{ to }85\text{ }^{\circ}\text{C})$ 

Parameter	Symbol	Test Condition	Min	Typ	Max	Unit
<b>Wander/Jitter at 6400 Hz Bandwidth (BWSEL[1:0] = 11 and DBLBW = 0)</b>						
Jitter Tolerance (see Figure 7)	$J_{TOL(PP)}$	f = 64 Hz	1000	—	—	ns
		f = 640 Hz	100	—	—	ns
		f = 6400 Hz	10	—	—	ns
CLKOUT RMS Jitter Generation	$J_{GEN(RMS)}$	12 kHz to 20 MHz	—	1.0	1.4	ps
CLKOUT Peak-Peak Jitter Generation	$J_{GEN(PP)}$	12 kHz to 20 MHz	—	9.4	12.0	ps
Jitter Transfer Bandwidth (see Figure 6)	$F_{BW}$	BW = 6400 Hz	—	6400	—	Hz
Wander/Jitter Transfer Peaking	$J_P$	< 6400 Hz	—	0.05	0.1	dB
<b>Wander/Jitter at 12800 Hz Bandwidth (BWSEL[1:0] = 11 and DBLBW = 1)</b>						
Jitter Tolerance (see Figure 7)		f = 128 Hz	500	—	—	ns
		f = 1280 Hz	50	—	—	ns
		f = 12800 Hz	5	—	—	ns
CLKOUT RMS Jitter Generation	$J_{GEN(RMS)}$	12 kHz to 20 MHz	—	0.74	1.0	ps
CLKOUT Peak-Peak Jitter Generation	$J_{GEN(PP)}$	12 kHz to 20 MHz	—	6.9	9.0	ps
Jitter Transfer Bandwidth (see Figure 6)	$F_{BW}$	BW = 12800 Hz	—	12800	—	Hz
Wander/Jitter Transfer Peaking	$J_P$	< 12800 Hz	—	0.05	0.1	dB
Acquisition Time	$T_{AQ}$	RSTN/CAL high to CAL_ACTV low, with valid clock input and VALTIME = 0	—	300	350	ms
Clock Output Wander with Temperature Gradient <sup>1,2</sup>	$C_{CO\_TG}$	Stable Input Clock; Temperature Gradient <10 °C/min; 800 Hz Loop BW	—	—	50	ps/ °C/ min
<b>Notes:</b>						
1. Higher PLL bandwidth settings provide smaller clock output wander with temperature gradient.						
2. For reliable device operation, temperature gradients should be limited to 10 °C/min.						
3. Telcordia GR-1244-CORE requirements specify maximum phase transient slope during clock rearrangement in terms of nanoseconds per millisecond. The equivalent ps/μs unit is used here since the maximum phase transient magnitude for the Si5318 (tPT_MTIIE) never reaches one nanosecond.						

**Table 4. AC Characteristics (PLL Performance Characteristics) (Continued)** $(V_{DD33} = 3.3 \text{ V} \pm 5\%, T_A = -20 \text{ to } 85 \text{ }^\circ\text{C})$ 

Parameter	Symbol	Test Condition	Min	Typ	Max	Unit
Initial Frequency Accuracy in Digital Hold Mode (first 100 ms with supply voltage and temperature held constant)	$C_{DH\_FA}$	Stable Input Clock Selected until entering Digital Hold	—	—	10	ppm
Clock Output Frequency Accuracy Over Temperature in Digital Hold Mode	$C_{DH\_T}$	Constant Supply Voltage	—	16.7	30	ppm/ $^\circ\text{C}$
Clock Output Frequency Accuracy Over Supply Voltage in Digital Hold Mode	$C_{DH\_V33}$	Constant Temperature	—	—	250	ppm/V
Clock Output Phase Step <sup>3</sup> (See Figure 8)	$t_{PT\_MTIE}$	When hitlessly recovering from Digital Hold mode	-200	0	200	ps
Clock Output Phase Step Slope <sup>3</sup> (See Figure 8)	$m_{PT}$	When hitlessly recovering from Digital Hold mode				
BWSEL[1:0] = 11, DBLBW = 0		6400 Hz	—	—	10	ps/ $\mu\text{s}$
BWSEL[1:0] = 00, DBLBW = 0		3200 Hz	—	—	5	
BWSEL[1:0] = 01, DBLBW = 0		1600 Hz	—	—	2.5	
BWSEL[1:0] = 10, DBLBW = 0		800 Hz	—	—	1.25	

**Notes:**

- Higher PLL bandwidth settings provide smaller clock output wander with temperature gradient.
- For reliable device operation, temperature gradients should be limited to 10  $^\circ\text{C}/\text{min}$ .
- Telcordia GR-1244-CORE requirements specify maximum phase transient slope during clock rearrangement in terms of nanoseconds per millisecond. The equivalent ps/ $\mu\text{s}$  unit is used here since the maximum phase transient magnitude for the Si5318 ( $t_{PT\_MTIE}$ ) never reaches one nanosecond.

**Table 5. Absolute Maximum Ratings**

Parameter	Symbol	Value	Unit
3.3 V DC Supply Voltage	$V_{DD33}$	-0.5 to 3.6	V
LVTTL Input Voltage	$V_{DIG}$	-0.3 to ( $V_{DD33} + 0.3$ )	V
Maximum Current any output PIN		$\pm 50$	mA
Operating Junction Temperature	$T_{JCT}$	-55 to 150	$^{\circ}C$
Storage Temperature Range	$T_{STG}$	-55 to 150	$^{\circ}C$
ESD HBM Tolerance (100 pf, 1.5 k $\Omega$ )		1.0	kV

**Note:** Permanent device damage may occur if the above Absolute Maximum Ratings are exceeded. Functional operation should be restricted to the conditions as specified in the operational sections of this data sheet. Exposure to absolute maximum rating conditions for extended periods may affect device reliability.

**Table 6. Thermal Characteristics**

Parameter	Symbol	Test Condition	Value	Unit
Thermal Resistance Junction to Ambient	$\theta_{JA}$	Still Air	20	$^{\circ}C/W$

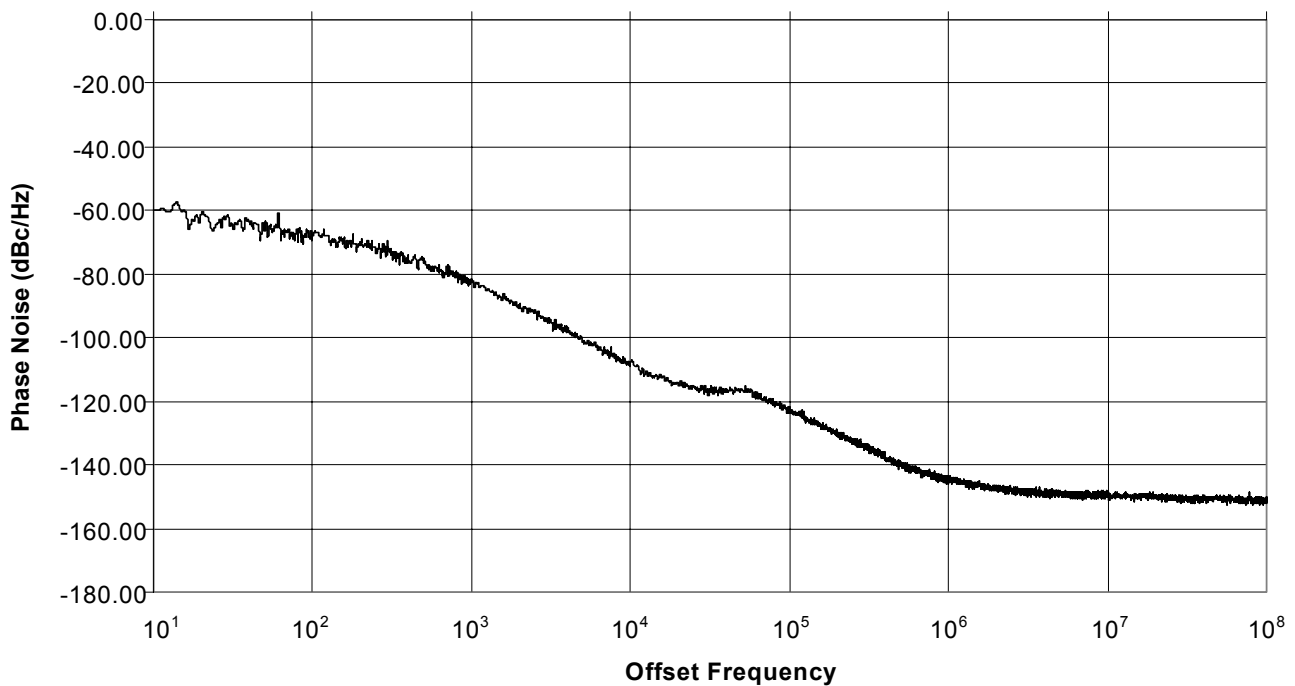

**Figure 4. Typical Si5318 Phase Noise (CLKIN = 155.52 MHz, CLKOUT = 155.52 MHz, and Loop BW = 800 Hz)**

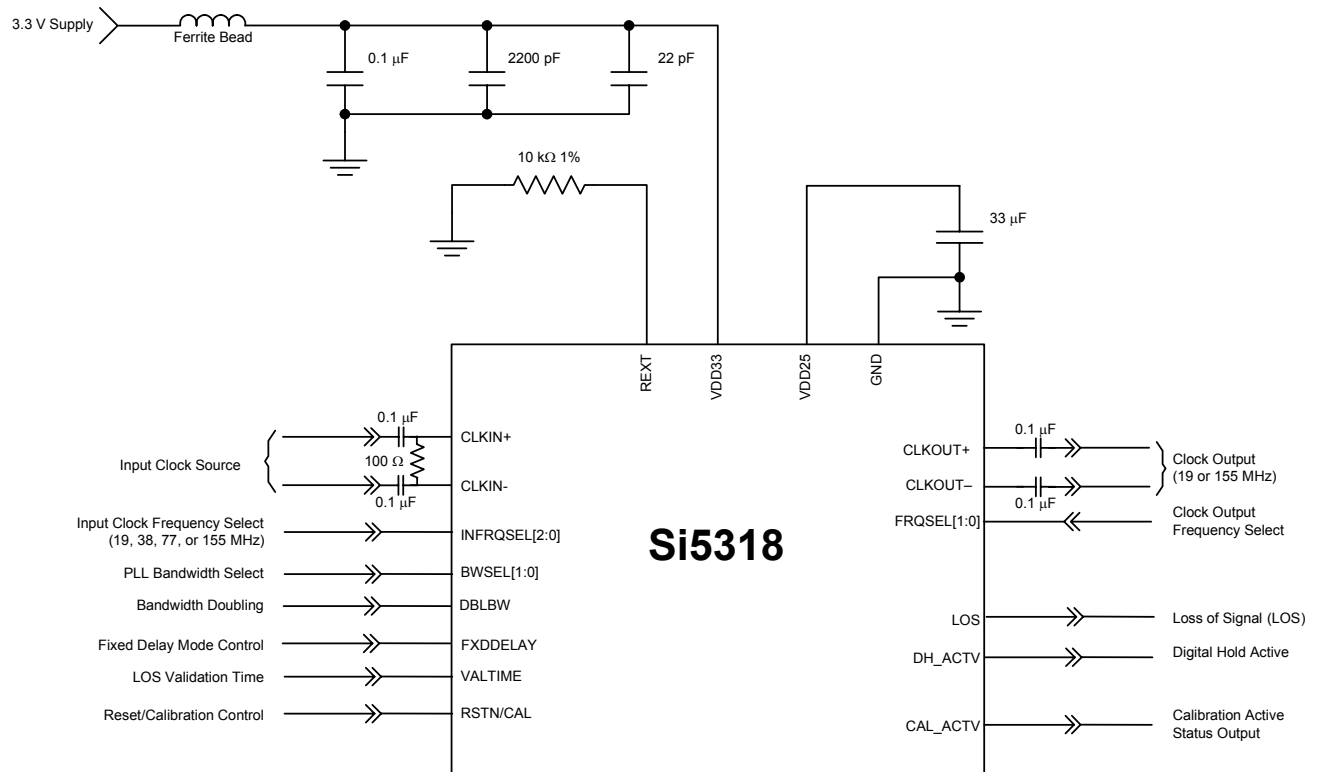

**Figure 5. Si5318 Typical Application Circuit (3.3 V Supply)**

## 2. Functional Description

The Si5318 is a high-performance precision clock multiplication and clock generation device. This device accepts a clock input in the 19, 39, 78, or 155 MHz range, attenuates significant amounts of jitter, and generates a clock output in the 19 or 155 MHz range.

The Si5318 employs Silicon Laboratories DSPLL<sup>®</sup> technology to provide excellent jitter performance while minimizing the external component count and maximizing flexibility and ease-of-use. The Si5318 DSPLL phase locks to the input clock signal, attenuates jitter, and multiplies the clock frequency to generate the device SONET/SDH-compliant clock output. The DSPLL loop bandwidth is user-selectable, allowing the Si5318 jitter performance to be optimized for different applications. The Si5318 can produce a clock output with jitter generation as low as 1.0 pSRMS (see Table 4), making the device an ideal solution for clock multiplication in SONET/SDH systems.

The Si5318 monitors the clock input signal for loss-of-signal, and provides a loss-of-signal (LOS) alarm when missing pulses are detected. The Si5318 provides a digital hold capability to continue generation of a stable output clock when the input reference is lost.

### 2.1. DSPLL<sup>®</sup>

The Si5318 phase-locked loop (PLL) uses Silicon Laboratories' DSPLL technology to eliminate jitter, noise, and the need for external loop filter components found in traditional PLL implementations. This is achieved by using a digital signal processing (DSP) algorithm to replace the loop filter commonly found in analog PLL designs. This algorithm processes the phase detector error term and generates a digital control value to adjust the frequency of the voltage-controlled oscillator (VCO). The technology produces a low phase noise clock with less jitter than is generated using traditional methods. See Figure 4 for an example phase noise plot. In addition, because external loop filter components are not required, sensitive noise entry points are eliminated, making the DSPLL less susceptible to board-level noise sources.

This digital technology also allows for highly stable and consistent operation over all process, temperature, and voltage variations.

#### 2.1.1. Selectable Loop Filter Bandwidth

The digital nature of the DSPLL loop filter allows control of the loop filter parameters without the need to change external components. The Si5318 provides the user with up to eight user-selectable loop bandwidth settings for different system requirements. The base loop bandwidth is selected using the BWSEL [1:0] and DBLBW = 0 pins. When DBLBW is driven high, the bandwidth selected on the BWSEL[1:0] pins is doubled. (See Table 7.)

When DBLBW is asserted, the Si5318 shows improved jitter generation performance. DBLBW function is defined only when hitless recovery from digital hold is disabled. Therefore, when DBLBW is high, the user must also drive FXDDELAY high for proper operation.

### 2.2. Clock Input and Output Rate Selection

The Si5318 provides a 1/8x, 1/4x, 1/2x, 1x, 2x, 4x, or 8x clock frequency multiplication function. Output rates vary in accordance with the input clock rate. The multiplication factor is configured by selecting the input and output clock frequency ranges for the device.

The Si5318 accepts an input clock in the 19, 39, 78, or 155 MHz frequency range. The input frequency range is selected using the INFRQSEL[2:0] pins. The INFRQSEL[2:0] settings and associated output clock rates are given in Table 8.

The Si5318 DSPLL phase locks to the clock input signal to generate an internal VCO frequency that is a multiple of the input clock frequency. The internal VCO frequency is divided down to produce a clock output in the 19 or 155 MHz frequency range. The clock output range is selected using the Frequency Select (FRQSEL[1:0]) pins. The FRQSEL[1:0] settings and associated output clock rates are given in Table 9.

The Si5318 clock input frequencies are variable within the range specified in Table 3 on page 7. The output rates scale accordingly. When a 19.44 MHz input clock is used, the clock output frequency is 19.44 or 155.52 MHz.

Table 7. Loop Bandwidth Settings

Loop Bandwidth	BWSEL1	BWSEL0	DBLBW*
12800 Hz	1	1	1
6400 Hz	1	1	0
6400 Hz	0	0	1
3200 Hz	0	0	0
3200 Hz	0	1	1
1600 Hz	0	1	0
1600 Hz	1	0	1
800 Hz	1	0	0

\*Note: When DBLBW = 1, FXDDELAY must be asserted.

Table 8. Nominal Clock Input Frequencies

Input Clock Frequency Range	INFRQSEL2	INFRQSEL1	INFRQSEL0
Reserved	1	1	1
Reserved	1	1	0
Reserved	1	0	1
155 MHz	1	0	0
78 MHz	0	1	1
39 MHz	0	1	0
19 MHz	0	0	1
Reserved	0	0	0

Table 9. Nominal Clock Output Frequencies

Output Clock Frequency Range	FRQSEL1	FRQSEL0
Reserved	1	1
155 MHz	1	0
19 MHz	0	1
Driver Powerdown	0	0

## 2.3. PLL Performance

The Si5318 PLL is designed to provide extremely low jitter generation, high jitter tolerance, and a well-controlled jitter transfer function with low peaking and a high degree of jitter attenuation.

### 2.3.1. Jitter Generation

Jitter generation is defined as the amount of jitter produced at the output of the device with a jitter free input clock. Generated jitter arises from sources within the VCO and other PLL components. Jitter generation is also a function of the PLL bandwidth setting. Higher loop bandwidth settings may result in lower jitter generation, but may also result in less attenuation of jitter on the input clock signal.

### 2.3.2. Jitter Transfer

Jitter transfer is defined as the ratio of output signal jitter to input signal jitter for a specified jitter frequency. The jitter transfer characteristic determines the amount of input clock jitter that passes to the outputs. The DSPLL technology used in the Si5318 provides tightly-controlled jitter transfer curves because the PLL gain parameters are determined by digital circuits that do not vary over supply voltage, process, and temperature. In a system application, a well-controlled transfer curve minimizes the output clock jitter variation from board to board, providing more consistent system level jitter performance.

The jitter transfer characteristic is a function of the BWSEL[1:0] setting. (See Table 7.) Lower bandwidth selection settings result in more jitter attenuation of the incoming clock but may result in higher jitter generation. Table 4 on page 8 gives the 3 dB bandwidth and peaking values for specified BWSEL settings. Figure 6 shows the jitter transfer curve mask.

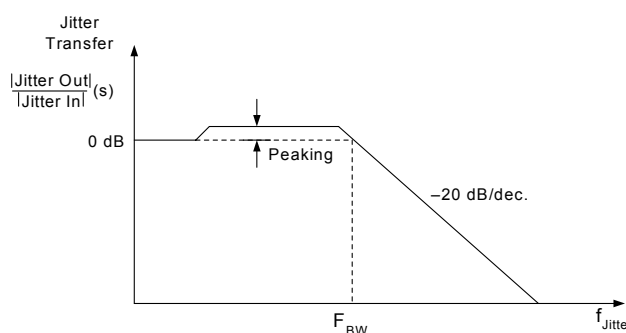

Figure 6. PLL Jitter Transfer Mask/Template

### 2.3.3. Jitter Tolerance

Jitter tolerance for the Si5318 is defined as the maximum peak-to-peak sinusoidal jitter that can be present on the incoming clock. The tolerance is a function of the jitter frequency, because tolerance improves for lower input jitter frequency. See Figure 7.

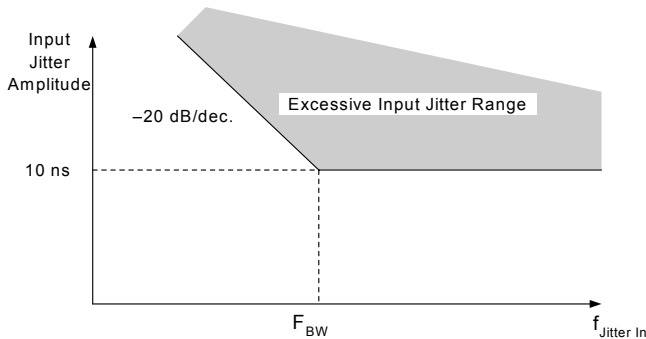

Figure 7. Jitter Tolerance Mask/Template

### 2.4. Digital Hold of the PLL

When no valid input clock is available, the Si5318 digitally holds the internal oscillator to its last frequency value. This provides a stable clock to the system until an input clock is again valid. This clock maintains very stable operation in the presence of constant voltage and temperature. The frequency accuracy specifications for digital hold mode are given in Table 4 on page 8.

### 2.5. Hitless Recovery from Digital Hold

When the Si5318 device is locked to a valid input clock, a loss of the input clock causes the device to automatically switch to digital hold mode. When the input clock signal returns, the device performs a “hitless” transition from digital hold mode back to the selected input clock. That is, the device performs “phase build-out” to absorb the phase difference between the internal VCO clock operating in digital hold mode and the new/returned input clock. The maximum phase step size seen at the clock output during this transition and the maximum slope for this phase step are given in Table 4 on page 8.

This feature can be disabled by asserting the FXDDELAY pin. When the FXDDELAY pin is high, the output clock is phase and frequency locked with a known phase relationship to the input clock. Consequently, any abrupt phase change on the input clock propagates through the device, and the output clock slews at the selected loop bandwidth until the original phase relationship is restored.

**Note:** When the DBLBW is asserted, hitless recovery must also be disabled by driving FXDDELAY high for proper operation.

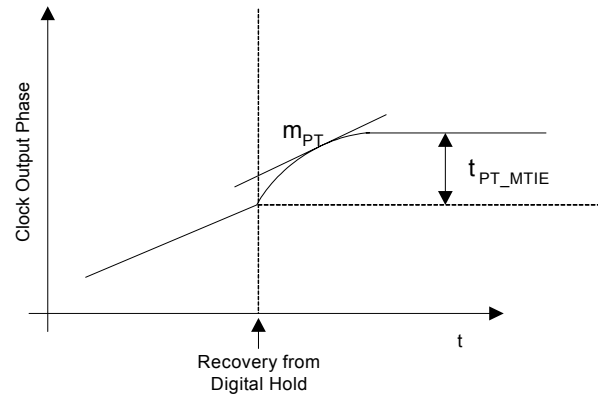

Figure 8. Recovery from Digital Hold

### 2.6. Loss-of-Signal Alarm

The Si5318 has loss-of-signal (LOS) circuitry that constantly monitors the CLKIN input clock for missing pulses. The LOS circuitry sets a LOS output alarm signal when missing pulses are detected.

The LOS circuitry operates as follows. Regardless of the selected input clock frequency range, the LOS circuitry divides down the input clock into the 19 MHz range. The LOS circuitry then over-samples this divided-down input clock to search for extended periods of time without input clock transitions. If the LOS circuitry detects four consecutive samples of the divided-down input clock that are the same state (i.e., 1111 or 0000), a LOS condition is declared, the Si5318 goes into digital hold mode, and the LOS output alarm signal is set high. The LOS sampling circuitry runs at a frequency of  $f_{O\_155/2}$ , where  $f_{O\_155}$  is the output clock frequency when the FRQSEL[1:0] pins are set to 10. Table 3 on page 7 lists the minimum and maximum transitionless time periods required for declaring a LOS on the input clock ( $t_{LOS}$ ).

Once the LOS alarm is asserted, it is held high until the input clock is validated over a time period designated by the VALTIME pin. When VALTIME is low, the validation time period is about 100 ms. When VALTIME is high, the validation time period is about 13 s. If another LOS condition is detected on the input clock during the validation time (i.e., if another set of 1111 or 0000 samples are detected), the LOS alarm remains asserted, and the validation time starts over. When the LOS alarm is finally released, the Si5318 exits digital hold mode and locks to the input clock. The LOS alarm is automatically set high at power-on and at every low-to-high transition of the RSTN/CAL pin. In these cases, the Si5318 undergoes a self-calibration before releasing the LOS alarm and locking to the input clock.

The Si5318 also provides an output indicating the digital hold status of the device, DH\_ACTV. The Si5318 only enters the digital hold mode upon the loss of the input clock. When this occurs, the LOS alarm will also be active. Therefore, applications that require monitoring of the status of the Si5318 need only monitor the CAL\_ACTV and either the LOS or DH\_ACTV outputs to know the state of the device.

## 2.7. Reset

The Si5318 provides a Reset/Calibration pin, RSTN/CAL, which resets the device and disables the outputs. When the RSTN/CAL pin is driven low, the internal circuitry enters into the reset mode, and all LVTTTL outputs are forced into a high-impedance state. Also, the CLKOUT+ and CLKOUT- pins are forced to a nominal CML logic LOW and HIGH respectively (See Figure 9). This feature is useful in in-circuit test applications. A low-to-high transition on RSTN/CAL initializes all digital logic to a known condition and initiates self-calibration of the DSPLL. Upon completion of self-calibration, the DSPLL begins to lock to the clock input signal.

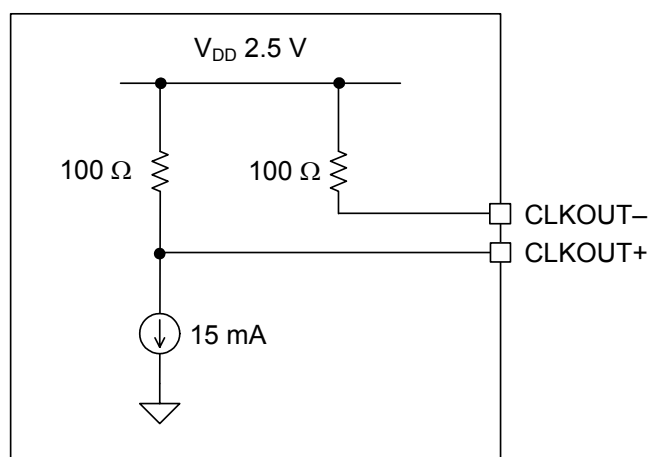

**Figure 9. CLKOUT± Equivalent Circuit, RSTN/CAL asserted LOW**

## 2.8. PLL Self-Calibration

The Si5318 achieves optimal jitter performance by using self-calibration circuitry to set the VCO center frequency and loop gain parameters within the DSPLL. Internal circuitry generates self calibration automatically on powerup or after a loss of power condition. Self-calibration can also be manually initiated by a low-to-high transition on the RSTN/CAL input.

Whether manually initiated or automatically initiated at powerup, the self-calibration process requires the presence of a valid input clock.

If the self-calibration is initiated without a valid clock present, the device waits for a valid clock before completing the self-calibration. The Si5318 clock output is set to the lower end of the operating frequency range while the device is waiting for a valid clock. After the clock input is validated, the calibration process runs to completion; the device locks to the clock input, and the clock output shifts to its target frequency. Subsequent losses of the input clock signal do not require re-calibration. If the clock input is lost following self-calibration, the device enters digital hold mode. When the input clock returns, the device re-locks to the input clock without performing a self-calibration. During the calibration process, the output clock frequency is indeterminate and may jump as high as 5% above the final locked value.

## 2.9. Bias Generation Circuitry

The Si5318 makes use of an external resistor to set internal bias currents. The external resistor allows precise generation of bias currents which significantly reduces power consumption and variation as compared with traditional implementations that use an internal resistor. The bias generation circuitry requires a 10 kΩ (1%) resistor connected between REXT and GND.

## 2.10. Differential Input Circuitry

The Si5318 provides a differential input for the clock input, CLKIN. This input is internally biased to a voltage of  $V_{ICM}$  (see Table 2 on page 6) and may be driven by a differential or single-ended driver circuit. For differential transmission lines, the termination resistor is connected externally as shown.

## 2.11. Differential Output Circuitry

The Si5318 utilizes a current mode logic (CML) architecture to drive the differential clock output, CLKOUT.

For single-ended output operation, simply connect to either CLKOUT+ or CLKOUT-, and leave the unused signal unconnected.

## 2.12. Power Supply Connections

The Si5318 incorporates an on-chip voltage regulator. The voltage regulator requires an external compensation circuit of one resistor and one capacitor to ensure stability over all operating conditions.

Internally, the Si5318 V<sub>DD33</sub> pins are connected to the on-chip voltage regulator input, and the V<sub>DD33</sub> pins also supply power to the device's LVTTTL I/O circuitry. The V<sub>DD25</sub> pins supply power to the core DSPLL circuitry and are also used for connection of the external compensation circuit.

# Si5318

The regulator's compensation circuit is in reality a resistor and a capacitor in series between the  $V_{DD25}$  node and ground. (See Figure 5 on page 13.) Typically, the resistor is incorporated into the capacitor's equivalent series resistance (ESR). The target RC time constant for this combination is 15 to 50  $\mu\text{s}$ . The capacitor used in the Si5318 evaluation board is a 33  $\mu\text{F}$  tantalum capacitor with an ESR of 0.8  $\Omega$ . This gives an RC time constant of 26.4  $\mu\text{s}$ . The Venkel part number, TA6R3TCR336KBR, is an example of a capacitor that meets these specs.

To get optimal performance from the Si5318 device, the power supply noise spectrum must comply with the plot in Figure 10. This plot shows the power supply noise tolerance mask for the Si5318. The customer should provide a 3.3 V supply that does not have noise density in excess of the amount shown in the diagram. However, the diagram cannot be used as spur criteria for a power supply that contains single tone noise.

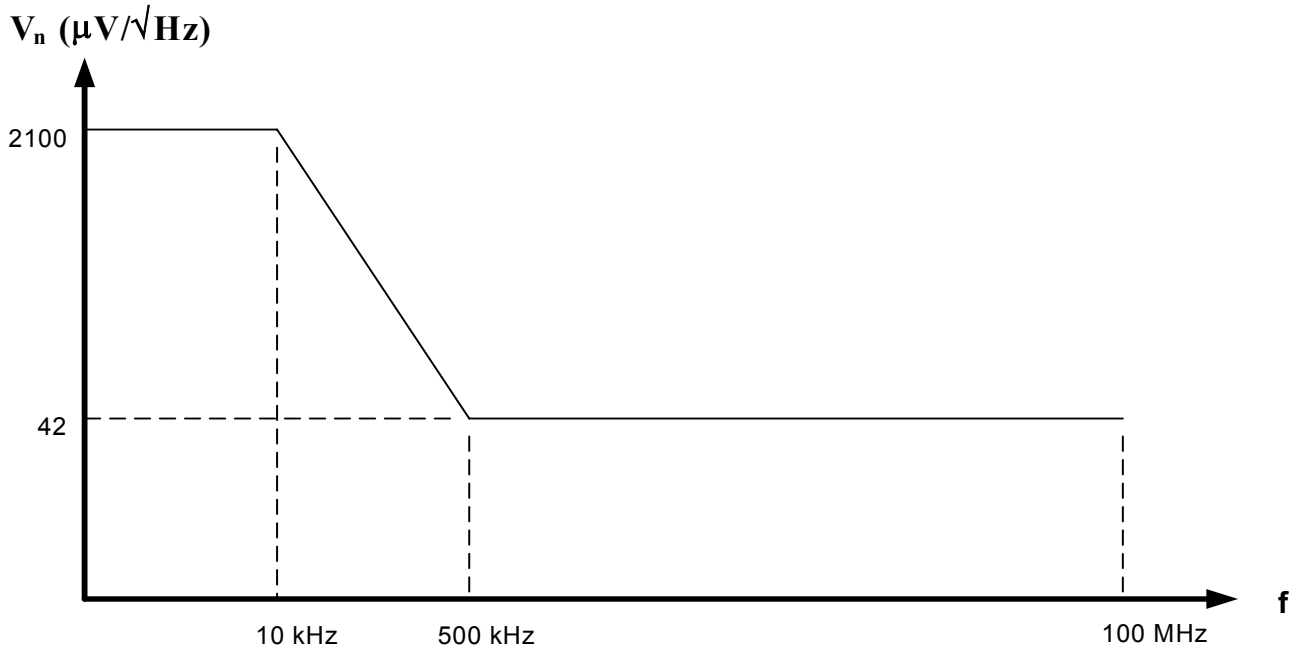

Figure 10. Power Supply Noise Tolerance Mask

## 2.13. Design and Layout Guidelines

Precision clock circuits are susceptible to board noise and EMI. To take precautions against unacceptable levels of board noise and EMI affecting performance of the Si5318, consider the following:

- Power the device from 3.3 V since the internal regulator provides at least 40 dB of isolation to the  $V_{DD25}$  pins (which power the PLL circuitry).
- Use an isolated local plane to connect the  $V_{DD25}$  pins. Avoid running signal traces over or below this plane without a ground plane in between.
- Route all I/O traces between ground planes as much as possible
- Maintain an input clock amplitude in the 200 mV<sub>PP</sub> to 500 mV<sub>PP</sub> differential range.
- Excessive high-frequency harmonics of the input clock should be minimized. The use of filters on the input clock signal can be used to remove high-frequency harmonics.



## 3. Pin Descriptions: Si5318

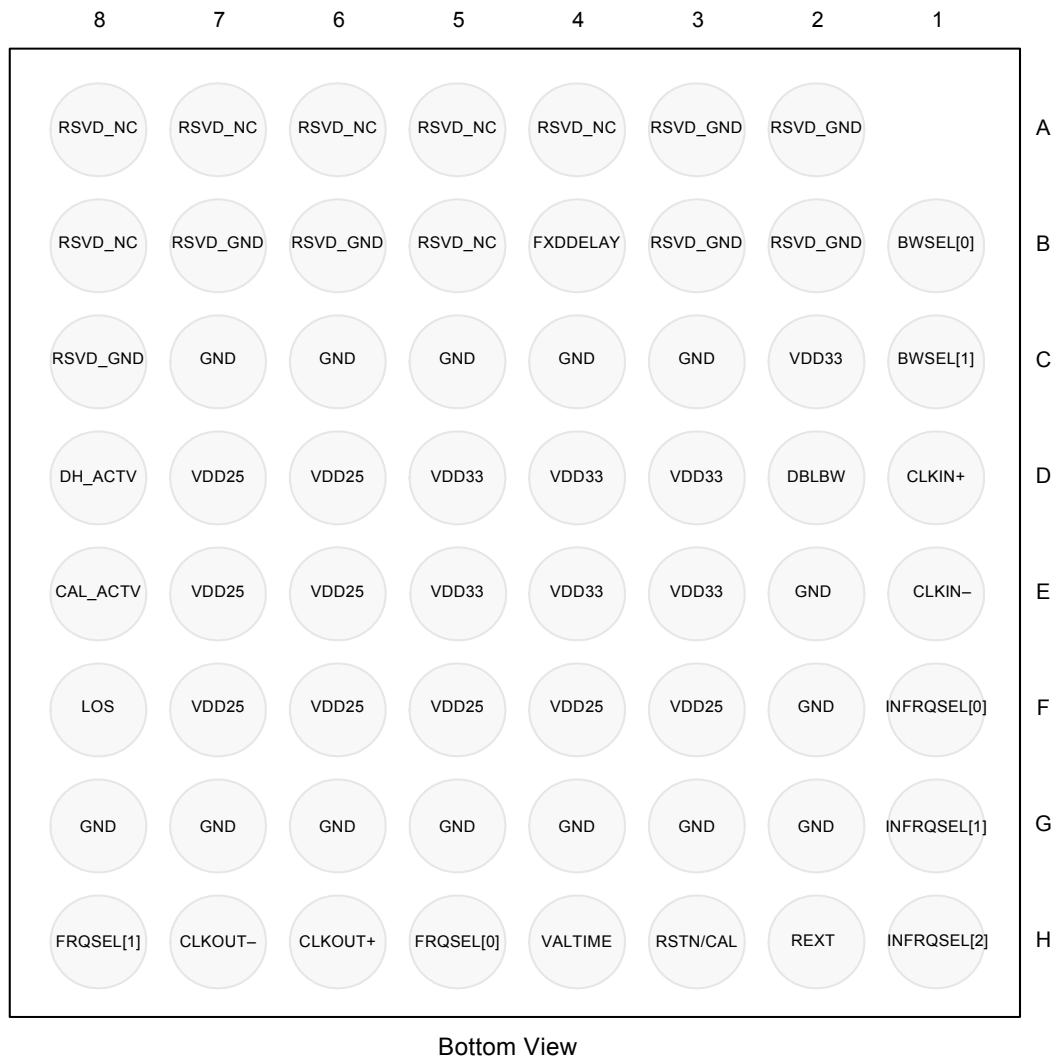

**Figure 11. Si5318 Pin Configuration (Bottom View)**

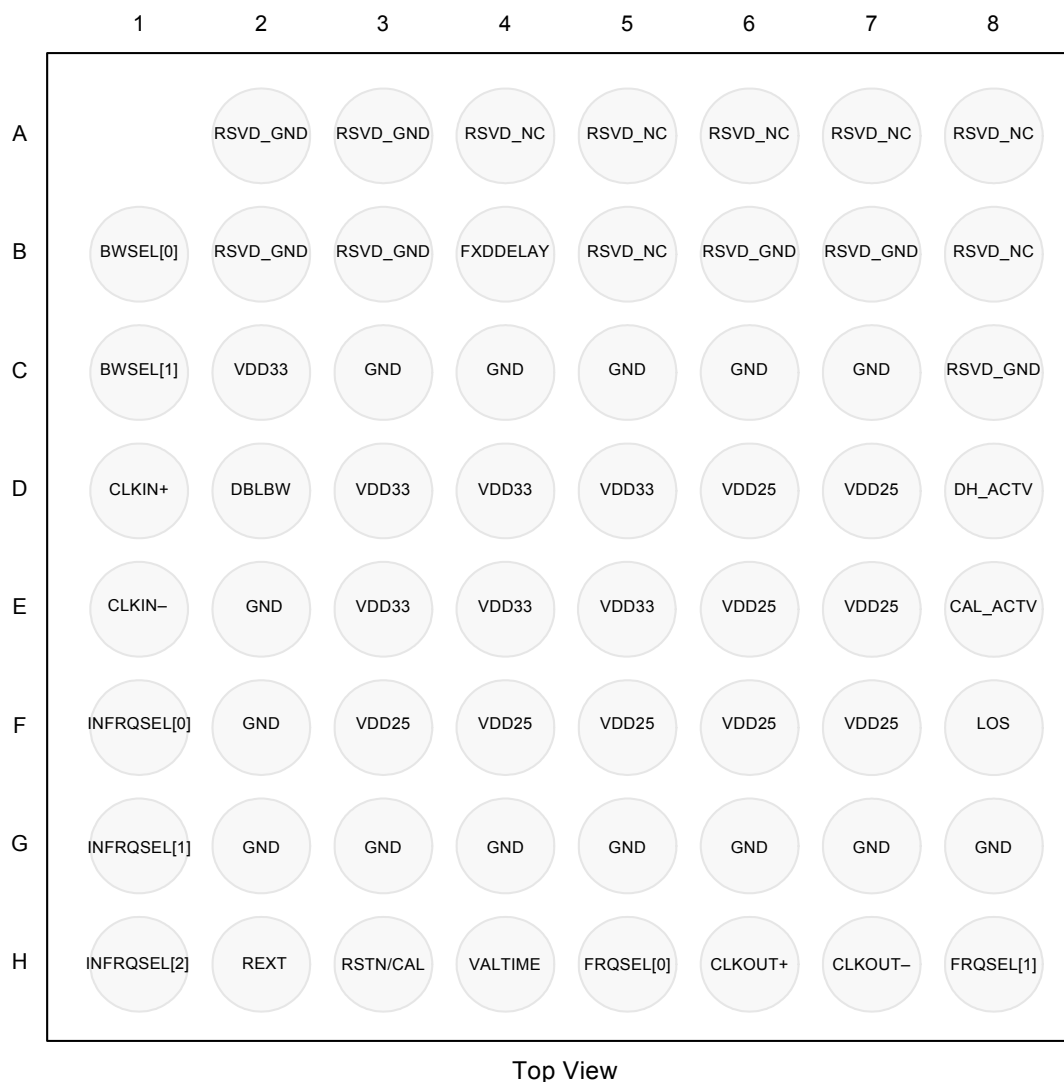

**Figure 12. Si5318 Pin Configuration (Transparent Top View)**

Table 10. Si5318 Pin Descriptions

Pin #	Pin Name	I/O	Signal Level	Description
B4	FXDDELAY	I*	LVTTL	<p><b>Fixed Delay Mode.</b></p> <p>Set high to disable hitless recovery from digital hold mode. This configuration is useful in applications that require a known, or constant, input-to-output phase relationship.</p> <p>When this pin is high, hitless switching from digital hold mode back to a valid clock input is disabled. When switching from digital hold mode to a valid clock input with FXDDELAY high, the clock output changes as necessary to re-establish the initial/default input-to-output phase relationship that is established after powerup or reset. The rate of change is determined by the setting of BWSEL[1:0].</p> <p>When this pin is low, hitless switching from digital hold mode back to a valid clock input is enabled. When switching from digital hold mode to a valid clock input with FXDDELAY low, the device enables "phase build out" to absorb the phase difference between the clock output and the clock input so that the phase change at the clock output is minimized. In this case, the input-to-output phase relationship following the transition out of digital hold mode is determined by the phase relationship at the time that switching occurs.</p> <p><b>Note:</b> FXDDELAY should remain at a static high or static low level during normal operation. Transitions on this pin are allowed only when the RSTN/CAL pin is low. FXDDELAY must be set high when DBLBW is set high.</p>
D1 E1	CLKIN+ CLKIN-	I	AC Coupled 200–500 mV <sub>PPD</sub> (See Table 2)	<p><b>System Clock Input.</b></p> <p>Clock input to the DSPLL circuitry. The frequency of the CLKIN signal is multiplied by the DSPLL to generate the CLKOUT clock output. The input-to-output frequency multiplication factor is set by selecting the clock input range and the clock output range. The frequency of the CLKIN clock input can be in the 19, 39, 78, or 155 MHz range (nominally 19.44, 38.88, 77.76, or 155.52 MHz) as indicated in Table 3 on page 7. The clock input frequency is selected using the INFRQSEL[2:0] pins. The clock output frequency is selected using the FRQSEL[1:0] pins.</p>
<p><b>*Note:</b> The LVTLL inputs on the Si5318 device have an internal pulldown mechanism that causes these inputs to default to a logic low state if the input is not driven from an external source.</p>				

Table 10. Si5318 Pin Descriptions (Continued)

Pin #	Pin Name	I/O	Signal Level	Description
F1 G1 H1	INFRQSEL[0] INFRQSEL[1] INFRQSEL[2]	I*	LVTTL	<p><b>Input Frequency Range Select.</b></p> <p>Pins(INFRQSEL[2:0]) select the frequency range for the input clock, CLKIN. (See Table 3 on page 7.)</p> <p>000 = Reserved. 001 = 19 MHz range. 010 = 39 MHz range. 011 = 78 MHz range. 100 = 155 MHz range. 101 = Reserved. 110 = Reserved. 111 = Reserved.</p>
F8	LOS	O	LVTTL	<p><b>Loss-of-Signal (LOS) Alarm for CLKIN.</b></p> <p>Active high output indicates that the Si5318 has detected missing pulses on the input clock signal. The LOS alarm is cleared after either 100 ms or 13 seconds of a valid CLKIN clock input, depending on the setting of the VALTIME input.</p>
D8	DH_ACTV	O	LVTTL	<p><b>Digital Hold Mode Active.</b></p> <p>Active high output indicates that the DSPLL is in digital hold mode. Digital hold mode locks the current state of the DSPLL and forces the DSPLL to continue generation of the output clock with no additional phase or frequency information from the input clock.</p>
H3	RSTN/CAL	I*	LVTTL	<p><b>Reset/Calibrate.</b></p> <p>When low, the internal circuitry enters the reset mode and all LVTTL outputs are forced into a high-impedance state. Also, the CLKOUT+ and CLKOUT- pins are forced to a nominal CML logic LOW and HIGH respectively. This feature is useful for in-circuit test applications.</p> <p>A low-to-high transition on RSTN/CAL initializes all digital logic to a known condition, enables the device outputs, and initiates self-calibration of the DSPLL. Upon completion of self-calibration, the DSPLL begins to lock to the selected clock input signal.</p>
<p><b>*Note:</b> The LVTTL inputs on the Si5318 device have an internal pulldown mechanism that causes these inputs to default to a logic low state if the input is not driven from an external source.</p>				

Table 10. Si5318 Pin Descriptions (Continued)

Pin #	Pin Name	I/O	Signal Level	Description
H6 H7	CLKOUT+ CLKOUT-	O	CML	<b>Differential Clock Output.</b> High frequency clock output. The frequency of the CLKOUT output is a multiple of the frequency of the CLKIN input. The input-to-output frequency multiplication factor is set by selecting the clock input range and the clock output range. The frequency of the CLKOUT clock output can be in the 19 or 155 MHz range as indicated in Table 3 on page 7. The clock output frequency is selected using the FRQSEL[1:0] pins. The clock input frequency is selected using the INFRQSEL[2:0] pins.
H5 H8	FRQSEL[0] FRQSEL[1]	I*	LVTTL	<b>Clock Output Frequency Range Select</b> Select frequency range of the clock output, CLKOUT. (See Table 3 on page 7.) 00 = Clock Driver Powerdown. 01 = 19 MHz Frequency Range. 10 = 155 MHz Frequency Range. 11 = Reserved.
B1 C1	BWSEL[0] BWSEL[1]	I*	LVTTL	<b>Bandwidth Select.</b> BWSEL[1:0] pins set the bandwidth of the loop filter within the DSPLL to 6400, 3200, 1600, or 800 Hz as indicated below. 00 = 3200 Hz 01 = 1600 Hz 10 = 800 Hz 11 = 6400 Hz <b>Note:</b> The loop filter bandwidth will be twice the value indicated when DBLBW is set high.
E8	CAL_ACTIV	O	LVTTL	<b>Calibration Mode Active.</b> This output is driven high during the DSPLL self-calibration and the subsequent initial lock acquisition period.
H4	VALTIME	I*	LVTTL	<b>Clock Validation Time for LOS.</b> VALTIME sets the clock validation times for recovery from an LOS alarm condition. When VALTIME is high, the validation time is approximately 13 seconds. When VALTIME is low, the validation time is approximately 100 ms.
A2, A3, B2, B3, B6, B7, C8	RSVD_GND	—	LVTTL	<b>Reserved—GND.</b> This pin must be tied to GND for normal operation.

**\*Note:** The LVTTL inputs on the Si5318 device have an internal pulldown mechanism that causes these inputs to default to a logic low state if the input is not driven from an external source.

Table 10. Si5318 Pin Descriptions (Continued)

Pin #	Pin Name	I/O	Signal Level	Description
A4–8, B5, B8	RSVD_NC	—	LVTTL	<b>Reserved—No Connect.</b> This pin must be left unconnected for normal operation.
C2, D3–D5, E3–E5	V <sub>DD33</sub>	V <sub>DD</sub>	Supply	<b>3.3 V Supply.</b> 3.3 V power is applied to the V <sub>DD33</sub> pins. Typical supply bypassing/decoupling for this configuration is indicated in the typical application diagram for 3.3 V supply operation.
D6, D7, E6, E7, F3–F7	V <sub>DD25</sub>	V <sub>DD</sub>	Supply	<b>2.5 V Supply.</b> These pins provide a means of connecting the compensation network for the on-chip regulator.
C3–C7, E2, F2, G2–G8	GND	GND	Supply	<b>Ground.</b> Must be connected to system ground. Minimize the ground path impedance for optimal performance of the device.
H2	REXT	I	Analog	<b>External Biasing Resistor.</b> Used by on-chip circuitry to establish bias currents within the device. This pin must be connected to GND through a 10 k $\Omega$ (1%) resistor.
D2	DBLBW	I*	LVTTL	<b>Double Bandwidth</b> Active high input to boost the selected bandwidth 2x. When this pin is high, the loop filter bandwidth selected on BWSEL[1:0] is doubled. When this pin is high, FXDDELAY must also be high.
<b>*Note:</b> The LVTLL inputs on the Si5318 device have an internal pulldown mechanism that causes these inputs to default to a logic low state if the input is not driven from an external source.				

## 4. Ordering Guide

Part Number	Package	Temperature
Si5318-X-BC	63-Ball CBGA	-20 to 85 °C
<b>Note:</b> "X" denotes product revision.		

## 5. Package Outline

Figure 13 illustrates the package details for the Si5318. Table 11 lists the values for the dimensions shown in the illustration.

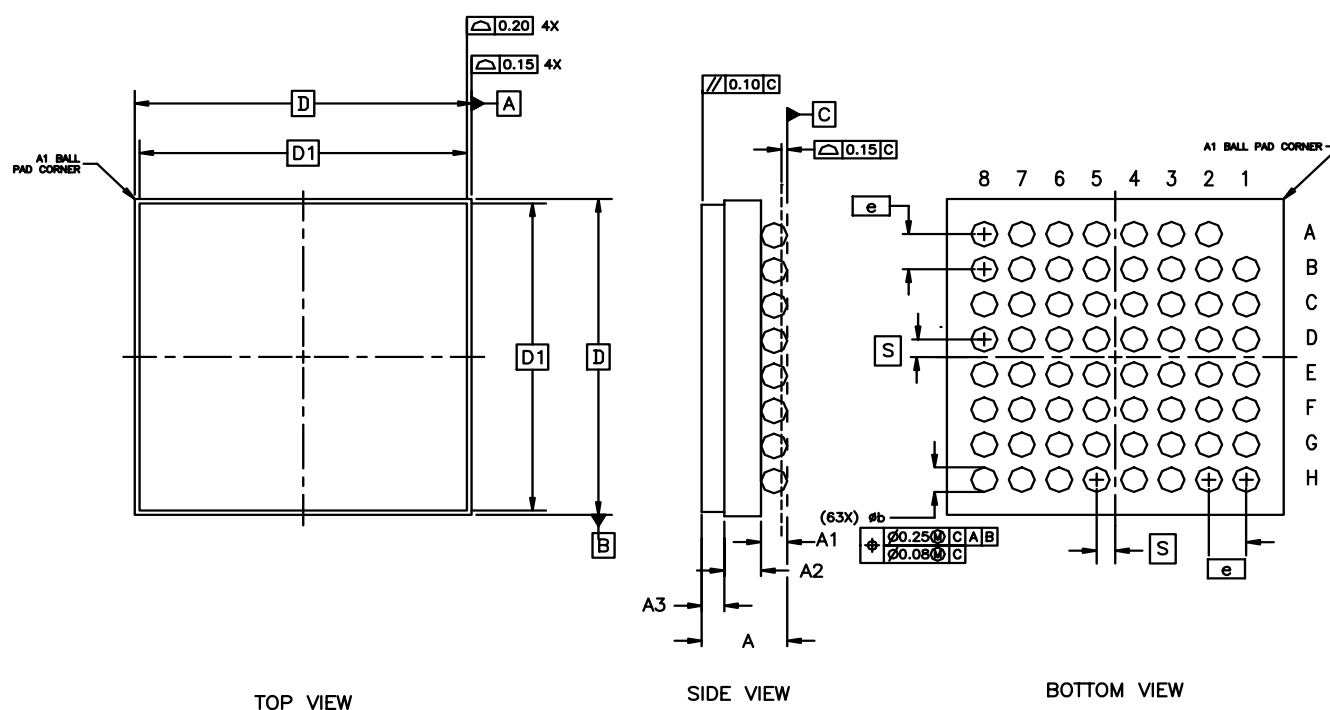
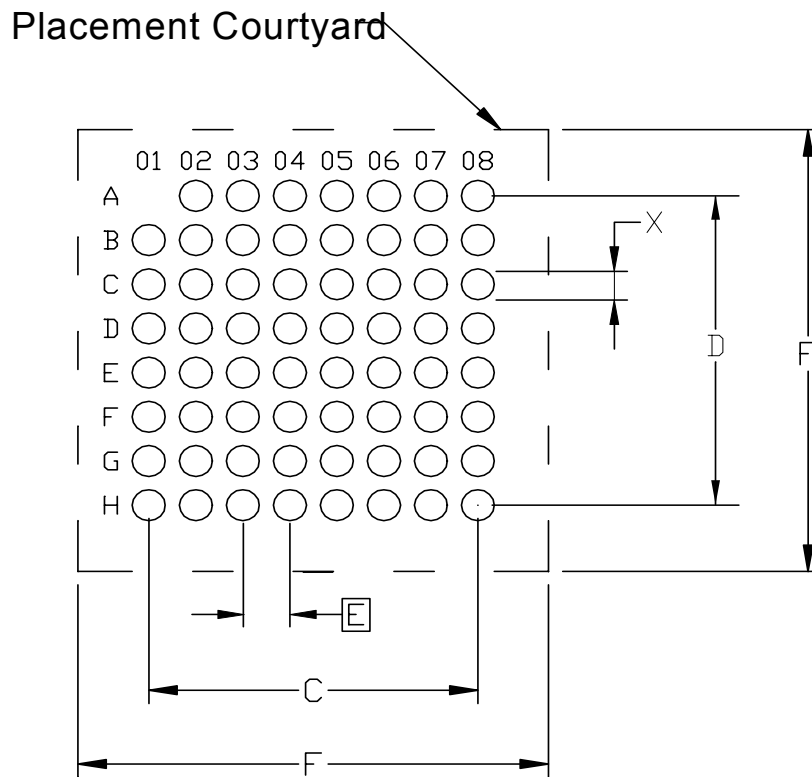

Figure 13. 63-Ball Ceramic Ball Grid Array (CBGA)

Table 11. Package Drawing Dimensions

Dimension	Description	Minimum	Nominal	Maximum
A	Total Package Height	2.13	2.28	2.43
A1	Standoff	0.60	0.70	0.80
A2	Ceramic Thickness	0.88	0.98	1.08
A3	Mold Cap Thickness	0.55	0.60	0.65
b	Solder Ball Diameter	0.65	0.70	0.75
D	Ceramic Body Size	8.85	9.00	9.15
D1	Mold Cap Size	8.55	8.75	8.95
e	Solder Ball Pitch	1.00 BSC		
S	Pitch to Centerline	0.50 BSC		

## 6. 9x9 mm CBGA Card Layout



**Table 12. Recommended Land Pattern Dimensions**

Symbol	Parameter	Dimension			Notes
		Min	Nom	Max	
C	Column Width	—	7.00 REF	—	
D	Row Height	—	7.00 REF	—	
E	Pad Pitch	—	1.00 BSC	—	
F	Placement Courtyard	10.00	—	—	1
X	Pad Diameter	0.64	0.68	0.72	2, 3

**Notes:**

1. The Placement Courtyard is the minimum keep-out area required to assure assembly clearances.
2. Pad Diameter is Copper Defined (Non-Solder Mask Defined/NSMD).
3. OSP Surface Finish Recommended.
4. Controlling dimension is millimeters.
5. Land Pad Dimensions comply with IPC-SM-782 guidelines.
6. Target solder paste volume per pad is  $0.065 \text{ mm}^3 \pm 0.010 \text{ mm}^3$  ( $4000 \text{ mils}^3 \pm 600 \text{ mils}^3$ ). Recommended stencil aperture dimensions to achieve target solder paste volume are  $0.191 \text{ mm}$  thick x  $0.68 \pm 0.01 \text{ mm}$  diameter, with a  $0.025 \text{ mm}$  taper.
7. Recommended stencil type is chemically etched stainless steel with circularly tapered apertures.

## DOCUMENT CHANGE LIST

### Revision 0.9 to Revision 1.0

- Updated  $\theta_{JA}$  in Table 6, "Thermal Characteristics," on page 12.

## CONTACT INFORMATION

### Silicon Laboratories Inc.

4635 Boston Lane

Austin, TX 78735

Tel: 1+(512) 416-8500

Fax: 1+(512) 416-9669

Toll Free: 1+(877) 444-3032

Email: [Clockinfo@silabs.com](mailto:Clockinfo@silabs.com)

Internet: [www.silabs.com](http://www.silabs.com)

The information in this document is believed to be accurate in all respects at the time of publication but is subject to change without notice. Silicon Laboratories assumes no responsibility for errors and omissions, and disclaims responsibility for any consequences resulting from the use of information included herein. Additionally, Silicon Laboratories assumes no responsibility for the functioning of undescribed features or parameters. Silicon Laboratories reserves the right to make changes without further notice. Silicon Laboratories makes no warranty, representation or guarantee regarding the suitability of its products for any particular purpose, nor does Silicon Laboratories assume any liability arising out of the application or use of any product or circuit, and specifically disclaims any and all liability, including without limitation consequential or incidental damages. Silicon Laboratories products are not designed, intended, or authorized for use in applications intended to support or sustain life, or for any other application in which the failure of the Silicon Laboratories product could create a situation where personal injury or death may occur. Should Buyer purchase or use Silicon Laboratories products for any such unintended or unauthorized application, Buyer shall indemnify and hold Silicon Laboratories harmless against all claims and damages.

Silicon Laboratories, Silicon Labs, and DSPLL are trademarks of Silicon Laboratories Inc.

Other products or brandnames mentioned herein are trademarks or registered trademarks of their respective holders.

## Looking for pricing, stock, or lifecycle information?

Click below to explore more details on WIN SOURCE:

 [View SI5318-G-BC on WIN SOURCE](#)

 [Silicon Labs](#) Information

## Optimize Your Supply Chain with WIN SOURCE Solutions

-  Global Sourcing Solution
-  Obsolete Management
-  Cost Control Management
-  Shortage Management
-  Alternative Solution
-  Excess Inventory Management