



**THE DATASHEET OF  
SN74CBT3244DBRG4**



## SN74CBT3244 Octal FET Bus Switch

### 1 Features

- High-Bandwidth Data Path (Up to 200 MHz)
- Control Inputs Can Be Driven by TTL or 5-V/3.3-V CMOS Outputs
- Low and Flat ON-State Resistance ( $r_{on}$ ) Characteristics Over Operating Range ( $r_{on} = 5 \Omega$  Typical)
- Bidirectional Data Flow With Near-Zero Propagation Delay
- Low Input/Output Capacitance Minimizes Loading and Signal Distortion ( $C_{io(OFF)} = 6 \text{ pF}$  Typical)
- Low Power Consumption ( $I_{CC} = 50 \mu\text{A}$  Maximum)
- $V_{CC}$  Operating Range From 4.5 V to 5 V
- Data I/Os Support 0- to 5-V Signaling Levels (0.8 V, 1.2 V, 1.5 V, 1.8 V, 2.5 V, 3.3 V, 5 V)
- Standard '244-Type Pinout

### 2 Applications

- Multi-Processor Communications
- Test and Measurement Systems
- Factory Automation Control Boards
- Building Automation Control Boards

### 3 Description

The SN74CBT3244 device provides eight bits of high-speed TTL-compatible bus switching. The SOIC, SSOP, TSSOP, and TVSOP packages provide a standard '244 device pinout. The low ON-state resistance of the switch allows connections to be made with minimal propagation delay. The device is organized as two 4-bit low-impedance switches with separate output-enable ( $\overline{OE}$ ) inputs.

#### Device Information<sup>(1)</sup>

PART NUMBER	PACKAGE	BODY SIZE (NOM)
SN74CBT3244RGY	VQFN (20)	3.35 mm x 4.35 mm
SN74CBT3244DW	SOIC (20)	9.97 mm x 12.60 mm
SN74CBT3244DB	SSOP (20)	5.80 mm x 8.55 mm
SN74CBT3244DBQ	SSOP (20)	8.65 mm x 3.90 mm
SN74CBT3244PW	TSSOP (20)	5.00 mm x 4.40 mm

(1) For all available packages, see the orderable addendum at the end of the data sheet.

#### Simplified Schematic

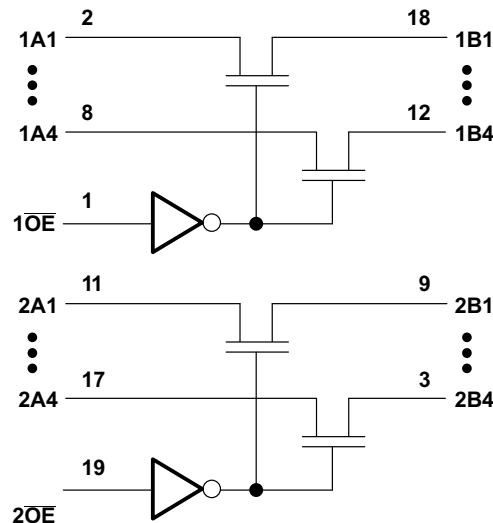

## Table of Contents

<b>1 Features</b> ..... 1 <b>2 Applications</b> ..... 1 <b>3 Description</b> ..... 1 <b>4 Revision History</b> ..... 2 <b>5 Pin Configuration and Functions</b> ..... 3 <b>6 Specifications</b> ..... 4 6.1 Absolute Maximum Ratings ..... 4 6.2 ESD Ratings..... 4 6.3 Recommended Operating Conditions ..... 4 6.4 Thermal Information Package..... 4 6.5 Electrical Characteristics..... 5 6.6 Switching Characteristics ..... 5 6.7 Typical Characteristics ..... 5 <b>7 Parameter Measurement Information</b> ..... 6 <b>8 Detailed Description</b> ..... 7 8.1 Overview ..... 7 8.2 Functional Block Diagram ..... 7	8.3 Feature Description..... 7 8.4 Device Functional Modes..... 7 <b>9 Application and Implementation</b> ..... 8 9.1 Application Information..... 8 9.2 Typical Application ..... 8 <b>10 Power Supply Recommendations</b> ..... 9 <b>11 Layout</b> ..... 10 11.1 Layout Guidelines ..... 10 11.2 Layout Example ..... 10 <b>12 Device and Documentation Support</b> ..... 11 12.1 Documentation Support ..... 11 12.2 Community Resources..... 11 12.3 Trademarks ..... 11 12.4 Electrostatic Discharge Caution..... 11 12.5 Glossary ..... 11 <b>13 Mechanical, Packaging, and Orderable Information</b> ..... 11
--	---

## 4 Revision History

### Changes from Revision N (September 2003) to Revision O

**Page**

- Added *Pin Configuration and Functions* section, *ESD Ratings* table, *Feature Description* section, *Device Functional Modes*, *Application and Implementation* section, *Power Supply Recommendations* section, *Layout* section, *Device and Documentation Support* section, and *Mechanical, Packaging, and Orderable Information* section ..... 1

## 5 Pin Configuration and Functions

DB, DBQ, DGV, or PW Package  
20-Pin SSOP, TVSOP, or TSSOP  
Top View

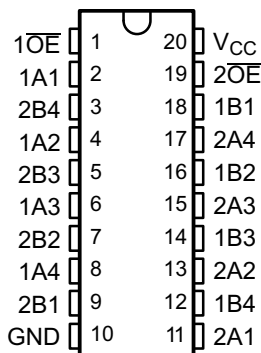

RGY Package  
20-Pin VQFN  
Top View

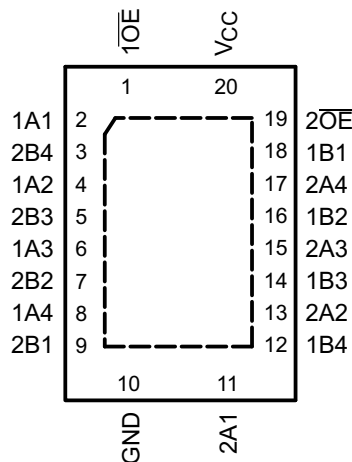

### Pin Functions

NAME	PIN	I/O	DESCRIPTION
	DB, DBQ, DGV, PW, SSOP, TVSOP, TSSOP, VQFN		
1A1	2	I/O	Transceiver I/O pin
1A2	4	I/O	Transceiver I/O pin
1A3	6	I/O	Transceiver I/O pin
1A4	8	I/O	Transceiver I/O pin
2A1	11	I/O	Transceiver I/O pin
2A2	13	I/O	Transceiver I/O pin
2A3	15	I/O	Transceiver I/O pin
2A4	17	I/O	Transceiver I/O pin
1B1	18	I/O	Transceiver I/O pin
1B2	16	I/O	Transceiver I/O pin
1B3	14	I/O	Transceiver I/O pin
1B4	12	I/O	Transceiver I/O pin
2B1	9	I/O	Transceiver I/O pin
2B2	7	I/O	Transceiver I/O pin
2B3	5	I/O	Transceiver I/O pin
2B4	3	I/O	Transceiver I/O pin
$\overline{1OE}$	1	I	Output Enable. When high A and B are disconnected, when Low A and B are connected
$\overline{2OE}$	19	I	Output Enable. When high A and B are disconnected, when Low A and B are connected
GND	10	—	Ground
V <sub>CC</sub>	20	—	Power pin

## 6 Specifications

### 6.1 Absolute Maximum Ratings

over operating free-air temperature range (unless otherwise noted)<sup>(1)</sup>

	MIN	MAX	UNIT
Supply voltage, $V_{CC}$	-0.5	7	V
Input voltage, $V_I$ <sup>(2)</sup>	-0.5	7	V
Continuous channel current		128	mA
Clamp current, $I_K$ ( $V_{I/O} < 0$ )		-50	mA
Storage temperature, $T_{stg}$	-65	150	°C

- (1) Stresses beyond those listed under *Absolute Maximum Ratings* may cause permanent damage to the device. These are stress ratings only, which do not imply functional operation of the device at these or any other conditions beyond those indicated under *Recommended Operating Conditions*. Exposure to absolute-maximum-rated conditions for extended periods may affect device reliability.
- (2) The input and output negative-voltage ratings may be exceeded if the input and output clamp-current ratings are observed.

### 6.2 ESD Ratings

		VALUE	UNIT
$V_{(ESD)}$ Electrostatic discharge	Human body model (HBM), per ANSI/ESDA/JEDEC JS-001 <sup>(1)</sup>	±1500	V
	Charged-device model (CDM), per JEDEC specification JESD22-C101 <sup>(2)</sup>	±500	

- (1) JEDEC document JEP155 states that 500-V HBM allows safe manufacturing with a standard ESD control process.
- (2) JEDEC document JEP157 states that 250-V CDM allows safe manufacturing with a standard ESD control process.

### 6.3 Recommended Operating Conditions

over operating free-air temperature range (unless otherwise noted)<sup>(1)</sup>

		MIN	MAX	UNIT
$V_{CC}$	Supply voltage	4.5	5.5	V
$V_{IH}$	High-level control input voltage	2		V
$V_{IL}$	Low-level control input voltage		0.8	V
$T_A$	Operating free-air temperature	-40	85	°C

- (1) All unused control inputs of the device must be held at  $V_{CC}$  or GND to ensure proper device operation. Refer to the TI application report, *Implications of Slow or Floating CMOS Inputs*, [SCBA004](#).

### 6.4 Thermal Information Package

THERMAL METRIC <sup>(1)(2)</sup>	SN74CBT3244					UNIT
	DB (SSOP)	DBQ (SSOP)	DGV (TVSOP)	PW (TSSOP)	RGY (VQFN)	
	20 PINS	20 PINS	20 PINS	20 PINS	20 PINS	
$R_{\theta JA}$ Junction-to-ambient thermal resistance	70	68	92	83	37	°C/W

- (1) For more information about traditional and new thermal metrics, see the *Semiconductor and IC Package Thermal Metrics* application report, [SPRA953](#).
- (2) The package thermal impedance is calculated in accordance with JESD 51-7.

## 6.5 Electrical Characteristics

over operating free-air temperature range (unless otherwise noted)

PARAMETER	TEST CONDITIONS			MIN	TYP <sup>(1)</sup>	MAX	UNIT
$V_{IK}$	$V_{CC} = 4.5\text{ V}$	$I_I = -18\text{ mA}$				-1.2	V
$I_I$	$V_{CC} = 5.5\text{ V}$	$V_I = 5.5\text{ V or GND}$				$\pm 5$	$\mu\text{A}$
$I_{CC}$	$V_{CC} = 5.5\text{ V}$	$I_O = 0,$	$V_I = V_{CC}\text{ or GND}$			50	$\mu\text{A}$
$\Delta I_{CC}^{(2)}$ Control inputs	$V_{CC} = 5.5\text{ V}$	One input at 3.4 V,	Other inputs at $V_{CC}$ or GND			3.5	mA
$C_i$ Control inputs	$V_I = 3\text{ V or 0}$				3		pF
$C_{io(OFF)}$	$V_O = 3\text{ V or 0}$	$\overline{OE} = V_{CC}$			6		pF
$r_{on}^{(3)}$	$V_{CC} = 4.5\text{ V}$	$V_I = 0\text{ V}$	$I_I = 64\text{ mA}$		5	7	$\Omega$
			$I_I = 30\text{ mA}$		5	7	
		$V_I = 2.4\text{ V}$	$I_I = 15\text{ mA}$		10	15	

(1) All typical values are at  $V_{CC} = 5\text{ V}, T_A = 25^\circ\text{C}$ .

(2) This is the increase in supply current for each input that is at the specified TTL voltage level, rather than  $V_{CC}$  or GND.

(3) Measured by the voltage drop between the A and the B terminals at the indicated current through the switch. On-state resistance is determined by the lowest voltage of the two (A or B) terminals.

## 6.6 Switching Characteristics

over operating free-air temperature range (unless otherwise noted)

PARAMETER	FROM (INPUT)	TO (OUTPUT)	MIN	TYP	MAX	UNIT
$t_{pd}^{(1)}$	A or B	B or A			0.25	ns
$t_{en}$	$\overline{OE}$	A or B	1		8.9	ns
$t_{dis}$	OE	A or B	1		7.4	ns

(1) This propagation delay is the calculated RC time constant of the typical on-state resistance of the switch and the specified load capacitance, when driven by an ideal voltage source (zero output impedance).

## 6.7 Typical Characteristics

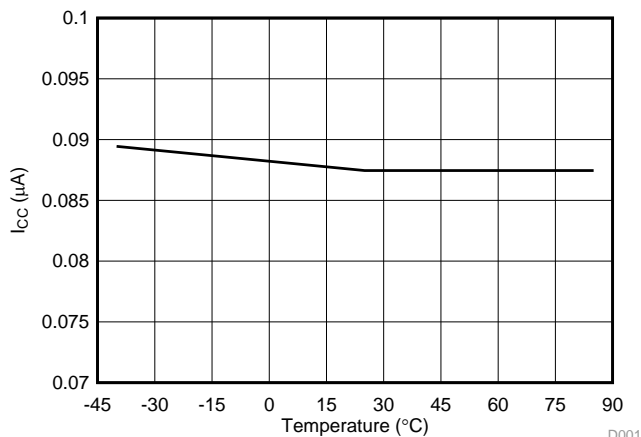
Note device variation mentioned in [Electrical Characteristics](#)
**Figure 1.  $I_{CC}$  variation With Temperature**

## 7 Parameter Measurement Information

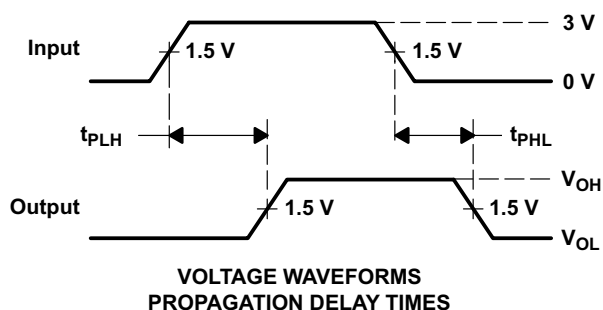
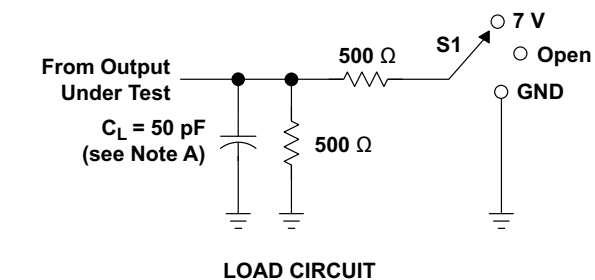

TEST	S1
$t_{pd}$	Open
$t_{PLZ}/t_{PZL}$	7 V
$t_{PHZ}/t_{PZH}$	Open

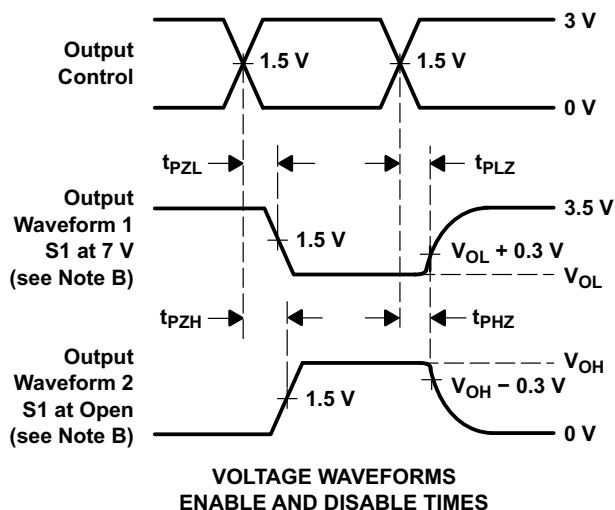

- NOTES:
- A.  $C_L$  includes probe and jig capacitance.
  - B. Waveform 1 is for an output with internal conditions such that the output is low except when disabled by the output control. Waveform 2 is for an output with internal conditions such that the output is high except when disabled by the output control.
  - C. All input pulses are supplied by generators having the following characteristics:  $PRR \leq 10 \text{ MHz}$ ,  $Z_O = 50 \Omega$ ,  $t_r \leq 2.5 \text{ ns}$ ,  $t_f \leq 2.5 \text{ ns}$ .
  - D. The outputs are measured one at a time with one transition per measurement.
  - E.  $t_{PLZ}$  and  $t_{PHZ}$  are the same as  $t_{dis}$ .
  - F.  $t_{PZL}$  and  $t_{PZH}$  are the same as  $t_{en}$ .
  - G.  $t_{PLH}$  and  $t_{PHL}$  are the same as  $t_{pd}$ .
  - H. All parameters and waveforms are not applicable to all devices.

Figure 2. Load Circuit and Voltage Waveforms

## 8 Detailed Description

### 8.1 Overview

The SN74CBT3244 has eight bits of high-speed TTL-compatible bus switching. The switches are grouped in the 2 groups of 4 bits each. Each group has output-enabled inputs to allow signals to pass between A and B ports. The signals can travel from A port to B port or vice versa.

The low ON-state resistance of the switch allows connections to be made with minimal propagation delay. The device is ideal for switching high speed digital signals between microprocessors and peripheral devices which is useful in test applications, measurement applications, and control boards for factory automation.

### 8.2 Functional Block Diagram

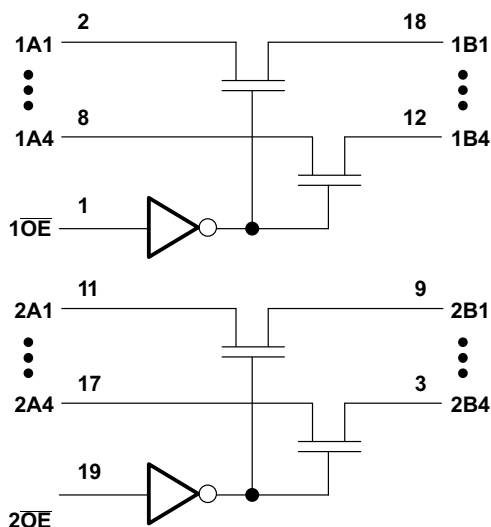

Figure 3. Simplified Schematic

### 8.3 Feature Description

The SN74CBT3244 device support same pin configuration as industry standard '244. This device has a near zero propagation delay allowing high speed signal switching up to 200 Mhz. The signals see lower distortion since the device has low ON-resistance (5 Ω) coupled with low-output capacitance (6 pF) . SN74CBT3244 has a very low power consumption in idle state consuming  $I_{CC}$  of 50 μA only allowing power-saving for the system. The device supports signal inputs any where between 0 V to 5 V.

### 8.4 Device Functional Modes

The device is organized as two 4-bit low-impedance switches with separate output-enable ( $\overline{OE}$ ) inputs. The Output Enable  $\overline{OE}$  is active low, implying when low A port is connected to B port. This switch is bidirectional in nature. Asserting  $\overline{OE}$  high will disconnect A port from B port. To ensure the high-impedance state during power up or power down,  $\overline{OE}$  should be tied to  $V_{CC}$  through a pullup resistor. The minimum value of the resistor is determined by the current-sinking capability of the driver.

Table 1. Function Table  
(Each 4-Bit Bus Switch)

INPUT $\overline{OE}$	FUNCTION
L	A port = B port
H	Disconnect

## 9 Application and Implementation

### NOTE

Information in the following applications sections is not part of the TI component specification, and TI does not warrant its accuracy or completeness. TI's customers are responsible for determining suitability of components for their purposes. Customers should validate and test their design implementation to confirm system functionality.

### 9.1 Application Information

The SN74CBT3244 device can be used to control up to 4 bits with 2 channels simultaneously. The application shown in [Figure 4](#) is a 8-bit bus being controlled. The  $\overline{OE}$  pins are used to control the chip from the bus controller. This is a generic example and can apply to many situations. If an application requires fewer than 8 bits, ensure that the A side is tied either high or low on unused channels.

### 9.2 Typical Application

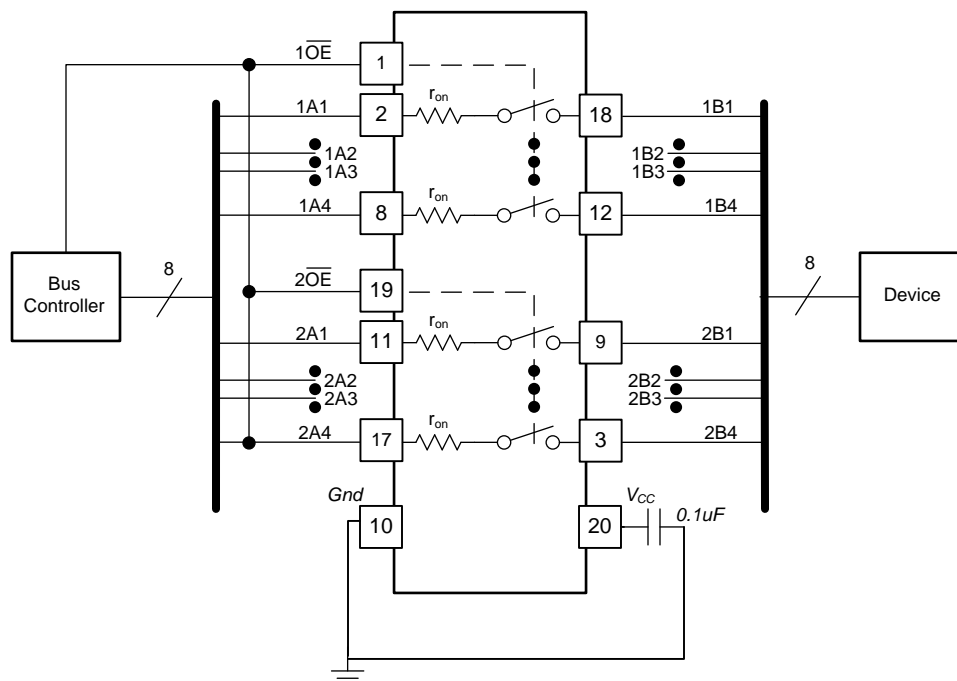

**Figure 4. Typical Application**

#### 9.2.1 Design Requirements

A 0.1- $\mu$ F bypass capacitor should be placed between each  $V_{CC}$  pin and GND. Each capacitor should be placed as close as possible to the SN74CBT3244 device.

#### 9.2.2 Detailed Design Procedure

- Recommended input conditions:
  - For specified high and low levels, see  $V_{IH}$  and  $V_{IL}$  in [Electrical Characteristics](#)
  - Inputs and outputs are overvoltage tolerant, which allows them to go as high as 5.5 V at any valid  $V_{CC}$
- Recommended output conditions:
  - Load currents must not exceed  $\pm 64$  mA per channel
- Frequency selection criterion:
  - Added trace resistance or capacitance can reduce maximum frequency capability; use layout practices as directed in [Layout Guidelines](#)

## Typical Application (continued)

### 9.2.3 Application Curve

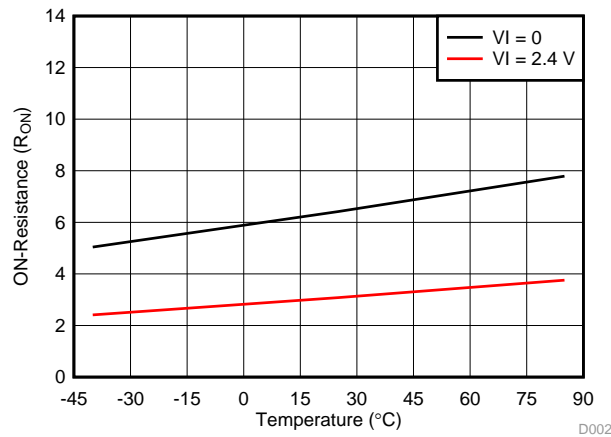

Figure 5. ON-Resistance ( $R_{on}$ ) Variation vs Temperature

(1) Note device variation mentioned in [Electrical Characteristics](#)

## 10 Power Supply Recommendations

The power supply can be any voltage between the minimum and maximum supply voltage rating listed in the [Absolute Maximum Ratings](#) table.

Each  $V_{CC}$  terminal should have a good bypass capacitor to prevent power disturbance. For devices with a single supply, a 0.1- $\mu\text{F}$  bypass capacitor is recommended. If multiple pins are labeled  $V_{CC}$ , then a 0.01- $\mu\text{F}$  or 0.022- $\mu\text{F}$  capacitor is recommended for each  $V_{CC}$  because the  $V_{CC}$  pins are tied together internally. For devices with dual-supply pins operating at different voltages, for example  $V_{CC}$  and  $V_{DD}$ , a 0.1- $\mu\text{F}$  bypass capacitor is recommended for each supply pin. To reject different frequencies of noise, use multiple bypass capacitors in parallel. Capacitors with values of 0.1  $\mu\text{F}$  and 1  $\mu\text{F}$  are commonly used in parallel. The bypass capacitor must be installed as close to the power terminal as possible for best results.

## 11 Layout

### 11.1 Layout Guidelines

Reflections and matching are closely related to the loop antenna theory but are different enough to be discussed separately from the theory. When a PCB trace turns a corner at a 90° angle, a reflection can occur. A reflection occurs primarily because of the change of width of the trace. At the apex of the turn, the trace width increases to 1.414 times the width. This increase upsets the transmission-line characteristics, especially the distributed capacitance and self-inductance of the trace, which results in the reflection. Not all PCB traces can be straight; therefore, some traces must turn corners. Figure 6 shows progressively better techniques of rounding corners. Only the last example (BEST) maintains constant trace width and minimizes reflections.

### 11.2 Layout Example

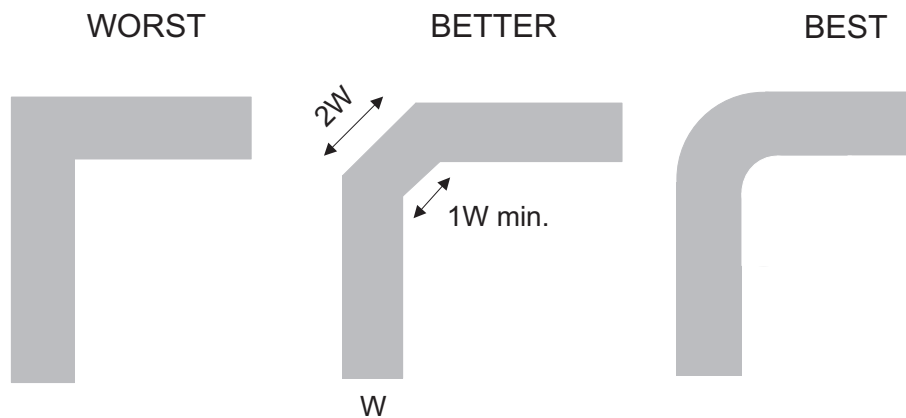

**Figure 6. Trace Example**

## 12 Device and Documentation Support

### 12.1 Documentation Support

#### 12.1.1 Related Documentation

For related documentation see the following:

- *Implications of Slow or Floating CMOS Inputs*, [SCBA004](#)
- *Selecting the Right Texas Instruments Signal Switch*, [SZZA030](#)

### 12.2 Community Resources

The following links connect to TI community resources. Linked contents are provided "AS IS" by the respective contributors. They do not constitute TI specifications and do not necessarily reflect TI's views; see TI's [Terms of Use](#).

**TI E2E™ Online Community** *TI's Engineer-to-Engineer (E2E) Community*. Created to foster collaboration among engineers. At [e2e.ti.com](#), you can ask questions, share knowledge, explore ideas and help solve problems with fellow engineers.

**Design Support** *TI's Design Support* Quickly find helpful E2E forums along with design support tools and contact information for technical support.

### 12.3 Trademarks

E2E is a trademark of Texas Instruments.  
All other trademarks are the property of their respective owners.

### 12.4 Electrostatic Discharge Caution



These devices have limited built-in ESD protection. The leads should be shorted together or the device placed in conductive foam during storage or handling to prevent electrostatic damage to the MOS gates.

### 12.5 Glossary

[SLYZ022](#) — *TI Glossary*.

This glossary lists and explains terms, acronyms, and definitions.

## 13 Mechanical, Packaging, and Orderable Information

The following pages include mechanical, packaging, and orderable information. This information is the most current data available for the designated devices. This data is subject to change without notice and revision of this document. For browser-based versions of this data sheet, refer to the left-hand navigation.

**PACKAGING INFORMATION**

Orderable Device	Status (1)	Package Type	Package Drawing	Pins	Package Qty	Eco Plan (2)	Lead finish/ Ball material (6)	MSL Peak Temp (3)	Op Temp (°C)	Device Marking (4/5)	Samples
SN74CBT3244DBQR	LIFEBUY	SSOP	DBQ	20	2500	RoHS & Green	NIPDAU	Level-2-260C-1 YEAR	-40 to 85	CBT3244	
SN74CBT3244DBR	NRND	SSOP	DB	20	2000	RoHS & Green	NIPDAU	Level-1-260C-UNLIM	-40 to 85	CU244	
SN74CBT3244DGVR	NRND	TVSOP	DGV	20	2000	RoHS & Green	NIPDAU	Level-1-260C-UNLIM	-40 to 85	CU244	
SN74CBT3244DW	NRND	SOIC	DW	20	25	RoHS & Green	NIPDAU	Level-1-260C-UNLIM	-40 to 85	CBT3244	
SN74CBT3244DWR	NRND	SOIC	DW	20	2000	RoHS & Green	NIPDAU	Level-1-260C-UNLIM	-40 to 85	CBT3244	
SN74CBT3244PW	NRND	TSSOP	PW	20	70	RoHS & Green	NIPDAU	Level-1-260C-UNLIM	-40 to 85	CU244	
SN74CBT3244PWR	LIFEBUY	TSSOP	PW	20	2000	RoHS & Green	NIPDAU	Level-1-260C-UNLIM	-40 to 85	CU244	
SN74CBT3244PWRE4	LIFEBUY	TSSOP	PW	20	2000	RoHS & Green	NIPDAU	Level-1-260C-UNLIM	-40 to 85	CU244	
SN74CBT3244PWRG4	LIFEBUY	TSSOP	PW	20	2000	RoHS & Green	NIPDAU	Level-1-260C-UNLIM	-40 to 85	CU244	
SN74CBT3244RGYR	LIFEBUY	VQFN	RGY	20	3000	RoHS & Green	NIPDAU	Level-2-260C-1 YEAR	-40 to 85	CU244	

(1) The marketing status values are defined as follows:

**ACTIVE:** Product device recommended for new designs.

**LIFEBUY:** TI has announced that the device will be discontinued, and a lifetime-buy period is in effect.

**NRND:** Not recommended for new designs. Device is in production to support existing customers, but TI does not recommend using this part in a new design.

**PREVIEW:** Device has been announced but is not in production. Samples may or may not be available.

**OBSOLETE:** TI has discontinued the production of the device.

(2) **RoHS:** TI defines "RoHS" to mean semiconductor products that are compliant with the current EU RoHS requirements for all 10 RoHS substances, including the requirement that RoHS substance do not exceed 0.1% by weight in homogeneous materials. Where designed to be soldered at high temperatures, "RoHS" products are suitable for use in specified lead-free processes. TI may reference these types of products as "Pb-Free".

**RoHS Exempt:** TI defines "RoHS Exempt" to mean products that contain lead but are compliant with EU RoHS pursuant to a specific EU RoHS exemption.

**Green:** TI defines "Green" to mean the content of Chlorine (Cl) and Bromine (Br) based flame retardants meet JS709B low halogen requirements of <=1000ppm threshold. Antimony trioxide based flame retardants must also meet the <=1000ppm threshold requirement.

(3) MSL, Peak Temp. - The Moisture Sensitivity Level rating according to the JEDEC industry standard classifications, and peak solder temperature.

(4) There may be additional marking, which relates to the logo, the lot trace code information, or the environmental category on the device.

(5) Multiple Device Markings will be inside parentheses. Only one Device Marking contained in parentheses and separated by a "~" will appear on a device. If a line is indented then it is a continuation of the previous line and the two combined represent the entire Device Marking for that device.

<sup>(6)</sup> Lead finish/Ball material - Orderable Devices may have multiple material finish options. Finish options are separated by a vertical ruled line. Lead finish/Ball material values may wrap to two lines if the finish value exceeds the maximum column width.

**Important Information and Disclaimer:**The information provided on this page represents TI's knowledge and belief as of the date that it is provided. TI bases its knowledge and belief on information provided by third parties, and makes no representation or warranty as to the accuracy of such information. Efforts are underway to better integrate information from third parties. TI has taken and continues to take reasonable steps to provide representative and accurate information but may not have conducted destructive testing or chemical analysis on incoming materials and chemicals. TI and TI suppliers consider certain information to be proprietary, and thus CAS numbers and other limited information may not be available for release.

In no event shall TI's liability arising out of such information exceed the total purchase price of the TI part(s) at issue in this document sold by TI to Customer on an annual basis.

**TAPE AND REEL INFORMATION**

**QUADRANT ASSIGNMENTS FOR PIN 1 ORIENTATION IN TAPE**

\*All dimensions are nominal

Device	Package Type	Package Drawing	Pins	SPQ	Reel Diameter (mm)	Reel Width W1 (mm)	A0 (mm)	B0 (mm)	K0 (mm)	P1 (mm)	W (mm)	Pin1 Quadrant
SN74CBT3244DBQR	SSOP	DBQ	20	2500	330.0	16.4	6.5	9.0	2.1	8.0	16.0	Q1
SN74CBT3244DBR	SSOP	DB	20	2000	330.0	16.4	8.2	7.5	2.5	12.0	16.0	Q1
SN74CBT3244DGVR	TVSOP	DGV	20	2000	330.0	12.4	6.9	5.6	1.6	8.0	12.0	Q1
SN74CBT3244DWR	SOIC	DW	20	2000	330.0	24.4	10.8	13.3	2.7	12.0	24.0	Q1
SN74CBT3244PWR	TSSOP	PW	20	2000	330.0	16.4	6.95	7.1	1.6	8.0	16.0	Q1
SN74CBT3244RGYR	VQFN	RGY	20	3000	330.0	12.4	3.8	4.8	1.6	8.0	12.0	Q1

**TAPE AND REEL BOX DIMENSIONS**

\*All dimensions are nominal

Device	Package Type	Package Drawing	Pins	SPQ	Length (mm)	Width (mm)	Height (mm)
SN74CBT3244DBQR	SSOP	DBQ	20	2500	356.0	356.0	35.0
SN74CBT3244DBR	SSOP	DB	20	2000	356.0	356.0	35.0
SN74CBT3244DGVR	TVSOP	DGV	20	2000	367.0	367.0	35.0
SN74CBT3244DWR	SOIC	DW	20	2000	367.0	367.0	45.0
SN74CBT3244PWR	TSSOP	PW	20	2000	356.0	356.0	35.0
SN74CBT3244RGYR	VQFN	RGY	20	3000	367.0	367.0	35.0

**TUBE**

\*All dimensions are nominal

Device	Package Name	Package Type	Pins	SPQ	L (mm)	W (mm)	T (μm)	B (mm)
SN74CBT3244DW	DW	SOIC	20	25	507	12.83	5080	6.6
SN74CBT3244PW	PW	TSSOP	20	70	530	10.2	3600	3.5



# DB0020A



# PACKAGE OUTLINE

## SSOP - 2 mm max height

SMALL OUTLINE PACKAGE



4214851/B 08/2019

### NOTES:

1. All linear dimensions are in millimeters. Any dimensions in parenthesis are for reference only. Dimensioning and tolerancing per ASME Y14.5M.
2. This drawing is subject to change without notice.
3. This dimension does not include mold flash, protrusions, or gate burrs. Mold flash, protrusions, or gate burrs shall not exceed 0.15 mm per side.
4. This dimension does not include interlead flash. Interlead flash shall not exceed 0.25 mm per side.
5. Reference JEDEC registration MO-150.

# EXAMPLE BOARD LAYOUT

DB0020A

SSOP - 2 mm max height

SMALL OUTLINE PACKAGE



LAND PATTERN EXAMPLE  
EXPOSED METAL SHOWN  
SCALE: 10X



4214851/B 08/2019

NOTES: (continued)

6. Publication IPC-7351 may have alternate designs.
7. Solder mask tolerances between and around signal pads can vary based on board fabrication site.

# EXAMPLE STENCIL DESIGN

DB0020A

SSOP - 2 mm max height

SMALL OUTLINE PACKAGE

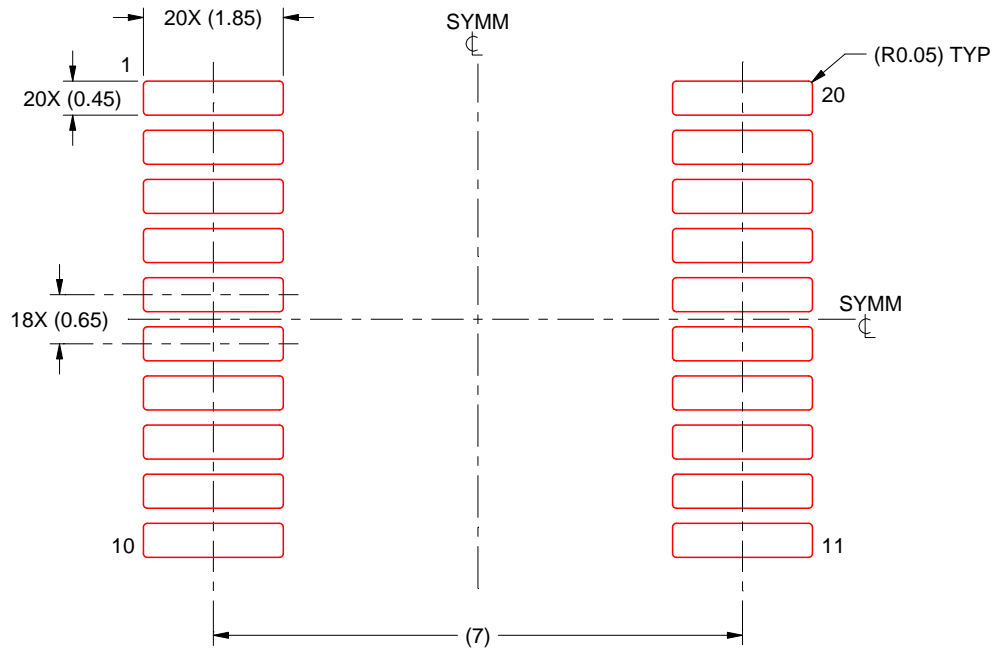

SOLDER PASTE EXAMPLE  
BASED ON 0.125 mm THICK STENCIL  
SCALE: 10X

4214851/B 08/2019

NOTES: (continued)

8. Laser cutting apertures with trapezoidal walls and rounded corners may offer better paste release. IPC-7525 may have alternate design recommendations.
9. Board assembly site may have different recommendations for stencil design.

DGV (R-PDSO-G\*\*)

PLASTIC SMALL-OUTLINE

24 PINS SHOWN



- NOTES: A. All linear dimensions are in millimeters.  
 B. This drawing is subject to change without notice.  
 C. Body dimensions do not include mold flash or protrusion, not to exceed 0,15 per side.  
 D. Falls within JEDEC: 24/48 Pins – MO-153  
 14/16/20/56 Pins – MO-194

## GENERIC PACKAGE VIEW

**RGY 20**

**VQFN - 1 mm max height**

3.5 x 4.5, 0.5 mm pitch

PLASTIC QUAD FGLATPACK - NO LEAD

This image is a representation of the package family, actual package may vary.  
Refer to the product data sheet for package details.

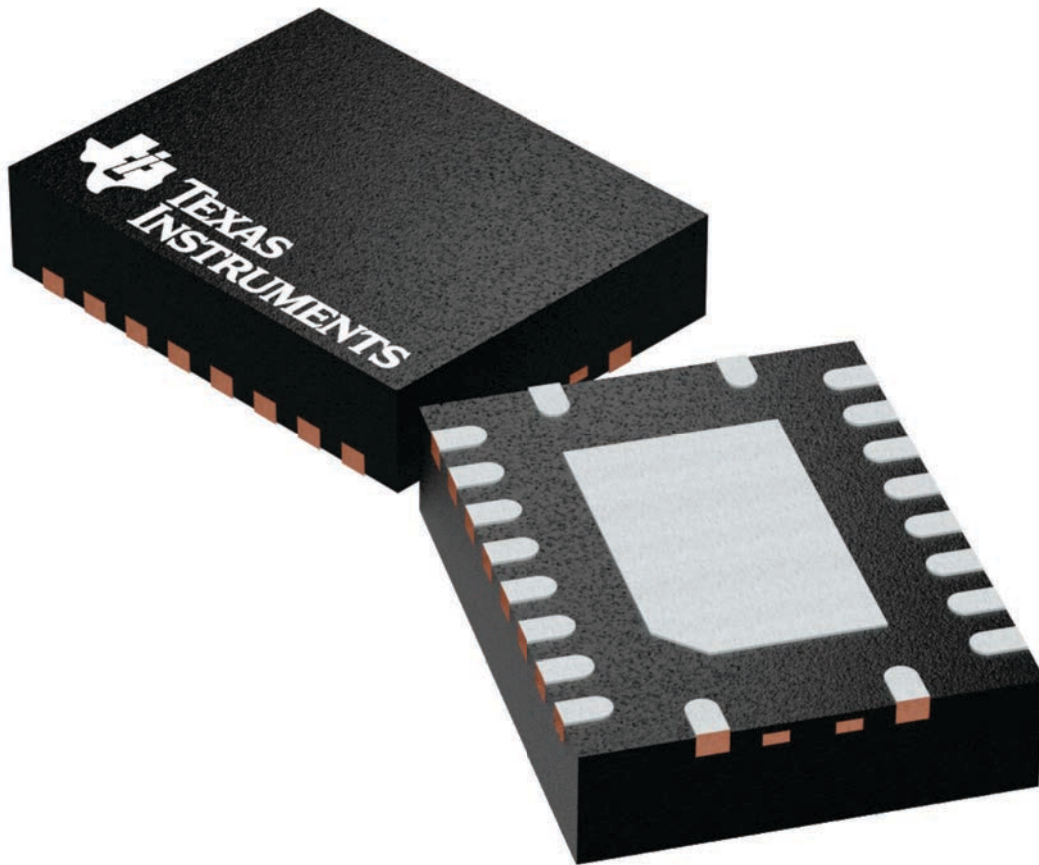

4225264/A

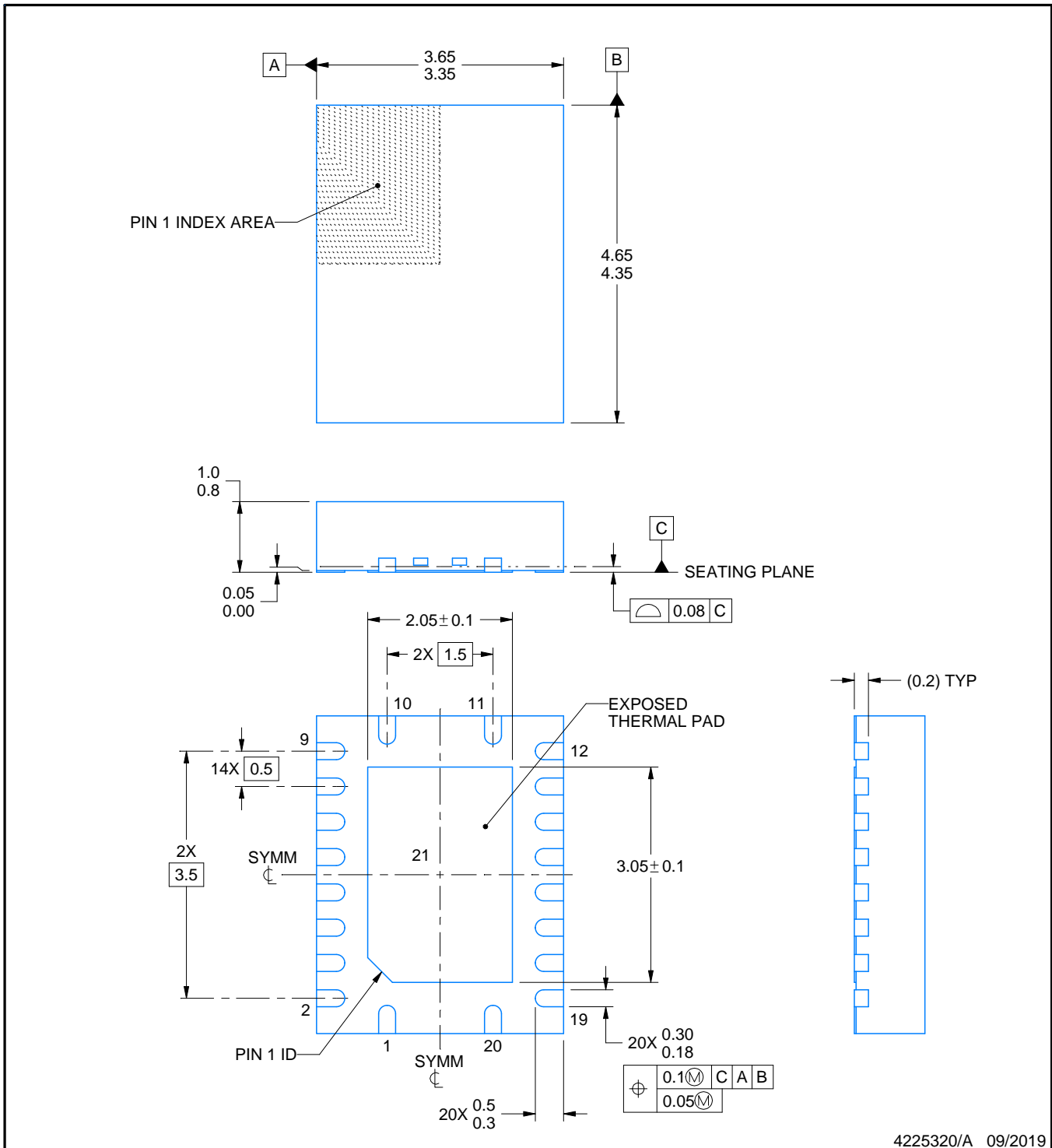
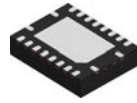

4225320/A 09/2019

NOTES:

1. All linear dimensions are in millimeters. Any dimensions in parenthesis are for reference only. Dimensioning and tolerancing per ASME Y14.5M.
2. This drawing is subject to change without notice.
3. The package thermal pad must be soldered to the printed circuit board for thermal and mechanical performance.

# EXAMPLE BOARD LAYOUT

RGY0020A

VQFN - 1 mm max height

PLASTIC QUAD FLATPACK - NO LEAD

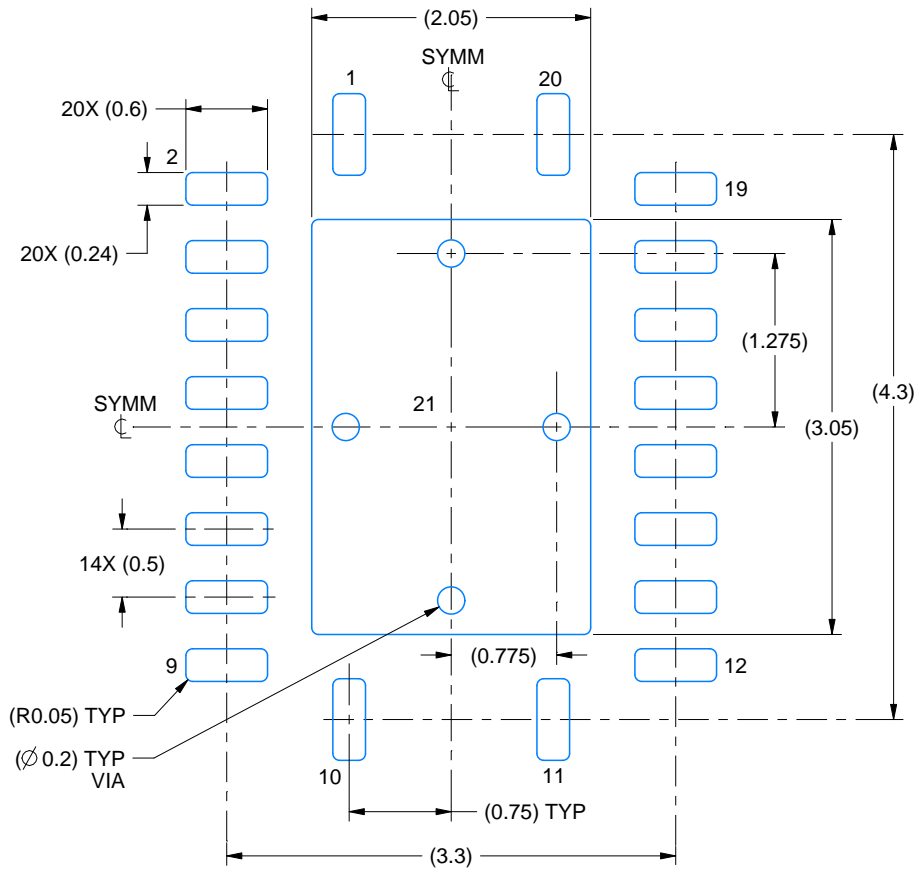

LAND PATTERN EXAMPLE  
EXPOSED METAL SHOWN  
SCALE:18X

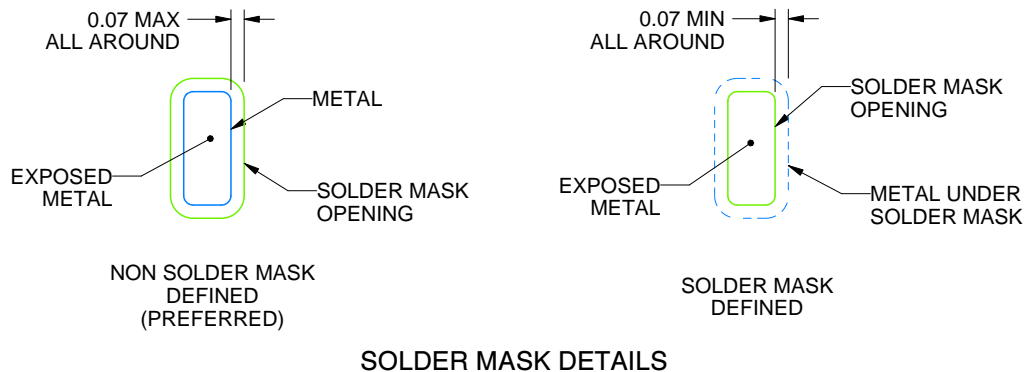

SOLDER MASK DETAILS

4225320/A 09/2019

NOTES: (continued)

- This package is designed to be soldered to a thermal pad on the board. For more information, see Texas Instruments literature number SLUA271 ([www.ti.com/lit/sluea271](http://www.ti.com/lit/sluea271)).
- Vias are optional depending on application, refer to device data sheet. If any vias are implemented, refer to their locations shown on this view. It is recommended that vias under paste be filled, plugged or tented.

# EXAMPLE STENCIL DESIGN

RGY0020A

VQFN - 1 mm max height

PLASTIC QUAD FLATPACK - NO LEAD

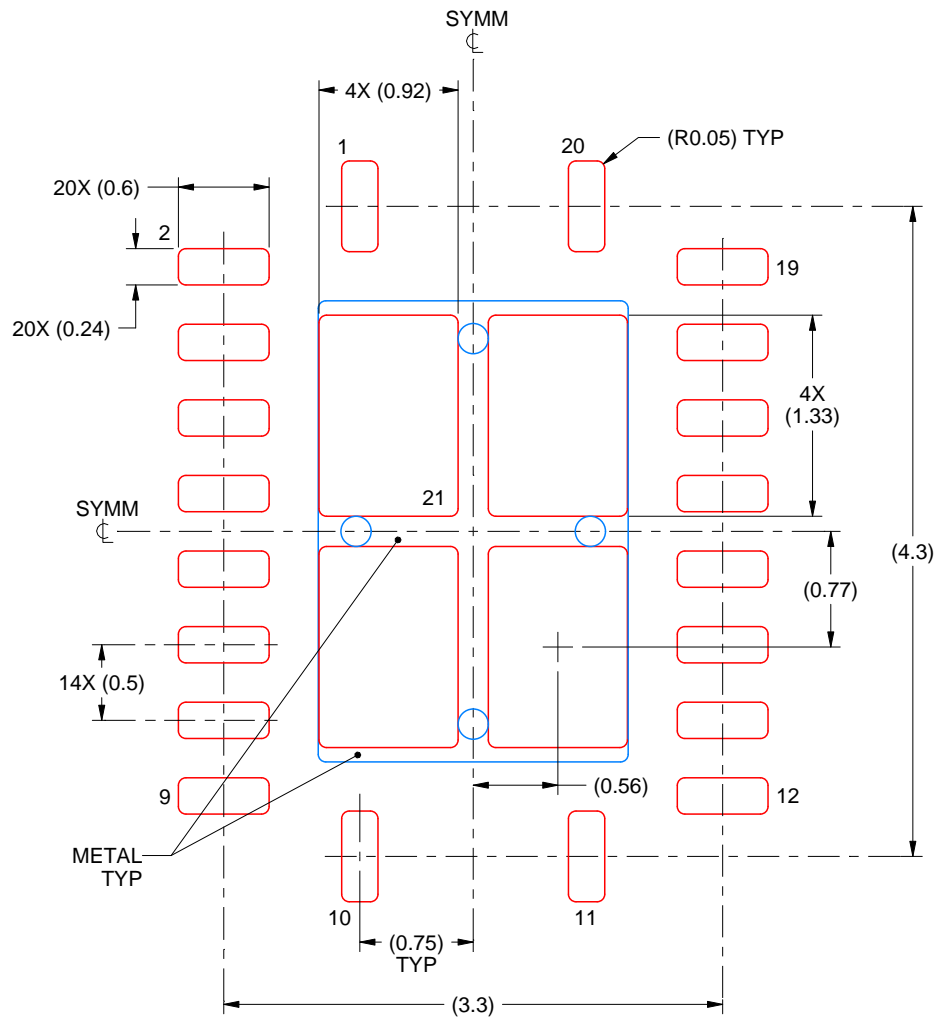

**SOLDER PASTE EXAMPLE**  
BASED ON 0.125 mm THICK STENCIL

EXPOSED PAD 21  
78% PRINTED SOLDER COVERAGE BY AREA UNDER PACKAGE  
SCALE:20X

4225320/A 09/2019

NOTES: (continued)

6. Laser cutting apertures with trapezoidal walls and rounded corners may offer better paste release. IPC-7525 may have alternate design recommendations.

# DW0020A



# PACKAGE OUTLINE

## SOIC - 2.65 mm max height

SOIC



**NOTES:**

1. All linear dimensions are in millimeters. Dimensions in parenthesis are for reference only. Dimensioning and tolerancing per ASME Y14.5M.
2. This drawing is subject to change without notice.
3. This dimension does not include mold flash, protrusions, or gate burrs. Mold flash, protrusions, or gate burrs shall not exceed 0.15 mm per side.
4. This dimension does not include interlead flash. Interlead flash shall not exceed 0.43 mm per side.
5. Reference JEDEC registration MS-013.

# EXAMPLE BOARD LAYOUT

DW0020A

SOIC - 2.65 mm max height

SOIC



LAND PATTERN EXAMPLE  
SCALE:6X



SOLDER MASK DETAILS

4220724/A 05/2016

NOTES: (continued)

- 6. Publication IPC-7351 may have alternate designs.
- 7. Solder mask tolerances between and around signal pads can vary based on board fabrication site.

# EXAMPLE STENCIL DESIGN

DW0020A

SOIC - 2.65 mm max height

SOIC



SOLDER PASTE EXAMPLE  
BASED ON 0.125 mm THICK STENCIL  
SCALE:6X

4220724/A 05/2016

NOTES: (continued)

8. Laser cutting apertures with trapezoidal walls and rounded corners may offer better paste release. IPC-7525 may have alternate design recommendations.
9. Board assembly site may have different recommendations for stencil design.

PW0020A



# PACKAGE OUTLINE

## TSSOP - 1.2 mm max height

SMALL OUTLINE PACKAGE



4220206/A 02/2017

### NOTES:

- All linear dimensions are in millimeters. Any dimensions in parenthesis are for reference only. Dimensioning and tolerancing per ASME Y14.5M.
- This drawing is subject to change without notice.
- This dimension does not include mold flash, protrusions, or gate burrs. Mold flash, protrusions, or gate burrs shall not exceed 0.15 mm per side.
- This dimension does not include interlead flash. Interlead flash shall not exceed 0.25 mm per side.
- Reference JEDEC registration MO-153.

# EXAMPLE BOARD LAYOUT

PW0020A

TSSOP - 1.2 mm max height

SMALL OUTLINE PACKAGE



LAND PATTERN EXAMPLE  
EXPOSED METAL SHOWN  
SCALE: 10X



SOLDER MASK DETAILS

4220206/A 02/2017

NOTES: (continued)

- 6. Publication IPC-7351 may have alternate designs.
- 7. Solder mask tolerances between and around signal pads can vary based on board fabrication site.

# EXAMPLE STENCIL DESIGN

PW0020A

TSSOP - 1.2 mm max height

SMALL OUTLINE PACKAGE



SOLDER PASTE EXAMPLE  
BASED ON 0.125 mm THICK STENCIL  
SCALE: 10X

4220206/A 02/2017

NOTES: (continued)

8. Laser cutting apertures with trapezoidal walls and rounded corners may offer better paste release. IPC-7525 may have alternate design recommendations.
9. Board assembly site may have different recommendations for stencil design.

PW (R-PDSO-G20)

PLASTIC SMALL OUTLINE



- NOTES:
- A. All linear dimensions are in millimeters.
  - B. This drawing is subject to change without notice.
  - C. Publication IPC-7351 is recommended for alternate design.
  - D. Laser cutting apertures with trapezoidal walls and also rounding corners will offer better paste release. Customers should contact their board assembly site for stencil design recommendations. Refer to IPC-7525 for other stencil recommendations.
  - E. Customers should contact their board fabrication site for solder mask tolerances between and around signal pads.

## IMPORTANT NOTICE AND DISCLAIMER

TI PROVIDES TECHNICAL AND RELIABILITY DATA (INCLUDING DATA SHEETS), DESIGN RESOURCES (INCLUDING REFERENCE DESIGNS), APPLICATION OR OTHER DESIGN ADVICE, WEB TOOLS, SAFETY INFORMATION, AND OTHER RESOURCES "AS IS" AND WITH ALL FAULTS, AND DISCLAIMS ALL WARRANTIES, EXPRESS AND IMPLIED, INCLUDING WITHOUT LIMITATION ANY IMPLIED WARRANTIES OF MERCHANTABILITY, FITNESS FOR A PARTICULAR PURPOSE OR NON-INFRINGEMENT OF THIRD PARTY INTELLECTUAL PROPERTY RIGHTS.

These resources are intended for skilled developers designing with TI products. You are solely responsible for (1) selecting the appropriate TI products for your application, (2) designing, validating and testing your application, and (3) ensuring your application meets applicable standards, and any other safety, security, regulatory or other requirements.

These resources are subject to change without notice. TI grants you permission to use these resources only for development of an application that uses the TI products described in the resource. Other reproduction and display of these resources is prohibited. No license is granted to any other TI intellectual property right or to any third party intellectual property right. TI disclaims responsibility for, and you will fully indemnify TI and its representatives against, any claims, damages, costs, losses, and liabilities arising out of your use of these resources.

TI's products are provided subject to [TI's Terms of Sale](#) or other applicable terms available either on [ti.com](https://www.ti.com) or provided in conjunction with such TI products. TI's provision of these resources does not expand or otherwise alter TI's applicable warranties or warranty disclaimers for TI products.

TI objects to and rejects any additional or different terms you may have proposed.

Mailing Address: Texas Instruments, Post Office Box 655303, Dallas, Texas 75265  
Copyright © 2024, Texas Instruments Incorporated

## Looking for pricing, stock, or lifecycle information?

Click below to explore more details on WIN SOURCE:

 [View SN74CBT3244DBRG4 on WIN SOURCE](#)

 [Texas Instruments](#) Information

## Optimize Your Supply Chain with WIN SOURCE Solutions

-  Global Sourcing Solution
-  Obsolete Management
-  Cost Control Management
-  Shortage Management
-  Alternative Solution
-  Excess Inventory Management