



**THE DATASHEET OF  
SN75C3222DBRG4**



# SN65C3222, SN75C3222

## 3-V TO 5.5-V MULTICHANNEL RS-232 COMPATIBLE LINE DRIVER/RECEIVER

SLLS534B – MAY 2002 – REVISED OCTOBER 2004

- Operates With 3-V to 5.5-V  $V_{CC}$  Supply
- Operates Up To 1 Mbit/s
- Low Standby Current . . . 1  $\mu$ A Typ
- External Capacitors . . .  $4 \times 0.1 \mu$ F
- Accepts 5-V Logic Input With 3.3-V Supply
- RS-232 Bus-Pin ESD Protection Exceeds  $\pm 15$  kV Using Human-Body Model (HBM)
- Applications
  - Battery-Powered Systems, PDAs, Notebooks, Laptops, Palmtop PCs, and Hand-Held Equipment

DB, DW, OR PW PACKAGE  
(TOP VIEW)

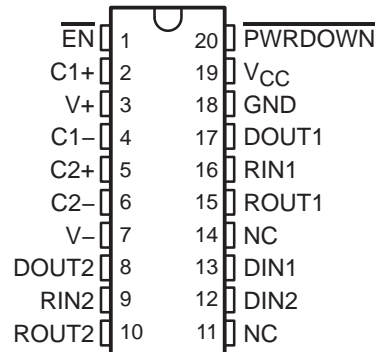

NC – No internal connection

### description/ordering information

The SN65C3222 and SN75C3222 consist of two line drivers, two line receivers, and a dual charge-pump circuit with  $\pm 15$ -kV ESD protection pin to pin (serial-port connection pins, including GND). The devices provide the electrical interface between an asynchronous communication controller and the serial-port connector. The charge pump and four small external capacitors allow operation from a single 3-V to 5.5-V supply. The devices operate at data signaling rates up to 1 Mbit/s and a driver output slew rate of 24 V/ $\mu$ s to 150 V/ $\mu$ s.

The SN65C3222 and SN75C3222 can be placed in the power-down mode by setting  $\overline{\text{PWRDOWN}}$  low, which draws only 1  $\mu$ A from the power supply. When the devices are powered down, the receivers remain active while the drivers are placed in the high-impedance state. Also, during power down, the onboard charge pump is disabled,  $V+$  is lowered to  $V_{CC}$ , and  $V-$  is raised toward GND. Receiver outputs also can be placed in the high-impedance state by setting  $\overline{\text{EN}}$  high.

### ORDERING INFORMATION

$T_A$	PACKAGE†		ORDERABLE PART NUMBER	TOP-SIDE MARKING
–0°C to 70°C	SOIC (DW)	Tube of 25	SN75C3222DW	75C3222
		Reel of 2000	SN75C3222DWR	
	SSOP (DB)	Reel of 2000	SN75C3222DBR	CA3222
	TSSOP (PW)	Tube of 70	SN75C3222PW	CA3222
Reel of 2000		SN75C3222PWR		
–40°C to 85°C	SOIC (DW)	Tube of 25	SN65C3222DW	65C3222
		Reel of 2000	SN65C3222DWR	
	SSOP (DB)	Reel of 2000	SN65C3222DBR	CB3222
	TSSOP (PW)	Tube of 70	SN65C3222PW	CB3222
Reel of 2000		SN65C3222PWR		

† Package drawings, standard packing quantities, thermal data, symbolization, and PCB design guidelines are available at [www.ti.com/sc/package](http://www.ti.com/sc/package).



Please be aware that an important notice concerning availability, standard warranty, and use in critical applications of Texas Instruments semiconductor products and disclaimers thereto appears at the end of this data sheet.

PRODUCTION DATA information is current as of publication date. Products conform to specifications per the terms of Texas Instruments standard warranty. Production processing does not necessarily include testing of all parameters.

**TEXAS  
INSTRUMENTS**

POST OFFICE BOX 655303 • DALLAS, TEXAS 75265

Copyright © 2004, Texas Instruments Incorporated

# SN65C3222, SN75C3222

## 3-V TO 5.5-V MULTICHANNEL RS-232 COMPATIBLE LINE DRIVER/RECEIVER

SLLS534B – MAY 2002 – REVISED OCTOBER 2004

### Function Tables

#### EACH DRIVER

INPUTS		OUTPUT DOUT
DIN	PWRDOWN	
X	L	Z
L	H	H
H	H	L

H = high level, L = low level, X = irrelevant,  
Z = high impedance

#### EACH RECEIVER

INPUTS		OUTPUT ROUT
RIN	$\overline{\text{EN}}$	
L	L	H
H	L	L
X	H	Z
Open	L	H

H = high level, L = low level, X = irrelevant,  
Z = high impedance (off), Open = input  
disconnected or connected driver off

### logic diagram (positive logic)

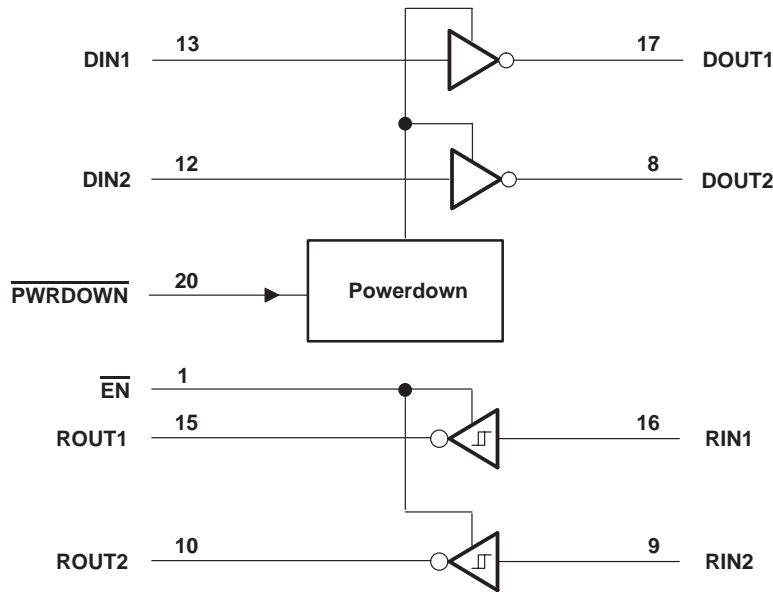

# SN65C3222, SN75C3222

## 3-V TO 5.5-V MULTICHANNEL RS-232 COMPATIBLE LINE DRIVER/RECEIVER

SLLS534B – MAY 2002 – REVISED OCTOBER 2004

### absolute maximum ratings over operating free-air temperature range (unless otherwise noted)†

Supply voltage range, $V_{CC}$ (see Note 1)	–0.3 V to 6 V
Positive output supply voltage range, $V+$ (see Note 1)	–0.3 V to 7 V
Negative output supply voltage range, $V-$ (see Note 1)	0.3 V to –7 V
Supply voltage difference, $V+ - V-$ (see Note 1)	13 V
Input voltage range, $V_I$ : Drivers, $\overline{EN}$ , $\overline{PWRDOWN}$	–0.3 V to 6 V
Receivers	–25 V to 25 V
Output voltage range, $V_O$ : Drivers	–13.2 V to 13.2 V
Receivers	–0.3 V to $V_{CC} + 0.3$ V
Package thermal impedance, $\theta_{JA}$ (see Notes 2 and 3): DB package	70°C/W
DW package	58°C/W
PW package	83°C/W
Operating virtual junction temperature, $T_J$	150°C
Storage temperature range, $T_{stg}$	–65°C to 150°C

† Stresses beyond those listed under “absolute maximum ratings” may cause permanent damage to the device. These are stress ratings only, and functional operation of the device at these or any other conditions beyond those indicated under “recommended operating conditions” is not implied. Exposure to absolute-maximum-rated conditions for extended periods may affect device reliability.

- NOTES:
1. All voltages are with respect to network GND.
  2. Maximum power dissipation is a function of  $T_J(\max)$ ,  $\theta_{JA}$ , and  $T_A$ . The maximum allowable power dissipation at any allowable ambient temperature is  $P_D = (T_J(\max) - T_A)/\theta_{JA}$ . Operating at the absolute maximum  $T_J$  of 150°C can affect reliability.
  3. The package thermal impedance is calculated in accordance with JESD 51-7.

### recommended operating conditions (see Note 4 and Figure 5)

		MIN	NOM	MAX	UNIT
Supply voltage	$V_{CC} = 3.3$ V	3	3.3	3.6	V
	$V_{CC} = 5$ V	4.5	5	5.5	
$V_{IH}$	Driver and control high-level input voltage DIN, $\overline{EN}$ , $\overline{PWRDOWN}$	$V_{CC} = 3.3$ V 2			V
		$V_{CC} = 5$ V 2.4			
$V_{IL}$	Driver and control low-level input voltage DIN, $\overline{EN}$ , $\overline{PWRDOWN}$			0.8	V
$V_I$	Driver and control input voltage DIN, $\overline{EN}$ , $\overline{PWRDOWN}$	0		5.5	V
$V_I$	Receiver input voltage	–25		25	V
$T_A$	Operating free-air temperature SN65C3222	–40		85	°C
	SN75C3222	0		70	

NOTE 4: Test conditions are C1–C4 = 0.1  $\mu$ F at  $V_{CC} = 3.3$  V  $\pm$  0.3 V; C1 = 0.047  $\mu$ F, C2–C4 = 0.33  $\mu$ F at  $V_{CC} = 5$  V  $\pm$  0.5 V.

### electrical characteristics over recommended ranges of supply voltage and operating free-air temperature (unless otherwise noted) (see Note 4 and Figure 5)

PARAMETER		TEST CONDITIONS		MIN	TYP‡	MAX	UNIT
$I_I$	Input leakage current ( $\overline{EN}$ , $\overline{PWRDOWN}$ )			$\pm$ 0.01	$\pm$ 1		$\mu$ A
$I_{CC}$	Supply current	No load, $\overline{PWRDOWN}$ at $V_{CC}$		0.3	1		mA
	Supply current (powered off)	No load, $\overline{PWRDOWN}$ at GND		1	10		$\mu$ A

‡ All typical values are at  $V_{CC} = 3.3$  V or  $V_{CC} = 5$  V, and  $T_A = 25^\circ$ C.

NOTE 4: Test conditions are C1–C4 = 0.1  $\mu$ F at  $V_{CC} = 3.3$  V  $\pm$  0.3 V; C1 = 0.047  $\mu$ F, C2–C4 = 0.33  $\mu$ F at  $V_{CC} = 5$  V  $\pm$  0.5 V.



# SN65C3222, SN75C3222

## 3-V TO 5.5-V MULTICHANNEL RS-232 COMPATIBLE LINE DRIVER/RECEIVER

SLLS534B – MAY 2002 – REVISED OCTOBER 2004

### DRIVER SECTION

electrical characteristics over recommended ranges of supply voltage and operating free-air temperature (unless otherwise noted) (see Note 4 and Figure 5)

PARAMETER	TEST CONDITIONS	MIN	TYP†	MAX	UNIT
V <sub>OH</sub> High-level output voltage	DOUT at R <sub>L</sub> = 3 kΩ to GND, DIN = GND	5	5.4		V
V <sub>OL</sub> Low-level output voltage	DOUT at R <sub>L</sub> = 3 kΩ to GND, DIN = V <sub>CC</sub>	-5	-5.4		V
I <sub>IH</sub> High-level input current	V <sub>I</sub> = V <sub>CC</sub>		±0.01	±1	μA
I <sub>IL</sub> Low-level input current	V <sub>I</sub> at GND		±0.01	±1	μA
I <sub>OS</sub> Short-circuit output current‡	V <sub>CC</sub> = 3.6 V, V <sub>O</sub> = 0 V		±35	±60	mA
	V <sub>CC</sub> = 5.5 V, V <sub>O</sub> = 0 V		±35	±90	
r <sub>o</sub> Output resistance	V <sub>CC</sub> , V+, and V- = 0 V, V <sub>O</sub> = ±2 V	300	10M		Ω
I <sub>off</sub> Output leakage current	PWRDOWN = GND	V <sub>O</sub> = ±12 V, V <sub>CC</sub> = 3 V to 3.6 V		±25	μA
		V <sub>O</sub> = ±10 V, V <sub>CC</sub> = 4.5 V to 5.5 V		±25	

† All typical values are at V<sub>CC</sub> = 3.3 V or V<sub>CC</sub> = 5 V, and T<sub>A</sub> = 25°C.

‡ Short-circuit durations should be controlled to prevent exceeding the device absolute power-dissipation ratings, and not more than one output should be shorted at a time.

NOTE 4: Test conditions are C1–C4 = 0.1 μF at V<sub>CC</sub> = 3.3 V ± 0.3 V; C1 = 0.047 μF, C2–C4 = 0.33 μF at V<sub>CC</sub> = 5 V ± 0.5 V.

switching characteristics over recommended ranges of supply voltage and operating free-air temperature (unless otherwise noted) (see Note 4 and Figure 4)

PARAMETER	TEST CONDITIONS	MIN	TYP†	MAX	UNIT	
Maximum data rate (see Figure 1)	R <sub>L</sub> = 3 kΩ, One DOOUT switching	C <sub>L</sub> = 1000 pF		250	kbit/s	
		C <sub>L</sub> = 250 pF, V <sub>CC</sub> = 3 V to 4.5 V	1000			
		C <sub>L</sub> = 1000 pF, V <sub>CC</sub> = 4.5 V to 5.5 V	1000			
t <sub>sk(p)</sub> Pulse skew§	C <sub>L</sub> = 150 pF to 2500 pF	R <sub>L</sub> = 3 kΩ to 7 kΩ, See Figure 2		300	ns	
SR(tr) Slew rate, transition region (see Figure 1)	R <sub>L</sub> = 3 kΩ to 7 kΩ, V <sub>CC</sub> = 3.3 V	C <sub>L</sub> = 150 pF to 1000 pF		18	150	V/μs

† All typical values are at V<sub>CC</sub> = 3.3 V or V<sub>CC</sub> = 5 V, and T<sub>A</sub> = 25°C.

§ Pulse skew is defined as |t<sub>PLH</sub> - t<sub>PHL</sub>| of each channel of the same device.

NOTE 4: Test conditions are C1–C4 = 0.1 μF at V<sub>CC</sub> = 3.3 V ± 0.3 V; C1 = 0.047 μF, C2–C4 = 0.33 μF at V<sub>CC</sub> = 5 V ± 0.5 V.



# SN65C3222, SN75C3222

## 3-V TO 5.5-V MULTICHANNEL RS-232 COMPATIBLE LINE DRIVER/RECEIVER

SLLS534B – MAY 2002 – REVISED OCTOBER 2004

### RECEIVER SECTION

**electrical characteristics over recommended ranges of supply voltage and operating free-air temperature (unless otherwise noted) (see Note 4 and Figure 5)**

PARAMETER		TEST CONDITIONS	MIN	TYP†	MAX	UNIT
V <sub>OH</sub>	High-level output voltage	I <sub>OH</sub> = -1 mA	V <sub>CC</sub> - 0.6 V	V <sub>CC</sub> - 0.1 V		V
V <sub>OL</sub>	Low-level output voltage	I <sub>OL</sub> = 1.6 mA			0.4	V
V <sub>IT+</sub>	Positive-going input threshold voltage	V <sub>CC</sub> = 3.3 V		1.5	2.4	V
		V <sub>CC</sub> = 5 V		1.8	2.4	
V <sub>IT-</sub>	Negative-going input threshold voltage	V <sub>CC</sub> = 3.3 V	0.6	1.2		V
		V <sub>CC</sub> = 5 V	0.8	1.5		
V <sub>hys</sub>	Input hysteresis (V <sub>IT+</sub> - V <sub>IT-</sub> )			0.3		V
I <sub>off</sub>	Output leakage current	$\overline{\text{EN}} = V_{\text{CC}}$		±0.05	±10	μA
r <sub>i</sub>	Input resistance	V <sub>I</sub> = ±3 V to ±25 V	3	5	7	kΩ

† All typical values are at V<sub>CC</sub> = 3.3 V or V<sub>CC</sub> = 5 V, and T<sub>A</sub> = 25°C.

NOTE 4: Test conditions are C1–C4 = 0.1 μF at V<sub>CC</sub> = 3.3 V ± 0.3 V; C1 = 0.047 μF, C2–C4 = 0.33 μF at V<sub>CC</sub> = 5 V ± 0.5 V.

**switching characteristics over recommended ranges of supply voltage and operating free-air temperature (unless otherwise noted) (see Note 4)**

PARAMETER		TEST CONDITIONS	MIN	TYP†	MAX	UNIT
t <sub>PLH</sub>	Propagation delay time, low- to high-level output	C <sub>L</sub> = 150 pF, See Figure 3		300		ns
t <sub>PHL</sub>	Propagation delay time, high- to low-level output	C <sub>L</sub> = 150 pF, See Figure 3		300		ns
t <sub>en</sub>	Output enable time	C <sub>L</sub> = 150 pF, R <sub>L</sub> = 3 kΩ, See Figure 4		200		ns
t <sub>dis</sub>	Output disable time	C <sub>L</sub> = 150 pF, R <sub>L</sub> = 3 kΩ, See Figure 4		200		ns
t <sub>sk(p)</sub>	Pulse skew‡	See Figure 3		300		ns

† All typical values are at V<sub>CC</sub> = 3.3 V or V<sub>CC</sub> = 5 V, and T<sub>A</sub> = 25°C.

‡ Pulse skew is defined as |t<sub>PLH</sub> - t<sub>PHL</sub>| of each channel of the same device.

NOTE 4: Test conditions are C1–C4 = 0.1 μF at V<sub>CC</sub> = 3.3 V ± 0.3 V; C1 = 0.047 μF, C2–C4 = 0.33 μF at V<sub>CC</sub> = 5 V ± 0.5 V.



# SN65C3222, SN75C3222

## 3-V TO 5.5-V MULTICHANNEL RS-232 COMPATIBLE LINE DRIVER/RECEIVER

SLLS534B – MAY 2002 – REVISED OCTOBER 2004

### PARAMETER MEASUREMENT INFORMATION

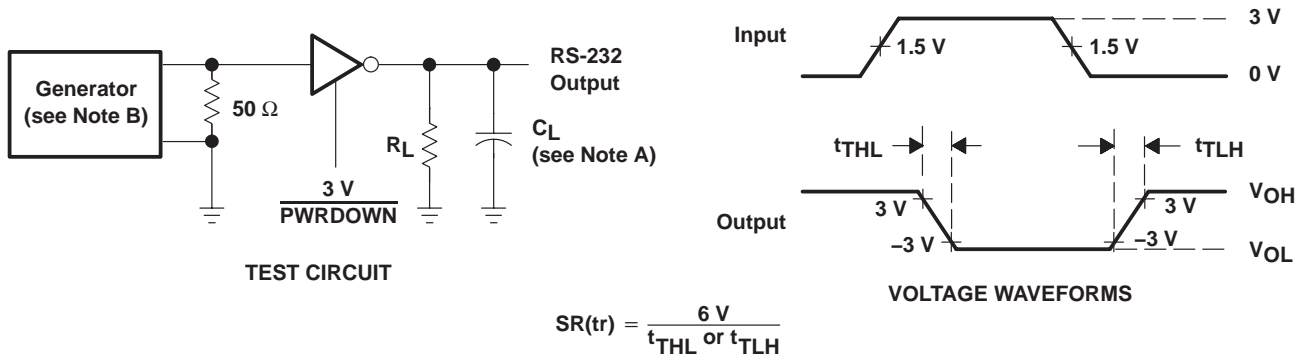

NOTES: A.  $C_L$  includes probe and jig capacitance.  
 B. The pulse generator has the following characteristics: PRR = 250 kbit/s,  $Z_O = 50\ \Omega$ , 50% duty cycle,  $t_r \leq 10\text{ ns}$ ,  $t_f \leq 10\text{ ns}$ .

Figure 1. Driver Slew Rate

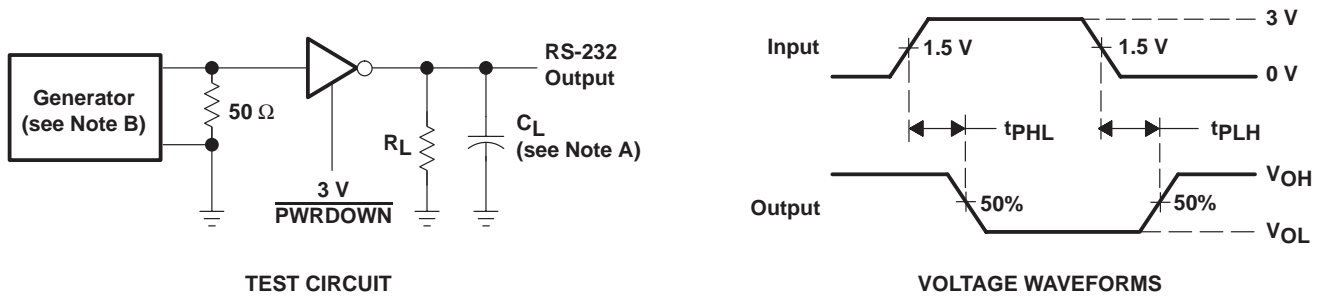

NOTES: A.  $C_L$  includes probe and jig capacitance.  
 B. The pulse generator has the following characteristics: PRR = 250 kbit/s,  $Z_O = 50\ \Omega$ , 50% duty cycle,  $t_r \leq 10\text{ ns}$ ,  $t_f \leq 10\text{ ns}$ .

Figure 2. Driver Pulse Skew

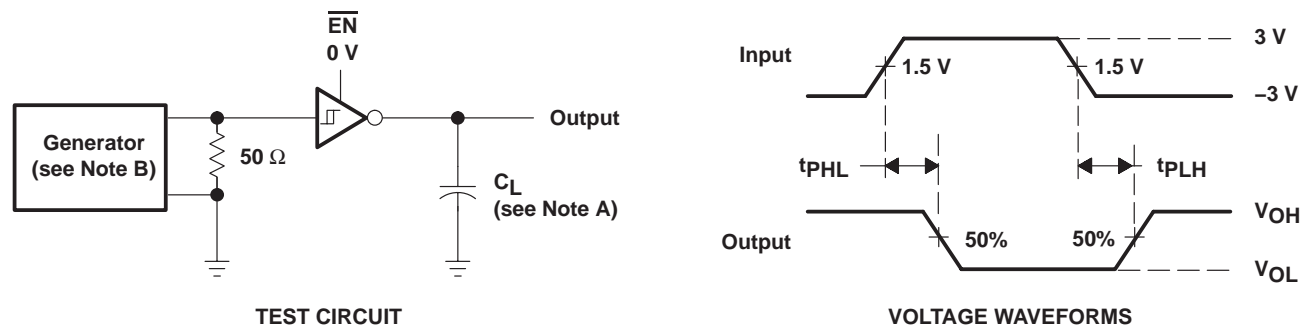

NOTES: A.  $C_L$  includes probe and jig capacitance.  
 B. The pulse generator has the following characteristics:  $Z_O = 50\ \Omega$ , 50% duty cycle,  $t_r \leq 10\text{ ns}$ ,  $t_f \leq 10\text{ ns}$ .

Figure 3. Receiver Propagation-Delay Times

**PARAMETER MEASUREMENT INFORMATION**

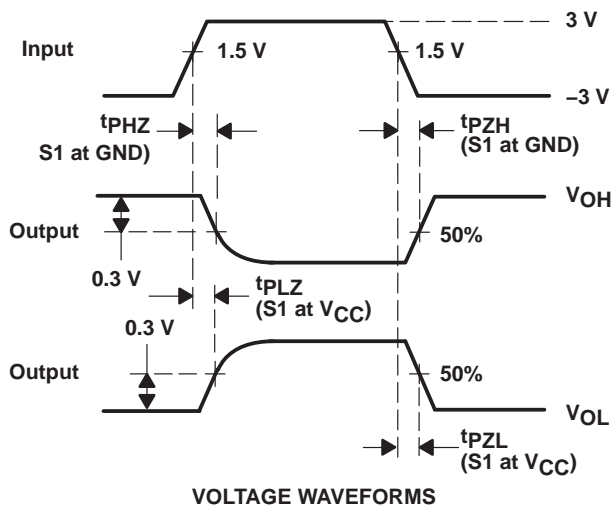
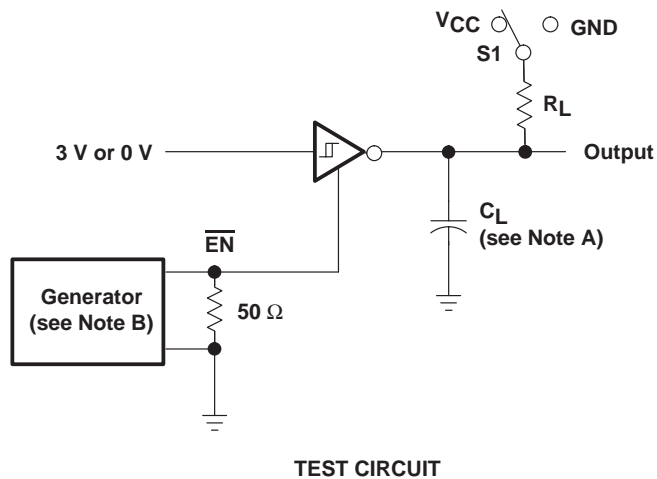

- NOTES: A.  $C_L$  includes probe and jig capacitance.  
 B. The pulse generator has the following characteristics:  $Z_O = 50 \Omega$ , 50% duty cycle,  $t_r \leq 10$  ns,  $t_f \leq 10$  ns.

**Figure 4. Receiver Enable and Disable Times**

# SN65C3222, SN75C3222 3-V TO 5.5-V MULTICHANNEL RS-232 COMPATIBLE LINE DRIVER/RECEIVER

SLLS534B – MAY 2002 – REVISED OCTOBER 2004

## APPLICATION INFORMATION

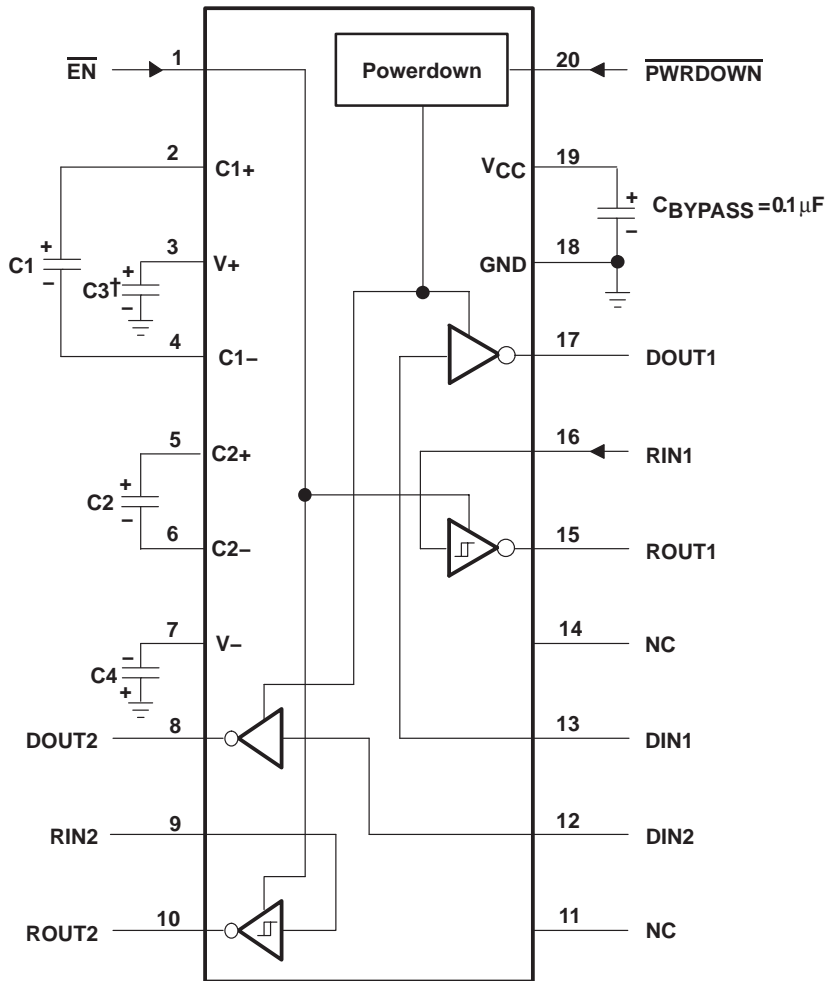

† C3 can be connected to V<sub>CC</sub> or GND.  
 NOTES: A. Resistor values shown are nominal.  
 B. NC – No internal connection

### V<sub>CC</sub> vs CAPACITOR VALUES

V <sub>CC</sub>	C1	C2, C3, and C4
3.3 V ± 0.3 V	0.1 μF	0.1 μF
5 V ± 0.5 V	0.047 μF	0.33 μF
3 V to 5.5 V	0.1 μF	0.47 μF

Figure 5. Typical Operating Circuit and Capacitor Values

**PACKAGING INFORMATION**

Orderable Device	Status (1)	Package Type	Package Drawing	Pins	Package Qty	Eco Plan (2)	Lead finish/ Ball material (6)	MSL Peak Temp (3)	Op Temp (°C)	Device Marking (4/5)	Samples
SN65C3222DBR	ACTIVE	SSOP	DB	20	2000	RoHS & Green	NIPDAU	Level-1-260C-UNLIM	-40 to 85	CB3222	<a href="#">Samples</a>
SN65C3222DWR	ACTIVE	SOIC	DW	20	2000	RoHS & Green	NIPDAU	Level-1-260C-UNLIM	-40 to 85	65C3222	<a href="#">Samples</a>
SN75C3222DW	ACTIVE	SOIC	DW	20	25	RoHS & Green	NIPDAU	Level-1-260C-UNLIM	0 to 70	75C3222	<a href="#">Samples</a>
SN75C3222DWR	ACTIVE	SOIC	DW	20	2000	RoHS & Green	NIPDAU	Level-1-260C-UNLIM	0 to 70	75C3222	<a href="#">Samples</a>

(1) The marketing status values are defined as follows:

**ACTIVE:** Product device recommended for new designs.

**LIFEBUY:** TI has announced that the device will be discontinued, and a lifetime-buy period is in effect.

**NRND:** Not recommended for new designs. Device is in production to support existing customers, but TI does not recommend using this part in a new design.

**PREVIEW:** Device has been announced but is not in production. Samples may or may not be available.

**OBSELETE:** TI has discontinued the production of the device.

(2) **RoHS:** TI defines "RoHS" to mean semiconductor products that are compliant with the current EU RoHS requirements for all 10 RoHS substances, including the requirement that RoHS substance do not exceed 0.1% by weight in homogeneous materials. Where designed to be soldered at high temperatures, "RoHS" products are suitable for use in specified lead-free processes. TI may reference these types of products as "Pb-Free".

**RoHS Exempt:** TI defines "RoHS Exempt" to mean products that contain lead but are compliant with EU RoHS pursuant to a specific EU RoHS exemption.

**Green:** TI defines "Green" to mean the content of Chlorine (Cl) and Bromine (Br) based flame retardants meet JS709B low halogen requirements of <=1000ppm threshold. Antimony trioxide based flame retardants must also meet the <=1000ppm threshold requirement.

(3) MSL, Peak Temp. - The Moisture Sensitivity Level rating according to the JEDEC industry standard classifications, and peak solder temperature.

(4) There may be additional marking, which relates to the logo, the lot trace code information, or the environmental category on the device.

(5) Multiple Device Markings will be inside parentheses. Only one Device Marking contained in parentheses and separated by a "-" will appear on a device. If a line is indented then it is a continuation of the previous line and the two combined represent the entire Device Marking for that device.

(6) Lead finish/Ball material - Orderable Devices may have multiple material finish options. Finish options are separated by a vertical ruled line. Lead finish/Ball material values may wrap to two lines if the finish value exceeds the maximum column width.

**Important Information and Disclaimer:**The information provided on this page represents TI's knowledge and belief as of the date that it is provided. TI bases its knowledge and belief on information provided by third parties, and makes no representation or warranty as to the accuracy of such information. Efforts are underway to better integrate information from third parties. TI has taken and

continues to take reasonable steps to provide representative and accurate information but may not have conducted destructive testing or chemical analysis on incoming materials and chemicals. TI and TI suppliers consider certain information to be proprietary, and thus CAS numbers and other limited information may not be available for release.

In no event shall TI's liability arising out of such information exceed the total purchase price of the TI part(s) at issue in this document sold by TI to Customer on an annual basis.

## TAPE AND REEL INFORMATION



### QUADRANT ASSIGNMENTS FOR PIN 1 ORIENTATION IN TAPE



\*All dimensions are nominal

Device	Package Type	Package Drawing	Pins	SPQ	Reel Diameter (mm)	Reel Width W1 (mm)	A0 (mm)	B0 (mm)	K0 (mm)	P1 (mm)	W (mm)	Pin1 Quadrant
SN65C3222DBR	SSOP	DB	20	2000	330.0	16.4	8.2	7.5	2.5	12.0	16.0	Q1
SN65C3222DWR	SOIC	DW	20	2000	330.0	24.4	10.8	13.3	2.7	12.0	24.0	Q1
SN75C3222DWR	SOIC	DW	20	2000	330.0	24.4	10.8	13.3	2.7	12.0	24.0	Q1

**TAPE AND REEL BOX DIMENSIONS**

\*All dimensions are nominal

Device	Package Type	Package Drawing	Pins	SPQ	Length (mm)	Width (mm)	Height (mm)
SN65C3222DBR	SSOP	DB	20	2000	356.0	356.0	35.0
SN65C3222DWR	SOIC	DW	20	2000	367.0	367.0	45.0
SN75C3222DWR	SOIC	DW	20	2000	367.0	367.0	45.0

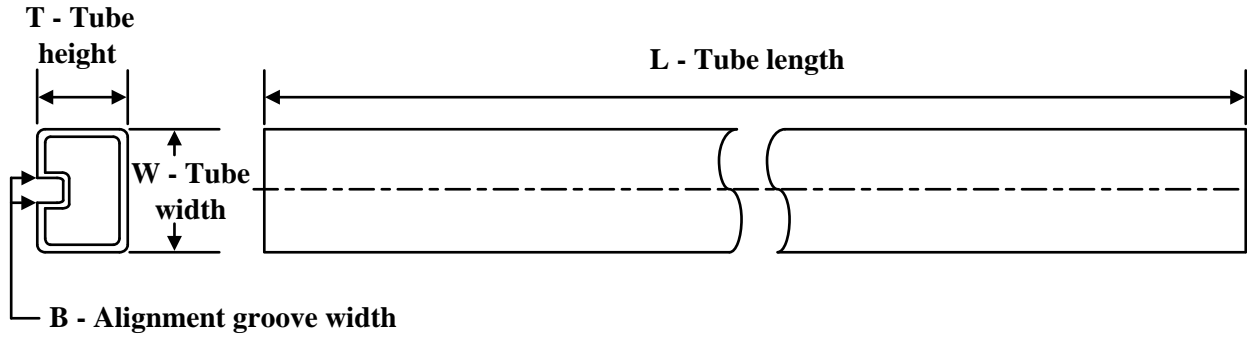
**TUBE**

\*All dimensions are nominal

Device	Package Name	Package Type	Pins	SPQ	L (mm)	W (mm)	T (μm)	B (mm)
SN75C3222DW	DW	SOIC	20	25	507	12.83	5080	6.6

# DB0020A



# PACKAGE OUTLINE

## SSOP - 2 mm max height

SMALL OUTLINE PACKAGE



### NOTES:

1. All linear dimensions are in millimeters. Any dimensions in parenthesis are for reference only. Dimensioning and tolerancing per ASME Y14.5M.
2. This drawing is subject to change without notice.
3. This dimension does not include mold flash, protrusions, or gate burrs. Mold flash, protrusions, or gate burrs shall not exceed 0.15 mm per side.
4. This dimension does not include interlead flash. Interlead flash shall not exceed 0.25 mm per side.
5. Reference JEDEC registration MO-150.

# EXAMPLE BOARD LAYOUT

DB0020A

SSOP - 2 mm max height

SMALL OUTLINE PACKAGE



LAND PATTERN EXAMPLE  
EXPOSED METAL SHOWN  
SCALE: 10X



4214851/B 08/2019

NOTES: (continued)

- 6. Publication IPC-7351 may have alternate designs.
- 7. Solder mask tolerances between and around signal pads can vary based on board fabrication site.

# EXAMPLE STENCIL DESIGN

DB0020A

SSOP - 2 mm max height

SMALL OUTLINE PACKAGE

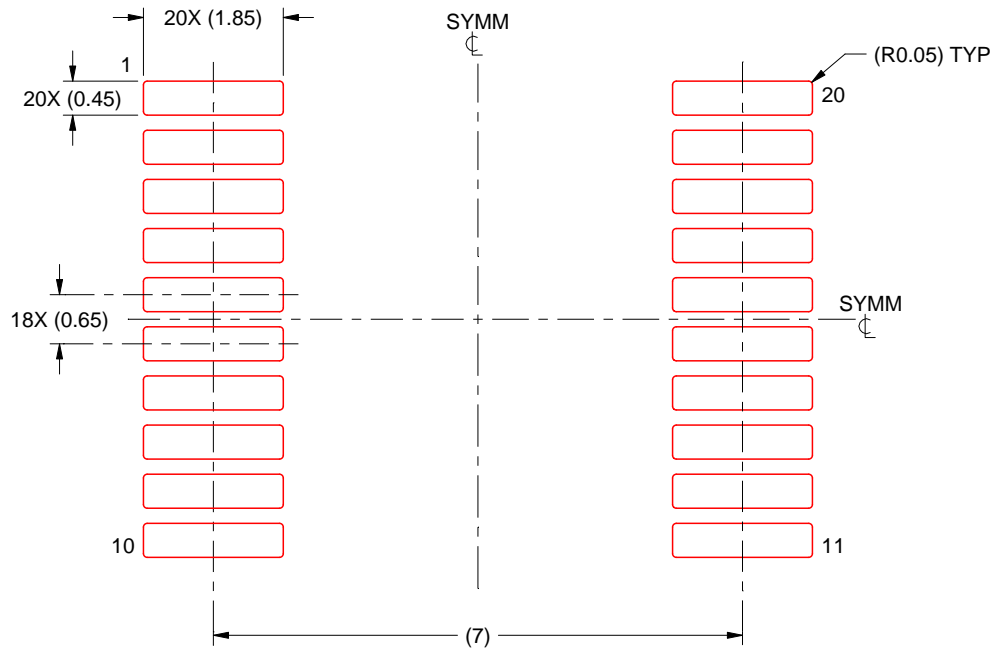

SOLDER PASTE EXAMPLE  
BASED ON 0.125 mm THICK STENCIL  
SCALE: 10X

4214851/B 08/2019

NOTES: (continued)

8. Laser cutting apertures with trapezoidal walls and rounded corners may offer better paste release. IPC-7525 may have alternate design recommendations.
9. Board assembly site may have different recommendations for stencil design.

# DW0020A



# PACKAGE OUTLINE

## SOIC - 2.65 mm max height

SOIC



**NOTES:**

1. All linear dimensions are in millimeters. Dimensions in parenthesis are for reference only. Dimensioning and tolerancing per ASME Y14.5M.
2. This drawing is subject to change without notice.
3. This dimension does not include mold flash, protrusions, or gate burrs. Mold flash, protrusions, or gate burrs shall not exceed 0.15 mm per side.
4. This dimension does not include interlead flash. Interlead flash shall not exceed 0.43 mm per side.
5. Reference JEDEC registration MS-013.

# EXAMPLE BOARD LAYOUT

DW0020A

SOIC - 2.65 mm max height

SOIC



LAND PATTERN EXAMPLE  
SCALE:6X

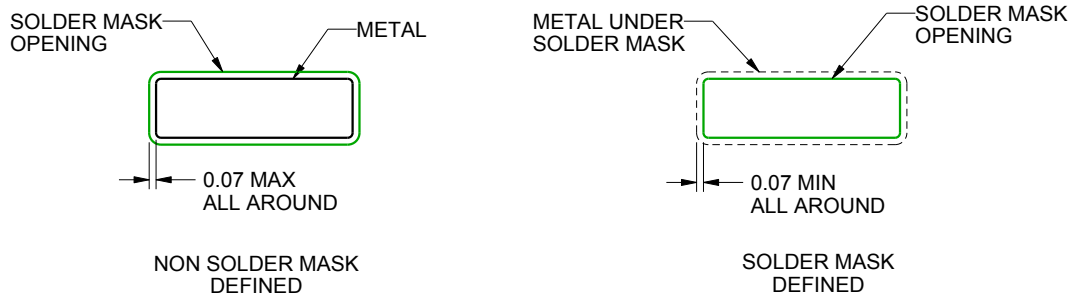

SOLDER MASK DETAILS

4220724/A 05/2016

NOTES: (continued)

- 6. Publication IPC-7351 may have alternate designs.
- 7. Solder mask tolerances between and around signal pads can vary based on board fabrication site.

# EXAMPLE STENCIL DESIGN

DW0020A

SOIC - 2.65 mm max height

SOIC



SOLDER PASTE EXAMPLE  
BASED ON 0.125 mm THICK STENCIL  
SCALE:6X

4220724/A 05/2016

NOTES: (continued)

- 8. Laser cutting apertures with trapezoidal walls and rounded corners may offer better paste release. IPC-7525 may have alternate design recommendations.
- 9. Board assembly site may have different recommendations for stencil design.

## IMPORTANT NOTICE AND DISCLAIMER

TI PROVIDES TECHNICAL AND RELIABILITY DATA (INCLUDING DATA SHEETS), DESIGN RESOURCES (INCLUDING REFERENCE DESIGNS), APPLICATION OR OTHER DESIGN ADVICE, WEB TOOLS, SAFETY INFORMATION, AND OTHER RESOURCES "AS IS" AND WITH ALL FAULTS, AND DISCLAIMS ALL WARRANTIES, EXPRESS AND IMPLIED, INCLUDING WITHOUT LIMITATION ANY IMPLIED WARRANTIES OF MERCHANTABILITY, FITNESS FOR A PARTICULAR PURPOSE OR NON-INFRINGEMENT OF THIRD PARTY INTELLECTUAL PROPERTY RIGHTS.

These resources are intended for skilled developers designing with TI products. You are solely responsible for (1) selecting the appropriate TI products for your application, (2) designing, validating and testing your application, and (3) ensuring your application meets applicable standards, and any other safety, security, regulatory or other requirements.

These resources are subject to change without notice. TI grants you permission to use these resources only for development of an application that uses the TI products described in the resource. Other reproduction and display of these resources is prohibited. No license is granted to any other TI intellectual property right or to any third party intellectual property right. TI disclaims responsibility for, and you will fully indemnify TI and its representatives against, any claims, damages, costs, losses, and liabilities arising out of your use of these resources.

TI's products are provided subject to [TI's Terms of Sale](#) or other applicable terms available either on [ti.com](https://www.ti.com) or provided in conjunction with such TI products. TI's provision of these resources does not expand or otherwise alter TI's applicable warranties or warranty disclaimers for TI products.

TI objects to and rejects any additional or different terms you may have proposed.

Mailing Address: Texas Instruments, Post Office Box 655303, Dallas, Texas 75265  
Copyright © 2024, Texas Instruments Incorporated

## Looking for pricing, stock, or lifecycle information?

Click below to explore more details on WIN SOURCE:

 [View SN75C3222DBRG4 on WIN SOURCE](#)

 [Texas Instruments](#) Information

## Optimize Your Supply Chain with WIN SOURCE Solutions

-  Global Sourcing Solution
-  Obsolete Management
-  Cost Control Management
-  Shortage Management
-  Alternative Solution
-  Excess Inventory Management