



THE DATASHEET OF ESP4836



ECLIPSE SERIES

BUL10120

REV. H

ASSEMBLY INSTRUCTIONS FOR SWING PANEL AND SWING FRAME

PARTS LIST		
PART #	QTY.	DESCRIPTION
1	1	SWING PANEL/FRAME
2	1	VERTICAL RAIL LOCK SIDE
3	1	VERTICAL RAIL HINGE SIDE
4	2	MOUNTING BRACKET (1)
5	2	MOUNTING BRACKET (2)
6	2-4	HINGE PIN
7	2-4	RUBBER PIN CAP
8	8	1/4-20 BUTTON HEAD SCREW
9	8	SEALING WASHER
10	4	1/4-20 CAGE NUT
11	4	1/4-20 SCREW
12	1	FINGER PULL
13	2	1/4 TURN LATCH

1. Drill holes for mounting brackets. (Fig. 1)

- Place mounting bracket on top left corner of enclosure. Mark two holes.
- Place mounting bracket on bottom right corner of enclosure. Mark two holes.
- Place mounting bracket on bottom left corner of enclosure. Mark two holes.
- Place mounting bracket on top right corner of enclosure. Mark two holes.
- Drill marked holes with 0.281" drill bit.

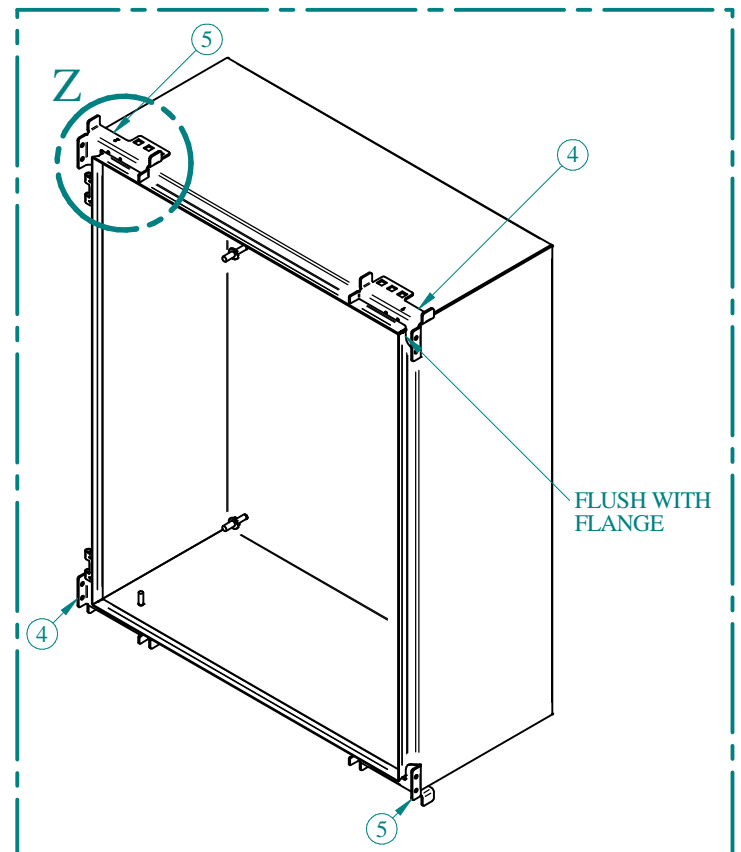
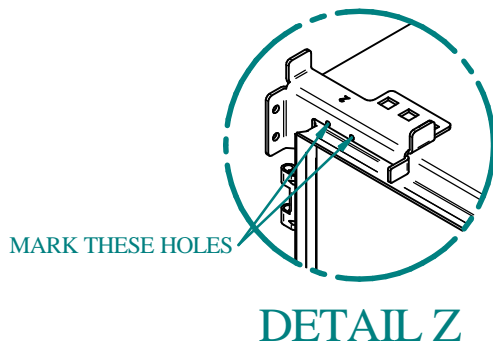

FIG. 1

TOOL BOX	3/8, 7/16" Socket Wrench	3/8 or 7/16 Open Wrench	Centre Punch	Drill, use .281(7.1mm) BIT	5/32 ALLEN KEY

HAMMOND MANUFACTURING™
www.hammondmfg.com

ECLIPSE SERIES

BUL10120

REV. H

ASSEMBLY INSTRUCTIONS FOR SWING PANEL AND SWING FRAME

2. Pre-assemble mounting brackets. (Fig. 2)

- a) Insert cage nut in square cut out of mounting bracket.
 (Review table for desired spacing)
 Shortest distance between swing panel and door is achieved by inserting cage nut in front square and installing screw through rear hole of vertical rails.

SQUARE CUT OUT	DISTANCE BETWEEN INSIDE OF DOOR AND SWING PANEL (REAR HOLE OF VERTICAL RAIL)	DISTANCE BETWEEN INSIDE OF DOOR AND SWING PANEL (FRONT HOLE OF VERTICAL RAIL)
FRONT	1.285"	2.223"
MIDDLE	2.035"	2.973"
BACK	2.785"	3.723"

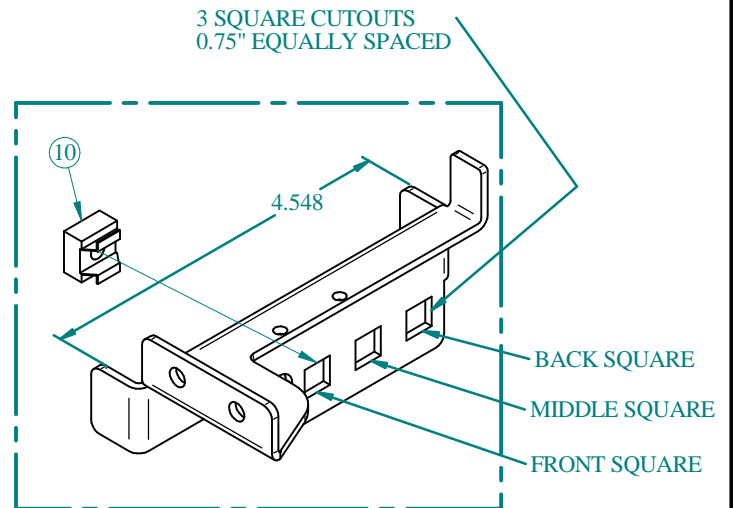

FIG. 2

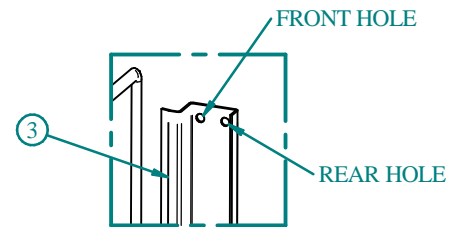

FIG. 2.1

3. Install mounting brackets. (Fig. 3)

- a) Assemble button head screws and sealing washers. Ensure rubber side of sealing washer is facing enclosure.
 b) Insert assembled button head screw and sealing washer through drilled holes and attach to mounting bracket tighten using allen key.

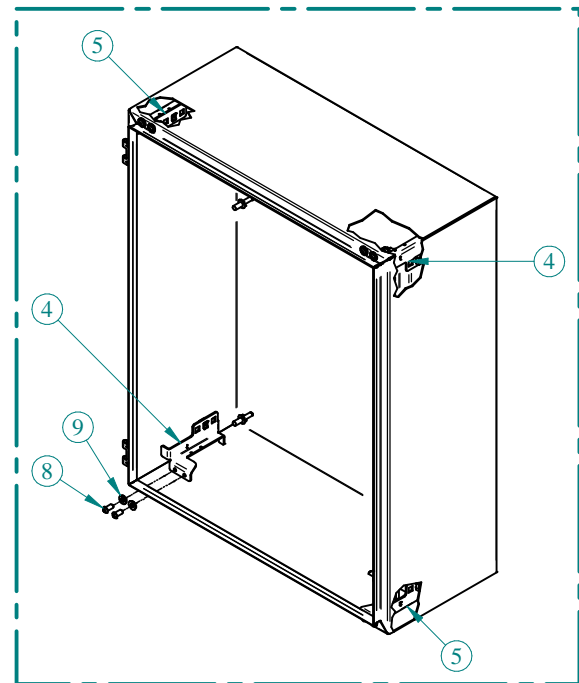

FIG. 3

TOOL BOX	3/8, 7/16" Socket Wrench	3/8 or 7/16 Open Wrench	Centre Punch	Drill, use .281(7.1mm) BIT	5/32 ALLEN KEY



ASSEMBLY INSTRUCTIONS FOR SWING PANEL AND SWING FRAME

4. Install vertical rails. (Fig. 4)

- a) Insert 1/4-20 screw through slot in vertical rail hinge side. Tighten screw by hand.
- b) Adjust vertical rails to desired location and tighten screw using 3/8 wrench.
- c) Repeat steps for vertical rail lock side.

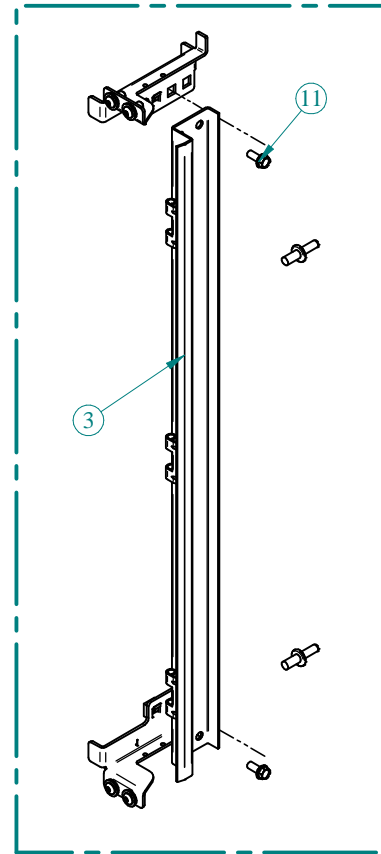

FIG. 4

5. Install 1/4 turn latches. (Fig. 5)

- a) Remove nut from 1/4 turn latches.
- b) Insert 1/4 turn latch through finger pull.
- c) Insert 1/4 turn latch into swing panel latch cut out.
- d) Ensure latches rotate as shown. (Fig. 6)
- e) Install nut back onto 1/4 turn latches.

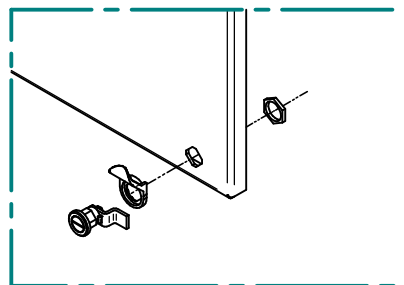

FIG. 5

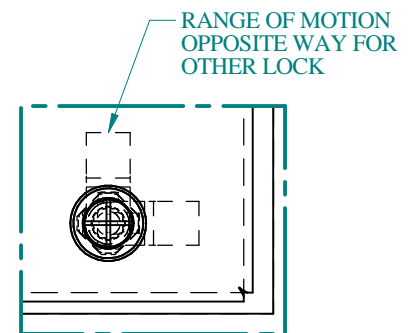

FIG. 6

TOOL BOX	3/8, 7/16" Socket Wrench	3/8 or 7/16 Open Wrench	Centre Punch	Drill, use .281(7.1mm) BIT	5/32 ALLEN KEY

ASSEMBLY INSTRUCTIONS FOR SWING PANEL AND SWING FRAME

6. Install swing panel/frame. (Fig. 7)
- a) Place swing panel/frame hinge barrels between vertical rail hinges.
 - b) Insert pins through hinge and barrel.
 - c) Insert pin caps.

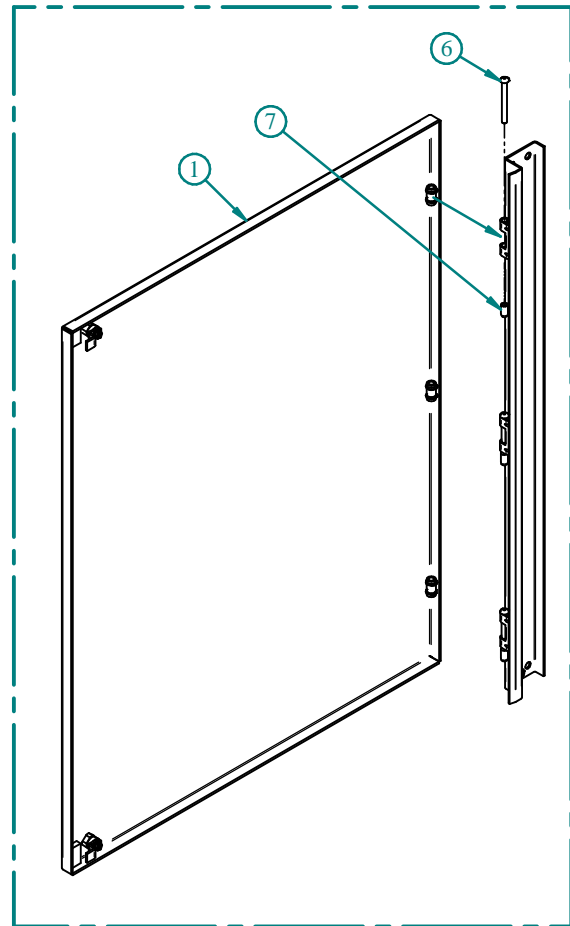
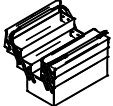









FIG. 7

TOOL BOX	3/8, 7/16" Socket Wrench	3/8 or 7/16 Open Wrench	Centre Punch	Drill, use .281(7.1mm) BIT	5/32 ALLEN KEY
					

Looking for pricing, stock, or lifecycle information?

Click below to explore more details on WIN SOURCE:

-  [View ESP4836 on WIN SOURCE](#)
-  [Hammond Manufacturing Information](#)

Optimize Your Supply Chain with WIN SOURCE Solutions

-  Global Sourcing Solution
-  Obsolete Management
-  Cost Control Management
-  Shortage Management
-  Alternative Solution
-  Excess Inventory Management