



**THE DATASHEET OF
STR-W6253MD**



60 W-Universal Input/90 W-230 Vac Input PWM Switching Regulators

Features and Benefits

- Overcurrent protection (OCP) with AC input voltage compensation function; no additional peripheral circuits required—minimizes dependency of OCP on ac input
- Overload protection (OLP) with integrated timer reduces power stress (temperature rise) at overload condition, requires no peripheral components
- Avalanche-guaranteed MOSFET improves device capability of withstanding excess surge voltage, providing a simple surge absorber circuit without breakdown voltage derating
- Start-up circuit eliminates the need for a start-up resistor, and helps to reduce input power consumption

Continued on the next page...

Package: TO-220



Not to scale

Description

The STR-W6200D series are current-mode PWM ICs that incorporate controller chips. These devices are manufactured using a proprietary high-voltage BCD process, and avalanche-guaranteed MOSFETs. These elements allow power supply systems designs that are highly reliable and simple, with fewer peripheral components. These ICs also provide Auto-Burst mode operation, which lowers input power requirements at light loads, and improves efficiency over the entire load range and universal-input range.

Applications include:

- TV set top box
- LCD PC monitor, LCD TV
- Printer, scanner
- General consumer, PC, and industrial applications requiring SMPS power supply with standby mode

Functional Block Diagram

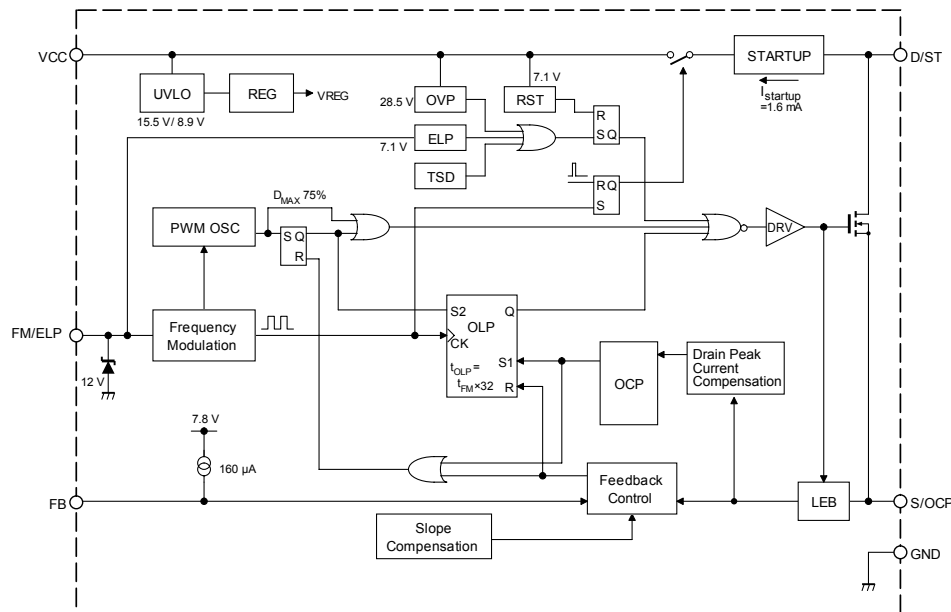

Features and Benefits (continued)

- Bias Assist function improves start-up performance by self-biasing the VCC pin, and allows a use of a small value VCC capacitor, resulting in improved response to overvoltage conditions
- Very low current consumption in nonoperating (UVLO) state: $I_{CC(off)} = 5 \mu A$ (typical) at $V_{CC} = 13.9 V$
- Slope compensation circuit stabilizes operation, preventing interference from subharmonics
- Leading Edge Blanking
- Various protections:
 - Overcurrent Protection (OCP), pulse-by-pulse sensing
 - Overload Protection (OLP), auto restart after certain duration
 - External Latch Protection (ELP), latched
 - Overvoltage Protection (OVP), latched
 - Thermal Shut Down (TSD), latched
- Externally-activated shut down protection (ELP) for emergency system shut down
- Auto-Burst Standby function (pin $< 0.1 W$ at zero output load condition)
- TO-220 full-molded package with 6 pins

Selection Guide

Part Number	Packing
STRW6253MD	50 pieces per tube

Pin-out Diagram

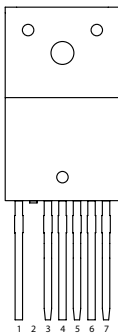

Terminal List Table

Number	Name	Description	Functions
1	D/ST	Drain/startup terminal	MOSFET drain and input of start-up signal
2	NC	Clipped	No connection
3	S/OCP	Source/Overcurrent Protection terminal	MOSFET source and input of overcurrent detection signal
4	VCC	Power supply terminal	Input of power supply for control circuit
5	GND	Ground terminal	Ground
6	FB	Feedback terminal	Input of constant voltage control signal
7	FM/ELP	Frequency jittering/External Latch Protection terminal	Control input for frequency jittering control and External Latch Protection

All performance characteristics given are typical values for circuit or system baseline design only and are at the nominal operating voltage and an ambient temperature, T_A , of 25°C, unless otherwise stated.

ABSOLUTE MAXIMUM RATINGS at $T_A = 25^\circ\text{C}$

Characteristic	Symbol	Terminal	Note	Rating	Unit
Drain Current ¹	I_{Dpeak}	1-3	Single Pulse	10	A
Maximum Switching Current ²	I_{DMAX}	1-3	$T_A = -20^\circ\text{C}$ to 125°C	10	A
Single Pulse Avalanche Energy ³	E_{AS}	1-3	Single Pulse	86	mJ
	I_{Lpeak}	1-3	$V_{DD} = 99\text{ V}$, $L = 20\text{ mH}$	2.7	A
S/OCP Terminal Voltage	V_{OCP}	3-5		-6 to 6	V
FM/ELP Terminal Voltage	V_{FM}	7-5		-0.3 to 12	V
FM/ELP Terminal Inflow Current	I_{FM}	7-5		3	mA
FB Terminal Voltage	V_{FB}	6-5		-0.3 to 9	V
Controller (MIC) Input Voltage	V_{CC}	4-5		0 to 32	V
MOSFET Power Dissipation ⁴	P_{D1}	1-3	With infinite heatsink	27.5	W
			Without heatsink	1.3	W
Controller (MIC) Power Dissipation	P_{D2}	4-5		0.8	W
Operating Internal Frame Temperature	T_F	-	Refer to T_{OP}	-20 to 115	$^\circ\text{C}$
Operating Ambient Temperature	T_{op}	-		-20 to 115	$^\circ\text{C}$
Storage Temperature	T_{stg}	-		-40 to 125	$^\circ\text{C}$
Channel Junction Temperature	T_J	-		150	$^\circ\text{C}$

¹Refer to figure 1

² I_{DMAX} is the drain current on the D/ST pin determined by the drive voltage of the IC and the threshold voltage, V_{th} , of the MOSFET

³Refer to figure 3

⁴Refer to figure 5

Figure 1 – MOSFET Safe Operating Area Derating Curve

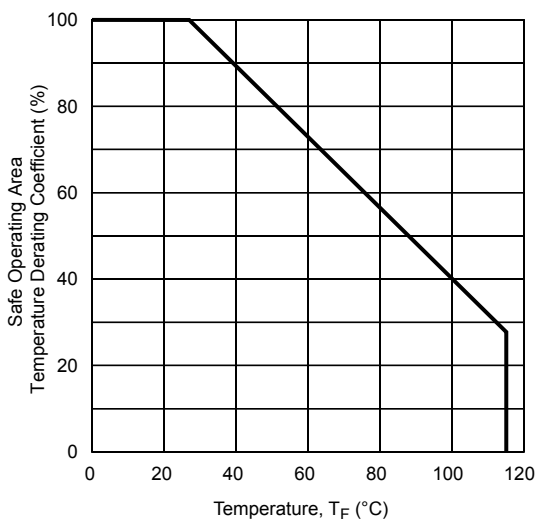

Figure 2 – MOSFET Safe Operating Area Drain Current versus Voltage at $T_A = 25^\circ\text{C}$, Single Pulse

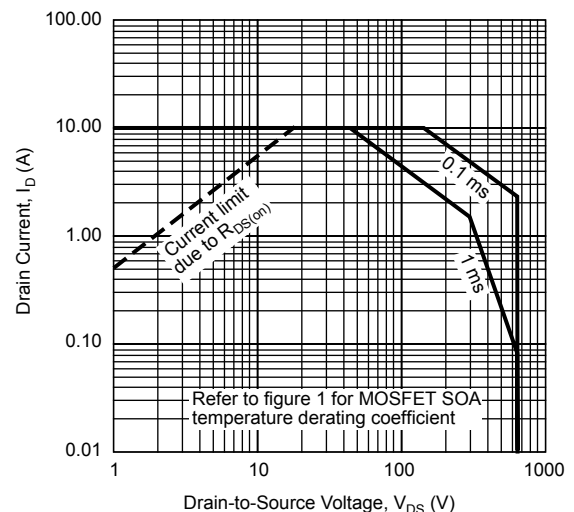

Figure 3 – MOSFET Avalanche Energy Derating Curve

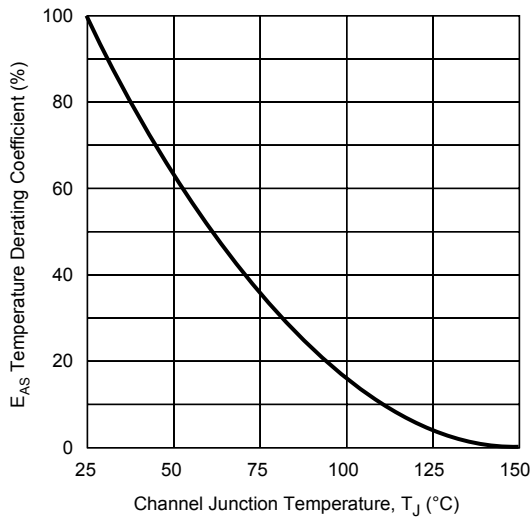

Figure 4 – Transient Thermal Resistance

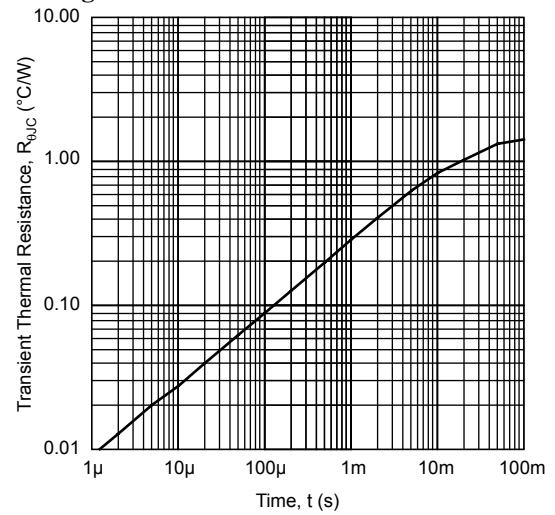
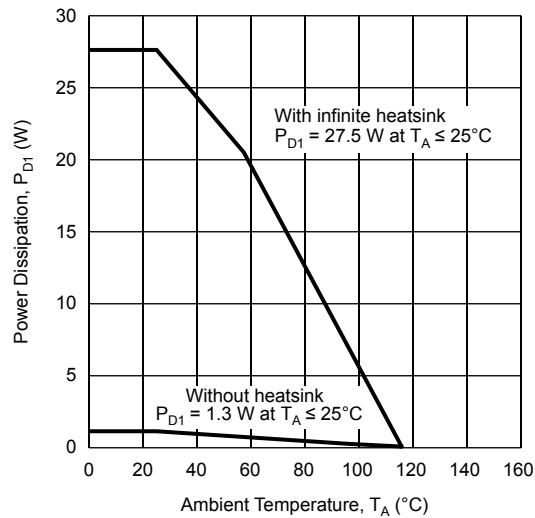

Figure 5 – MOSFET Power Dissipation versus Temperature



ELECTRICAL CHARACTERISTICS valid at $V_{CC} = 18\text{ V}$, $T_A = 25^\circ\text{C}$, unless otherwise specified

Characteristic	Symbol	Terminal	Test Conditions	Min.	Typ.	Max	Units
Power Supply Start-up Operation							
Operation Start Voltage	$V_{CC(ON)}$	4-5	(VCC voltage at which operation starts) Measurement circuit 1, $V_{CC} = 0$ through 13.9 to 17.1 V	13.9	15.5	17.1	V
Operation Stop Voltage	$V_{CC(OFF)}$	4-5	(VCC voltage at which operation stops) Measurement circuit 1, $V_{CC} = 17.1$ through 9.8 to 8.0 V	8.0	8.9	9.8	V
Circuit Current in Operation	$I_{CC(ON)}$	4-5	(Inflow current into VCC terminal in oscillation) Measurement circuit 1	–	1.4	2.8	mA
Circuit Current in Non-Oscillation	$I_{CC(STOP)}$	4-5	(Inflow current into VCC terminal at $V_{FB} = 0\text{ V}$) Measurement circuit 1	–	0.8	1.3	mA
Circuit Current in Non-Operation	$I_{CC(OFF)}$	4-5	(Inflow current into VCC terminal prior to oscillation) Measurement circuit 1, $V_{CC} = 13.8$	–	5	20	μA
Start-up Current	$I_{startup}$	4-5	(Inflow current into D/ST terminal) Measurement circuit 7, $V_{CC} = 0$, D/ST = 450 V	–0.9	–1.6	–2.3	mA
Bias Assist Voltage	V_{BIAS}	4-5	(VCC voltage at which $I_{startup}$ starts, and $I_{startupBias}$ begins) Measurement circuit 7, $V_{CC} = 17.1$ through 13.6 to 16.8 V	13.6	15.2	16.8	V
Operating Characteristics							
FM/ELP High Threshold Voltage	$V_{FM(H)}$	7-5	(FM/ELP terminal voltage at which I_{FM} changes from $-13\ \mu\text{A}$ to $13\ \mu\text{A}$) Measurement circuit 2	4.0	4.5	5.0	V
FM/ELP Low Threshold Voltage	$V_{FM(L)}$	7-5	(FM/ELP terminal voltage at which I_{FM} changes from $13\ \mu\text{A}$ to $-13\ \mu\text{A}$) Measurement circuit 2	2.4	2.8	3.2	V
FM/ELP Voltage Difference	ΔV_{FM}	7-5	($V_{FM(H)} - V_{FM(L)}$) Measurement circuit 2	1.4	1.7	1.8	V
FM/ELP Outflow Current ¹	I_{FMsrc}	7-5	(FM/ELP terminal outflow current at $V_{FM} = V_{FM(L)}$) Measurement circuit 2	–17.4	–13	–8.6	μA
FM/ELP Inflow Current ¹	I_{FMsink}	7-5	(FM/ELP terminal inflow current at $V_{FM} = V_{FM(H)}$) Measurement circuit 2	8.6	13	17.4	μA
Average Switching Frequency	$f_{OSC(av)}$	1-5	(D/ST terminal average oscillation frequency) Measurement circuit 2	60	67	74	kHz
Frequency Jitter Deviation	Δf	1-5	f_{OSC} (peak-to-peak) Measurement circuit 2	4.8	6.9	9	kHz
Maximum Duty Cycle (On-Duty)	D_{MAX}	1-5	(Maximum width of the low portion of the D/ST terminal waveform) Measurement circuit 2	71	75	79	%
Maximum Feedback Current ¹	$I_{FB(MAX)}$	6-5	(FB terminal outflow current at $V_{FB} = 0\text{ V}$) Measurement circuit 3	–220	–160	–100	μA
Standby Operation Start-up Threshold Voltage	V_{STBY}	6-5	Set $V_{FM} = 0\text{ V}$ and decrease V_{FB} (V_{STBY} is the FB terminal voltage level at which D/ST changes from low to high) Measurement circuit 3	0.99	1.10	1.21	V
Slope Compensation Start-up Duty Cycle	D_{SLP}	6-5	$D_{SLP} = (\beta / t_4) \times 100$ (see figure for measurement circuit 4 for values of t) Measurement circuit 4	–	27	–	%
Slope Compensation Rate	SLP	6-5	$SLP = 0.02 / (t_2 - t_1)$ (see figure for measurement circuit 4 for values of t) Measurement circuit 4	–22	–17	–12	mV/ μs

Continued on next page...

ELECTRICAL CHARACTERISTICS, continued, valid at $V_{CC} = 18\text{ V}$, $T_A = 25^\circ\text{C}$, unless otherwise specified

Characteristic	Symbol	Terminal	Test Conditions	Min.	Typ.	Max	Units
Protection Operation							
OCP Threshold Voltage at Zero Duty Cycle (0% On-Duty)	V_{OCP1}	3-5	Set $V_{FM} = 0\text{ V}$ and increase V_{OCP} . (V_{OCP1} is the S/OCP terminal voltage level at which D/ST changes from low to high) Measurement circuit 5	0.71	0.78	0.86	V
Drain Peak Current Compensation Coefficient	D_{PC}	–	$D_{PC} = -0.75 \times SLP / f_{OSC(av)}$	1.5	1.9	2.3	mV/DC%
OCP Threshold Voltage After Compensation	V_{OCP2}	3-5	$V_{OCP2} = D_{PC} \times D_{MAX} + V_{OCP1}$	0.82	0.93	1.04	V
Leading Edge Blanking Time	t_{blank}	1-5	(The low portion of the D/ST terminal waveform at $V_{OCP} = 2\text{ V}$) Measurement circuit 5	280	400	520	ns
OLP Delay Time ²	t_{OLP}	1-5	(Time between setting FB terminal open and when oscillation stops) Measurement circuit 6	–	400	–	ms
Circuit Current in OLP-Operation	$I_{CC(OLP)}$	4-5	(Inflow current into VCC terminal after OLP operation) Measurement circuit 6	–	1.2	1.9	mA
OVP Protection Voltage	$V_{CC(OVP)}$	4-5	Set $V_{FM} = 0\text{ V}$ and increase V_{CC} (V_{CC} terminal voltage at which the voltage of D/ST terminal is switched from low to high) Measurement circuit 1, $V_{CC} = 18.0\text{ V}$ through 27 to 30 V	27	28.5	30	V
Latch Circuit Sustaining Current ³	$I_{CC(La,H)}$	4-5	(Inflow current into VCC terminal after OVP operation) Measurement circuit 1, $V_{CC} = 8\text{ V}$	–	140	220	μA
Latch Circuit Release Voltage ³	$V_{CC(La,OFF)}$	4-5	(V_{CC} voltage at which I_{CC} is dropped below 20 μA by decreasing V_{CC} after OVP operation) $V_{CC} = 31.0\text{ V}$ through 7.8 to 6.4 V	6.4	7.1	7.8	V
ELP Threshold Voltage	V_{ELP}	7-5	(FM/ELP terminal voltage at which the oscillation of the D/ST terminal waveform is stopped by increasing V_{FM}) Measurement circuit 2	6.4	7.1	7.8	V
Inflow Current at External Latch Protection	I_{ELP}	7-5		–	55	100	μA
Thermal Shutdown Operating Temperature	T_{JTSD}	–		135	–	–	$^\circ\text{C}$
Power MOSFET Characteristics							
Drain-to-Source Breakdown Voltage	V_{DSS}	1-3	$I_D = 300\ \mu\text{A}$, Measurement circuit 8	650	–	–	V
Drain Leakage Current	I_{DSS}	1-3	$V_{DS} = 650\text{ V}$, $V_{CC} = 13\text{ V}$, Measurement circuit 7	–	–	300	μA
ON-Resistance	$R_{DS(ON)}$	1-3	$I_D = 1.2\text{ A}$, $V_{FM} = 0\text{ V}$ Measurement circuit 10	–	–	1.9	Ω
Switching Time	t_r	1-3	Measurement circuit 9	–	–	400	ns
Thermal Resistance	$R_{\theta J-F}$	–	Measured between junction and internal frame	–	–	1.75	$^\circ\text{C/W}$
Single Pulse Avalanche Energy	E_{AS}	–	Measurement circuit 11	–	–	–	–

¹Input and output current polarity at the device pin; plus(+) represents sink and minus(–) represents source.

²The reference value when applying 47 nF between the FM/ELP terminal and GND.

³The latch circuit means a circuit operated ELP, OVP, TSD, and OLP.

Measurement Circuit 1

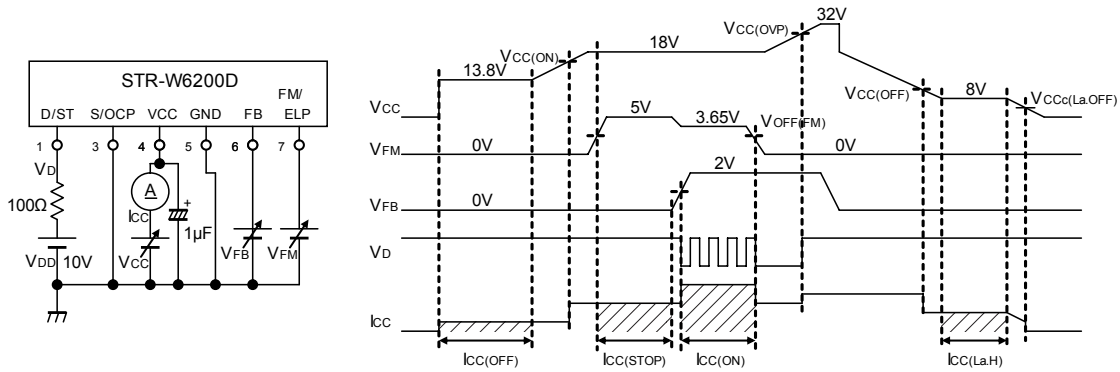

Measurement Circuit 2

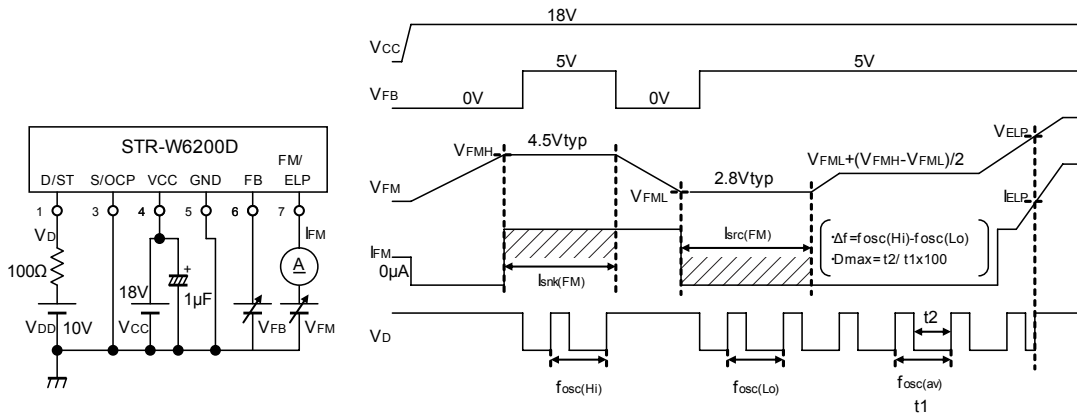

Measurement Circuit 3

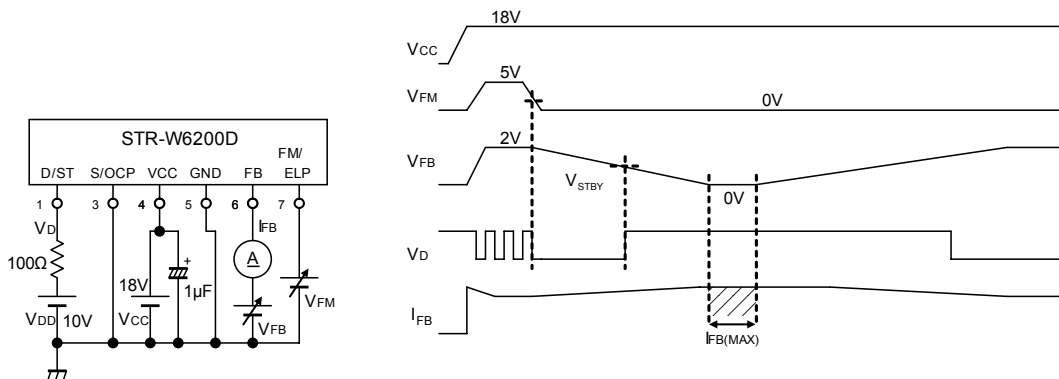

STR-W6253MD

60 W-Universal Input/90 W-230 Vac Input PWM Switching Regulators

Measurement Circuit 4

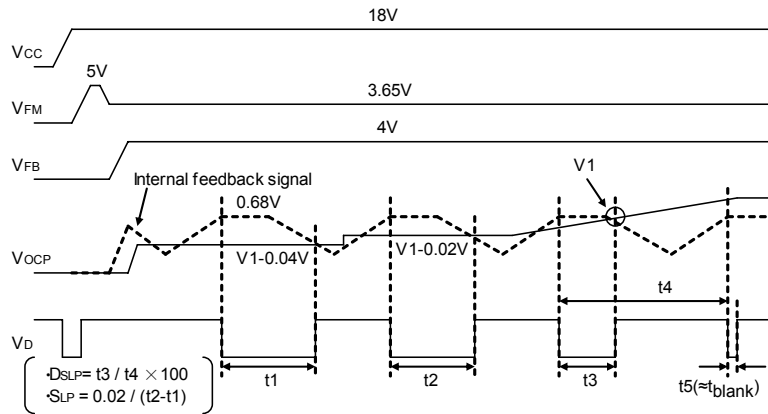
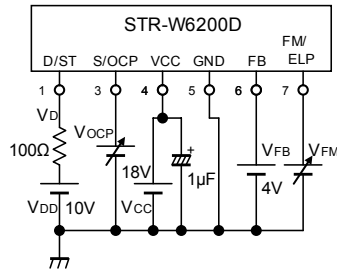

Measurement Circuit 5

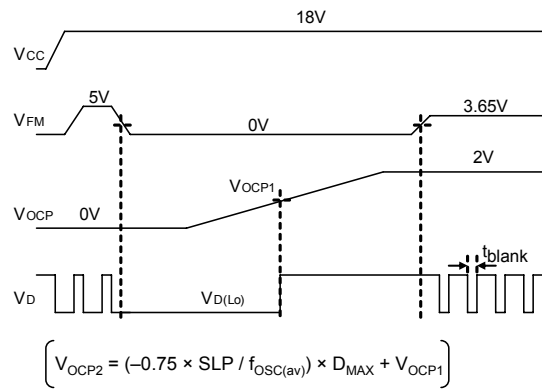
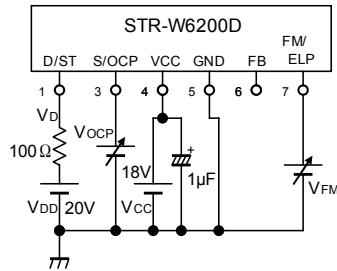

Measurement Circuit 6

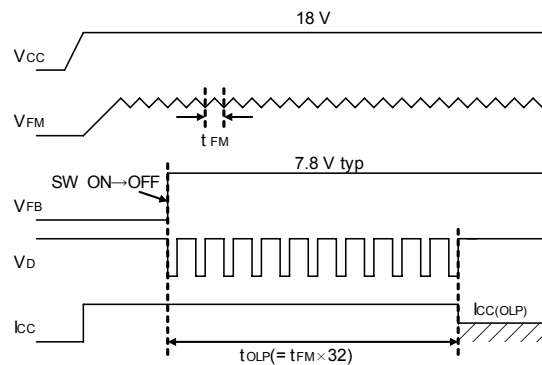
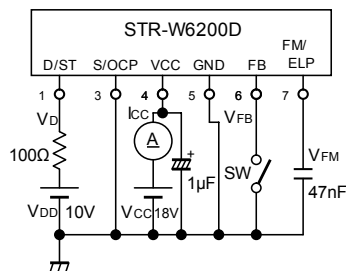

STR-W6253MD

60 W-Universal Input/90 W-230 Vac Input PWM Switching Regulators

Measurement Circuit 7

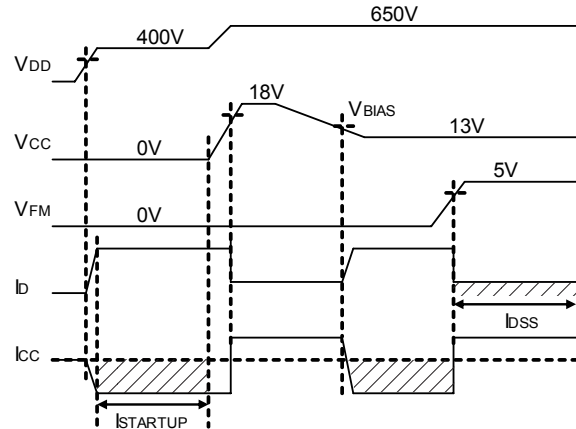
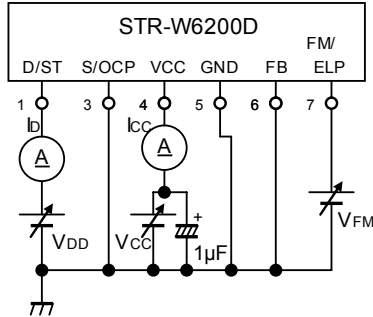

Measurement Circuit 8

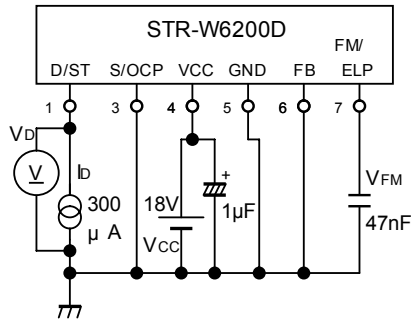

Measurement Circuit 9

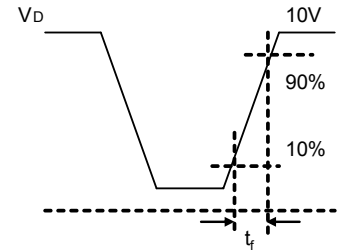
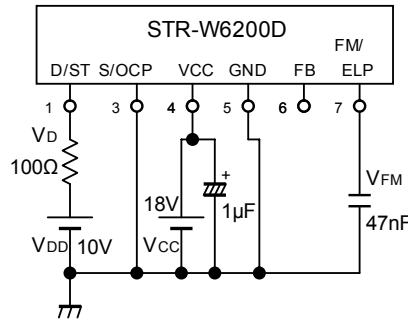

Measurement Circuit 10

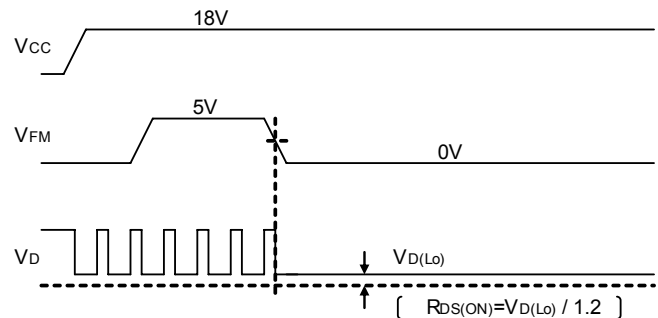
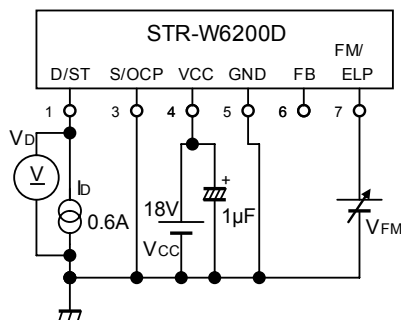

Measurement Circuit 11

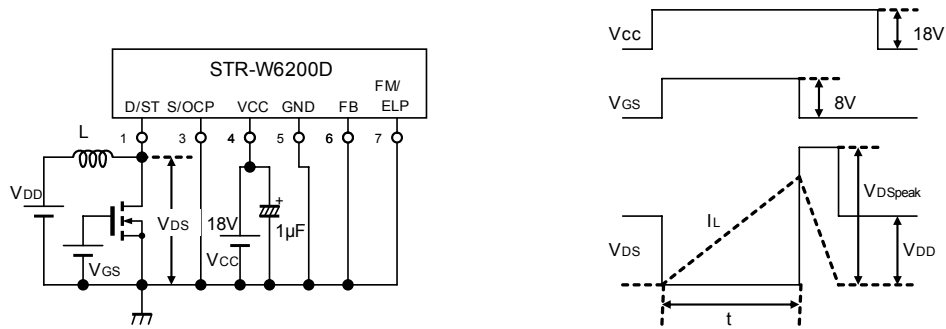

TYPICAL APPLICATION CIRCUIT

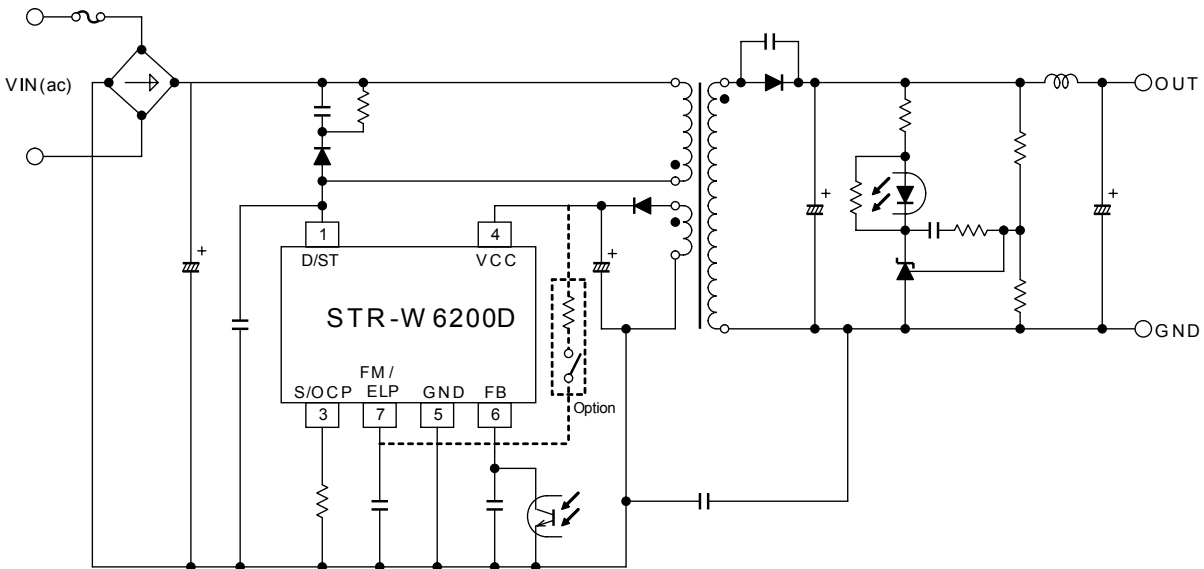

STR-W6253MD

60 W-Universal Input/90 W-230 Vac Input PWM Switching Regulators

PACKAGE DIMENSIONS, TO-220

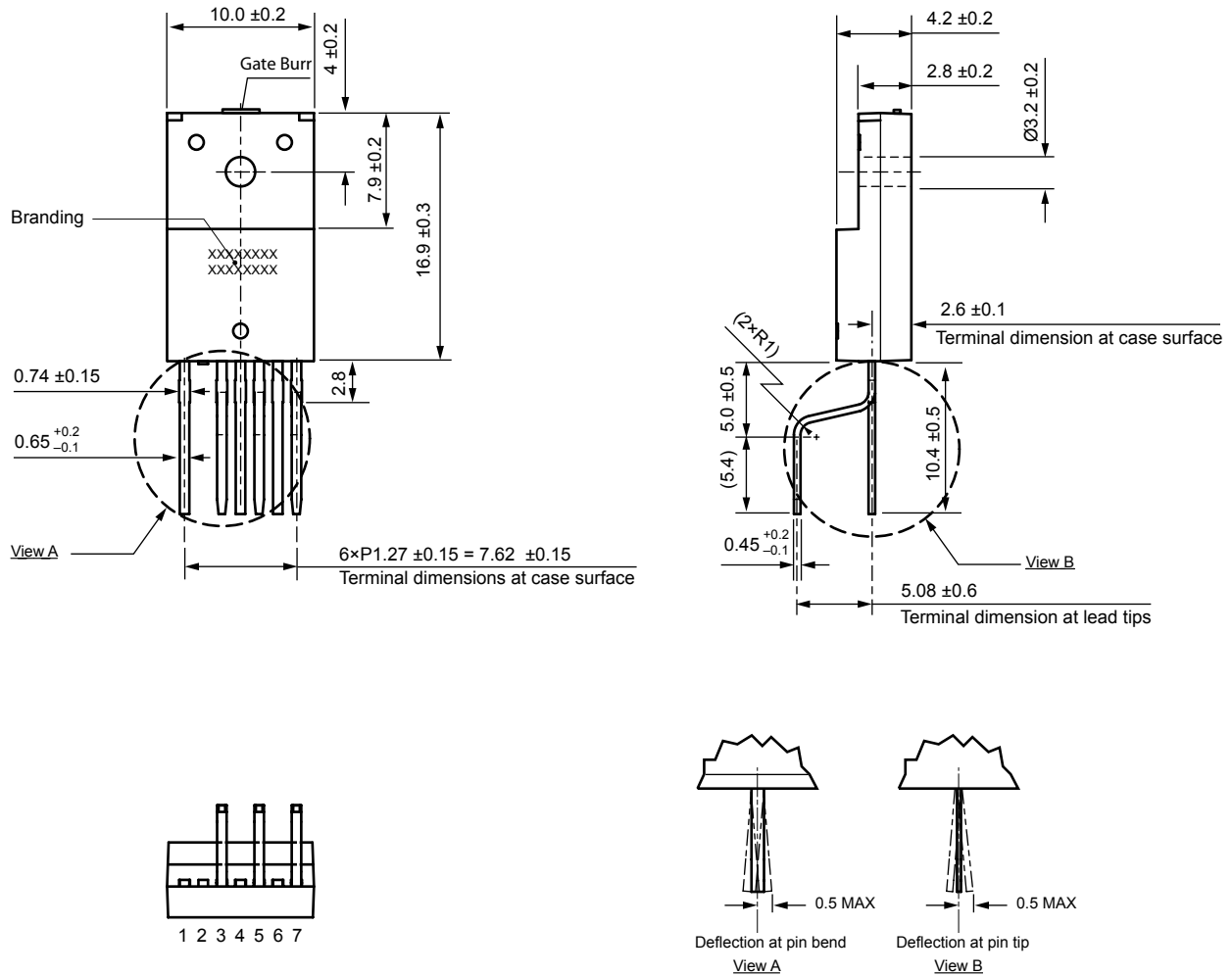

Terminal core material: Cu
Terminal treatment: Ni plating and solder dip

Leadform: 2003
Weight (approximate): 2.3 g

Dimensions in millimeters

Drawing for reference only
Branding codes (exact appearance at manufacturer discretion):
1st line, type: W6253DM
2nd line, lot: YMDD R
Where: Y is the last digit of the year of manufacture
M is the month (1 to 9, O, N, D)
DD is the 2-digit date
R is the manufacturer registration symbol

Leadframe plating Pb-free. Device composition complies with the RoHS directive.

STR-W6253MD

60 W-Universal Input/90 W-230 Vac Input PWM Switching Regulators

PACKING SPECIFICATIONS Minimum packing option: Tube FM-205 E

Shipping Tube Dimensions:
 Wall thickness: 0.6 ± 0.3 mm
 Wall warp: < 2 mm
 Material: Hardened polyvinyl
 Coating: antistatic
 Tolerance ± 0.4 mm,
 unless otherwise specified

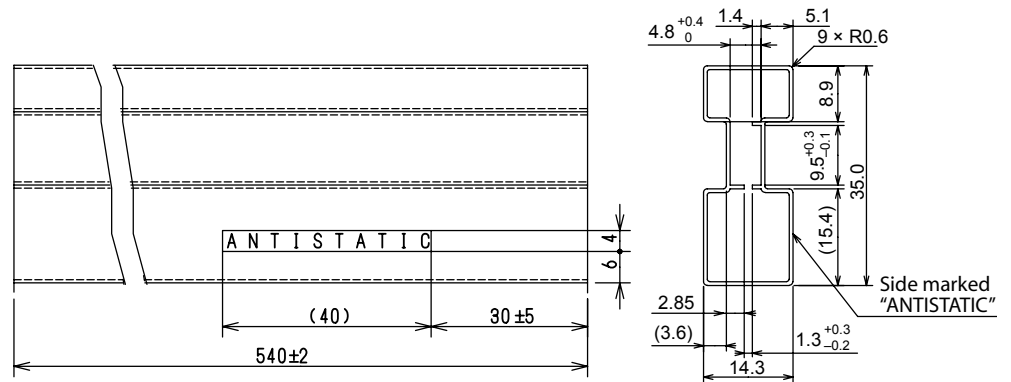

Shipping Carton Dimensions:
 Capacity: 1800 pieces maximum per carton
 36 tubes per carton
 3 rows, 12 tubes per row

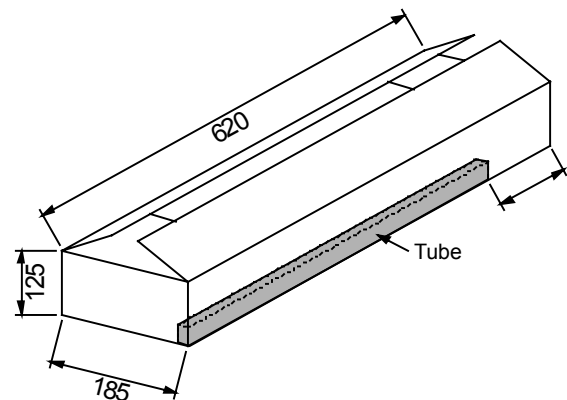
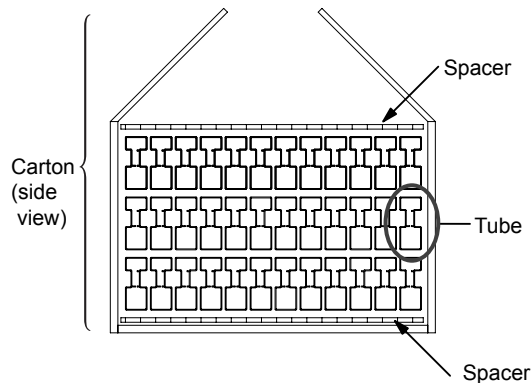

All dimensions: mm

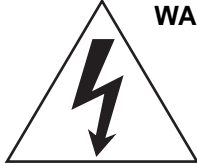

WARNING — These devices are designed to be operated at lethal voltages and energy levels. Circuit designs that embody these components must conform with applicable safety requirements. Precautions must be taken to prevent accidental contact with power-line potentials. Do not connect grounded test equipment.

The use of an isolation transformer is recommended during circuit development and breadboarding.

Because reliability can be affected adversely by improper storage environments and handling methods, please observe the following cautions.

Cautions for Storage

- Ensure that storage conditions comply with the standard temperature (5°C to 35°C) and the standard relative humidity (around 40 to 75%); avoid storage locations that experience extreme changes in temperature or humidity.
- Avoid locations where dust or harmful gases are present and avoid direct sunlight.
- Reinspect for rust in leads and solderability of products that have been stored for a long time.

Cautions for Testing and Handling

When tests are carried out during inspection testing and other standard test periods, protect the products from power surges from the testing device, shorts between adjacent products, and shorts to the heatsink.

Remarks About Using Silicone Grease with a Heatsink

- When silicone grease is used in mounting this product on a heatsink, it shall be applied evenly and thinly. If more silicone grease than required is applied, it may produce stress.
- Volatile-type silicone greases may produce cracks after long periods of time, resulting in reduced heat radiation effect. Silicone grease with low consistency (hard grease) may cause cracks in the mold resin when screwing the product to a heatsink.
- Our recommended silicone greases for heat radiation purposes, which will not cause any adverse effect on the product life, are indicated below:

Type	Suppliers
G746	Shin-Etsu Chemical Co., Ltd.
YG6260	GE Toshiba Silicone Co., Ltd.
SC102	Dow Corning Toray Co., Ltd.

Soldering

- When soldering the products, please be sure to minimize the working time, within the following limits:
260±5°C 10 s
350±5°C 3 s
- Soldering iron should be at a distance of at least 1.5 mm from the body of the products

Electrostatic Discharge

- When handling the products, operator must be grounded. Grounded wrist straps worn should have at least 1 MΩ of resistance to ground to prevent shock hazard.
- Workbenches where the products are handled should be grounded and be provided with conductive table and floor mats.
- When using measuring equipment such as a curve tracer, the equipment should be grounded.
- When soldering the products, the head of soldering irons or the solder bath must be grounded in order to prevent leak voltages generated by them from being applied to the products.
- The products should always be stored and transported in our shipping containers or conductive containers, or be wrapped in aluminum foil.

Assembly

- During soldering or other operations, the interior frame temperature of the device should never exceed 105°C.
- Recommended screw torque through the mounting tab is 0.588 to 0.785 N • m (6 to 8 kgf • cm)

The products described herein are manufactured in Japan by Sanken Electric Co., Ltd. for sale by Allegro MicroSystems, Inc.

Sanken and Allegro reserve the right to make, from time to time, such departures from the detail specifications as may be required to permit improvements in the performance, reliability, or manufacturability of its products. Therefore, the user is cautioned to verify that the information in this publication is current before placing any order.

When using the products described herein, the applicability and suitability of such products for the intended purpose shall be reviewed at the users responsibility.

Although Sanken undertakes to enhance the quality and reliability of its products, the occurrence of failure and defect of semiconductor products at a certain rate is inevitable.

Users of Sanken products are requested to take, at their own risk, preventative measures including safety design of the equipment or systems against any possible injury, death, fires or damages to society due to device failure or malfunction.

Sanken products listed in this publication are designed and intended for use as components in general-purpose electronic equipment or apparatus (home appliances, office equipment, telecommunication equipment, measuring equipment, etc.). Their use in any application requiring radiation hardness assurance (e.g., aerospace equipment) is not supported.

When considering the use of Sanken products in applications where higher reliability is required (transportation equipment and its control systems or equipment, fire- or burglar-alarm systems, various safety devices, etc.), contact a company sales representative to discuss and obtain written confirmation of your specifications.

The use of Sanken products without the written consent of Sanken in applications where extremely high reliability is required (aerospace equipment, nuclear power-control stations, life-support systems, etc.) is strictly prohibited.

The information included herein is believed to be accurate and reliable. Application and operation examples described in this publication are given for reference only and Sanken and Allegro assume no responsibility for any infringement of industrial property rights, intellectual property rights, or any other rights of Sanken or Allegro or any third party that may result from its use.

Copyright © 2007 Allegro MicroSystems, Inc.

This datasheet is based on Sanken datasheet SSE24071



Allegro MicroSystems, Inc.
115 Northeast Cutoff, Box 15036
Worcester, Massachusetts 01615-0036 (508) 853-5000
www.allegromicro.com



Looking for pricing, stock, or lifecycle information?

Click below to explore more details on WIN SOURCE:

 [View STR-W6253MD](#) on WIN SOURCE

 [Sanken](#) Information

Optimize Your Supply Chain with WIN SOURCE Solutions

-  Global Sourcing Solution
-  Obsolete Management
-  Cost Control Management
-  Shortage Management
-  Alternative Solution
-  Excess Inventory Management