



**THE DATASHEET OF
TSC2117EVM-K**



Low-Power Audio Codec with Embedded miniDSP, Stereo Class-D Speaker Amplifier, and *Smart* Four-Wire Touch-Screen Controller

Check for Samples: [TSC2117](#)

1 INTRODUCTION

1.1 Features

- Low-Power 13-mW Stereo 48-kHz Playback
- Stereo Audio DAC and Monaural ADC Support 8-kHz to 192-kHz Sample Rates
- Instruction-Programmable miniDSP Available for Record and Playback Paths
- Bass Boost/Treble/EQ With up to Five Biquads for Record and up to Six Biquads for Playback
- Stereo 1.29-W Class-D BTL 8- Ω Speaker Driver With Direct Battery Connection
- *Smart* Four-Wire Touch-Screen Controller With Autonomous Timing
- Programmable-Gain Amplifiers
- Microphone Bias
- Hardware-Implemented AGC Used With Microphone Input for Audio ADC Path
- Digital Microphone Interface
- Digital Mixing Capability
- Pin Control or Register Control for Digital-Playback Volume-Control Settings
- Programmable 12-Bit SAR ADC
- Built-In Capability for Temperature, Battery, or

Auxiliary Measurements

- Programmable DRC for Digital Playback
- Sine-Wave Generator for Beep Generator for Touch-Pad Press Acknowledgement
- Integrated PLL Used for Programmable Digital Audio Processor
- SPI, I²C, and I²S Serial Interfaces
- SPI, I²C Have Register Auto-Increment
- Full Power-Down Control
- Power Supplies:
 - Analog: 2.7 V–3.6 V
 - Digital Core: 1.65 V–1.95 V
 - Digital I/O: 1.1 V–3.6 V
 - Class-D: 2.7 V–5.5 V (SLVDD and SRVDD \geq AVDD)
- 7-mm \times 7-mm 48-QFN Package

1.2 Applications

- Portable Gaming Devices
- Mobile Internet Devices
- Adaptive Filtering Applications

1.3 Description

The TSC2117 is a low-power, highly integrated, high-performance codec and touch-screen controller which features stereo class-D speaker amplifiers, a stereo audio DAC, mono audio ADC, and a SAR ADC.

The TSC2117 supports 16-bit stereo playback and monaural record functionality. The device integrates several analog features, such as a microphone interface, headphone drivers, and speaker drivers. The TSC2117 has two fully programmable miniDSPs for digital audio processing. The digital audio data format is programmable to work with popular audio standard protocols (I²S, left/right-justified) in master, slave, DSP, and TDM modes. Bass boost, treble, or EQ are supported by the preprogrammed modes of the programmable digital signal-processing block. An on-chip PLL provides the high-speed clock needed by the digital signal-processing block. The volume level can be controlled by either a pin control or by register control.

The TSC2117 has a 12-bit SAR ADC converter that supports a four-wire resistive touch-screen complete with drivers. All functions can be controlled by an I²C or SPI interface. A programmable beep generator is included. An on-chip processor is used in the touch-screen mode and provides extensive features specifically designed to reduce the host-processor and interface-bus overhead. The TSC2117 has three dedicated analog inputs for system voltage measurements, with an on-chip temperature sensor that can be read by the SAR ADC, and is available in a 7-mm \times 7-mm 48-pin QFN package.



Please be aware that an important notice concerning availability, standard warranty, and use in critical applications of Texas Instruments semiconductor products and disclaimers thereto appears at the end of this data sheet.

PurePath is a trademark of Texas Instruments.

MATLAB is a trademark of The MathWorks, Inc.

All other trademarks are the property of their respective owners.

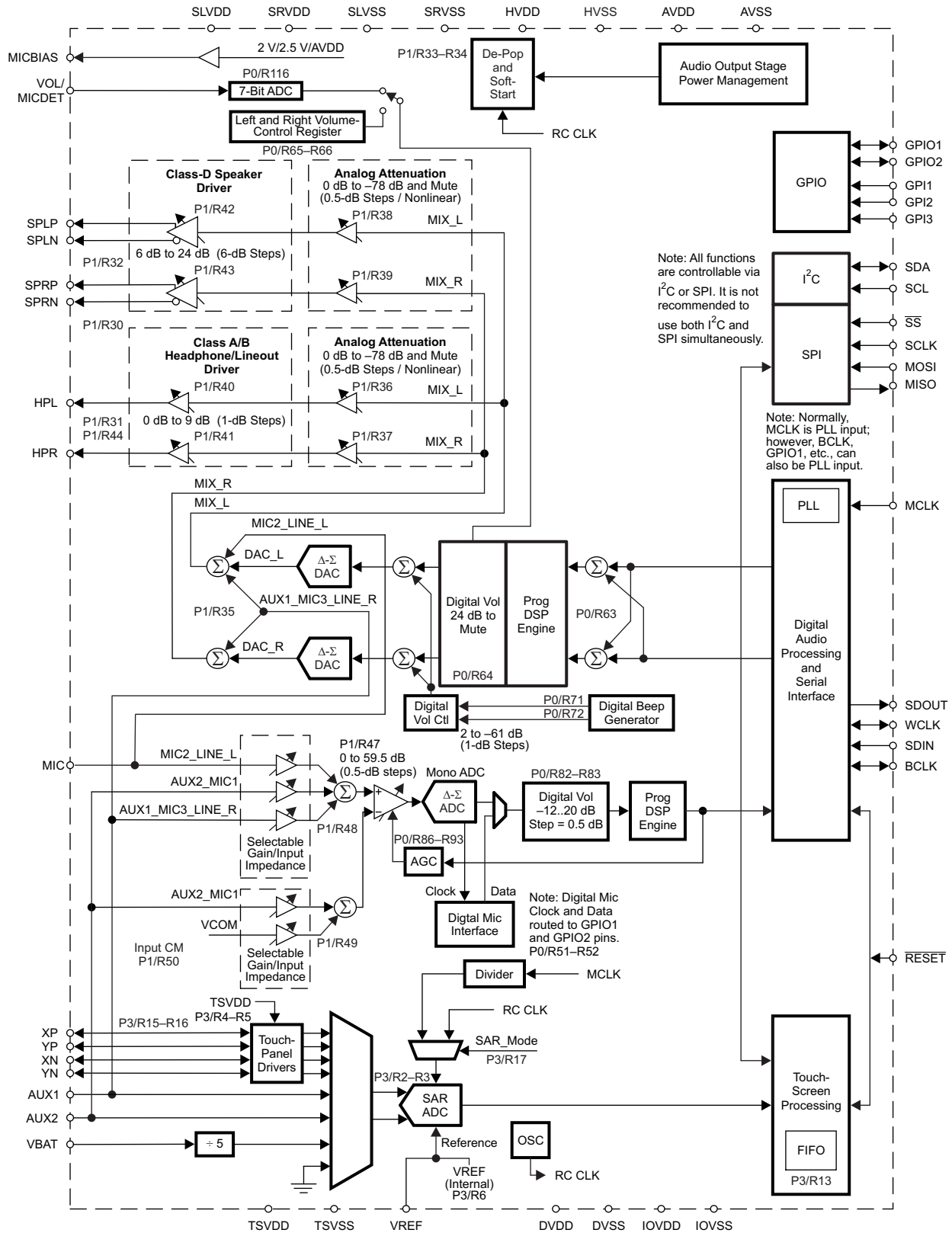

B0205-04

Figure 1-1. Functional Block Diagram

This integrated circuit can be damaged by ESD. Texas Instruments recommends that all integrated circuits be handled with appropriate precautions. Failure to observe proper handling and installation procedures can cause damage.

ESD damage can range from subtle performance degradation to complete device failure. Precision integrated circuits may be more susceptible to damage because very small parametric changes could cause the device not to meet its published specifications.

NOTE

This data manual is designed using PDF document-viewing features that allow quick access to information. For example, performing a global search on, e.g., "page 0/register 15" produces all references to this page and register in a list. This makes it easy to traverse the list and find all information related to a page and register. Note that the search string must be of the indicated format. Also, this document includes document hyperlinks to allow the user to quickly find a document reference. To come back to the original page, click the green left arrow near the PDF page number at the bottom of the file. The hot-key for this function is alt-left arrow on the keyboard. Another way to find information quickly is to use the PDF bookmarks.

2 PACKAGE AND SIGNAL DESCRIPTIONS

2.1 Package/Ordering Information

PRODUCT	PACKAGE	PACKAGE DESIGNATOR	OPERATING TEMPERATURE RANGE	ORDERING NUMBER	TRANSPORT MEDIA, QUANTITY
TSC2117	QFN-48	RGZ	–40°C to 85°C	TSC2117IRGZT	Tape and reel, 250
				TSC2117IRGZR	Tape and reel, 2500

2.2 Device Information

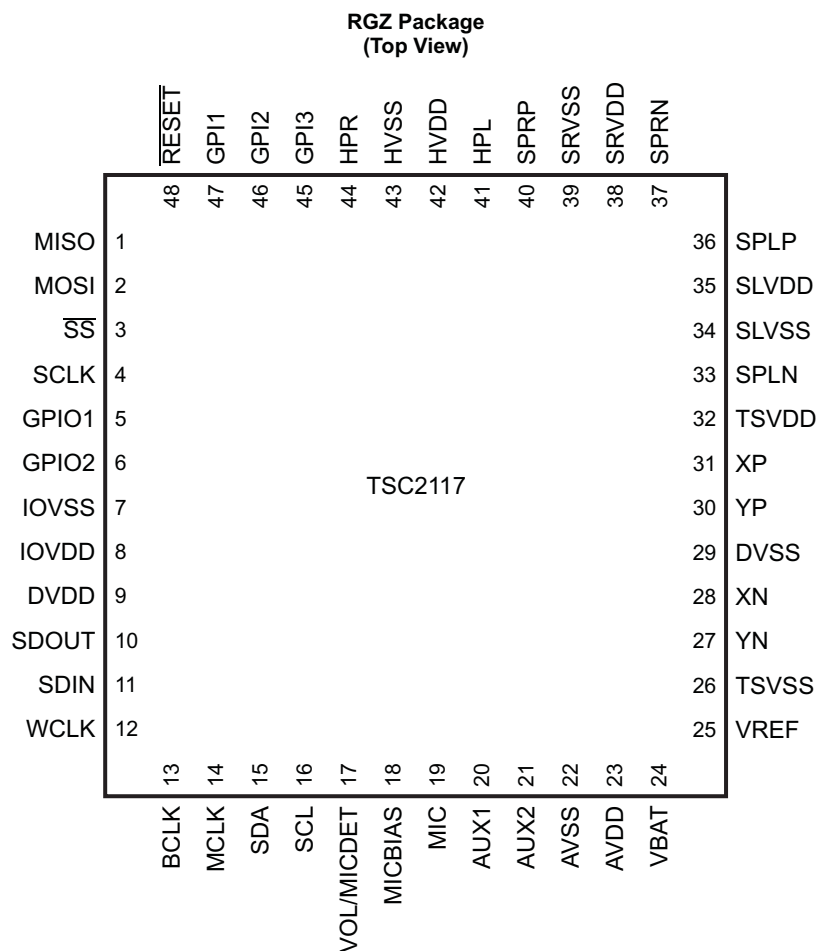

P0023-17

Table 2-1. TERMINAL FUNCTIONS

TERMINAL		I/O	DESCRIPTION
NAME	NO.		
AUX1	20	I	AUX1 (primary aux. input to SAR ADC), also routed to audio ADC input mixer and audio DAC output mixer
AUX2	21	I	AUX2 (secondary aux. input to SAR ADC), also routed to audio ADC input mixer
AVDD	23	–	Analog power supply
AVSS	22	–	Analog ground
BCLK	13	I/O	Audio serial clock
DVDD	9	–	Digital power – digital core
DVSS	29	–	Digital ground (internally connected to HVSS)
GPI1	47	I	General-purpose input and multifunction pin
GPI2	46	I	General-purpose input and multifunction pin
GPI3	45	I	General-purpose input and multifunction pin
GPIO1	5	I/O	General-purpose input/output pin and multifunction pin
GPIO2	6	I/O	General-purpose input/output pin and multifunction pin
HPL	41	O	Left-channel headphone driver output
HPR	44	O	Right-channel headphone driver output
HVDD	42	–	Headphone driver and PLL power
HVSS	43	–	Driver and PLL ground (internally connected to DVSS)

Table 2-1. TERMINAL FUNCTIONS (continued)

TERMINAL		I/O	DESCRIPTION
NAME	NO.		
IOVDD	8	–	Digital interface power
IOVSS	7	–	Digital interface ground
MCLK	14	I	External master clock
MIC	19	I	Microphone input (routed to audio ADC input mixer and audio DAC output mixer)
MICBIAS	18	O	Microphone bias voltage
MISO	1	O	Data output from SPI (Hi-Z capable)
MOSI	2	I	Data input to SPI
$\overline{\text{RESET}}$	48	I	Reset for logic and all internal registers – active-low
SCL	16	I/O	I ² C control bus clock input
SCLK	4	I	External clock to SPI
SDA	15	I/O	I ² C control-bus data I/O
SDIN	11	I	Playback audio serial-data input
SDOUT	10	O	Record audio serial-data output (hi-Z capable)
SLVDD	35	–	Left-channel class-D speaker-amplifier power supply
SLVSS	34	–	Left-channel class-D speaker-amplifier power-supply ground
SPLN	33	O	Left-channel speaker-driver inverting output
SPLP	36	O	Left-channel speaker-driver noninverting output
SPRN	37	O	Right-channel speaker-driver inverting output
SPRP	40	O	Right-channel speaker-driver noninverting output
SRVDD	38	–	Right-channel class-D speaker-amplifier power supply
SRVSS	39	–	Right-channel class-D speaker-amplifier power-supply ground
$\overline{\text{SS}}$	3	I	SPI chip select – active-low
TSVDD	32	–	Touch-screen controller power (used for touch-screen panel driver)
TSVSS	26	–	Touch-screen driver ground
VBAT	24	I	Battery-monitor input to SAR ADC
VOL/MICDET	17	I	Playback digital volume control or microphone-detection functionality
VREF	25	I/O	Voltage reference input for SAR ADC
WCLK	12	I/O	Audio serial-bus channel clock
XN	28	I/O	Touch-screen X– positional input and driver
XP	31	I/O	Touch-screen X+ positional input and driver
YN	27	I/O	Touch-screen Y– positional input and driver
YP	30	I/O	Touch-screen Y+ positional input and driver

3 ELECTRICAL SPECIFICATIONS

3.1 Absolute Maximum Ratings

over operating free-air temperature range (unless otherwise noted) ⁽¹⁾

	VALUE	UNIT
AVDD to AVSS	–0.3 to 3.9	V
DVDD to DVSS	–0.3 to 2.5	V
HVDD to HVSS	–0.3 to 3.9	V
SLVDD to SLVSS	–0.3 to 6	V
SRVDD to SRVSS	–0.3 to 6	V
IOVDD to IOVSS	–0.3 to 3.9	V
TSVDD to TSVSS	–0.3 to 3.9	V
VREF to AVSS	AVSS – 0.3 to AVDD	V
Digital input voltage	IOVSS – 0.3 to IOVDD + 0.3	V
Analog input voltage	AVSS – 0.3 to AVDD + 0.3	V
VBAT	–0.3 to 6	V
Operating temperature range	–40 to 85	°C
Storage temperature range	–55 to 150	°C
Junction temperature (T _J Max)	105	°C
QFN package	Power dissipation	(T _J Max – T _A)/R _{θJA}
	R _{θJA} Thermal impedance (with thermal pad soldered to board)	27
Lead temperature	Infrared (15 s)	300
		°C

- (1) Stresses beyond those listed under *Absolute Maximum Ratings* may cause permanent damage to the device. These are stress ratings only, and functional operation of the device at these or any other conditions beyond those indicated under *Recommended Operating Conditions* is not implied. Exposure to absolute-maximum-rated conditions for extended periods may affect device reliability.

Table 3-1. System Thermal Characteristics⁽¹⁾

Power Rating at 25°C	Derating Factor	Power Rating at 70°C	Power Rating at 85°C
3 W	37.04 mW/°C	1.3 W	0.74 W

- (1) This data was taken using 2-oz. (0.071-mm thick) trace and copper pad that is soldered to a JEDEC high-K, standard 4-layer 3-in. × 3 in. (7.62-cm × 7.62-cm) PCB.

3.2 Recommended Operating Conditions

over operating free-air temperature range (unless otherwise noted)

			MIN	NOM	MAX	UNIT
AVDD ⁽¹⁾	Power-supply voltage range	Referenced to AVSS ⁽²⁾	2.7	3.3	3.6	V
DVDD		Referenced to DVSS ⁽²⁾	1.65	1.8	1.95	
HVDD		Referenced to HVSS ⁽²⁾	2.7	3.3	3.6	
SLVDD ⁽¹⁾		Referenced to SLVSS ⁽²⁾	2.7		5.5	
SRVDD ⁽¹⁾		Referenced to SRVSS ⁽²⁾	2.7		5.5	
TSVDD		Referenced to TSVSS ⁽²⁾	2.7	3.3	3.6	
IOVDD		Referenced to IOVSS ⁽²⁾	1.1	3.3	3.6	
VREF	External voltage reference	Referenced to AVSS ⁽²⁾	0	3.3	AVDD	V
	Speaker impedance	Resistance applied across class-D output pins (BTL)	8			Ω
	Headphone impedance	AC coupled to R _L	16			Ω
V _I	Analog audio full-scale input voltage	AVDD = 3.3V, single-ended		0.707		V _{RMS}
	Stereo line output load impedance	AC coupled to R _L		10		kΩ
MCLK ⁽³⁾	Master clock frequency	IOVDD = 3.3V			50	MHz
SCLK	SCLK frequency	IOVDD = 3.3V			30	MHz
	SCLK duty cycle		40%	50%	60%	
SCL	SCL clock frequency				400	kHz
T _A	Operating free-air temperature		-40		85	°C

- (1) To minimize battery-current leakage, the SLVDD and SRVDD voltage levels should not be below the AVDD voltage level.
- (2) All grounds on board are tied together, so they should not differ in voltage by more than 0.2 V maximum for any combination of ground signals. By use of a wide trace or ground plane, ensure a low-impedance connection between HVSS and DVSS.
- (3) The maximum input frequency should be 50 MHz for any digital pin used as a general-purpose clock.

3.3 Electrical Characteristics

 At 25°C, AVDD, HVDD, IOVDD, TSVDD, = 3.3 V, SLVDD, SRVDD = 3.6V, DVDD = 1.8 V, VREF = 3.3 V, f_S (audio) = 48 kHz, CODEC_CLKIN = 256 × f_S, PLL = Off, SAR input is AUX1, VOL/MICDET pin disabled (unless otherwise noted)

PARAMETER	TEST CONDITIONS	MIN	TYP	MAX	UNIT
SAR CONVERTER					
Auxiliary Analog Input					
Input voltage range	AUX1, AUX2, VBAT input selected as input by touch screen	0		VREF	V
Input impedance ⁽¹⁾			1/(f×C)		kΩ
Input capacitance			25		pF
Input leakage current				1	
Input voltage range for VBAT	Battery-measurement mode	0		6	V

- (1) SAR input impedance is dependent on the sampling frequency, where the sampling capacitor is C = 25 pF.

Electrical Characteristics (continued)

At 25°C, AVDD, HVDD, IOVDD, TSVDD, = 3.3 V, SLVDD, SRVDD = 3.6V, DVDD = 1.8 V, VREF = 3.3 V, f_s (audio) = 48 kHz, CODEC_CLKIN = 256 × f_s , PLL = Off, SAR input is AUX1, VOL/MICDET pin disabled (unless otherwise noted)

PARAMETER	TEST CONDITIONS	MIN	TYP	MAX	UNIT	
Touch-Screen SAR ADC						
Resolution	Programmable: 8-bit, 10-bit, 12-bit	8		12	Bits	
No missing codes	12-bit resolution		11		Bits	
INL	Integral nonlinearity		±7		LSB	
	Offset error		±7		LSB	
	Gain error		±7		LSB	
	Noise		0.8		LSB	
Conversion Rate						
	Normal conversion operation	12 bits, internal conversion clock = 2 MHz		119	kHz	
	High-speed conversion operation	8 bits, internal conversion clock = 6 MHz (Conversion accuracy is reduced.)		250	kHz	
Voltage Reference—VREF						
Voltage range	Internal VREF	1.25		2.5	V	
	External VREF	1.25		AVDD		
Internal VREF output voltage	Measured with 1- μ F capacitor to analog ground. Internal VREF selected as 1.25 V (page 3/register 6, bit D6 = 0)		1.23		V	
INTERNAL OSCILLATOR—RC_CLK						
	Oscillator frequency for SAR		8.2		MHz	
VOLUME CONTROL PIN (ADC); VOL/MICDET pin enabled						
Input voltage range	VOL/MICDET pin configured as volume control (page 0/register 116, bit D7 = 1 and page 0/register 67, bit D7 = 0)	0		0.5 × AVDD	V	
Input capacitance			2		pF	
Volume control steps			128		Steps	
AUDIO ADC						
Microphone Input to ADC, 984-Hz Sine-Wave Input, f_s = 48 kHz, AGC = OFF						
	Input signal level (0-dB)	MIC with R1 = 20 k Ω (page 1/register 48 and register 49, bits D7–D6)		0.707	V_{RMS}	
SNR	Signal-to-noise ratio	f_s = 48 kHz, 0-dB PGA gain, MIC input ac-short to ground; measured as idle-channel noise, A-weighted ^{(1) (2)}		80	90	dB
	Dynamic range	f_s = 48 kHz, 0-dB PGA gain, MIC input 1 kHz at –60-dBFS input applied, referenced to 0.707-Vrms input, A-weighted ^{(1) (2)}			91	dB
THD+N	Total harmonic distortion + noise	f_s = 48 kHz, 0-dB PGA gain, MIC input 1 kHz at –2 dBFS input applied, referenced to 0.707 Vrms input		–83	–70	dB
THD	Total harmonic distortion	f_s = 48 kHz, 0-dB PGA gain, MIC input 1 kHz at –2 dBFS input applied, referenced to 0.707 Vrms input		–90		dB
	Input capacitance	MIC input		2	pF	

- (1) Ratio of output level with 1-kHz full-scale sine-wave input, to the output level with the inputs short-circuited, measured A-weighted over a 20-Hz to 20-kHz bandwidth using an audio analyzer.
- (2) All performance measurements done with 20-kHz low-pass filter and, where noted, A-weighted filter. Failure to use such a filter may result in higher THD+N and lower SNR and dynamic range readings than shown in the Electrical Characteristics. The low-pass filter removes out-of-band noise, which, although not audible, may affect dynamic specification values.

Electrical Characteristics (continued)

At 25°C, AVDD, HVDD, IOVDD, TSVDD, = 3.3 V, SLVDD, SRVDD = 3.6V, DVDD = 1.8 V, VREF = 3.3 V, f_S (audio) = 48 kHz, CODEC_CLKIN = 256 × f_S, PLL = Off, SAR input is AUX1, VOL/MICDET pin disabled (unless otherwise noted)

PARAMETER	TEST CONDITIONS	MIN	TYP	MAX	UNIT		
Microphone Bias							
Voltage output	Page 1/register 46, bits D1–D0 = 10	2.25	2.5	2.75	V		
	Page 1/register 46, bits D1–D0 = 01	2					
Voltage regulation	At 4-mA load current, page 1/register 46, bits D1–D0 = 10 (MICBIAS = 2.5 V)	5			mV		
	At 4-mA load current, page 1/register 46, bits D1–D0 = 01 (MICBIAS = 2 V)	7					
Audio ADC Digital Decimation Filter Characteristics							
See Section 5.5.4.4 for audio ADC decimation filter characteristics.							
DAC HEADPHONE OUTPUT, AC-coupled load = 16 Ω (single-ended), driver gain = 0 dB, parasitic capacitance = 30 pF							
Full-scale output voltage (0 dB)	Output common-mode setting = 1.65 V	0.707			V _{rms}		
SNR	Signal-to-noise ratio	80			95	dB	
THD	Total harmonic distortion	0-dBFS input			–85	–65	dB
THD+N	Total harmonic distortion + noise	0-dBFS input			–82	–60	dB
	Mute attenuation				87		dB
PSRR	Power-supply rejection ratio ⁽³⁾	Ripple on HVDD (3.3 V) = 200 mVp-p at 1 kHz			62		dB
P _O	Maximum output power	R _L = 32 Ω, THD+N ≤ –60 dB			20		mW
		R _L = 16 Ω, THD+N ≤ –60 dB			60		
DAC LINEOUT (HP Driver in Lineout Mode)							
SNR	Signal-to-noise ratio	Measured as idle-channel noise, A-weighted			95		dB
THD	Total harmonic distortion	0-dBFS input, 0-dB gain			–86		dB
THD+N	Total harmonic distortion + noise	0-dBFS input, 0-dB gain			–82		dB
DAC Digital Interpolation Filter Characteristics							
See Section 5.6.1.4 for DAC interpolation filter characteristics.							
DAC OUTPUT to CLASS-D SPEAKER OUTPUT; Load = 8 Ω (differential), 50 pF							
Output voltage	SLVDD = SRVDD = 3.6 V, BTL measurement, DAC input = 0 dBFS, DAC VCM (page 1/register 31, bits D4–D3) = 1.65 V, class-D gain = 6 dB, THD ≤ –16.5 dB	2.2			V _{rms}		
	SLVDD = SRVDD = 3.6 V, BTL measurement, DAC input = –2 dBFS, DAC VCM (page 1/register 31, bits D4–D3) = 1.65 V, class-D gain = 6 dB, THD ≤ –20 dB	2.1					
Output, common-mode	SLVDD = SRVDD = 3.6 V, BTL measurement, DAC input = mute, DAC VCM (page 1/register 31, bits D4–D3) = 1.65 V, class-D gain = 6 dB	1.65			V		
SNR	Signal-to-noise ratio	SLVDD = SRVDD = 3.6 V, BTL measurement, class-D gain = 6 dB, measured as idle-channel noise, A-weighted (with respect to full-scale output value of 2.2 V _{rms}) ^{(1) (2)}			87		dB

(1) Ratio of output level with 1-kHz full-scale sine-wave input, to the output level with the inputs short-circuited, measured A-weighted over a 20-Hz to 20-kHz bandwidth using an audio analyzer.

(2) All performance measurements done with 20-kHz low-pass filter and, where noted, A-weighted filter. Failure to use such a filter may result in higher THD+N and lower SNR and dynamic range readings than shown in the Electrical Characteristics. The low-pass filter removes out-of-band noise, which, although not audible, may affect dynamic specification values.

$$PSRR = 20 \log_{10} \left[\frac{V_{SIG_{Supp}}}{V_{DACOUT}} \right]$$

(3) DAC to headphone-out PSRR measurement is calculated as

Electrical Characteristics (continued)

At 25°C, AVDD, HVDD, IOVDD, TSVDD, = 3.3 V, SLVDD, SRVDD = 3.6V, DVDD = 1.8 V, VREF = 3.3 V, f_s (audio) = 48 kHz, CODEC_CLKIN = 256 × f_s , PLL = Off, SAR input is AUX1, VOL/MICDET pin disabled (unless otherwise noted)

PARAMETER		TEST CONDITIONS	MIN	TYP	MAX	UNIT
DAC OUTPUT to CLASS-D SPEAKER OUTPUT; Load = 8 Ω (differential), 50 pF (continued)						
THD	Total harmonic distortion	SLVDD = SRVDD = 3.6 V, BTL measurement, DAC input = -6 dBFS, DAC VCM (page 1/register 31, bits D4–D3) = 1.65 V, class-D gain = 6 dB		-72		dB
THD+N	Total harmonic distortion + noise	SLVDD = SRVDD = 3.6 V, BTL measurement, DAC input = -6 dBFS, DAC VCM (page 1/register 31, bits D4–D3) = 1.65 V, class-D gain = 6 dB		-71		dB
PSRR	Power-supply rejection ratio ⁽¹⁾	SLVDD = SRVDD = 3.6 V, BTL measurement, ripple on SLVDD/SRVDD = 200 mVp-p at 1 kHz		57		dB
	Mute attenuation			110		dB
P _O	Maximum output power	SLVDD = SRVDD = 3.6 V, BTL measurement, DAC VCM (page 1/register 31, bits D4–D3) = 1.65 V, class-D gain = 18 dB, THD = 10%		540		mW
		SLVDD = SRVDD = 4.3 V, BTL measurement, DAC VCM (page 1/register 31, bits D4–D3) = 1.65 V, class-D gain = 18 dB, THD = 10%		790		
		SLVDD = SRVDD = 5.5 V, BTL measurement, DAC VCM (page 1/register 31, bits D4–D3) = 1.65 V, class-D gain = 18 dB, THD = 10%		1.29		W
	Output-stage leakage current for direct battery connection	SLVDD = SRVDD = 4.3 V, device is powered down (power-up-reset condition)		80		nA
ADC and DAC POWER CONSUMPTION						
For ADC and DAC power consumption based per selected processing block, see Section 5.4						
DIGITAL INPUT/OUTPUT						
Logic family			CMOS			
V _{IH}	Logic level	I _{IH} = 5 μA, IOVDD ≥ 1.6 V	0.7 × IOVDD		V	
		I _{IH} = 5 μA, IOVDD < 1.6 V	IOVDD			
V _{IL}		I _{IL} = 5 μA, IOVDD ≥ 1.6 V	-0.3	0.3 × IOVDD		V
		I _{IL} = 5 μA, IOVDD < 1.6 V	0			
V _{OH}		I _{OH} = 2 TTL loads	0.8 × IOVDD		V	
V _{OL}		I _{OL} = 2 TTL loads			0.1 × IOVDD	V
	Capacitive load		10		pF	

(1) DAC to speaker-out PSRR measurement is calculated as

$$PSRR = 20 \log_{10} \left[\frac{V_{SIG_{Supp}}}{V_{SPK1/2}} \right]$$

3.4 Timing Characteristics

3.4.1 I²S/LJF/RJF Timing in Master Mode

All specifications at 25°C, DVDD = 1.8 V

Note: All timing specifications are measured at characterization but not tested at final test.

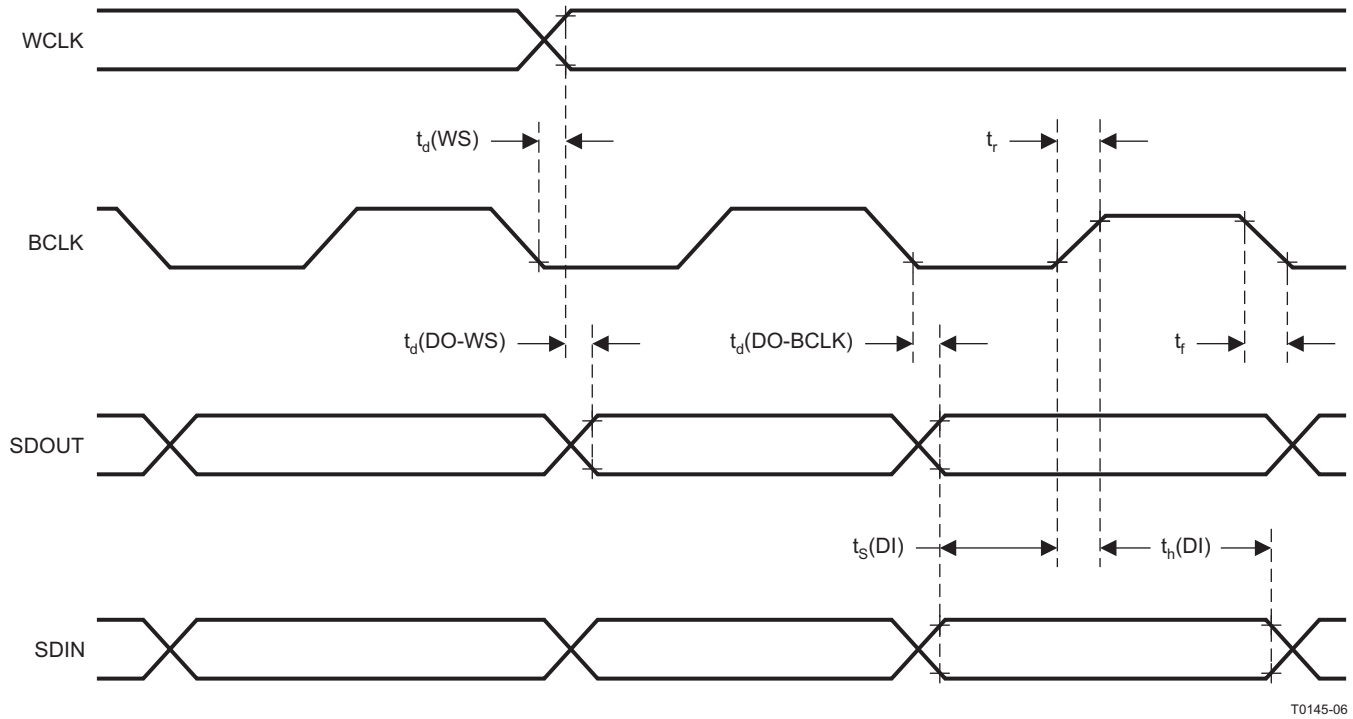

T0145-06

PARAMETER		IOVDD = 1.1 V		IOVDD = 3.3 V		UNITS
		MIN	MAX	MIN	MAX	
$t_d(WS)$	WCLK delay		45		20	ns
$t_d(DO-WS)$	WCLK to DOUT delay (for LJF mode only)		45		20	ns
$t_d(DO-BCLK)$	BCLK to DOUT delay		45		20	ns
$t_s(DI)$	SDIN setup	8		6		ns
$t_h(DI)$	SDIN hold	8		6		ns
t_r	Rise time		25		10	ns
t_f	Fall time		25		10	ns

Figure 3-1. I²S/LJF/RJF Timing in Master Mode

3.4.2 I²S/LJF/RJF Timing in Slave Mode

All specifications at 25°C, DVDD = 1.8 V

Note: All timing specifications are measured at characterization but not tested at final test.

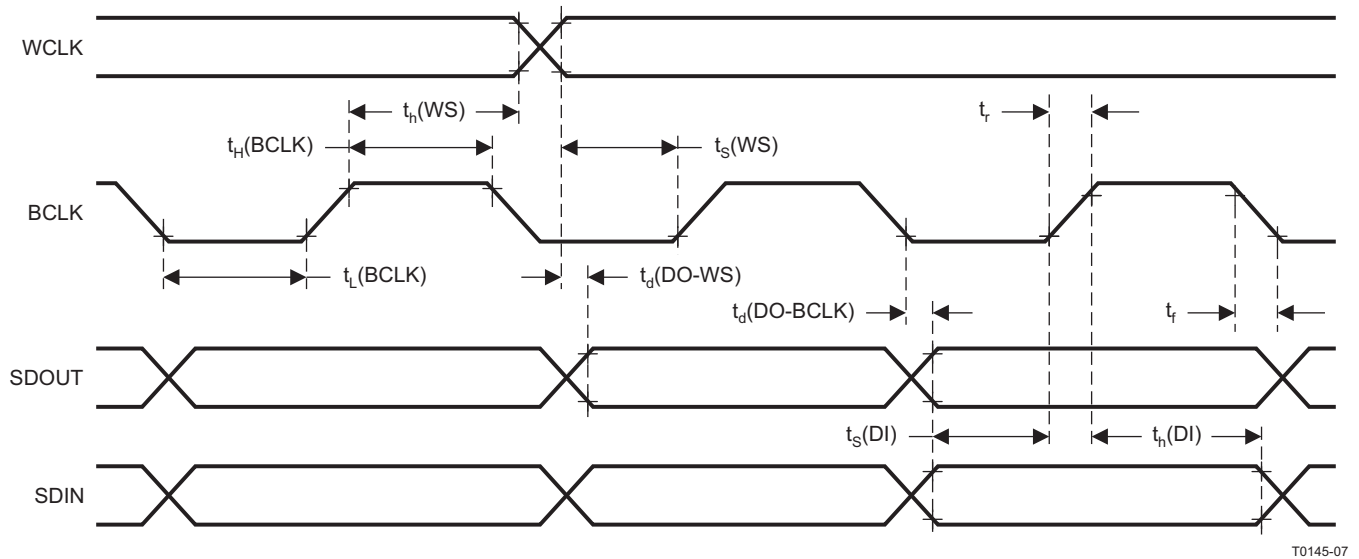

PARAMETER		IOVDD = 1.1 V		IOVDD = 3.3 V		UNIT
		MIN	MAX	MIN	MAX	
$t_H(\text{BCLK})$	BCLK high period	35		35		ns
$t_L(\text{BCLK})$	BCLK low period	35		35		ns
$t_S(\text{WS})$	WCLK setup	8		6		ns
$t_H(\text{WS})$	WCLK hold	8		6		ns
$t_D(\text{DO-WS})$	WCLK to DOUT delay (for LJF mode only)		45		20	ns
$t_D(\text{DO-BCLK})$	BCLK to DOUT delay		45		20	ns
$t_S(\text{DI})$	SDIN setup	8		6		ns
$t_H(\text{DI})$	SDIN hold	8		6		ns
t_r	Rise time		4		4	ns
t_f	Fall time		4		4	ns

Figure 3-2. I²S/LJF/RJF Timing in Slave Mode

3.4.3 DSP Timing in Master Mode

All specifications at 25°C, DVDD = 1.8 V

Note: All timing specifications are measured at characterization but not tested at final test.

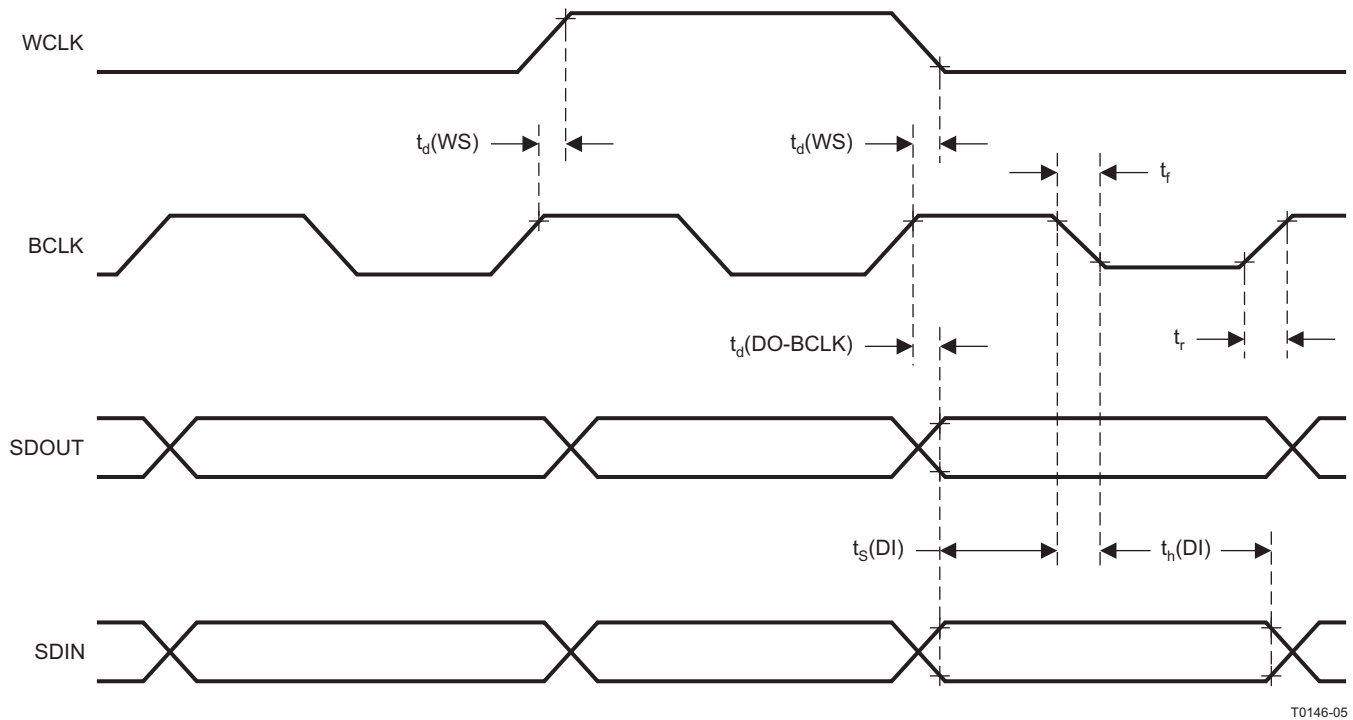

T0146-05

PARAMETER		IOVDD = 1.1 V		IOVDD = 3.3 V		UNITS
		MIN	MAX	MIN	MAX	
$t_d(WS)$	WCLK delay		45		20	ns
$t_d(DO-BCLK)$	BCLK to DOUT delay		45		20	ns
$t_s(DI)$	SDIN setup	8		8		ns
$t_h(DI)$	SDIN hold	8		8		ns
t_r	Rise time		25		10	ns
t_f	Fall time		25		10	ns

Figure 3-3. DSP Timing in Master Mode

3.4.4 DSP Timing in Slave Mode

All specifications at 25°C, DVDD = 1.8 V

Note: All timing specifications are measured at characterization but not tested at final test.

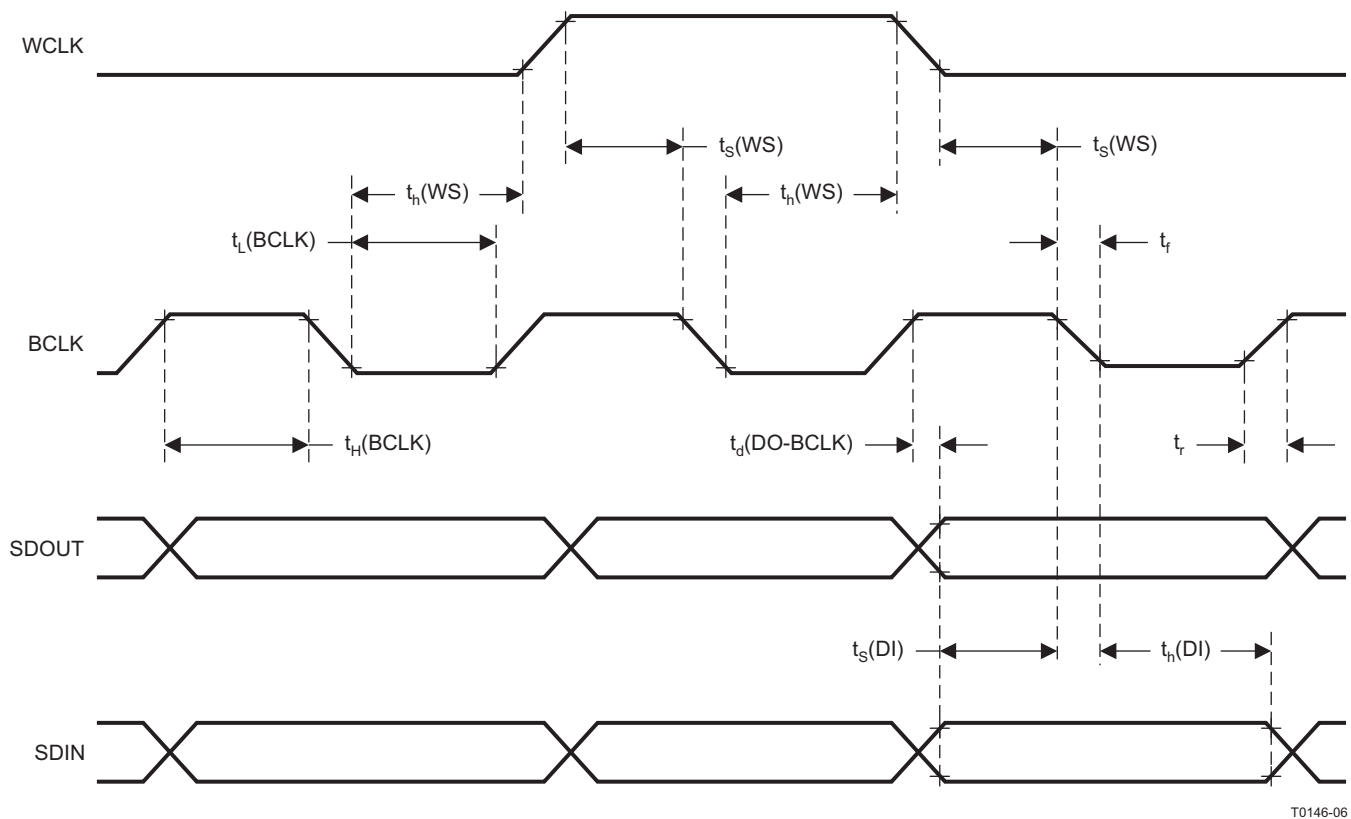

PARAMETER		IOVDD = 1.1 V		IOVDD = 3.3 V		UNITS
		MIN	MAX	MIN	MAX	
$t_H(\text{BCLK})$	BCLK high period	35		35		ns
$t_L(\text{BCLK})$	BCLK low period	35		35		ns
$t_S(\text{WS})$	WCLK setup	8		8		ns
$t_H(\text{WS})$	WCLK hold	8		8		ns
$t_d(\text{DO-BCLK})$	BCLK to DOUT delay		45		20	ns
$t_S(\text{DI})$	SDIN setup	8		8		ns
$t_H(\text{DI})$	SDIN hold	8		8		ns
t_r	Rise time		4		4	ns
t_f	Fall time		4		4	ns

Figure 3-4. DSP Timing in Slave Mode

3.4.5 I²C Interface Timing

All specifications at 25°C, DVDD = 1.8 V

Note: All timing specifications are measured at characterization but not tested at final test.

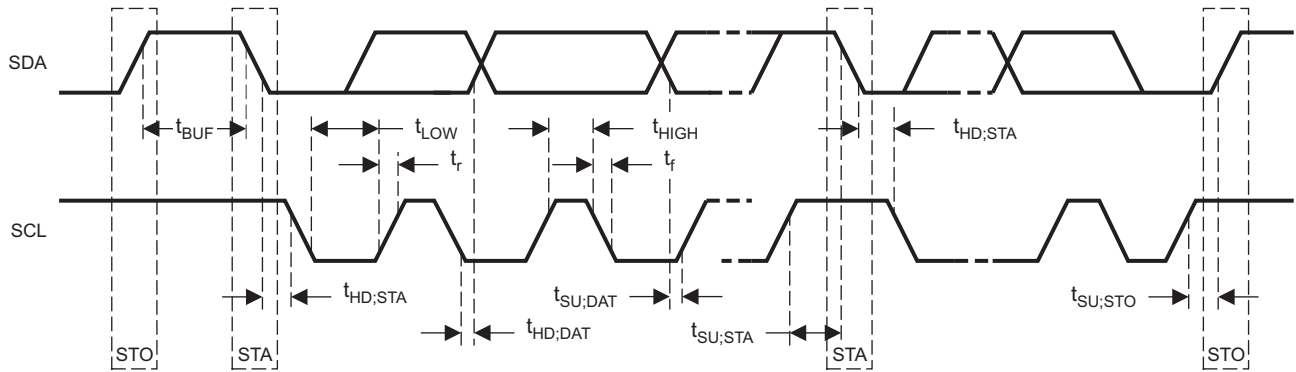

T0295-02

PARAMETER	Standard-Mode			Fast-Mode			UNITS
	MIN	TYP	MAX	MIN	TYP	MAX	
f _{SCL}	SCL clock frequency		0	100	0	400	kHz
t _{HD;STA}	Hold time (repeated) START condition. After this period, the first clock pulse is generated.		4.0		0.8		μs
t _{LOW}	LOW period of the SCL clock		4.7		1.3		μs
t _{HIGH}	HIGH period of the SCL clock		4.0		0.6		μs
t _{SU;STA}	Setup time for a repeated START condition		4.7		0.8		μs
t _{HD;DAT}	Data hold time: For I ² C bus devices		0	3.45	0	0.9	μs
t _{SU;DAT}	Data set-up time		250		100		ns
t _r	SDA and SCL Rise Time			1000	20 + 0.1C _b	300	ns
t _f	SDA and SCL Fall Time			300	20 + 0.1C _b	300	ns
t _{SU;STO}	Set-up time for STOP condition		4.0		0.8		μs
t _{BUF}	Bus free time between a STOP and START condition		4.7		1.3		μs
C _b	Capacitive load for each bus line			400		400	pF

Figure 3-5. I²C Interface Timing

3.4.6 SPI Interface Timing

All specifications at 25°C, DVDD = 1.8 V

Note: All timing specifications are measured at characterization but not tested at final test.

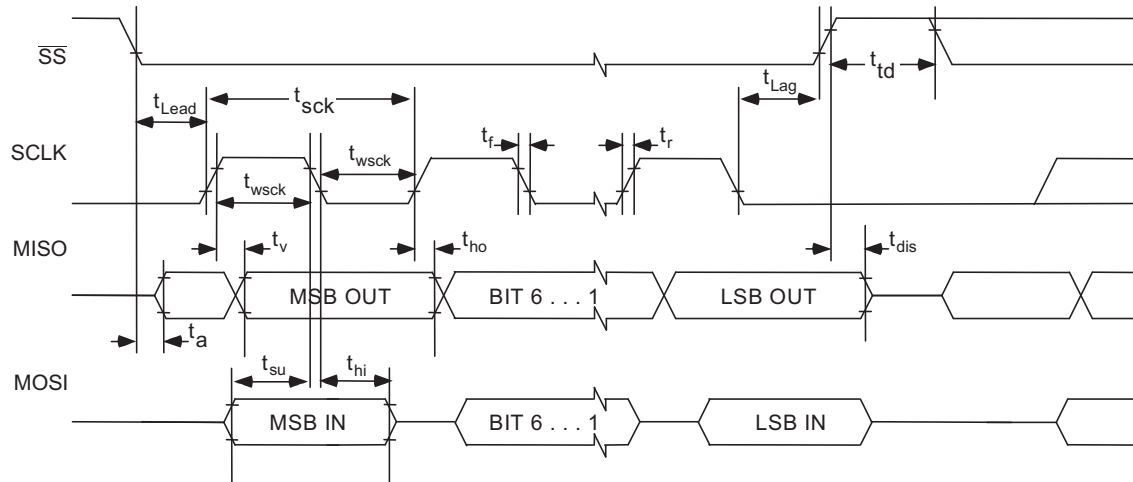

PARAMETER	IOVDD = 1.1 V		IOVDD = 3.3 V		UNITS	
	MIN	MAX	MIN	MAX		
t_{w_sck}	SCLK pulse duration	50			ns	
t_{Lead}	Enable lead time	50	20		ns	
t_{Lag}	Enable lag time	50	20		ns	
t_{td}	Sequential transfer delay	40	20		ns	
t_a	MISO slave data-out access time			40	20	ns
t_{dis}	MISO slave data-out disable time			40	20	ns
t_{su}	MOSI data-in setup time	15	10			ns
t_{hi}	MOSI data-in hold time	15	10			ns
t_v	MISO data-valid time		25		18	ns
t_r	SCLK rise time			4		ns
t_f	SCLK fall time			4		ns

Figure 3-6. SPI Interface Timing Diagram

4 TYPICAL PERFORMANCE

4.1 Audio ADC Performance

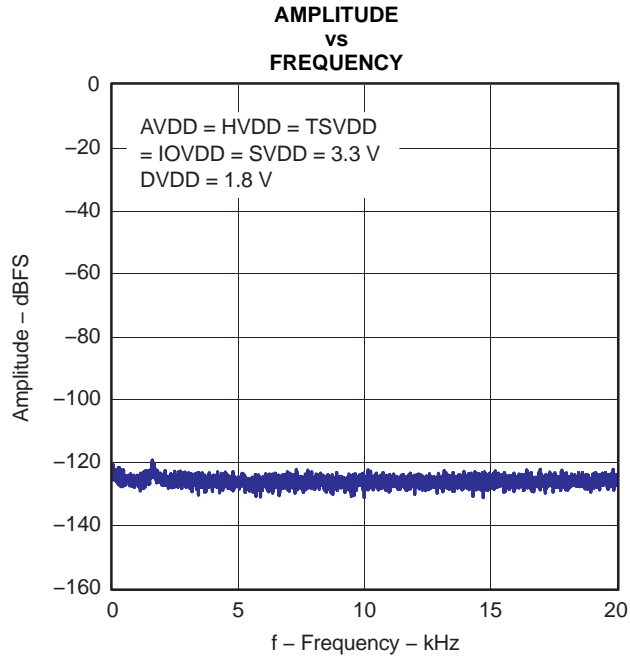

Figure 4-1. FFT - ADC Idle Channel Differential

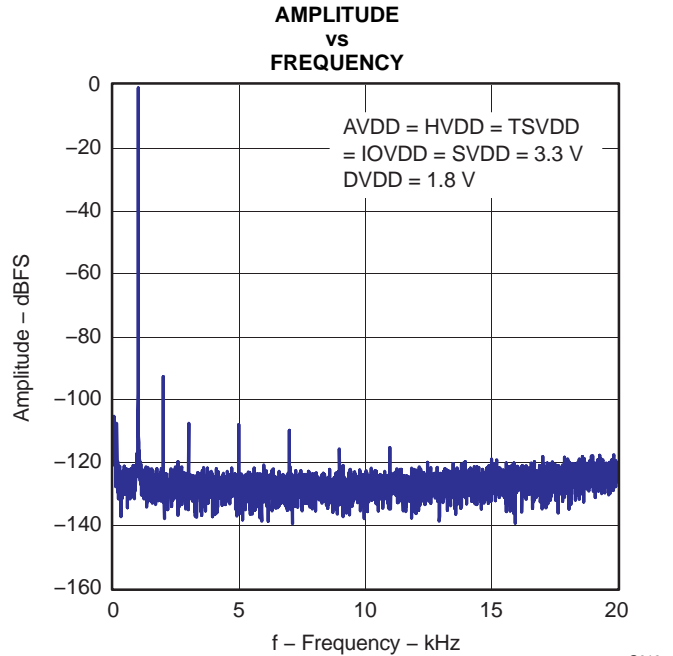

Figure 4-2. FFT - ADC Single-Ended Input

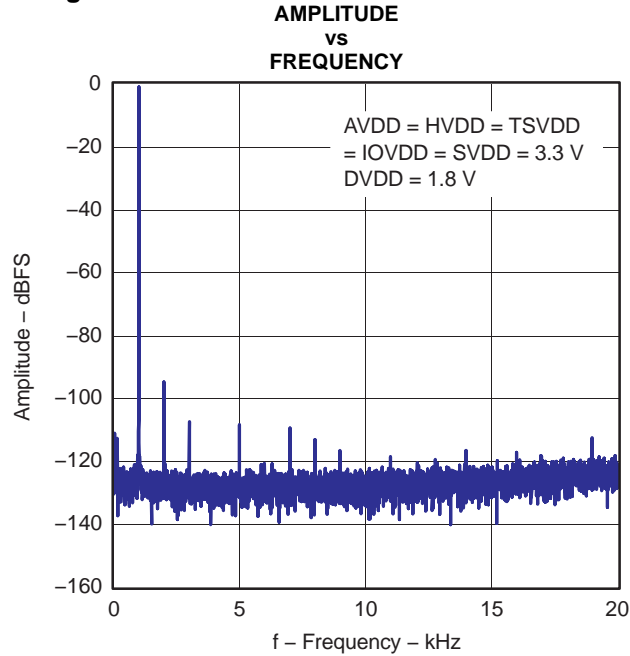

Figure 4-3. FFT - ADC Differential Input

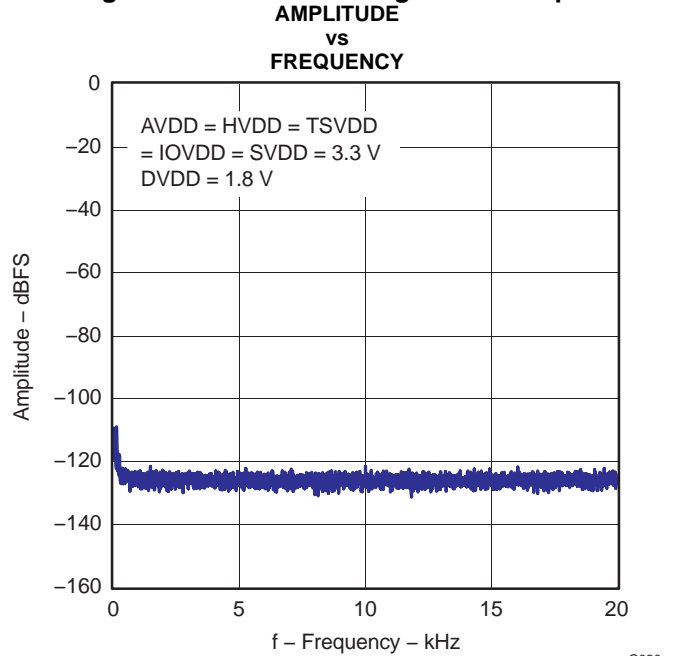

Figure 4-4. FFT - ADC Idle Channel Single-Ended

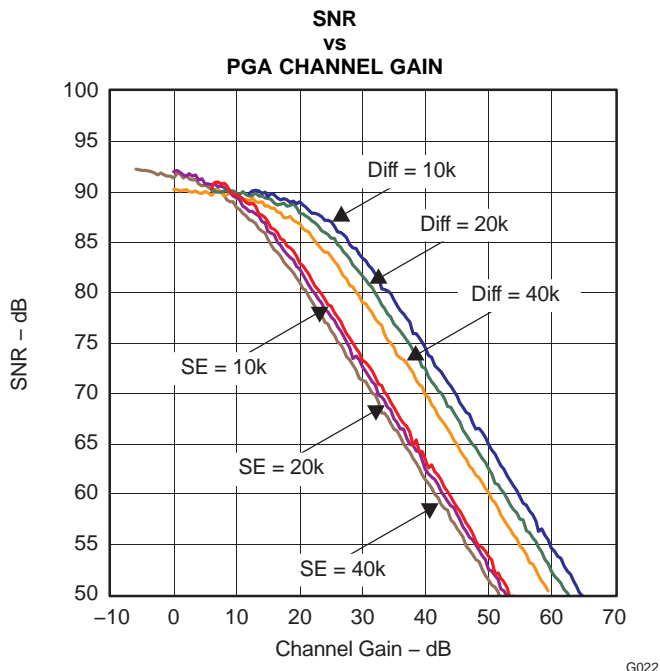

Figure 4-5.

4.2 DAC Performance

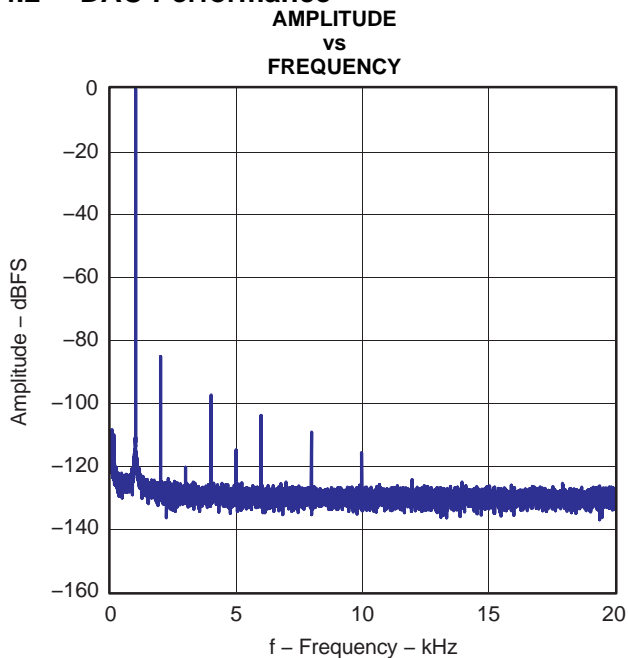

Figure 4-6. FFT - DAC to Line Output

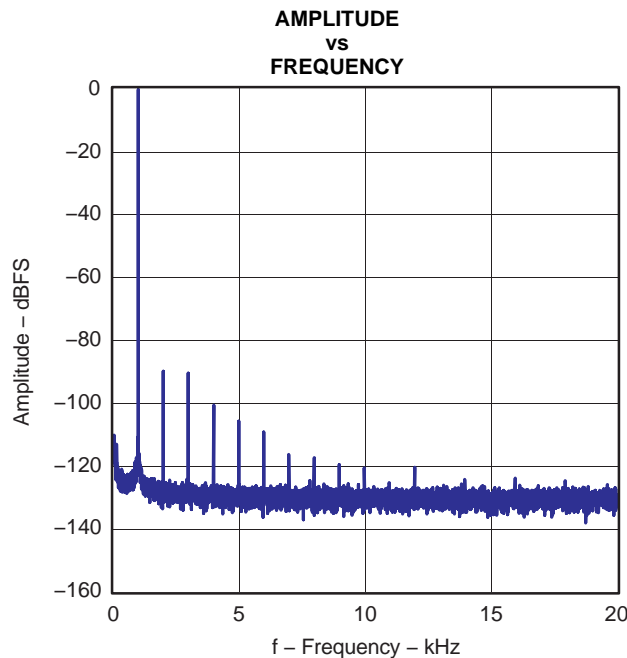

Figure 4-7. FFT - DAC to Headphone Output

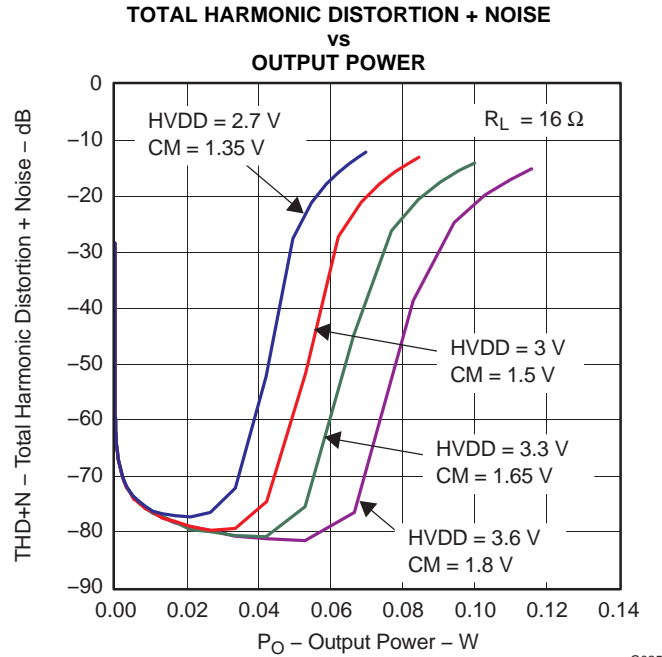

Figure 4-8. Headphone Output Power (R_L = 16 Ω)

4.3 Class-D Speaker Driver Performance

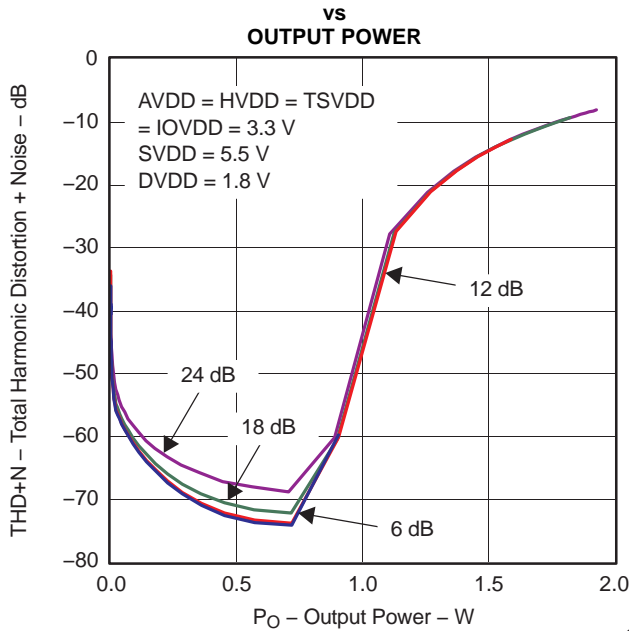

Figure 4-9. Max Class-D Speaker-Driver Output Power (R_L = 8 Ω, Driver Gain = 6 dB to 24 dB)

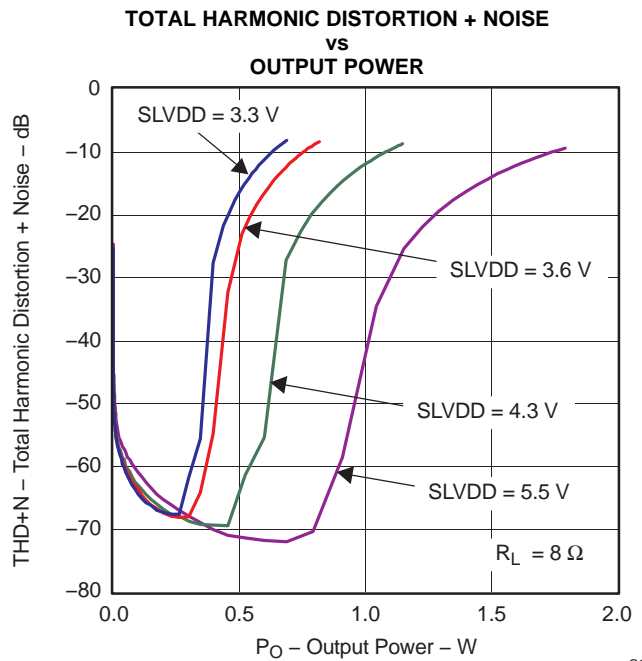

Figure 4-10. Class-D Speaker-Driver Output Power (R_L = 8 Ω, SLVDD = 3.3 V to 5.5V, Driver Gain = 18 dB)

4.4 Analog Bypass Performance

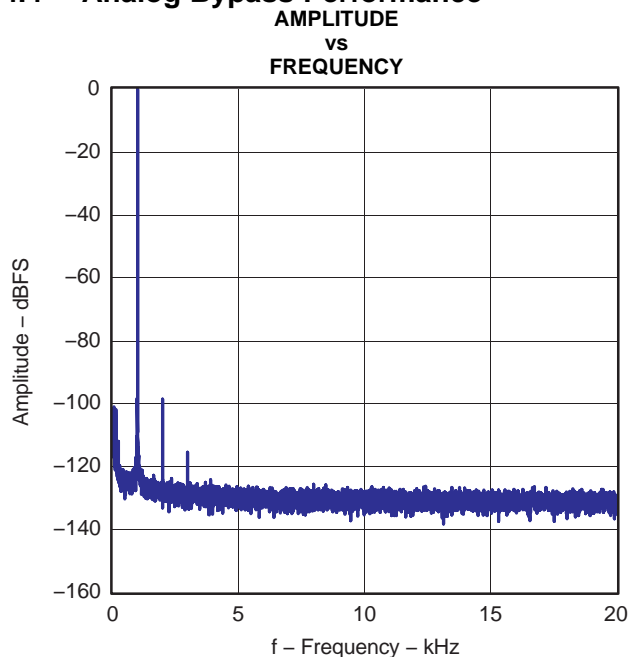

Figure 4-11. FFT - Line In Bypass to Line Output

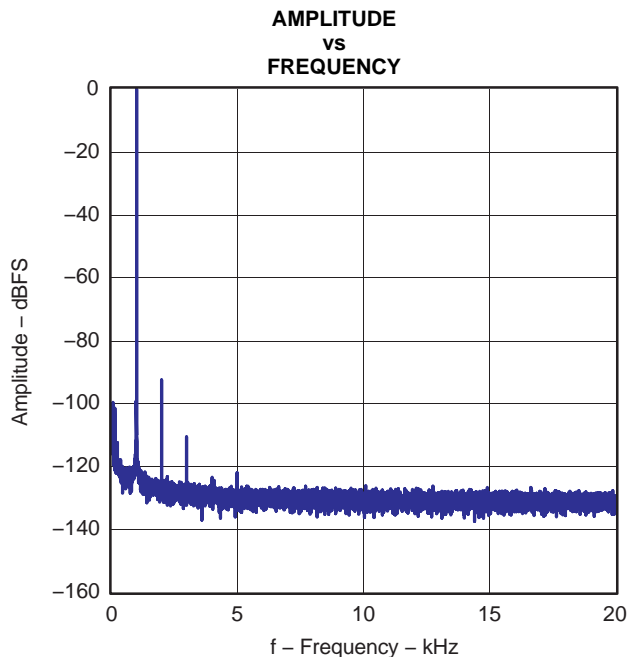

Figure 4-12. FFT - Line In Bypass to Headphone Output

4.5 MICBIAS Performance

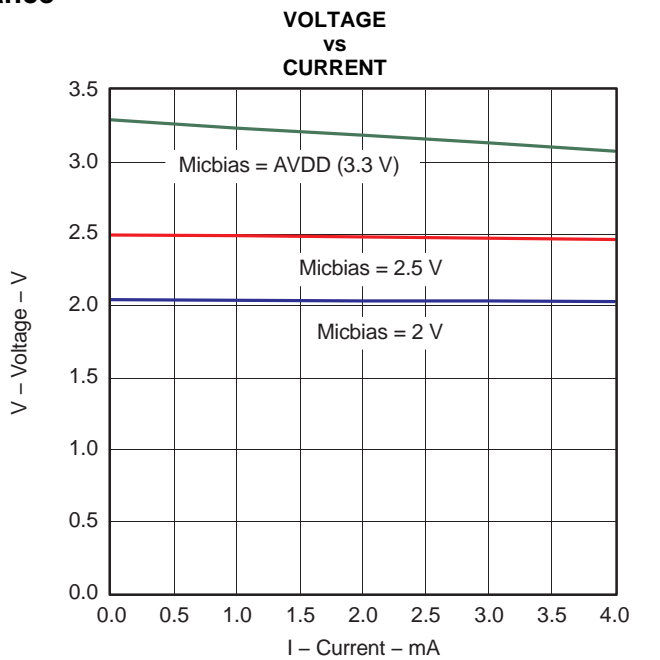

Figure 4-13. Micbias

5 APPLICATION INFORMATION

5.1 Typical Circuit Configuration

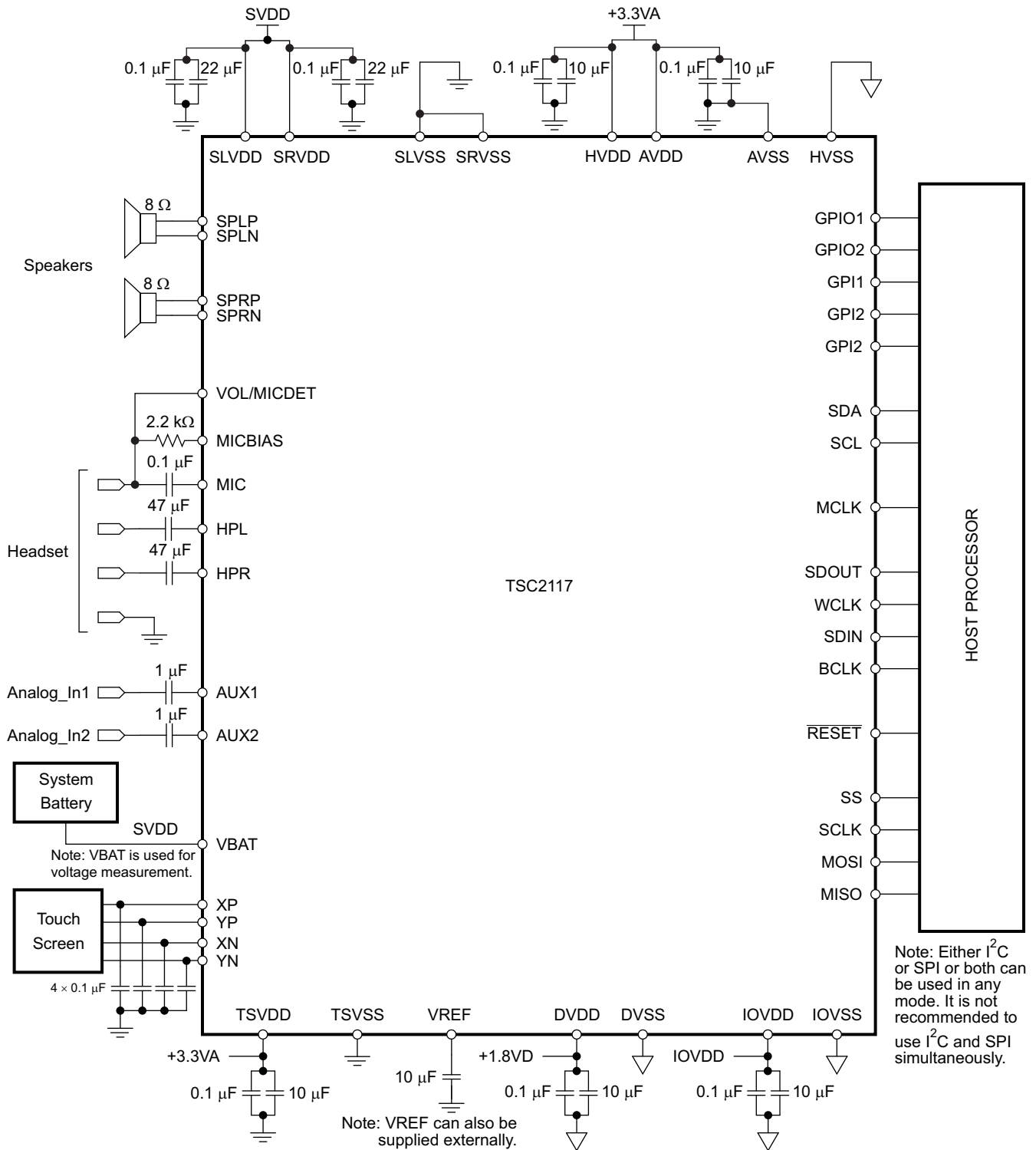

Figure 5-1. Typical Circuit Configuration

S0400-01

5.2 Overview

The TSC2117 is a highly integrated stereo audio DAC and monaural ADC with touch-screen controller for portable computing, communication, and entertainment applications. A register-based architecture eases integration with microprocessor-based systems through standard serial-interface buses. This device supports the four-wire SPI bus and the 2-wire I²C bus interfaces. The I²C interface and the SPI interface provide full register access. The SPI data bus can be used for higher-speed communication and for high-speed retrieval of SAR ADC data. All peripheral functions are controlled through these registers and the onboard state machines.

The TSC2117 consists of the following blocks:

- Touch-panel drivers
- Microphone interfaces (analog and digital)
- Audio codec (mono ADC and stereo DAC)
- AGC and DRC
- Two miniDSP digital signal-processing blocks (record and playback paths)
- Beep generator
- Stereo headphone/lineout amplifier
- Class-D stereo amplifier for 8-Ω speakers
- Pin-controlled or register-controlled volume level
- Power-down de-pop and power-up soft start
- SAR ADC for touch-panel, voltage, and temperature measurements
- FIFO buffer mode for SAR auxiliary and touch-screen data
- Auxiliary inputs
- SPI control interface
- I²C control interface
- Power-down control block

Following a toggle of the $\overline{\text{RESET}}$ pin or a software reset, the device operates in the default mode. The SPI or I²C interface can be used to write to the control registers to configure the device.

The I²C address assigned to the TSC2117 is 001 1000. This device always operates in an I²C slave mode. All registers are 8-bit, and all writable registers have read-back capability. The device auto-increments to support sequential addressing and can be used with I²C fast mode. Once the device is reset, all appropriate registers are updated by the host processor to configure the device as needed by the user.

SAR ADC data is transferred through the SPI/I²C bus, and audio data (for audio ADC and DAC) is transferred through the audio serial interface. The SPI interface requires that the $\overline{\text{SS}}$ signal be driven low to communicate with the TSC2117. Data is then shifted into or out of the TSC2117 under control of the host microprocessor, which also provides the SPI serial clock.

5.2.1 Device Initialization

5.2.1.1 Reset

The TSC2117 internal logic must be initialized to a known condition for proper device function. To initialize the device to its default operating condition, the hardware reset pin ($\overline{\text{RESET}}$) must be pulled low for at least 10 ns. For this initialization to work, both the IOVDD and DVDD supplies must be powered up. It is recommended that while the DVDD supply is being powered up, the $\overline{\text{RESET}}$ pin be pulled low.

The device can also be reset via software reset. Writing a 1 into page 0/register 1, bit D0 resets the device.

5.2.1.2 Device Start-Up Lockout Times

After the TSC2117 is initialized through hardware reset at power-up or software reset, the internal memories are initialized to default values. This initialization takes place within 1 ms after pulling the $\overline{\text{RESET}}$ signal high. During this initialization phase, no register-read or register-write operation should be performed on ADC or DAC coefficient buffers. Also, no block within the codec should be powered up during the initialization phase.

5.2.1.3 PLL Start-Up

Whenever the PLL is powered up, a start-up delay of approximately of 10 ms occurs after the power-up command of the PLL and before the clocks are available to the codec. This delay is to ensure stable operation of the PLL and clock-divider logic.

5.2.1.4 Power-Stage Reset

The power-stage-only reset is used to reset the device after an overcurrent latching shutdown has occurred. Using this reset re-enables the output stage without resetting all of the registers in the device. Each of the four power stages has its own dedicated reset bit. The headphone power-stage reset is performed by setting page 1/register 31, bit D7 for HPL and by setting page 1/register 31, bit D6 for HPR. The speaker power-stage reset is performed by setting page 1/register 32, bit D7 for SPLP and SPLN, and by setting page 1/register 32, bit D6 for SPRP and SPRN.

5.2.1.5 Software Power Down

By default, all circuit blocks are powered down following a reset condition. Hardware power up of each circuit block can be controlled by writing to the appropriate control register. This approach allows the lowest power-supply current for the functionality required. However, when a block is powered down, all of the register settings are maintained as long as power is still being applied to the device. The TSC2117 touch-detection circuitry is enabled by default, and it can be powered down by writing to page 3/register 4, bit D7.

5.2.2 Audio Analog I/O

The TSC2117 has a stereo audio DAC and a monaural ADC. It supports a wide range of analog interfaces to support different headsets and analog outputs. The TSC2117 has features to interface output drivers (8- Ω , 16- Ω , 32- Ω) and a microphone PGA with AGC control. A special circuit has also been included in the TSC2117 to insert a short key-click sound into the stereo audio output. The key-click sound is used to provide feedback to the user when a particular button is pressed or item is selected. The specific sound of the keyclick can be adjusted by varying several register bits that control its frequency, duration, and amplitude. See *Key-Click Functionality With Beep Generator*, [Section 5.6.5](#).

5.3 miniDSP

The TSC2117 features two miniDSP cores. The first miniDSP core is tightly coupled to the ADC; the second miniDSP core is tightly coupled to the DAC. The fully programmable algorithms for the miniDSP must be loaded into the device after power up. The miniDSPs have direct access to the digital stereo audio stream on the ADC and on the DAC side, offering the possibility for advanced, very low-group-delay DSP algorithms.

The ADC miniDSP has 384 programmable instructions, 256 data memory locations, and 128 programmable coefficients. The DAC miniDSP has 1024 programmable instructions, 896 data memory locations, and 512 programmable coefficients (in the adaptive mode, each bank has 256 programmable coefficients).

5.3.1 Software

Software development for the TSC2117 is supported through TI's comprehensive PurePath™ Studio software development environment, a powerful, easy-to-use tool designed specifically to simplify software development on Texas Instruments miniDSP audio platforms. The graphical development environment consists of a library of common audio functions that can be dragged and dropped into an audio signal flow and graphically connected together. The DSP code can then be assembled from the graphical signal flow with the click of a mouse.

See the TSC2117 product folder on www.ti.com to learn more about PurePath Studio and the latest status on available, ready-to-use DSP algorithms.

5.4 Digital Processing Low-Power Modes

The TSC2117 device can be tuned to minimize power dissipation, to maximize performance, or to an operating point between the two extremes to best fit the application. The choice of processing blocks, PRB_P1 to PRB_P25 for stereo playback and PRB_R4 to PRB_R18 for mono recording, also influences the power consumption. In fact, the numerous processing blocks have been implemented to offer a choice among configurations having a different balance of power-optimization and signal-processing capabilities.

5.4.1 ADC, Mono, 48 kHz, DVDD = 1.8 V, AVDD = 3.3 V

AOSR = 128, Processing Block = PRB_R4 (Decimation Filter A)

Power consumption = 9.01 mW

Table 5-1. PRB_R4 Alternative Processing Blocks, 9.01 mW

Processing Block	Filter	Estimated Power Change (mW)
PRB_R5	A	0.23
PRB_R6	A	0.22

AOSR = 64, Processing Block = PRB_R11 (Decimation Filter B)

Power consumption = 7.99 mW

Table 5-2. PRB_R11 Alternative Processing Blocks, 7.99 mW

Processing Block	Filter	Estimated Power Change (mW)
PRB_R4	A	0.43
PRB_R5	A	0.67
PRB_R6	A	0.66
PRB_R10	B	-0.14
PRB_R12	B	0.04

5.4.2 ADC, Mono, 8 kHz, DVDD = 1.8 V, AVDD = 3.3 V

AOSR = 128, Processing Block = PRB_R4 (Decimation Filter A)

Power consumption = 6.77 mW

Table 5-3. PRB_R4 Alternative Processing Blocks, 6.77 mW

Processing Block	Filter	Estimated Power Change (mW)
PRB_R5	A	0.03
PRB_R6	A	0.03

AOSR = 64, Processing Block = PRB_R11 (Decimation Filter B)

Power consumption = 6.61 mW

Table 5-4. PRB_R11 Alternative Processing Blocks, 6.61 mW

Processing Block	Filter	Estimated Power Change (mW)
PRB_R4	A	0.07
PRB_R5	A	0.11
PRB_R6	A	0.11
PRB_R10	B	-0.02
PRB_R12	B	0.01

5.4.3 DAC Playback on Headphones, Stereo, 48 kHz, DVDD = 1.8 V, AVDD = 3.3 V, HVDD = 3.3 V

DOSR = 128, Processing Block = PRB_P7 (Interpolation Filter B)

Power consumption = 24.28 mW

Table 5-5. PRB_P7 Alternative Processing Blocks, 24.28 mW

Processing Block	Filter	Estimated Power Change (mW)
PRB_P1	A	1.34
PRB_P2	A	2.86
PRB_P3	A	2.11
PRB_P8	B	1.18
PRB_P9	B	0.53
PRB_P10	B	1.89
PRB_P11	B	0.87
PRB_P23	A	1.48
PRB_P24	A	2.89
PRB_P25	A	3.23

DOSR = 64, Processing Block = PRB_P7 (Interpolation Filter B)

Power consumption = 24.5 mW

Table 5-6. PRB_P7 Alternative Processing Blocks, 24.5 mW

Processing Block	Filter	Estimated Power Change (mW)
PRB_P1	A	1.17
PRB_P2	A	2.62
PRB_P3	A	2
PRB_P8	B	0.99
PRB_P9	B	0.5
PRB_P10	B	1.46
PRB_P11	B	0.66
PRB_P23	A	1.43
PRB_P24	A	2.69
PRB_P25	A	2.92

5.4.4 DAC Playback on Headphones, Mono, 48 kHz, DVDD = 1.8 V, AVDD = 3.3 V, HVDD = 3.3 V

DOSR = 128, Processing Block = PRB_P12 (Interpolation Filter B)

Power consumption = 15.4 mW

Table 5-7. PRB_P12 Alternative Processing Blocks, 15.4 mW

Processing Block	Filter	Estimated Power Change (mW)
PRB_P4	A	0.57
PRB_P5	A	1.48
PRB_P6	A	1.08
PRB_P13	B	0.56
PRB_P14	B	0.27
PRB_P15	B	0.89
PRB_P16	B	0.31

DOSR = 64, Processing Block = PRB_P12 (Interpolation Filter B)

Power consumption = 15.54 mW

Table 5-8. PRB_P12 Alternative Processing Blocks, 15.54 mW

Processing Block	Filter	Estimated Power Change (mW)
PRB_P4	A	0.37
PRB_P5	A	1.23
PRB_P6	A	1.15
PRB_P13	B	0.43
PRB_P14	B	0.13
PRB_P15	B	0.85
PRB_P16	B	0.21

5.4.5 DAC Playback on Headphones, Stereo, 8 kHz, DVDD = 1.8 V, AVDD = 3.3 V, HVDD = 3.3 V

DOSR = 768, Processing Block = PRB_P7 (Interpolation Filter B)

Power consumption = 22.44 mW

Table 5-9. PRB_P7 Alternative Processing Blocks, 22.44 mW

Processing Block	Filter	Estimated Power Change (mW)
PRB_P1	A	0.02
PRB_P2	A	0.31
PRB_P3	A	0.23
PRB_P8	B	0.28
PRB_P9	B	-0.03
PRB_P10	B	0.14
PRB_P11	B	0.05
PRB_P23	A	0.29
PRB_P24	A	0.26
PRB_P25	A	0.47

DOSR = 384, Processing Block = PRB_P7 (Interpolation Filter B)

Power consumption = 22.83 mW

Table 5-10. PRB_P7 Alternative Processing Blocks, 22.83 mW

Processing Block	Filter	Estimated Power Change (mW)
PRB_P1	A	0.27
PRB_P2	A	0.4
PRB_P3	A	0.34
PRB_P8	B	0.2
PRB_P9	B	0.08
PRB_P10	B	0.24
PRB_P11	B	0.12
PRB_P23	A	0.23
PRB_P24	A	0.42
PRB_P25	A	0.46

5.4.6 DAC Playback on Headphones, Mono, 8 kHz, DVDD = 1.8 V, AVDD = 3.3 V, HVDD = 3.3 V

DOSR = 768, Processing Block = PRB_P12 (Interpolation Filter B)

Power consumption = 14.49 mW

Table 5-11. PRB_P12 Alternative Processing Blocks, 14.49 mW

Processing Block	Filter	Estimated Power Change (mW)
PRB_P4	A	-0.04
PRB_P5	A	0.2
PRB_P6	A	-0.01
PRB_P13	B	0.1
PRB_P14	B	0.05
PRB_P15	B	-0.03
PRB_P16	B	0.07

DOSR = 384, Processing Block = PRB_P12 (Interpolation Filter B)

Power consumption = 14.42 mW

Table 5-12. PRB_P12 Alternative Processing Blocks, 14.42 mW

Processing Block	Filter	Estimated Power Change (mW)
PRB_P4	A	0.16
PRB_P5	A	0.3
PRB_P6	A	0.2
PRB_P13	B	0.15
PRB_P14	B	0.07
PRB_P15	B	0.18
PRB_P16	B	0.09

5.4.7 DAC Playback on Headphones, Stereo, 192 kHz, DVDD = 1.8 V, AVDD = 3.3 V, HVDD = 3.3 V

DOSR = 32, Processing Block = PRB_P17 (Interpolation Filter C)

Power consumption = 27.05 mW

Table 5-13. PRB_P17 Alternative Processing Blocks, 27.05 mW

Processing Block	Filter	Estimated Power Change (mW)
PRB_P18	C	5.28
PRB_P19	C	1.98

5.4.8 DAC Playback on Line Out (10 k-Ω load), Stereo, 48 kHz, DVDD = 1.8 V, AVDD = 3.0 V, HVDD = 3.0 V

DOSR = 64, Processing Block = PRB_P7 (Interpolation Filter B)

Power consumption = 12.85 mW

5.5 Audio ADC and Analog Inputs

5.5.1 MICBIAS and Microphone Preamplifier

The TSC2117 includes a microphone bias circuit which can source up to 4 mA of current, and is programmable to a 2-V, 2.5-V, or AVDD level. The level can be controlled by writing to page 1/register 46, bits D1–D0. This functionality is shown in [Table 5-14](#).

Table 5-14. MICBIAS Settings

D1	D0	FUNCTIONALITY
0	0	MICBIAS output is powered down.
0	1	MICBIAS output is powered to 2 V.
1	0	MICBIAS output is powered to 2.5 V.
1	1	MICBIAS output is powered to AVDD.

During normal operation, MICBIAS can be set to 2.5 V for better performance. However, depending on the model of microphone that is selected, optimal performance might be obtained at another setting, so the performance at a given setting should be verified.

The lowest current consumption occurs when MICBIAS is powered down. The next-lowest current consumption occurs when MICBIAS is set at AVDD.

Because of the oversampling nature of the audio ADC and the integrated digital decimation filtering, requirements for analog anti-aliasing filtering are very relaxed. The TSC2117 integrates a second-order analog anti-aliasing filter with 20-dB attenuation at 1 MHz. This filter, combined with the digital decimation filter, provides sufficient anti-aliasing filtering without requiring any external components.

The MIC PGA supports analog gain control from from 0 dB to 59.5 dB in steps of 0.5 dB. These gain levels can be controlled by writing to page 1/register 47, bits D6–D0. The PGA gain changes are implemented with internal soft-stepping. This soft-stepping ensures that volume-control changes occur smoothly with no audible artifacts. On reset, the MIC PGA gain defaults to a mute condition, with soft stepping enabled. The ADC soft-stepping control can be enabled or disabled by writing to page 0/register 81, bits D1–D0. ADC soft-stepping timing is provided by the internal oscillator and internal divider logic block.

The input feed-forward resistance for the MIC input of the microphone PGA stage has three settings of 10 k Ω , 20 k Ω , and 40 k Ω , which are controlled by writing to page 1/register 48, bits D7 and D6. The input feed-forward resistance value selected affects the gain of the microphone PGA. The ADC PGA gain for the MIC input depends on the setting of page 1/registers 48 and 49, bits D7–D6. If D7–D6 are set to 01, then the ADC PGA has 6 dB more gain with respect to the value programmed using page 1/register 47. If D7–D6 are set to 10, then the ADC PGA has the same gain as programmed using page 1/register 47. If D7–D6 are set to 11, then the ADC PGA has 6 dB less gain with respect to the value programmed using page 1/register 47. The same gain scaling is also valid for the AUX1 and AUX2 input, based on the feed-forward resistance selected using page 1/register 48, bits D5–D2.

Table 5-15. PGA Gain Versus Input Impedance

Page1 Reg 47 D6..D0	EFFECTIVE GAIN APPLIED BY PGA					
	Single-Ended			Differential		
	RIN = 10k	RIN = 20k	RIN = 40k	RIN = 10k	RIN = 20K	RIN = 40k
000 0000	6dB	0dB	-6dB	12dB	6dB	0dB
000 0001	6.5dB	0.5dB	-5.5dB	12.5dB	6.5dB	0.5dB
000 0010	7dB	1dB	-5dB	13dB	7dB	1dB
...

The MIC PGA gain can be controlled either by an AGC loop or as a fixed gain. See [Figure 1-1](#) for the various analog input routings to the MIC PGA that are supported in the single-ended and differential configurations. The AGC can be enabled by writing to page 0/register 86, bit D7. If the AGC is not enabled, then setting a fixed gain is done by writing to page 1/register 47, bits D6–D0. Because the TSC2117 supports soft-stepping gain changes, a read-only flag on page 0/register 36, bit D7 is set whenever the gain applied by PGA equals the desired value set by the gain register. The MIC PGA can be enabled by writing to page 1/register 47, bit D7. ADC muting can be done by writing to page 0/register 82, bit D7 and page 1/register 47, bit D7. Disabling the MIC PGA sets the gain to 0 dB. Muting the ADC causes the digital output to mute so that the output value remains fixed. When soft-stepping is enabled, the CODEC_CLKIN signal must stay active until after the ADC power-down register is written, in order to ensure that soft-stepping to mute has had time to complete. When the ADC POWER UP flag is no longer set, the CODEC_CLKIN signal can be shut down.

5.5.2 Automatic Gain Control (AGC)

The TSC2117 includes automatic gain control (AGC) for the microphone input (MIC). AGC can be used to maintain nominally constant output-signal amplitude when recording speech signals. This circuitry automatically adjusts the MIC PGA gain as the input signal becomes overly loud or very weak, such as when a person speaking into a microphone moves closer to or farther from the microphone. The AGC algorithm has several programmable settings, including target gain, attack and decay time constants, noise threshold, and maximum PGA applicable, that allow the algorithm to be fine-tuned for any particular application. The algorithm uses the absolute average of the signal (which is the average of the absolute value of the signal) as a measure of the nominal amplitude of the output signal. Because the gain can be changed at the sample interval time, the AGC algorithm operates at the ADC_{f_s} clock rate.

Target level represents the nominal output level at which the AGC attempts to hold the ADC output signal level. The TSC2117 allows programming of eight different target levels, which can be programmed from -5.5 dB to -24 dB relative to a full-scale signal. Because the TSC2117 reacts to the signal absolute average and not to peak levels, it is recommended that the target level be set with enough margin to avoid clipping at the occurrence of loud sounds.

An AGC low-pass filter is used to help determine the average level of the input signal. This average level is compared to the programmed detection levels in the AGC to provide the correct functionality. This low-pass filter is in the form of a first-order IIR filter. Programming this filter is done by writing to page 4/registers 2–7. Two 8-bit registers are used to form the 16-bit digital coefficient as shown on the register map. In this way, a total of six registers are programmed to form the three IIR coefficients.

Attack time determines how quickly the AGC circuitry reduces the PGA gain when the input signal is too loud. Programming the attack time is done by writing to page 0/register 89, bits D7–D0.

Decay time determines how quickly the PGA gain is increased when the input signal is too low. Programming the decay time is done by writing to page 0/register 90, bits D7–D0.

Noise threshold is a reference level. If the input speech average value falls below the noise threshold, the AGC considers it as a silence and hence brings down the gain to 0 dB in steps of 0.5 dB every sample period and sets the noise-threshold flag. The gain stays at 0 dB unless the input speech signal average rises above the noise-threshold setting. This ensures that noise is not amplified in the absence of speech. The noise-threshold level in the AGC algorithm is programmable from –30 dB to –90 dB for the microphone input. When the AGC noise threshold is set to –70 dB, –80 dB, or –90 dB, the microphone input maximum PGA applicable setting must be greater than or equal to 11.5 dB, 21.5 dB, or 31.5 dB, respectively. This operation includes debounce and hysteresis to prevent the AGC gain from cycling between high gain and 0 dB when signals are near the noise threshold level. When the noise-threshold flag is set, the status of the gain applied by the AGC and the saturation flag should be ignored. Programming the noise debounce is done by writing to page 0/register 91, bits D4–D0. Programming the signal debounce is done by writing to page 0/register 92, bits D3–D0.

Max PGA applicable allows the user to restrict maximum gain applied by AGC. This can be used for limiting PGA gain in situations where environmental noise is greater than the programmed noise threshold. Microphone input maximum PGA can be programmed from 0 dB to 59.5 dB in steps of 0.5 dB. Programming the maximum PGA gain allowed by the AGC is done by writing to page 0/register 88, bits D6–D0.

See [Table 5-16](#) for various AGC programming options. AGC can be used only if the microphone input is routed to the ADC channel.

Table 5-16. AGC Settings⁽¹⁾

CONTROL REGISTER	BIT	FUNCTION
36	D5 (Read-only)	AGC saturation flag
39	D3 (Read-only)	ADC saturation flag
45	D6 (Read-only)	Signal to level setting of noise threshold
86	D7	AGC enable
86	D6–D4	Target level
87	D7–D6	Hysteresis
87	D5–D1	Noise threshold
88	D6–D0	Maximum PGA applicable
89	D7–D0	Time constants (attack time)
90	D7–D0	Time constants (decay time)
91	D4–D0	Debounce time (noise)
92	D3–D0	Debounce time (signal)
93	D7–D0 (Read-only)	Gain applied by AGC

(1) All registers shown in this table are located on page 0.

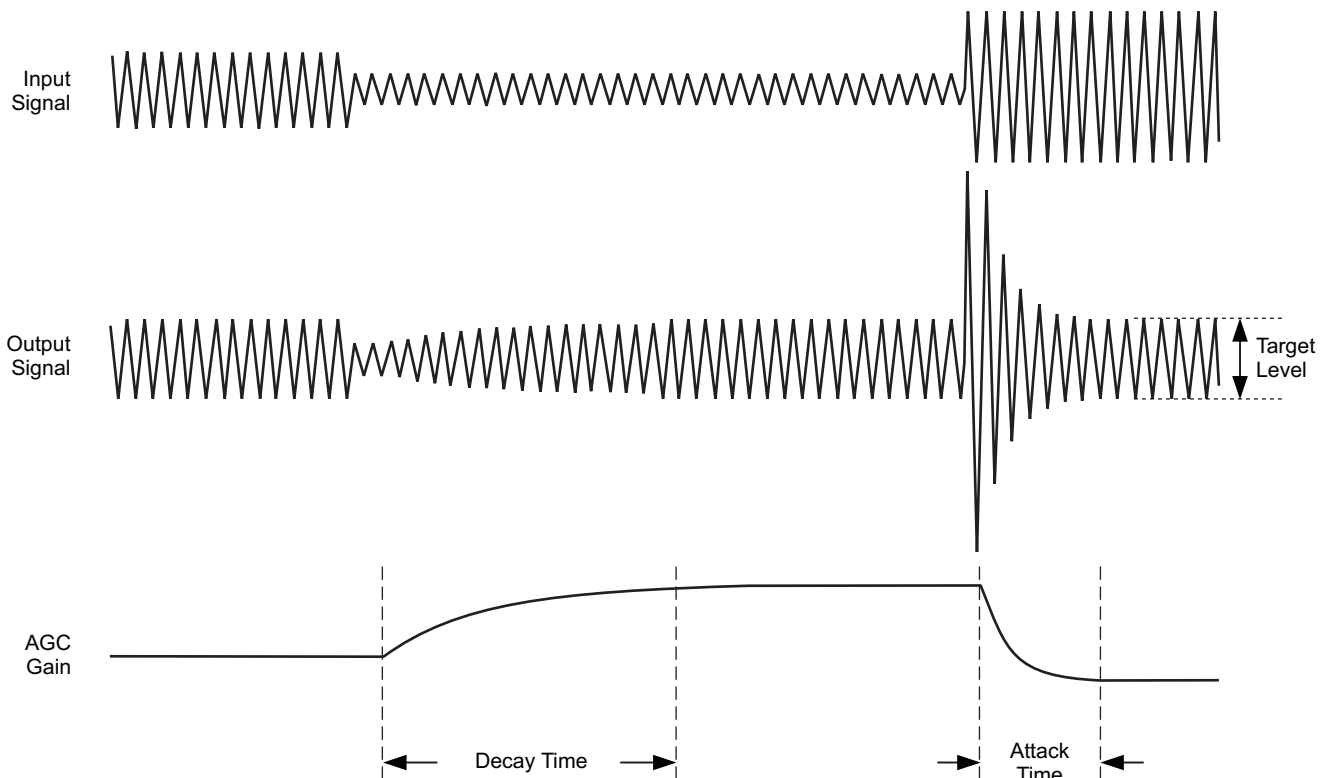

W0002-01

Figure 5-2. AGC Characteristics

The AGC settings should be set based on user and system conditions, such as microphone selection and sensitivity, acoustics (plastics) around the microphone which affect the microphone pattern, expected distance and direction between microphone and sound source, acoustic background noise, etc.

One example of AGC code follows, but actual use of code should be verified based on application usage. Note that the AGC code should be set up before powering up the ADC.

```
##### AGC ENABLE EXAMPLE CODE ##### ## Switch to Page-
0 w 30 00 00 # Set AGC enable and Target Level = -
10 dB # Target level can be set lower if clipping occurs during speech # Target level is
adjusted considering Max Gain also w 30 56 A0 # AGC hysteresis=DISABLE, noise threshold = -
90dB # Noise threshold should be set at higher level if noisy background is present in
application w 30 57 FE # AGC maximum gain= 40 dB # Higher Max gain is a trade off between
gaining up a low sensitivity MIC, and the background # acoustic noise # Microphone bias voltage
(MICBIAS) level can be used to change the Microphone Sensitivity w 30 58 50 # Attack
time=864/Fs w 30 59 68 # Decay time=22016/Fs w 30 5A A8 # Noise debounce 0 ms # Noise debounce
time can be increased if needed w 30 5B 00 # Signal debounce 0 ms # Signal debounce time can be
increased if needed w 30 5C 00 ##### END of AGC SET UP
#####
```

5.5.3 Delta-Sigma ADC

The analog-to-digital converter has a delta-sigma modulator with an oversampling ratio (AOSR) up to 128. The ADC can support a maximum output rate of 192 kHz.

ADC power up is controlled by writing to page 0/register 81, bit D7. An ADC power-up condition can be verified by reading page 0/register 36, bit D6.

5.5.4 ADC Decimation Filtering and Signal Processing

The TSC2117 ADC channel includes built-in digital decimation filters to process the oversampled data from the delta-sigma modulator to generate digital data at the Nyquist sampling rate with high dynamic range. The decimation filter can be chosen from three different types, depending on the required frequency response, group delay, and sampling rate.

5.5.4.1 ADC Processing Blocks

The TSC2117 offers a range of processing blocks which implement various signal processing capabilities along with decimation filtering. These processing blocks give users the choice of how much and what type of signal processing they may use and which decimation filter is applied.

The choices among these processing blocks allow the system designer to balance power conservation and signal-processing flexibility. Less signal-processing capability reduces the power consumed by the device. [Table 5-17](#) gives an overview of the available processing blocks of the ADC channel and their properties. The Resource Class (RC) column gives an approximate indication of power consumption.

The signal processing blocks available are:

- First-order IIR
- Scalable number of biquad filters
- Variable-tap FIR filter
- AGC

The processing blocks are tuned for common cases and can achieve high anti-alias filtering or low group delay in combination with various signal-processing effects such as audio effects and frequency shaping. The available first-order IIR, biquad, and FIR filters have fully user-programmable coefficients.

Table 5-17. ADC Processing Blocks

Processing Blocks	Channel	Decimation Filter	1st Order IIR Available	Number BiQuads	FIR	Required AOSR Value	Resource Class
PRB_R4	Mono	A	Yes	0	No	128, 64	3
PRB_R5	Mono	A	Yes	5	No	128, 64	4
PRB_R6	Mono	A	Yes	0	25-tap	128, 64	4
PRB_R10	Mono	B	Yes	0	No	64	2
PRB_R11	Mono	B	Yes	3	No	64	2
PRB_R12	Mono	B	Yes	0	20-tap	64	2
PRB_R16	Mono	C	Yes	0	No	32	2
PRB_R17	Mono	C	Yes	5	No	32	2
PRB_R18	Mono	C	Yes	0	25-tap	32	2

5.5.4.2 ADC Processing Blocks – Signal Chain Details

5.5.4.2.1 First-Order IIR, AGC, Filter A

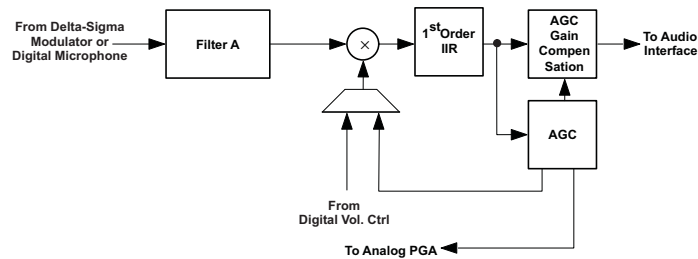

Figure 5-3. Signal Chain for PRB_R4

5.5.4.2.2 Five Biquads, First-Order IIR, AGC, Filter A

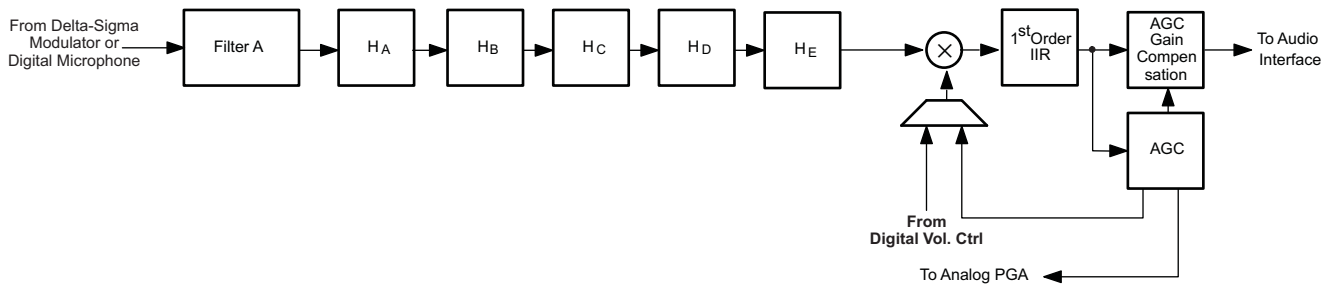

Figure 5-4. Signal Chain for PRB_R5

5.5.4.2.3 25-Tap FIR, First-Order IIR, AGC, Filter A

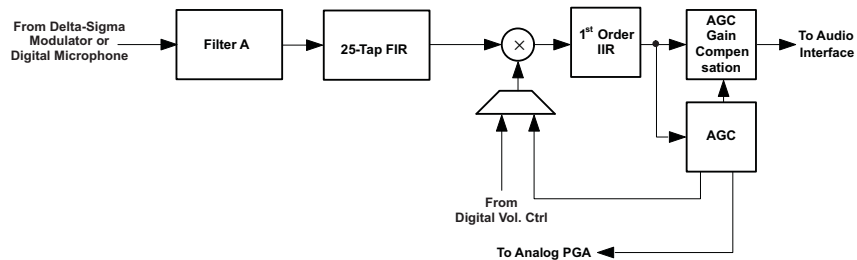

Figure 5-5. Signal Chain for PRB_R6

5.5.4.2.4 First-Order IIR, AGC, Filter B

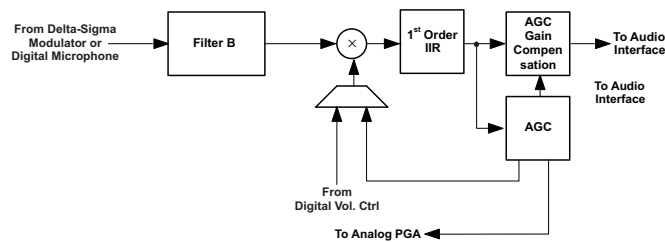

Figure 5-6. Signal Chain for PRB_R10

5.5.4.2.5 Three Biquads, First-Order IIR, AGC, Filter B

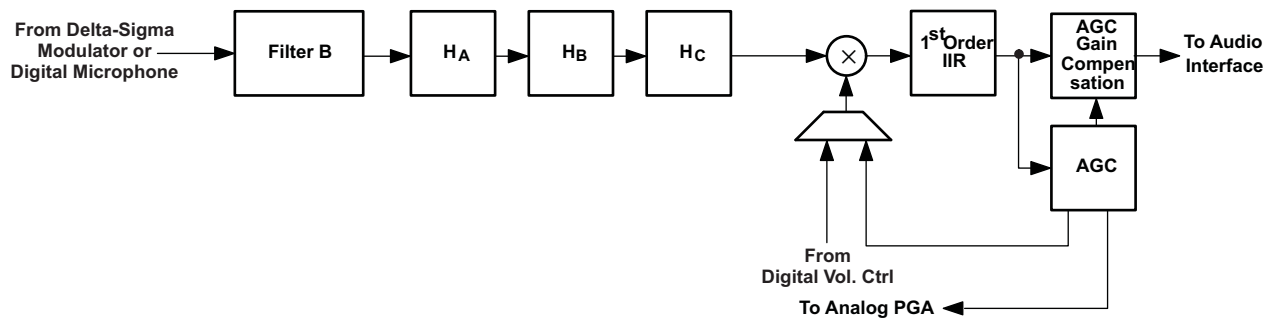

Figure 5-7. Signal Chain for PRB_R11

5.5.4.2.6 20-Tap FIR, First-Order IIR, AGC, Filter B

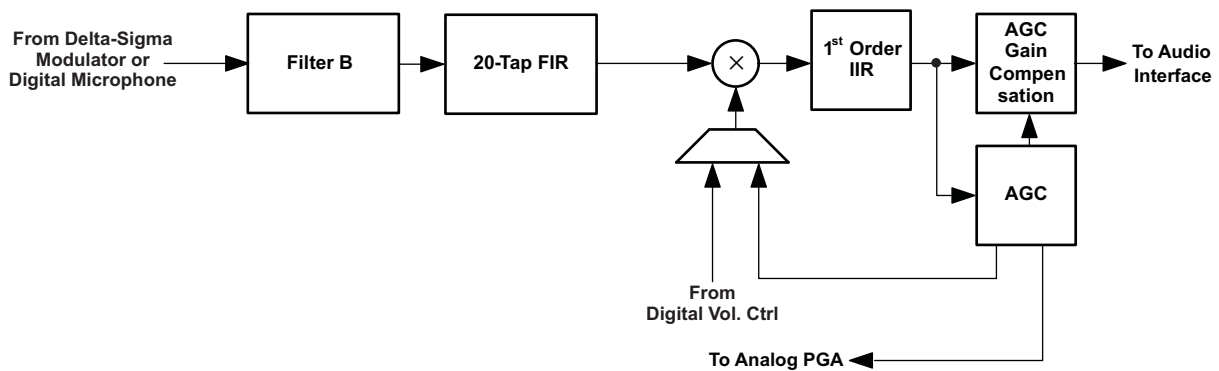

Figure 5-8. Signal Chain for PRB_R12

5.5.4.2.7 First-Order IIR, AGC, Filter C

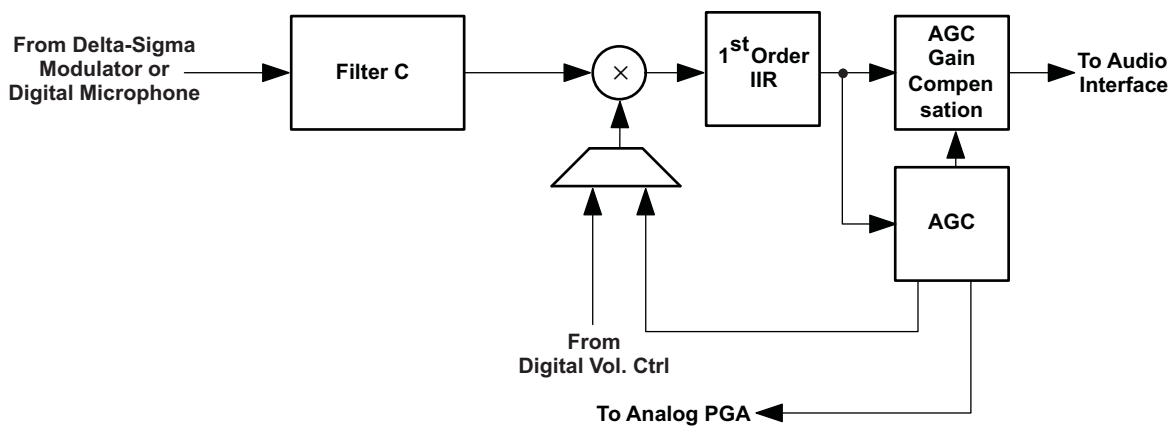

Figure 5-9. Signal Chain for PRB_R16

5.5.4.2.8 Five Biquads, First-Order IIR, AGC, Filter C

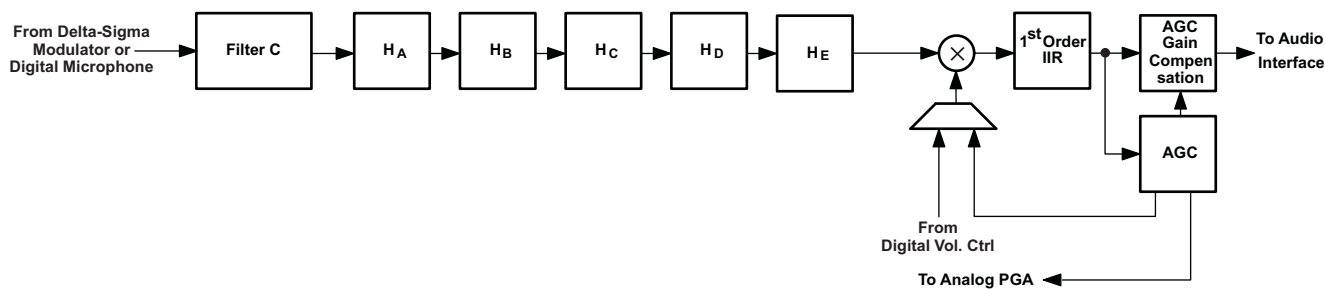

Figure 5-10. Signal Chain for PRB_R17

5.5.4.2.9 25-Tap FIR, First-Order IIR, AGC, Filter C

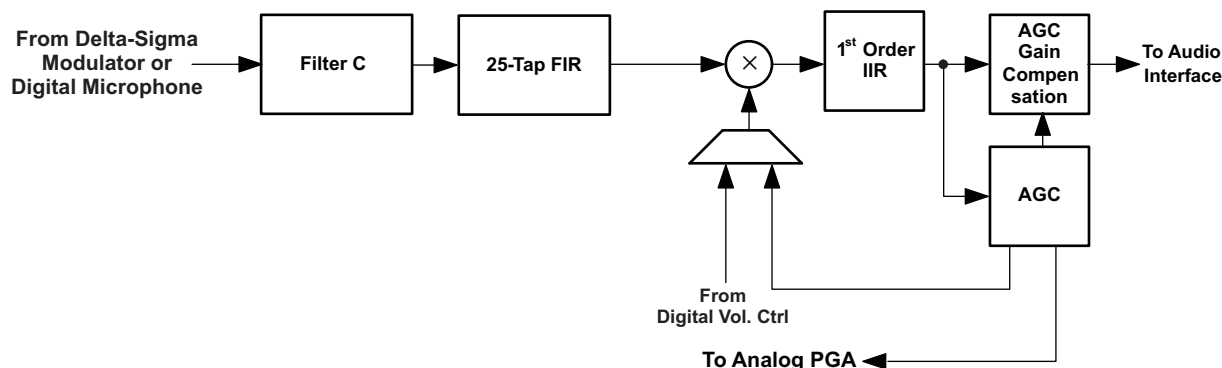

Figure 5-11. Signal Chain for PRB_R18

5.5.4.3 User-Programmable Filters

Depending on the selected processing block, different types and orders of digital filtering are available. A first-order IIR filter is always available, and is useful to filter out possible dc components of the signal efficiently. Up to five biquad sections or, alternatively, FIR filters of up to 25 taps are available for specific processing blocks. The coefficients of the available filters are arranged as sequentially indexed coefficients.

The coefficients of these filters are each 16 bits wide, in 2s-complement format, and occupy two consecutive 8-bit registers in the register space. Specifically, the filter coefficients are in 1.15 (one dot 15) format with a range from -1.0 (0x8000) to 0.999969482421875 (0x7FFF), as shown in Figure 5-12.

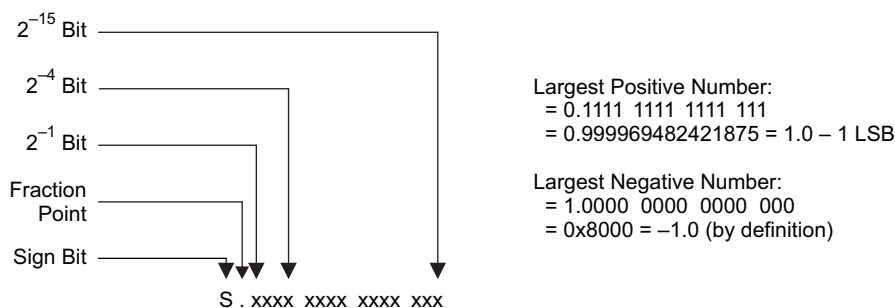

Figure 5-12. 1.15 2s-Complement Coefficient Format

5.5.4.3.1 First-Order IIR Section

The transfer function for the first-order IIR filter is given by

$$H(z) = \frac{N_0 + N_1 z^{-1}}{2^{15} - D_1 z^{-1}} \quad (1)$$

The frequency response for the first-order IIR section with default coefficients is flat at a gain of 0 dB.

Table 5-18. ADC First-Order IIR Filter Coefficients

Filter	Filter Coefficient	ADC Coefficient	Default (Reset) Values
First-order IIR	N0	Page 4/registers 8–9	0x7FFF (decimal 1.0 – LSB value)
	N1	Page 4/registers 10–11	0x0000
	D1	Page 4/registers 12–13	0x0000

5.5.4.3.2 Biquad Section

The transfer function of each of the biquad filters is given by

$$H(z) = \frac{N_0 + 2 \times N_1 z^{-1} + N_2 z^{-2}}{2^{15} - 2 \times D_1 z^{-1} - D_2 z^{-2}} \quad (2)$$

The default values for each biquad section yield an all-pass (flat) frequency response at a gain of 0 dB.

Table 5-19. ADC Biquad Filter Coefficients

Filter	Filter Coefficient	Filter Coefficient RAM Location	Default (Reset) Values
Biquad A	N0	Page 4/registers 14–15	0x7FFF (decimal 1.0 – LSB value)
	N1	Page 4/registers 16–17	0x0000
	N2	Page 4/registers 18–19	0x0000
	D1	Page 4/registers 20–21	0x0000
	D2	Page 4/registers 22–23	0x0000
Biquad B	N0	Page 4/registers 24–25	0x7FFF (decimal 1.0 – LSB value)
	N1	Page 4/registers 26–27	0x0000
	N2	Page 4/registers 28–29	0x0000
	D1	Page 4/registers 30–31	0x0000
	D2	Page 4/registers 32–33	0x0000
Biquad C	N0	Page 4/registers 34–35	0x7FFF (decimal 1.0 – LSB value)
	N1	Page 4/registers 36–37	0x0000
	N2	Page 4/registers 38–39	0x0000
	D1	Page 4/registers 40–41	0x0000
	D2	Page 4/registers 42–43	0x0000
Biquad D	N0	Page 4/registers 44–45	0x7FFF (decimal 1.0 – LSB value)
	N1	Page 4/registers 46–47	0x0000
	N2	Page 4/registers 48–49	0x0000
	D1	Page 4/registers 50–51	0x0000
	D2	Page 4/registers 52–53	0x0000
Biquad E	N0	Page 4/registers 54–55	0x7FFF (decimal 1.0 – LSB value)
	N1	Page 4/registers 56–57	0x0000
	N2	Page 4/registers 58–59	0x0000

Table 5-19. ADC Biquad Filter Coefficients (continued)

Filter	Filter Coefficient	Filter Coefficient RAM Location	Default (Reset) Values
	D1	Page 4/registers 60–61	0x0000
	D2	Page 4/registers 62–63	0x0000

5.5.4.3.3 FIR Section

Three of the available ADC processing blocks offer FIR filters for signal processing. Processing block PRB_R12 features a 20-tap FIR filter, whereas the processing blocks PRB_R6 and PRB_R18 feature a 25-tap FIR filter.

$$H(z) = \sum_{n=0}^M \text{FIR}_n z^{-n}$$

M = 24 for PRB_R6, PRB_R18

M = 19 for PRB_R12

(3)

The coefficients of the FIR filters are 16-bit 2s-complement format (2 bytes each) and correspond to the ADC coefficient space as listed in Table 5-20. Note that the default (reset) coefficients are not valid for the FIR filter. When the FIR filter is used, all applicable coefficients must be reprogrammed by the user. To reprogram the FIR filter coefficients as an all-pass filter, write value 0x00 to page 4/registers 24, 25, 34, 35, 44, 45, 54, and 55.

Table 5-20. ADC FIR Filter Coefficients

Filter Coefficient	Filter Coefficient RAM Location	Default (Reset) Values – Not Valid for the FIR Filter – Must Be Reprogrammed by User
Fir0	Page 4/registers 14–15	0x7FFF (decimal 1.0 – LSB value)
Fir1	Page 4/registers 16–17	0x0000
Fir2	Page 4/registers 18–19	0x0000
Fir3	Page 4/registers 20–21	0x0000
Fir4	Page 4/registers 22–23	0x0000
Fir5	Page 4/registers 24–25	0x7FFF (decimal 1.0 – LSB value)
Fir6	Page 4/registers 26–27	0x0000
Fir7	Page 4/registers 28–29	0x0000
Fir8	Page 4/registers 30–31	0x0000
Fir9	Page 4/registers 32–33	0x0000
Fir10	Page 4/registers 34–35	0x7FFF (decimal 1.0 – LSB value)
Fir11	Page 4/registers 36–37	0x0000
Fir12	Page 4/registers 38–39	0x0000
Fir13	Page 4/registers 40–41	0x0000
Fir14	Page 4/registers 42–43	0x0000
Fir15	Page 4/registers 44–45	0x7FFF (decimal 1.0 – LSB value)
Fir16	Page 4/registers 46–47	0x0000
Fir17	Page 4/registers 48–49	0x0000
Fir18	Page 4/registers 50–51	0x0000
Fir19	Page 4/registers 52–53	0x0000
Fir20	Page 4/registers 54–55	0x7FFF (decimal 1.0 – LSB value)
Fir21	Page 4/registers 56–57	0x0000
Fir22	Page 4/registers 58–59	0x0000
Fir23	Page 4/registers 60–61	0x0000
Fir24	Page 4/registers 62–63	0x0000

5.5.4.4 ADC Digital Decimation Filter Characteristics

The TSC2117 offers three different types of decimation filters. The integrated digital decimation filter removes high-frequency content and downsamples the audio data from an initial sampling rate of $\text{AOSR} \times f_s$ to the final output sampling rate of f_s . The decimation filtering is achieved using a higher-order CIC filter followed by linear-phase FIR filters. The decimation filter cannot be chosen by itself; it is implicitly set through the chosen processing block.

The following subsections describe the properties of the available filters A, B, and C.

5.5.4.4.1 Decimation Filter A

This filter is intended for use at sampling rates up to 48 kHz. When configuring this filter, the oversampling ratio of the ADC can either be 128 or 64. For highest performance, the oversampling ratio must be set to 128.

Filter A can also be used for 96 kHz at an AOSR of 64.

Table 5-21. ADC Decimation Filter A, Specification

Parameter	Condition	Value (Typical)	Unit
AOSR = 128			
Filter gain pass band	$0 \dots 0.39 f_s$	0.062	dB
Filter gain stop band	$0.55 \dots 64 f_s$	-73	dB
Filter group delay		$17/f_s$	s
Pass-band ripple, 8 ksps	$0 \dots 0.39 f_s$	0.062	dB
Pass-band ripple, 44.1 ksps	$0 \dots 0.39 f_s$	0.05	dB
Pass-band ripple, 48 ksps	$0 \dots 0.39 f_s$	0.05	dB
AOSR = 64			
Filter gain pass band	$0 \dots 0.39 f_s$	0.062	dB
Filter gain stop band	$0.55 \dots 32 f_s$	-73	dB
Filter group delay		$17/f_s$	s
Pass-band ripple, 8 ksps	$0 \dots 0.39 f_s$	0.062	dB
Pass-band ripple, 44.1 ksps	$0 \dots 0.39 f_s$	0.05	dB
Pass-band ripple, 48 ksps	$0 \dots 0.39 f_s$	0.05	dB
Pass-band ripple, 96 ksps	$0 \dots 20 \text{ kHz}$	0.1	dB

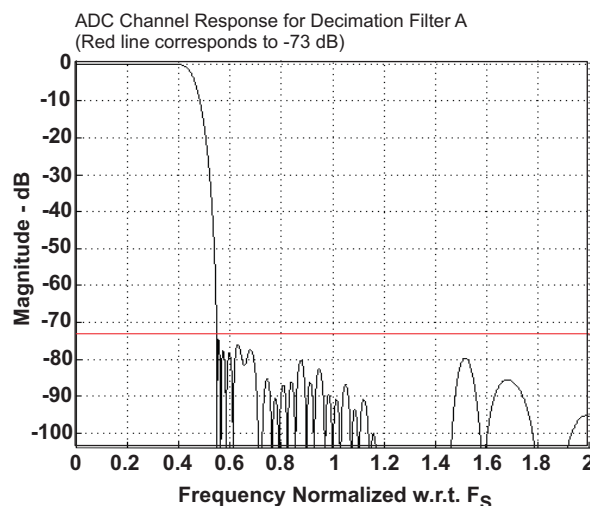

Figure 5-13. ADC Decimation Filter A, Frequency Response

5.5.4.4.2 Decimation Filter B

Filter B is intended to support sampling rates up to 96 kHz at an oversampling ratio of 64.

Table 5-22. ADC Decimation Filter B, Specifications

Parameter	Condition	Value (Typical)	Unit
AOSR = 64			
Filter gain pass band	0...0.39 f_S	± 0.077	dB
Filter gain stop band	0.60 f_S ...32 f_S	-46	dB
Filter group delay		11/ f_S	s
Pass-band ripple, 8 ksps	0...0.39 f_S	0.076	dB
Pass-band ripple, 44.1 ksps	0...0.39 f_S	0.06	dB
Pass-band ripple, 48 ksps	0...0.39 f_S	0.06	dB
Pass-band ripple, 96 ksps	0...20 kHz	0.11	dB

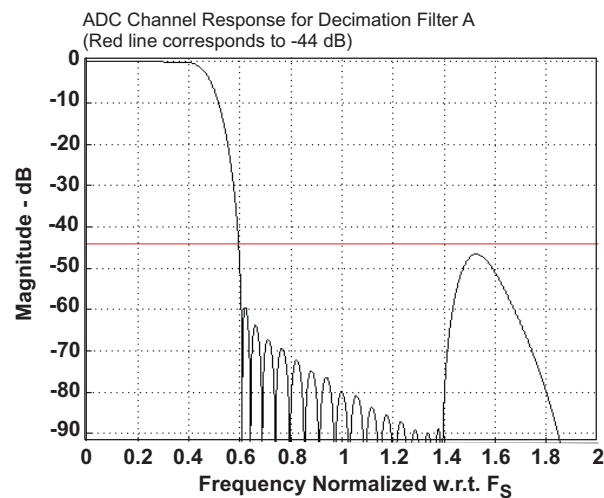

Figure 5-14. ADC Decimation Filter B, Frequency Response

5.5.4.4.3 Decimation Filter C

Filter C along with an AOSR of 32 is specially designed for 192-kSPS operation for the ADC. The pass band, which extends up to $0.11 \times f_S$ (corresponding to 21 kHz), is suited for audio applications.

Table 5-23. ADC Decimation Filter C, Specifications

Parameter	Condition	Value (Typical)	Unit
Filter gain from 0 to $0.11 f_S$	$0 \dots 0.11 f_S$	± 0.033	dB
Filter gain from $0.28 f_S$ to $16 f_S$	$0.28 f_S \dots 16 f_S$	-60	dB
Filter group delay		$11/f_S$	s
Pass-band ripple, 8 kSPS	$0 \dots 0.11 f_S$	0.033	dB
Pass-band ripple, 44.1 kSPS	$0 \dots 0.11 f_S$	0.033	dB
Pass-band ripple, 48 kSPS	$0 \dots 0.11 f_S$	0.032	dB
Pass-band ripple, 96 kSPS	$0 \dots 0.11 f_S$	0.032	dB
Pass-band ripple, 192 kSPS	$0 \dots 20 \text{ kHz}$	0.086	dB

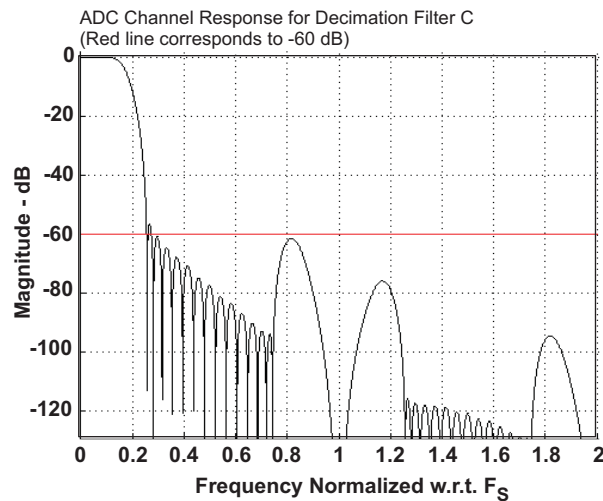

Figure 5-15. ADC Decimation Filter C, Frequency Response

5.5.4.5 ADC Data Interface

The decimation filter and signal processing block in the ADC channel passes 32-bit data words to the audio serial interface once every cycle of ADC_{f_S} . During each cycle of ADC_{f_S} , a pair of data words (for left and right channel) is passed. The audio serial interface rounds the data to the required word length of the interface before converting to serial data. Because the TSC2117 has only a mono ADC, it passes the same data to both the left and right channels of the audio serial interface.

5.5.5 Updating ADC Digital Filter Coefficients During Record

When it is required to update the ADC digital filter coefficients during record, care must be taken to avoid click and pop noise or even a possible oscillation noise. These artifacts can occur if the ADC coefficients are updated without following the proper update sequence. The correct sequence is shown in [Figure 5-16](#). The values for the times listed are conservative and should be used for software purposes.

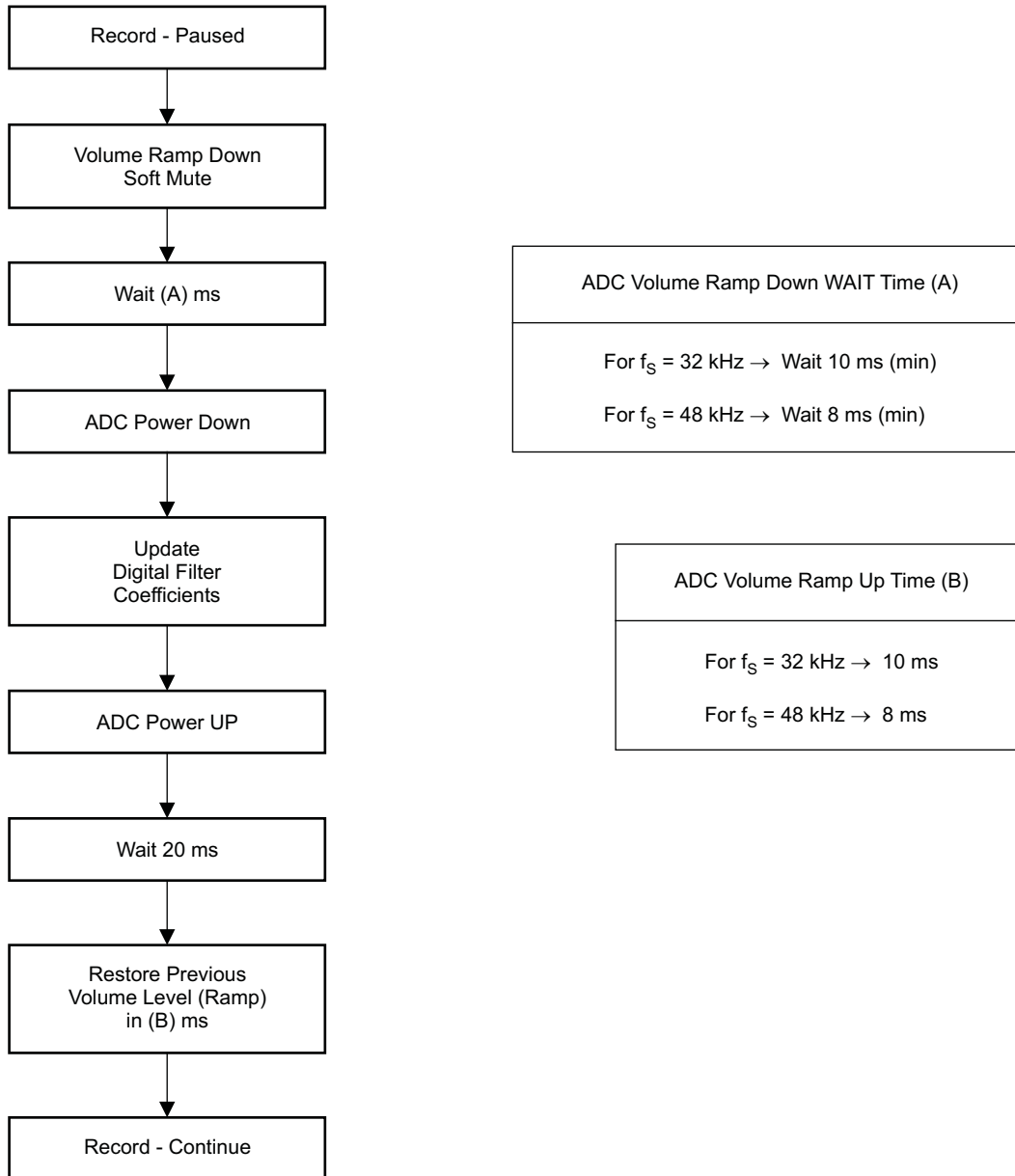

F0023-02

Figure 5-16. Updating ADC Digital Filter Coefficients During Record

5.5.6 Digital Microphone Function

In addition to supporting analog microphones, the TSC2117 can also interface to one digital microphone using the mono ADC channel. Figure 5-17 shows the digital microphone interface block diagram and Figure 5-18 shows the timing diagram for the digital microphone interface.

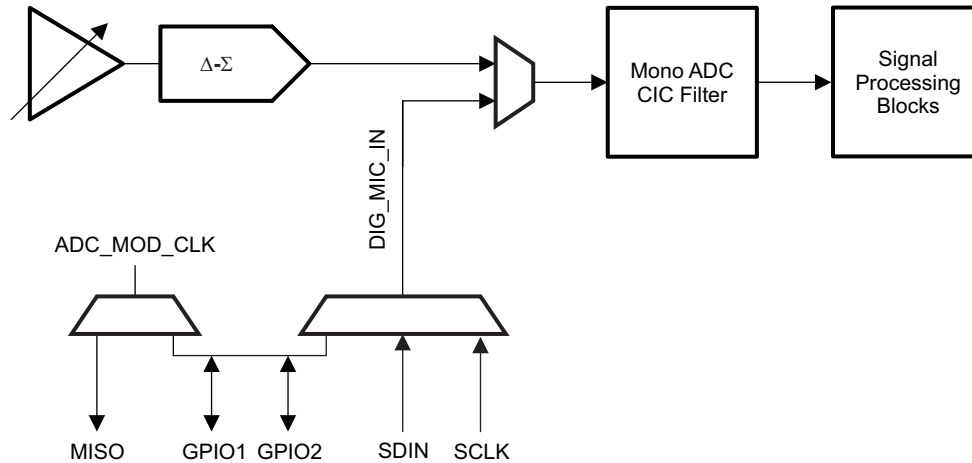

Figure 5-17. Digital Microphone in the TSC2117

The TSC2117 outputs internal clock ADC_MOD_CLK on the GPIO1 pin (page 0/register 51, bits D5–D2 = 1010), GPIO2 pin (page 0/register 52, bits D5–D2 = 1010), or MISO pin (page 0/register 55, bits D4–D1 = 0111). This clock can be connected to the external digital microphone device. The single-bit output of the external digital microphone device can be connected to the GPIO1, GPIO2, SDIN, or SCLK pins (for this mode, page 0/register 51, 52, 54, or 56 must be configured as a secondary input). Internally, the TSC2117 latches the steady value of the mono ADC data on the rising edge of ADC_MOD_CLK.

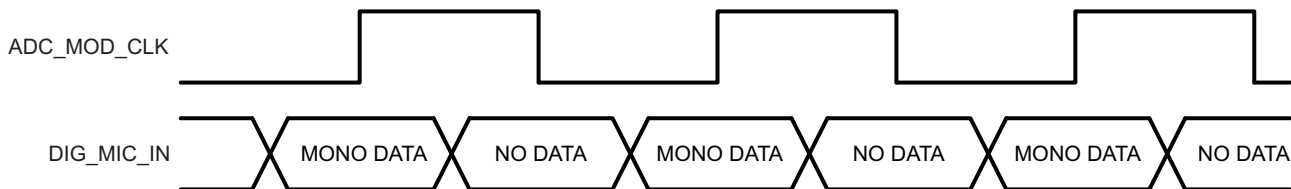

Figure 5-18. Timing Diagram for Digital Microphone Interface

When the digital microphone mode is enabled, the analog section of the ADC can be powered down and bypassed for power efficiency. The AOSR value for the ADC channel must be configured to select the desired decimation ratio to be achieved, based on the external digital microphone properties.

5.5.7 DC Measurement

The TSC2117 supports a highly flexible dc measurement feature using the high-resolution oversampling and noise-shaping ADC. This mode can be used when the ADC channel is not used for the voice/audio record function. This mode can be enabled by programming page 0/register 102, bit D7. The converted data is 24 bits, using the 2.22 numbering format. The value of the converted data for ADC channel can be read back from page 0/registers 104–106. Before reading back the converted data, page 0/register 103, bit D6 must be programmed to 1 in order to latch the converted data into the read-back registers. After the converted data is read back, page 0/register 103, bit D6 must be immediately reset to 0. In dc-measurement mode, two measurement modes are supported.

Mode A

In dc-measurement mode A, a variable-length averaging filter is used. The length of averaging filter D can be programmed from 1 to 20 by programming page 0/register 102, bits D4–D0. To choose mode A, page 0/register 102, bit D5 must be programmed to 0.

Mode B

To choose mode B, page 0/register 102, bit D5 must be programmed to 1. In dc-measurement mode B, a first-order IIR filter is used. The coefficients of this filter are determined by D, page 0/register 102, bits D4–D0. The nature of the filter is given in [Table 5-24](#).

Table 5-24. DC Measurement Bandwidth Settings

D:Page 0/Register 102, Bits D4–D0	–3 dB BW (kHz)	–0.5 dB BW (kHz)
1	688.44	236.5
2	275.97	96.334
3	127.4	44.579
4	61.505	21.532
5	30.248	10.59
6	15.004	5.253
7	7.472	2.616
8	3.729	1.305
9	1.862	652
10	931	326
11	465	163
12	232.6	81.5
13	116.3	40.7
14	58.1	20.3
15	29.1	10.2
16	14.54	5.09
17	7.25	2.54
18	3.63	1.27
19	1.8	0.635
20	0.908	0.3165

By programming page 0/register 103, bit D5 to 1, the averaging filter is periodically reset after 2^R number of ADC_MOD_CLK periods, where R is programmed in page 0/register 103, bits D4–D0. When page 0/register 103, bit D5 is set to 1, then the value of D should be less than the value of R. When page 0/register 103, bit D5 is programmed to 0, the averaging filter is never reset.

5.6 Audio DAC and Audio Analog Outputs

Each channel of the stereo audio DAC consists of a digital audio processing block, a digital interpolation filter, a digital delta-sigma modulator, and an analog reconstruction filter. This high oversampling ratio (normally DOSR is between 32 and 128) exhibits good dynamic range by ensuring that the quantization noise generated within the delta-sigma modulator stays outside of the audio frequency band. Audio analog outputs include stereo headphone/lineouts and stereo class-D speaker outputs.

5.6.1 DAC

The TSC2117 stereo audio DAC supports data rates from 8 kHz to 192 kHz. Each channel of the stereo audio DAC consists of a signal-processing engine with fixed processing blocks, a programmable miniDSP, a digital interpolation filter, multibit digital delta-sigma modulator, and an analog reconstruction filter. The DAC is designed to provide enhanced performance at low sampling rates through increased oversampling and image filtering, thereby keeping quantization noise generated within the delta-sigma modulator and signal images strongly suppressed within the audio band to beyond 20 kHz. To handle multiple input rates and optimize power dissipation and performance, the TSC2117 allows the system designer to program the oversampling rates over a wide range from 1 to 1024 by configuring page 0/registers 13 and 14. The system designer can choose higher oversampling ratios for lower input data rates and lower oversampling ratios for higher input data rates.

The TSC2117 DAC channel includes a built-in digital interpolation filter to generate oversampled data for the delta-sigma modulator. The interpolation filter can be chosen from three different types, depending on required frequency response, group delay, and sampling rate.

DAC power up is controlled by writing to page 0/register 63, bit D7 for the left channel and bit D6 for the right channel. The left-channel DAC clipping flag is provided as a read-only bit on page 0/register 39, bit D7. The right-channel DAC clipping flag is provided as a read-only bit on page 0/register 39, bit D6.

5.6.1.1 DAC Processing Blocks

The TSC2117 implements signal-processing capabilities and interpolation filtering via processing blocks. These fixed processing blocks give users the choice of how much and what type of signal processing they may use and which interpolation filter is applied.

The choices among these processing blocks allows the system designer to balance power conservation and signal-processing flexibility. [Table 5-25](#) gives an overview of all available processing blocks of the DAC channel and their properties. The resource-class column gives an approximate indication of power consumption for the digital (DVDD) supply; however, based on the out-of-band noise spectrum, the analog power consumption of the drivers (HVDD) may differ.

The signal processing blocks available are:

- First-order IIR
- Scalable number of biquad filters
- 3D effect
- Beep generator

The processing blocks are tuned for common cases and can achieve high image rejection or low group delay in combination with various signal processing effects such as audio effects and frequency shaping. The available first-order IIR and biquad filters have fully user-programmable coefficients.

Table 5-25. Overview – DAC Predefined Processing Blocks

Processing Block No.	Interpolation Filter	Channel	First-Order IIR Available	Number of Biquads	DRC	3D	Beep Generator	Resource Class
PRB_P1	A	Stereo	No	3	No	No	No	8
PRB_P2	A	Stereo	Yes	6	Yes	No	No	12
PRB_P3	A	Stereo	Yes	6	No	No	No	10
PRB_P4	A	Left	No	3	No	No	No	4
PRB_P5	A	Left	Yes	6	Yes	No	No	6
PRB_P6	A	Left	Yes	6	No	No	No	6
PRB_P7	B	Stereo	Yes	0	No	No	No	6
PRB_P8	B	Stereo	No	4	Yes	No	No	8
PRB_P9	B	Stereo	No	4	No	No	No	8
PRB_P10	B	Stereo	Yes	6	Yes	No	No	10
PRB_P11	B	Stereo	Yes	6	No	No	No	8
PRB_P12	B	Left	Yes	0	No	No	No	3
PRB_P13	B	Left	No	4	Yes	No	No	4
PRB_P14	B	Left	No	4	No	No	No	4
PRB_P15	B	Left	Yes	6	Yes	No	No	6
PRB_P16	B	Left	Yes	6	No	No	No	4
PRB_P17	C	Stereo	Yes	0	No	No	No	3
PRB_P18	C	Stereo	Yes	4	Yes	No	No	6
PRB_P19	C	Stereo	Yes	4	No	No	No	4
PRB_P20	C	Left	Yes	0	No	No	No	2
PRB_P21	C	Left	Yes	4	Yes	No	No	3
PRB_P22	C	Left	Yes	4	No	No	No	2
PRB_P23	A	Stereo	No	2	No	Yes	No	8
PRB_P24	A	Stereo	Yes	5	Yes	Yes	No	12
PRB_P25	A	Stereo	Yes	5	Yes	Yes	Yes	12

5.6.1.2 DAC Processing Blocks – Signal Chain Details

5.6.1.2.1 Three Biquads, Filter A

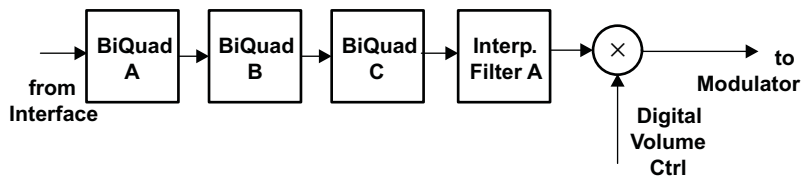
Figure 5-19. Signal Chain for PRB_P1 and PRB_P4

5.6.1.2.2 Six Biquads, First-Order IIR, DRC, Filter A or B

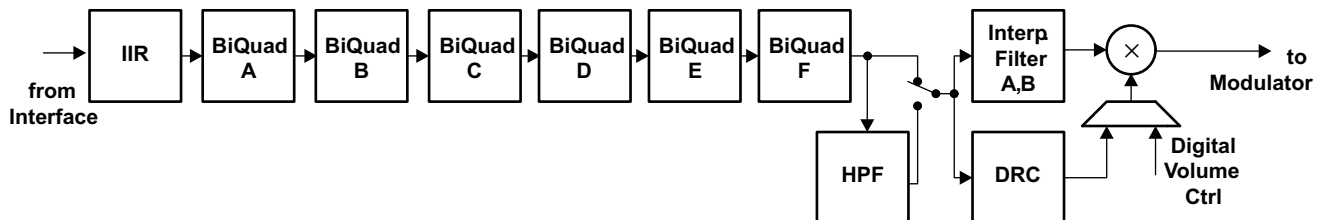
Figure 5-20. Signal Chain for PRB_P2, PRB_P5, PRB_P10, and PRB_P15

5.6.1.2.3 Six Biquads, First-Order IIR, Filter A or B

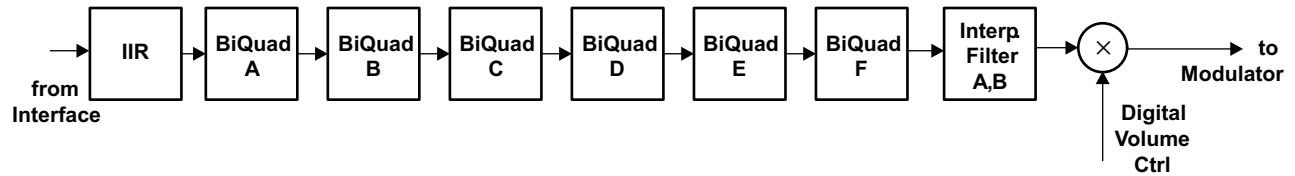

Figure 5-21. Signal Chain for PRB_P3, PRB_P6, PRB_P11, and PRB_P16

5.6.1.2.4 IIR, Filter B or C

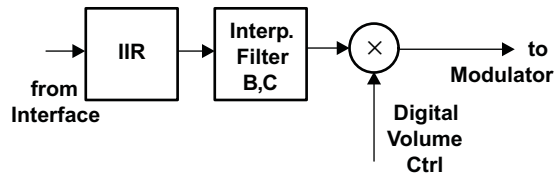

Figure 5-22. Signal Chain for PRB_P7, PRB_P12, PRB_P17, and PRB_P20

5.6.1.2.5 Four Biquads, DRC, Filter B

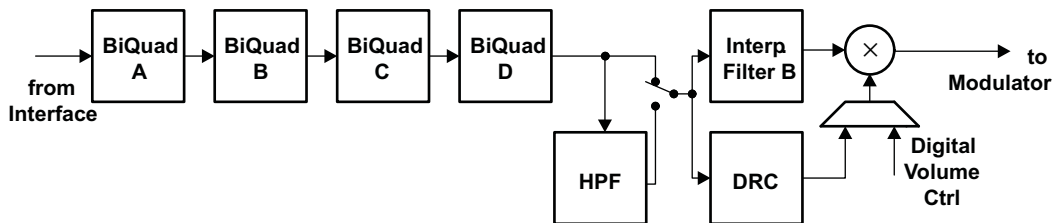

Figure 5-23. Signal Chain for PRB_P8 and PRB_P13

5.6.1.2.6 Four Biquads, Filter B

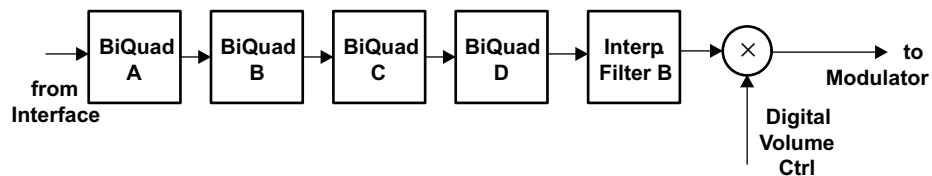

Figure 5-24. Signal Chain for PRB_P9 and PRB_P14

5.6.1.2.7 Four Biquads, First-Order IIR, DRC, Filter C

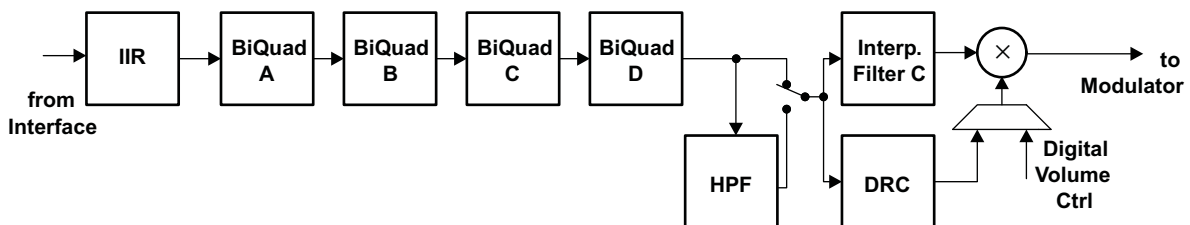

Figure 5-25. Signal Chain for PRB_P18 and PRB_P21

5.6.1.2.8 Four Biquads, First-Order IIR, Filter C

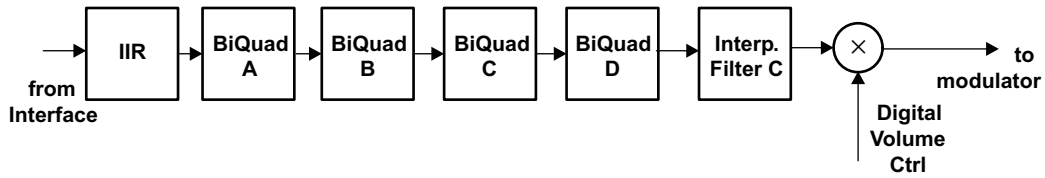
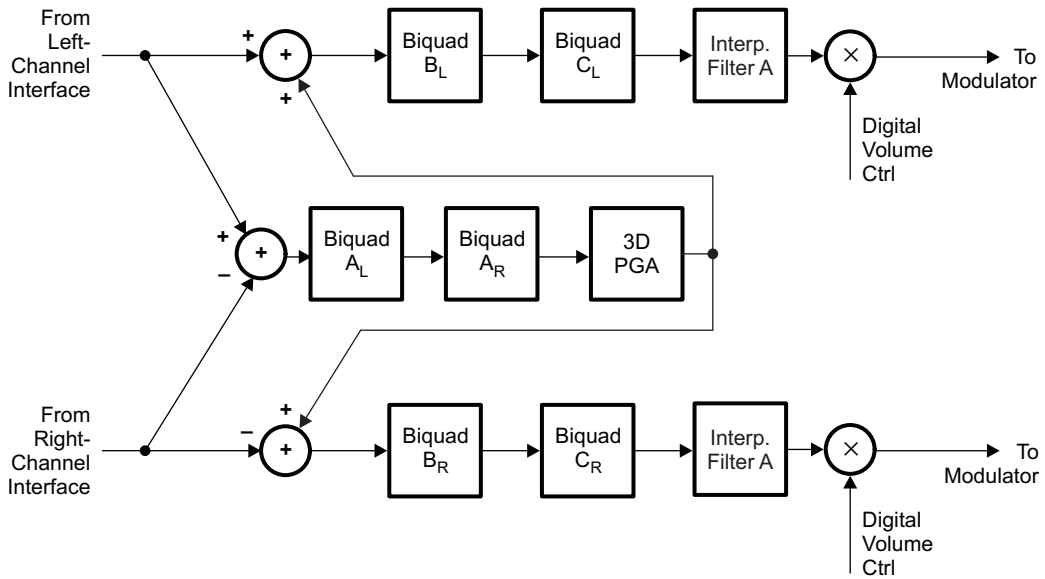

Figure 5-26. Signal Chain for PRB_P19 and PRB_P22

5.6.1.2.9 Two Biquads, 3D, Filter A



NOTE: A_L means biquad A of the left channel, and similarly, B_R means biquad B of the right channel.

Figure 5-27. Signal Chain for PRB_P23

5.6.1.2.10 Five Biquads, DRC, 3D, Filter A

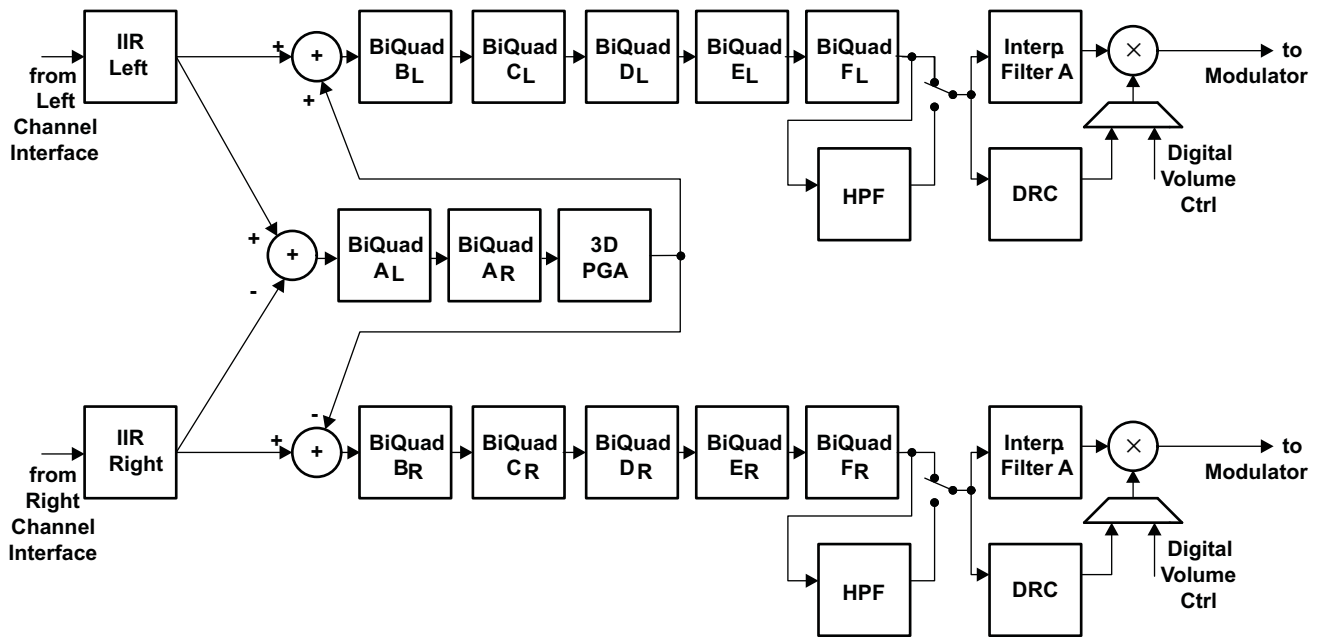

Figure 5-28. Signal Chain for PRB_P24

5.6.1.2.11 Five Biquads, DRC, 3D, Beep Generator, Filter A

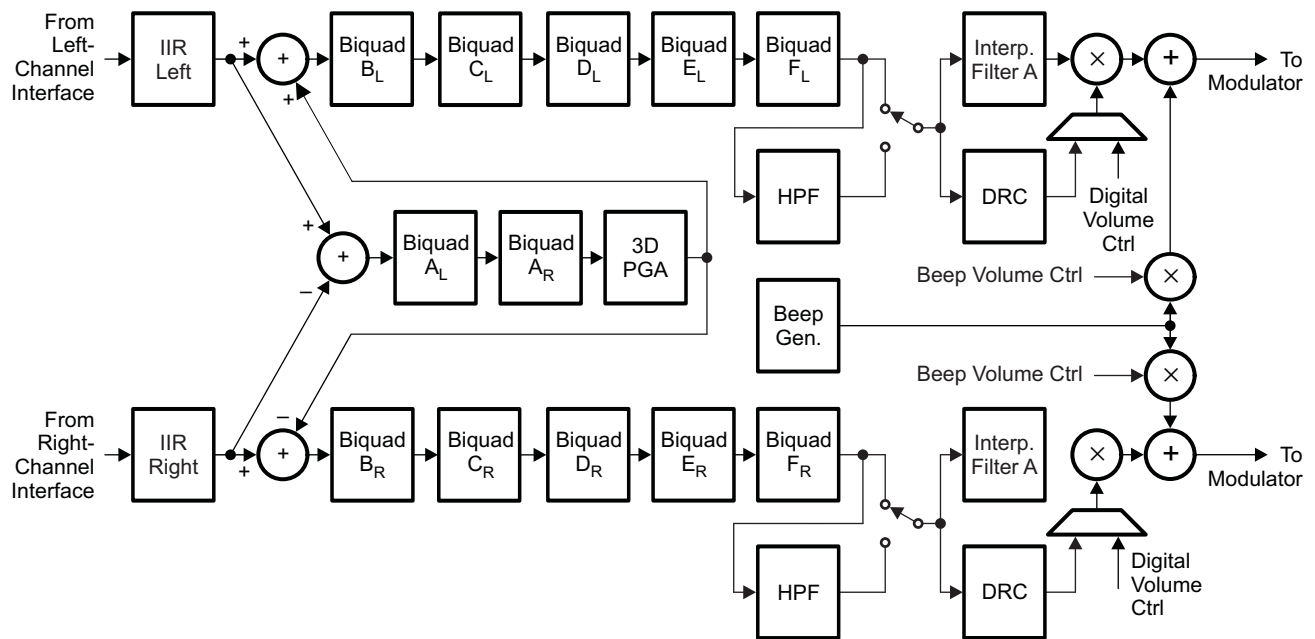

Figure 5-29. Signal Chain for PRB_P25

5.6.1.3 DAC User-Programmable Filters

Depending on the selected processing block, different types and orders of digital filtering are available. Up to six biquad sections are available for specific processing blocks.

The coefficients of the available filters are arranged as sequentially-indexed coefficients in two banks. If adaptive filtering is chosen, the coefficient banks can be switched on-the-fly.

When the DAC is running, the user-programmable filter coefficients are locked and cannot be accessed for either read or write.

However the TSC2117 offers an adaptive filter mode as well. Setting page 8/register 1, bit D2 = 1 turns on double buffering of the coefficients. In this mode, filter coefficients can be updated through the host and activated without stopping and restarting the DAC. This enables advanced adaptive filtering applications.

In the double-buffering scheme, all coefficients are stored in two buffers (buffers A and B). When the DAC is running and adaptive filtering mode is turned on, setting page 8/register 1, bit D0 = 1 switches the coefficient buffers at the next start of a sampling period. This bit is set back to 0 after the switch occurs. At the same time, page 8/register 1, bit D1 toggles.

The flag in page 8/register 1, bit D1 indicates which of the two buffers is actually in use.

Page 8/register 1, bit D1 = 0: buffer A is in use by the DAC engine; bit D1 = 1: buffer B is in use.

While the device is running, coefficient updates are always made to the buffer not in use by the DAC, regardless of the buffer to which the coefficients have been written.

Table 5-26. Adaptive-Mode Filter-Coefficient Buffer Switching

DAC Running?	Page 8, Reg 1, D(1)	Coefficient Buffer in Use	Writing to	Updates
No	0	None	C1, buffer A	C1, buffer A
No	0	None	C1, buffer B	C1, buffer B
Yes	0	Buffer A	C1, buffer A	C1, buffer B
Yes	0	Buffer A	C1, buffer B	C1, buffer B
Yes	1	Buffer B	C1, buffer A	C1, buffer A
Yes	1	Buffer B	C1, buffer B	C1, buffer A

The user-programmable coefficients C1 to C70 are defined on pages 8, 9, 10, and 11 for buffer A and pages 12, 13, 14, and 15 for buffer B.

The coefficients of these filters are each 16-bit, 2s-complement format, occupying two consecutive 8-bit registers in the register space. Specifically, the filter coefficients are in 1.15 (one dot 15) format with a range from –1.0 (0x8000) to 0.999969482421875 (0x7FFF) as shown in [Figure 5-12](#).

5.6.1.3.1 First-Order IIR Section

The IIR is of first order and its transfer function is given by

$$H(z) = \frac{N_0 + N_1 z^{-1}}{2^{15} - D_1 z^{-1}} \quad (4)$$

The frequency response for the first-order IIR section with default coefficients is flat.

Table 5-27. DAC IIR Filter Coefficients

Filter	Filter Coefficient	DAC Coefficient, Left Channel	DAC Coefficient, Right Channel	Default (Reset) Values
First-order IIR	N0	Page 9/registers 2–3	Page 9/registers 8–9	0x7FFF (decimal 1.0 – LSB value)
	N1	Page 9/registers 4–5	Page 9/registers 10–11	0x0000
	D1	Page 9/registers 6–7	Page 9/registers 12–13	0x0000

5.6.1.3.2 Biquad Section

The transfer function of each of the biquad filters is given by

$$H(z) = \frac{N_0 + 2 \times N_1 z^{-1} + N_2 z^{-2}}{2^{15} - 2 \times D_1 z^{-1} - D_2 z^{-2}} \quad (5)$$

Table 5-28. DAC Biquad Filter Coefficients

Filter	Coefficient	Left DAC Channel	Right DAC Channel	Default (Reset) Values
Biquad A	N0	Page 8/registers 2–3	Page 8/registers 66–67	0x7FFF (decimal 1.0 – LSB value)
	N1	Page 8/registers 4–5	Page 8/registers 68–69	0x0000
	N2	Page 8/registers 6–7	Page 8/registers 70–71	0x0000
	D1	Page 8/registers 8–9	Page 8/registers 72–73	0x0000
	D2	Page 8/registers 10–11	Page 8/registers 74–75	0x0000
Biquad B	N0	Page 8/registers 12–13	Page 8/registers 76–77	0x7FFF (decimal 1.0 – LSB value)
	N1	Page 8/registers 14–15	Page 8/registers 78–79	0x0000
	N2	Page 8/registers 16–17	Page 8/registers 80–81	0x0000
	D1	Page 8/registers 18–19	Page 8/registers 82–83	0x0000
	D2	Page 8/registers 20–21	Page 8/registers 84–85	0x0000
Biquad C	N0	Page 8/registers 22–23	Page 8/registers 86–87	0x7FFF (decimal 1.0 – LSB value)
	N1	Page 8/registers 24–25	Page 8/registers 88–89	0x0000
	N2	Page 8/registers 26–27	Page 8/registers 90–91	0x0000
	D1	Page 8/registers 28–29	Page 8/registers 92–93	0x0000
	D2	Page 8/registers 30–31	Page 8/registers 94–95	0x0000
Biquad D	N0	Page 8/registers 32–33	Page 8/registers 96–97	0x7FFF (decimal 1.0 – LSB value)
	N1	Page 8/registers 34–35	Page 8/registers 98–99	0x0000
	N2	Page 8/registers 36–37	Page 8/registers 100–101	0x0000
	D1	Page 8/registers 38–39	Page 8/registers 102–103	0x0000
	D2	Page 8/registers 40–41	Page 8/registers 104–105	0x0000
Biquad E	N0	Page 8/registers 42–43	Page 8/registers 106–107	0x7FFF (decimal 1.0 – LSB value)
	N1	Page 8/registers 44–45	Page 8/registers 108–109	0x0000
	N2	Page 8/registers 46–47	Page 8/registers 110–111	0x0000
	D1	Page 8/registers 48–49	Page 8/registers 112–113	0x0000
	D2	Page 8/registers 50–51	Page 8/registers 114–115	0x0000
Biquad F	N0	Page 8/registers 52–53	Page 8/registers 116–117	0x7FFF (decimal 1.0 – LSB value)
	N1	Page 8/registers 54–55	Page 8/registers 118–119	0x0000
	N2	Page 8/registers 56–57	Page 8/registers 120–121	0x0000
	D1	Page 8/registers 58–59	Page 8/registers 122–123	0x0000
	D2	Page 8/registers 60–61	Page 8/registers 124–125	0x0000

5.6.1.4 DAC Interpolation Filter Characteristics

5.6.1.4.1 Interpolation Filter A

Filter A is designed for an f_s up to 48 kps with a flat pass band of 0 kHz–20 kHz.

Table 5-29. Specification for DAC Interpolation Filter A

Parameter	Condition	Value (Typical)	Unit
Filter-gain pass band	0 ... 0.45 f_s	±0.015	dB
Filter-gain stop band	0.55 f_s ... 7.455 f_s	–65	dB
Filter group delay		21/ f_s	s

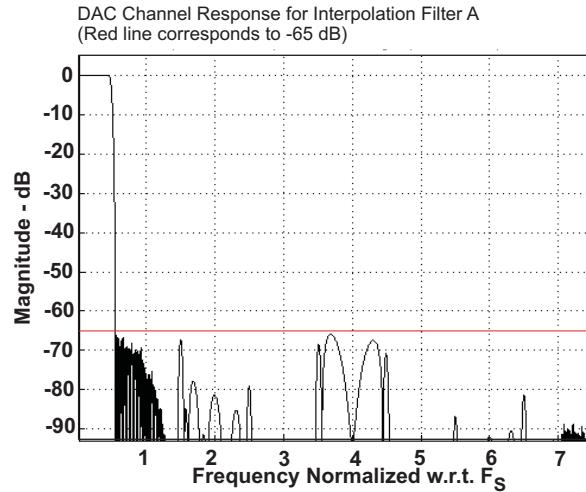

Figure 5-30. Frequency Response of DAC Interpolation Filter A

5.6.1.4.2 Interpolation Filter B

Filter B is specifically designed for an f_S up to 96 kps. Thus, the flat pass-band region easily covers the required audio band of 0 kHz–20 kHz.

Table 5-30. Specification for DAC Interpolation Filter B

Parameter	Condition	Value (Typical)	Unit
Filter-gain pass band	$0 \dots 0.45 f_S$	± 0.015	dB
Filter-gain stop band	$0.55 f_S \dots 3.45 f_S$	-58	dB
Filter group delay		$18/f_S$	s

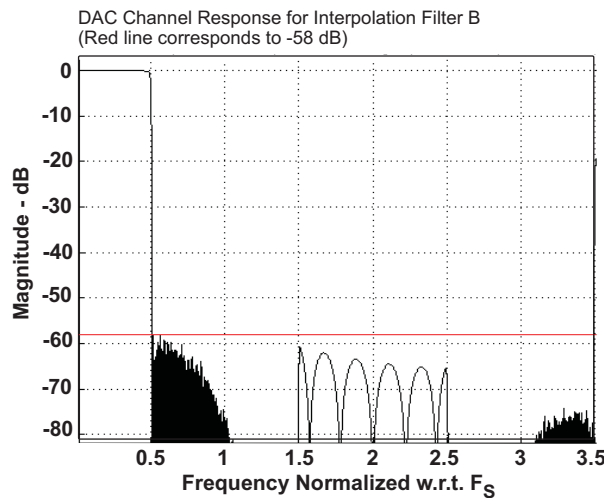

Figure 5-31. Frequency Response of Channel Interpolation Filter B

5.6.1.4.3 Interpolation Filter C

Filter C is specifically designed for the 192-kps mode. The pass band extends up to $0.4 \times f_S$ (corresponds to 80 kHz), more than sufficient for audio applications.

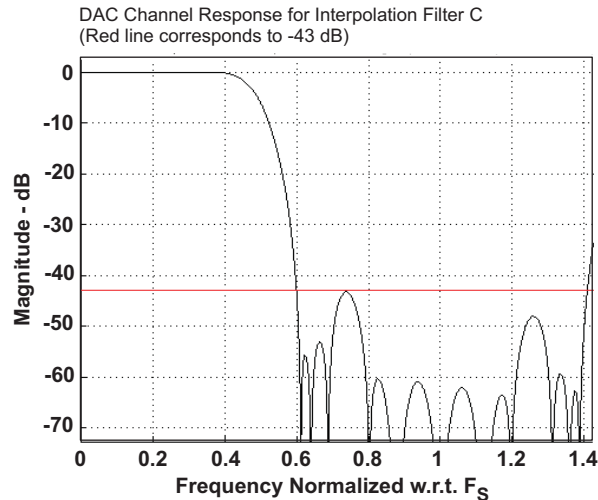

Figure 5-32. Frequency Response of DAC Interpolation Filter C

Table 5-31. Specification for DAC Interpolation Filter C

Parameter	Condition	Value (Typical)	Unit
Filter-gain pass band	0 ... 0.35 f_s	± 0.03	dB
Filter-gain stop band	0.6 f_s ... 1.4 f_s	-43	dB
Filter group delay		13/ f_s	s

5.6.2 DAC Digital-Volume Control

The DAC has a digital-volume control block which implements programmable gain. Each channel has an independent volume control that can be varied from 24 dB to -63.5 dB in 0.5-dB steps. The left-channel DAC volume can be controlled by writing to page 0/register 65, bits D7–D0. The right-channel DAC volume can be controlled by writing to page 0/register 66, bits D7–D0. DAC muting and setting up a master gain control to control both channels is done by writing to page 0/register 64, bits D3–D0. The gain is implemented with a soft-stepping algorithm, which only changes the actual volume by 0.125 dB per input sample, either up or down, until the desired volume is reached. The rate of soft-stepping can be slowed to one step per two input samples by writing to page 0/register 63, bits D1–D0. Note that the default source for volume-control level settings is control by register writes (page 0/registers 65 and 66 to control volume). Use of the VOL/MICDET pin to control the DAC volume is ignored until the volume control source selected has been changed to pin control (page 0/register 116, bit D7 = 1). This functionality is shown in [Figure 1-1](#).

During soft-stepping, the host does not receive a signal when the DAC has been completely muted. This may be important if the host must mute the DAC before making a significant change, such as changing sample rates. In order to help with this situation, the device provides a flag back to the host via a read-only register, page 0/register 38, bit D4 for the left channel and bit D0 for the right channel. This information alerts the host when the part has completed the soft-stepping, and the actual volume has reached the desired volume level. The soft-stepping feature can be disabled by writing to page 0/register 63, bits D1–D0.

If soft-stepping is enabled, the CODEC_CLKIN signal should be kept active until the DAC power-up flag is cleared. When this flag is cleared, the internal DAC soft-stepping process is complete, and CODEC_CLKIN can be stopped if desired. (The analog volume control can be ramped down using an internal oscillator.)

5.6.3 Volume-Control Pin

The range of voltages used by the 7-bit SAR ADC is shown in the [Electrical Characteristics](#) table.

The volume-control pin is not enabled by default but it can be enabled by writing 1 to page 0/register 116, bit D7. The default DAC volume control uses software control of the volume, which occurs if page 0/register 116, bit D7 = 0. Soft-stepping the volume level is set up by writing to page 0/register 63, bits D1–D0.

When the volume-pin function is used, a 7-bit Vol ADC reads the voltage on the VOL/MICDET pin and updates the digital volume control. (It overwrites the current value of the volume control.) The new volume setting which has been applied due to a change of voltage on the volume control pin can be read on page 0/register 117, bits D6–D0. The 7-bit Vol ADC clock source can be selected on page 0/register 116, bit D6. The update rate can be programmed on page 0/register 116, bits D2–D0 for this 7-bit SAR ADC.

The VOL/MICDET pin gainmapping is shown in [Table 5-32](#).

Table 5-32. VOL/MICDET Pin Gain Mapping

VOL/MICDET PIN SAR OUTPUT	DIGITAL GAIN APPLIED
0	18 dB
1	17.5 dB
2	17 dB
:	:
35	0.5 dB
36	0.0 dB
37	–0.5 dB
:	:
89	–26.5 dB
90	–27 dB
91	–28 dB
:	:
125	–62 dB
126	–63 dB
127	Mute

The VOL/MICDET pin connection and functionality are shown in [Figure 5-33](#).

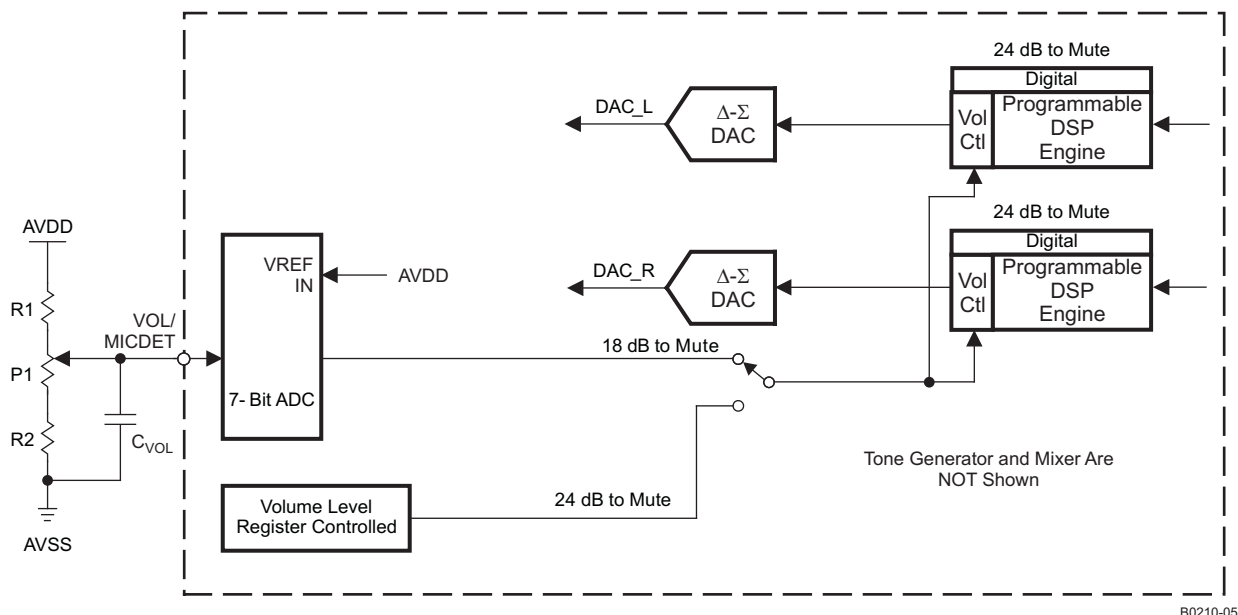

Figure 5-33. Digital Volume Controls for Beep Generator and DAC Play Data

As shown in [Table 5-32](#), the VOL/MICDET pin has a range of volume control from 18 dB down to –63 dB, and mute. However, if less maximum gain is required, then a smaller range of voltage should be applied to the VOL/MICDET pin. This can be done by increasing the value of R2 relative to the value of (P1 + R1), so that more voltage is available at the bottom of P1. The circuit should also be designed such that for the values of R1, R2, and P1 chosen, the maximum voltage (top of the potentiometer) does not exceed AVDD/2 (see [Figure 5-33](#)). The recommended values for R1, R2, and P1 for several maximum gains are shown in [Table 5-33](#). Note that in typical applications, R1 should not be 0 Ω, as the VOL/MICDET pin should not exceed AVDD/2 for proper ADC operation.

Table 5-33. VOL/MICDET Pin Gain Scaling

R1 (kΩ)	P1 (kΩ)	R2 (kΩ)	ADC VOLTAGE for AVDD = 3.3 V (V)	DIGITAL GAIN RANGE (dB)
25	25	0	0 V to 1.65 V	18 dB to –63 dB
33	25	7.68	0.386 V to 1.642 V	3 dB to –63 dB
34.8	25	9.76	0.463 V to 1.649 V	0 dB to –63 dB

5.6.4 Dynamic Range Compression

Typical music signals are characterized by crest factors, the ratio of peak signal power to average signal power, of 12 dB or more. To avoid audible distortions due to clipping of peak signals, the gain of the DAC channel must be adjusted so as not to cause hard clipping of peak signals. As a result, during nominal periods, the applied gain is low, causing the perception that the signal is not loud enough. To overcome this problem, DRC in the TSC2117 continuously monitors the output of the DAC digital volume control to detect its power level relative to 0 dBFS. When the power level is low, DRC increases the input signal gain to make it sound louder. At the same time, if a peaking signal is detected, it autonomously reduces the applied gain to avoid hard clipping. This results in sounds more pleasing to the ear as well as sounding louder during nominal periods.

The DRC functionality in the TSC2117 is implemented by a combination of processing blocks in the DAC channel as described in [Section 5.6.1.2](#).

DRC can be disabled by writing to page 0/register 68, bits D6–D5.

DRC typically works on the filtered version of the input signal. The input signals have no audio information at dc and extremely low frequencies; however, they can significantly influence the energy estimation function in DRC. Also, most of the information about signal energy is concentrated in the low-frequency region of the input signal.

To estimate the energy of the input signal, the signal is first fed to the DRC high-pass filter and then to the DRC low-pass filter. These filters are implemented as first-order IIR filters given by

$$H_{\text{HPF}}(z) = \frac{N_0 + N_1 z^{-1}}{2^{15} - D_1 z^{-1}} \quad (6)$$

$$H_{\text{LPF}}(z) = \frac{N_0 + N_1 z^{-1}}{2^{15} - D_1 z^{-1}} \quad (7)$$

The coefficients for these filters are 16 bits wide in 2s-complement format and are user-programmable through register write as given in [Table 5-34](#)

Table 5-34. DRC HPF and LPF Coefficients

Coefficient	Location
HPF N0	C71 page 9/registers 14 to 15
HPF N1	C72 page 9/registers 16 to 17
HPF D1	C73 page 9/registers 18 to 19
LPF N0	C74 page 9/registers 20 to 21
LPF N1	C75 page 9/registers 22 to 23
LPF D1	C76 page 9/registers 24 to 25

The default values of these coefficients implement a high-pass filter with a cutoff at $0.00166 \times \text{DAC}_f_s$, and a low-pass filter with a cutoff at $0.00033 \times \text{DAC}_f_s$.

The output of the DRC high-pass filter is fed to the processing block selected for the DAC channel. The absolute value of the DRC-LPF filter is used for energy estimation within the DRC.

The gain in the DAC digital volume control is controlled by page 0/registers 65 and 66. When the DRC is enabled, the applied gain is a function of the digital volume control register setting and the output of the DRC.

The DRC parameters are described in sections that follow.

5.6.4.1 DRC Threshold

The DRC threshold represents the level of the DAC playback signal at which the gain compression becomes active. The output of the digital volume control in the DAC is compared with the set threshold. The threshold value is programmable by writing to page 0/register 68, bits D4–D2. The threshold value can be adjusted between –3 dBFS and –24 dBFS in steps of 3 dB. Keeping the DRC threshold value too high may not leave enough time for the DRC block to detect peaking signals, and can cause excessive distortion at the outputs. Keeping the DRC threshold value too low can limit the perceived loudness of the output signal.

The recommended DRC threshold value is –24 dB.

When the output signal exceeds the set DRC threshold, the interrupt flag bits at page 0/register 44, bits D3–D2 are updated. These flag bits are *sticky* in nature, and are reset only after they are read back by the user. The non-sticky versions of the interrupt flags are also available at page 0/register 46, bits D3–D2.

5.6.4.2 DRC Hysteresis

DRC hysteresis is programmable by writing to page 0/register 68, bits D1–D0. These bits can be programmed to represent values between 0 dB and 3 dB in steps of 1dB. It is a programmable window around the programmed DRC threshold that must be exceeded for disabled DRC to become enabled, or enabled DRC to become disabled. For example, if the DRC threshold is set to –12 dBFS and the DRC hysteresis is set to 3 dB, then if the gain compression in DRC is inactive, the output of the DAC digital volume control must exceed –9 dBFS before gain compression due to the DRC is activated. Similarly, when the gain compression in the DRC is active, the output of the DAC digital volume control must fall below –15 dBFS for gain compression in the DRC to be deactivated. The DRC hysteresis feature prevents the rapid activation and de-activation of gain compression in DRC in cases when the output of the DAC digital volume control rapidly fluctuates in a narrow region around the programmed DRC threshold. By programming the DRC hysteresis as 0 dB, the hysteresis action is disabled.

The recommended value of DRC hysteresis is 3 dB.

5.6.4.3 DRC Hold

The DRC hold is intended to slow the start of decay for a specified period of time in response to a decrease in energy level. To minimize audible artifacts, it is recommended to set the DRC hold time to 0 through programming page 0/register 69, bits D6–D3 = 0000.

5.6.4.4 DRC Attack Rate

When the output of the DAC digital volume control exceeds the programmed DRC threshold, the gain applied in the DAC digital volume control is progressively reduced to avoid the signal from saturating the channel. This process of reducing the applied gain is called *attack*. To avoid audible artifacts, the gain is reduced slowly with a rate equaling the attack rate, programmable via page 0/register 70, bits D7–D4. Attack rates can be programmed from 4-dB gain change per $1/\text{DAC}_{f_s}$ to $1.2207\text{e-}5$ -dB gain change per $1/\text{DAC}_{f_s}$.

Attack rates should be programmed such that before the output of the DAC digital volume control can clip, the input signal should be sufficiently attenuated. High attack rates can cause audible artifacts, and too-slow attack rates may not be able to prevent the input signal from clipping.

The recommended DRC attack rate value is $1.9531\text{e-}4$ dB per $1/\text{DAC}_{f_s}$.

5.6.4.5 DRC Decay Rate

When the DRC detects a reduction in output signal swing beyond the programmed DRC threshold, the DRC enters a decay state, where the applied gain in the digital-volume control is gradually increased to programmed values. To avoid audible artifacts, the gain is slowly increased with a rate equal to the decay rate programmed through page 0/register 70, bits D3–D0. The decay rates can be programmed from $1.5625\text{e-}3$ dB per $1/\text{DAC}_{f_s}$ to $4.7683\text{e-}7$ dB per $1/\text{DAC}_{f_s}$. If the decay rates are programmed too high, then sudden gain changes can cause audible artifacts. However, if it is programmed too slow, then the output may be perceived as too low for a long time after the peak signal has passed.

The recommended Value of DRC attack rate is $2.4414\text{e-}5$ dB per $1/\text{DAC}_{f_s}$.

5.6.4.6 Example Setup for DRC

- PGA Gain = 12 dB
- Threshold = –24 dB
- Hysteresis = 3 dB
- Hold time = 0 ms
- Attack Rate = $1.9531\text{e-}4$ dB per $1/\text{DAC}_{f_s}$
- Decay Rate = $2.4414\text{e-}5$ dB per $1/\text{DAC}_{f_s}$

Script

```
#Go to Page 0 w 30 00 00 #DAC => 12 db gain left w 30 41 18 #DAC => 12 db gain right w 30 42 18
#DAC => DRC Enabled for both channels, Threshold = -
24 db, Hysteresis = 3 dB w 30 44 7F #DRC Hold = 0 ms, Rate of Changes of Gain = 0.5 dB/Fs' w 30
45 00 #Attack Rate = 1.9531e-4 dB/Frame , DRC Decay Rate =2.4414e-
5 dB/Frame w 30 46 B6 #Go to Page 9 w 30 00 09 #DRC HPF w 30 0E 7F AB 80 55 7F 56 #DRC LPF W 30
14 00 11 00 11 7F DE
```

5.6.4.7 Headset Detection

The TSC2117 includes extensive capability to monitor a headphone, microphone, or headset jack, to determine if a plug has been inserted into the jack, and then determine what type of headset/headphone is wired to the plug. The device also includes the capability to detect a button press, even, for example, when starting calls on mobile phones with headsets. Figure 5-34 shows the circuit configuration to enable this feature.

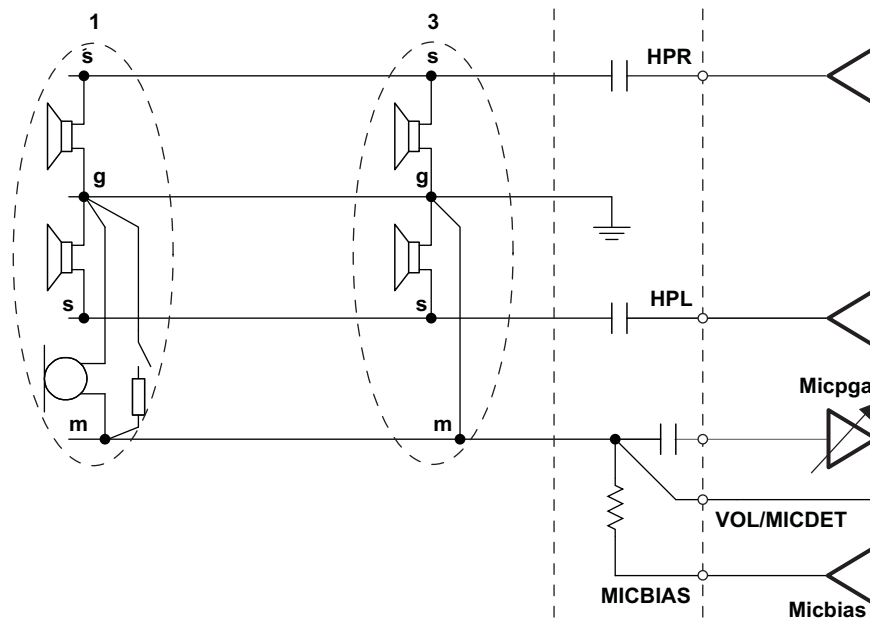

Figure 5-34. Jack Connections for Headset Detection

This feature is enabled by programming page 0/register 67, bit D1. In order to avoid false detections due to mechanical vibrations in headset jacks or microphone buttons, a debounce function is provided for glitch rejection. For the case of headset insertion, a debounce function with a range of 32 ms to 512 ms is provided. This can be programmed via page 0/register 67, bits D4–D2. For improved button-press detection, the debounce function has a range of 8 ms to 32 ms by programming page 0/register 67, bits D1–D0.

The TSC2117 also provides feedback to user when a button press or a headset insertion/removal event is detected through register-readable flags as well as an interrupt on the I/O pins. The value in page 0/register 46, bits D5–D4 provides the instantaneous state of button press and headset insertion. Page 0/register 44, bit D5 is a sticky (latched) flag that is set when the button-press event is detected. Page 0/register 44, bit D4 is a sticky flag which is set when the headset insertion or removal event is detected. These sticky flags are set by the event occurrence, and are reset only when read. This requires polling page 0/register 44. To avoid polling and the associated overhead, the TSC2117 also provides an interrupt feature whereby the events can trigger the INT1 and/or INT2 interrupts. These interrupt events can be routed to one of the digital output pins. See Section 5.6.4.8 for details.

The TSC2117 not only detects a headset insertion event, but also is able to distinguish between the different headsets inserted, such as stereo headphones or cellular headphones. After the headset-detection event, the user can read page 0/register 67, bits D6–D5 to determine the type of headset inserted.

Table 5-35. Headset-Detection Block Registers

Register	Description
Page 0/register 67, bit D1	Headset-detection enable/disable
Page 0/register 67, bits D4–D2	Debounce programmability for headset detection
Page 0/register 67, bits D1–D0	Debounce programmability for button press
Page 0/register 44, bit D5	Sticky flag for button-press event
Page 0/register 44, bit D4	Sticky flag for headset-insertion or -removal event
Page 0/register 46, bit D5	Status flag for button-press event
Page 0/register 46, bit D4	Status flag for headset insertion and removal
Page 0/register 67, bits D6–D5	Flags for type of headset detected

The headset detection block requires AVDD to be powered. The headset detection feature in the TSC2117 is achieved with very low power overhead, requiring less than 20 μ A of additional current from the AVDD supply.

5.6.4.8 Interrupts

Some specific events in the TSC2117 which may require host processor intervention, can be used to trigger interrupts to the host processor. This avoids polling the status-flag registers continuously. The TSC2117 has two defined interrupts, INT1 and INT2, that can be configured by programming page 0/registers 48 and 49. A user can configure interrupts INT1 and INT2 to be triggered by one or many events, such as:

- Headset detection
- Button press
- DAC DRC signal exceeding threshold
- Noise detected by AGC
- Overcurrent condition in headphone drivers/speaker drivers
- Data overflow in ADC and DAC processing blocks and filters
- DC measurement data available
- SAR measurement data available
- Touch detection

Each of these INT1 and INT2 interrupts can be routed to output pins like GPIO1, GPIO2, SDOUT, and MISO by configuring the respective output control registers in page 0/registers 51, 52, 53, and 55. These interrupt signals can either be configured as a single pulse or a series of pulses by programming page 0/register 48, bit D0 and page 0/register 49, bit D0. If the user configures the interrupts as a series of pulses, the events trigger the start of pulses that stop when the flag registers in page 0/registers 44, 45, and 50 are read by the user to determine the cause of the interrupt.

5.6.5 Key-Click Functionality With Beep Generator

A special algorithm has been included in the digital signal processing block for generating a digital sine-wave signal that is sent to the DAC. This functionality is intended for generating key-click sounds for user feedback. The sine-wave generator is very flexible (see [Table 5-36](#)) and is completely register programmable. Programming page 0/registers 71–79 (8 bits each) completely controls the functionality of this generator and allows for differentiating sounds.

The two registers used for programming the 16-bit sine-wave coefficient are page 0/registers 76 and 77. The two registers used for programming the 16-bit cosine-wave coefficient are page 0/registers 78 and 79. This coefficient resolution allows virtually any frequency of sine wave in the audio band to be generated, up to $f_s/2$.

The three registers used to control the length of the sine-burst waveform are page 0/registers 73–75. The resolution (bit) in the registers of the sine-burst length is one sample time, so this allows great control on the overall time of the sine-burst waveform. This 24-bit length timer supports 16,777,215 sample times. (For example, if f_s is set at 48 kHz, and the register value equals 96,000d (01 7700h), then the sine burst lasts exactly 2 seconds.) The default settings for the tone generator, based on using a sample rate of 48 kHz, are 1-kHz (approximately) sine wave, with a sine-burst length of five cycles (5 ms).

Table 5-36. Beep Generator Register Locations (Page 00h)

REGISTER	LEFT BEEP CONTROL	RIGHT BEEP CONTROL	BEEP LENGTH			SINE		COSINE	
			MSB	MID	LSB	MSB	LSB	MSB	LSB
	71	72	73	74	75	76	77	78	79

Table 5-37. Example Beep-Generator Settings for a 1000-Hz Tone

BEEP FREQUENCY	BEEP LENGTH			SINE		COSINE		SAMPLE RATE
Hz	MSB (hex)	MID (hex)	LSB (hex)	MSB (hex)	LSB (hex)	MSB (hex)	LSB (hex)	Hz
1000 ⁽¹⁾	0	0	EE	10	D8	7E	E3	48,000

(1) These are the default settings.

Two registers are used to control the left sine-wave volume and the right sine-wave volume independently. The 6-bit digital volume control used allows level control of 2 dB to –61 dB in 1-dB steps. The left-channel volume is controlled by writing to page 0/register 71, bits D5–D0. The right-channel volume is controlled by writing to page 0, register 72, bits D5–D0. A master volume control that controls the left and right channels of the beep generator can be set up by writing to page 0/register 72, bits D7–D6. The default volume control setting is 2 dB, which provides the maximum tone-generator output level.

For generating other tones, the three tone-generator coefficients can be found by running the following script using MATLAB™ :

```
Sine = dec2hex(round(sin(2*pi*Fin/Fs)*2^15)) Cosine =
dec2hex(round(cos(2*pi*Fin/Fs)*2^15)) Beep Length =
dec2hex(floor(Fs*Cycle/Fin))
```

where,

f_{in} = Beep frequency desired.

f_s = Sample rate.

Cycle = Number of beep (sine wave) cycles that are needed.

dec2hex = Decimal to Hexadecimal conversion function.

NOTES:

- f_{in} should be less than $f_s/4$.
- For the sine and cosine values, if the number of bits is less than the full 16-bit value, then the unused MSBs must be written as 0s.
- For the beep-length values, if number of bits is less than the full 24-bit value, then the unused MSBs must be written as 0s.

Following the beep volume control is a digital mixer that mixes in a playback data stream whose level has already been set by the DAC volume control. Therefore, once the key-click volume level is set, the key-click volume is not affected by the DAC volume control, which is the main control available to the end user. This functionality is shown in [Figure 1-1](#).

Following the DAC, the signal can be further scaled by the analog output volume control and power amplifier level control.

The beep generator (used for key-click function) can be operated in two modes, manual and automatic mode. In manual mode, a single beep is generated by writing to page 0/register 71, bit D7. After the programmed beep length has finished, register 71, bit D7 is reset back to zero. In the automatic mode, a beep occurs at the transition of PEN DOWN detection; however, a beep does not occur at the transition of PEN UP detection. The automatic mode is disabled by default. Automatic mode can be enabled by writing to page 0/register 71, bit D6. This functionality is shown in [Figure 5-36](#). To minimize the risk of erroneous beeps occurring, the PEN UP debounce is applied as programmed on page 3/register 18, bits D2–D0.

5.6.6 Programming DAC Digital Filter Coefficients

The digital filter coefficients must be programmed through either the I²C or SPI interface. All digital filtering for the DAC signal path must be loaded into the RAM before the DAC is powered on. (Note that default ALLPASS filter coefficients for programmable biquads are located in boot ROM. The boot ROM automatically loads the default values into the RAM following a hardware reset (toggling the $\overline{\text{RESET}}$ pin) or after a software reset. After resetting the device, loading boot ROM coefficients into the digital filters requires 100 μs of programming time. During this time, reading or writing to page 8 through page 15 for updating DAC filter coefficient values is not permitted. (The DAC should not be powered up until after all of the DAC configurations have been done by the system microprocessor.)

5.6.7 Updating DAC Digital Filter Coefficients During PLAY

When it is required to update the DAC digital filter coefficients or beep generator during play, care must be taken to avoid click and pop noise or even a possible oscillation noise. These artifacts can occur if the DAC coefficients are updated without following the proper update sequence. The correct sequence is shown in [Figure 5-35](#). The values for times listed in [Figure 5-35](#) are conservative and should be used for software purposes.

There is also an adaptive mode, in which DAC coefficients can be updated while the DAC is on. For details, see [Section 5.6.1.3](#).

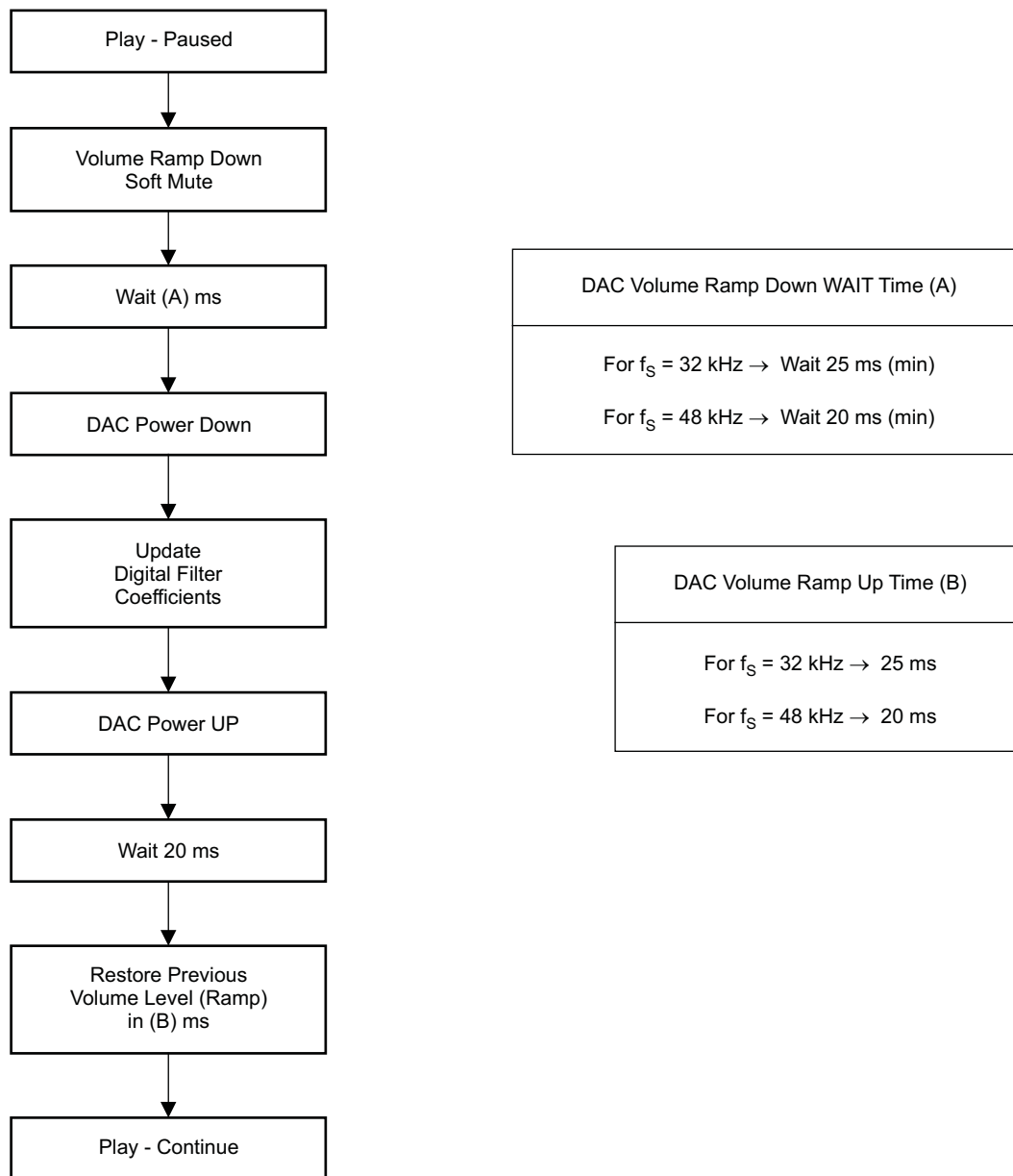

F0024-02

Figure 5-35. Example Flow For Updating DAC Digital Filter Coefficients During Play

5.6.8 Digital Mixing and Routing

The TSC2117 has four digital mixing blocks. Each mixer can provide either mixing or multiplexing of the digital audio data. This arrangement of digital mixers allows independent volume control for both the playback data and the key-click sound. The first set of mixers can be used to make monaural signals from left and right audio data, or they can even be used to swap channels to the DAC. This function is accomplished by selecting left audio data for the right DAC input, and right data for the left DAC input. The second set of mixers provides mixing of the audio data stream and the key-click sound. The digital routing can be configured by writing to page 0/register 63, bits D5–D4 for the left channel and bits D3–D2 for the right channel.

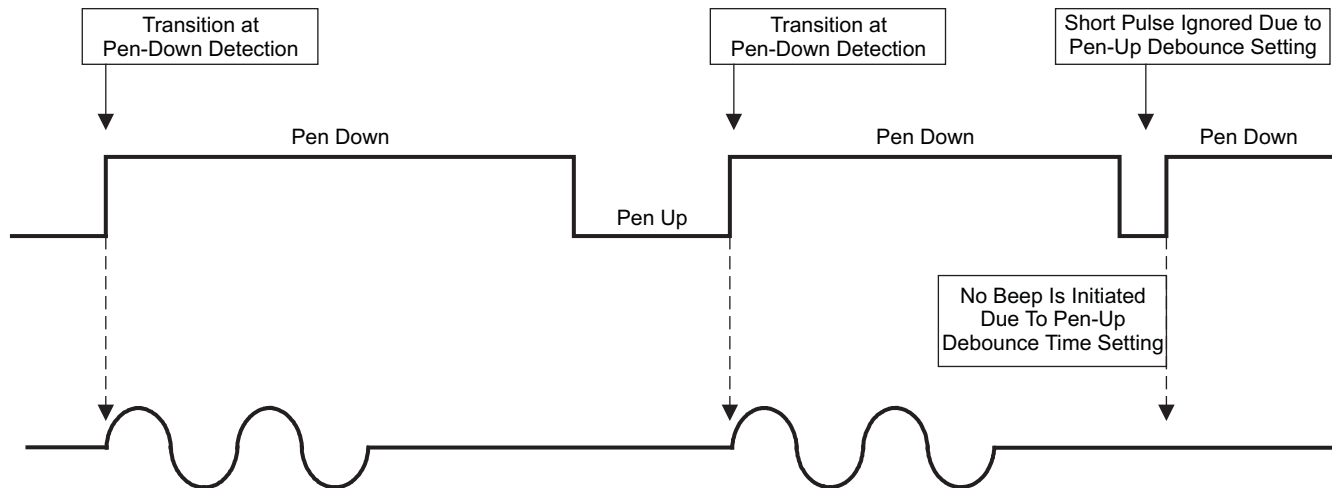

T0203-01

Figure 5-36. Automatic Beep Mode With Pen-Up Debounce Enabled

Because the key click function uses the digital signal processing block, the CODEC_CLKIN, DAC, analog volume control, and output driver must be powered on for the key-click sound to occur.

5.6.9 Analog Audio Routing

The TSC2117 has the capability to route the DAC output to either the headphone or the speaker output. If desirable, both output drivers can be operated at the same time while playing at different volume levels. The TSC2117 provides various digital routing capabilities, allowing digital mixing or even channel swapping in the digital domain. All analog outputs other than the selected ones can be powered down for optimal power consumption.

5.6.9.1 Analog Output Volume Control

The output volume control can be used to fine-tune the level of the mixer amplifier signal supplied to the headphone driver or the speaker driver. This architecture supports separate and concurrent volume levels for each of the four output drivers. This volume control can also be used as part of the output pop-noise reduction scheme. This feature is available even if the ADC and DAC are powered down.

5.6.9.2 Headphone Analog Output Volume Control

For the headphone outputs, the analog volume control has a range from 0 dB to –78 dB in 0.5-dB steps for most of the useful range plus mute, which is shown in [Table 5-38](#). This volume control includes soft-stepping logic. Routing the left-channel DAC output signal to the left-channel analog volume control is done by writing to page 1/register 35, bit D6. Routing the right-channel DAC output signal to the right-channel analog volume control is done by writing to page 1/register 35, bit D2.

Changing the left-channel analog volume for the headphone is controlled by writing to page 1/register 36, bits D6–D0. Changing the right-channel analog volume for the headphone is controlled by writing to page 1/register 37, bits D6–D0. Routing the signal from the output of the left-channel analog volume control to the input of the left-channel headphone power amplifier is done by writing to page 1/register 36, bit D7. Routing the signal from the output of the right-channel analog volume control to the input of the right-channel headphone power amplifier is done by writing to page 1/register 37, bit D7.

The analog volume-control soft-stepping time is based on the setting in page 0/register 63, bits D1–D0.

Table 5-38. Analog Volume Control for Headphone and Speaker Outputs (for D7 = 1)⁽¹⁾

Register Value (D6–D0)	Analog Gain (dB)	Register Value (D6–D0)	Analog Gain (dB)	Register Value (D6–D0)	Analog Gain (dB)	Register Value (D6–D0)	Analog Gain (dB)
0	0	30	–15	60	–30.1	90	–45.2
1	–0.5	31	–15.5	61	–30.6	91	–45.8
2	–1	32	–16	62	–31.1	92	–46.2
3	–1.5	33	–16.5	63	–31.6	93	–46.7
4	–2	34	–17	64	–32.1	94	–47.4
5	–2.5	35	–17.5	65	–32.6	95	–47.9
6	–3	36	–18.1	66	–33.1	96	–48.2
7	–3.5	37	–18.6	67	–33.6	97	–48.7
8	–4	38	–19.1	68	–34.1	98	–49.3
9	–4.5	39	–19.6	69	–34.6	99	–50
10	–5	40	–20.1	70	–35.2	100	–50.3
11	–5.5	41	–20.6	71	–35.7	101	–51
12	–6	42	–21.1	72	–36.2	102	–51.4
13	–6.5	43	–21.6	73	–36.7	103	–51.8
14	–7	44	–22.1	74	–37.2	104	–52.2
15	–7.5	45	–22.6	75	–37.7	105	–52.7
16	–8	46	–23.1	76	–38.2	106	–53.7
17	–8.5	47	–23.6	77	–38.7	107	–54.2
18	–9	48	–24.1	78	–39.2	108	–55.3
19	–9.5	49	–24.6	79	–39.7	109	–56.7
20	–10	50	–25.1	80	–40.2	110	–58.3
21	–10.5	51	–25.6	81	–40.7	111	–60.2
22	–11	52	–26.1	82	–41.2	112	–62.7
23	–11.5	53	–26.6	83	–41.7	113	–64.3
24	–12	54	–27.1	84	–42.1	114	–66.2
25	–12.5	55	–27.6	85	–42.7	115	–68.7
26	–13	56	–28.1	86	–43.2	116	–72.2
27	–13.5	57	–28.6	87	–43.8	117–127	–78.3
28	–14	58	–29.1	88	–44.3		
29	–14.5	59	–29.6	89	–44.8		

(1) Mute when D7 = 0 and D6–D0 = 127 (0x7F)

5.6.9.3 Class-D Speaker Analog Output Volume Control

For the speaker outputs, the analog volume control has a range from 0 dB to –78 dB in 0.5-dB steps for most of the useful range plus mute, as seen in [Table 5-38](#). The implementation includes soft-stepping logic.

Routing the left-channel DAC output signal to the left-channel analog volume control is done by writing to page 1/register 35, bit D6. Routing the right-channel DAC output signal to the right-channel analog volume control is done by writing to page 1/register 35, bit D2. Changing the left-channel analog volume for the speaker is controlled by writing to page 1/register 38, bits D6–D0. Changing the right-channel analog volume for the speaker is controlled by writing to page 1/register 39, bits D6–D0.

Routing the signal from the output of the left-channel analog volume control to the input of the left-channel speaker amplifier is done by writing to page 1/register 38, bit D7. Routing the signal from the output of the right-channel analog volume control to the input of the right-channel speaker amplifier is done by writing to page 1/register 39, bit D7.

The analog volume-control soft-stepping time is based on the setting in page 0/register 63, bits D1–D0.

5.6.10 Analog Outputs

Various analog routings are supported for playback. All the options can be conveniently viewed on the functional block diagram, [Figure 1-1](#).

5.6.10.1 Headphone Drivers

The TSC2117 features a stereo headphone driver (HPL and HPR) that can deliver up to 30 mW per channel, at 3.3 V supply voltage, into a 16- Ω load. The headphones are used in a single-ended configuration where an ac coupling capacitor (dc blocking) is connected between the device output pins and the headphones. The headphone driver also supports 32- Ω and 10-k Ω loads without changing any control register settings.

The headphone drivers can be configured to optimize the power consumption in the lineout-drive mode by writing 11 to page 1/register 44, bits D2–D1.

The output common mode of the headphone/lineout drivers can be programmed to 1.35 V, 1.5 V, 1.65 V, or 1.8 V by setting page 1/register 31, bits D4–D3. The common-mode voltage should be set $\leq AVDD/2$.

The left headphone driver can be powered on by writing to page 1/register 31, bit D7. The right headphone driver can be powered on by writing to page 1/register 31, bit D6. The left-output driver gain can be controlled by writing to page 1/register 40, bits D6–D3, and it can be muted by writing to page 1/register 40, bit D2. The right-output driver gain can be controlled by writing to page 1/register 41, bits D6–D3, and it can be muted by writing to page 1/register 41, bit D2.

The TSC2117 has a short-circuit protection feature for the headphone drivers, which is always enabled to provide protection. The output condition of the headphone driver during short circuit can be programmed by writing to page 1/register 31, bit D1. If D1 = 0 when a short circuit is detected, the device limits the maximum current to the load. If D1 = 1 when a short circuit is detected, the device powers down the output driver. The default condition for headphones is the current-limiting mode. In case of a short circuit on either channel, the output is disabled and a status flag is provided as read-only bits on page 1/register 31, bit D0. If shutdown mode is enabled, then as soon as the short circuit is detected, page 1/register 31, bit D7 (for HPL) and/or page 1/register 31, bit D6 (for HPR) clears automatically. Next, the device requires a reset to re-enable the output stage. Resetting can be done in two ways. First, the device master reset can be used, which requires either toggling the \overline{RESET} pin or using the software reset. If master reset is used, it resets all of the registers. Second, a dedicated headphone power-stage reset can also be used to re-enable the output stage, and that keeps all of the other device settings. The headphone power stage reset is done by setting page 1/register 31, bit D7 for HPL and by setting page 1/register 31, bit D6 for HPR. If the fault condition has been removed, then the device returns to normal operation. If the fault is still present, then another shutdown occurs. Repeated resetting (more than three times) is not recommended, as this could lead to overheating.

5.6.10.2 Speaker Drivers

The TSC2117 has an integrated class-D stereo speaker driver (SPLP/SPLN and SPRP/SPRN) capable of driving an 8- Ω differential load. The speaker driver can be powered directly from the battery supply (2.7 V to 5.5 V) on the SLVDD and SRVDD pins; however, the voltage (including spike voltage) must be limited below the absolute-maximum voltage of 6 V.

The speaker driver is capable of supplying 400 mW per channel with a 3.6-V power supply. Through the use of digital mixing, the device can connect one or both digital audio playback data channels to either speaker driver; this also allows digital channel swapping if needed.

The left class-D speaker driver can be powered on by writing to page 1/register 32, bit D7. The right class-D speaker driver can be powered on by writing to page 1/register 32, bit D6. The left-output driver gain can be controlled by writing to page 1/register 42, bits D4–D3, and it can be muted by writing to page 1/register 42, bit D2. The right-output driver gain can be controlled by writing to page 1/register 43, bits D4–D3, and it can be muted by writing to page 1/register 43, bit D2.

The TSC2117 has a short-circuit protection feature for the speaker drivers that is always enabled to provide protection. If the output is shorted, the output stage shuts down on the overcurrent condition. (Current limiting is not an available option for the higher-current speaker driver output stage.) In case of a short circuit on either channel, the output is disabled and a status flag is provided as a read-only bit on page 1/register 32, bit D0.

If shutdown occurs due to an overcurrent condition, then the device requires a reset to re-enable the output stage. Resetting can be done in two ways. First, the device master reset can be used, which requires either toggling the $\overline{\text{RESET}}$ pin or using the software reset. If master reset is used, it resets all of the registers. Second, a dedicated speaker power-stage reset can be used that keeps all of the other device settings. The speaker power-stage reset is done by setting page 1/register 32, bit D7 for SPLP and SPLN and by setting page 1/register 32, bit D6 for SPRP and SPRN. If the fault condition has been removed, then the device returns to normal operation. If the fault is still present, then another shutdown occurs. Repeated resetting (more than three times) is not recommended, as this could lead to overheating.

To minimize battery current leakage, the SLVDD and SRVDD voltage levels should not be less than the AVDD voltage level.

The TSC2117 has a thermal protection (OTP) feature for the speaker drivers which is always enabled to provide protection. If the device is overheated, then the output stops switching. When the device cools down, the device resumes switching. An overtemperature status flag is provided as a read-only bit on page 0/register 3, bit D1. The OTP feature is for self-protection of the device. If die temperature can be controlled at the system/board level, then overtemperature does not occur.

5.6.11 Register Control or Pin Control for Audio Output-Stage Power-Down Configuration

After the device has been configured (following a $\overline{\text{RESET}}$) and the circuitry has been powered up, the audio output stage can be powered up and powered down either by pin control or by register control. If pin control is used, then the GPI2 pin (configured as $\text{HP}_{\overline{\text{SP}}}$) is used when page 0/register 57, bits D2–D1 = 11.

The GPI2 pin (configured as $\text{HP}_{\overline{\text{SP}}}$) is used to control the selection of power up and power down for the speaker and headphone driver stages. This pin prevents both the headphone and the speaker amplifier from being powered up at the same time. The speaker amplifier is powered when $\text{HP}_{\overline{\text{SP}}} = 0$ and the headphone driver is powered when $\text{HP}_{\overline{\text{SP}}} = 1$.

Register control to enable or disable GPI2 pin is found on page 0/register 57. By default, the GPI2 pin is disabled.

To control the outputs with the pin controls disabled:

- A. To turn on HPL, write a 1 to page 1/register 31, bit D7.
- B. To turn on HPR, write a 1 to page 1/register 31, bit D6.
- C. To turn on SPL, write a 1 to page 1/register 32, bit D7.
- D. To turn on SPR, write a 1 to page 1/register 32, bit D6.

These functions soft-start automatically. By using register control, it is possible to turn all four stages on at the same time without turning two of them off. By pin control, either headphone or speakers can be on at the same time.

5.7 SAR ADC Operation (Touch Screen and Auxiliary)

This section describes how to use the SAR ADC for the functions:

- Four-wire resistive touch screen
- Temperature measurement
- Battery measurement
- Auxiliary voltage measurement

5.7.1 The Four-Wire Resistive Touch Screen

A resistive touch screen works by applying a voltage across a resistor network and measuring the change in resistance at a given point on the matrix where a screen is touched by an input stylus, pen, or finger. The change in the resistance ratio marks the location on the touch screen.

The TSC2117 supports the resistive four-wire configurations (see [Figure 5-37](#)). The circuit determines location in two coordinate-pair dimensions.

A four-wire touch screen is constructed as shown in [Figure 5-37](#). It consists of two transparent resistive layers separated by insulating spacers.

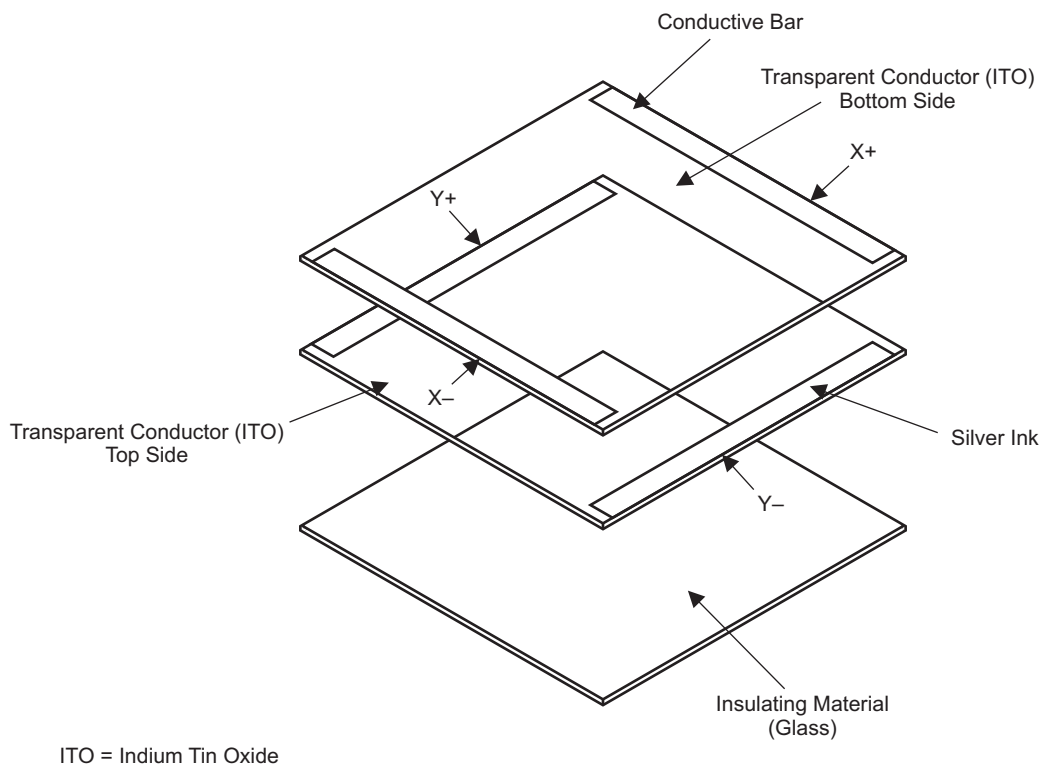

M0068-01

Figure 5-37. Four-Wire Touch-Screen Construction

The four-wire touch-screen panel works by applying a voltage across the vertical or horizontal resistive network. The ADC converts the voltage measured at the point the screen is touched. A measurement of the Y position of the pointing device is made by connecting the X+ input to an ADC, turning on the Y drivers, and digitizing the voltage seen at the X+ input. The voltage measured is determined by the voltage divider developed at the point of touch. For this measurement, the horizontal panel resistance in the X+ lead does not affect the conversion due to the high input impedance of the ADC.

Voltage is then applied to the other axis, and the ADC converts the voltage representing the X position on the screen. This provides the X and Y coordinates to the associated processor.

When the touch screen is pressed or touched and the drivers to the panel are turned on, the voltage across the touch screen often overshoots and then slowly settles (decays) down to a stable dc value. This is due to mechanical bouncing which is caused by vibration of the top layer sheet of the touch screen when it is pressed. This settling time must be accounted for, or else the converted value will be in error. Therefore, a delay must be introduced between the time the driver for a particular measurement is turned on and the time measurement is made.

In some applications, external capacitors may be required across the touch screen for filtering noise picked up by the touch screen, i.e., noise generated by the LCD panel or back-light circuitry. The value of these capacitors provides a low-pass filter to reduce the noise, but causes an additional settling time requirement when the touch-screen panel is touched.

Several solutions to this problem are available in the TSC2117. A programmable delay time is available which sets the delay between turning the drivers on and making a conversion. This is referred to as the panel voltage stabilization time, and is used in some of the modes available in the TSC2117.

The TSC2117 touch screen interface can measure position (X, Y). Determination of these coordinates is possible under two different modes of the ADC:

- Conversion controlled by the TSC2117 is initiated by detection of a touch. In this mode, if touch is detected, then the TSC2117 automatically starts conversion for touch-screen coordinates based on the setting of page 3/register 3, bits D5–D2. After the time set by the interval timer, it checks for the touch again. If touch is still there, it starts conversion for touch-screen coordinates. This process continues.
- Conversion controlled by the TSC2117 is initiated by the host after getting a pen-touch interrupt (Note: program the GPIO1 or GPIO2 pin such that it generates the interrupt for pen-touch by writing to page 3/register 3, bits D1–D0; choose either 0 or 2). In this mode, if touch is detected, then the TSC2117 generates the interrupt (if GPIO1 or GPIO2 is programmed) and then waits for the host to write to page 3/register 3, bits D5–D2. Once the host write is complete, the TSC2117 starts conversion for touch-screen coordinates based on the setting of page 3/register 3, bits D5–D2. After the time set by the interval timer, it checks for the touch again. If touch is still there, it starts conversion for touch-screen coordinates. However, if touch is removed, then it stops the conversion procedure. The next time touch is detected, the TSC2117 generates the interrupt (if GPIO1 or GPIO2 is programmed). Then it waits for the host to write page 3/register 3, bits D5–D2. This process continues.

Measuring touch pressure (Z) can also be done with the TSC2117. Generally, it is not necessary to have very high performance for this test; therefore, the 8-bit resolution mode is recommended (however, calculations are shown with the 12-bit resolution mode). There are several different ways of performing this measurement. The TSC2117 supports two methods. The first method requires knowing the X-plate resistance, measurement of the X-position, and two additional cross-panel measurements (Z_2 and Z_1) of the touch screen (see [Figure 5-38](#)). Using [Equation 8](#) calculates the touch resistance:

$$R_{\text{TOUCH}} = R_{\text{X-plate}} \times \frac{\text{X-position}}{4096} \left(\frac{Z_2}{Z_1} - 1 \right) \quad (8)$$

The second method requires knowing both the X-plate and Y-plate resistance, measurement of X-position and Y-position, and Z_1 . Using [Equation 9](#) also calculates the touch resistance:

$$R_{\text{TOUCH}} = \frac{R_{\text{X-plate}} \times \text{X-position}}{4096} \left(\frac{4096}{Z_1} - 1 \right) - R_{\text{Y-plate}} \times \left(1 - \frac{\text{Y-position}}{4096} \right) \quad (9)$$

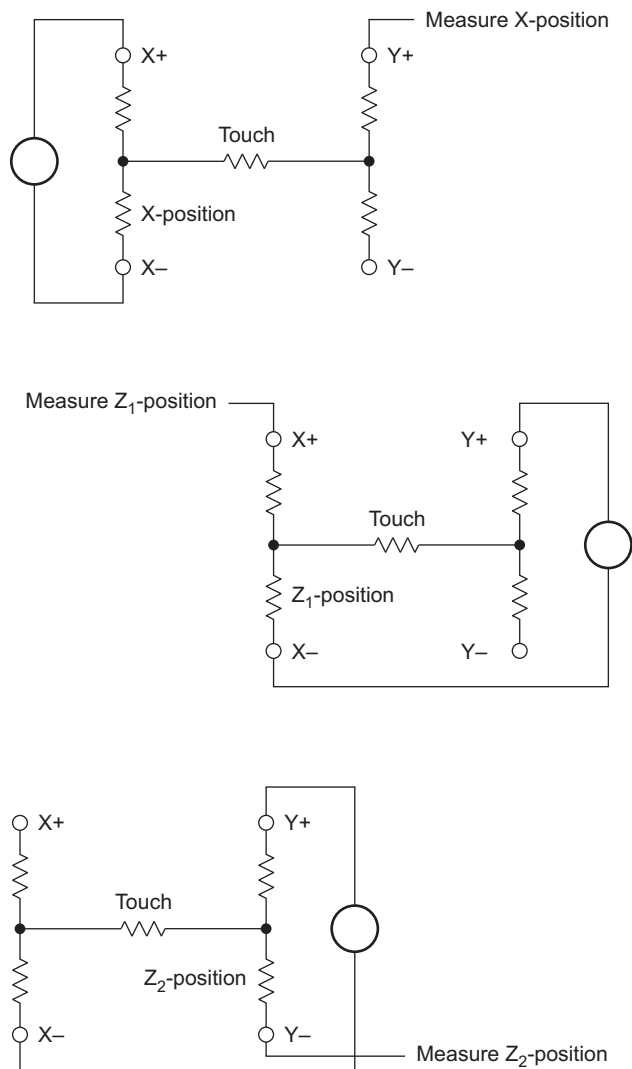

S0244-01

Figure 5-38. Pressure Measurement

5.7.1.1 Touch-Screen SAR ADC

The analog inputs of the TSC2117 are shown in [Figure 5-39](#). The analog inputs (X, Y, and Z touch-panel coordinates, battery-voltage monitors, chip temperature, and auxiliary inputs) are provided via a multiplexer to the successive approximation register (SAR) analog-to-digital converter (ADC). The ADC architecture is based on capacitive redistribution architecture, which inherently includes a sample/hold function.

A unique configuration of low on-resistance switches allows an unselected ADC input channel to provide power and an accompanying pin to provide ground for driving the touch screen. By maintaining a differential input to the converter and a differential reference input architecture, it is possible to negate errors caused by the driver-switch on-resistances.

The ADC is controlled by an ADC control register. Several modes of operation are possible, depending on the bits set in the control register. Channel selection, scan operation, resolution, and conversion rate may all be programmed through this register. These modes are outlined in the following sections for each type of analog input. The results of conversions made are stored in the appropriate result register.

The SAR ADC can be powered down forcefully by writing to page 3/register 2, bit D7. Overall SAR configuration and mode is controlled by writing to page 3/register 3, bits D7–D0.

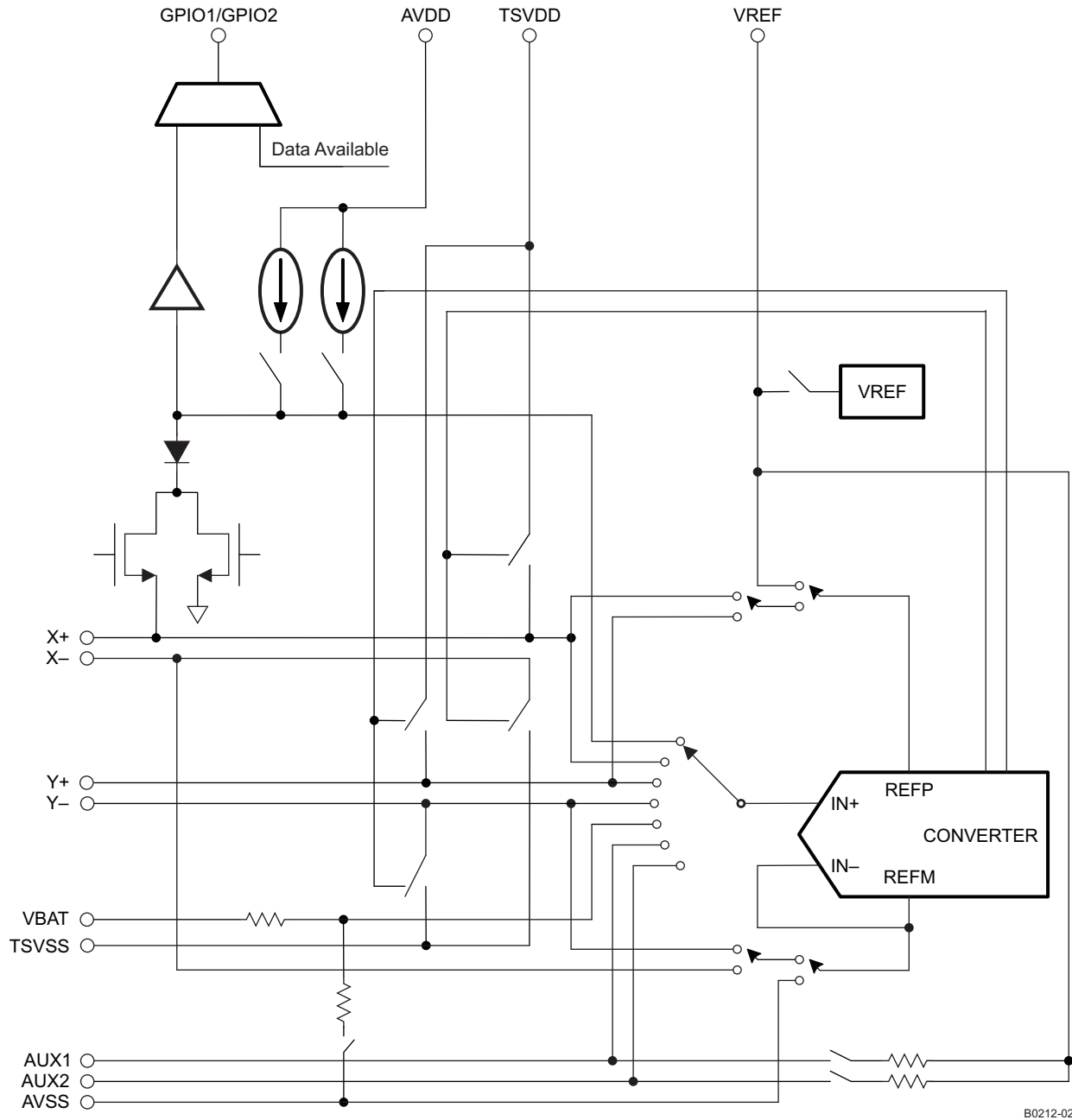

B0212-02

Figure 5-39. Simplified Diagram of the SAR ADC Analog Input Section

Data Format

The TSC2117 output data is in unsigned binary format and can be read from two 8-bit registers over the SPI interface.

Voltage Reference

The TSC2117 has an internal voltage reference that can be set to 1.25 V or 2.5 V through the reference control register (page 3/register 6) .

The internal reference voltage should only be used in the single-ended mode for battery monitoring, for temperature measurement, and for using the auxiliary inputs.

The TSC2117 is designed to allow use with an external voltage reference (page 3/register 6). In many systems, a 2.5-V reference is supplied; however, this device supports a reference voltage up to the AVDD level. The external reference should be a low-noise signal and accordingly, depending on the application, it might be good to provide some R-C filtering at the VREF pin.

This voltage reference should only be used in the single-ended mode for measuring the auxiliary inputs (AUX1, AUX2, and VBAT). Optimal touch-screen performance is achieved when using a ratiometric conversion; thus, all touch-screen measurements are done automatically in the ratiometric mode.

Variable Resolution

The TSC2117 provides three different resolutions for the ADC: 8, 10, or 12 bits. Lower resolutions are often practical for measurements such as system voltages. Performing the conversions at lower resolution reduces the amount of time it takes for the ADC to complete its conversion process, which lowers power consumption. The ADC resolution can be programmed by writing to page 3/register 2, bits D6–D5.

5.7.1.2 Conversion Clock and Conversion Time

The TSC2117 contains an internal oscillator, which is used to drive the state machines inside the device that perform the many functions of the part. MCLK is also available as a high-frequency clock source. The clock source (internal or MCLK) is selected by writing to page 3/register 16, bit D7. This clock is divided down to provide a clock to run the SAR ADC. The division ratio for this clock is set by writing to page 3/register 2, bits D4–D3. The ability to change the conversion clock rate allows the user to choose the optimal value for resolution, speed, and power. If the internal oscillator is used for the conversion clock, the ADC is limited to 8-bit resolution; using higher resolutions at this speed does not result in accurate conversions. Using a 4-MHz conversion clock is suitable for 10-bit resolution; 12-bit resolution requires that the conversion clock run at 1 or 2 MHz.

To avoid asynchronous issues, the system should use the same value for both page 3/register 16, bit 7 and page 3/register 17, bit 7.

Details for clock selection can be seen in [Figure 5-40](#).

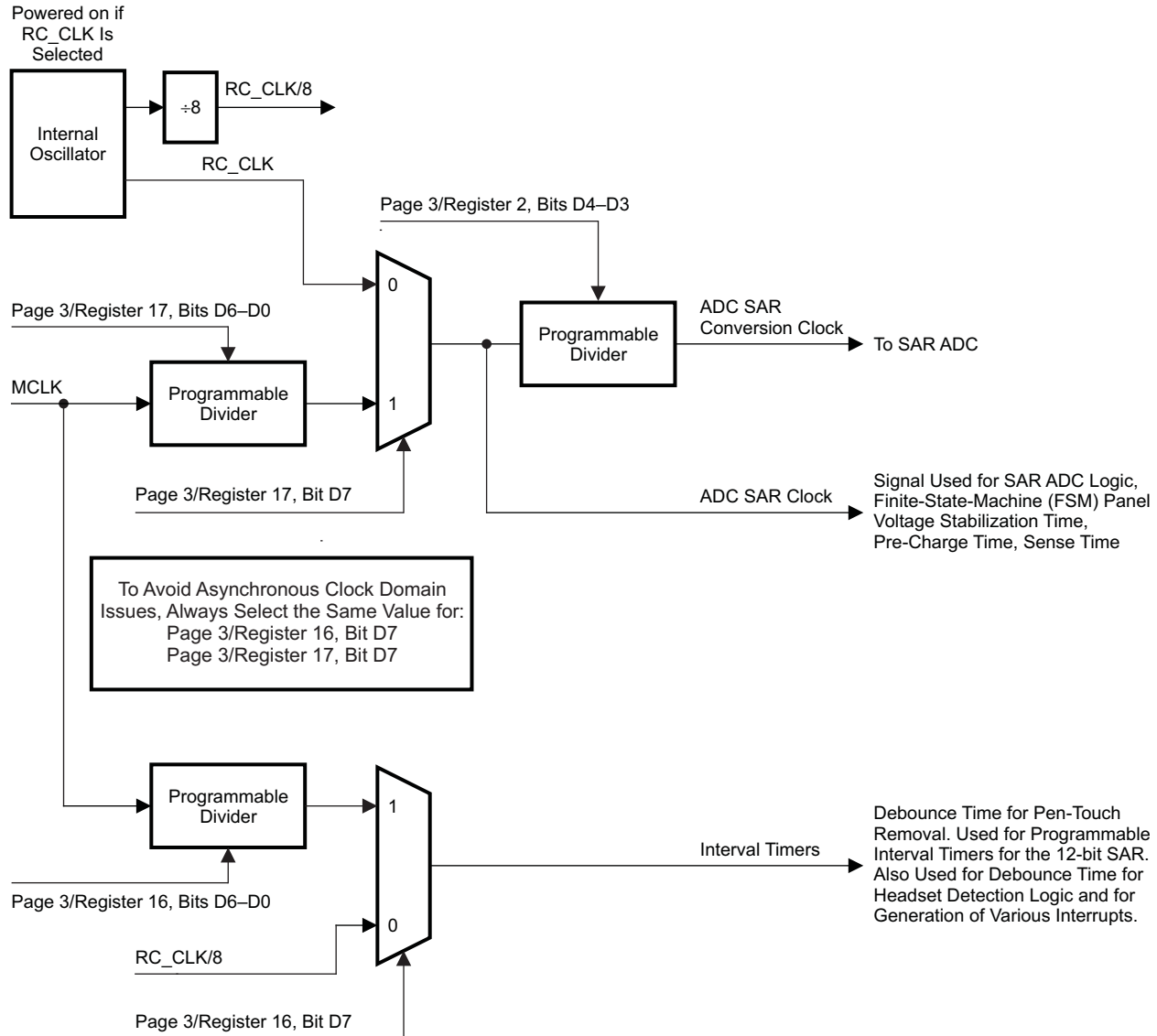

B0213-02

Figure 5-40. SAR ADC and Interval Timer Clock Selection

Regardless of the conversion clock speed, the internal clock runs nominally at 8.2 MHz. The conversion time of the TSC2117 depends on several functions. While the conversion clock speed plays an important role in the time it takes for a conversion to complete, a certain number of internal clock cycles are needed for proper sampling of the signal. Moreover, additional times, such as the panel voltage stabilization time, can add significantly to the time it takes to perform a conversion. Conversion time can vary, depending on the mode in which the TSC2117 is used. Throughout this data sheet, internal and conversion clock cycles are used to describe the times that many functions take to execute. Considering the total system design, these times must be taken into account by the user.

The ADC uses either the internal MCLK signal or the internal oscillator for the SAR conversions.

5.7.1.3 Touch Detect/Data Available – GPIO1 or GPIO2 Programmed as PINTDAV Signal

The interrupt pins (GPIO1 or GPIO2) can be programmed for three functions by writing to page 0/register 51, bits D5–D2 (GPIO1) or page 0/register 52, bits D5–D2 (GPIO2) the value of 1100. In this case, these pins function as the PINTDAV signal. The default setting of PINTDAV is for pen interrupt ($\overline{\text{PENIRQ}}$). However, it could be used for a data-available interrupt ($\overline{\text{DATA_AVA}}$), or it can be set up for signaling when either a pen interrupt occurs or the ADC data is available ($\overline{\text{PENIRQ}}$ and $\overline{\text{DATA_AVA}}$). To select which signal is used, page 3/register 3, bits D1–D0 must be programmed. A detailed block diagram is shown in Figure 5-41. While in the power-down mode, the Y– driver is ON and connected to TSVSS, and the X+ pin is connected through an on-chip pullup resistor to AVDD. In this mode, the X+ pin is also connected to a digital buffer and multiplexer to drive the GPIO1 or GPIO2 output. When the panel is touched, the X+ input is pulled to ground through the touch screen and the pen-interrupt signal goes LOW due to the current path through the touch-screen panel to TSVSS, initiating an interrupt to the processor. During the measurement cycles for X– and Y– position, the X+ input is disconnected from the pen-interrupt circuit to prevent any leakage current from the pullup resistor flowing through the touch screen, and thus causing conversion errors. The TSC2117 uses either the internal oscillator or MCLK for the debounce logic.

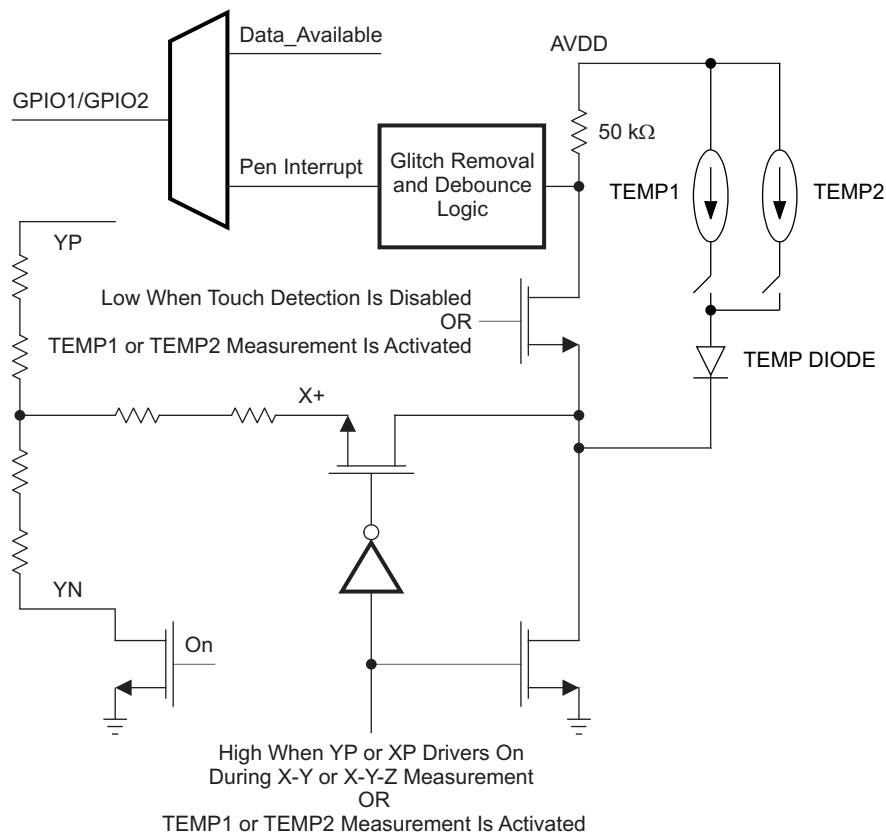

B0214-02

Figure 5-41. GPIO1/GPIO2 Functional Block Diagram

In modes where the TSC2117 must detect if the screen is still touched (for example, when doing a host-initiated X and Y conversion), the TSC2117 must reset the drivers so that the 50-kΩ resistor is connected. Because of the high value of this pullup resistor, any capacitance on the touch screen inputs causes a long delay time and may prevent the detection from occurring correctly. To prevent this, the TSC2117 has a circuit that allows any screen capacitance to be *precharged*, so that the pullup resistor is not the only

source for the charging current. The time allowed for this precharge, as well as the time needed for sensing and for voltage stabilization if the screen is still touched, can be controlled by register programming. Precharge time can be set by writing to page 3/register 4, bits D6–D4. Sense time can be set by writing to page 3, register 4, bits D2–D0, and voltage stabilization time can be set by writing to page 3/register 5, bits D2–D0.

The function of the GPIO1 or GPIO2 output is controlled by writing to page 3/register 3, bits D1–D0. The pen-touch detection circuit can be disabled by writing to page 3/register 4, bit D7.

5.7.2 Touch-Screen Measurements

The touch screen ADC either can be controlled by the host processor or can be self-controlled to offload processing from the host processor. Writing to page 3/register 3, bit D7 sets the control mode of the TSC2117 touch-screen ADC.

5.7.2.1 Conversion Controlled by the TSC2117 – Initiated by Touch Detect

This mode can be set by writing to page 3/register 3, bit D7 and page 3/register 4, bit D7. In this mode, the TSC2117 detects when the touch screen is touched and then causes the GPIO1 or GPIO2 line to go low. At the same time, the TSC2117 starts up its internal clock. Assuming the part was configured to convert XY coordinates, it then turns on the Y drivers, and after a programmed panel-voltage-stabilization time, powers up the ADC and converts the Y coordinate.

If the screen is still touched at this time, the X drivers are enabled and the process repeats, but measuring instead the X coordinate, storing the result in the X register.

If only X and Y coordinates are to be measured, then the conversion process is complete. If touch is still there, then the foregoing conversion process is repeated again and again until touch is removed or the SAR ADC is powered down. The time it takes to complete this process depends on the selected resolution, internal conversion clock rate, panel voltage stabilization time, and precharge and sense times. Precharge time can be set by writing to page 3/register 4, bits D6–D4. Sense time can be set by writing to page 3/register 4, bits D2–D0. Voltage stabilization time can be set by writing to page 3/register 5, bits D2–D0.

See *Conversion Time Calculation*, [Section 5.7.9](#), for timing diagrams and conversion-time calculations.

5.7.2.2 Conversion Controlled by the TSC2117 – Initiated by the Host

In this mode, the TSC2117 detects when the touch screen is touched and causes the GPIO1 or GPIO2 line to go low. The host recognizes the interrupt request, and then writes to the ADC control register (on page 3/register 3, bits D5–D2) to select one of the touch-screen scan functions. The host can either choose to initiate one of the scan functions, in which case the TSC2117 controls the driver turn-on and wait times (e.g., on receiving the interrupt, the host can initiate the continuous scan function (X-Y), after which the TSC2117 controls the rest of conversion).

See *Conversion Time Calculation*, [Section 5.7.9](#), for timing diagrams and conversion-time calculations.

5.7.3 Temperature Measurement

In some applications, such as battery charging, a measurement of ambient temperature is required. The temperature measurement technique used in the TSC2117 relies on the characteristics of a semiconductor junction operating at a fixed current level. The forward diode voltage (V_j) has a well-defined characteristic versus temperature. The ambient temperature can be predicted in applications by knowing the 25°C value of the V_j voltage and then monitoring the variation of that voltage as the temperature changes.

The TSC2117 offers two modes of temperature measurement. The first mode requires a single reading to predict the ambient temperature. A diode, as shown in [Figure 5-42](#), is used during this measurement cycle. This voltage is typically 600 mV at 25°C with a 20- μ A current through it. The absolute value of this diode voltage can vary a few millivolts. The temperature coefficient of this voltage is typically 2 mV/°C. During the final test of the end product, the diode voltage at a known room temperature is stored in nonvolatile memory. Further calibration can be done to calculate the precise temperature coefficient of the particular device. This method has a temperature resolution of approximately 0.4°C/LSB and accuracy of approximately $\pm 3^\circ\text{C}$ with two-temperature calibration. [Figure 5-43](#) and [Figure 5-44](#) show typical plots with single and two-temperature calibration, respectively.

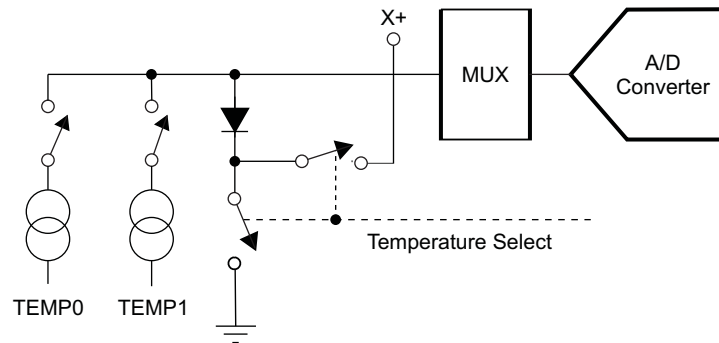

B0311-01

Figure 5-42. Functional Block Diagram of Temperature-Measurement Mode

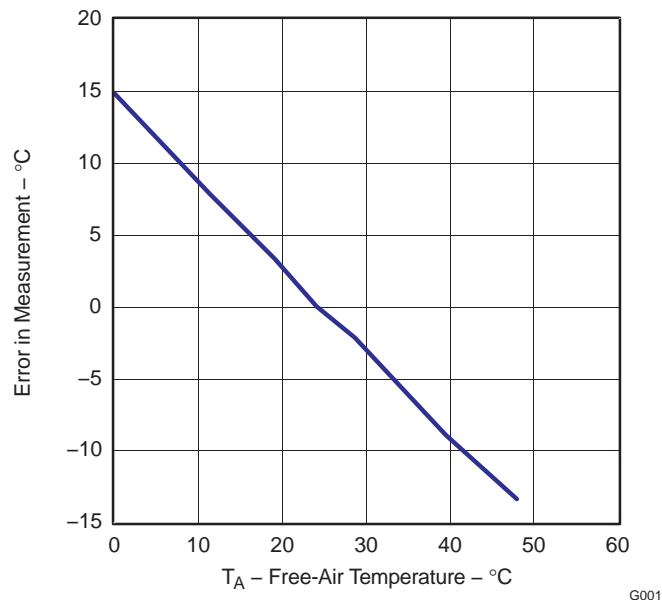

G001

Figure 5-43. Typical Plot of Single-Measurement Method After Calibrating for Offset at Room Temperature

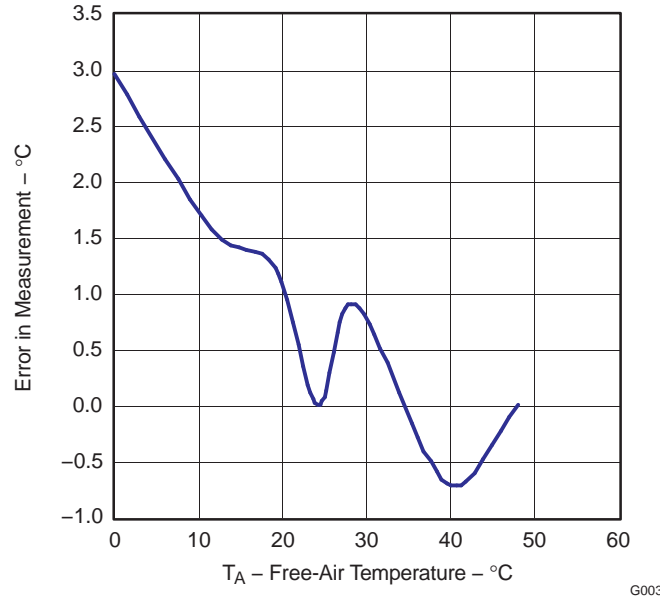

Figure 5-44. Typical Plot of Single-Measurement Method After Calibrating for Offset and Gain at Two Temperatures

The second mode uses a two-measurement (differential) method. This mode requires a second conversion with a current 82 times larger. The voltage difference between the first (TEMP1) and second (TEMP2) conversion, using 82 times the bias current, is represented by:

$$V_{(\text{Temp1} - \text{Temp2})} = \frac{kT}{q} \times \ln(N) \quad (10)$$

where

N is the current ratio = 82

k = Boltzmann's constant (1.38054×10^{-23} electrons volts/Kelvin)

q = the electron charge (1.602189×10^{-19} C)

T = the temperature in Kelvins

The equation for the relation between differential code and temperature may vary slightly from device to device and can be calibrated at final system test by the user. This method provides resolution of approximately 2°C/LSB and accuracy of approximately $\pm 6^\circ\text{C}$ after calibrating at room temperature. A plot of typical calibration error for this method is shown in [Figure 5-45](#).

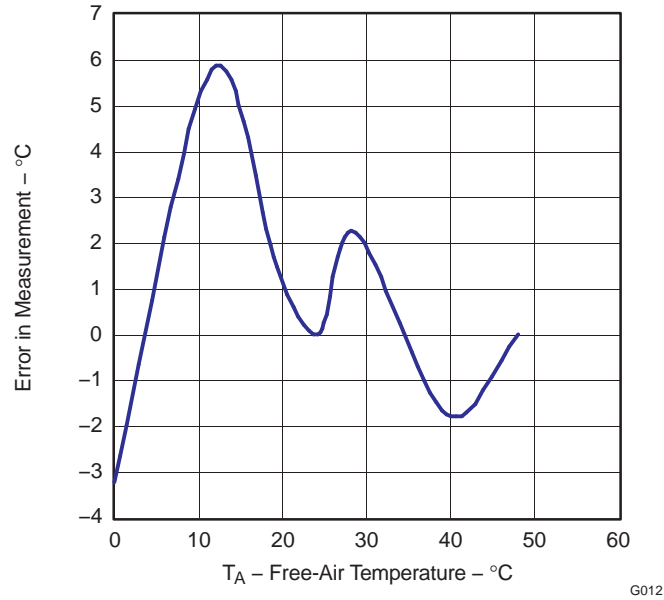

Figure 5-45. Typical Plot of Differential Measurement Method After Calibrating for Offset and Gain at Two Temperatures

The TSC2117 supports programmable auto-temperature measurement mode, which can be enabled using page 3/register 19. In this mode, the TSC2117 can auto-start the temperature measurement after a programmable interval. The user can program minimum and maximum threshold values through a register. If the measurement goes outside the threshold range, the TSC2117 sets a flag in read-only page 3/register 21, which is cleared after the flag is read. The TSC2117 can also be configured to send an active-high interrupt over GPIO1 or GPIO2 by setting page 0/register 50 and 52. The duration of the interrupt is approximately 2 ms.

Temperature measurement can only be done in host-controlled mode.

5.7.4 Auxiliary Voltage Measurements

The auxiliary voltage inputs (AUX1, AUX2, and VBAT) are measured using the single-ended measurement method with SAR ADC.

For AUX1 and AUX2:

If the conversion results in an ADC output code of B, then the voltage at the input pins (AUX1 and AUX2) can be calculated as:

$$V_{PIN} = \frac{B}{2^N} \times VREF \quad (11)$$

where:

N is the programmed resolution of the SAR ADC.

VREF is the applied external reference voltage.

For VBAT:

The VBAT pin can be used for two different functions:

5.7.4.1 Auxiliary Battery-Voltage Measurement for VBAT

The TSC2117 can be used to measure battery voltage up to 6 V. This measurement can be made using the VBAT pin, which has a voltage divider (divide by 5), as seen in [Figure 5-39](#). This analog prescaler is available on the pin to allow higher voltages to be measured by the SAR ADC. This battery measurement function is supported in 8-bit, 10-bit, and 12-bit modes.

To enable the battery-voltage measurement mode, write a 1 to page 3/register 6, bit D0.

Because the ADC code is 1/5 of the actual voltage value applied at VBAT, the correct value can be found by multiplying the ADC code by 5. For low voltages of VREF, this function can support voltages from 0 to (5 × VREF), where the upper voltage limit for VBAT is 6 V, and is also limited by the value listed in [Section 3.1](#), the *Absolute Maximum Ratings* table.

In the battery-voltage measurement mode, the conversion results in an ADC output code of B, where the voltage at the input pin (VBAT) can be calculated as:

$$V_{\text{BAT}} = \frac{B}{2^N} \times (5 \times V_{\text{REF}}) \quad (12)$$

where:

N is the programmed resolution of the SAR ADC.

VREF is the applied external reference voltage.

5.7.4.2 Auxiliary Input (Normal Mode) for VBAT

The default functionality for the VBAT input is similar to AUX1 and AUX2. The useful measurement range is 0 V to VREF, and the maximum voltage input should be limited to 3.6 V. Because VBAT has an internal resistor divider, the internal ADC code is scaled down; however, in the normal mode, it is internally scaled back up in the digital domain, so that the normal transfer function can be realized using the SAR ADC. Although this mode is supported in 8-bit, 10-bit, and 12-bit modes, the 8-bit mode does not show any missing codes, whereas the 10-bit and 12-bit mode can have one missing code due to the analog input scaling and digital output scaling. Therefore, it is recommended to always use 8-bit mode for VBAT.

$$V_{\text{BAT}} = \frac{B}{2^N} \times V_{\text{REF}} \quad (13)$$

where,

N is the programmed resolution of the SAR ADC.

VREF is the applied external reference voltage.

The auxiliary input can be monitored continuously in scan mode.

5.7.5 Port Scan

If making voltage measurements on the inputs AUX1, AUX2, and VBAT is desired on a periodic basis, then the port-scan mode can be used. This mode causes the TSC2117 to sample and convert each of the auxiliary inputs. At the end of this cycle, all of the auxiliary result registers contain the updated values. Thus, with one write to the TSC2117, the host can cause three different measurements to be made. Port scan can be set up by writing to page 3/register 3, bits D5–D2.

Port scan can only be used in host-controlled mode.

See *Conversion Time Calculations for the TSC2117*, [Section 5.7.9](#), and *Port-Scan Operation*, [Section 5.7.9.4](#), for conversion-time calculations and timing diagrams.

5.7.6 Buffer Mode

The TSC2117 supports a programmable buffer mode, which is applicable for both touch-screen-related conversion (X, Y, Z1, Z2) and nontouch-screen-related conversion (VBAT, AUX1, AUX2, TEMP1, TEMP2). Buffer mode is implemented using a circular FIFO with a depth of 64. The number of interrupts required to be serviced by a host processor can be reduced significantly buffer mode. Buffer mode can be enabled using page 3/register 13, bit D7.

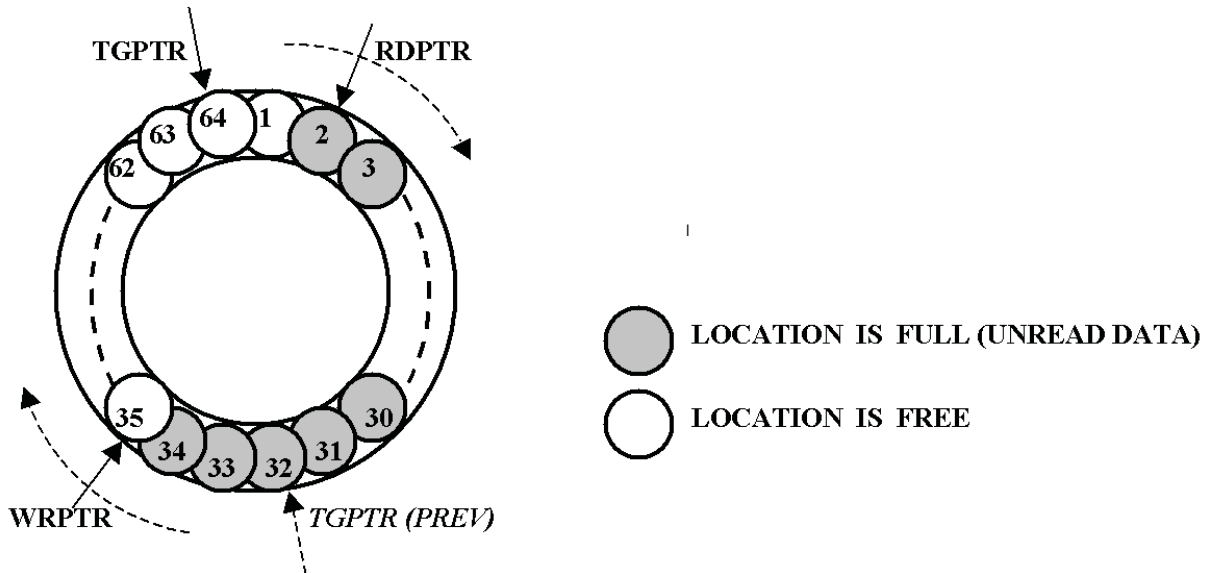

Figure 5-46. Circular Buffer

Converted data is automatically written into the FIFO. To control the writing, reading and interrupt process, a write pointer (WRPTR), a read pointer (RDPTR), and a trigger pointer (TGPTR) are used. The read pointer always shows the location that is read next. The write pointer indicates the location in which the next converted data is to be written. The trigger pointer indicates the location at which an interrupt is generated if the write pointer reaches that location. Trigger level is the number of the data values needed to be present in the FIFO before generating an interrupt. For example, in X-Y continuous-scan mode with trigger level set to 8, the TSC2117 generates an interrupt after writing (X1, Y1), (X2, Y2), (X3, Y3), (X4, Y4), i.e., four data-pairs or eight data values. [Figure 5-46](#) shows the case when the trigger level is programmed as 32. On resetting the buffer mode, RDPTR moves to location 1, WRPTR moves to location 1, and TGPTR moves to a location equal to the programmed trigger level.

The user can select the input or input sequence to be converted by writing to page 3/register 3, bits D5–D2. The converted values are written in a predefined sequence to the circular buffer. The user has flexibility to program a specific trigger level in order to choose the configuration which best fits the application. When the number of converted data values written in FIFO becomes equal to the programmed trigger level, then the device generates an interrupt signal on GPIO1 or GPIO2. In buffer mode, the user should program this pin as Data Available. In buffer mode, touch-screen-related conversions (X, Y, Z1, Z2) are allowed only in self-controlled mode and nontouch-screen-related conversions (VBAT, AUX1, AUX2, TEMP1, TEMP2) are allowed only in host-controlled mode.

Buffer mode can be used in single-shot conversion or continuous-conversion mode.

In single-shot conversion mode, once the number of data values written reaches the programmed trigger level, the TSC2117 generates an interrupt and waits for the user to start reading. As soon as the user starts reading the first data value from the last converted set, the TSC2117 clears the interrupt and starts a new set of conversions, and the trigger pointer is incremented by the programmed trigger level. An interrupt is generated again when the trigger condition is satisfied.

In continuous-conversion mode, once the number of data values written reaches the programmed trigger level, the TSC2117 generates an interrupt. It immediately starts a new set of conversions, and the trigger pointer is incremented by the programmed trigger level. An interrupt is cleared either by writing the next converted data value into the FIFO or by starting to read from the FIFO.

Depending on how the user is reading data, the FIFO can become empty or full. If the user is trying to read data even if the FIFO is empty, then RDPTR keeps pointing to same location. If the FIFO becomes full, then the next location is overwritten with newly converted data values, and the read pointer is incremented by one.

While reading the FIFO, the TSC2117 provides FIFO-empty and -full status flags along with the data. The user can also read a status flag from page 3/register 13, bits D1–D0. See [Table 5-39](#) for buffer-mode control and [Table 5-40](#) for buffer-mode 16-bit read-data format.

Table 5-39. Buffer Mode Control (Page 3/Register 18, Bits D7–D5)⁽¹⁾

BIT	READ/ WRITE	RESET VALUE	DESCRIPTION
D7	R/W	0	0: SPI interface is used for buffer data reading. 1: I ² C interface is used for buffer data reading.
D6	R/W	0	0: SAR/buffer data update is automatically halted (to avoid simultaneous buffer read and write operations) based on internal detection logic. 1: SAR/buffer data update is held using software control (page 3/register 18, bit D5).
D5	R/W	0	0: SAR/buffer data update is enabled all the time (valid only if page 3/register 18, bit D6 = 1). 1: SAR/buffer data update is stopped so that user can read the last updated data without any data corruption. (Valid only if page 3/register 18, bit D6 = 1).

(1) To enable buffer mode, write a 1 to page 3/register 13, bit D7.

Table 5-40. Buffer Mode 16-Bit Read Data Format (Page 252/Registers 1 and 2)

BUFFER READ DATA BIT	NAME	RESET VALUE	DESCRIPTION	COMMENT
D15	FUF	0	Buffer-full flag – This flag indicates that all the 64 locations of the buffer contain unread data.	Page 252/register 1, bit D7
D14	EMF	1	Buffer Empty Flag - This flag indicates that there is no unread data available in FIFO. This is generated while reading the last converted data.	Page 252/register 1, bit D6
D13		X	Reserved	Page 252/register 1, bit D5
D12	ID	X	Data identification: 0 = X or Z1 coordinate or BAT or AUX2 data in R11–R0 1 = Y or Z2 coordinate or AUX1 or TEMP data in R11–R0 Order for writing data in buffer when multiple inputs are selected: For XY conversion: Y, X For XYZ1Z2 conversion: Y, X, Z1, Z2 For Z1Z2 conversion: Z1, Z2 For autoscan conversion: AUX1 (if selected), AUX2 (if selected), TEMP (if selected) For port-scan conversion: BAT, AUX1, AUX2	Page 252/register 1, bit D4
D11–D8	R11–R8	X	Converted data (MSB, 4 bits)	Page 252/register 1, bits D3–D0
D7–D0	R7–R0	X	Converted data (LSB, 8 bits)	Page 252/register 2, bits D7–D0

5.7.7 Reading X-Y Data in Non-Buffer Mode From SPI

Reading from the TSC2117 is done by using the protocol called out in [Figure 5-47](#). This protocol uses a 24-clock sequence to get a 16-bit data read. Set the GPIO1 or GPIO2 interrupt for monitoring the data-available status by writing to page 3/register 3, bits D1 and D0. Reading is normally done when the interrupt is low (data is available for reading). Status from the ADC conversion can be read from page 3/register 9. If bit D6 is set, then the ADC is actively converting, so a BUSY status is read. If bit D5 is set, then some data is now available for reading. If bit D3 is set, then the X-coordinate data can be read, and if bit D2 is set, then the Y-coordinate data can be read.

The first 7 bits in the read sequence are for the first register address of the two sequential 8-bit registers. The next bit is high, which specifies that a read operation follows, then the 16 remaining clocks are used to get the 16-bit data that is read out in the order of D15–D0. The register address specified in the first seven clocks of the 24-clock sequence is read out as bits D15–D8, where D15 is the MSB of the byte; then the register number is incremented by 1 and the data is read from D7–D0, where D7 is the MSB of that byte. (For reading an X-coordinate, use address 42, and for reading a Y-coordinate, use address 44.) From this cycle, the first 16-bit data word has been read. This sequence can be repeated to read further values of X-coordinates and Y-coordinates.

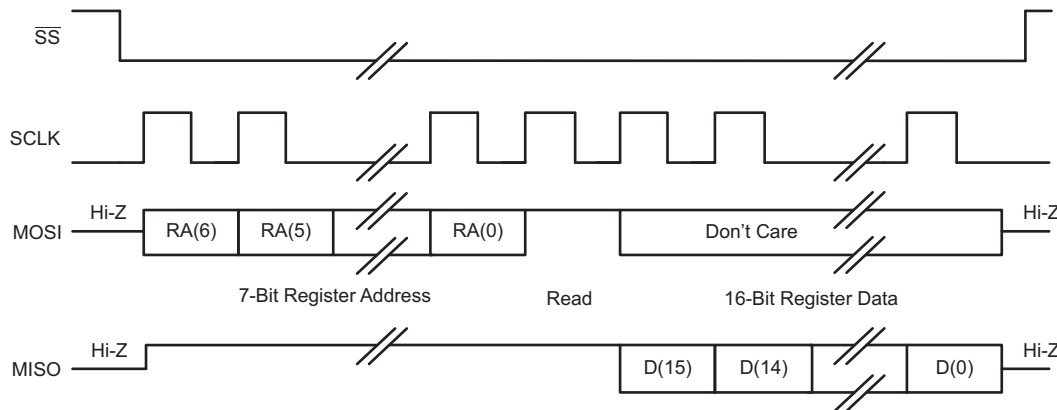

Figure 5-47. 16-Bit Data-Read Timing, 24 Clocks per 16-Bit Data Read, 8-Bit Bus Interface

5.7.8 Reading AUX Data in Non-Buffer Mode From SPI

Reading from the TSC2117 is done by using the protocol called out in [Figure 5-47](#). This protocol uses a 24-clock sequence to get a 16-bit data read. Set the GPIO1 or GPIO2 interrupt for monitoring the data-available status by writing to page 3/register 3, bits D1 and D0. Reading is normally done when the interrupt is low (data is available for reading). Status from the ADC conversion can be read from page 3/register 9. If bit D6 is set, then the ADC is actively converting, so a BUSY status is read. If bit D5 is set, then some data is now available for reading. Next, reading from a status register on page 3/register 10 lets us know if data is available for AUX1, AUX2, or VBAT. If bit D7 is set, then AUX1 data can be read. If bit D6 is set, then AUX2 data can be read. If bit D5 is set, then VBAT data can be read.

The first 7 bits in the read sequence are for the first register address of the two sequential 8-bit registers. The next bit is high, which specifies that a read operation follows; then the 16 remaining clocks are used to get the 16-bit data that is read out in the order of D15–D0. The register address specified in the first seven clocks of the 24-clock sequence reads out as bits D15–D8, where D15 is the MSB of the byte, then the register number is incremented by 1 and the data is read from D7–D0, where D7 is the MSB of that byte. (For reading data for AUX1, use page 3/register 54; for reading data for AUX2, use page 3/register 56; and for reading data for VBAT, use page 3/register 58.) From this cycle, the first 16-bit data word has been read. This sequence can be repeated to read further values of AUX1, AUX2, and VBAT data.

5.7.9 Conversion Time Calculations for the TSC2117

This section discusses three conversion time calculations for TSC2117:

1. Touch-screen conversion initiated at touch detect
2. Touch-screen conversion initiated by the host
3. Non-touch-screen measurement operation – temperature, auxiliary, or battery measurements

In all three cases, the timing signals can be programmed by page 3/register 3. GPIO1 or GPIO2 can be programmed as `PINTDAV` (page 3/register 3, bits D1–D0) which is used to signal a pen touch detected and/or data available.

5.7.9.1 Touch-Screen Conversion Initiated at Touch Detect

5.7.9.1.1 Self-Controlled X-Y Scan Mode

The time needed to get a converted X/Y coordinate for reading (not including the time needed to send the command over the SPI bus) can be calculated by:

$$t_{\text{coordinate}} = 2 \times (t_{\text{PRE}} + t_{\text{SNS}} + t_{\text{PVS}}) + 2 \times N_{\text{AVG}} \times (N_{\text{BITS}} + 1) \times t_{\text{CONV}} + 2 \times N_{\text{AVG}} \times (n_1 + 13) \times t_{\text{CLK}} + 22 \times t_{\text{CLK}} + t_{\text{DEL}}$$

- (1) This formula is valid only if page 2/register 18, bits D6–D5 = 00, which means SAR data update is not kept on hold for reading converted data.
- (2) After touch detect, the formula holds true from the second conversion onwards.
- (3) All the programmable delay t_{DEL} , t_{PVS} , t_{SNS} and t_{PRE} scale accordingly based on the actual divider setting and time period of the clock used to generate this. See the respective control register settings to understand the scale factors.
- (4) If page 3/register 3, bits D1–D0 = 00, then in case of continuous touch, $\overline{\text{PINTDAV}}$ as shown in Figure 5-48 remains high for approximately t_{PRE} . If page 3/register 3, bits D1–D0 = 10, then in case of continuous touch, $\overline{\text{PINTDAV}}$ remains high for approximately $(t_{\text{PRE}} + t_{\text{DEL}})$.

where:

$t_{\text{CLK}} = t_{\text{OSC}}$ or $t_{\text{MCLK}} \times \text{DIV3}$ (based on page 3/register 17, bit D7 setting)

$t_{\text{CONV}} = t_{\text{CLK}} \times \text{DIV1}$

DIV1 = Divider setting configured in page 3/register 2, bits D4–D3

DIV3 = Divider setting configured in page 3/register 17, bits D6–D0

N_{BITS} = SAR ADC resolution set in page 3/register 2, bits D6–D5

N_{AVG} = Number of averages selected using page 3/register 2, bits D1–D0. For no averaging, $N_{\text{AVG}} = 1$.

t_{OSC} = Clock period of on-chip oscillator, typical value is 122 ns (i.e., 8.2 MHz)

t_{MCLK} = External MCLK clock period

$n_1 = 6$ if DIV1 = 1; otherwise, $n_1 = 7$

t_{DEL} = Delay time setting as configured in page 3/register 15, bits D6–D4; it is 0 if page 3/register 15, bit D7 = 0.

t_{PVS} = Panel-voltage stabilization time as set in page 3/register 5, bits D2–D0

t_{SNS} = Sense time as set in page 3/register 4, bits D2–D0

t_{PRE} = Precharge time as set in page 3/register 4, bits D6–D4

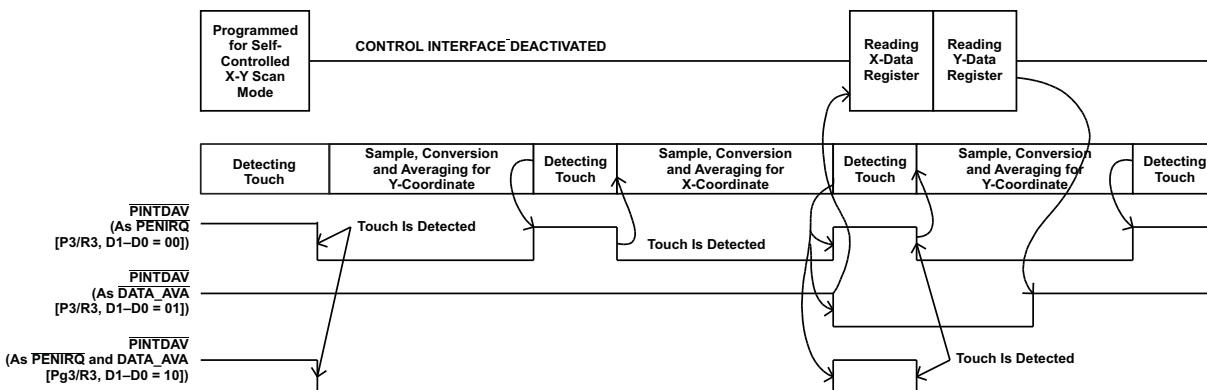

Figure 5-48. TSC2117 Self-Controlled X-Y Scan Mode

5.7.9.1.2 Self-Controlled X-Y-Z1-Z2 Scan Mode

The time for a complete X/Y/Z1/Z2 coordinate conversion (not including the time needed to send the command over the SPI bus) is given by:

$$t_{\text{coordinate}} = 3 \times (t_{\text{PRE}} + t_{\text{SNS}} + t_{\text{PVS}}) + 4 \times N_{\text{AVG}} \times (N_{\text{BITS}} + 1) \times t_{\text{CONV}} + 4 \times N_{\text{AVG}} \times (n_1 + 13) \times t_{\text{CLK}} + 40 \times t_{\text{CLK}} + t_{\text{DEL}}$$

where:

$$n1 = 6 \text{ if } DIV1 = 1; \text{ otherwise, } n1 = 7$$

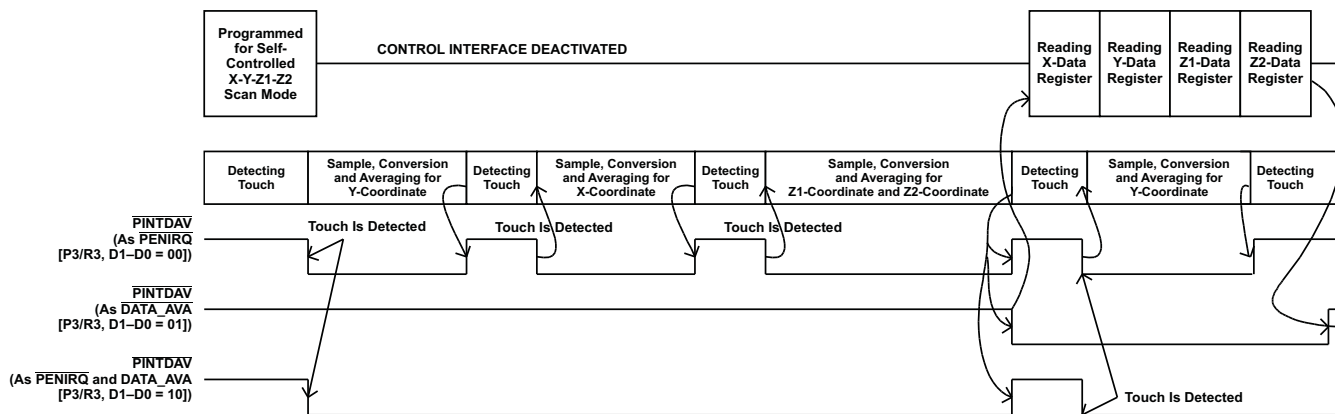

Figure 5-49. TSC2117 Self-Controlled X-Y-Z1-Z2 Scan Mode

5.7.9.1.3 Self-Controlled X-Scan or Y-Scan Mode

The time needed to convert any single coordinate, either X or Y, (not including the time needed to send the command over the SPI bus) under self-controlled mode is given by:

$$t_{\text{coordinate}} = t_{\text{PRE}} + t_{\text{SNS}} + t_{\text{PVS}} + N_{\text{AVG}} \times (N_{\text{BITS}} + 1) \times t_{\text{CONV}} + N_{\text{AVG}} \times (n1 + 13) \times t_{\text{CLK}} + 18 \times t_{\text{CLK}} + t_{\text{DEL}}$$

where:

$$n1 = 6 \text{ if } DIV1 = 1; \text{ otherwise, } n1 = 7$$

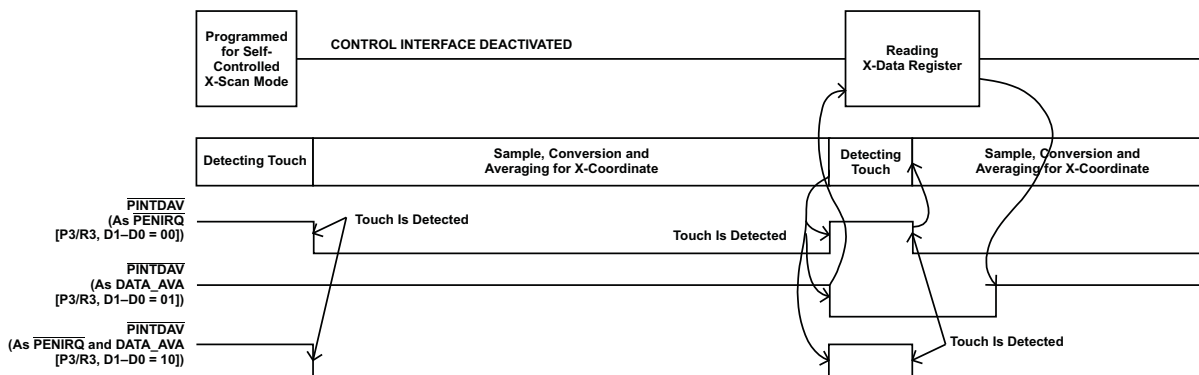

Figure 5-50. TSC2117 Self-Controlled X-Scan Mode

5.7.9.1.4 Self-Controlled Z-Scan Mode

The time needed to convert the Z coordinate under self-controlled mode (not including the time needed to send the command over the SPI bus) is given by:

$$t_{\text{coordinate}} = t_{\text{PRE}} + t_{\text{SNS}} + t_{\text{PVS}} + 2 \times N_{\text{AVG}} \times (N_{\text{BITS}} + 1) \times t_{\text{CONV}} + 2 \times N_{\text{AVG}} \times (n1 + 13) \times t_{\text{CLK}} + 25 \times t_{\text{CLK}} + t_{\text{DEL}}$$

where:

$$n1 = 6 \text{ if } DIV1 = 1; \text{ otherwise, } n1 = 7$$

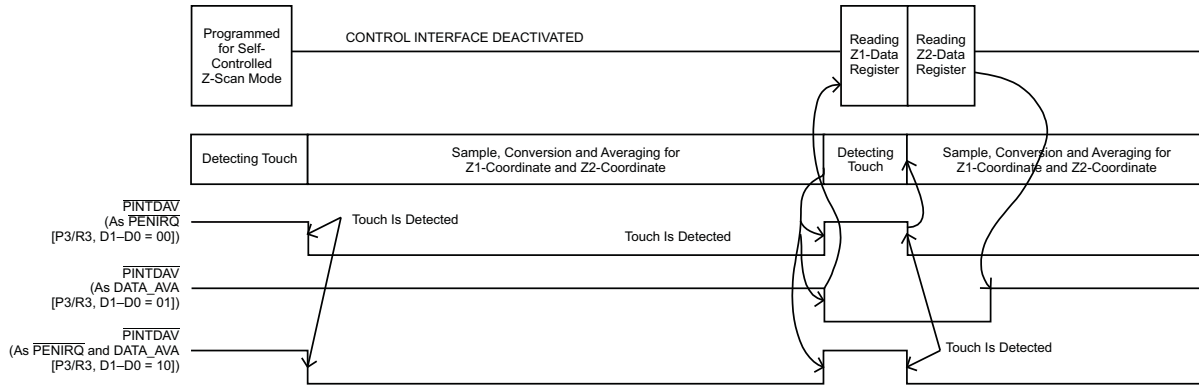

Figure 5-51. TSC2117 Self-Controlled Z-Scan Mode

5.7.9.2 Touch-Screen Conversion Initiated by the Host

5.7.9.2.1 Host-Controlled X-Scan Mode

The time needed to convert any single coordinate, either X or Y, under host-controlled mode (not including the time needed to send the command over the SPI bus) is given by:

$$t_{\text{coordinate}} = t_{\text{PVS}} + N_{\text{AVG}} \times (N_{\text{BITS}} + 1) \times t_{\text{CONV}} + N_{\text{AVG}} \times (n_1 + 13) \times t_{\text{CLK}} + 15 \times t_{\text{CLK}}$$

where:

$$n_1 = 6 \text{ if } \text{DIV1} = 1; \text{ otherwise, } n_1 = 7$$

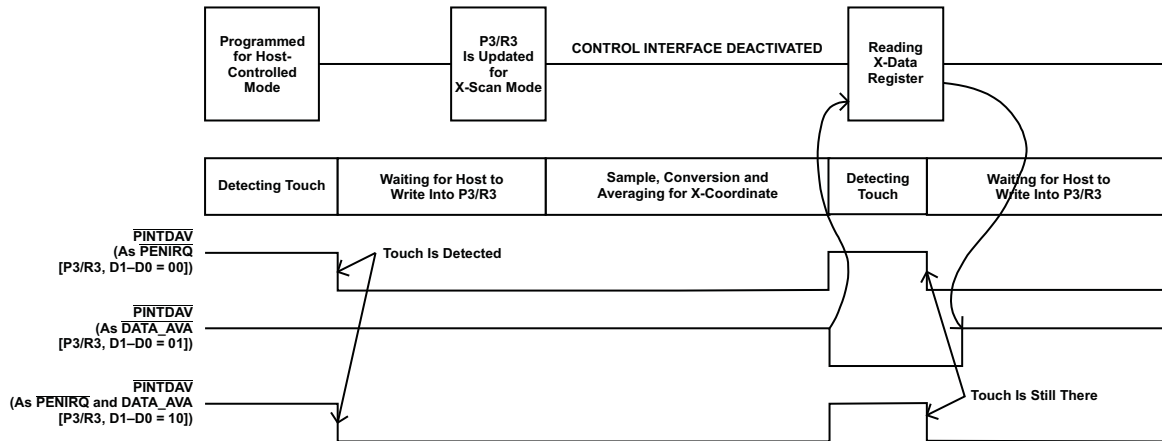

Figure 5-52. Host-Controlled X-Scan Mode

5.7.9.2.2 Host-Controlled Z1-Z2 Scan Mode

$$t_{\text{coordinate}} = t_{\text{PVS}} + 2 \times N_{\text{AVG}} \times (N_{\text{BITS}} + 1) \times t_{\text{CONV}} + 2 \times N_{\text{AVG}} \times (n_1 + 13) \times t_{\text{CLK}} + 22 \times t_{\text{CLK}}$$

where:

$$n_1 = 6 \text{ if } \text{DIV1} = 1; \text{ otherwise, } n_1 = 7$$

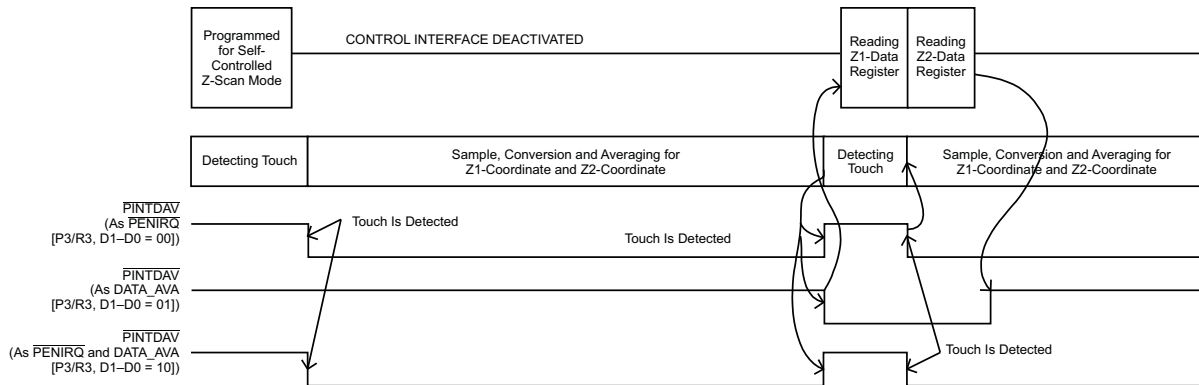

Figure 5-53. Host-Controlled Z1-Z2 Scan Mode

5.7.9.2.3 Host-Controlled X-Y Scan Mode

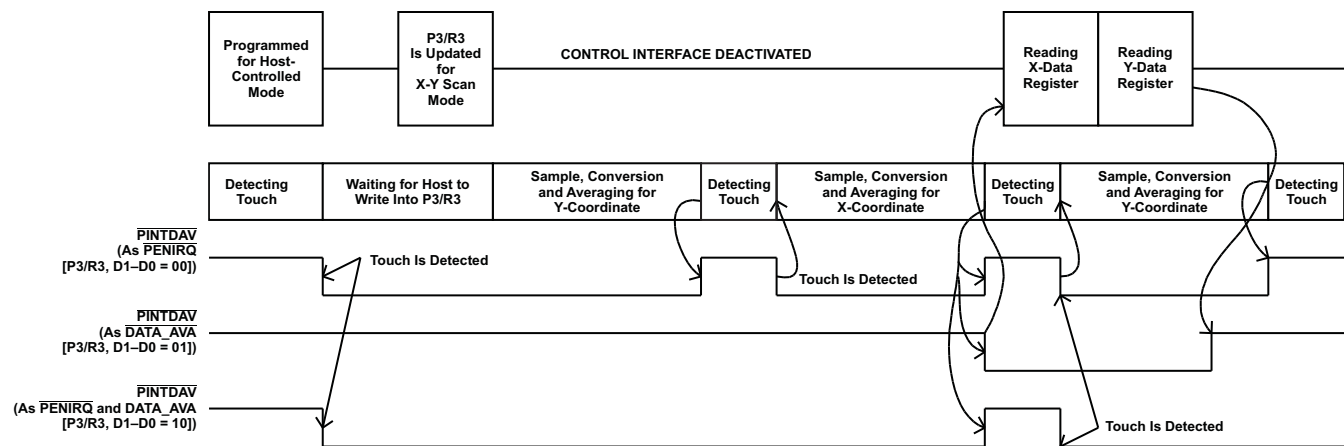

Figure 5-54. Host-Controlled X-Y Scan Mode

5.7.9.3 Non-Touch-Screen Measurement Operation

5.7.9.3.1 Host-Controlled VBAT Scan Mode

The time needed to make temperature, auxiliary, or battery measurements is given by:

$$t = N_{AVG} \times (N_{BITS} + 1) \times t_{CONV} + N_{AVG} \times (n_1 + n_2) \times t_{CLK} + 17 \times t_{CLK} + n_3 \times t_{CLK}$$

- (1) This equation is valid if page 2/register 18, bits D6–D5 = 00, which means SAR data update is not kept on hold for reading converted data.
- (2) The programmable delay t_{REF} scales accordingly based on the actual divider setting and time period of the clock used to generate this. See the respective control register settings to understand the scale factors.

where:

DIV1 = Divider setting configured in page 3/register 2, bits D4–D3; or 4 if VBAT is used as the normal AUX input by setting page 3/register 6, bit D0 = 0

NBITS = SAR ADC resolution configured in page 3/register 2, bits D6–D5; or 12 if VBAT is used as normal aux input by setting page 3/register 6, bit D0 = 0

$n_1 = 6$ if DIV1 = 1; otherwise, $n_1 = 7$

$n_2 = 24$ if measurement is for TEMP1; or 13 if measurement is other than TEMP1; or 400 if measurement is for the external/internal resistance using page 3/register 19, bits D2–D1 for AUX1/AUX2

$n_3 = 0$ if external reference mode is selected; or 3 if $t_{REF} = 0$ ms or internal reference is powered up all the time; or $1 + t_{REF}/t_{CLK}$ if t_{REF} is not equal to 0 ms and internal reference must power down between conversions

t_{REF} = Internal reference stabilization time as configured in page 3/register 6, bits D3–D2.

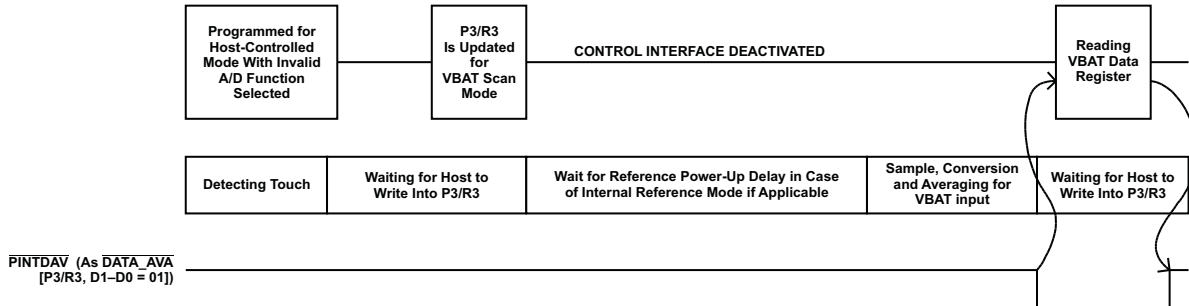

Figure 5-55. Host-Controlled BAT1 Scan Mode

5.7.9.3.2 Host-Controlled Continuous Aux Scan Mode

The time needed for continuous autoscan mode is given by:

$$t = N_{INP} \times N_{AVG} \times (N_{BITS} + 1) \times t_{CONV} + N_{INP} \times N_{AVG} \times (n_1 + 13) \times t_{CLK} + N_{AVG} \times n_2 \times t_{CLK} + N_{INP} \times 9 \times t_{CLK} + (n_3 + n_4) \times t_{CLK} + t_{DEL}$$

- (1) This equation is valid if page 2/register 18, bits D6–D5 = 00, which means SAR data update is not kept on hold for reading converted data.
- (2) This equation is valid only from the second conversion onward.
- (3) If one of the inputs enabled for autoscan is VBAT, then this equation is valid if page 3/register 6, bit D0 = 1.
- (4) All the programmable delays, t_{DEL} and t_{REF} , scale accordingly based on the actual divider setting and time period of the clock used to generate this. See the respective control register settings to understand the scale factors.

where:

DIV1 = Divider setting configured in page 3/register 2, bits D4–D3

N_{BITS} = SAR ADC resolution configured in page 3/register 2, bits D6–D5

N_{INP} = 1 to 4, based on the number of inputs enabled for autoscan by using page 3/register 19

$n_1 = 6$ if DIV1 = 1; otherwise, $n_1 = 7$

$n_2 = 11$ if one of the inputs selected is TEMP1; otherwise, $n_2 = 0$

$n_3 = 0$ if external reference mode is selected or

$t_{DEL} = 0$; or 3 if $t_{REF} = 0$ ms or internal reference is powered up all the time; or $1 + t_{REF}/t_{CLK}$ if

t_{REF} is not equal to 0 ms and internal reference must power down between conversions.

$n_4 = 0$ if $t_{DEL} = 0$; otherwise, $n_4 = 7$

t_{DEL} = Delay-time setting as configured in page 3/register 15, bits D2–D0; or 0 if page 3/register 15, bit D3 = 0

t_{REF} = Internal reference stabilization time as configured in page 3/register 6, bits D3–D2.

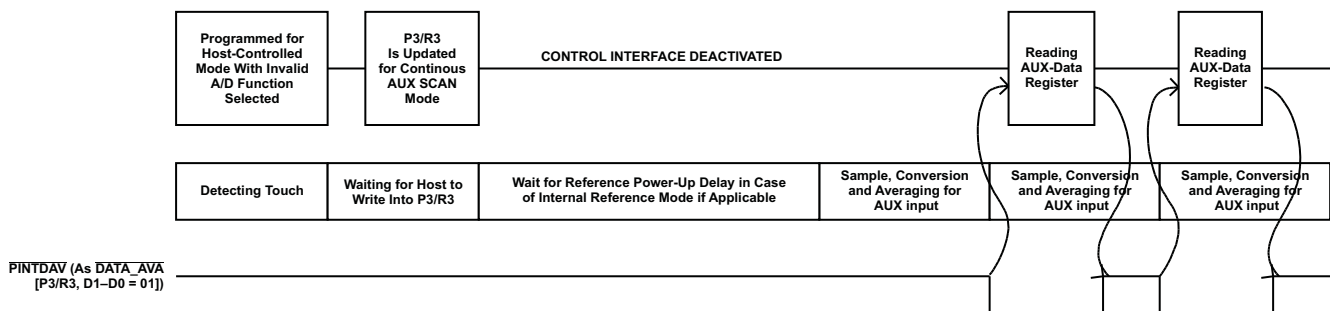

Figure 5-56. Host-Controlled Continuous Aux Scan Mode

5.7.9.4 Port-Scan Operation

The time needed to complete one set of port-scan conversions is given by:

$$t = 3 \times N_{AVG} \times (N_{BITS} + 1) \times t_{CONV} + 3 \times N_{AVG} \times (n_1 + 13) \times t_{CLK} + 35 \times t_{CLK} + n_2 \times t_{CLK}$$

- (1) This equation is valid if page 2/register 18, bits D6–D5 = 00, which means SAR data update is not kept on hold for reading converted data.
- (2) This equation is valid if page 3/register 6, bit D0 = 1.
- (3) The programmable delay t_{REF} scales accordingly based on the actual divider setting and time period of the clock used to generate this. See the respective control register settings to understand the scale factors.

where:

DIV1 = Divider setting as configured in page 3/register 2, bits D4–D3

N_{BITS} = SAR ADC resolution as configured in page 3/register 2, bits D6–D5

$n_1 = 6$ if DIV1 = 1; otherwise, $n_1 = 7$

$n_2 = 0$ if external reference mode is selected; or 3 if $t_{REF} = 0$ ms or internal reference is powered up all the time; or $1 + t_{REF}/t_{CLK}$ if t_{REF} is not equal to 0 ms and internal reference must power down between conversions

t_{REF} = Internal reference stabilization time as configured in page 3/register 6, bits D3–D2.

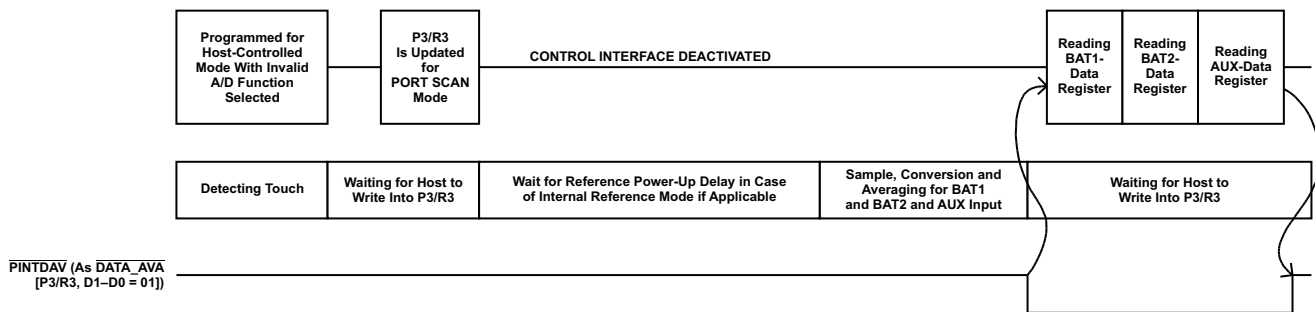
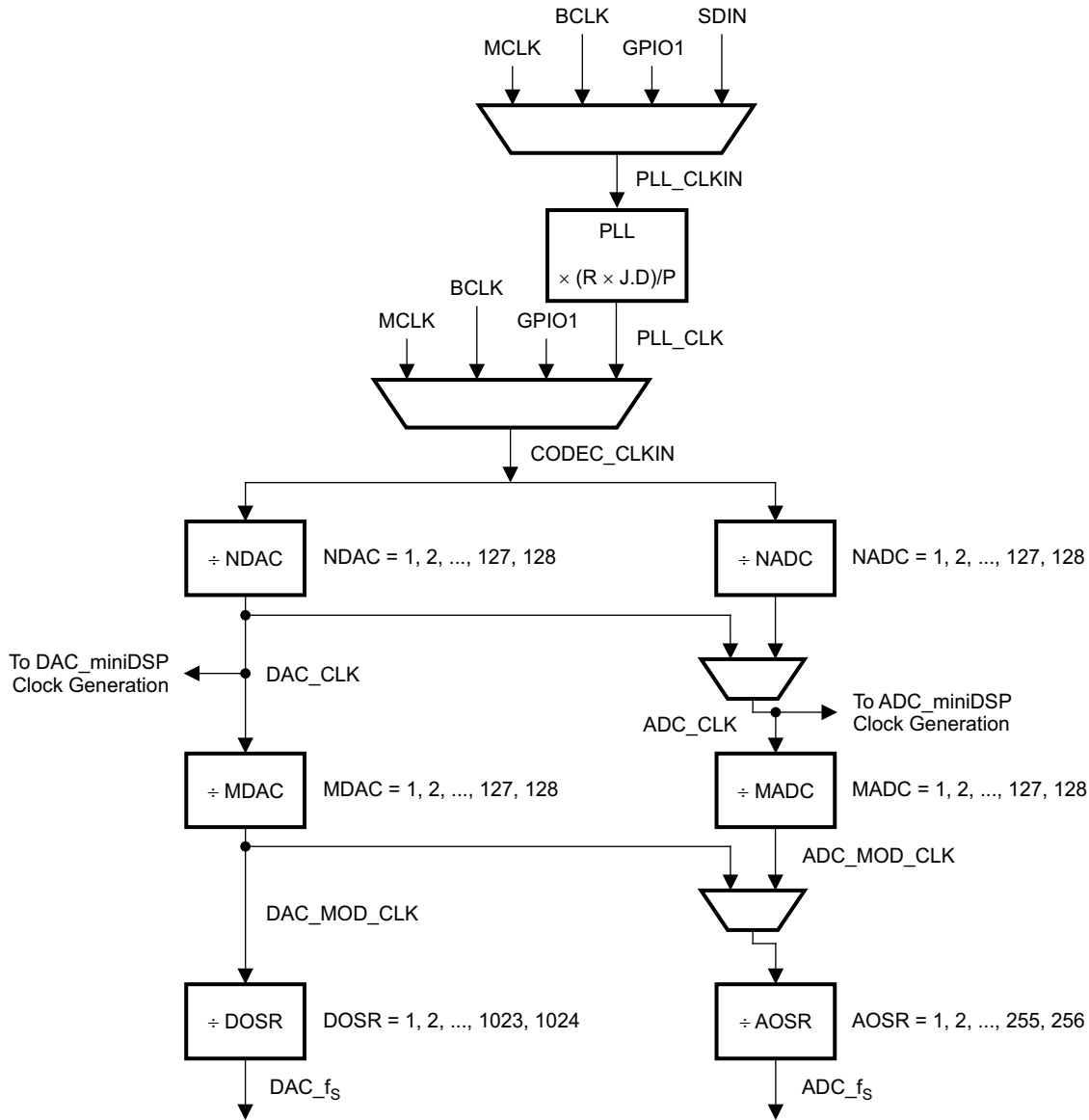

Figure 5-57. Host-Controlled Port Scan Mode

5.8 CLOCK Generation and PLL

The TSC2117 supports a wide range of options for generating clocks for the ADC and DAC sections as well as interface and other control blocks as shown in [Figure 5-58](#). The clocks for ADC and DAC require a source reference clock. This clock can be provided on variety of device pins such as MCLK, BCLK, or GPIO1 pins. The source reference clock for the codec can be chosen by programming the CODEC_CLKIN value on page 0/register 4, D(1:0). The CODEC_CLKIN can then be routed through highly-flexible clock dividers shown in [Figure 5-58](#) to generate the various clocks required for ADC, DAC and the miniDSP sections. In the event that the desired audio or miniDSP clocks cannot be generated from the reference clocks on MCLK, BCLK, or GPIO1, the TSC2117 also provides the option of using the on-chip PLL which supports a wide range of fractional multiplication values to generate the required clocks. Starting from CODEC_CLKIN the TSC2117 provides several programmable clock dividers to help achieve a variety of sampling rates for ADC, DAC and clocks for the miniDSP.



B0357-01

Figure 5-58. Clock Distribution Tree

$$DAC_MOD_CLK = \frac{CODEC_CLKIN}{NDAC \times MDAC}$$

$$ADC_MOD_CLK = \frac{CODEC_CLKIN}{NADC \times MADC}$$

$$DAC_f_s = \frac{CODEC_CLKIN}{NDAC \times MDAC \times DOSR}$$

$$ADC_f_s = \frac{CODEC_CLKIN}{NADC \times MADC \times AOSR}$$

(14)

Table 5-41. CODEC CLKIN Clock Dividers

Divider	Bits
NDAC	page 0/register 11, D(6:0)
MDAC	page 0/register 12, D(6:0)
DOSR	page 0/register 13, D(1:0) + page 0/register 14, D(7:0)

Table 5-41. CODEC CLKIN Clock Dividers (continued)

Divider	Bits
NADC	page 0/register 18, D(6:0)
MADC	page 0/register 19, D(6:0)
AOSR	page 0/register 20, D(7:0)

The DAC Modulator is clocked by DAC_MOD_CLK. For proper power-up operation of the DAC Channel, these clocks must be enabled by configuring the NDAC and MDAC clock dividers (page 0/register 11, bit D7 =1 and page 0/register 12, bit D7=1). When the DAC channel is powered down, the device internally initiates a power-down sequence for proper shut-down. During this shut-down sequence, the NDAC and MDAC dividers must not be powered down, or else a proper low power shut-down may not take place. The user can read back the power-status flag at page 0/register 37, bit D7 and page 0/register 37, bit D3. When both the flags indicate power-down, the MDAC divider may be powered down, followed by the NDAC divider. Note that when the ADC clock dividers are powered down, the ADC clock is derived from the DAC clocks.

The ADC modulator is clocked by ADC_MOD_CLK. For proper power-up of the ADC Channel, these clocks are enabled by the NADC and MADC clock dividers (page 0/register 18, bit D7=1 and page 0/register 19, bit D7=1). When the ADC channel is powered down, the device internally initiates a power-down sequence for proper shut-down. During this shut-down sequence, the NADC and MADC dividers must not be powered down, or else a proper low power shut-down may not take place. The user can read back the power-status flag page 0/register 36, bit D6. When this flag indicates power-down, the MADC divider may be powered down, followed by NADC divider.

When ADC_CLK (ADC DSP clock) is derived from the NDAC divider output, the NDAC must be kept powered up till the power-down status flags for ADC do not indicate power-down. When the input to the AOSR clock divider is derived from DAC_MOD_CLK, then MDAC must be powered up when ADC_{f_s} is needed (i.e. when WCLK is generated by TSC2117 or AGC is enabled) and can be powered down only after the ADC power-down flags indicate power-down status.

In general, all the root clock dividers should be powered down only after the child clock dividers have been powered down for proper operation.

The TSC2117 also has options for routing some of the internal clocks to the output pins of the device to be used as general purpose clocks in the system. The feature is shown in [Figure 5-59](#).

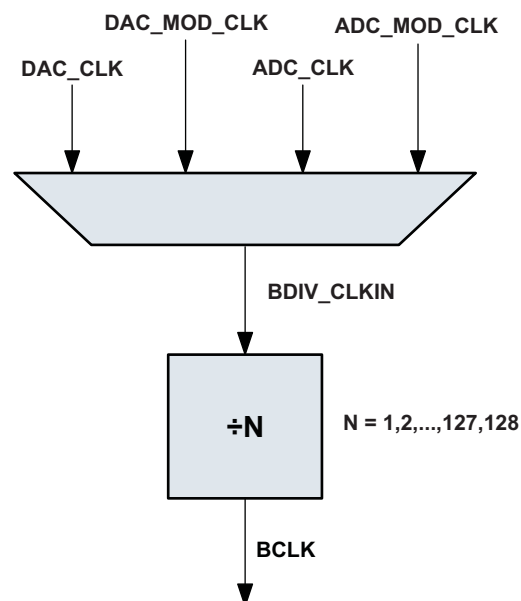
**Figure 5-59. BCLK Output Options**

In the mode when TSC2117 is configured to drive the BCLK pin (page 0/register 27, bit D3=1) it can be driven as divided value of BDIV_CLKIN. The division value can be programmed in page 0/register 30, D(6:0) from 1 to 128. The BDIV_CLKIN can itself be configured to be one of DAC_CLK (DAC DSP clock), DAC_MOD_CLK, ADC_CLK (ADC DSP clock) or ADC_MOD_CLK by configuring the BDIV_CLKIN mux in page 0/register 29, bits D1-D0. Additionally, a general-purpose clock can be driven out on either GPIO1, GPIO2, SDOUT, or MISO pin. This clock can be a divided down version of CDIV_CLKIN. The value of this clock divider can be programmed from 1 to 128 by writing to page 0/register 26, bits D6-D0. The CDIV_CLKIN can itself be programmed as one of the clocks among the list shown in Figure 5-60. This can be controlled by programming the mux in page 0/register 25, D(2:0).

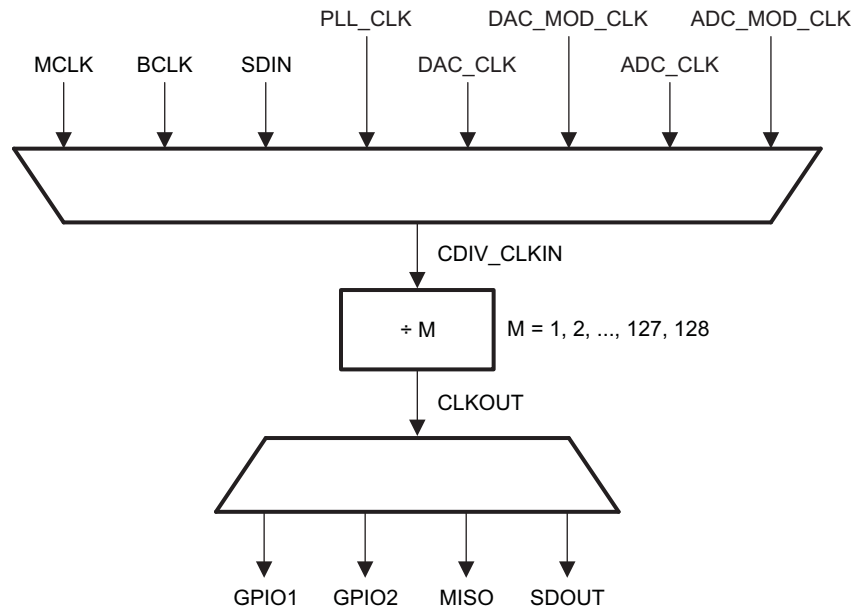

Figure 5-60. General-Purpose Clock Output Options

Table 5-42. Maximum TSC2117 Clock Frequencies

Clock	DVDD ≥ 1.65 V
CODEC_CLKIN	≤ 110 MHz
ADC_CLK (ADC DSP clock)	≤ 49.152 MHz
ADC_miniDSP_CLK	≤ 24.576 MHz
ADC_MOD_CLK	6.758 MHz
ADC _{fs}	0.192 MHz
DAC_CLK (DAC DSP clock)	≤ 49.152 MHz
DAC_miniDSP_CLK	≤ 49.152MHz with DRC disabled ≤ 48 MHz with DRC enabled
DAC_MOD_CLK	6.758 MHz
DAC _{fs}	0.192 MHz
BDIV_CLKIN	55 MHz
CDIV_CLKIN	100 MHz when M is odd 110 MHz when M is even

5.8.1 PLL

For lower power consumption it's best to derive the internal audio processing clocks using the simple dividers. When the input MCLK or other source clock is not an integer multiple of the audio processing clocks then it's necessary to use the on-board PLL. The TSC2117 fractional PLL can be used to generate an internal "master clock" used to produce the processing clocks needed by the ADC, DAC, and miniDSP. The programmability of this PLL allows operation from a wide variety of clocks that may be available in the system.

The PLL input supports clocks varying from 512kHz to 20MHz and is register programmable to enable generation of required sampling rates with fine resolution. The PLL can be turned on by writing to page 0/register 5, bit D7. When the PLL is enabled, the PLL output clock PLL_CLK is given by the following equation:

$$\text{PLL_CLK} = \frac{\text{PLL_CLKIN} \times R \times J.D}{P} \quad (15)$$

where

R = 1, 2, 3, ..., 16 (page 0/register 5, default value = 1)

J = 1, 2, 3, ..., 63, (page 0/register 6, default value = 4)

D = 0, 1, 2, ..., 9999 (page 0/register 7 and 8, default value = 0)

P = 1, 2, 3, ..., 8 (page 0/register 5, default value = 1)

The PLL can be turned on via page 0/register 5, bit D7. The variable P can be programmed via page 0/register 5, bit D6-D4. The variable R can be programmed via page 0/register 5, bit D3-D0. The variable J can be programmed via page 0/register 6, bit D5-D0. The variable D is 14-bits and is programmed into two registers. The MSB portion can be programmed via page 0/register 7, bit D5-D0, and the LSB portion is programmed via page 0/register 8, bit D7-D0. For proper update of the D-divider value, page 0/register 7 must be programmed first followed immediately by page 0/register 8. Unless the write to page 0/register 8 is completed, the new value of D will not take effect.

When the PLL is enabled the following conditions must be satisfied:

- When the PLL is enabled and D = 0, the following conditions must be satisfied for PLL_CLKIN:

$$512\text{kHz} \leq \frac{\text{PLL_CLKIN}}{P} \leq 20\text{MHz} \quad (16)$$

$$80\text{ MHz} \leq (\text{PLL_CLKIN} \times J.D \times R/P) \leq 110\text{ MHz}$$

$$4 \leq R \times J \leq 259$$

- When the PLL is enabled and D ≠ 0, the following conditions must be satisfied for PLL_CLKIN:

$$10\text{MHz} \leq \frac{\text{PLL_CLKIN}}{P} \leq 20\text{MHz} \quad (17)$$

$$80\text{ MHz} \leq \text{PLL_CLKIN} \times J.D \times R/P \leq 110\text{ MHz}$$

$$R = 1$$

The PLL can be powered up independently from the ADC and DAC blocks, and can also be used as a general purpose PLL by routing its output to the GPIO output. After powering up the PLL, PLL_CLK is available typically after 10 ms.

The clocks for codec and various signal processing blocks, CODEC_CLKIN can be generated from MCLK input, BCLK input, GPIO input or PLL_CLK (page 0/register 4, bit D1-D0).

If the CODEC_CLKIN is derived from the PLL, then the PLL must be powered up first and powered down last.

Table 5-43 lists several example cases of typical PLL_CLKIN rates and how to program the PLL to achieve a sample rate f_s of either 44.1 kHz or 48 kHz.

Table 5-43. PLL Example Configurations

$f_s = 44.1 \text{ kHz}$										
PLL_CLKIN (MHz)	PLL_P	PLL_R	PLL_J	PLL_D	MADC	NADC	AOSR	MDAC	NDAC	DOSR
2.8224	1	3	10	0	3	5	128	3	5	128
5.6448	1	3	5	0	3	5	128	3	5	128
12	1	1	7	560	3	5	128	3	5	128
13	1	1	6	3504	2	9	104	6	3	104
16	1	1	5	2920	3	5	128	3	5	128
19.2	1	1	4	4100	3	5	128	3	5	128
48	4	1	7	560	3	5	128	3	5	128
$f_s = 48 \text{ kHz}$										
2.048	1	3	14	0	2	7	128	7	2	128
3.072	1	4	7	0	2	7	128	7	2	128
4.096	1	3	7	0	2	7	128	7	2	128
6.144	1	2	7	0	2	7	128	7	2	128
8.192	1	4	3	0	2	8	128	4	4	128
12	1	1	7	1680	2	7	128	7	2	128
16	1	1	5	3760	2	7	128	7	2	128
19.2	1	1	4	4800	2	7	128	7	2	128
48	4	1	7	1680	2	7	128	7	2	128

5.8.2 Timer

The internal clock runs nominally at 8.2MHz. This is used for various internal timing intervals, de-bounce logics and interrupts. The MCLK divider must be set such a way that the divider output is ~1MHz for the timers to be closer to the programmed value.

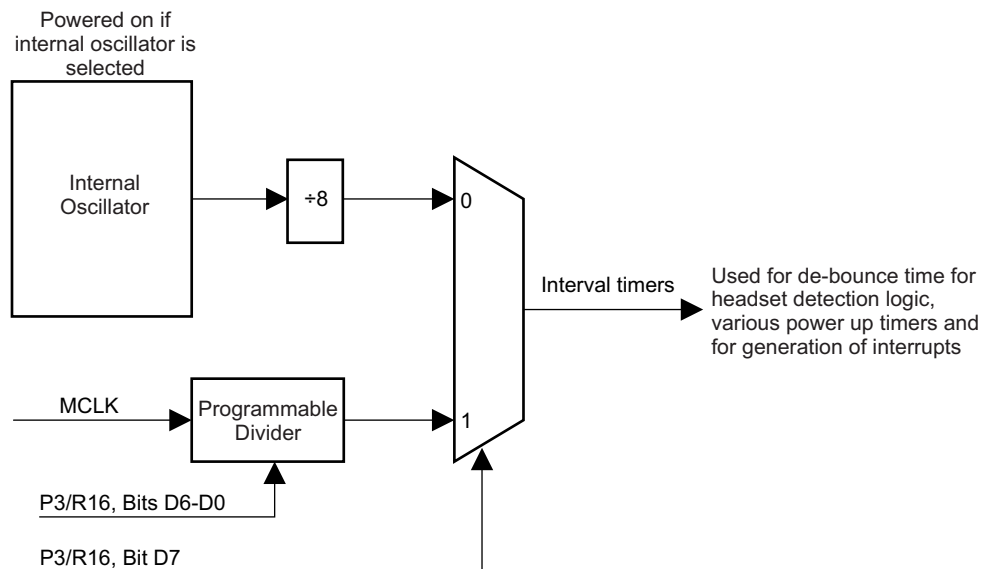

Figure 5-61. Interval Timer Clock Selection

5.9 Digital Audio and Control Interface

5.9.1 Digital Audio Interface

Audio data is transferred between the host processor and the TSC2117 via the digital audio data serial interface, or audio bus. The audio bus on this device is very flexible, including left or right-justified data options, support for I²S or PCM protocols, programmable data length options, a TDM mode for multichannel operation, very flexible master/slave configurability for each bus clock line, and the ability to communicate with multiple devices within a system directly.

The audio bus of the TSC2117 can be configured for left or right-justified, I²S, DSP, or TDM modes of operation, where communication with standard telephony PCM interfaces is supported within the TDM mode. These modes are all MSB-first, with data width programmable as 16, 20, 24, or 32 bits by configuring page 0/register 27, D(5:4). In addition, the word clock and bit clock can be independently configured in either Master or Slave mode, for flexible connectivity to a wide variety of processors. The word clock is used to define the beginning of a frame, and may be programmed as either a pulse or a square-wave signal. The frequency of this clock corresponds to the maximum of the selected ADC and DAC sampling frequencies.

The bit clock is used to clock in and clock out the digital audio data across the serial bus. When in Master mode, this signal can be programmed to generate variable clock pulses by controlling the bit-clock divider in page 0/register 30 (see [Figure 5-58](#)). The number of bit-clock pulses in a frame may need adjustment to accommodate various word-lengths as well as to support the case when multiple TSC2117s may share the same audio bus.

The TSC2117 also includes a feature to offset the position of start of data transfer with respect to the word-clock. This offset can be controlled in terms of number of bit-clocks and can be programmed in page 0/register 28.

The TSC2117 also has the feature of inverting the polarity of the bit-clock used for transferring the audio data as compared to the default clock polarity used. This feature can be used independently of the mode of audio interface chosen. This can be configured via page 0/register 29, D(3).

The TSC2117 further includes programmability (page 0/register 27, D0) to 3-state the SDOOUT line during all bit clocks when valid data is not being sent. By combining this capability with the ability to program at what bit clock in a frame the audio data begins, time-division multiplexing (TDM) can be accomplished, enabling the use of multiple codecs on a single audio serial data bus. When the audio serial data bus is powered down while configured in master mode, the pins associated with the interface are put into a 3-state output condition.

By default when the word-clocks and bit-clocks are generated by the TSC2117, these clocks are active only when the codec (ADC, DAC or both) are powered up within the device. This is done to save power. However, it also supports a feature when both the word clocks and bit-clocks can be active even when the codec in the device is powered down. This is useful when using the TDM mode with multiple codecs on the same bus, or when word-clock or bit-clocks are used in the system as general-purpose clocks.

5.9.1.1 Right-Justified Mode

The audio interface of the TSC2117 can be put into right-justified mode by programming page 0/register 27, D(7:6) = 10. In right-justified mode, the LSB of the left channel is valid on the rising edge of the bit clock preceding the falling edge of the word clock. Similarly, the LSB of the right channel is valid on the rising edge of the bit clock preceding the rising edge of the word clock.

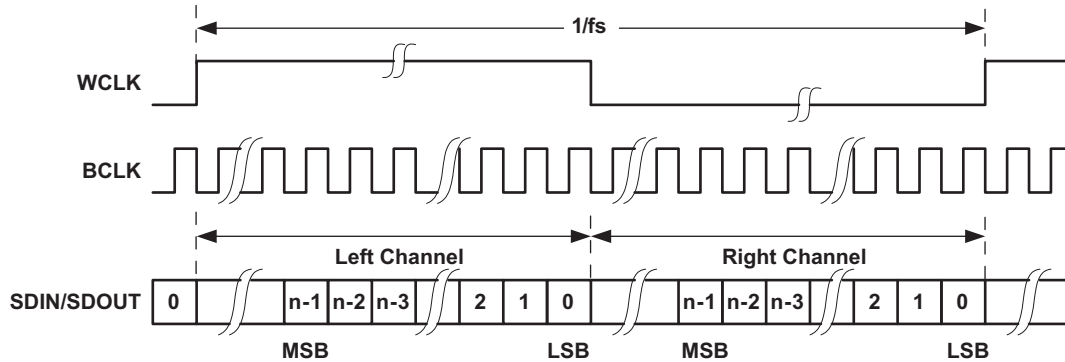

Figure 5-62. Timing Diagram for Right-Justified Mode

For right-justified mode, the number of bit-clcks per frame should be greater than or equal to twice the programmed word-length of the data.

5.9.1.2 Left-Justified Mode

The audio interface of the TSC2117 can be put into left-justified mode by programming page 0/register 27, D(7:6) = 11. In left-justified mode, the MSB of the right channel is valid on the rising edge of the bit clock following the falling edge of the word clock. Similarly the MSB of the left channel is valid on the rising edge of the bit clock following the rising edge of the word clock.

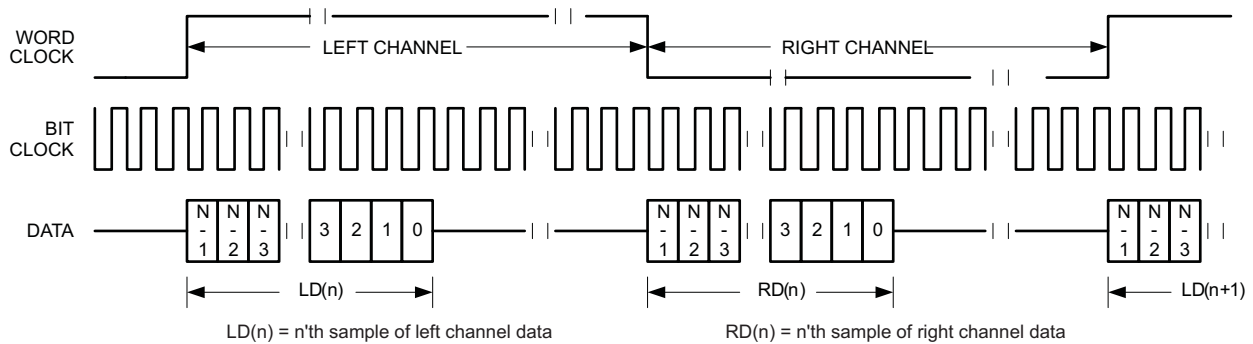

Figure 5-63. Timing Diagram for Left-Justified Mode

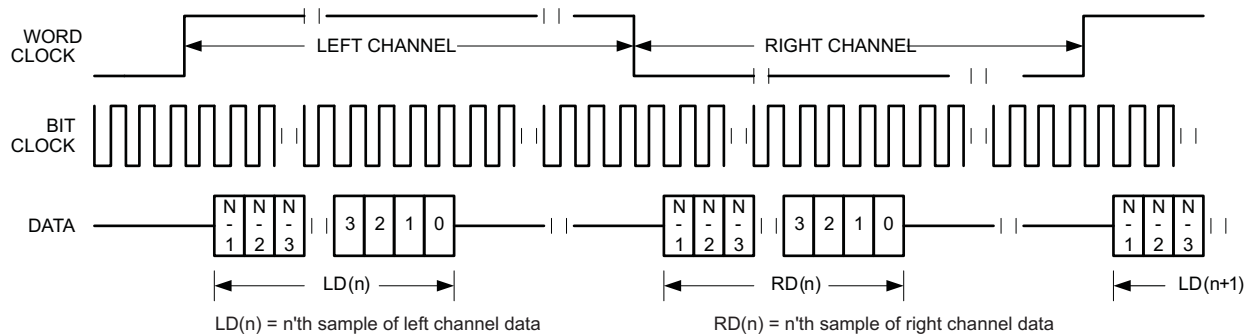

Figure 5-64. Timing Diagram for Left-Justified Mode with Offset=1

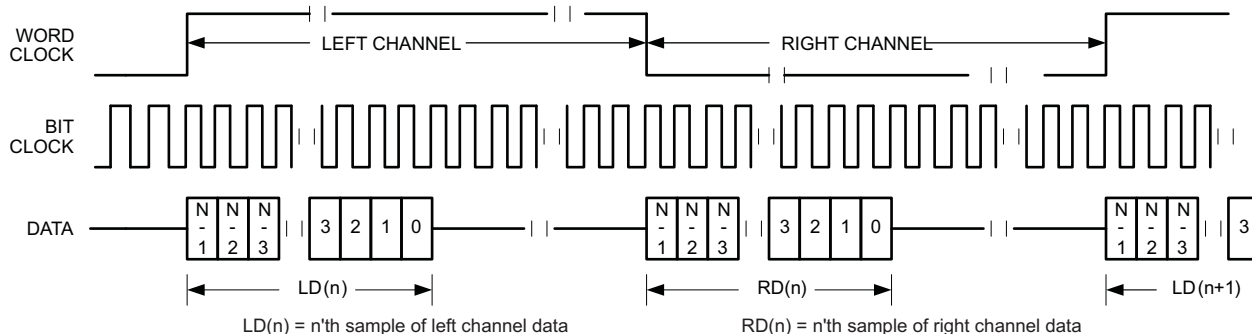

Figure 5-65. Timing Diagram for Left-Justified Mode with Offset=0 and inverted bit clock

For Left-Justified mode, the number of bit-clcks per frame should be greater than or equal to twice the programmed word-length of the data. Also, the programmed offset value should be less than the number of bit-clcks per frame by at least the programmed word-length of the data.

5.9.1.3 I²S Mode

The audio interface of the TSC2117 can be put into I²S mode by programming page 0/register 27, D(7:6) = to 00. In I²S mode, the MSB of the left channel is valid on the second rising edge of the bit clock after the falling edge of the word clock. Similarly, the MSB of the right channel is valid on the second rising edge of the bit clock after the rising edge of the word clock.

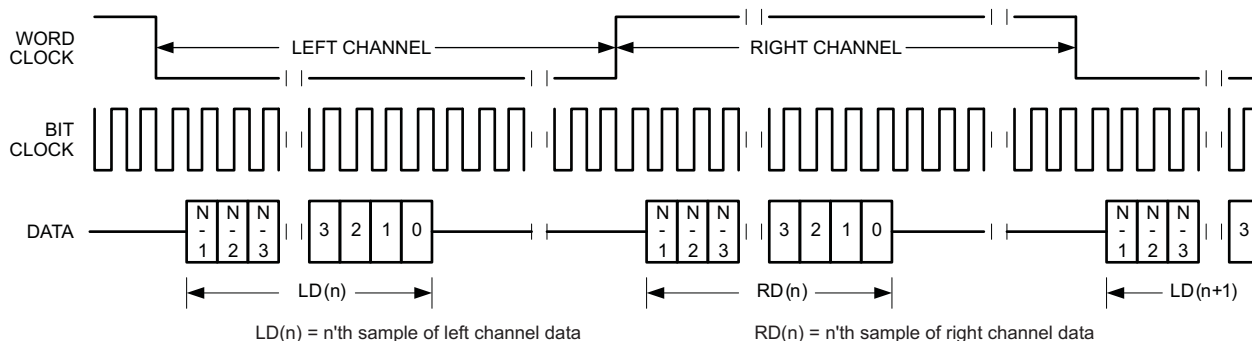

Figure 5-66. Timing Diagram for I²S Mode

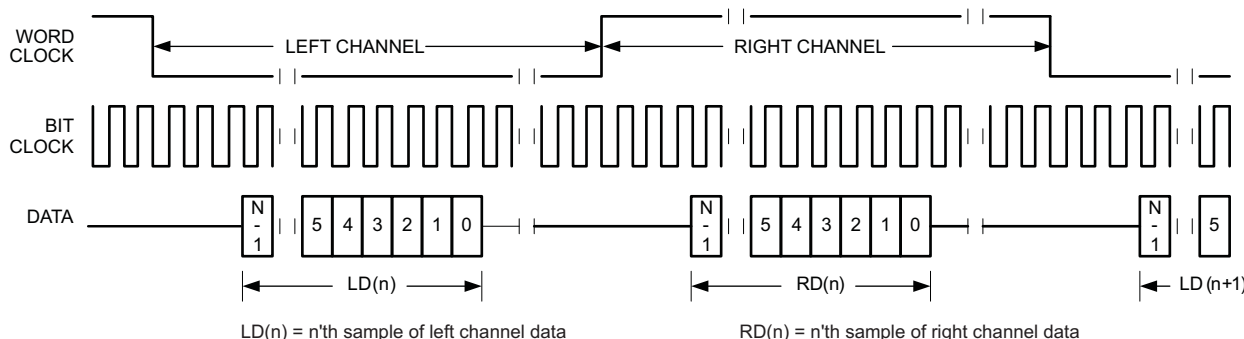

Figure 5-67. Timing Diagram for I²S Mode with offset=2

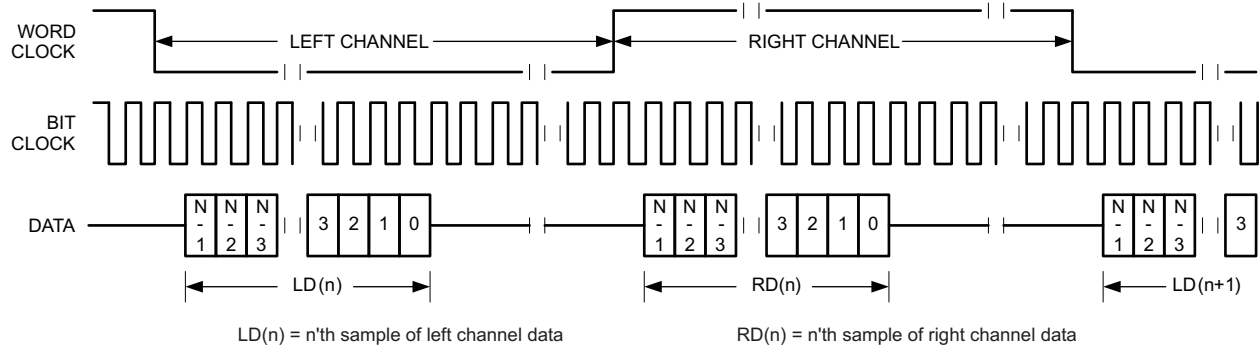

Figure 5-68. Timing Diagram for I²S Mode with offset=0 and bit clock invert

For I²S mode, the number of bit-clocks per channel should be greater than or equal to the programmed word-length of the data. Also the programmed offset value should be less than the number of bit-clocks per frame by at least the programmed word-length of the data.

Figure 5-69 shows the timing diagram for I²S mode for the monoaural audio ADC.

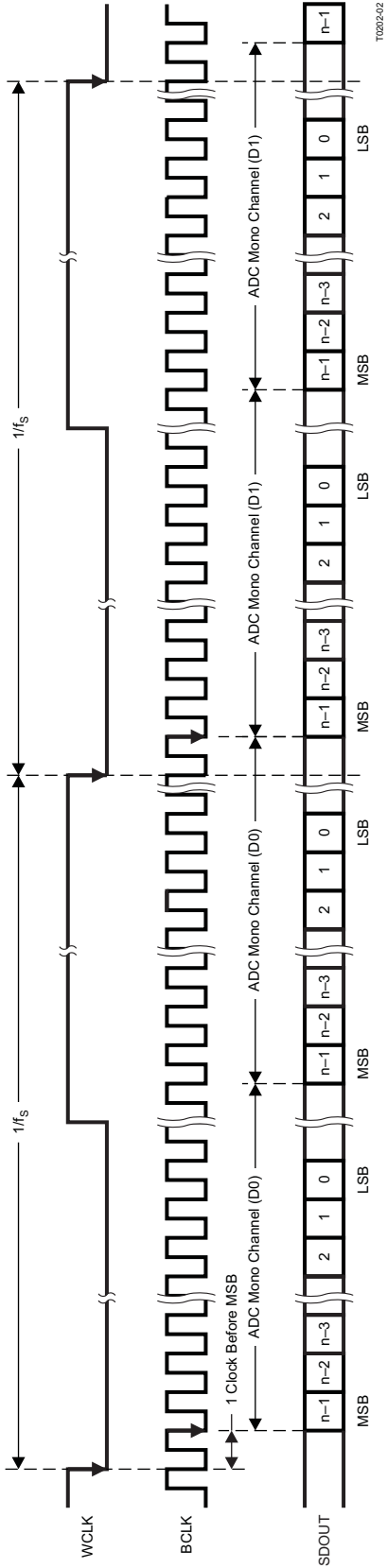

Figure 5-69. Timing Diagram for I²S Mode for Monoaural Audio ADC

5.9.1.4 DSP Mode

The audio interface of the TSC2117 can be put into DSP mode by programming page 0/register 27, D(7:6) = 01. In DSP mode, the falling edge of the word clock starts the data transfer with the left channel data first and immediately followed by the right channel data. Each data bit is valid on the falling edge of the bit clock.

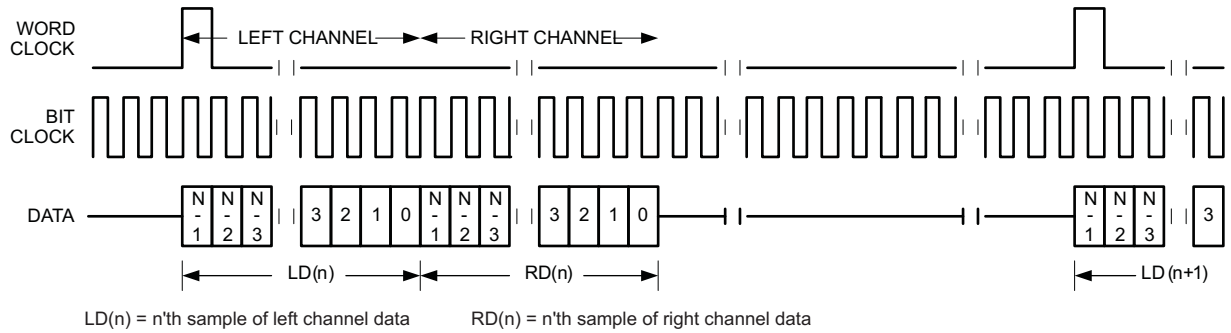

Figure 5-70. Timing Diagram for DSP Mode

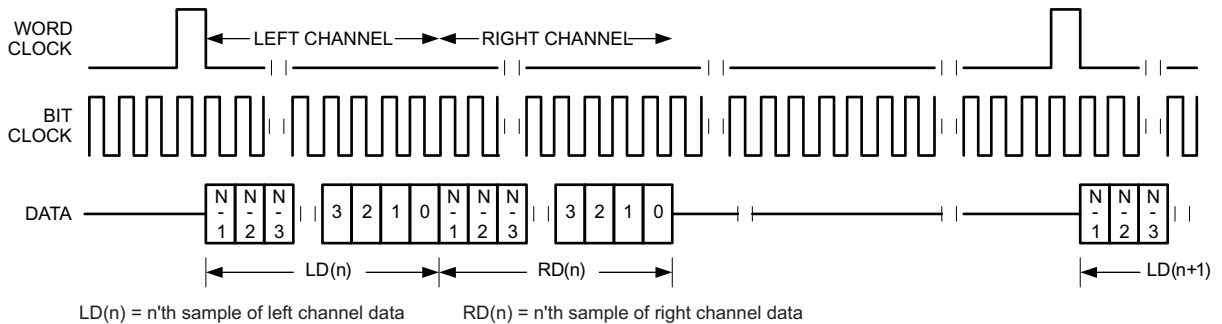

Figure 5-71. Timing Diagram for DSP Mode With Offset = 1

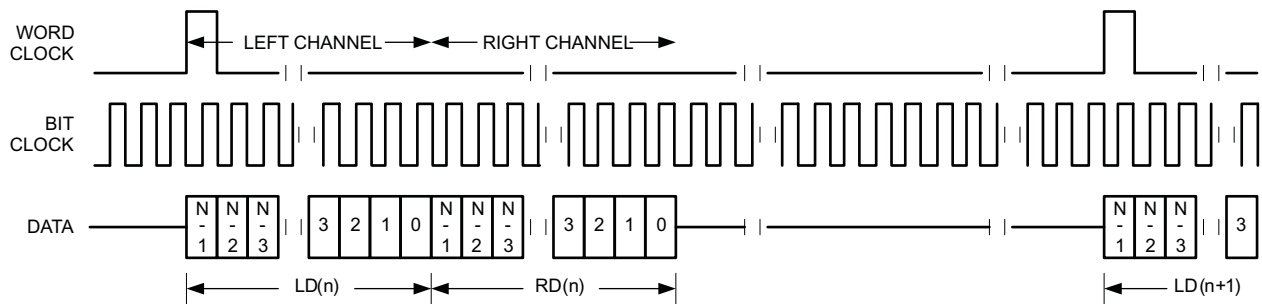

Figure 5-72. Timing Diagram for DSP Mode With Offset = 0 and Bit Clock Inverted

For DSP mode, the number of bit-clcks per frame should be greater than or equal to twice the programmed word-length of the data. Also the programmed offset value should be less than the number of bit-clcks per frame by at least the programmed word-length of the data.

5.9.2 Primary and Secondary Digital Audio Interface Selection

The audio serial interface on the TSC2117 has extensive IO control to allow communication with two independent processors for audio data. Each processor can communicate with the device one at a time. This feature is enabled by register programming of the various pin selections. [Table 5-44](#) shows the Primary and Secondary Audio Interface Selection and Registers. [Table 5-45](#) shows the selection criteria for generating ADC_WCLK. [Figure 5-73](#) is a high-level diagram showing the general signal flow and multiplexing for Primary and Secondary Audio Interfaces. For detail information reference the tables and register definitions.

Table 5-44. Primary and Secondary Audio Interface Selection

Desired Pin Function	Possible Pins	Page 0 Registers	Comment
Primary WCLK (OUT)	WCLK	R27/D2 = 1	Primary WCLK is output from codec
		R33/D5–D4	Select source of Primary WCLK (DAC_fs, ADC_fs, or Secondary WCLK)
Primary WCLK (IN)	WCLK	R27/D2 = 0	Primary WCLK is input to codec
Primary BCLK (OUT)	BCLK	R27/D3 = 1	Primary BCLK is output from codec
		R33/D7	Select source of Primary WCLK (internal BCLK or Secondary BCLK)
Primary BCLK (IN)	BCLK	R27/D3 = 0	Primary BCLK is input to codec
Primary SDIN (IN)	SDIN	R32/D0	Select SDIN to internal interface (0=Primary SDIN; 1=Secondary SDIN)
Primary SDOUT (OUT)	SDOUT	R53/D3–D1 = 001	SDOUT = primary SDOUT for codec interface
		R33/D1	Select source for SDOUT (0 = SDOUT from Interface Block; 1 = secondary SDIN)
Secondary WCLK (OUT)	GPIO1	R31/D4–D2 = 000	Secondary WCLK obtained from GPIO1 pin
		R51/D5–D2 = 1001	GPIO1 = Secondary WCLK output
		R33/D3–D2	Select source of Secondary WCLK (DAC_fs, ADC_fs, or Primary WCLK)
	MISO	R31/D4–D2 = 010	Secondary WCLK obtained from MISO pin
		R55/D4–D1 = 1010	MISO = Secondary WCLK output
		R33/D3–D2	Select source of Secondary WCLK (DAC_fs, ADC_fs, or Primary WCLK)
	SDOUT	R31/D4–D2 = 011	Secondary WCLK obtained from SDOUT pin
		R53/D3–D1 = 111	SDOUT = Secondary WCLK output
		R33/D3–D2	Select source of Secondary WCLK (DAC_fs, ADC_fs, or Primary WCLK)
	GPIO2	R31/D4–D2 = 100	Secondary WCLK obtained from GPIO2 pin
		R52/D5–D2 = 1001	GPIO2 = Secondary WCLK output
		R33/D3–D2	Select source of Secondary WCLK (DAC_fs, ADC_fs, or Primary WCLK)
Secondary WCLK (IN)	GPIO1	R31/D4–D2 = 000	Secondary WCLK obtained from GPIO1 pin
		R51/D5–D2 = 0001	GPIO1 enabled as Secondary input
	SCLK	R31/D4–D2 = 001	Secondary WCLK obtained from SCLK pin
		R56/D2–D1 = 11	SCLK enabled as Secondary input
	GPIO2	R31/D4–D2 = 100	Secondary WCLK obtained from GPIO2 pin
		R52/D5–D2 = 0001	GPIO2 enabled as Secondary input
	GPI1	R31/D4–D2 = 101	Secondary WCLK obtained from GPI1 pin
		R57/D6–D5 = 01	GPI1 enabled as Secondary input
	GPI2	R31/D4–D2 = 110	Secondary WCLK obtained from GPI2 pin
		R57/D2–D1 = 01	GPI2 enabled as Secondary input
	GPI3	R31/D4–D2 = 111	Secondary WCLK obtained from GPI3 pin
		R58/D6–D5 = 01	GPI3 enabled as Secondary input

Table 5-44. Primary and Secondary Audio Interface Selection (continued)

Desired Pin Function	Possible Pins	Page 0 Registers	Comment
Secondary BCLK (OUT)	GPIO1	R31/D7–D5 = 000	Secondary BCLK obtained from GPIO1 pin
		R51/D5–D2 = 1000	GPIO1 = Secondary BCLK output
		R33/D6	Select source of Secondary BCLK (primary BCLK or internal BCLK)
	MISO	R31/D7–D5 = 010	Secondary BCLK obtained from MISO pin
		R55/D4–D1 = 1001	MISO = Secondary BCLK output
		R33/D6	Select source of Secondary BCLK (0=primary BCLK ; 1=internal BCLK)
	SDOUT	R31/D7–D5 = 011	Secondary BCLK obtained from SDOUT pin
		R53/D3–D1 = 110	SDOUT = Secondary BCLK output
		R33/D6	Select source of Secondary BCLK (primary BCLK or internal BCLK)
	GPIO2	R31/D7–D5 = 100	Secondary BCLK obtained from GPIO2 pin
		R52/D5–D2 = 1000	GPIO2 = Secondary BCLK output
		R33/D6	Select source of Secondary BCLK (primary BCLK or internal BCLK)
Secondary BCLK (IN)	GPIO1	R31/D7–D5 = 000	Secondary BCLK obtained from GPIO1 pin
		R51/D5–D2 = 0001	GPIO1 enabled as Secondary input
	SCLK	R31/D7–D5 = 001	Secondary BCLK obtained from SCLK pin
		R56/D2–D1 = 11	SCLK enabled as Secondary input
	GPIO2	R31/D7–D5 = 100	Secondary BCLK obtained from GPIO2 pin
		R52/D5–D2 = 0001	GPIO2 enabled as Secondary input
	GPI1	R31/D7–D5 = 101	Secondary BCLK obtained from GPI1 pin
		R57/D6–D5 = 01	GPI1 enabled as Secondary input
	GPI2	R31/D7–D5 = 110	Secondary BCLK obtained from GPI2 pin
		R57/D2–D1 = 01	GPI2 enabled as Secondary input
	GPI3	R31/D7–D5 = 111	Secondary BCLK obtained from GPI3 pin
		R58/D6–D5 = 01	GPI3 enabled as Secondary input
Secondary SDIN (IN)	GPIO1	R31/D1–D0 = 00	Secondary SDIN obtained from GPIO1 pin
		R51/D5–D2 = 0001	GPIO1 enabled as Secondary input
	SCLK	R31/D1–D0 = 01	Secondary SDIN obtained from SCLK pin
		R56/D2–D1 = 11	SCLK enabled as Secondary input
	GPIO2	R31/D1–D0 = 10	Secondary SDIN obtained from GPIO2 pin
		R52/D5–D2 = 0001	GPIO2 enabled as Secondary input
	GPI1	R31/D1–D0 = 11	Secondary SDIN obtained from GPI1 pin
		R57/D6–D5 = 01	GPI1 enabled as Secondary input
Secondary SDOUT (OUT)	GPIO1	R51/D5–D2 = 1011	GPIO1 = Secondary SDOUT
		R33/D0	Select Source for Secondary SDOUT (0 = primary SDIN; 1 = SDOUT from interface block)
	GPIO2	R52/D5–D2 = 1011	GPIO2 = Secondary SDOUT
		R33/D0	Select Source for Secondary SDOUT (0 = primary SDIN; 1 = SDOUT from interface block)
	MISO	R55/D4–D1 = 1000	MISO = Secondary SDOUT
		R33/D0	Select Source for Secondary SDOUT (0 = primary SDIN; 1 = SDOUT from interface block)

Table 5-45. Generation of ADC_WCLK

ADC_WCLK Direction	Possible Pins	Page 0 Registers	Comment
OUTPUT	GPIO1	R32/D7–D5 = 000	ADC_WCLK obtained from GPIO1 pin
		R51/D5–D2 = 0111	GPIO1 = ADC_WCLK
		R32/D1	Select source of Internal ADC_WCLK (0 = DAC_WCLK; 1 = ADC_WCLK)
	MISO	R32/D7–D5 = 010	ADC_WCLK obtained from MISO pin
		R55/D4–D1 = 0110	MISO = ADC_WCLK
		R32/D1	Select source of Internal ADC_WCLK (0 = DAC_WCLK; 1 = ADC_WCLK)
	GPIO2	R32/D7–D5 = 100	ADC_WCLK obtained from GPIO2 pin
		R52/D5–D2 = 0111	GPIO2 = ADC_WCLK
		R32/D1	Select source of Internal ADC_WCLK (0 = DAC_WCLK; 1 = ADC_WCLK)
INPUT	GPIO1	R32/D7–D5 = 000	ADC_WCLK obtained from GPIO1 pin
		R51/D5–D2 = 0001	GPIO1 enabled as Secondary input
		R32/D1	Select source of Internal ADC_WCLK (0 = DAC_WCLK; 1 = ADC_WCLK)
	SCLK	R32/D7–D5 = 001	ADC_WCLK obtained from SCLK pin
		R56/D2–D1 = 11	SCLK enabled as Secondary input
		R32/D1	Select source of Internal ADC_WCLK (0 = DAC_WCLK; 1 = ADC_WCLK)
	GPIO2	R32/D7–D5 = 100	ADC_WCLK obtained from GPIO2 pin
		R52/D5–D2 = 0001	GPIO2 enabled as Secondary input
		R32/D1	Select source of Internal ADC_WCLK (0 = DAC_WCLK; 1 = ADC_WCLK)
	GPI1	R32/D7–D5 = 101	ADC_WCLK obtained from GPI1 pin
		R57/D6–D5 = 01	GPI1 enabled as Secondary Input
		R32/D1	Select source of Internal ADC_WCLK (0 = DAC_WCLK; 1 = ADC_WCLK)
	GPI2	R32/D7–D5 = 110	ADC_WCLK obtained from GPI2 pin
		R57/D2–D1 = 01	GPI2 enabled as Secondary Input
		R32/D1	Select source of Internal ADC_WCLK (0 = DAC_WCLK; 1 = ADC_WCLK)
	GPI3	R32/D7–D5 = 111	ADC_WCLK obtained from GPI3 pin
		R58/D6–D5 = 01	GPI3 enabled as Secondary Input
		R32/D1	Select source of Internal ADC_WCLK (0 = DAC_WCLK; 1 = ADC_WCLK)

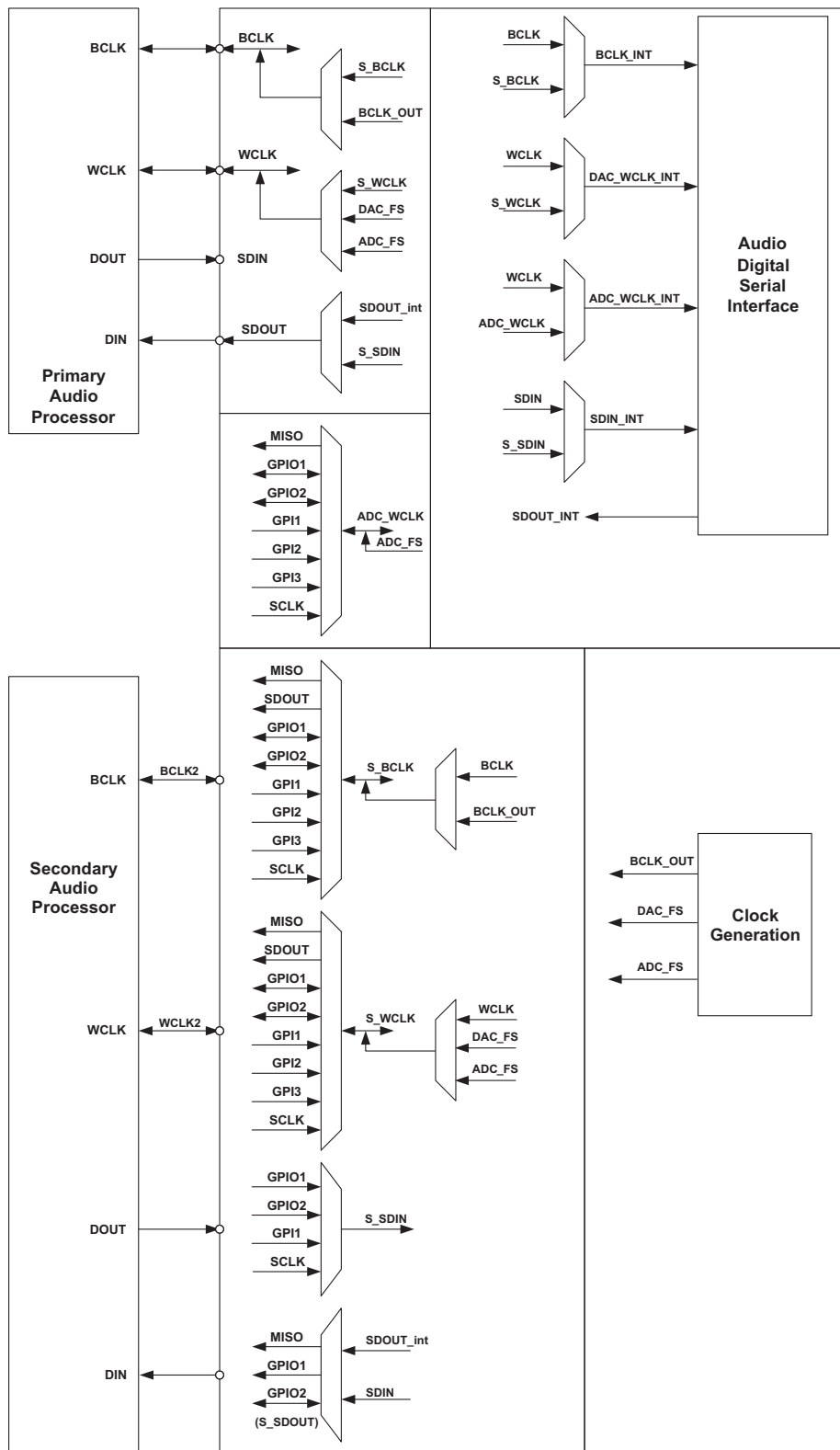

Figure 5-73. Audio Serial Interface Multiplexing

5.9.3 Control Interface

The TSC2117 control interface supports SPI and I²C communication protocols, which are both available simultaneously, but it is recommended to make only one of them active at any given time.

5.9.3.1 I²C Control Mode

The TSC2117 supports the I²C control protocol, and will respond to the I²C address of 0011000. I²C is a two-wire, open-drain interface supporting multiple devices and masters on a single bus. Devices on the I²C bus only drive the bus lines LOW by connecting them to ground; they never drive the bus lines HIGH. Instead, the bus wires are pulled HIGH by pullup resistors, so the bus wires are HIGH when no device is driving them LOW. This way, two devices cannot conflict; if two devices drive the bus simultaneously, there is no driver contention.

Communication on the I²C bus always takes place between two devices, one acting as the master and the other acting as the slave. Both masters and slaves can read and write, but slaves can only do so under the direction of the master. Some I²C devices can act as masters or slaves, but the TSC2117 can only act as a slave device.

An I²C bus consists of two lines, SDA and SCL. SDA carries data, and the SCL signal provides the clock. All data is transmitted across the I²C bus in groups of eight bits. To send a bit on the I²C bus, the SDA line is driven to the appropriate level while SCL is LOW (a LOW on SDA indicates the bit is zero, while a HIGH indicates the bit is one).

Once the SDA line has settled, the SCL line is brought HIGH, then LOW. This pulse on the SCL line clocks the SDA bit into the receiver's shift register.

The I²C bus is bidirectional: the SDA line is used both for transmitting and receiving data. When a master reads from a slave, the slave drives the data line; when a master sends to a slave, the master drives the data line.

Most of the time the bus is idle, no communication is taking place, and both lines are HIGH. When communication is taking place, the bus is active. Only master devices can start communication on the bus. Normally, the data line is only allowed to change state while the clock line is LOW. If the data line changes state while the clock line is HIGH, it is either a START condition or its counterpart, a STOP condition. A START condition is when the clock line is HIGH and the data line goes from HIGH to LOW. A STOP condition is when the clock line is HIGH and the data line goes from LOW to HIGH.

After the master issues a START condition, it sends a byte that selects the slave device for communication. This byte is called the address byte. Each device on an I²C bus has a unique 7-bit address to which it responds. (Slaves can also have 10-bit addresses; see the I²C specification for details.) The master sends an address in the address byte, together with a bit that indicates whether it wishes to read from or write to the slave device.

Every byte transmitted on the I²C bus, whether it is address or data, is acknowledged with an acknowledge bit. When a master has finished sending a byte (eight data bits) to a slave, it stops driving SDA and waits for the slave to acknowledge the byte. The slave acknowledges the byte by pulling SDA LOW. The master then sends a clock pulse to clock the acknowledge bit. Similarly, when a master has finished reading a byte, it pulls SDA LOW to acknowledge this to the slave. It then sends a clock pulse to clock the bit. (Remember that the master always drives the clock line.)

A not-acknowledge is performed by simply leaving SDA HIGH during an acknowledge cycle. If a device is not present on the bus, and the master attempts to address it, it will receive a not-acknowledge because no device is present at that address to pull the line LOW.

When a master has finished communicating with a slave, it may issue a STOP condition. When a STOP condition is issued, the bus becomes idle again. A master may also issue another START condition. When a START condition is issued while the bus is active, it is called a repeated START condition.

The TSC2117 can also respond to and acknowledge a General Call, which consists of the master issuing a command with a slave address byte of 00H. This feature is disabled by default, but can be enabled via page 0/register 34, bit D5.

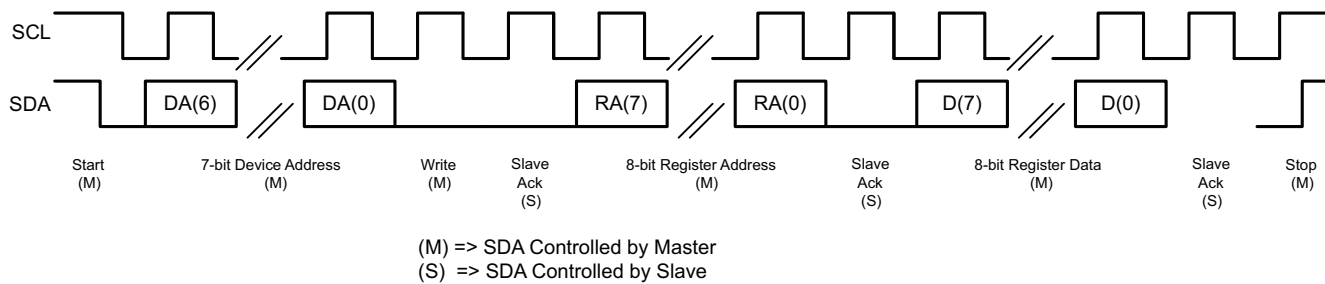

Figure 5-74. I²C Write

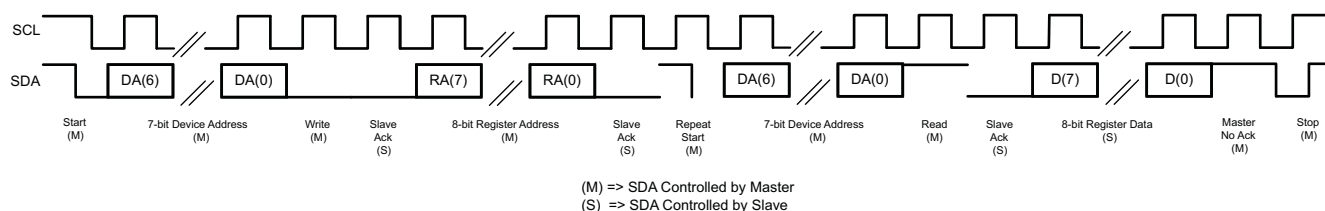

Figure 5-75. I²C Read

In the case of an I²C register write, if the master does not issue a STOP condition, then the device enters auto-increment mode. So in the next eight clocks, the data on SDA is treated as data for the next incremental register.

Similarly, in the case of an I²C register read, after the device has sent out the 8-bit data from the addressed register, if the master issues a ACKNOWLEDGE, the slave takes over control of SDA bus and transmit for the next 8 clocks the data of the next incremental register.

5.9.3.2 SPI Digital Interface

In the SPI control mode, the TSC2117 uses the pins SCLK, \overline{SS} , MISO, and MOSI as a standard SPI port with clock polarity setting of 0 (typical microprocessor SPI control bit CPOL = 0). The SPI port allows full-duplex, synchronous, serial communication between a host processor (the master) and peripheral devices (slaves). The SPI master (in this case, the host processor) generates the synchronizing clock (driven onto SCLK) and initiates transmissions. The SPI slave devices (such as the TSC2117) depend on a master to start and synchronize transmissions. A transmission begins when initiated by an SPI master. The byte from the SPI master begins shifting in on the slave MOSI pin under the control of the master serial clock (driven onto SCLK). As the byte shifts in on the MOSI pin, a byte shifts out on the MISO pin to the master shift register.

The TSC2117 interface is designed so that with a clock-phase bit setting of 1 (typical microprocessor SPI control bit CPHA = 1), the master begins driving its MOSI pin and the slave begins driving its MISO pin on the first serial clock edge. The \overline{SS} pin can remain low between transmissions; however, the TSC2117 only interprets the first 8 bits transmitted after the falling edge of \overline{SS} as a command byte, and the next 8 bits as a data byte only if writing to a register. Reserved register bits should be written to their default values. The TSC2117 is entirely controlled by registers. Reading and writing these registers is accomplished by an 8-bit command sent to the MOSI pin of the part prior to the data for that register. The command is structured as shown in Table 5-46. The first 7 bits specify the register address which is being written or read, from 0 to 127 (decimal). The command word ends with an R/W bit, which specifies the direction of data flow on

the serial bus. In the case of a register write, the R/W bit should be set to 0. A second byte of data is sent to the MOSI pin and contains the data to be written to the register. Reading of registers is accomplished in similar fashion. The 8-bit command word sends the 7-bit register address, followed by R/W bit = 1 to signify a register read is occurring. The 8-bit register data is then clocked out of the part on the MISO pin during the second 8 SCLK clocks in the frame.

Table 5-46.

COMMAND WORD							
Bit 7	Bit 6	Bit 5	Bit 4	Bit 3	Bit 2	Bit 1	Bit 0
ADDR(6)	ADDR(5)	ADDR(4)	ADDR(3)	ADDR(2)	ADDR(1)	ADDR(0)	R/W

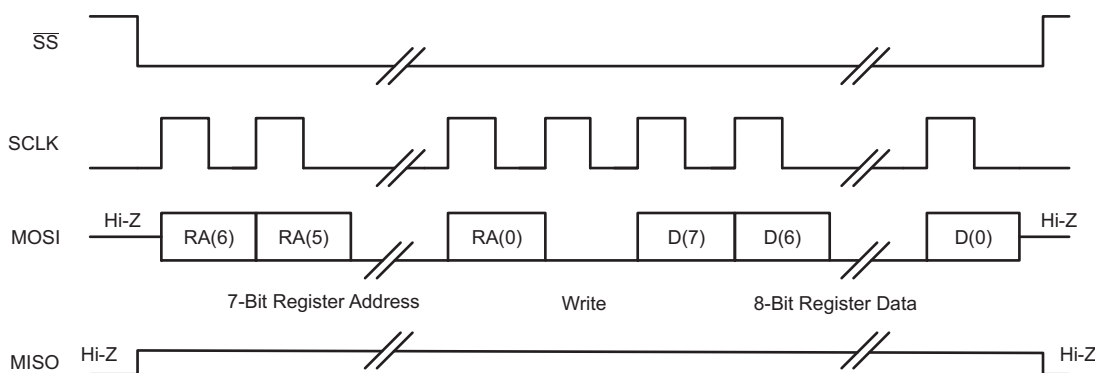

Figure 5-76. SPI Timing Diagram for Register Write

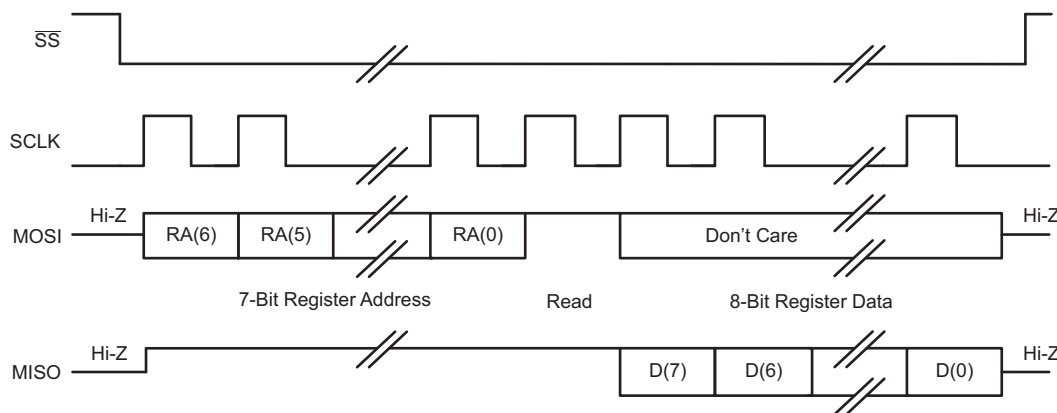

Figure 5-77. SPI Timing Diagram for Register Read

Register read/write is supported for all control registers for the register pages that are shown in the register map.

Auto-increment of the register read/write is supported for all the registers within a single page. At the end of a page boundary (register 127), auto-incrementing stops. Therefore, further writes overwrite register 127, and further reads read back register 127 again and again.

The buffer registers are a special case, so that the auto-increment function allows all of the buffer data to be read on page 252, using registers 1 and 2. Therefore it reads register 1, register 2, register 1, register 2, register 1, register 2, ... until the buffer has been read.

6 REGISTER MAP

6.1 TSC2117 Register Map

All features on this device can be addressed using the I²C bus or the SPI bus. **However, it is not recommended to use the I²C bus and the SPI bus simultaneously for updating register values.** All of the writable registers can be read back. However, some registers contain status information or data, and are available for reading only.

The TSC2117 contains several pages of 8-bit registers, and each page can contain up to 128 registers. The register pages are divided up based on functional blocks for this device. The pages defined for the TSC2117 are 0, 1, 3, 4–5 (ADC coefficient pages), and 8–15 (DAC coefficient pages), 32–43 (ADC IRAM pages), 64–95 (DAC IRAM pages), and 252 (SAR buffer data page). Page 0 is the default home page after RESET. Page control is done by writing a new page value into register 0 of the current page.

The control registers for the TSC2117 are described in detail as follows. All registers are 8 bits in width, with D7 referring to the most-significant bit of each register, and D0 referring to the least-significant bit.

Pages 0, 1, 3, 4–5, 8–15, 32–43, 64–95, and 252 are available. All other pages are reserved. Do not read from or write to reserved pages and registers. Also, do not write other than the reset values for the reserved bits and read-only bits of non-reserved registers; otherwise, device functionality failure can occur.

Table 6-1. Summary of Register Map

Page Number	Description
0	Page 0 is the default page on power up. Configuration for serial interface, digital I/O, clocking, ADC, DAC miniDSP settings, etc.
1	Configuration for analog PGAs, ADC, DAC, output drivers, volume controls, etc.
3	Configuration for 12-bit SAR converter settings and touch-screen settings
4–5	ADC AGC and filter coefficients
8–15	DAC filter and DRC coefficients
32–43	ADC instruction RAM locations
64–95	DAC instruction RAM locations
252	SAR ADC buffer mode read data

6.2 Control Registers, Page 0 (Default Page): Clock Multipliers, Dividers, Serial Interfaces, Flags, Interrupts, and GPIOs

Page 0/Register 0: Page Control Register

BIT	READ/ WRITE	RESET VALUE	DESCRIPTION
D7–D0	R/W	0000 0000	0000 0000: Page 0 selected 0000 0001: Page 1 selected ... 1111 1110: Page 254 selected 1111 1111: Page 255 selected

Page 0/Register 1: Software Reset

BIT	READ/ WRITE	RESET VALUE	DESCRIPTION
D7–D1	R/W	0000 000	Reserved. Write only zeros to these bits.
D0	R/W	0	0: Don't care 1: Self-clearing software reset for control register

Page 0/Register 2: Reserved

BIT	READ/ WRITE	RESET VALUE	DESCRIPTION
D7–D0	R	XXXXXXXX	Reserved. Do not write to this register.

Page 0/Register 3: OT FLAG

BIT	READ/ WRITE	RESET VALUE	DESCRIPTION
D7-D2	R	XXXX	Reserved. Do not write to these bits.
D1	R	1	0: Overtemperature protection flag (active-low). Valid only if speaker amplifier is powered up 1: Normal operation
D0	R/W	XX	Reserved. Do not write to these bits.

Page 0/Register 4: Clock-Gen Muxing⁽¹⁾

BIT	READ/ WRITE	RESET VALUE	DESCRIPTION
D7–D4	R/W	0000	Reserved. Write only zeros to these bits.
D3–D2	R/W	00	00: PLL_CLKIN = MCLK (device pin) 01: PLL_CLKIN = BCLK (device pin) 10: PLL_CLKIN = GPIO1 (device pin) 11: PLL_CLKIN = SDIN (can be used for the system where DAC is not used)
D1–D0	R/W	00	00: CODEC_CLKIN = MCLK (device pin) 01: CODEC_CLKIN = BCLK (device pin) 10: CODEC_CLKIN = GPIO1 (device pin) 11: CODEC_CLKIN = PLL_CLK (generated on-chip)

(1) See [Section 5.8](#) for more details on clock generation multiplexing and dividers.

Page 0/Register 5: PLL P and R-VAL

BIT	READ/ WRITE	RESET VALUE	DESCRIPTION
D7	R/W	0	0: PLL is powered down. 1: PLL is powered up.
D6–D4	R/W	001	000: PLL divider P = 8 001: PLL divider P = 1 010: PLL divider P = 2 ... 110: PLL divider P = 6 111: PLL divider P = 7
D3–D0	R/W	0001	0000: PLL multiplier R = 16 0001: PLL multiplier R = 1 0010: PLL multiplier R = 2 ... 1110: PLL multiplier R = 14 1111: PLL multiplier R = 15

Page 0/Register 6: PLL J-VAL

BIT	READ/ WRITE	RESET VALUE	DESCRIPTION
D7–D6	R/W	00	Reserved. Write only zeros to these bits.
D5–D0	R/W	00 0100	00 0000: Do not use (reserved) 00 0001: PLL multiplier J = 1 00 0010: PLL multiplier J = 2 ... 11 1110: PLL multiplier J = 62 11 1111: PLL multiplier J = 63

Table 6-2. Page 0/Register 7: PLL D-VAL MSB⁽¹⁾

BIT	READ/ WRITE	RESET VALUE	DESCRIPTION
D7–D6	R/W	00	Reserved. Write only zeros to these bits.
D5–D0	R/W	00 0000	PLL fractional multiplier D-Val MSB bits D[13:8]

(1) Note that this register will be updated only when page 0/register 8 is written immediately after page 0/register 7.

Page 0/Register 8: PLL D-VAL LSB⁽¹⁾

BIT	READ/ WRITE	RESET VALUE	DESCRIPTION
D7–D0	R/W	0000 0000	PLL fractional multiplier D-Val LSB bits D[7:0]

(1) Note that page 0/register 8 must be written immediately after page 0/register 7.

Page 0/Registers 9–10: Reserved

BIT	READ/ WRITE	RESET VALUE	DESCRIPTION
D7–D0	R/W	XXXX XXXX	Reserved. Write only zeros to these bits.

Page 0/Register 11: DAC NDAC_VAL

BIT	READ/ WRITE	RESET VALUE	DESCRIPTION
D7	R/W	0	0: DAC NDAC divider is powered down. 1: DAC NDAC divider is powered up.
D6–D0	R/W	000 0001	000 0000: DAC NDAC divider = 128 000 0001: DAC NDAC divider = 1 000 0010: DAC NDAC divider = 2 ... 111 1110: DAC NDAC divider = 126 111 1111: DAC NDAC divider = 127

Page 0/Register 12: DAC MDAC_VAL

BIT	READ/ WRITE	RESET VALUE	DESCRIPTION
D7	R/W	0	0: DAC MDAC divider is powered down. 1: DAC MDAC divider is powered up.
D6–D0	R/W	000 0001	000 0000: DAC MDAC divider = 128 000 0001: DAC MDAC divider = 1 000 0010: DAC MDAC divider = 2 ... 111 1110: DAC MDAC divider = 126 111 1111: DAC MDAC divider = 127

Page 0/Register 13: DAC DOSR_VAL MSB

BIT	READ/ WRITE	RESET VALUE	DESCRIPTION
D7–D2	R/W	0000 00	Reserved
D1–D0	R/W	00	DAC OSR value DOSR(9:8)

Page 0/Register 14: DAC DOSR_VAL LSB^{(1) (2)}

BIT	READ/ WRITE	RESET VALUE	DESCRIPTION
D7–D0	R/W	1000 0000	DAC OSR Value DOSR(7:0) 0000 0000: DAC OSR(7:0) = 1024 (MSB page 0/register 13, bits D1–D0 = 00) 0000 0001: DAC OSR(7:0) = 1 (MSB page 0/register 13, bits D1–D0 = 00) 0000 0010: DAC OSR(7:0) = 2 (MSB page 0/register 13, bits D1–D0 = 00) ... 1111 1110: DAC OSR(7:0) = 1022 (MSB page 0/register 13, bits D1–D0 = 11) 1111 1111: DAC OSR(7:0) = 1023 (MSB page 0/register 13, bits D1–D0 = 11)

(1) DAC OSR should be an integral multiple of the interpolation in the DAC miniDSP engine (specified in register 16).

(2) Note that page 0/register 14 must be written to immediately after writing to page 0/register 13.

Page 0/Register 15: DAC IDAC_VAL⁽¹⁾

BIT	READ/ WRITE	RESET VALUE	DESCRIPTION
D7–D0	R/W	1000 0000	0000 0000: Number of instruction for DAC miniDSP engine, IDAC = 1024 0000 0001: Number of instruction for DAC miniDSP engine, IDAC = 4 0000 0010: Number of instruction for DAC miniDSP engine, IDAC = 8 ... 1111 1101: Number of instruction for DAC miniDSP engine, IDAC = 1012 1111 1110: Number of instruction for DAC miniDSP engine, IDAC = 1016 1111 1111: Number of instruction for DAC miniDSP engine, IDAC = 1020

(1) IDAC should be an integral multiple of the interpolation in the DAC miniDSP engine (specified in register 16).

Page 0/Register 16: DAC miniDSP Engine Interpolation

BIT	READ/ WRITE	RESET VALUE	DESCRIPTION
D7–D4	R/W	0000	Reserved. Do not write to these registers.
D3–D0	R/W	1000	0000: Interpolation ratio in DAC miniDSP engine = 16 0001: Interpolation ratio in DAC miniDSP engine = 1 0010: Interpolation ratio in DAC miniDSP engine = 2 ... 1101: Interpolation ratio in DAC miniDSP engine = 13 1110: Interpolation ratio in DAC miniDSP engine = 14 1111: Interpolation ratio in DAC miniDSP engine = 15

Page 0/Register 17: Reserved

BIT	READ/ WRITE	RESET VALUE	DESCRIPTION
D7–D0	R/W	XXXX XXXX	Reserved. Do not write to this register.

Page 0/Register 18: ADC NADC_VAL

BIT	READ/ WRITE	RESET VALUE	DESCRIPTION
D7	R/W	0	0: ADC NADC divider is powered down and ADC_DSP_CLK = DAC_DSP_CLK. 1: ADC NADC divider is powered up.
D6–D0	R/W	000 0001	000 0000: ADC NADC divider = 128 000 0001: ADC NADC divider = 1 000 0010: ADC NADC divider = 2 ... 111 1110: ADC NADC divider = 126 111 1111: ADC NADC divider = 127

Page 0/Register 19: ADC MADC_VAL

BIT	READ/ WRITE	RESET VALUE	DESCRIPTION
D7	R/W	0	0: ADC MADC divider is powered down and ADC_MOD_CLK = DAC_MOD_CLK. 1: ADC MADC divider is powered up.
D6–D0	R/W	000 0001	000 0000: ADC MADC divider = 128 000 0001: ADC MADC divider = 1 000 0010: ADC MADC divider = 2 ... 111 1110: ADC MADC divider = 126 111 1111: ADC MADC divider = 127

Page 0/Register 20: ADC AOSR_VAL⁽¹⁾

BIT	READ/ WRITE	RESET VALUE	DESCRIPTION
D7–D0	R/W	1000 0000	0000 0000: ADC OSR AOSR divider = 256 0000 0001: ADC OSR AOSR divider = 1 0000 0010: ADC OSR AOSR divider = 2 ... 1111 1110: ADC OSR AOSR divider = 254 1111 1111: ADC OSR AOSR divider = 255

(1) ADC OSR should be an integral multiple of the decimation in the ADC miniDSP engine (specified in register 22).

Page 0/Registers 21: ADC IADC_VAL⁽¹⁾

BIT	READ/ WRITE	RESET VALUE	DESCRIPTION
D7–D0	R/W	1000 0000	0000 0000: Reserved 0000 0001: Number of instruction for ADC miniDSP engine, IADC = 2 0000 0010: Number of instruction for ADC miniDSP engine, IADC = 4 ... 1011 1111: Number of instruction for ADC miniDSP engine, IADC = 382 1100 0000: Number of instruction for ADC miniDSP engine, IADC = 384 1100 0001–1111 1111: Reserved

(1) IADC should be an integral multiple of the decimation in the ADC miniDSP engine (specified in Register 22).

Page 0/Registers 22: ADC miniDSP Engine Decimation

BIT	READ/ WRITE	RESET VALUE	DESCRIPTION
D7–D4	R/W	0000	Reserved
D3–D0	R/W	0100	0000: Decimation ratio in ADC miniDSP engine = 16 0001: Decimation ratio in ADC miniDSP engine = 1 0010: Decimation ratio in ADC miniDSP engine = 2 ... 1101: Decimation ratio in ADC miniDSP engine = 13 1110: Decimation ratio in ADC miniDSP engine = 14 1111: Decimation ratio in ADC miniDSP engine = 15

Page 0/Registers 23–24: Reserved

BIT	READ/ WRITE	RESET VALUE	DESCRIPTION
D7–D0	R/W	XXXX XXXX	Reserved. Do not write to these registers.

Page 0/Registers 25: CLKOUT MUX

BIT	READ/ WRITE	RESET VALUE	DESCRIPTION
D7–D3	R/W	0000 0	Reserved
D2–D0	R/W	000	000: CDIV_CLKIN = MCLK (device pin) 001: CDIV_CLKIN = BCLK (device pin) 010: CDIV_CLKIN = SDIN (can be used for the systems where DAC is not required) 011: CDIV_CLKIN = PLL_CLK (generated on-chip) 100: CDIV_CLKIN = DAC_CLK (DAC DSP clock - generated on-chip) 101: CDIV_CLKIN = DAC_MOD_CLK (generated on-chip) 110: CDIV_CLKIN = ADC_CLK (ADC DSP clock - generated on-chip) 111: CDIV_CLKIN = ADC_MOD_CLK (generated on-chip)

Page 0/Registers 26: CLKOUT M_VAL

BIT	READ/ WRITE	RESET VALUE	DESCRIPTION
D7	R/W	0	0: CLKOUT M divider is powered down. 1: CLKOUT M divider is powered up.
D6–D0	R/W	000 0001	000 0000: CLKOUT divider M = 128 000 0001: CLKOUT divider M = 1 000 0010: CLKOUT divider M = 2 ... 111 1110: CLKOUT divider M = 126 111 1111: CLKOUT divider M = 127

Page 0/Register 27: Codec Interface Control

BIT	READ/ WRITE	RESET VALUE	DESCRIPTION
D7–D6	R/W	00	00: Codec interface = I ² S 01: Codec Interface = DSP 10: Codec interface = RJF 11: Codec interface = LJF
D5–D4	R/W	00	00: Codec interface word length = 16 bits 01: Codec interface word length = 20 bits 10: Codec interface word length = 24 bits 11: Codec interface word length = 32 bits
D3	R/W	0	0: BCLK is input. 1: BCLK is output.
D2	R/W	0	0: WCLK is input. 1: WCLK is output.
D1	R/W	0	Reserved
D0	R/W	0	Driving SDOUT to High-Impedance for the Extra BCLK Cycle When Data Is Not Being Transferred 0: Disabled 1: Enabled

Page 0/Register 28: Data-Slot Offset Programmability

BIT	READ/ WRITE	RESET VALUE	DESCRIPTION
D7–D0	R/W	0000 0000	Offset (Measured With Respect to WCLK Rising Edge in DSP Mode) 0000 0000: Offset = 0 BCLKs 0000 0001: Offset = 1 BCLK 0000 0010: Offset = 2 BCLKs ... 1111 1110: Offset = 254 BCLKs 1111 1111: Offset = 255 BCLKs

Page 0/Register 29: Codec Interface Control 2

BIT	READ/ WRITE	RESET VALUE	DESCRIPTION
D7–D6	R/W	00	Reserved
D5	R/W	0	0: SDIN-to-SDOUT loopback is disabled. 1: SDIN-to-SDOUT loopback is enabled.
D4	R/W	0	0: ADC-to-DAC loopback is disabled. 1: ADC-to-DAC loopback is enabled.
D3	R/W	0	0: BCLK is not inverted (valid for both primary and secondary BCLK). 1: BCLK is inverted (valid for both primary and secondary BCLK).
D2	R/W	0	BCLK and WCLK Active Even With Codec Powered Down (Valid for Both Primary and Secondary BCLK) 0: Disabled 1: Enabled
D1–D0	R/W	00	00: BDIV_CLKIN = DAC_CLK (DAC DSP clock - generated on-chip) 01: BDIV_CLKIN = DAC_MOD_CLK (generated on-chip) 10: BDIV_CLKIN = ADC_CLK (ADC DSP clock - generated on-chip) 11: BDIV_CLKIN = ADC_MOD_CLK (generated on-chip)

Page 0/Register 30: BCLK N_VAL

BIT	READ/ WRITE	RESET VALUE	DESCRIPTION
D7	R/W	0	0: BCLK N-divider is powered down. 1: BCLK N-divider is powered up.
D6–D0	R/W	000 0001	000 0000: BCLK divider N = 128 000 0001: BCLK divider N = 1 000 0010: BCLK divider N = 2 ... 111 1110: BCLK divider N = 126 111 1111: BCLK divider N = 127

Page 0/Register 31: Codec Secondary Interface Control 1

BIT	READ/ WRITE	RESET VALUE	DESCRIPTION
D7–D5	R/W	000	000: Secondary BCLK is obtained from GPIO1 pin. 001: Secondary BCLK is obtained from SCLK pin. 010: Secondary BCLK is obtained from MISO pin. 011: Secondary BCLK is obtained from SDO pin. 100: Secondary BCLK is obtained from GPIO2 pin. 101: Secondary BCLK is obtained from GPI1 pin. 110: Secondary BCLK is obtained from GPI2 pin. 111: Secondary BCLK is obtained from GPI3 pin.
D4–D2	R/W	000	000: Secondary WCLK is obtained from GPIO1 pin. 001: Secondary WCLK is obtained from SCLK pin. 010: Secondary WCLK is obtained from MISO pin. 011: Secondary WCLK is obtained from SDO pin. 100: Secondary WCLK is obtained from GPIO2 pin. 101: Secondary WCLK is obtained from GPI1 pin. 110: Secondary WCLK is obtained from GPI2 pin. 111: Secondary WCLK is obtained from GPI3 pin.
D1–D0	R/W	00	00: Secondary SDIN is obtained from the GPIO1 pin. 01: Secondary SDIN is obtained from the SCLK pin. 10: Secondary SDIN is obtained from the GPIO2 pin. 11: Secondary SDIN is obtained from the GPI1 pin.

Page 0/Register 32: Codec Secondary Interface Control 2

BIT	READ/ WRITE	RESET VALUE	DESCRIPTION
D7–D5	R/W	000	000: ADC_WCLK is obtained from GPIO1 pin. 001: ADC_WCLK is obtained from SCLK pin. 010: ADC_WCLK is obtained from MISO pin. 011: Reserved 100: ADC_WCLK is obtained from GPIO2 pin. 101: ADC_WCLK is obtained from GPI1 pin. 110: ADC_WCLK is obtained from GPI2 pin. 111: ADC_WCLK is obtained from GPI3 pin.
D4	R/W	0	Reserved
D3	R/W	0	0: Primary BCLK is fed to codec serial-interface and ClockGen blocks. 1: Secondary BCLK is fed to codec serial-interface and ClockGen blocks.
D2	R/W	0	0: Primary WCLK is fed to codec serial-interface block. 1: Secondary WCLK is fed to codec serial-interface block.
D1	R/W	0	0: ADC_WCLK used in the codec serial-interface block is the same as DAC_WCLK. 1: ADC_WCLK used in the codec serial-interface block = ADC_WCLK.
D0	R/W	0	0: Primary SDIN is fed to codec serial-interface block. 1: Secondary SDIN is fed to codec serial-interface block.

Page 0/Register 33: Codec Secondary Interface Control 3

BIT	READ/ WRITE	RESET VALUE	DESCRIPTION
D7	R/W	0	0: Primary BCLK output = internally generated BCLK clock 1: Primary BCLK output = secondary BCLK
D6	R/W	0	0: Secondary BCLK output = primary BCLK 1: Secondary BCLK output = internally generated BCLK clock
D5–D4	R/W	00	00: Primary WCLK output = internally generated DAC_f _S 01: Primary WCLK output = internally generated ADC_f _S clock 10: Primary WCLK output = secondary WCLK 11: Reserved
D3–D2	R/W	00	00: Secondary WCLK output = primary WCLK 01: Secondary WCLK output = internally generated DAC_f _S clock 10: Secondary WCLK output = internally generated ADC_f _S clock 11: Reserved
D1	R/W	0	0: Primary SDO = SDO from codec serial-interface block 1: Primary SDO = secondary SDIN
D0	R/W	0	0: Secondary SDO = primary SDIN 1: Secondary SDO = SDO from codec serial interface block

Page 0/Register 34: I²C Bus Condition

BIT	READ/ WRITE	RESET VALUE	DESCRIPTION
D7–D6	R/W	00	Reserved. Write only the reset value to these bits.
D5	R/W	0	0: I ² C general-call address is ignored. 1: Device accepts I ² C general-call address.
D4–D0	R/W	00000	Reserved. Write only zeros to these bits.

Page 0/Register 35: Reserved

BIT	READ/ WRITE	RESET VALUE	DESCRIPTION
D7–D0	R/W	XXXX XXXX	Reserved. Write only zeros to these bits.

Page 0/Register 36: ADC Flag Register

BIT	READ/ WRITE	RESET VALUE	DESCRIPTION
D7	R	0	0: ADC PGA applied gain ≠ programmed gain 1: ADC PGA applied gain = programmed gain
D6	R	0	0: ADC powered down 1: ADC powered up
D5 ⁽¹⁾	R	0	0: AGC not saturated 1: AGC applied gain = maximum applicable gain by AGC
D4–D0	R/W	X XXXX	Reserved. Write only zeros to these bits.

(1) Sticky flag bits. These are read-only bits. They are automatically cleared once they are read and are set only if the source trigger occurs again.

Page 0/Register 37: DAC Flag Register

BIT	READ/ WRITE	RESET VALUE	DESCRIPTION
D7	R	0	0: Left-channel DAC powered down 1: Left-channel DAC powered up
D6	R/W	X	Reserved. Write only zero to this bit.
D5	R	0	0: HPI driver powered down 1: HPL driver powered up
D4	R	0	0: Left-channel class-D driver powered down 1: Left-channel class-D driver powered up
D3	R	0	0: Right-channel DAC powered down 1: Right-channel DAC powered up
D2	R/W	X	Reserved. Write only zero to this bit.
D1	R	0	0: HPR driver powered down 1: HPR driver powered up
D0	R	0	0: Right-channel class-D driver powered down 1: Right-channel class-D driver powered up

Page 0/Register 38: DAC Flag Register

BIT	READ/ WRITE	RESET VALUE	DESCRIPTION
D7–D5	R/W	XXX	Reserved. Do not write to these bits.
D4	R	0	0: Left-channel DAC PGA applied gain ≠ programmed gain 1: Left-channel DAC PGA applied gain = programmed gain
D3–D1	R/W	XXX	Reserved. Write only zeros to these bits.
D0	R	0	0: Right-channel DAC PGA applied gain ≠ programmed gain 1: Right-channel DAC PGA applied gain = programmed gain

Page 0/Register 39: Overflow Flags

BIT	READ/ WRITE	RESET VALUE	DESCRIPTION
D7 ⁽¹⁾	R	0	Left-Channel DAC Overflow Flag 0: Overflow has not occurred. 1: Overflow has occurred.
D6 ⁽¹⁾	R	0	Right-Channel DAC Overflow Flag 0: Overflow has not occurred. 1: Overflow has occurred.
D5 ⁽¹⁾	R	0	DAC Barrel Shifter Output Overflow Flag 0: Overflow has not occurred. 1: Overflow has occurred.
D4	R/W	0	Reserved. Write only zeros to these bits.
D3 ⁽¹⁾	R	0	Delta-Sigma Mono ADC Overflow Flag 0: Overflow has not occurred. 1: Overflow has occurred.
D2	R/W	0	Reserved. Write only zero to this bit.
D1 ⁽¹⁾	R	0	ADC Barrel Shifter Output Overflow Flag 0: Overflow has not occurred. 1: Overflow has occurred.
D0	R/W	0	Reserved. Write only zero to this bit.

(1) Sticky flag blts. These are read-only bits. They are automatically cleared once they are read and are set only if the source trigger occurs again.

Page 0/Registers 40–43: Reserved

BIT	READ/ WRITE	RESET VALUE	DESCRIPTION
D7–D0	R/W	XXXX XXXX	Reserved. Write only the reset value to these bits.

Page 0/Register 44: Interrupt Flags—DAC

BIT	READ/ WRITE	RESET VALUE	DESCRIPTION
D7 ⁽¹⁾	R	0	0: No short circuit is detected at HPL/left class-D driver. 1: Short circuit is detected at HPL/left class-D driver.
D6 ⁽¹⁾	R	0	0: No short circuit is detected at HPR/right class-D driver. 1: Short circuit is detected at HPR/right class-D driver.
D5 ⁽¹⁾	R	X	0: No headset button pressed 1: Headset button pressed
D4 ⁽¹⁾	R	X	0: No headset insertion/removal is detected. 1: Headset insertion/removal is detected.
D3 ⁽¹⁾	R	0	0: Left DAC signal power is less than or equal to the signal threshold of DRC. 1: Left DAC signal power is above the signal threshold of DRC.
D2 ⁽¹⁾	R	0	0: Right DAC signal power is less than or equal to the signal threshold of DRC. 1: Right DAC signal power is above the signal threshold of DRC.
D1 ⁽¹⁾	R	0	DAC miniDSP Engine Standard Interrupt-Port Output 0: Read a 0 from Standard Interrupt-Port 1: Read a 1 from Standard Interrupt-Port
D0 ⁽¹⁾	R	0	DAC miniDSP Engine Auxilliary Interrupt-Port Output 0: Read a 0 from Auxilliary Interrupt-Port 1: Read a 1 from Auxilliary Interrupt-Port

(1) Sticky flag blts. These are read-only bits. They are automatically cleared once they are read and are set only if the source trigger occurs again.

Page 0/Register 45: Interrupt Flags—ADC

BIT	READ/ WRITE	RESET VALUE	DESCRIPTION
D7	R/W	0	Reserved. Write only zero to this bit.
D6 ⁽¹⁾	R	0	0: ADC signal power greater than noise threshold for AGC. 1: ADC signal power less than noise threshold for AGC.
D5	R/W	0	Reserved. Write only zeros to these bits.
D4 ⁽¹⁾	R	X	ADC miniDSP Engine Standard Interrupt Port Output 0: Read a 0 from Standard Interrupt-Port 1: Raed a 1 from Standard Interrupt-Port
D3 ⁽¹⁾	R	X	ADC miniDSP Engine Auxiliary Interrupt Port Output 0: Read a 0 from Auxilliary Interrupt-Port 1: Read a 1 from Auxilliary Interrupt-Port
D2	R	0	0: DC measurement using Delta Sigma Audio ADC is not available 1: DC measurement using Delta Sigma Audio ADC is not available
D1–D0	R/W	00	Reserved. Write only zeros to these bits.

(1) Sticky flag blts. These are read-only bits. They are automatically cleared once they are read and are set only if the source trigger occurs again.

Page 0/Register 46: Interrupt Flags – DAC

BIT	READ/ WRITE	RESET VALUE	DESCRIPTION
D7	R	0	0: No short circuit detected at HPL/left class-D driver 1: Short circuit detected at HPL/left class-D driver
D6	R	0	0: No short circuit detected at HPR/right class-D driver 1: Short circuit detected at HPR/right class-D driver
D5	R	X	0: No headset button pressed 1: Headset button pressed
D4	R	X	0: Headset removal detected 1: Headset insertion detected
D3	R	0	0: Left DAC signal power is below signal threshold of DRC. 1: Left DAC signal power is above signal threshold of DRC.
D2	R	0	0: Right DAC signal power is below signal threshold of DRC. 1: Right DAC signal power is above signal threshold of DRC.
D1	R	0	DAC miniDSP Engine Standard Interrupt Port Output 0: Read a 0 from Standard Interrupt-Port 1: Raed a 1 from Standard Interrupt-Port
D0	R	0	DAC miniDSP Engine Auxiliary Interrupt Port Output 0: Read a 0 from Auxilliary Interrupt-Port 1: Read a 1 from Auxilliary Interrupt-Port

Page 0/Register 47: Interrupt Flags – ADC

BIT	READ/ WRITE	RESET VALUE	DESCRIPTION
D7	R/W	0	Reserved
D6	R	0	0: Delta-sigma mono ADC signal power greater than noise threshold for left AGC 1: Delta-sigma mono ADC signal power less than noise threshold for left AGC
D5	R/W	0	Reserved
D4	R	X	ADC miniDSP Engine Standard Interrupt Port Output 0: Read a 0 from Standard Interrupt-Port 1: Raed a 1 from Standard Interrupt-Port
D3	R	X	ADC miniDSP Engine Auxiliary Interrupt Port Output 0: Read a 0 from Auxilliary Interrupt-Port 1: Read a 1 from Auxilliary Interrupt-Port
D2	R	0	0: DC measurement using Delta Sigma Audio ADC is not available 1: DC measurement using Delta Sigma Audio ADC is not available
D1–D0	R/W	00	Reserved. Write only zeros to these bits.

Page 0/Register 48: INT1 Control Register

BIT	READ/ WRITE	RESET VALUE	DESCRIPTION
D7	R/W	0	0: Headset-insertion detect interrupt is not used in the generation of INT1 interrupt. 1: Headset-insertion detect interrupt is used in the generation of INT1 interrupt.
D6	R/W	0	0: Button-press detect interrupt is not used in the generation of INT1 interrupt. 1: Button-press detect interrupt is used in the generation of INT1 interrupt.
D5	R/W	0	0: DAC DRC signal-power interrupt is not used in the generation of INT1 interrupt. 1: DAC DRC signal-power interrupt is used in the generation of INT1 interrupt.
D4	R/W	0	0: ADC AGC noise interrupt is not used in the generation of INT1 interrupt. 1: ADC AGC noise interrupt is used in the generation of INT1 interrupt.
D3	R/W	0	0: Short-circuit interrupt is not used in the generation of INT1 interrupt. 1: Short-circuit interrupt is used in the generation of INT1 interrupt.
D2	R/W	0	0: Engine-generated interrupt is not used in the generation of INT1 interrupt. 1: Engine-generated interrupt is used in the generation of INT1 interrupt.
D1	R/W	0	0: DC measurement using Delta Sigma Audio ADC data-available interrupt is not used in the generation of INT1 interrupt 1: DC measurement using Delta Sigma Audio ADC data-available interrupt is used in the generation of INT1 interrupt
D0	R/W	0	0: INT1 is only one pulse (active-high) of typical 2-ms duration. 1: INT1 is multiple pulses (active-high) of typical 2-ms duration and 4-ms period, until flag registers 44, 45, and 50 are read by the user.

Page 0/Register 49: INT2 Control Register

BIT	READ/ WRITE	RESET VALUE	DESCRIPTION
D7	R/W	0	0: Headset-insertion detect interrupt is not used in the generation of INT2 interrupt. 1: Headset-insertion detect interrupt is used in the generation of INT2 interrupt.
D6	R/W	0	0: Button-press detect interrupt is not used in the generation of INT2 interrupt. 1: Button-press detect interrupt is used in the generation of INT2 interrupt.
D5	R/W	0	0: DAC DRC signal-power interrupt is not used in the generation of INT2 interrupt. 1: DAC DRC signal-power interrupt is used in the generation of INT2 interrupt.
D4	R/W	0	0: ADC AGC noise interrupt is not used in the generation of INT2 interrupt. 1: ADC AGC noise interrupt is used in the generation of INT2 interrupt.
D3	R/W	0	0: Short-circuit interrupt is not used in the generation of INT2 interrupt. 1: Short-circuit interrupt is used in the generation of INT2 interrupt.
D2	R/W	0	0: Engine-generated interrupt is not used in the generation of INT2 interrupt. 1: Engine-generated interrupt is used in the generation of INT2 interrupt.
D1	R/W	0	0: DC measurement using Delta Sigma Audio ADC data-available interrupt is not used in the generation of INT2 interrupt 1: DC measurement using Delta Sigma Audio ADC data-available interrupt is used in the generation of INT2 interrupt
D0	R/W	0	0: INT2 is only one pulse (active-high) of typical 2-ms duration. 1: INT2 is multiple pulses (active-high) of typical 2-ms duration and 4-ms period, until flag registers 44, 45, and 50 are read by the user.

Page 0/Register 50: INT1 and INT2 Control Register

BIT	READ/ WRITE	RESET VALUE	DESCRIPTION
D7	R/W	0	0: SAR measurement data-out-of-threshold range interrupt is not used in the generation of the INT1 interrupt. 1: SAR measurement data-out-of-threshold range interrupt is not used in the generation of the INT1 interrupt.
D6	R/W	0	0: Pen touch/SAR data-available interrupt is not used in the generation of the INT1 interrupt. 1: Pen touch/SAR data-available interrupt is used in the generation of the INT1 interrupt.
D5	R/W	0	0: SAR measurement data-out-of-threshold range interrupt is not used in the generation of the INT2 interrupt. 1: SAR measurement data-out-of-threshold range interrupt is not used in the generation of the INT2 interrupt.
D4	R/W	0	Reserved
D3	R	0	0: No pen touch detected 1: Pen touch detected
D2	R	0	0: No data available for read 1: Data available for read
D1	R	0	0: SAR data is within threshold program. 1: SAR data is out of programmed threshold range.
D0	R	0	Reserved. Write only the default value to this bit.

Page 0/Register 51: GPIO1 In/Out Pin Control

BIT	READ/ WRITE	RESET VALUE	DESCRIPTION
D7–D6	R/W	XX	Reserved. Do not write any value other than reset value.
D5–D2	R/W	0000	0000: GPIO1 disabled (input and output buffers powered down) 0001: GPIO1 is in input mode (can be used as secondary BCLK input, secondary WCLK input, secondary SDIN input, ADC_WCLK input, Dig_Mic_In or in ClockGen block). 0010: GPIO1 is used as general-purpose input (GPI). 0011: GPIO1 output = general-purpose output 0100: GPIO1 output = CLKOUT output 0101: GPIO1 output = INT1 output 0110: GPIO1 output = INT2 output 0111: GPIO1 output = ADC_WCLK output for codec interface 1000: GPIO1 output = secondary BCLK output for codec interface 1001: GPIO1 output = secondary WCLK output for codec interface 1010: GPIO1 output = ADC_MOD_CLK output for the digital microphone 1011: GPIO1 output = secondary SDOUT for codec interface 1100: GPIO1 output = TouchScreen/SAR ADC interrupt (active-low) as $\overline{\text{PINTDAV}}$ signal 1101: Reserved 1110: Reserved 1111: Reserved
D1	R	X	GPIO1 input buffer value
D0	R/W	0	0: GPIO1 general-purpose output value = 0 1: GPIO1 general-purpose output value = 1

Page 0/Register 52: GPIO2 In/Out Pin Control

BIT	READ/ WRITE	RESET VALUE	DESCRIPTION
D7–D6	R/W	XX	Reserved. Do not write any value other than reset value.
D5–D2	R/W	0000	0000: GPIO2 disabled (input and output buffers powered down) 0001: GPIO2 is in input mode (can be used as secondary BCLK input, secondary WCLK input, secondary SDIN input, ADC_WCLK input, Dig_Mic_In or in ClockGen block). 0010: GPIO2 is used as general-purpose input (GPI). 0011: GPIO2 output = general-purpose output 0100: GPIO2 output = CLKOUT output 0101: GPIO2 output = INT1 output 0110: GPIO2 output = INT2 output 0111: GPIO2 output = ADC_WCLK output for codec interface 1000: GPIO2 output = secondary BCLK output for codec interface 1001: GPIO2 output = secondary WCLK output for codec interface 1010: GPIO2 output = ADC_MOD_CLK output for the digital microphone 1011: GPIO2 output = secondary SDOUT for codec interface 1100: GPIO2 output = TouchScreen/SAR ADC interrupt (active-low) as $\overline{\text{PINTDAV}}$ signal 1101: Reserved 1110: Reserved 1111: Reserved
D1	R	X	GPIO2 input buffer value
D0	R/W	0	0: GPIO2 general-purpose output value = 0 1: GPIO2 general-purpose output value = 1

Page 0/Register 53: SDOUT (OUT Pin) Control

BIT	READ/ WRITE	RESET VALUE	DESCRIPTION
D7–D5	R/W	000	Reserved
D4	R/W	1	0: SDOUT bus keeper enabled 1: SDOUT bus keeper disabled
D3–D1	R/W	001	000: SDOUT disabled (output buffer powered down) 001: SDOUT = primary SDOUT output for codec interface 010: SDOUT = general-purpose output 011: SDOUT = CLKOUT output 100: SDOUT = INT1 output 101: SDOUT = INT2 output 110: SDOUT = secondary BCLK output for codec interface 111: SDOUT = secondary WCLK output for codec interface
D0	R/W	0	0: SDOUT general-purpose output value = 0 1: SDOUT general-purpose output value = 1

Page 0/Register 54: SDIN (IN Pin) Control

BIT	READ/ WRITE	RESET VALUE	DESCRIPTION
D7–D3	R/W	0000 0	Reserved
D2–D1	R/W	01	00: SDIN disabled (input buffer powered down) 01: SDIN enabled (can be used as SDIN for codec interface, Dig_Mic_In or in ClockGen block) 10: SDIN is used as general-purpose input (GPI) 11: Reserved
D0	R	X	SDIN input-buffer value

Page 0/Register 55: MISO (OUT Pin) Control

BIT	READ/ WRITE	RESET VALUE	DESCRIPTION
D7–D5	R/W	000	Reserved
D4–D1	R/W	0001	0000: MISO disabled (output buffer powered down) 0001: MISO = MISO output for SPI interface or disabled in case of I ² C interface 0010: General-purpose output 0011: MISO = CLKOUT output 0100: MISO = INT1 output 0101: MISO = INT2 output 0110: MISO = ADC_WCLK output for codec interface 0111: MISO = ADC_MOD_CLK output for the digital microphone 1000: MISO = secondary SDOOUT for codec interface 1001: MISO = secondary BCLK output for codec interface 1010: MISO = secondary WCLK output for codec interface 1011–1111: Reserved
D0	R/W	0	0: MISO general-purpose output value = 0 1: MISO general-purpose output value = 1

Page 0/Register 56: SCLK (IN Pin) Control

BIT	READ/ WRITE	RESET VALUE	DESCRIPTION
D7–D3	R/W	0000 0	Reserved
D2–D1	R/W	01	00: SCLK disabled (input buffer powered down) 01: SCLK enabled and used for the SPI interface 10: SCLK enabled and is used a general-purpose input (GPI) 11: SCLK enabled and can be used as secondary SDIN, secondary BCLK input, secondary WCLK input, ADC_WCLK Input, or Dig_Mic_In
D0	R	X	SCLK input buffer value

Page 0/Register 57: GPI1 and GPI2 Pin Control

BIT	READ/ WRITE	RESET VALUE	DESCRIPTION
D7	R/W	0	Reserved. Write only zero to this bit.
D6–D5	R/W	00	00: GPI1 disabled (input buffer powered down) 01: GPI1 enabled (this pin can be used as secondary SDIN, secondary BCLK input, secondary WCLK input, ADC_WCLK input) 10: GPI1 is enabled and used as a general-purpose input (GPI). 11: Reserved
D4	R	X	GPI1 pin value
D3	R/W	0	Reserved. Write only zero to this bit.
D2–D1	R/W	00	00: GPI2 disabled (input buffer powered down) 01: GPI2 enabled (this pin can be used as secondary BCLK input, secondary WCLK input, ADC_WCLK input) 10: GPI2 is enabled and used as a general-purpose input (GPI). 11: GPI2 is enabled and used as an HP_SP input.
D0	R	X	GPI2 pin value

Page 0/Register 58: GPI3 Pin Control

BIT	READ/ WRITE	RESET VALUE	DESCRIPTION
D7	R/W	0	Reserved. Write only zero to this bit.
D6–D5	R/W	00	00: GPI3 disabled (input buffer powered down) 01: GPI3 enabled (this pin can be used as secondary BCLK input, secondary WCLK input, ADC_WCLK input) 10: GPI3 is enabled and used as a general purpose input (GPI). 11: Reserved
D4	R	X	GPI3 pin value.
D3–D0	R/W	0000	Reserved. Write only zeros to these bits.

Page 0/Register 59: Reserved

BIT	READ/ WRITE	RESET VALUE	DESCRIPTION
D7–D0	R/W	XXXX XXXX	Reserved. Write only zeros to these bits.

Page 0/Register 60: DAC Instruction Set

BIT	READ/ WRITE	RESET VALUE	DESCRIPTION
D7–D5	R/W	000	Reserved. Write only default value.
D4–D0	R/W	00 0001	0 0000: miniDSP is used for signal processing 0 0001: DAC Signal Processing Block PRB_P1 0 0010: DAC Signal Processing Block PRB_P2 0 0011: DAC Signal Processing Block PRB_P3 0 0100: DAC Signal Processing Block PRB_P4 ... 1 1000: DAC Signal Processing Block PRB_P24 1 1001: DAC Signal Processing Block PRB_P25 1 1010–1 1111: Reserved. Do not use.

Page 0/Register 61: ADC Instruction Set

BIT	READ/ WRITE	RESET VALUE	DESCRIPTION
D7–D5	R/W	000	Reserved. Write only default values.
D4–D0	R/W	0 0100	0 0000: ADC miniDSP is used for signal processing 0 0001–0 0011: Reserved 0 0100: ADC Signal Processing Block PRB_R4 0 0101: ADC Signal Processing Block PRB_R5 0 0110: ADC Signal Processing Block PRB_R6 0 0111–01001: Reserved 0 1010: ADC Signal Processing Block PRB_R10 0 1011: ADC Signal Processing Block PRB_R11 0 1100: ADC Signal Processing Block PRB_R12 0 1101–0 1111: Reserved 1 0000: ADC Signal Processing Block PRB_R16 1 0001: ADC Signal Processing Block PRB_R17 1 0010: ADC Signal Processing Block PRB_R18 1 0011–1 1111: Reserved. Do not write these sequences to these bits.

Page 0/Register 62: Programmable Instruction Mode-Control Bits

BIT	READ/ WRITE	RESET VALUE	DESCRIPTION
D7	R/W	0	Reserved
D6	R/W	0	ADC miniDSP Engine Auxilliary Control bit A, Which Can Be Used for Conditional Instructions Like JMP
D5	R/W	0	ADC miniDSP Engine Auxilliary Control bit B, Which Can Be Used for Conditional Instructions Like JMP
D4	R/W	0	0: Reset ADC miniDSP instruction counter at the start of the new frame. 1: Do not reset ADC miniDSP instruction counter at the start of the new frame.
D3	R/W	0	Reserved
D2	R/W	0	DAC miniDSP Engine Auxilliary Control bit A, Which Can Be Used for Conditional Instructions Like JMP
D1	R/W	0	DAC miniDSP Engine Auxilliary Control bit B, Which Can Be Used for Conditional Instructions Like JMP
D0	R/W	0	0: Reset DAC miniDSP instruction counter at the start of the new frame. 1: Do not reset DAC miniDSP instruction counter at the start of the new frame.

Page 0/Register 63: DAC Data-Path Setup

BIT	READ/ WRITE	RESET VALUE	DESCRIPTION
D7	R/W	0	0: Left-channel DAC is powered down. 1: Left-channel DAC is powered up.
D6	R/W	0	0: Right-channel DAC is powered down. 1: Right-channel DAC is powered up.
D5–D4	R/W	01	00: Left-channel DAC data path = off 01: Left-channel DAC data path = left data 10: Left-channel DAC data path = right data 11: Left-channel DAC data path = left-channel and right-channel data ((L + R)/2)
D3–D2	R/W	01	00: Right-channel DAC data path = off 01: Right-channel DAC data path = right data 10: Right-channel DAC data path = left data 11: Right-channel DAC data path = left-channel and right-channel data ((L + R)/2)
D1–D0	R/W	00	00: DAC channel volume control soft-stepping is enabled for one step per sample period. 01: DAC channel volume control soft-stepping is enabled for one step per two sample periods. 10: DAC channel volume control soft-stepping is disabled. 11: Reserved. Do not write this sequence to these bits.

Page 0/Register 64: DAC VOLUME CONTROL

BIT	READ/ WRITE	RESET VALUE	DESCRIPTION
D7–D4	R/W	0000	Reserved. Write only zeros to these bits.
D3	R/W	1	0: Left-channel DAC not muted 1: Left-channel DAC muted
D2	R/W	1	0: Right-channel DAC not muted 1: Right-channel DAC muted
D1–D0	R/W	00	00: Left and right channels have independent volume control. ⁽¹⁾ 01: Left-channel volume control is the programmed value of right-channel volume control. 10: Right-channel volume control is the programmed value of left-channel volume control. 11: Same as 00

(1) When DRC is enabled, left and right channels volume controls are always independent. Program bits D1-D0 to 00.

Page 0/Register 65: DAC Left Volume Control

BIT	READ/ WRITE	RESET VALUE	DESCRIPTION
D7–D0	R/W	0000 0000	127 to 49: Reserved. Do not write these sequences to these bits. 48: Left-channel DAC digital gain = 24 dB 47: Left-channel DAC digital gain = 23.5 dB 46: Left-channel DAC digital gain = 23 dB ... 36: Left-channel DAC digital gain = 18 dB 35: Left-channel DAC digital gain = 17.5 dB 34: Left-channel DAC digital gain = 17 dB ... 1: Left-channel DAC digital gain = 0.5 dB 0: Left-channel DAC digital gain = 0 dB –1: Left-channel DAC digital gain = –0.5 dB ... –126: Left-channel DAC digital gain = –63 dB –127: Left-channel DAC digital gain = –63.5 dB –128: Reserved

Page 0/Register 66: DAC Right Volume Control

BIT	READ/ WRITE	RESET VALUE	DESCRIPTION
D7–D0	R/W	0000 0000	127 to 49: Reserved. Do not write these sequences to these bits. 48: Right-channel DAC digital gain = 24 dB 47: Right-channel DAC digital gain = 23.5 dB 46: Right-channel DAC digital gain = 23 dB ... 36: Right-channel DAC digital gain = 18 dB 35: Right-channel DAC digital gain = 17.5 dB 34: Right-channel DAC digital gain = 17 dB ... 1: Right-channel DAC digital gain = 0.5 dB 0: Right-channel DAC digital gain = 0 dB –1: Right-channel DAC digital gain = –0.5 dB ... –126: Right-channel DAC digital gain = –63 dB –127: Right-channel DAC digital gain = –63.5 dB –128: Reserved

Page 0/Register 67: Headset Detection

BIT	READ/ WRITE	RESET VALUE	DESCRIPTION
D7	R/W	0	0: Headset detection disabled 1: Headset detection enabled
D6–D5	R	XX	00: No headset detected 01: Headset without microphone is detected 10: Reserved 11: Headset with microphone is detected
D4–D2	R/W	000	Debounce Programming for Glitch Rejection During Headset Detection ⁽¹⁾ 000: 16 ms (sampled with 2-ms clock) 001: 32 ms (sampled with 4-ms clock) 010: 64 ms (sampled with 8-ms clock) 011: 128 ms (sampled with 16-ms clock) 100: 256 ms (sampled with 32-ms clock) 101: 512 ms (sampled with 64-ms clock) 110: Reserved 111: Reserved
D1–D0	R/W	00	Debounce Programming for Glitch Rejection During Headset Button-Press Detection 00: 0 ms 01: 8 ms (sampled with 1-ms clock) 10: 16 ms (sampled with 2-ms clock) 11: 32 ms (sampled with 4-ms clock)

(1) Note that these times are generated using the 1 MHz reference clock which is defined in page 3/register 16.

Page 0/Register 68: DRC Control 1

BIT	READ/ WRITE	RESET VALUE	DESCRIPTION
D7	R/W	0	Reserved. Write only the reset value to these bits.
D6	R/W	0	0: DRC disabled for left channel 1: DRC enabled for left channel
D5	R/W	0	0: DRC disabled for right channel 1: DRC enabled for right channel
D4–D2	R/W	011	000: DRC threshold = –3 dB 001: DRC threshold = –6 dB 010: DRC threshold = –9 dB 011: DRC threshold = –12 dB 100: DRC threshold = –15 dB 101: DRC threshold = –18 dB 110: DRC threshold = –21 dB 111: DRC threshold = –24 dB
D1–D0	R/W	11	00: DRC hysteresis = 0 dB 01: DRC hysteresis = 1 dB 10: DRC hysteresis = 2 dB 11: DRC hysteresis = 3 dB

Page 0/Register 69: DRC Control 2

BIT	READ/ WRITE	RESET VALUE	DESCRIPTION
D	R	0	Reserved. Write only the reset value to these bits.
D6–D3	R/W	0111	DRC Hold Programmability 0000: DRC Hold Disabled 0001: DRC Hold Time = 32 DAC Word Clocks 0010: DRC Hold Time = 64 DAC Word Clocks 0011: DRC Hold Time = 128 DAC Word Clocks 0100: DRC Hold Time = 256 DAC Word Clocks 0101: DRC Hold Time = 512 DAC Word Clocks ... 1110: DRC Hold Time = 4*32768 DAC Word Clocks 1111: DRC Hold Time = 5*32768 DAC Word Clocks
D2–D0		000	Reserved. Write only the reset value to these bits.

Page 0/Register 70: DRC Control 3

BIT	READ/ WRITE	RESET VALUE	DESCRIPTION
D7–D4	R/W	0000	0000: DRC attack rate = 4 dB per DAC Word Clock 0001: DRC attack rate = 2 dB per DAC Word Clock 0010: DRC attack rate = 1 dB per DAC Word Clock ... 1110: DRC attack rate = 2.4414e–5 dB per DAC Word Clock 1111: DRC attack rate = 1.2207e–5 dB per DAC Word Clock
D3–D0	R/W	0000	0000: DRC decay rate = 1.5625e–2 dB per DAC Word Clock 0001: DRC decay rate = 7.8125e–3 dB per DAC Word Clock 0010: DRC decay rate = 3.9062e–3 dB per DAC Word Clock ... 1110: DRC decay rate = 9.5367e–7 dB per DAC Word Clock 1111: DRC decay rate = 4.7683e–7 dB per DAC Word Clock

Page 0/Register 71: Left Beep Generator ⁽¹⁾

BIT	READ/ WRITE	RESET VALUE	DESCRIPTION
D7	R/W	0	0: Beep generator is disabled. 1: Beep generator is enabled (self-clearing based on beep duration).
D6	R/W	0	0: Auto beep generator on pen touch is disabled. 1: Auto beep generator on pen touch is enabled (CODEC_CLKIN should be available for this and is used whenever touch is detected).
D5–D0	R/W	00 0000	00 0000: Left-channel beep volume control = 2 dB 00 0001: Left-channel beep volume control = 1 dB 00 0010: Left-channel beep volume control = 0 dB 00 0011: Left-channel beep volume control = –1 dB ... 11 1110: Left-channel beep volume control = –60 dB 11 1111: Left-channel beep volume control = –61 dB

(1) The beep generator is only available in PRB_P25 DAC processing mode.

Page 0/Register 72: Right Beep Generator ⁽¹⁾

BIT	READ/ WRITE	RESET VALUE	DESCRIPTION
D7–D6	R/W	00	00: Left and right channels have independent beep volume control. 01: Left-channel beep volume control is the programmed value of right-channel beep volume control. 10: Right-channel beep volume control is the programmed value of left-channel beep volume control. 11: Same as 00
D5–D0	R/W	00 0000	00 0000: Right-channel beep volume control = 2 dB 00 0001: Right-channel beep volume control = 1 dB 00 0010: Right-channel beep volume control = 0 dB 00 0011: Right-channel beep volume control = –1 dB ... 11 1110: Right-channel beep volume control = –60 dB 11 1111: Right-channel beep volume control = –61 dB

(1) The beep generator is only available in PRB_P25 DAC processing mode.

Page 0/Register 73: Beep Length MSB

BIT	READ/ WRITE	RESET VALUE	DESCRIPTION
D7–D0	R/W	0000 0000	8 MSBs out of 24 bits for the number of samples for which the beep must be generated.

Page 0/Register 74: Beep Length Middle Bits

BIT	READ/ WRITE	RESET VALUE	DESCRIPTION
D7–D0	R/W	0000 0000	8 middle bits out of 24 bits for the number of samples for which the beep must be generated.

Page 0/Register 75: Beep Length LSB

BIT	READ/ WRITE	RESET VALUE	DESCRIPTION
D7–D0	R/W	1110 1110	8 LSBs out of 24 bits for the number of samples for which beep need to be generated.

Page 0/Register 76: Beep Sin(x) MSB

BIT	READ/ WRITE	RESET VALUE	DESCRIPTION
D7–D0	R/W	0001 0000	8 MSBs out of 16 bits for $\sin(2\pi \times f_{in}/f_s)$, where f_{in} is the beep frequency and f_s is the DAC sample rate.

Page 0/Register 77: Beep Sin(x) LSB

BIT	READ/ WRITE	RESET VALUE	DESCRIPTION
D7–D0	R/W	1101 1000	8 LSBs out of 16 bits for $\sin(2\pi \times f_{in}/f_s)$, where f_{in} is the beep frequency and f_s is the DAC sample rate.

Page 0/Register 78: Beep Cos(x) MSB

BIT	READ/ WRITE	RESET VALUE	DESCRIPTION
D7–D0	R/W	0111 1110	8 MSBs out of 16 bits for $\cos(2\pi \times f_{in}/f_s)$, where f_{in} is the beep frequency and f_s is the DAC sample rate.

Page 0/Register 79: Beep Cos(x) LSB

BIT	READ/ WRITE	RESET VALUE	DESCRIPTION
D7–D0	R/W	1110 0011	8 LSBs out of 16 bits for $\cos(2\pi \times f_{in}/f_s)$, where f_{in} is the beep frequency and f_s is the DAC sample rate.

Page 0/Register 80: Reserved

BIT	READ/ WRITE	RESET VALUE	DESCRIPTION
D7–D0	R/W	XXXX XXXX	Reserved. Write only the reset value to these bits.

Page 0/Register 81: ADC Digital Mic

BIT	READ/ WRITE	RESET VALUE	DESCRIPTION
D7	R/W	0	0: ADC channel is powered down. 1: ADC channel is powered up.
D6	R/W	0	Reserved
D5–D4	R/W	00	00: Digital microphone input is obtained from GPIO1 pin. 01: Digital microphone input is obtained from SCLK pin. 10: Digital microphone input is obtained from SDIN pin. 11: Digital microphone input is obtained from GPIO2 pin.
D3	R/W	0	0: Digital microphone is not enabled for delta-sigma mono ADC channel. 1: Digital microphone is enabled for delta-sigma mono ADC channel
D2	R/W	0	Reserved
D1–D0	R/W	00	00: ADC channel volume control soft-stepping is enabled for one step per sample period. 01: ADC channel volume control soft-stepping is enabled for one step per two sample periods. 10: ADC channel volume control soft-stepping is disabled. 11: Reserved. Do not write this sequence to these bits.

Page 0/Register 82: ADC Digital Volume Control Fine Adjust

BIT	READ/ WRITE	RESET VALUE	DESCRIPTION
D7	R/W	1	0: ADC channel not muted 1: ADC channel muted
D6–D4	R/W	000	Delta-Sigma Mono ADC Channel Volume Control Fine Gain 000: 0 dB 001: –0.1 dB 010: –0.2 dB 011: –0.3 dB 100: –0.4 dB 101–111: Reserved
D3–D0	R/W	0000	Reserved. Write only zeros to these bits.

Page 0/Register 83: ADC Digital Volume Control Coarse Adjust

BIT	READ/ WRITE	RESET VALUE	DESCRIPTION
D7	R/W	0	Reserved
D6–D0		000 0000	100 0000–110 0111: Reserved 110 1000: –12 dB 110 1001: –11.5 dB ... 111 1111: –0.5 dB 000 0000: 0 dB 000 0001: 0.5 dB ... 010 0111: 19.5 dB 010 1000: 20 dB 010 1001–011 1111: Reserved

Page 0/Registers 84–85: Reserved

BIT	READ/ WRITE	RESET VALUE	DESCRIPTION
D7	R/W	XXXX XXXX	Reserved. Write only the reset value to these bits.

Page 0/Register 86: AGC Control 1

BIT	READ/ WRITE	RESET VALUE	DESCRIPTION
D7	R/W	0	0: AGC disabled 1: AGC enabled
D6–D4	R/W	000	000: AGC target level = –5.5 dB 001: AGC target level = –8 dB 010: AGC target level = –10 dB 011: AGC target level = –12 dB 100: AGC target level = –14 dB 101: AGC target level = –17 dB 110: AGC target level = –20 dB 111: AGC target level = –24 dB
D3–D0	R/W	0000	Reserved. Write only zeros to these bits.

Page 0/Register 87: AGC Control 2

BIT	READ/ WRITE	RESET VALUE	DESCRIPTION
D7–D6	R/W	00	00: AGC hysteresis setting of 1 dB 01: AGC hysteresis setting of 2 dB 10: AGC hysteresis setting of 4 dB 11: AGC hysteresis disabled
D5–D1	R/W	00 000	00 000: AGC noise/silence detection is disabled. 00 001: AGC noise threshold = –30dB 00 010: AGC noise threshold = –32dB 00 011: AGC noise threshold = –34dB ... 11 101: AGC noise threshold = –86dB 11 110: AGC noise threshold = –88dB 11 111: AGC noise threshold = –90dB
D0	R/W	0	Reserved. Write only zero to this bit.

Page 0/Register 88: AGC Maximum Gain

BIT	READ/ WRITE	RESET VALUE	DESCRIPTION
D7	R/W	0	Reserved. Write only zero to this bit.
D6–D0	R/W	111 1111	000 0000: AGC maximum gain = 0 dB 000 0001: AGC maximum gain = 0.5 dB 000 0010: AGC maximum gain = 1 dB ... 111 0011: AGC maximum gain = 57.5 dB 111 0100: AGC maximum gain = 58 dB 111 0101: AGC maximum gain = 58.5 dB 111 0110: AGC maximum gain = 59 dB 111 0111: AGC maximum gain = 59.5 dB 111 1000–111 1111: Reserved. Do not write these sequences to these bits.

Page 0/Register 89: AGC Attack Time

BIT	READ/ WRITE	RESET VALUE	DESCRIPTION
D7–D3	R/W	0000 0	0000 0: AGC attack time = $1 \times (32/f_S)$ where f_S is the ADC sample rate 0000 1: AGC attack time = $3 \times (32/f_S)$ where f_S is the ADC sample rate 0001 0: AGC attack time = $5 \times (32/f_S)$ where f_S is the ADC sample rate 0001 1: AGC attack time = $7 \times (32/f_S)$ where f_S is the ADC sample rate 0010 0: AGC attack time = $9 \times (32/f_S)$ where f_S is the ADC sample rate ... 1111 0: AGC attack time = $61 \times (32/f_S)$ where f_S is the ADC sample rate 1111 1: AGC attack time = $63 \times (32/f_S)$ where f_S is the ADC sample rate
D2–D0	R/W	000	000: Multiply factor for the programmed AGC attack time = 1 001: Multiply factor for the programmed AGC attack time = 2 010: Multiply factor for the programmed AGC attack time = 4 ... 111: Multiply factor for the programmed AGC attack time = 128

Page 0/Register 90: AGC Decay Time

BIT	READ/ WRITE	RESET VALUE	DESCRIPTION
D7–D3	R/W	0000 0	0000 0: AGC decay time = $1 \times (512/f_S)$ 0000 1: AGC decay time = $3 \times (512/f_S)$ 0001 0: AGC decay time = $5 \times (512/f_S)$ 0001 1: AGC decay time = $7 \times (512/f_S)$ 0010 0: AGC decay time = $9 \times (512/f_S)$... 1111 0: AGC decay time = $61 \times (512/f_S)$ 1111 1: AGC decay time = $63 \times (512/f_S)$
D2–D0	R/W	000	000: Multiply factor for the programmed AGC decay time = 1 001: Multiply factor for the programmed AGC decay time = 2 010: Multiply factor for the programmed AGC decay time = 4 ... 111: Multiply factor for the programmed AGC decay time = 128

Page 0/Register 91: AGC Noise Debounce

BIT	READ/ WRITE	RESET VALUE	DESCRIPTION
D7–D5	R/W	000	Reserved. Write only zeros to these bits.
D4–D0	R/W	0 0000	0 0000: AGC noise debounce = $0/f_S$ 0 0001: AGC noise debounce = $4/f_S$ 0 0010: AGC noise debounce = $8/f_S$ 0 0011: AGC noise debounce = $16/f_S$ 0 0100: AGC noise debounce = $32/f_S$ 0 0101: AGC noise debounce = $64/f_S$ 0 0110: AGC noise debounce = $128/f_S$ 0 0111: AGC noise debounce = $256/f_S$ 0 1000: AGC noise debounce = $512/f_S$ 0 1001: AGC noise debounce = $1024/f_S$ 0 1010: AGC noise debounce = $2048/f_S$ 0 1011: AGC noise debounce = $4096/f_S$ 0 1100: AGC noise debounce = $2 \times 4096/f_S$ 0 1101: AGC noise debounce = $3 \times 4096/f_S$ 0 1110: AGC noise debounce = $4 \times 4096/f_S$... 1 1110: AGC noise debounce = $20 \times 4096/f_S$ 1 1111: AGC noise debounce = $21 \times 4096/f_S$

Page0 /Register 92: AGC Signal Debounce

BIT	READ/ WRITE	RESET VALUE	DESCRIPTION
D7–D4	R/W	0000	Reserved. Write only zeros to these bits.
D3–D0	R/W	0000	0000: AGC signal debounce = $0/f_S$ 0001: AGC signal debounce = $4/f_S$ 0010: AGC signal debounce = $8/f_S$ 0011: AGC signal debounce = $16/f_S$ 0100: AGC signal debounce = $32/f_S$ 0101: AGC signal debounce = $64/f_S$ 0110: AGC signal debounce = $128/f_S$ 0111: AGC signal debounce = $256/f_S$ 1000: AGC signal debounce = $512/f_S$ 1001: AGC signal debounce = $1024/f_S$ 1010: AGC signal debounce = $2048/f_S$ 1011: AGC signal debounce = $2 \times 2048/f_S$ 1100: AGC signal debounce = $3 \times 2048/f_S$ 1101: AGC signal debounce = $4 \times 2048/f_S$ 1110: AGC signal debounce = $5 \times 2048/f_S$ 1111: AGC signal debounce = $6 \times 2048/f_S$

Page 0/Register 93: AGC Gain-Applied Reading

BIT	READ/ WRITE	RESET VALUE	DESCRIPTION
D7–D0	R	XXXX XXXX	–24: Gain applied by AGC = –12 dB –23: Gain applied by AGC = –11.5 dB ... 0: Gain applied by AGC = 0 dB ... 115: Gain applied by AGC = 57.5 dB 116: Gain applied by AGC = 58 dB 117: Gain applied by AGC = 58.5 dB 118: Gain applied by AGC = 59 dB 119: Gain applied by AGC = 59.5 dB

Page 0/Registers 94–101: Reserved

BIT	READ/ WRITE	RESET VALUE	DESCRIPTION
D7–D0	R/W	XXXX XXXX	Reserved. Do not write to these registers.

Page 0/Register 102: ADC DC Measurement 1

BIT	READ/ WRITE	RESET VALUE	DESCRIPTION
D7	R/W	0	0: DC measurement is Disabled for mono ADC channel 1: DC measurement is Enabled for mono ADC channel
D6	R/W	0	Reserved. Write only reset value.
D5	R/W	0	0: DC measurement is done based on 1st order sinc filter with averaging of 2^D 1: DC measurement is done based on 1st order low-pass IIR filter whose coefficients are calculated based on D value
D4–D0	R/W	00000	DC Measurement D setting: 00000: Reserved. Don't use. 00001: D = 1 00010: D = 2 ... 10011: D = 19 10100: D = 20 10101 to 11111: Reserved. Don't use.

Page 0/Register 103: ADC DC Measurement 2

BIT	READ/ WRITE	RESET VALUE	DESCRIPTION
D7	R/W	0	Reserved. Write only reset value.
D6	R/W	0	0: DC measurement data update is enabled. 1: DC measurement data update is disabled. User can read the last updated data without any data corruption.
D5	R/W	0	0: For IIR based DC measurement, the measurement value is the instantaneous output of the IIR filter 1: For IIR based DC measurement, the measurement value is update before periodic clearing of the IIR filter
D4–D0	R/W	00000	IIR based DC measurement, average time setting: 00000: Infinite average is used 00001: Averaging time is 2^1 ADC modulator clock periods 00010: Averaging time is 2^2 ADC modulator clock periods ... 10011: Averaging time is 2^{19} ADC modulator clock periods 10100: Averaging time is 2^{20} ADC modulator clock periods 10101 to 11111: Reserved. Don't use.

Page 0/Register 104–ADC DC Measurement Output 1

BIT	READ/ WRITE	RESET VALUE	DESCRIPTION
D7–D0	R	0000 0000	ADC DC Measurement Output (23:16)

Page 0/Register 105–ADC DC Measurement Output 2

BIT	READ/ WRITE	RESET VALUE	DESCRIPTION
D7–D0	R	0000 0000	ADC DC Measurement Output (15:8)

Page 0/Register 106–ADC DC Measurement Output 3

BIT	READ/ WRITE	RESET VALUE	DESCRIPTION
D7–D0	R	0000 0000	ADC DC Measurement Output (7:0)

Page 0/Registers 107–115: Reserved

BIT	READ/ WRITE	RESET VALUE	DESCRIPTION
D7–D0	R/W	XXXX XXXX	Reserved. Do not write to these registers.

Page 0/Register 116: VOL/MICDET-Pin SAR ADC – Volume Control

BIT	READ/ WRITE	RESET VALUE	DESCRIPTION																											
D7	R/W	0	0: DAC volume control is controlled by control register. (7-bit Vol ADC is powered down) 1: DAC volume control is controlled by pin.																											
D6	R/W	0	0: Internal on-chip RC oscillator is used for the 7-bit Vol ADC for pin volume control. 1: MCLK is used for the 7-bit Vol ADC for pin volume control.																											
D5–D4	R/W	00	00: No hysteresis for volume control ADC output 01: Hysteresis of ± 1 bit 10: Hysteresis of ± 2 bits 11: Reserved. Do not write this sequence to these bits.																											
D3	R/W	0	Reserved. Write only reset value.																											
D2–D0	R/W	000	Throughput of the 7-bit Vol ADC for pin volume control, frequency based on MCLK or internal oscillator. <table border="1" style="width: 100%; border-collapse: collapse;"> <thead> <tr> <th></th> <th>MCLK = 12 MHz</th> <th>Internal Oscillator Source</th> </tr> </thead> <tbody> <tr> <td>000: Throughput =</td> <td>15.625 Hz</td> <td>10.68 Hz</td> </tr> <tr> <td>001: Throughput =</td> <td>31.25 Hz</td> <td>21.35 Hz</td> </tr> <tr> <td>010: Throughput =</td> <td>62.5 Hz</td> <td>42.71 Hz</td> </tr> <tr> <td>011: Throughput =</td> <td>125 Hz</td> <td>8.2 Hz</td> </tr> <tr> <td>100: Throughput =</td> <td>250 Hz</td> <td>170 Hz</td> </tr> <tr> <td>101: Throughput =</td> <td>500 Hz</td> <td>340 Hz</td> </tr> <tr> <td>110: Throughput =</td> <td>1 kHz</td> <td>680 Hz</td> </tr> <tr> <td>111: Throughput =</td> <td>2 kHz</td> <td>1.37 kHz</td> </tr> </tbody> </table> <p>Note: These values are based on a nominal oscillator frequency of 8.2 MHz. Values will scale to the actual oscillator frequency.</p>		MCLK = 12 MHz	Internal Oscillator Source	000: Throughput =	15.625 Hz	10.68 Hz	001: Throughput =	31.25 Hz	21.35 Hz	010: Throughput =	62.5 Hz	42.71 Hz	011: Throughput =	125 Hz	8.2 Hz	100: Throughput =	250 Hz	170 Hz	101: Throughput =	500 Hz	340 Hz	110: Throughput =	1 kHz	680 Hz	111: Throughput =	2 kHz	1.37 kHz
	MCLK = 12 MHz	Internal Oscillator Source																												
000: Throughput =	15.625 Hz	10.68 Hz																												
001: Throughput =	31.25 Hz	21.35 Hz																												
010: Throughput =	62.5 Hz	42.71 Hz																												
011: Throughput =	125 Hz	8.2 Hz																												
100: Throughput =	250 Hz	170 Hz																												
101: Throughput =	500 Hz	340 Hz																												
110: Throughput =	1 kHz	680 Hz																												
111: Throughput =	2 kHz	1.37 kHz																												

Page 0/Register 117: VOL/MICDET-Pin Gain

BIT	READ/ WRITE	RESET VALUE	DESCRIPTION
D7	R/W	0	Reserved. Write only zero to this bit.
D6–D0	R	XXX XXXX	000 0000: Gain applied by pin volume control = 18 dB 000 0001: Gain applied by pin volume control = 17.5 dB 000 0010: Gain applied by pin volume control = 17 dB ... 010 0011: Gain applied by pin volume control = 0.5 dB 010 0100: Gain applied by pin volume control = 0 dB 010 0101: Gain applied by pin volume control = –0.5 dB ... 101 1001: Gain applied by pin volume control = –26.5 dB 101 1010: Gain applied by pin volume control = –27 dB 101 1011: Gain applied by pin volume control = –28 dB ... 111 1101: Gain applied by pin volume control = –62 dB 111 1110: Gain applied by pin volume control = –63 dB 111 1111: Reserved.

Page 0/Registers 118 to 127: Reserved

BIT	READ/ WRITE	RESET VALUE	DESCRIPTION
D7–D0	R/W	XXXX XXXX	Reserved. Do not write to these registers.

6.3 Control Registers, Page 1: DAC and ADC Routing, PGA, Power-Controls and MISC Logic Related Programmabilities
Page 1/Register 0: Page Control Register

BIT	READ/ WRITE	RESET VALUE	DESCRIPTION
D7–D0	R/W	0000 0000	0000 0000: Page 0 selected 0000 0001: Page 1 selected ... 1111 1110: Page 254 selected 1111 1111: Page 255 selected

Page 1/Registers 1–29: Reserved

BIT	READ/ WRITE	RESET VALUE	DESCRIPTION
D7–D0	R/W	XXXX XXXX	Reserved. Do not write to these registers.

Page 1/Register 30: Headphone and Speaker Amplifier Error Control

BIT	READ/ WRITE	RESET VALUE	DESCRIPTION
D7–D2	R/W	0000 00	Reserved
D1	R/W	0	0: Reset HPL and HPR power-up control bits on short-circuit detection if page-1, register 31, D1 = 1. 1: HPL and HPR power-up control bits remain unchanged on short-circuit detection.
D0	R/W	0	0: Reset SPL and SPR power-up control bits on short-circuit detection. 1: SPL and SPR power-up control bits remain unchanged on short-circuit detection.

Page 1/Register 31: Headphone Drivers

BIT	READ/ WRITE	RESET VALUE	DESCRIPTION
D7	R/W	0	0: HPL output driver is powered down. 1: HPL output driver is powered up.
D6	R/W	0	0: HPR output driver is powered down. 1: HPR output driver is powered up.
D5	R/W	0	Reserved. Write only zero to this bit.
D4–D3	R/W	0	00: Output common-mode voltage = 1.35 V 01: Output common-mode voltage = 1.5 V 10: Output common-mode voltage = 1.65 V 11: Output common-mode voltage = 1.8 V
D2	R/W	1	Reserved. Write only 1 to this bit.
D1	R/W	0	0: If short-circuit protection is enabled for headphone driver and short circuit detected, device limits the maximum current to the load. 1: If short-circuit protection is enabled for headphone driver and short circuit detected, device powers down the output driver.
D0	R	0	0: Short circuit is not detected on the headphone driver. 1: Short circuit is detected on the headphone driver.

Page 1/Register 32: Class-D Speaker Amplifier

BIT	READ/ WRITE	RESET VALUE	DESCRIPTION
D7	R/W	0	0: Left-channel class-D output driver is powered down. 1: Left-channel class-D output driver is powered up.
D6	R/W	0	0: Right-channel class-D output driver is powered down. 1: Right-channel class-D output driver is powered up.
D5–D1	R/W	00 011	Reserved. Write only the reset value to this bit.
D0	R	0	0: Short circuit is not detected on the class-D driver. Valid only if class-D amplifier is powered up. For short-circuit flag sticky bit, see page 0/register 44. 1: Short circuit is detected on the class-D driver. Valid only if class-D amp is powered-up. For short-circuit flag sticky bit, see page 0/register 44.

Page 1/Register 33: HP Output Drivers POP Removal Settings

BIT	READ/ WRITE	RESET VALUE	DESCRIPTION
D7	R/W	0	0: If power down sequence is activated by device software power down using page 1/register 46, bit D7, then power down the DAC simultaneously with the HP and SP amplifiers. 1: If power down sequence is activated by device software power down using page 1/register 46, bit D7, then power down DAC only after HP and SP amplifiers are completely powered down. This is to optimize power-down POP.
D6–D3	R/W	0111	0000: Driver power-on time = 0 μ s 0001: Driver power-on time = 15.3 μ s 0010: Driver power-on time = 153 μ s 0011: Driver power-on time = 1.53 ms 0100: Driver power-on time = 15.3 ms 0101: Driver power-on time = 76.2 ms 0110: Driver power-on time = 153 ms 0111: Driver power-on time = 304 ms 1000: Driver power-on time = 610ms 1001: Driver power-on time = 1.22 s 1010: Driver power-on time = 3.04 s 1011: Driver power-on time = 6.1 s 1100–1111: Reserved. Do not write these sequences to these bits. NOTE: These values are based on typical oscillator frequency of 8.2 MHz. Scale according to the actual oscillator frequency.
D2–D1	R/W	11	00: Driver ramp-up step time = 0 ms 01: Driver ramp-up step time = 0.98 ms 10: Driver ramp-up step time = 1.95 ms 11: Driver ramp-up step time = 3.9 ms NOTE: These values are based on typical oscillator frequency of 8.2 MHz. Scale according to the actual oscillator frequency.
D0	R/W	0	0: Weakly driven output common-mode voltage is generated from resistor divider of the AVDD supply. 1: Reserved

Page 1/Register 34: Output Driver PGA Ramp-Down Period Control

BIT	READ/ WRITE	RESET VALUE	DESCRIPTION
D7	R/W	0	Reserved. Write only the reset value to this bit.
D6–D4	R/W	000	Speaker Power-Up Wait Time (Duration Based on Using Internal Oscillator) 000: Wait time = 0 ms 001: Wait time = 3.04 ms 010: Wait time = 7.62 ms 011: Wait time = 12.2 ms 100: Wait time = 15.3 ms 101: Wait time = 19.8 ms 110: Wait time = 24.4 ms 111: Wait time = 30.5 ms NOTE: These values are based on typical oscillator frequency of 8.2 MHz. Scale according to the actual oscillator frequency.
D3–D0	R/W	0000	Reserved. Write only the reset value to these bits.

Page 1/Register 35: DAC_L and DAC_R Output Mixer Routing

BIT	READ/ WRITE	RESET VALUE	DESCRIPTION
D7–D6	R/W	00	00: DAC_L is not routed anywhere. 01: DAC_L is routed to the left-channel mixer amplifier. 10: DAC_L is routed directly to the HPL driver. 11: Reserved
D5	R/W	0	0: MIC input is not routed to the left-channel mixer amplifier. 1: MIC input is routed to the left-channel mixer amplifier.
D4		0	0: AUX1 input is not routed to the left-channel mixer amplifier. 1: AUX1 input is routed to the left-channel mixer amplifier.
D3–D2	R/W	00	00: DAC_R is not routed anywhere. 01: DAC_R is routed to the right-channel mixer amplifier. 10: DAC_R is routed directly to the HPR driver. 11: Reserved
D1	R/W	0	0: AUX1 input is not routed to the right-channel mixer amplifier. 1: AUX1 input is routed to the right-channel mixer amplifier.
D0	R/W	0	0: HPL driver output is not routed to the HPR driver. 1: HPL driver output is routed to the HPR driver input (used for differential output mode).

Page 1/Register 36: Left Analog Vol to HPL

BIT	READ/ WRITE	RESET VALUE	DESCRIPTION
D7	R/W	0	0: Left-channel analog volume control is not routed to HPL output driver. 1: Left-channel analog volume control is routed to HPL output driver.
D6–D0	R/W	111 1111	Left-channel analog volume control gain (non-linear) for the HPL output driver, 0 dB to –78 dB. See Table 5-38 .

Page 1/Register 37: Right Analog Vol to HPR

BIT	READ/ WRITE	RESET VALUE	DESCRIPTION
D7	R/W	0	0: Right-channel analog volume control is not routed to HPR output driver. 1: Right-channel analog volume control is routed to HPR output driver.
D6–D0	R/W	111 1111	Right-channel analog volume control gain (non-linear) for the HPR output driver, 0 dB to –78 dB. See Table 5-38 .

Page 1/Register 38: Left Analog Vol to SPL

BIT	READ/ WRITE	RESET VALUE	DESCRIPTION
D7	R/W	0	0: Left-channel analog volume control output is not routed to left-channel class-D output driver. 1: Left-channel analog volume control output is routed to left-channel class-D output driver.
D6–D0	R/W	111 1111	Left-channel analog volume control output gain (non-linear) for the left-channel class-D output driver, 0 dB to –78 dB. See Table 5-38 .

Page 1/Register 39: Right Analog Vol to SPR

BIT	READ/ WRITE	RESET VALUE	DESCRIPTION
D7	R/W	0	0: Right-channel analog volume control output is not routed to right-channel class-D output driver. 1: Right-channel analog volume control output is routed to right-channel class-D output driver.
D6–D0	R/W	111 1111	Right-channel analog volume control output gain (non-linear) for the right-channel class-D output driver, 0 dB to –78 dB. See Table 5-38 .

Page 1/Register 40: HPL Driver

BIT	READ/ WRITE	RESET VALUE	DESCRIPTION
D7	R/W	0	Reserved. Write only zero to this bit.
D6–D3	R/W	0000	0000: HPL driver PGA = 0 dB 0001: HPL driver PGA = 1 dB 0010: HPL driver PGA = 2 dB ... 1000: HPL driver PGA = 8 dB 1001: HPL driver PGA = 9 dB 1010–1111: Reserved. Do not write these sequences to these bits.
D2	R/W	0	0: HPL driver is muted. 1: HPL driver is not muted.
D1	R/W	1	0: HPL driver is weakly driven to a common mode during power down. ⁽¹⁾ 1: HPL driver is high-impedance during power down.
D0	R	0	0: Not all programmed gains to HPL have been applied yet. 1: All programmed gains to HPL have been applied.

(1) If D1 is programmed as 0, Page 1 / Register 33 D0 must be set to 0.

Page 1/Register 41: HPR Driver

BIT	READ/ WRITE	RESET VALUE	DESCRIPTION
D7	R/W	0	Reserved. Write only zero to this bit.
D6–D3	R/W	0000	0000: HPR driver PGA = 0 dB 0001: HPR driver PGA = 1 dB 0010: HPR driver PGA = 2 dB ... 1000: HPR driver PGA = 8 dB 1001: HPR driver PGA = 9 dB 1010–1111: Reserved. Do not write these sequences to these bits.
D2	R/W	0	0: HPR driver is muted. 1: HPR driver is not muted.
D1	R/W	1	0: HPR driver is weakly driven to a common mode during power down. ⁽¹⁾ 1: HPR driver is high-impedance during power down.
D0	R	0	0: Not all programmed gains to HPR have been applied yet. 1: All programmed gains to HPR have been applied.

(1) If D1 is programmed as 0, Page 1 / Register 33 D0 must be set to 0.

Page 1/Register 42: SPL Driver

BIT	READ/ WRITE	RESET VALUE	DESCRIPTION
D7–D5	R/W	000	Reserved. Write only zeros to these bits.
D4–D3	R/W	00	00: Left-channel class-D driver output stage gain = 6 dB 01: Left-channel class-D driver output stage gain = 12 dB 10: Left-channel class-D driver output stage gain = 18 dB 11: Left-channel class-D driver output stage gain = 24 dB
D2	R/W	0	0: Left-channel class-D driver is muted. 1: Left-channel class-D driver is not muted.
D1	R/W	0	Reserved. Write only zero to this bit.
D0	R	0	0: Not all programmed gains to left-channel class-D driver have been applied yet. 1: All programmed gains to left-channel class-D driver have been applied.

Page 1/Register 43: SPR Driver

BIT	READ/ WRITE	RESET VALUE	DESCRIPTION
D7–D5	R/W	000	Reserved. Write only zeros to these bits.
D4–D3	R/W	00	00: Right-channel class-D driver output stage gain = 6 dB 01: Right-channel class-D driver output stage gain = 12 dB 10: Right-channel class-D driver output stage gain = 18 dB 11: Right-channel class-D driver output stage gain = 24 dB
D2	R/W	0	0: Right-channel class-D driver is muted. 1: Right-channel class-D driver is not muted.
D1	R/W	0	Reserved. Write only zero to this bit.
D0	R	0	0: Not all programmed gains to right-channel class-D driver have been applied yet. 1: All programmed gains to right-channel class-D driver have been applied.

Page 1/Register 44: HP Driver Control

BIT	READ/ WRITE	RESET VALUE	DESCRIPTION																								
D7–D5	R/W	000	Debounce time for the headset short-circuit detection																								
			<table border="1"> <thead> <tr> <th>(1)</th> <th>MCLK/DIV (Page 3/Register 16) = 1-MHz Source</th> <th>Internal Oscillator Source</th> </tr> </thead> <tbody> <tr> <td>000: Debounce time =</td> <td>0 μs</td> <td>0 μs</td> </tr> <tr> <td>001: Debounce time =</td> <td>8 μs</td> <td>7.8 μs</td> </tr> <tr> <td>010: Debounce time =</td> <td>16 μs</td> <td>15.6 μs</td> </tr> <tr> <td>011: Debounce time =</td> <td>32 μs</td> <td>31.2 μs</td> </tr> <tr> <td>100: Debounce time =</td> <td>64 μs</td> <td>62.4 μs</td> </tr> <tr> <td>101: Debounce time =</td> <td>128 μs</td> <td>124.9 μs</td> </tr> <tr> <td>110: Debounce time =</td> <td>256 μs</td> <td>250 μs</td> </tr> <tr> <td>111: Debounce time =</td> <td>512 μs</td> <td>500 μs</td> </tr> </tbody> </table> <p>Note: These values are based on a nominal oscillator frequency of 8.2 MHz. Values will scale to the actual oscillator frequency.</p>	(1)	MCLK/DIV (Page 3/Register 16) = 1-MHz Source	Internal Oscillator Source	000: Debounce time =	0 μ s	0 μ s	001: Debounce time =	8 μ s	7.8 μ s	010: Debounce time =	16 μ s	15.6 μ s	011: Debounce time =	32 μ s	31.2 μ s	100: Debounce time =	64 μ s	62.4 μ s	101: Debounce time =	128 μ s	124.9 μ s	110: Debounce time =	256 μ s	250 μ s
(1)	MCLK/DIV (Page 3/Register 16) = 1-MHz Source	Internal Oscillator Source																									
000: Debounce time =	0 μ s	0 μ s																									
001: Debounce time =	8 μ s	7.8 μ s																									
010: Debounce time =	16 μ s	15.6 μ s																									
011: Debounce time =	32 μ s	31.2 μ s																									
100: Debounce time =	64 μ s	62.4 μ s																									
101: Debounce time =	128 μ s	124.9 μ s																									
110: Debounce time =	256 μ s	250 μ s																									
111: Debounce time =	512 μ s	500 μ s																									
D4–D3	R/W	00	00: Default mode for the DAC 01: DAC performance increased by increasing the current 10: Reserved 11: DAC performance increased further by increasing the current again																								
D2	R/W	0	0: HPL output driver is programmed as headphone driver. 1: HPL output driver is programmed as lineout driver.																								
D1	R/W	0	0: HPR output driver is programmed as headphone driver. 1: HPR output driver is programmed as lineout driver.																								
D0	R/W	0	Reserved. Write only zero to this bit.																								

(1) The clock used for the debounce has a clock period = debounce duration/8.

Page 1/Register 45: Reserved

BIT	READ/ WRITE	RESET VALUE	DESCRIPTION
D7–D0	R/W	XXXX XXXX	Reserved. Do not write to these registers.

Page 1/Register 46: MICBIAS

BIT	READ/ WRITE	RESET VALUE	DESCRIPTION
D7	R/W	0	0: Device software power down is not enabled. 1: Device software power down is enabled.
D6–D4	R/W	000	Reserved. Write only zeros to these bits.
D3	R/W	0	0: Programmed MICBIAS is not powered up if headset detection is enabled but headset is not inserted. 1: Programmed MICBIAS is powered up even if headset is not inserted.
D2	R/W	0	Reserved. Write only zero to this bit.
D1–D0	R/W	00	00: MICBIAS output is powered down. 01: MICBIAS output is powered to 2 V. 10: MICBIAS output is powered to 2.5 V. 11: MICBIAS output is powered to AVDD.

Page 1/Register 47: MIC PGA

BIT	READ/ WRITE	RESET VALUE	DESCRIPTION
D7	R/W	1	0: MIC PGA is controlled by bits D6–D0. 1: MIC PGA is at 0 dB.
D6–D0	R/W	000 0000	000 0000: PGA = 0 dB 000 0001: PGA = 0.5 dB 000 0010: PGA = 1 dB ... 111 0110: PGA = 59 dB 111 0111: PGA = 59.5 dB 111 1000–111 1111: Reserved. Do not write these sequences to these bits.

Page 1/Register 48: Delta-Sigma Mono ADC Channel Fine-Gain Input Selection for P-Terminal

BIT	READ/ WRITE	RESET VALUE	DESCRIPTION
D7–D6 (1)	R/W	00	00: MIC is not selected for the MIC PGA. 01: MIC is selected for the MIC PGA with feed-forward resistance RIN = 10 kΩ. 10: MIC is selected for the MIC PGA with feed-forward resistance RIN = 20 kΩ. 11: MIC is selected for the MIC PGA with feed-forward resistance RIN = 40 kΩ.
D5–D4	R/W	00	00: AUX1 is not selected for the MIC PGA. 01: AUX1 is selected for the MIC PGA with feed-forward resistance RIN = 10 kΩ 10: AUX1 is selected for the MIC PGA with feed-forward resistance RIN = 20 kΩ 11: AUX1 is selected for the MIC PGA with feed-forward resistance RIN = 40 kΩ
D3–D2	R/W	00	00: AUX2 is not selected for the MIC PGA. 01: AUX2 is selected for the MIC PGA with feed-forward resistance RIN = 10 kΩ 10: AUX2 is selected for the MIC PGA with feed-forward resistance RIN = 20 kΩ 11: AUX2 is selected for the MIC PGA with feed-forward resistance RIN = 40 kΩ
D1–D0	R/W	00	Reserved. Write only zeros to these bits.

(1) Input impedance selection affects the microphone PGA gain. See the [MICBIAS](#) and [Microphone Pre-amplifier](#) section for details.

Page 1/Register 49: ADC Input Selection for M-Terminal

BIT	READ/ WRITE	RESET VALUE	DESCRIPTION
D7–D6 (1)	R/W	00	00: CM is not selected for the MIC PGA. 01: CM is selected for the MIC PGA with feed-forward resistance RIN = 10 kΩ. 10: CM is selected for the MIC PGA with feed-forward resistance RIN = 20 kΩ. 11: CM is selected for the MIC PGA with feed-forward resistance RIN = 40 kΩ.
D5–D4		00	00: AUX2 is not selected for the left MIC PGA. 01: AUX2 is selected for the MIC PGA with feed-forward resistance RIN = 10 kΩ. 10: AUX2 is selected for the MIC PGA with feed-forward resistance RIN = 20 kΩ. 11: AUX2 is selected for the MIC PGA with feed-forward resistance RIN = 40 kΩ.
D3–D0	R/W	0000	Reserved. Write only zeros to these bits.

(1) Input impedance selection affects the microphone PGA gain. See the [MICBIAS](#) and [Microphone Pre-amplifier](#) section for details.

Page 1/Register 50: Input CM Settings

BIT	READ/ WRITE	RESET VALUE	DESCRIPTION
D7	R/W	0	0: MIC input is floating, if it is not used for the MIC PGA and analog bypass. 1: MIC input is connected to CM internally, if it is not used for the MIC PGA and analog bypass.
D6	R/W	0	0: AUX1 input is floating, if it is not used for the MIC PGA and analog bypass. 1: AUX1 input is connected to CM internally, if it is not used for the MIC PGA and analog bypass.
D5	R/W	0	0: AUX2 input is floating, if it is not used for the MIC PGA. 1: AUX2 input is connected to CM internally, if it is not used for the MIC PGA.
D4–D1	R/W	0000	Reserved. Write only zeros to these bits.
D0	R	0	0: Not all programmed analog gains to the ADC have been applied yet. 1: All programmed analog gains to the ADC have been applied.

Page 1/Registers 51–127: Reserved

BIT	READ/ WRITE	RESET VALUE	DESCRIPTION
D7–D0	R/W	XXXX XXXX	Reserved. Write only the reset value to these bits.

6.4 Control Registers, Page 3: TSC Control and Data Programmabilities

Page 3/Register 0: Page Control Register

BIT	READ/ WRITE	RESET VALUE	DESCRIPTION
D7–D0	R/W	0000 0000	0000 0000: Page 0 selected 0000 0001: Page 1 selected ... 1111 1110: Page 254 selected 1111 1111: Page 255 selected

Page3/Register 1: Reserved

BIT	READ/ WRITE	RESET VALUE	DESCRIPTION
D7–D0	R/W	XXXX XXXX	Reserved. Write only the reset value to these bits.

Page 3/Register 2: SAR ADC Control

BIT	READ/ WRITE	RESET VALUE	DESCRIPTION
D7	R/W	0	0: Normal mode 1: Stop conversion and power down SAR ADC.
D6–D5	R/W	00	00: SAR ADC resolution = 12-bit 01: SAR ADC resolution = 8-bit 10: SAR ADC resolution = 10-bit 11: SAR ADC resolution = 12-bit
D4–D3 See Figure 5-40	R/W	00	00: SAR ADC clock divider = 1 (Use for 8-bit resolution case only) (This divider is only for the conversion clock generation, not for other logic.) 01: SAR ADC clock divider = 2 (Use for 8-bit/10-bit resolution case only.) 10: SAR ADC clock divider = 4 (For better performance in 8-bit/10-bit resolution mode, this setting is recommended.) 11: SAR ADC clock divider = 8 (For better performance in 12-bit resolution mode, this setting is recommended.)
D2	R/W	000	0: Mean filter is used for on-chip data averaging (if enabled). 1: Median filter is used for on-chip data averaging (if enabled).
D1–D0	R/W		00: On-chip data averaging is disabled. 01: 4-data averaging in case mean filter/5-data averaging in case of median filter 10: 8-data averaging in case mean filter/9-data averaging in case of median filter 11: 16-data averaging in case mean filter/15-data averaging in case of median filter

Page 3/Register 3: SAR ADC Control

BIT	READ/ WRITE	RESET VALUE	DESCRIPTION
D7	R/W	0	0: Host-controlled conversions 1: Self-controlled touch screen conversions based on pen touch
D6	R/W	0	Reserved. Write only zero to this bit.
D5–D2	R/W	0000	0000: Conversion mode = No scan 0001: Conversion mode = (X, Y) scan: Even in host-controlled mode, once started, scan continues until either the pen is lifted or a stop bit (register 2, bit D7) is sent. 0010: Conversion mode = (X, Y, Z1, Z2) scan: Even in host-controlled mode, once started, scan continues until either the pen is lifted or a stop bit (register 2, bit D7) is sent. 0011: Conversion mode = X scan: Only in self-controlled mode; once started, scan continues until either the pen is lifted or a stop bit (register 2, bit D7) is sent. 0100: Conversion mode = Y scan: Only in self-controlled mode; once started, scan continues until either the pen is lifted or a stop bit (register 2, bit D7) is sent. 0101: Conversion Mode = (Z1, Z2) scan: Only in self-controlled mode; once started, scan continues until either the pen is lifted or a stop bit (register 2, bit D7) is sent. 0110: Conversion mode = VBAT measurement 0111: Conversion mode = AUX2 measurement 1000: Conversion mode = AUX1 measurement 1001: Conversion mode = Auto scan. Sequence used is AUX1, AUX2, VBAT. Each of these inputs can be enabled or disabled independently using register 19, and with that sequence is modified accordingly. Scan continues until stop bit (register 2, bit D7) is sent or bits D5–D2 of this register are changed. 1010: Conversion mode = TEMP1 measurement 1011: Conversion mode = Port scan: AUX1, AUX2, VBAT 1100: Conversion mode = TEMP2 measurement 1101–1111: Reserved. Do not write these sequences to these bits.
D1–D0	R/W	0	00: Interrupt pin (GPIO1 or GPIO2 pin) = PEN-interrupt $\overline{\text{PENIRQ}}$ (active low). 01: Interrupt pin (GPIO1 or GPIO2 pin) = Data-available DATA_AVA (active low). 10: Interrupt pin (GPIO1 or GPIO2 pin) = PEN-interrupt PENIRQ and Data-available DATA_AVA (active high). 11: Reserved

Page 3/Register 4: Precharge and Sense

BIT	READ/ WRITE	RESET VALUE	DESCRIPTION		
D7	R/W	0	0: Pen touch detection is enabled. 1: Pen touch detection is disabled.		
D6–D4	R/W	000	Precharge time before touch detection [duration based on using internal oscillator or MCLK/DIV (register 17)]		
				MCLK/DIV = 8-MHz Source	Internal Oscillator Source
			000: Precharge time = 001: Precharge time = 010: Precharge time = 011: Precharge time = 100: Precharge time = 101: Precharge time = 110: Precharge time = 111: Precharge time =	0.25 μ s 1 μ s 3 μ s 10 μ s 30 μ s 100 μ s 300 μ s 1 ms	0.24 μ s 0.97 μ s 2.92 μ s 9.7 μ s 29.2 μ s 97 μ s 292 μ s 0.97 ms Note: These values are based on a nominal oscillator frequency of 8.2 MHz. Values will scale to the actual oscillator frequency.
D3	R/W	0	Reserved. Write only zero to this bit.		
D2–D0	R/W	000	Sense time during touch detection [duration based on using internal oscillator or MCLK/DIV (register 17)]		
				MCLK/DIV = 8-MHz Source	Internal Oscillator Source
			000: Sense time = 001: Sense time = 010: Sense time = 011: Sense time = 100: Sense time = 101: Sense time = 110: Sense time = 111: Sense time =	1 μ s 2 μ s 3 μ s 10 μ s 30 μ s 100 μ s 300 μ s 1 ms	0.97 μ s 1.94 μ s 2.92 μ s 9.7 μ s 29.2 μ s 97 μ s 292 μ s 0.97 ms Note: These values are based on a nominal oscillator frequency of 8.2 MHz. Values will scale to the actual oscillator frequency.

Page 3/Register 5: Panel Voltage Stabilization

BIT	READ/ WRITE	RESET VALUE	DESCRIPTION		
D7–D6	R/W	000	00: SAR comparator bias current normal setting. 01: Increase the SAR comparator bias by 25% to support higher conversion clock. 10: Increase the SAR comparator bias by 50% to support higher conversion clock 11: Increase the SAR comparator bias by 100% to support higher conversion clock.		
D5	R/W	0	0: Default sample duration. 1: Sample duration doubles to support inputs which are higher output impedance..		
D4–D3	R/W	00	Reserved. Write only zeroes to these bits.		
D2–D0	R/W	000	Panel voltage stabilization time before conversion [(duration based on using internal oscillator or MCLK/DIV (register 17)]		
				MCLK/DIV = 8-MHz Source	Internal Oscillator Source
			000: Stabilization time = 001: Stabilization time = 010: Stabilization time = 011: Stabilization time = 100: Stabilization time = 101: Stabilization time = 110: Stabilization time = 111: Stabilization time =	0.25 μ s 1 μ s 3 μ s 10 μ s 30 μ s 100 μ s 300 μ s 1 ms	0.24 μ s 0.97 μ s 2.92 μ s 9.7 μ s 29.2 μ s 97 μ s 292 μ s 0.97 ms Note: These values are based on a nominal oscillator frequency of 8.2 MHz. Values will scale to the actual oscillator frequency.

Page 3/Register 6: Voltage Reference

BIT	READ/ WRITE	RESET VALUE	DESCRIPTION
D7	R/W	0	0: External reference is used for non-touch-screen measurement. 1: Internal reference is used for non-touch-screen measurement.
D6	R/W	0	0: Internal reference = 1.25 V 1: Internal reference = 2.5 V
D5	R/W	1	0: Internal reference powered up continuously for conversions 1: Internal reference powered up/down automatically based on whether conversion is in progress.
D4	R/W	0	Reserved
D3–D2	R/W	00	Reference Stabilization Time Before Conversion 00: 0 μ s 01: 100 μ s 10: 500 μ s 11: 1 ms Note: These values are based on MCLK/DIV (page 3/register 17) = 8 MHz. Scale according to the actual oscillator frequency.
D1	R/W	0	Reserved
D0	R/W	0	0: VBAT is the normal auxillary input ($V_{BAT} \leq V_{REF}$). 1: VBAT = BAT is the battery input for battery measurement.

Page 3/Registers 7 to 8: Reserved

BIT	READ/ WRITE	RESET VALUE	DESCRIPTION
D7–D0	R/W	XXXX XXXX	Reserved. Write only the reset value to these bits.

Page 3/Register 9: Status Bit

BIT	READ/ WRITE	RESET VALUE	Description
D7	R	0	0: Pen touch is not detected. 1: Pen touch is detected.
D6	R	1	0: ADC is busy. 1: ADC is not busy.
D5	R	0	0: No new data is available. 1: New data is available. (This bit is cleared only after all the converted data have been completely read out. This bit is not valid for the buffer mode.)
D4	R/W	X	Reserved. Write only the reset value to this bit.
D3	R	0	0: No new X data is available. 1: New data for X coordinate is available. (This bit is cleared only after the converted X data have been read out. This bit is not valid for the buffer mode.)
D2	R	0	0: No new Y data is available. 1: New data for Y coordinate is available. (This bit is cleared only after the converted Y data have been read out. This bit is not valid for the buffer mode.)
D1	R	0	0: No new Z1 data is available. 1: New data for Z1 coordinate is available. (This bit is cleared only after the converted Z1 data have been read out. This bit is not valid for the buffer mode.)
D0	R	0	0: No new Z2 data is available. 1: New data for Z2 coordinate is available. (This bit is cleared only after the converted Z2 data have been read out. This bit is not valid for the buffer mode.)

Page 3/Register 10: Status Bit

BIT	READ/ WRITE	RESET VALUE	DESCRIPTION
D7	R	0	0: No new AUX1 data is available. 1: New data for AUX1 is available. (This bit is cleared only after the converted AUX1 data have been read out. This bit is not valid for the buffer mode.)
D6	R	0	0: No new AUX2 data is available. 1: New data for AUX2 is available. (This bit is cleared only after the converted AUX2 data have been read out. This bit is not valid for the buffer mode.)
D5	R	0	0: No new VBAT data is available. 1: New data for VBAT is available. (This bit is cleared only after the converted VBAT (BAT) data have been read out. This bit is not valid for the buffer mode.)
D4–D2	R/W	XXX	Reserved. Write only zeros to these bits.
D1	R	0	0: No new TEMP1 data is available. 1: New data for TEMP1 is available. (This bit is cleared only after the converted TEMP1 data have been read out. This bit is not valid for the buffer mode.)
D0	R	0	0: No new TEMP2 data is available. 1: New data for TEMP2 is available. (This bit is cleared only after the converted TEMP2 data have been read out. This bit is not valid for the buffer mode.)

Page 3/Registers 11 to 12: Reserved

BIT	READ/ WRITE	RESET VALUE	DESCRIPTION
D7–D0	R/W	XXXX XXXX	Reserved. Write only the reset value to these bits.

Page 3/Register 13: Buffer Mode

BIT	READ/ WRITE	RESET VALUE	DESCRIPTION
D7	R/W	0	0: Buffer mode is disabled and RDPTR, WRPTR, and TGPTR are set to their default values. 1: Buffer mode is enabled.
D6	R/W	0	0: Buffer mode is enabled as continuous-conversion mode. 1: Buffer mode is enabled as single-shot mode.
D5–D3	R/W	000	000: Trigger level for conversion = 8 × number of converted data. 001: Trigger level for conversion = 16 × number of converted data. 010: Trigger level for conversion = 24 × number of converted data. 011: Trigger level for conversion = 32 × number of converted data. 100: Trigger level for conversion = 40 × number of converted data. 101: Trigger level for conversion = 48 × number of converted data. 110: Trigger level for conversion = 56 × number of converted data. 111: Trigger level for conversion = 64 × number of converted data.
D2	R/W	0	Reserved
D1	R	0	0: Buffer is not full. 1: Buffer is full. This means buffer contains 64 unread converted data.
D0	R	1	0: Buffer is not empty 1: Buffer is empty. This means there is no unread converted data in the buffer.

Page 3/Register 14: Reserved

BIT	READ/ WRITE	RESET VALUE	DESCRIPTION
D7–D0	R/W	00001111	Reserved. Write only the reset value to these bits.

Page 3/Register 15: Scan Mode Timer

BIT	READ/ WRITE	RESET VALUE	DESCRIPTION		
D7	R/W	0	0: Programmable delay for touch-screen measurement is disabled. ⁽¹⁾ 1: Programmable delay for touch-screen measurement is enabled.		
D6–D4	R/W	100	Programmable interval timer delay [duration based on using internal oscillator or MCLK/DIV (page 3/register 16, bit D7)] ⁽²⁾		
				MCLK/DIV = 1-MHz Source	Internal Oscillator Source
			000: Delay time = 001: Delay time = 010: Delay time = 011: Delay time = 100: Delay time = 101: Delay time = 110: Delay time = 111: Delay time =	8 ms 1 ms 2 ms 3 ms 4 ms 5 ms 6 ms 7 ms	7.80 ms 0.97 ms 1.95 ms 2.93 ms 3.91 ms 4.88 ms 5.85 ms 6.83 ms NOTE: These values are based on typical oscillator frequency of 8.2 MHz. Scale according to the actual oscillator frequency.
D3	R/W	0	0: Programmable delay for non-touch screen auto measurement is disabled. 1: Programmable delay for non-touch screen auto measurement is enabled.		
D2–D0	R/W	0	Programmable interval timer delay [duration based on using internal oscillator or MCLK/DIV (page 3/register 16, bit D7)] ⁽²⁾		
				MCLK/DIV = 1-MHz Source	Internal Oscillator Source
			000: Delay time = 001: Delay time = 010: Delay time = 011: Delay time = 100: Delay time = 101: Delay time = 110: Delay time = 111: Delay time =	1.12 min. 3.36 min. 5.59 min. 7.83 min. 10.01 min. 12.30 min. 14.54 min. 16.78 min.	1.09 min. 3.28 min. 5.46 min. 7.64 min. 9.76 min. 12.0 min. 14.2 min. 16.37 min. NOTE: These values are based on typical oscillator frequency of 8.2 MHz. Scale according to the actual oscillator frequency.

(1) This interval timer mode is for all self-controlled modes. For host-controlled mode, it is valid only for (X, Y) or (X, Y, Z1, Z2) conversions.

(2) These delays are from the end of one data set of conversion to the start of another new data set of conversion.

Page 3/Register 16: Scan Mode Timer Clock

BIT	READ/ WRITE	RESET VALUE	DESCRIPTION
D7	R/W	1	0: Internal oscillator clock is used for programmable delay timer. 1: External MCLK ⁽¹⁾ is used for programmable delay timer.
D6–D0	R/W	000 0001	MCLK Divider to Generate 1-MHz Clock for the Programmable Delay Timer 000 0000: MCLK divider = 128. 000 0001: MCLK divider = 1. 000 0010: MCLK divider = 2. ... 111 1110: MCLK divider = 126. 111 1111: MCLK divider = 127.

(1) External clock is used only to control the delay programmed between the conversions and not used for doing the actual conversion. This is supported to get an accurate delay, because the internal oscillator frequency varies from device to device.

Page 3/Register 17: SAR ADC Clock

BIT	READ/ WRITE	RESET VALUE	DESCRIPTION
D7	R/W	1	0: Internal oscillator clock is used for SAR ADC and TSC FSM. 1: External MCLK is used for SAR ADC and TSC FSM. ⁽¹⁾
D6–D0	R/W	000 0001	MCLK Divider to Generate Clock With Minimum Pulse Duration Greater Than 40 ns for the SAR 000 0000: MCLK divider = 128 000 0001: MCLK divider = 1 000 0010: MCLK divider = 2 ... 111 1110: MCLK divider = 126 111 1111: MCLK divider = 127

(1) This enables the external clock for SAR ADC conversions and TSC FSM related timers like precharge, sense, ..., but not for programmable delay. For programmable delay, use the preceding register settings.

Page 3/Register 18: Debounce Time for Pen-Up Detection

BIT	READ/ WRITE	RESET VALUE	DESCRIPTION																											
D7	R/W	0	0: SPI Interface is used for the buffer data reading. 1: I ² C Interface is used for the buffer data reading.																											
D6	R/W	0	0: SAR/buffer data update is held automatically (to avoid simultaneous buffer read and write operations) based on internal detection logic. 1: SAR/buffer data update is held using software control and register 18, bit D5.																											
D5	R/W	0	0: SAR/buffer data update is enabled all the time. (This is valid only if register 18, bit D6 = 1.) 1: SAR/buffer data update is stopped so that user can read the last updated data without any data corruption. (This is valid only if above D6 = 1.)																											
D4–D3	R/W	00	Reserved. Write only zeros to these bits.																											
D2–D0	R/W	000	Pen-touch removal detection with debounce																											
			<table border="1"> <thead> <tr> <th>(1)</th> <th>MCLK/DIV (Page 3/Register 16) = 1-MHz Source</th> <th>Internal Oscillator Source</th> </tr> </thead> <tbody> <tr> <td>000: Debounce time =</td> <td>0 μs</td> <td>0 μs</td> </tr> <tr> <td>001: Debounce time =</td> <td>8 μs</td> <td>7.8 μs</td> </tr> <tr> <td>010: Debounce time =</td> <td>16 μs</td> <td>15.6 μs</td> </tr> <tr> <td>011: Debounce time =</td> <td>32 μs</td> <td>31.2 μs</td> </tr> <tr> <td>100: Debounce time =</td> <td>64 μs</td> <td>62.4 μs</td> </tr> <tr> <td>101: Debounce time =</td> <td>128 μs</td> <td>124.9 μs</td> </tr> <tr> <td>110: Debounce time =</td> <td>256 μs</td> <td>250 μs</td> </tr> <tr> <td>111: Debounce time =</td> <td>512 μs</td> <td>500 μs</td> </tr> </tbody> </table> <p>Note: These values are based on a nominal oscillator frequency of 8.2 MHz. Values will scale to the actual oscillator frequency.</p>	(1)	MCLK/DIV (Page 3/Register 16) = 1-MHz Source	Internal Oscillator Source	000: Debounce time =	0 μs	0 μs	001: Debounce time =	8 μs	7.8 μs	010: Debounce time =	16 μs	15.6 μs	011: Debounce time =	32 μs	31.2 μs	100: Debounce time =	64 μs	62.4 μs	101: Debounce time =	128 μs	124.9 μs	110: Debounce time =	256 μs	250 μs	111: Debounce time =	512 μs	500 μs
(1)	MCLK/DIV (Page 3/Register 16) = 1-MHz Source	Internal Oscillator Source																												
000: Debounce time =	0 μs	0 μs																												
001: Debounce time =	8 μs	7.8 μs																												
010: Debounce time =	16 μs	15.6 μs																												
011: Debounce time =	32 μs	31.2 μs																												
100: Debounce time =	64 μs	62.4 μs																												
101: Debounce time =	128 μs	124.9 μs																												
110: Debounce time =	256 μs	250 μs																												
111: Debounce time =	512 μs	500 μs																												

(1) The clock used for the debounce has a clock period = debounce duration/8.

Page 3/Register 19: Auto AUX Measurement Selection

BIT	READ/ WRITE	RESET VALUE	DESCRIPTION
D7	R/W	0	0: Auto AUX1 measurement is disabled during auto non-touch screen scan. 1: Auto AUX1 measurement is enabled during auto non-touch screen scan.
D6	R/W	0	0: Auto AUX2 measurement is disabled during auto non-touch screen scan. 1: Auto AUX2 measurement is enabled during auto non-touch screen scan.
D5	R/W	0	0: Auto VBAT measurement is disabled during auto non-touch screen scan. 1: Auto VBAT measurement is enabled during auto non-touch screen scan.
D4	R/W	0	0: Auto TEMP measurement is disabled during auto non-touch screen scan. 1: Auto TEMP measurement is enabled during auto non-touch screen scan.
D3	R/W	0	0: TEMP1 is used for auto TEMP measurement. 1: TEMP2 is used for auto TEMP measurement.
D2	R/W	0	0: AUX1 is used for voltage measurement. 1: AUX1 is used for resistance measurement.
D1	R/W	0	0: AUX2 is used for voltage measurement. 1: AUX2 is used for resistance measurement.
D0	R/W	0	0: Internal bias resistance measurement mode is used during resistance measurement. 1: External bias resistance measurement mode is used during resistance measurement.

Page 3/Register 20: Touch-Screen Pen Down

BIT	READ/ WRITE	RESET VALUE	DESCRIPTION																											
D7–D3	R/W	0000 0	Reserved																											
D2–D0	R/W	000	Debounce Time for Pen-Down Detection																											
			<table border="1"> <thead> <tr> <th>(1)</th> <th>MCLK/DIV (Page 3/ Register 16) = 1-MHz Source</th> <th>Internal Oscillator Source</th> </tr> </thead> <tbody> <tr> <td>000: Debounce time =</td> <td>0 μs</td> <td>0 μs</td> </tr> <tr> <td>001: Debounce time =</td> <td>64 μs</td> <td>62.4 μs</td> </tr> <tr> <td>010: Debounce time =</td> <td>128 μs</td> <td>125 μs</td> </tr> <tr> <td>011: Debounce time =</td> <td>256 μs</td> <td>250 μs</td> </tr> <tr> <td>100: Debounce time =</td> <td>512 μs</td> <td>500 μs</td> </tr> <tr> <td>101: Debounce time =</td> <td>1024 μs</td> <td>1000 μs</td> </tr> <tr> <td>110: Debounce time =</td> <td>2048 μs</td> <td>2000 μs</td> </tr> <tr> <td>111: Debounce time =</td> <td>4096 μs</td> <td>4000 μs</td> </tr> </tbody> </table> <p>NOTE: These values are based on typical oscillator frequency of 8.2 MHz. Scale according to the actual oscillator frequency.</p>	(1)	MCLK/DIV (Page 3/ Register 16) = 1-MHz Source	Internal Oscillator Source	000: Debounce time =	0 μ s	0 μ s	001: Debounce time =	64 μ s	62.4 μ s	010: Debounce time =	128 μ s	125 μ s	011: Debounce time =	256 μ s	250 μ s	100: Debounce time =	512 μ s	500 μ s	101: Debounce time =	1024 μ s	1000 μ s	110: Debounce time =	2048 μ s	2000 μ s	111: Debounce time =	4096 μ s	4000 μ s
(1)	MCLK/DIV (Page 3/ Register 16) = 1-MHz Source	Internal Oscillator Source																												
000: Debounce time =	0 μ s	0 μ s																												
001: Debounce time =	64 μ s	62.4 μ s																												
010: Debounce time =	128 μ s	125 μ s																												
011: Debounce time =	256 μ s	250 μ s																												
100: Debounce time =	512 μ s	500 μ s																												
101: Debounce time =	1024 μ s	1000 μ s																												
110: Debounce time =	2048 μ s	2000 μ s																												
111: Debounce time =	4096 μ s	4000 μ s																												

(1) The clock used for the debounce has a clock period = debounce duration/8.

Page 3/Register 21: Threshold Check Flags Register

BIT	READ/ WRITE	RESET VALUE	DESCRIPTION
D7–D6	R/W	00	Reserved. Write only zeros to these bits.
D5 ⁽¹⁾	R/W	0	0: AUX1 measurement is less than programmed maximum threshold setting. 1: AUX1 measurement is greater than or equal to programmed maximum threshold setting.
D4 ⁽¹⁾	R/W	0	0: AUX1 measurement is greater than programmed minimum threshold setting. 1: AUX1 measurement is less than or equal to programmed minimum threshold setting.
D3 ⁽¹⁾	R/W	0	0: AUX2 measurement is less than programmed maximum threshold setting. 1: AUX2 measurement is greater than or equal to programmed maximum threshold setting.
D2 ⁽¹⁾	R/W	0	0: AUX2 measurement is greater than programmed minimum threshold setting. 1: AUX2 measurement is less than or equal to programmed minimum threshold setting.
D1 ⁽¹⁾	R/W	0	0: TEMP (TEMP1/TEMP2) measurement is less than programmed maximum threshold setting. 1: TEMP (TEMP1/TEMP2) measurement is greater than or equal to programmed maximum threshold setting.
D0 ⁽¹⁾	R/W	0	0: TEMP (TEMP1/TEMP2) measurement is greater than programmed minimum threshold setting. 1: TEMP (TEMP1/TEMP2) measurement is less than or equal to programmed minimum threshold setting.

(1) Sticky flag bits. These are read-only bits. They are automatically cleared once they are read and are set only if the source trigger occurs again.

Page 3/Register 22: AUX1 Maximum Value Check (MSB)

BIT	READ/ WRITE	RESET VALUE	DESCRIPTION
D7–D5	R/W	000	Reserved
D4	R/W	0	0: AUX1 maximum threshold check is disabled (valid for auto/non-auto scan measurement). 1: AUX1 maximum threshold check is enabled (valid for auto/non-auto scan measurement).
D3–D0	R/W	0000	AUX1 maximum threshold code 4 MSBs

Page 3/Register 23: AUX1 Maximum Value Check (LSB)

BIT	READ/ WRITE	RESET VALUE	DESCRIPTION
D7–D0	R/W	0000 0000	AUX1 maximum threshold code 8 LSBs

Page 3/Register 24: AUX1 Minimum Value Check (MSB)

BIT	READ/ WRITE	RESET VALUE	DESCRIPTION
D7–D5	R/W	000	Reserved
D4	R/W	0	0: AUX1 minimum threshold check is disabled (valid for auto/non-auto scan measurement). 1: AUX1 minimum threshold check is enabled (valid for auto/non-auto scan measurement).
D3–D0	R/W	0000	AUX1 minimum threshold code 4 MSBs

Page 3/Register 25: AUX1 Minimum Value Check (LSB)

BIT	READ/ WRITE	RESET VALUE	DESCRIPTION
D7–D0	R/W	0000 0000	AUX1 minimum threshold code 8 LSBs

Page 3/Register 26: AUX2 Maximum Value Check (MSB)

BIT	READ/ WRITE	RESET VALUE	DESCRIPTION
D7–D5	R/W	000	Reserved
D4	R/W	0	0: AUX2 maximum threshold check is disabled (valid for auto/non-auto scan measurement). 1: AUX2 maximum threshold check is enabled (valid for auto/non-auto scan measurement).
D3–D0	R/W	0000	AUX2 maximum threshold code 4 MSBs

Page 3/Register 27: AUX2 Maximum Value Check (LSB)

BIT	READ/ WRITE	RESET VALUE	DESCRIPTION
D7–D0	R/W	0000 0000	AUX2 maximum threshold code 8 LSBs

Page 3/Register 28: AUX2 Minimum Value Check (MSB)

BIT	READ/ WRITE	RESET VALUE	DESCRIPTION
D7–D5	R/W	000	Reserved
D4	R/W	0	0: AUX2 minimum threshold check is disabled (valid for auto/non-auto scan measurement). 1: AUX2 minimum threshold check is enabled (valid for auto/non-auto scan measurement).
D3–D0	R/W	0000	AUX2 minimum threshold code 4 MSBs

Page 3/Register 29: AUX2 Minimum Value Check (LSB)

BIT	READ/ WRITE	RESET VALUE	DESCRIPTION
D7–D0	R/W	0000 0000	AUX2 minimum threshold code 8 LSBs

Page 3/Register 30: Temperature Maximum Value Check (MSB)

BIT	READ/ WRITE	RESET VALUE	DESCRIPTION
D7–D5	R/W	000	Reserved. Write only zeros to these bits.
D4	R/W	0	0: TEMP (TEMP1/TEMP2) maximum threshold check is disabled (valid for auto/non-auto scan measurement). 1: TEMP (TEMP1/TEMP2) maximum threshold check is enabled (valid for auto/non-auto scan measurement).
D3–D0	R/W	0000	TEMP (TEMP1/TEMP2) maximum threshold code 4 MSBs

Page 3/Register 31: Temperature Maximum Value Check (LSB)

BIT	READ/ WRITE	RESET VALUE	DESCRIPTION
D7–D0	R/W	0000 0000	TEMP (TEMP1/TEMP2) maximum threshold code 8 LSBs

Page 3/Register 32: Temperature Minimum Value Check (MSB)

BIT	READ/ WRITE	RESET VALUE	DESCRIPTION
D7–D0	R/W	000	Reserved. Write only zeros to these bits.
D4	R/W	0	0: TEMP (TEMP1/TEMP2) minimum threshold check is disabled (valid for auto/non-auto scan measurement). 1: TEMP (TEMP1/TEMP2) minimum threshold check is enabled (valid for auto/non-auto scan measurement).
D3–D0	R/W	0000	TEMP (TEMP1/TEMP2) minimum threshold code 4 MSBs

Page 3/Register 33: Temperature Minimum Value Check (LSB)

BIT	READ/ WRITE	RESET VALUE	DESCRIPTION
D7–D0	R/W	0000 0000	TEMP (TEMP1/TEMP2) minimum threshold code 8 LSBs

Page 3/Registers 34 to 41: Reserved

BIT	READ/ WRITE	RESET VALUE	DESCRIPTION
D7–D0	R/W	XXXX XXXX	Reserved. Write only the reset value to these bits.

Page 3/Register 42: X-Coordinate Data (MSB)

BIT	READ/ WRITE	RESET VALUE	DESCRIPTION
D7–D0	R	0000 0000	Reading this register returns the 8 MSBs of the X-coordinate data.

Page 3/Register 43: X-Coordinate Data (LSB)

BIT	READ/ WRITE	RESET VALUE	DESCRIPTION
D7–D0	R	0000 0000	Reading this register returns the 8 LSBs of the X-coordinate data.

Page 3/Register 44: Y-Coordinate Data (MSB)

BIT	READ/ WRITE	RESET VALUE	DESCRIPTION
D7–D0	R	0000 0000	Reading this register returns the 8 MSBs of the Y-coordinate data.

Page 3/Register 45: Y-Coordinate Data (LSB)

BIT	READ/ WRITE	RESET VALUE	DESCRIPTION
D7–D0	R	0000 0000	Reading this register returns the 8 LSBs of the Y-coordinate data.

Page 3/Register 46: Z1 MSB Register

BIT	READ/ WRITE	RESET VALUE	DESCRIPTION
D7–D0	R	0000 0000	Reading this register returns the 8 MSBs of the Z1-coordinate data.

Page 3/Registers 47: Z1 LSB Register

BIT	READ/ WRITE	RESET VALUE	DESCRIPTION
D7–D0	R	0000 0000	Reading this register returns the 8 LSBs of the Z1-coordinate data.

Page 3/Registers 48: Z2 MSB Register

BIT	READ/ WRITE	RESET VALUE	DESCRIPTION
D7–D0	R	0000 0000	Reading this register returns the 8 MSBs of the Z2-coordinate data.

Page 3/Registers 49: Z2 LSB Register

BIT	READ/ WRITE	RESET VALUE	DESCRIPTION
D7–D0	R	0000 0000	Reading this register returns the 8 LSBs of the Z2-coordinate data.

Page 3/Registers 50 to 53: Reserved

BIT	READ/ WRITE	RESET VALUE	DESCRIPTION
D7–D0	R/W	XXXX XXXX	Reserved. Write only the reset value to these bits.

Page 3/Register 54: AUX1 Data (MSB)

BIT	READ/ WRITE	RESET VALUE	DESCRIPTION
D7–D0	R	0000 0000	Reading this register returns the 8 MSBs of the AUX1 data.

Page 3/Register 55: AUX1 Data (LSB)

BIT	READ/ WRITE	RESET VALUE	DESCRIPTION
D7–D0	R	0000 0000	Reading this register returns the 8 LSBs of the AUX1 data.

Page3/Register 56: AUX2 Data (MSB)

BIT	READ/ WRITE	RESET VALUE	DESCRIPTION
D7–D0	R	0000 0000	Reading this register returns the 8 MSBs of the AUX2 data.

Page 3/Register 57: AUX2 Data (LSB)

BIT	READ/ WRITE	RESET VALUE	DESCRIPTION
D7–D0	R	0000 0000	Reading this register returns the 8 LSBs of the AUX2 data.

Page 3/Register 58: VBAT Data (MSB)

BIT	READ/ WRITE	RESET VALUE	DESCRIPTION
D7–D0	R	0000 0000	Reading this register returns the 8 MSBs of the VBAT data.

Page 3/Register 59: VBAT Data (LSB)

BIT	READ/ WRITE	RESET VALUE	DESCRIPTION
D7–D0	R	0000 0000	Reading this register returns the 8 LSBs of the VBAT data.

Page 3/Registers 60 to 65: Reserved

BIT	READ/ WRITE	RESET VALUE	DESCRIPTION
D7–D0	R/W	XXXX XXXX	Reserved. Write only the reset value to these bits.

Page 3/Registers 66: TEMP1 MSB Data Register

BIT	READ/ WRITE	RESET VALUE	DESCRIPTION
D7–D0	R	0000 0000	Reading this register returns the 8 MSBs of TEMP1 data.

Page 3/Registers 67: TEMP1 LSB Data Register

BIT	READ/ WRITE	RESET VALUE	DESCRIPTION
D7–D0	R	0000 0000	Reading this register returns the 8 LSBs of TEMP1 data.

Page 3/Registers 68: TEMP2 MSB Data Register

BIT	READ/ WRITE	RESET VALUE	DESCRIPTION
D7–D0	R	0000 0000	Reading this register returns the 8 MSBs of TEMP2 data.

Page 3/Registers 69: TEMP2 LSB Data Register

BIT	READ/ WRITE	RESET VALUE	DESCRIPTION
D7–D0	R	0000 0000	Reading this register returns the 8 LSBs of TEMP2 data.

Page 3/Registers 70 to 127: Reserved

BIT	READ/ WRITE	RESET VALUE	DESCRIPTION
D7–D0	R/W	XXXX XXXX	Reserved. Write only the reset value to these bits.

6.5 Control Registers, Page 4: ADC Digital Filter Coefficients

Default values shown for this page only become valid 100 μ s following a hardware or software reset.

Page 4/Register 0: Page Control Register

BIT	READ/ WRITE	RESET VALUE	DESCRIPTION
D7–D0	R/W	0000 0000	0000 0000: Page 0 selected 0000 0001: Page 1 selected ... 1111 1110: Page 254 selected 1111 1111: Page 255 selected

The remaining page-4 registers are either reserved registers or are used for setting coefficients for the various filters in the TSC2117. Reserved registers should not be written to.

The filter coefficient registers are arranged in pairs, with two adjacent 8-bit registers containing the 16-bit coefficient for a single filter. The 16-bit integer contained in the MSB and LSB registers for a coefficient are interpreted as a 2s-complement integer, with possible values ranging from –32,768 to 32,767. When programming any coefficient value for a filter, the MSB register should always be written first, immediately followed by the LSB register. Even if only the MSB or LSB portion of the coefficient changes, both registers should be written in this sequence. [Table 6-3](#) is a list of the page-4 registers, excepting the previously described register 0.

Table 6-3. Page-4 Registers

REGISTER NUMBER	RESET VALUE	REGISTER NAME
1	XXXX XXXX	Reserved. Do not write to this register.
2	0000 0001	8 MSBs of N0 coefficient for AGC LPF (first-order IIR) used as averager to detect level or Coefficient C1(15:8) of ADC miniDSP
3	0001 0111	8 LSBs of N0 coefficient for AGC LPF (first-order IIR) used as averager to detect level or Coefficient C1(7:0) of ADC miniDSP
4	0000 0001	8 MSBs of N1 coefficient for AGC LPF (first-order IIR) used as averager to detect level or Coefficient C2(15:8) of ADC miniDSP
5	0001 0111	8 LSBs of N1 coefficient for AGC LPF (first-order IIR) used as averager to detect level or Coefficient C2(7:0) of ADC miniDSP
6	0111 1101	8 MSBs of D1 coefficient for AGC LPF (first-order IIR) used as averager to detect level or Coefficient C3(15:8) of ADC miniDSP
7	1101 0011	8 LSBs of D1 coefficient for AGC LPF (first-order IIR) used as averager to detect level or Coefficient C3(7:0) of ADC miniDSP
8	0111 1111	8 MSBs of N0 coefficient for ADC-programmable first-order IIR or Coefficient C4(15:8) of ADC miniDSP

Table 6-3. Page-4 Registers (continued)

REGISTER NUMBER	RESET VALUE	REGISTER NAME
9	1111 1111	8 LSBs of N0 coefficient for ADC-programmable first-order IIR or Coefficient C4(7:0) of ADC miniDSP
10	0000 0000	8 MSBs of N1 coefficient for ADC-programmable first-order IIR or Coefficient C5(15:8) of ADC miniDSP
11	0000 0000	8 LSBs of N1 coefficient for ADC-programmable first-order IIR or Coefficient C5(7:0) of ADC miniDSP
12	0000 0000	8 MSBs of D1 coefficient for ADC-programmable first-order IIR or Coefficient C6(15:8) of ADC miniDSP
13	0000 0000	8 LSBs of D1 coefficient for ADC-programmable first-order IIR or Coefficient C6(7:0) of ADC miniDSP
14	0111 1111	Coefficient N0(15:8) for ADC Biquad A or Coefficient FIR0(15:8) for ADC FIR Filter or Coefficient C7(15:8) of ADC miniDSP
15	1111 1111	Coefficient N0(7:0) for ADC Biquad A or Coefficient FIR0(7:0) for ADC FIR Filter or Coefficient C7(7:0) of ADC miniDSP
16	0000 0000	Coefficient N1(15:8) for ADC Biquad A or Coefficient FIR1(15:8) for ADC FIR Filter or Coefficient C8(15:8) of ADC miniDSP
17	0000 0000	Coefficient N1(7:0) for ADC Biquad A or Coefficient FIR1(7:0) for ADC FIR Filter or Coefficient C8(7:0) of ADC miniDSP
18	0000 0000	Coefficient N2(15:8) for ADC Biquad A or Coefficient FIR2(15:8) for ADC FIR Filter or Coefficient C9(15:8) of ADC miniDSP
19	0000 0000	Coefficient N2(7:0) for ADC Biquad A or Coefficient FIR2(7:0) for ADC FIR Filter or Coefficient C9(7:0) of ADC miniDSP
20	0000 0000	Coefficient D1(15:8) for ADC Biquad A or Coefficient FIR3(15:8) for ADC FIR Filter or Coefficient C10(15:8) of ADC miniDSP
21	0000 0000	Coefficient D1(7:0) for ADC Biquad A or Coefficient FIR3(7:0) for ADC FIR Filter or Coefficient C10(7:0) of ADC miniDSP
22	0000 0000	Coefficient D2(15:8) for ADC Biquad A or Coefficient FIR4(15:8) for ADC FIR Filter or Coefficient C11(15:8) of ADC miniDSP
23	0000 0000	Coefficient D2(7:0) for ADC Biquad A or Coefficient FIR4(7:0) for ADC FIR Filter or Coefficient C11(7:0) of ADC miniDSP
24	0111 1111	Coefficient N0(15:8) for ADC Biquad B or Coefficient FIR5(15:8) for ADC FIR Filter or Coefficient C12(15:8) of ADC miniDSP
25	1111 1111	Coefficient N0(7:0) for ADC Biquad B or Coefficient FIR5(7:0) for ADC FIR Filter or Coefficient C12(7:0) of ADC miniDSP
26	0000 0000	Coefficient N1(15:8) for ADC Biquad B or Coefficient FIR6(15:8) for ADC FIR Filter or Coefficient C13(15:8) of ADC miniDSP
27	0000 0000	Coefficient N1(7:0) for ADC Biquad B or Coefficient FIR6(7:0) for ADC FIR Filter or Coefficient C13(7:0) of ADC miniDSP
28	0000 0000	Coefficient N2(15:8) for ADC Biquad B or Coefficient FIR7(15:8) for ADC FIR Filter or Coefficient C14(15:8) of ADC miniDSP
29	0000 0000	Coefficient N2(7:0) for ADC Biquad B or Coefficient FIR7(7:0) for ADC FIR Filter or Coefficient C14(7:0) of ADC miniDSP
30	0000 0000	Coefficient D1(15:8) for ADC Biquad B or Coefficient FIR8(15:8) for ADC FIR Filter or Coefficient C15(15:8) of ADC miniDSP
31	0000 0000	Coefficient D1(7:0) for ADC Biquad B or Coefficient FIR8(7:0) for ADC FIR Filter or Coefficient C15(7:0) of ADC miniDSP
32	0000 0000	Coefficient D2(15:8) for ADC Biquad B or Coefficient FIR9(15:8) for ADC FIR Filter or Coefficient C16(15:8) of ADC miniDSP
33	0000 0000	Coefficient D2(7:0) for ADC Biquad B or Coefficient FIR9(7:0) for ADC FIR Filter or Coefficient C16(7:0) of ADC miniDSP
34	0111 1111	Coefficient N0(15:8) for ADC Biquad C or Coefficient FIR10(15:8) for ADC FIR Filter or Coefficient C17(15:8) of ADC miniDSP
35	1111 1111	Coefficient N0(7:0) for ADC Biquad C or Coefficient FIR10(7:0) for ADC FIR Filter or Coefficient C17(7:0) of ADC miniDSP

Table 6-3. Page-4 Registers (continued)

REGISTER NUMBER	RESET VALUE	REGISTER NAME
36	0000 0000	Coefficient N1(15:8) for ADC Biquad C or Coefficient FIR11(15:8) for ADC FIR Filter or Coefficient C18(15:8) of ADC miniDSP
37	0000 0000	Coefficient N1(7:0) for ADC Biquad C or Coefficient FIR11(7:0) for ADC FIR Filter or Coefficient C18(7:0) of ADC miniDSP
38	0000 0000	Coefficient N2(15:8) for ADC Biquad C or Coefficient FIR12(15:8) for ADC FIR Filter or Coefficient C19(15:8) of ADC miniDSP
39	0000 0000	Coefficient N2(7:0) for ADC Biquad C or Coefficient FIR12(7:0) for ADC FIR Filter or Coefficient C19(7:0) of ADC miniDSP
40	0000 0000	Coefficient D1(15:8) for ADC Biquad C or Coefficient FIR13(15:8) for ADC FIR Filter or Coefficient C20(15:8) of ADC miniDSP
41	0000 0000	Coefficient D1(7:0) for ADC Biquad C or Coefficient FIR13(7:0) for ADC FIR Filter or Coefficient C20(7:0) of ADC miniDSP
42	0000 0000	Coefficient D2(15:8) for ADC Biquad C or Coefficient FIR14(15:8) for ADC FIR Filter or Coefficient C21(15:8) of ADC miniDSP
43	0000 0000	Coefficient D2(7:0) for ADC Biquad C or Coefficient FIR14(7:0) for ADC FIR Filter or Coefficient C21(7:0) of ADC miniDSP
44	0111 1111	Coefficient N0(15:8) for ADC Biquad D or Coefficient FIR15(15:8) for ADC FIR Filter or Coefficient C22(15:8) of ADC miniDSP
45	1111 1111	Coefficient N0(7:0) for ADC Biquad D or Coefficient FIR15(7:0) for ADC FIR Filter or Coefficient C22(7:0) of ADC miniDSP
46	0000 0000	Coefficient N1(15:8) for ADC Biquad D or Coefficient FIR16(15:8) for ADC FIR Filter or Coefficient C23(15:8) of ADC miniDSP
47	0000 0000	Coefficient N1(7:0) for ADC Biquad D or Coefficient FIR16(7:0) for ADC FIR Filter or Coefficient C23(7:0) of ADC miniDSP
48	0000 0000	Coefficient N2(15:8) for ADC Biquad D or Coefficient FIR17(15:8) for ADC FIR Filter or Coefficient C24(15:8) of ADC miniDSP
49	0000 0000	Coefficient N2(7:0) for ADC Biquad D or Coefficient FIR17(7:0) for ADC FIR Filter or Coefficient C24(7:0) of ADC miniDSP
50	0000 0000	Coefficient D1(15:8) for ADC Biquad D or Coefficient FIR18(15:8) for ADC FIR Filter or Coefficient C25(15:8) of ADC miniDSP
51	0000 0000	Coefficient D1(7:0) for ADC Biquad D or Coefficient FIR18(7:0) for ADC FIR Filter or Coefficient C25(7:0) of ADC miniDSP
52	0000 0000	Coefficient D2(15:8) for ADC Biquad D or Coefficient FIR19(15:8) for ADC FIR Filter or Coefficient C26(15:8) of ADC miniDSP
53	0000 0000	Coefficient D2(7:0) for ADC Biquad D or Coefficient FIR19(7:0) for ADC FIR Filter or Coefficient C26(7:0) of ADC miniDSP
54	0111 1111	Coefficient N0(15:8) for ADC Biquad E or Coefficient FIR20(15:8) for ADC FIR Filter or Coefficient C27(15:8) of ADC miniDSP
55	1111 1111	Coefficient N0(7:0) for ADC Biquad E or Coefficient FIR20(7:0) for ADC FIR Filter or Coefficient C27(7:0) of ADC miniDSP
56	0000 0000	Coefficient N1(15:8) for ADC Biquad E or Coefficient FIR21(15:8) for ADC FIR Filter or Coefficient C28(15:8) of ADC miniDSP
57	0000 0000	Coefficient N1(7:0) for ADC Biquad E or Coefficient FIR21(7:0) for ADC FIR Filter or Coefficient C28(7:0) of ADC miniDSP
58	0000 0000	Coefficient N2(15:8) for ADC Biquad E or Coefficient FIR22(15:8) for ADC FIR Filter or Coefficient C29(15:8) of ADC miniDSP
59	0000 0000	Coefficient N2(7:0) for ADC Biquad E or Coefficient FIR22(7:0) for ADC FIR Filter or Coefficient C29(7:0) of ADC miniDSP
60	0000 0000	Coefficient D1(15:8) for ADC Biquad E or Coefficient FIR23(15:8) for ADC FIR Filter or Coefficient C30(15:8) of ADC miniDSP
61	0000 0000	Coefficient D1(7:0) for ADC Biquad E or Coefficient FIR23(7:0) for ADC FIR Filter or Coefficient C30(7:0) of ADC miniDSP
62	0000 0000	Coefficient D2(15:8) for ADC Biquad E or Coefficient FIR24(15:8) for ADC FIR Filter or Coefficient C31(15:8) of ADC miniDSP

Table 6-3. Page-4 Registers (continued)

REGISTER NUMBER	RESET VALUE	REGISTER NAME
63	0000 0000	Coefficient D2(7:0) for ADC Biquad E or Coefficient FIR24(7:0) for ADC FIR Filter or Coefficient C31(7:0) of ADC miniDSP
64	0000 0000	Coefficient C32(15:8) of ADC miniDSP
65	0000 0000	Coefficient C32(7:0) of ADC miniDSP
66	0000 0000	Coefficient C33(15:8) of ADC miniDSP
67	0000 0000	Coefficient C33(7:0) of ADC miniDSP
68	0000 0000	Coefficient C34(15:8) of ADC miniDSP
69	0000 0000	Coefficient C34(7:0) of ADC miniDSP
70	0000 0000	Coefficient C35(15:8) of ADC miniDSP
71	0000 0000	Coefficient C35(7:0) of ADC miniDSP
72	0000 0000	Coefficient C36(15:8) of ADC miniDSP
73	0000 0000	Coefficient C36(7:0) of ADC miniDSP
74	0000 0000	Coefficient C37(15:8) of ADC miniDSP
75	0000 0000	Coefficient C37(7:0) of ADC miniDSP
76	0000 0000	Coefficient C38(15:8) of ADC miniDSP
77	0000 0000	Coefficient C38(7:0) of ADC miniDSP
78	0000 0000	Coefficient C39(15:8) of ADC miniDSP
79	0000 0000	Coefficient C39(7:0) of ADC miniDSP
80	0000 0000	Coefficient C40(15:8) of ADC miniDSP
81	0000 0000	Coefficient C40(7:0) of ADC miniDSP
82	0000 0000	Coefficient C41(15:8) of ADC miniDSP
83	0000 0000	Coefficient C41(7:0) of ADC miniDSP
84	0000 0000	Coefficient C42(15:8) of ADC miniDSP
85	0000 0000	Coefficient C42(7:0) of ADC miniDSP
86	0000 0000	Coefficient C43(15:8) of ADC miniDSP
87	0000 0000	Coefficient C43(7:0) of ADC miniDSP
88	0000 0000	Coefficient C44(15:8) of ADC miniDSP
89	0000 0000	Coefficient C44(7:0) of ADC miniDSP
90	0000 0000	Coefficient C45(15:8) of ADC miniDSP
91	0000 0000	Coefficient C45(7:0) of ADC miniDSP
92	0000 0000	Coefficient C46(15:8) of ADC miniDSP
93	0000 0000	Coefficient C46(7:0) of ADC miniDSP
94	0000 0000	Coefficient C47(15:8) of ADC miniDSP
95	0000 0000	Coefficient C47(7:0) of ADC miniDSP
96	0000 0000	Coefficient C48(15:8) of ADC miniDSP
97	0000 0000	Coefficient C48(7:0) of ADC miniDSP
98	0000 0000	Coefficient C49(15:8) of ADC miniDSP
99	0000 0000	Coefficient C49(7:0) of ADC miniDSP
100	0000 0000	Coefficient C50(15:8) of ADC miniDSP
101	0000 0000	Coefficient C50(7:0) of ADC miniDSP
102	0000 0000	Coefficient C51(15:8) of ADC miniDSP
103	0000 0000	Coefficient C51(7:0) of ADC miniDSP
104	0000 0000	Coefficient C52(15:8) of ADC miniDSP
105	0000 0000	Coefficient C52(7:0) of ADC miniDSP
106	0000 0000	Coefficient C53(15:8) of ADC miniDSP
107	0000 0000	Coefficient C53(7:0) of ADC miniDSP
108	0000 0000	Coefficient C54(15:8) of ADC miniDSP

Table 6-3. Page-4 Registers (continued)

REGISTER NUMBER	RESET VALUE	REGISTER NAME
109	0000 0000	Coefficient C54(7:0) of ADC miniDSP
110	0000 0000	Coefficient C55(15:8) of ADC miniDSP
111	0000 0000	Coefficient C55(7:0) of ADC miniDSP
112	0000 0000	Coefficient C56(15:8) of ADC miniDSP
113	0000 0000	Coefficient C56(7:0) of ADC miniDSP
114	0000 0000	Coefficient C57(15:8) of ADC miniDSP
115	0000 0000	Coefficient C57(7:0) of ADC miniDSP
116	0000 0000	Coefficient C58(15:8) of ADC miniDSP
117	0000 0000	Coefficient C58(7:0) of ADC miniDSP
118	0000 0000	Coefficient C59(15:8) of ADC miniDSP
119	0000 0000	Coefficient C59(7:0) of ADC miniDSP
120	0000 0000	Coefficient C60(15:8) of ADC miniDSP
121	0000 0000	Coefficient C60(7:0) of ADC miniDSP
122	0000 0000	Coefficient C61(15:8) of ADC miniDSP
123	0000 0000	Coefficient C61(7:0) of ADC miniDSP
124	0000 0000	Coefficient C62(15:8) of ADC miniDSP
125	0000 0000	Coefficient C62(7:0) of ADC miniDSP
126	0000 0000	Coefficient C63(15:8) of ADC miniDSP
127	0000 0000	Coefficient C63(7:0) of ADC miniDSP

6.6 Control Registers, Page 5: ADC Programmable Coefficients RAM (65:127)**Table 6-4. Page-5 Registers**

REGISTER NUMBER	RESET VALUE	REGISTER NAME
1	XXXX XXXX	Reserved. Do not write to this register.
2	0000 0000	Coefficient C65(15:8) of ADC miniDSP
3	0000 0000	Coefficient C65(7:0) of ADC miniDSP
4	0000 0000	Coefficient C66(15:8) of ADC miniDSP
5	0000 0000	Coefficient C66(7:0) of ADC miniDSP
6	0000 0000	Coefficient C67(15:8) of ADC miniDSP
7	0000 0000	Coefficient C67(7:0) of ADC miniDSP
8	0000 0000	Coefficient C68(15:8) of ADC miniDSP
9	0000 0000	Coefficient C68(7:0) of ADC miniDSP
10	0000 0000	Coefficient C69(15:8) of ADC miniDSP
11	0000 0000	Coefficient C69(7:0) of ADC miniDSP
12	0000 0000	Coefficient C70(15:8) of ADC miniDSP
13	0000 0000	Coefficient C70(7:0) of ADC miniDSP
14	0000 0000	Coefficient C71(15:8) of ADC miniDSP
15	0000 0000	Coefficient C71(7:0) of ADC miniDSP
16	0000 0000	Coefficient C72(15:8) of ADC miniDSP
17	0000 0000	Coefficient C72(7:0) of ADC miniDSP
18	0000 0000	Coefficient C73(15:8) of ADC miniDSP
19	0000 0000	Coefficient C73(7:0) of ADC miniDSP
20	0000 0000	Coefficient C74(15:8) of ADC miniDSP

Table 6-4. Page-5 Registers (continued)

REGISTER NUMBER	RESET VALUE	REGISTER NAME
21	0000 0000	Coefficient C74(7:0) of ADC miniDSP
22	0000 0000	Coefficient C75(15:8) of ADC miniDSP
23	0000 0000	Coefficient C75(7:0) of ADC miniDSP
24	0000 0000	Coefficient C76(15:8) of ADC miniDSP
25	0000 0000	Coefficient C76(7:0) of ADC miniDSP
26	0000 0000	Coefficient C77(15:8) of ADC miniDSP
27	0000 0000	Coefficient C77(7:0) of ADC miniDSP
28	0000 0000	Coefficient C78(15:8) of ADC miniDSP
29	0000 0000	Coefficient C78(7:0) of ADC miniDSP
30	0000 0000	Coefficient C79(15:8) of ADC miniDSP
31	0000 0000	Coefficient C79(7:0) of ADC miniDSP
32	0000 0000	Coefficient C80(15:8) of ADC miniDSP
33	0000 0000	Coefficient C80(7:0) of ADC miniDSP
34	0000 0000	Coefficient C81(15:8) of ADC miniDSP
35	0000 0000	Coefficient C81(7:0) of ADC miniDSP
36	0000 0000	Coefficient C82(15:8) of ADC miniDSP
37	0000 0000	Coefficient C82(7:0) of ADC miniDSP
38	0000 0000	Coefficient C83(15:8) of ADC miniDSP
39	0000 0000	Coefficient C83(7:0) of ADC miniDSP
40	0000 0000	Coefficient C84(15:8) of ADC miniDSP
41	0000 0000	Coefficient C84(7:0) of ADC miniDSP
42	0000 0000	Coefficient C85(15:8) of ADC miniDSP
43	0000 0000	Coefficient C85(7:0) of ADC miniDSP
44	0000 0000	Coefficient C86(15:8) of ADC miniDSP
45	0000 0000	Coefficient C86(7:0) of ADC miniDSP
46	0000 0000	Coefficient C87(15:8) of ADC miniDSP
47	0000 0000	Coefficient C87(7:0) of ADC miniDSP
48	0000 0000	Coefficient C88(15:8) of ADC miniDSP
49	0000 0000	Coefficient C88(7:0) of ADC miniDSP
50	0000 0000	Coefficient C89(15:8) of ADC miniDSP
51	0000 0000	Coefficient C89(7:0) of ADC miniDSP
52	0000 0000	Coefficient C90(15:8) of ADC miniDSP
53	0000 0000	Coefficient C90(7:0) of ADC miniDSP
54	0000 0000	Coefficient C91(15:8) of ADC miniDSP
55	0000 0000	Coefficient C91(7:0) of ADC miniDSP
56	0000 0000	Coefficient C92(15:8) of ADC miniDSP
57	0000 0000	Coefficient C92(7:0) of ADC miniDSP
58	0000 0000	Coefficient C93(15:8) of ADC miniDSP
59	0000 0000	Coefficient C93(7:0) of ADC miniDSP
60	0000 0000	Coefficient C94(15:8) of ADC miniDSP
61	0000 0000	Coefficient C94(7:0) of ADC miniDSP
62	0000 0000	Coefficient C95(15:8) of ADC miniDSP
63	0000 0000	Coefficient C95(7:0) of ADC miniDSP
64	0000 0000	Coefficient C96(15:8) of ADC miniDSP
65	0000 0000	Coefficient C96(7:0) of ADC miniDSP
66	0000 0000	Coefficient C97(15:8) of ADC miniDSP
67	0000 0000	Coefficient C97(7:0) of ADC miniDSP

Table 6-4. Page-5 Registers (continued)

REGISTER NUMBER	RESET VALUE	REGISTER NAME
68	0000 0000	Coefficient C98(15:8) of ADC miniDSP
69	0000 0000	Coefficient C98(7:0) of ADC miniDSP
70	0000 0000	Coefficient C99(15:8) of ADC miniDSP
71	0000 0000	Coefficient C99(7:0) of ADC miniDSP
72	0000 0000	Coefficient C100(15:8) of ADC miniDSP
73	0000 0000	Coefficient C100(7:0) of ADC miniDSP
74	0000 0000	Coefficient C101(15:8) of ADC miniDSP
75	0000 0000	Coefficient C101(7:0) of ADC miniDSP
76	0000 0000	Coefficient C102(15:8) of ADC miniDSP
77	0000 0000	Coefficient C102(7:0) of ADC miniDSP
78	0000 0000	Coefficient C103(15:8) of ADC miniDSP
79	0000 0000	Coefficient C103(7:0) of ADC miniDSP
80	0000 0000	Coefficient C104(15:8) of ADC miniDSP
81	0000 0000	Coefficient C104(7:0) of ADC miniDSP
82	0000 0000	Coefficient C105(15:8) of ADC miniDSP
83	0000 0000	Coefficient C105(7:0) of ADC miniDSP
84	0000 0000	Coefficient C106(15:8) of ADC miniDSP
85	0000 0000	Coefficient C106(7:0) of ADC miniDSP
86	0000 0000	Coefficient C107(15:8) of ADC miniDSP
87	0000 0000	Coefficient C107(7:0) of ADC miniDSP
88	0000 0000	Coefficient C108(15:8) of ADC miniDSP
89	0000 0000	Coefficient C108(7:0) of ADC miniDSP
90	0000 0000	Coefficient C109(15:8) of ADC miniDSP
91	0000 0000	Coefficient C109(7:0) of ADC miniDSP
92	0000 0000	Coefficient C110(15:8) of ADC miniDSP
93	0000 0000	Coefficient C110(7:0) of ADC miniDSP
94	0000 0000	Coefficient C111(15:8) of ADC miniDSP
95	0000 0000	Coefficient C111(7:0) of ADC miniDSP
96	0000 0000	Coefficient C112(15:8) of ADC miniDSP
97	0000 0000	Coefficient C112(7:0) of ADC miniDSP
98	0000 0000	Coefficient C113(15:8) of ADC miniDSP
99	0000 0000	Coefficient C113(7:0) of ADC miniDSP
100	0000 0000	Coefficient C114(15:8) of ADC miniDSP
101	0000 0000	Coefficient C114(7:0) of ADC miniDSP
102	0000 0000	Coefficient C115(15:8) of ADC miniDSP
103	0000 0000	Coefficient C115(7:0) of ADC miniDSP
104	0000 0000	Coefficient C117(15:8) of ADC miniDSP
105	0000 0000	Coefficient C117(7:0) of ADC miniDSP
106	0000 0000	Coefficient C117(15:8) of ADC miniDSP
107	0000 0000	Coefficient C117(7:0) of ADC miniDSP
108	0000 0000	Coefficient C118(15:8) of ADC miniDSP
109	0000 0000	Coefficient C118(7:0) of ADC miniDSP
110	0000 0000	Coefficient C119(15:8) of ADC miniDSP
111	0000 0000	Coefficient C119(7:0) of ADC miniDSP
112	0000 0000	Coefficient C120(15:8) of ADC miniDSP
113	0000 0000	Coefficient C120(7:0) of ADC miniDSP
114	0000 0000	Coefficient C121(15:8) of ADC miniDSP

Table 6-4. Page-5 Registers (continued)

REGISTER NUMBER	RESET VALUE	REGISTER NAME
115	0000 0000	Coefficient C121(7:0) of ADC miniDSP
116	0000 0000	Coefficient C122(15:8) of ADC miniDSP
117	0000 0000	Coefficient C122(7:0) of ADC miniDSP
118	0000 0000	Coefficient C123(15:8) of ADC miniDSP
119	0000 0000	Coefficient C123(7:0) of ADC miniDSP
120	0000 0000	Coefficient C124(15:8) of ADC miniDSP
121	0000 0000	Coefficient C124(7:0) of ADC miniDSP
122	0000 0000	Coefficient C125(15:8) of ADC miniDSP
123	0000 0000	Coefficient C125(7:0) of ADC miniDSP
124	0000 0000	Coefficient C126(15:8) of ADC miniDSP
125	0000 0000	Coefficient C126(7:0) of ADC miniDSP
126	0000 0000	Coefficient C127(15:8) of ADC miniDSP
127	0000 0000	Coefficient C127(7:0) of ADC miniDSP

6.7 Control Registers, Page 8: DAC Digital Filter Coefficients

Default values shown for this page only become valid 100 μ s following a hardware or software reset.

Page 8/Register 0: Page Control Register

BIT	READ/ WRITE	RESET VALUE	DESCRIPTION
D7–D0	R/W	0000 0000	0000 0000: Page 0 selected 0000 0001: Page 1 selected ... 1111 1110: Page 254 selected 1111 1111: Page 255 selected

The remaining page-8 registers are either reserved registers or are used for setting coefficients for the various filters in the TSC2117. Reserved registers should not be written to.

The filter coefficient registers are arranged in pairs, with two adjacent 8-bit registers containing the 16-bit coefficient for a single filter. The 16-bit integer contained in the MSB and LSB registers for a coefficient are interpreted as a 2s-complement integer, with possible values ranging from –32,768 to 32,767. When programming any coefficient value for a filter, the MSB register should always be written first, immediately followed by the LSB register. Even if only the MSB or LSB portion of the coefficient changes, both registers should be written in this sequence. [Table 6-5](#) is a list of the page-8 registers, excepting the previously described register 0.

Page 8/Register 1: DAC Coefficient RAM Control

BIT	READ/ WRITE	RESET VALUE	DESCRIPTION
D7–D4	R/W	00000	Reserved. Write only the reset value.
D3	R	0	DAC miniDSP generated flag for toggling MSB of coefficient RAM address (only used in non-adaptive mode)
D2	R/W	0	DAC Adaptive Filtering Control 0: Adaptive filtering disabled in DAC miniDSP 1: Adaptive filtering enabled in DAC miniDSP
D1	R	0	DAC Adaptive Filter Buffer Control Flag 0: In adaptive filter mode, DAC miniDSP accesses DAC coefficient Buffer A and the external control interface accesses DAC coefficient Buffer B 1: In adaptive filter mode, DAC miniDSP accesses DAC coefficient Buffer B and the external control interface accesses DAC coefficient Buffer A
D0	R/W	0	DAC Adaptive Filter Buffer Switch Control 0: DAC coefficient buffers will not be switched at the next frame boundary 1: DAC coefficient buffers will be switched at the next frame boundary, if adaptive filtering mode is enabled. This bit will self-clear on switching.

Table 6-5. Page 8 Registers

REGISTER NUMBER	RESET VALUE	REGISTER NAME
2	0111 1111	8 MSBs of n0 coefficient for left DAC-programmable biquad A or Coefficient C1(15:8) of DAC miniDSP (DAC Buffer A)
3	1111 1111	8 LSBs of n0 coefficient for left DAC-programmable biquad A or Coefficient C1(7:0) of DAC miniDSP (DAC Buffer A)
4	0000 0000	8 MSBs of n1 coefficient for left DAC-programmable biquad A or Coefficient C2(15:8) of DAC miniDSP (DAC Buffer A)
5	0000 0000	8 LSBs of n1 coefficient for left DAC-programmable biquad A or Coefficient C2(7:0) of DAC miniDSP (DAC Buffer A)
6	0000 0000	8 MSBs of n2 coefficient for left DAC-programmable biquad A or Coefficient C3(15:8) of DAC miniDSP (DAC Buffer A)
7	0000 0000	8 LSBs of n2 coefficient for left DAC-programmable biquad A or Coefficient C3(7:0) of DAC miniDSP (DAC Buffer A)
8	0000 0000	8 MSBs of d1 coefficient for left DAC-programmable biquad A or Coefficient C4(15:8) of DAC miniDSP (DAC Buffer A)
9	0000 0000	8 LSBs of d1 coefficient for left DAC-programmable biquad A or Coefficient C4(7:0) of DAC miniDSP (DAC Buffer A)
10	0000 0000	8 MSBs of d2 coefficient for left DAC-programmable biquad A or Coefficient C5(15:8) of DAC miniDSP (DAC Buffer A)
11	0000 0000	8 LSBs of d2 coefficient for left DAC-programmable biquad A or Coefficient C5(7:0) of DAC miniDSP (DAC Buffer A)
12	0111 1111	8 MSBs of n0 coefficient for left DAC-programmable biquad B or Coefficient C6(15:8) of DAC miniDSP (DAC Buffer A)
13	1111 1111	8 LSBs of n0 coefficient for left DAC-programmable biquad B or Coefficient C6(7:0) of DAC miniDSP (DAC Buffer A)
14	0000 0000	8 MSBs of n1 coefficient for left DAC-programmable biquad B or Coefficient C7(15:8) of DAC miniDSP (DAC Buffer A)
15	0000 0000	8 LSBs of n1 coefficient for left DAC-programmable biquad B or Coefficient C7(7:0) of DAC miniDSP (DAC Buffer A)
16	0000 0000	8 MSBs of n2 coefficient for left DAC-programmable biquad B or Coefficient C8(15:8) of DAC miniDSP (DAC Buffer A)
17	0000 0000	8 LSBs of n2 coefficient for left DAC-programmable biquad B or Coefficient C8(7:0) of DAC miniDSP (DAC Buffer A)
18	0000 0000	8 MSBs of d1 coefficient for left DAC-programmable biquad B or Coefficient C9(15:8) of DAC miniDSP (DAC Buffer A)
19	0000 0000	8 LSBs of d1 coefficient for left DAC-programmable biquad B or Coefficient C9(7:0) of DAC miniDSP (DAC Buffer A)

Table 6-5. Page 8 Registers (continued)

REGISTER NUMBER	RESET VALUE	REGISTER NAME
20	0000 0000	8 MSBs of d2 coefficient for left DAC-programmable biquad B or Coefficient C10(15:8) of DAC miniDSP (DAC Buffer A)
21	0000 0000	8 LSBs of d2 coefficient for left DAC-programmable biquad B or Coefficient C10(7:0) of DAC miniDSP (DAC Buffer A)
22	0111 1111	8 MSBs of n0 coefficient for left DAC-programmable biquad C or Coefficient C11(15:8) of DAC miniDSP (DAC Buffer A)
23	1111 1111	8 LSBs of n0 coefficient for left DAC-programmable biquad C or Coefficient C11(7:0) of DAC miniDSP (DAC Buffer A)
24	0000 0000	8 MSBs of n1 coefficient for left DAC-programmable biquad C or Coefficient C12(15:8) of DAC miniDSP (DAC Buffer A)
25	0000 0000	8 LSBs of n1 coefficient for left DAC-programmable biquad C or Coefficient C12(7:0) of DAC miniDSP (DAC Buffer A)
26	0000 0000	8 MSBs of n2 coefficient for left DAC-programmable biquad C or Coefficient C13(15:8) of DAC miniDSP (DAC Buffer A)
27	0000 0000	8 LSBs of n2 coefficient for left DAC-programmable biquad C or Coefficient C13(7:0) of DAC miniDSP (DAC Buffer A)
28	0000 0000	8 MSBs of d1 coefficient for left DAC-programmable biquad C or Coefficient C14(15:8) of DAC miniDSP (DAC Buffer A)
29	0000 0000	8 LSBs of d1 coefficient for left DAC-programmable biquad C or Coefficient C14(7:0) of DAC miniDSP (DAC Buffer A)
30	0000 0000	8 MSBs of d2 coefficient for left DAC-programmable biquad C or Coefficient C15(15:8) of DAC miniDSP (DAC Buffer A)
31	0000 0000	8 LSBs of d2 coefficient for left DAC-programmable biquad C or Coefficient C15(7:0) of DAC miniDSP (DAC Buffer A)
32	0111 1111	8 MSBs of n0 coefficient for left DAC-programmable biquad D or Coefficient C16(15:8) of DAC miniDSP (DAC Buffer A)
33	1111 1111	8 LSBs of n0 coefficient for left DAC-programmable biquad D or Coefficient C16(7:0) of DAC miniDSP (DAC Buffer A)
34	0000 0000	8 MSBs of n1 coefficient for left DAC-programmable biquad D or Coefficient C17(15:8) of DAC miniDSP (DAC Buffer A)
35	0000 0000	8 LSBs of n1 coefficient for left DAC-programmable biquad D or Coefficient C17(7:0) of DAC miniDSP (DAC Buffer A)
36	0000 0000	8 MSBs of n2 coefficient for left DAC-programmable biquad D or Coefficient C18(15:8) of DAC miniDSP (DAC Buffer A)
37	0000 0000	8 LSBs of n2 coefficient for left DAC-programmable biquad D or Coefficient C18(7:0) of DAC miniDSP (DAC Buffer A)
38	0000 0000	8 MSBs of d1 coefficient for left DAC-programmable biquad D or Coefficient C19(15:8) of DAC miniDSP (DAC Buffer A)
39	0000 0000	8 LSBs of d1 coefficient for left DAC-programmable biquad D or Coefficient C19(7:0) of DAC miniDSP (DAC Buffer A)
40	0000 0000	8 MSBs of d2 coefficient for left DAC-programmable biquad D or Coefficient C20(15:8) of DAC miniDSP (DAC Buffer A)
41	0000 0000	8 LSBs of d2 coefficient for left DAC-programmable biquad D or Coefficient C20(7:0) of DAC miniDSP (DAC Buffer A)
42	0111 1111	8 MSBs of n0 coefficient for left DAC-programmable biquad E or Coefficient C21(15:8) of DAC miniDSP (DAC Buffer A)
43	1111 1111	8 LSBs of n0 coefficient for left DAC-programmable biquad E or Coefficient C21(7:0) of DAC miniDSP (DAC Buffer A)
44	0000 0000	8 MSBs of n1 coefficient for left DAC-programmable biquad E or Coefficient C22(15:8) of DAC miniDSP (DAC Buffer A)
45	0000 0000	8 LSBs of n1 coefficient for left DAC-programmable biquad E or Coefficient C22(7:0) of DAC miniDSP (DAC Buffer A)
46	0000 0000	8 MSBs of n2 coefficient for left DAC-programmable biquad E or Coefficient C23(15:8) of DAC miniDSP (DAC Buffer A)

Table 6-5. Page 8 Registers (continued)

REGISTER NUMBER	RESET VALUE	REGISTER NAME
47	0000 0000	8 LSBs of n2 coefficient for left DAC-programmable biquad E or Coefficient C23(7:0) of DAC miniDSP (DAC Buffer A)
48	0000 0000	8 MSBs of d1 coefficient for left DAC-programmable biquad E or Coefficient C24(15:8) of DAC miniDSP (DAC Buffer A)
49	0000 0000	8 LSBs of d1 coefficient for left DAC-programmable biquad E or Coefficient C24(7:0) of DAC miniDSP (DAC Buffer A)
50	0000 0000	8 MSBs of d2 coefficient for left DAC-programmable biquad E or Coefficient C25(15:8) of DAC miniDSP (DAC Buffer A)
51	0000 0000	8 LSBs of d2 coefficient for left DAC-programmable biquad E or Coefficient C25(7:0) of DAC miniDSP (DAC Buffer A)
52	0111 1111	8 MSBs of n0 coefficient for left DAC-programmable biquad F or Coefficient C26(15:8) of DAC miniDSP (DAC Buffer A)
53	1111 1111	8 LSBs of n0 coefficient for left DAC-programmable biquad F or Coefficient C26(7:0) of DAC miniDSP (DAC Buffer A)
54	0000 0000	8 MSBs of n1 coefficient for left DAC-programmable biquad F or Coefficient C27(15:8) of DAC miniDSP (DAC Buffer A)
55	0000 0000	8 LSBs of n1 coefficient for left DAC-programmable biquad F or Coefficient C27(7:0) of DAC miniDSP (DAC Buffer A)
56	0000 0000	8 MSBs of n2 coefficient for left DAC-programmable biquad F or Coefficient C28(15:8) of DAC miniDSP (DAC Buffer A)
57	0000 0000	8 LSBs of n2 coefficient for left DAC-programmable biquad F or Coefficient C28(7:0) of DAC miniDSP (DAC Buffer A)
58	0000 0000	8 MSBs of d1 coefficient for left DAC-programmable biquad F or Coefficient C29(15:8) of DAC miniDSP (DAC Buffer A)
59	0000 0000	8 LSBs of d1 coefficient for left DAC-programmable biquad F or Coefficient C29(7:0) of DAC miniDSP (DAC Buffer A)
60	0000 0000	8 MSBs of d2 coefficient for left DAC-programmable biquad F or Coefficient C30(15:8) of DAC miniDSP (DAC Buffer A)
61	0000 0000	8 LSBs of d2 coefficient for left DAC-programmable biquad F or Coefficient C30(7:0) of DAC miniDSP (DAC Buffer A)
62	0000 0000	Coefficient C31(15:8) of DAC miniDSP (DAC Buffer A)
63	0000 0000	Coefficient C31(7:0) of DAC miniDSP (DAC Buffer A)
64	0000 0000	Coefficient C32(15:8) of DAC miniDSP (DAC Buffer A)—also used for the 3D PGA for PRB_P23, PRB_P24 and PRB_P25
65	0000 0000	Coefficient C32(7:0) of DAC miniDSP (DAC Buffer A)—also used for the 3D PGA for PRB_P23, PRB_P24 and PRB_P25
66	0111 1111	8 MSBs of n0 coefficient for right DAC-programmable biquad A or Coefficient C33(15:8) of DAC miniDSP (DAC Buffer A)
67	1111 1111	8 LSBs of n0 coefficient for right DAC-programmable biquad A or Coefficient C33(7:0) of DAC miniDSP (DAC Buffer A)
68	0000 0000	8 MSBs of n1 coefficient for right DAC-programmable biquad A or Coefficient C34(15:8) of DAC miniDSP (DAC Buffer A)
69	0000 0000	8 LSBs of n1 coefficient for right DAC-programmable biquad A or Coefficient C34(7:0) of DAC miniDSP (DAC Buffer A)
70	0000 0000	8 MSBs of n2 coefficient for right DAC-programmable biquad A or Coefficient C35(15:8) of DAC miniDSP (DAC Buffer A)
71	0000 0000	8 LSBs of n2 coefficient for right DAC-programmable biquad A or Coefficient C35(7:0) of DAC miniDSP (DAC Buffer A)
72	0000 0000	8 MSBs of d1 coefficient for right DAC-programmable biquad A or Coefficient C36(15:8) of DAC miniDSP (DAC Buffer A)
73	0000 0000	8 LSBs of d1 coefficient for right DAC-programmable biquad A or Coefficient C36(7:0) of DAC miniDSP (DAC Buffer A)
74	0000 0000	8 MSBs of d2 coefficient for right DAC-programmable biquad A or Coefficient C37(15:8) of DAC miniDSP (DAC Buffer A)

Table 6-5. Page 8 Registers (continued)

REGISTER NUMBER	RESET VALUE	REGISTER NAME
75	0000 0000	8 LSBs of d2 coefficient for right DAC-programmable biquad A or Coefficient C37(7:0) of DAC miniDSP (DAC Buffer A)
76	0111 1111	8 MSBs of n0 coefficient for right DAC-programmable biquad B or Coefficient C38(15:8) of DAC miniDSP (DAC Buffer A)
77	1111 1111	8 LSBs of n0 coefficient for right DAC-programmable biquad B or Coefficient C38(7:0) of DAC miniDSP (DAC Buffer A)
78	0000 0000	8 MSBs of n1 coefficient for right DAC-programmable biquad B or Coefficient C39(15:8) of DAC miniDSP (DAC Buffer A)
79	0000 0000	8 LSBs of n1 coefficient for right DAC-programmable biquad B or Coefficient C39(7:0) of DAC miniDSP (DAC Buffer A)
80	0000 0000	8 MSBs of n2 coefficient for right DAC-programmable biquad B or Coefficient C40(15:8) of DAC miniDSP (DAC Buffer A)
81	0000 0000	8 LSBs of n2 coefficient for right DAC-programmable biquad B or Coefficient C40(7:0) of DAC miniDSP (DAC Buffer A)
82	0000 0000	8 MSBs of d1 coefficient for right DAC-programmable biquad B or Coefficient C41(15:8) of DAC miniDSP (DAC Buffer A)
83	0000 0000	8 LSBs of d1 coefficient for right DAC-programmable biquad B or Coefficient C41(7:0) of DAC miniDSP (DAC Buffer A)
84	0000 0000	8 MSBs of d2 coefficient for right DAC-programmable biquad B or Coefficient C42(15:8) of DAC miniDSP (DAC Buffer A)
85	0000 0000	8 LSBs of d2 coefficient for right DAC-programmable biquad B or Coefficient C42(7:0) of DAC miniDSP (DAC Buffer A)
86	0111 1111	8 MSBs of n0 coefficient for right DAC-programmable biquad C or Coefficient C43(15:8) of DAC miniDSP (DAC Buffer A)
87	1111 1111	8 LSBs of n0 coefficient for right DAC-programmable biquad C or Coefficient C43(7:0) of DAC miniDSP (DAC Buffer A)
88	0000 0000	8 MSBs of n1 coefficient for right DAC-programmable biquad C or Coefficient C44(15:8) of DAC miniDSP (DAC Buffer A)
89	0000 0000	8 LSBs of n1 coefficient for right DAC-programmable biquad C or Coefficient C44(7:0) of DAC miniDSP (DAC Buffer A)
90	0000 0000	8 MSBs of n2 coefficient for right DAC-programmable biquad C or Coefficient C45(15:8) of DAC miniDSP (DAC Buffer A)
91	0000 0000	8 LSBs of n2 coefficient for right DAC-programmable biquad C or Coefficient C45(7:0) of DAC miniDSP (DAC Buffer A)
92	0000 0000	8 MSBs of d1 coefficient for right DAC-programmable biquad C or Coefficient C46(15:8) of DAC miniDSP (DAC Buffer A)
93	0000 0000	8 LSBs of d1 coefficient for right DAC-programmable biquad C or Coefficient C46(7:0) of DAC miniDSP (DAC Buffer A)
94	0000 0000	8 MSBs of d2 coefficient for right DAC-programmable biquad C or Coefficient C47(15:8) of DAC miniDSP (DAC Buffer A)
95	0000 0000	8 LSBs of d2 coefficient for right DAC-programmable biquad C or Coefficient C47(7:0) of DAC miniDSP (DAC Buffer A)
96	0111 1111	8 MSBs of n0 coefficient for right DAC-programmable biquad D or Coefficient C48(15:8) of DAC miniDSP (DAC Buffer A)
97	1111 1111	8 LSBs of n0 coefficient for right DAC-programmable biquad D or Coefficient C48(7:0) of DAC miniDSP (DAC Buffer A)
98	0000 0000	8 MSBs of n1 coefficient for right DAC-programmable biquad D or Coefficient C49(15:8) of DAC miniDSP (DAC Buffer A)
99	0000 0000	8 LSBs of n1 coefficient for right DAC-programmable biquad D or Coefficient C49(7:0) of DAC miniDSP (DAC Buffer A)
100	0000 0000	8 MSBs of n2 coefficient for right DAC-programmable biquad D or Coefficient C50(15:8) of DAC miniDSP (DAC Buffer A)
101	0000 0000	8 LSBs of n2 coefficient for right DAC-programmable biquad D or Coefficient C50(7:0) of DAC miniDSP (DAC Buffer A)

Table 6-5. Page 8 Registers (continued)

REGISTER NUMBER	RESET VALUE	REGISTER NAME
102	0000 0000	8 MSBs of d1 coefficient for right DAC-programmable biquad D or Coefficient C51(15:8) of DAC miniDSP (DAC Buffer A)
103	0000 0000	8 LSBs of d1 coefficient for right DAC-programmable biquad D or Coefficient C51(7:0) of DAC miniDSP (DAC Buffer A)
104	0000 0000	8 MSBs of d2 coefficient for right DAC-programmable biquad D or Coefficient C52(15:8) of DAC miniDSP (DAC Buffer A)
105	0000 0000	8 LSBs of d2 coefficient for right DAC-programmable biquad D or Coefficient C52(7:0) of DAC miniDSP (DAC Buffer A)
106	0111 1111	8 MSBs of n0 coefficient for right DAC-programmable biquad E or Coefficient C53(15:8) of DAC miniDSP (DAC Buffer A)
107	1111 1111	8 LSBs of n0 coefficient for right DAC-programmable biquad E or Coefficient C53(7:0) of DAC miniDSP (DAC Buffer A)
108	0000 0000	8 MSBs of n1 coefficient for right DAC-programmable biquad E or Coefficient C54(15:8) of DAC miniDSP (DAC Buffer A)
109	0000 0000	8 LSBs of n1 coefficient for right DAC-programmable biquad E or Coefficient C54(7:0) of DAC miniDSP (DAC Buffer A)
110	0000 0000	8 MSBs of n2 coefficient for right DAC-programmable biquad E or Coefficient C55(15:8) of DAC miniDSP (DAC Buffer A)
111	0000 0000	8 LSBs of n2 coefficient for right DAC-programmable biquad E or Coefficient C55(7:0) of DAC miniDSP (DAC Buffer A)
112	0000 0000	8 MSBs of d1 coefficient for right DAC-programmable biquad E or Coefficient C56(15:8) of DAC miniDSP (DAC Buffer A)
113	0000 0000	8 LSBs of d1 coefficient for right DAC-programmable biquad E or Coefficient C56(7:0) of DAC miniDSP (DAC Buffer A)
114	0000 0000	8 MSBs of d2 coefficient for right DAC-programmable biquad E or Coefficient C57(15:8) of DAC miniDSP (DAC Buffer A)
115	0000 0000	8 LSBs of d2 coefficient for right DAC-programmable biquad E or Coefficient C57(7:0) of DAC miniDSP (DAC Buffer A)
116	0111 1111	8 MSBs of n0 coefficient for right DAC-programmable biquad F or Coefficient C58(15:8) of DAC miniDSP (DAC Buffer A)
117	1111 1111	8 LSBs of n0 coefficient for right DAC-programmable biquad F or Coefficient C58(7:0) of DAC miniDSP (DAC Buffer A)
118	0000 0000	8 MSBs of n1 coefficient for right DAC-programmable biquad F or Coefficient C59(15:8) of DAC miniDSP (DAC Buffer A)
119	0000 0000	8 LSBs of n1 coefficient for right DAC-programmable biquad F or Coefficient C59(7:0) of DAC miniDSP (DAC Buffer A)
120	0000 0000	8 MSBs of n2 coefficient for right DAC-programmable biquad F or Coefficient C60(15:8) of DAC miniDSP (DAC Buffer A)
121	0000 0000	8 LSBs of n2 coefficient for right DAC-programmable biquad F or Coefficient C60(7:0) of DAC miniDSP (DAC Buffer A)
122	0000 0000	8 MSBs of d1 coefficient for right DAC-programmable biquad F or Coefficient C61(15:8) of DAC miniDSP (DAC Buffer A)
123	0000 0000	8 LSBs of d1 coefficient for right DAC-programmable biquad F or Coefficient C61(7:0) of DAC miniDSP (DAC Buffer A)
124	0000 0000	8 MSBs of d2 coefficient for right DAC-programmable biquad F or Coefficient C62(15:8) of DAC miniDSP (DAC Buffer A)
125	0000 0000	8 LSBs of d2 coefficient for right DAC-programmable biquad F or Coefficient C62(7:0) of DAC miniDSP (DAC Buffer A)
126	0000 0000	Coefficient C63(15:8) of DAC miniDSP (DAC Buffer A)
127	0000 0000	Coefficient C63(7:0) of DAC miniDSP (DAC Buffer A)

6.8 Control Registers, Page 9: DAC Digital Filter Coefficients

Default values shown for this page only become valid 100 μ s following a hardware or software reset.

Page 9/Register 0: Page Control Register

BIT	READ/ WRITE	RESET VALUE	DESCRIPTION
D7–D0	R/W	0000 0000	0000 0000: Page 0 selected 0000 0001: Page 1 selected ... 1111 1110: Page 254 selected 1111 1111: Page 255 selected

The remaining page-9 registers are either reserved registers or are used for setting coefficients for the various filters in the TSC2117. Reserved registers should not be written to.

The filter coefficient registers are arranged in pairs, with two adjacent 8-bit registers containing the 16-bit coefficient for a single filter. The 16-bit integer contained in the MSB and LSB registers for a coefficient are interpreted as a 2s-complement integer, with possible values ranging from –32,768 to 32,767. When programming any coefficient value for a filter, the MSB register should always be written first, immediately followed by the LSB register. Even if only the MSB or LSB portion of the coefficient changes, both registers should be written in this sequence. [Table 6-6](#) is a list of the page-9 registers, excepting the previously described register 0.

Table 6-6. Page 9 Registers

REGISTER NUMBER	RESET VALUE	REGISTER NAME
1	XXXX XXXX	Reserved. Do not write to this register.
2	0111 1111	8 MSBs of n0 coefficient for left DAC-programmable first-order IIR or Coefficient C65(15:8) of DAC miniDSP (DAC Buffer A)
3	1111 1111	8 LSBs of n0 coefficient for left DAC-programmable first-order IIR or Coefficient C65(7:0) of DAC miniDSP (DAC Buffer A)
4	0000 0000	8 MSBs of n1 coefficient for left DAC-programmable first-order IIR or Coefficient C66(15:8) of DAC miniDSP (DAC Buffer A)
5	0000 0000	8 LSBs of n1 coefficient for left DAC-programmable first-order IIR or Coefficient C66(7:0) of DAC miniDSP (DAC Buffer A)
6	0000 0000	8 MSBs of d1 coefficient for left DAC-programmable first-order IIR or Coefficient C67(15:8) of DAC miniDSP (DAC Buffer A)
7	0000 0000	8 LSBs of d1 coefficient for left DAC-programmable first-order IIR or Coefficient C67(7:0) of DAC miniDSP (DAC Buffer A)
8	0111 1111	8 MSBs of n0 coefficient for right DAC-programmable first-order IIR or Coefficient C68(15:8) of DAC miniDSP (DAC Buffer A)
9	1111 1111	8 LSBs of n0 coefficient for right DAC-programmable first-order IIR or Coefficient C68(7:0) of DAC miniDSP (DAC Buffer A)
10	0000 0000	8 MSBs of n1 coefficient for right DAC-programmable first-order IIR or Coefficient C69(15:8) of DAC miniDSP (DAC Buffer A)
11	0000 0000	8 LSBs of n1 coefficient for right DAC-programmable first-order IIR or Coefficient C69(7:0) of DAC miniDSP (DAC Buffer A)
12	0000 0000	8 MSBs of d1 coefficient for right DAC-programmable first-order IIR or Coefficient C70(15:8) of DAC miniDSP (DAC Buffer A)
13	0000 0000	8 LSBs of d1 coefficient for right DAC-programmable first-order IIR or Coefficient C70(7:0) of DAC miniDSP (DAC Buffer A)
14	0111 1111	8 MSBs of n0 coefficient for DRC first-order high-pass filter or Coefficient C71(15:8) of DAC miniDSP (DAC Buffer A)
15	1111 0111	8 LSBs of n0 coefficient for DRC first-order high-pass filter or Coefficient C71(7:0) of DAC miniDSP (DAC Buffer A)
16	1000 0000	8 MSBs of n1 coefficient for DRC first-order high-pass filter or Coefficient C72(15:8) of DAC miniDSP (DAC Buffer A)

Table 6-6. Page 9 Registers (continued)

REGISTER NUMBER	RESET VALUE	REGISTER NAME
17	0000 1001	8 LSBs of n1 coefficient for DRC first-order high-pass filter or Coefficient C72(7:0) of DAC miniDSP (DAC Buffer A)
18	0111 1111	8 MSBs of d1 coefficient for DRC first-order high-pass filter or Coefficient C73(15:8) of DAC miniDSP (DAC Buffer A)
19	1110 1111	8 LSBs of d1 coefficient for DRC first-order high-pass filter or Coefficient C73(7:0) of DAC miniDSP (DAC Buffer A)
20	0000 0000	8 MSBs of n0 coefficient for DRC first-order low-pass filter or Coefficient C74(15:8) of DAC miniDSP (DAC Buffer A)
21	0001 0001	8 LSBs of n0 coefficient for DRC first-order low-pass filter or Coefficient C74(7:0) of DAC miniDSP (DAC Buffer A)
22	0000 0000	8 MSBs of n1 coefficient for DRC first-order low-pass filter or Coefficient C75(15:8) of DAC miniDSP (DAC Buffer A)
23	0001 0001	8 LSBs of n1 coefficient for DRC first-order low-pass filter or Coefficient C75(7:0) of DAC miniDSP (DAC Buffer A)
24	0111 1111	8 MSBs of d1 coefficient for DRC first-order low-pass filter or Coefficient C76(15:8) of DAC miniDSP (DAC Buffer A)
25	1101 1110	8 LSBs of d1 coefficient for DRC first-order low-pass filter or Coefficient C76(7:0) of DAC miniDSP (DAC Buffer A)
26	0000 0000	Coefficient C77(15:8) of DAC miniDSP (DAC Buffer A)
27	0000 0000	Coefficient C77(7:0) of DAC miniDSP (DAC Buffer A)
28	0000 0000	Coefficient C78(15:8) of DAC miniDSP (DAC Buffer A)
29	0000 0000	Coefficient C78(7:0) of DAC miniDSP (DAC Buffer A)
30	0000 0000	Coefficient C79(15:8) of DAC miniDSP (DAC Buffer A)
31	0000 0000	Coefficient C79(7:0) of DAC miniDSP (DAC Buffer A)
32	0000 0000	Coefficient C80(15:8) of DAC miniDSP (DAC Buffer A)
33	0000 0000	Coefficient C80(7:0) of DAC miniDSP (DAC Buffer A)
34	0000 0000	Coefficient C81(15:8) of DAC miniDSP (DAC Buffer A)
35	0000 0000	Coefficient C81(7:0) of DAC miniDSP (DAC Buffer A)
36	0000 0000	Coefficient C82(15:8) of DAC miniDSP (DAC Buffer A)
37	0000 0000	Coefficient C82(7:0) of DAC miniDSP (DAC Buffer A)
38	0000 0000	Coefficient C83(15:8) of DAC miniDSP (DAC Buffer A)
39	0000 0000	Coefficient C83(7:0) of DAC miniDSP (DAC Buffer A)
40	0000 0000	Coefficient C84(15:8) of DAC miniDSP (DAC Buffer A)
41	0000 0000	Coefficient C84(7:0) of DAC miniDSP (DAC Buffer A)
42	0000 0000	Coefficient C85(15:8) of DAC miniDSP (DAC Buffer A)
43	0000 0000	Coefficient C85(7:0) of DAC miniDSP (DAC Buffer A)
44	0000 0000	Coefficient C86(15:8) of DAC miniDSP (DAC Buffer A)
45	0000 0000	Coefficient C86(7:0) of DAC miniDSP (DAC Buffer A)
46	0000 0000	Coefficient C87(15:8) of DAC miniDSP (DAC Buffer A)
47	0000 0000	Coefficient C87(7:0) of DAC miniDSP (DAC Buffer A)
48	0000 0000	Coefficient C88(15:8) of DAC miniDSP (DAC Buffer A)
49	0000 0000	Coefficient C88(7:0) of DAC miniDSP (DAC Buffer A)
50	0000 0000	Coefficient C89(15:8) of DAC miniDSP (DAC Buffer A)
51	0000 0000	Coefficient C89(7:0) of DAC miniDSP (DAC Buffer A)
52	0000 0000	Coefficient C90(15:8) of DAC miniDSP (DAC Buffer A)
53	0000 0000	Coefficient C90(7:0) of DAC miniDSP (DAC Buffer A)
54	0000 0000	Coefficient C91(15:8) of DAC miniDSP (DAC Buffer A)
55	0000 0000	Coefficient C91(7:0) of DAC miniDSP (DAC Buffer A)
56	0000 0000	Coefficient C92(15:8) of DAC miniDSP (DAC Buffer A)

Table 6-6. Page 9 Registers (continued)

REGISTER NUMBER	RESET VALUE	REGISTER NAME
57	0000 0000	Coefficient C92(7:0) of DAC miniDSP (DAC Buffer A)
58	0000 0000	Coefficient C93(15:8) of DAC miniDSP (DAC Buffer A)
59	0000 0000	Coefficient C93(7:0) of DAC miniDSP (DAC Buffer A)
60	0000 0000	Coefficient C94(15:8) of DAC miniDSP (DAC Buffer A)
61	0000 0000	Coefficient C94(7:0) of DAC miniDSP (DAC Buffer A)
62	0000 0000	Coefficient C95(15:8) of DAC miniDSP (DAC Buffer A)
63	0000 0000	Coefficient C95(7:0) of DAC miniDSP (DAC Buffer A)
64	0000 0000	Coefficient C96(15:8) of DAC miniDSP (DAC Buffer A)
65	0000 0000	Coefficient C96(7:0) of DAC miniDSP (DAC Buffer A)
66	0000 0000	Coefficient C97(15:8) of DAC miniDSP (DAC Buffer A)
67	0000 0000	Coefficient C97(7:0) of DAC miniDSP (DAC Buffer A)
68	0000 0000	Coefficient C98(15:8) of DAC miniDSP (DAC Buffer A)
69	0000 0000	Coefficient C98(7:0) of DAC miniDSP (DAC Buffer A)
70	0000 0000	Coefficient C99(15:8) of DAC miniDSP (DAC Buffer A)
71	0000 0000	Coefficient C99(7:0) of DAC miniDSP (DAC Buffer A)
72	0000 0000	Coefficient C100(15:8) of DAC miniDSP (DAC Buffer A)
73	0000 0000	Coefficient C100(7:0) of DAC miniDSP (DAC Buffer A)
74	0000 0000	Coefficient C101(15:8) of DAC miniDSP (DAC Buffer A)
75	0000 0000	Coefficient C101(7:0) of DAC miniDSP (DAC Buffer A)
76	0000 0000	Coefficient C102(15:8) of DAC miniDSP (DAC Buffer A)
77	0000 0000	Coefficient C102(7:0) of DAC miniDSP (DAC Buffer A)
78	0000 0000	Coefficient C103(15:8) of DAC miniDSP (DAC Buffer A)
79	0000 0000	Coefficient C103(7:0) of DAC miniDSP (DAC Buffer A)
80	0000 0000	Coefficient C104(15:8) of DAC miniDSP (DAC Buffer A)
81	0000 0000	Coefficient C104(7:0) of DAC miniDSP (DAC Buffer A)
82	0000 0000	Coefficient C105(15:8) of DAC miniDSP (DAC Buffer A)
83	0000 0000	Coefficient C105(7:0) of DAC miniDSP (DAC Buffer A)
84	0000 0000	Coefficient C106(15:8) of DAC miniDSP (DAC Buffer A)
85	0000 0000	Coefficient C106(7:0) of DAC miniDSP (DAC Buffer A)
86	0000 0000	Coefficient C107(15:8) of DAC miniDSP (DAC Buffer A)
87	0000 0000	Coefficient C107(15:8) of DAC miniDSP (DAC Buffer A)
88	0000 0000	Coefficient C108(7:0) of DAC miniDSP (DAC Buffer A)
89	0000 0000	Coefficient C108(7:0) of DAC miniDSP (DAC Buffer A)
90	0000 0000	Coefficient C109(15:8) of DAC miniDSP (DAC Buffer A)
91	0000 0000	Coefficient C109(7:0) of DAC miniDSP (DAC Buffer A)
92	0000 0000	Coefficient C110(15:8) of DAC miniDSP (DAC Buffer A)
93	0000 0000	Coefficient C110(7:0) of DAC miniDSP (DAC Buffer A)
94	0000 0000	Coefficient C111(15:8) of DAC miniDSP (DAC Buffer A)
95	0000 0000	Coefficient C111(7:0) of DAC miniDSP (DAC Buffer A)
96	0000 0000	Coefficient C112(15:8) of DAC miniDSP (DAC Buffer A)
97	0000 0000	Coefficient C112(7:0) of DAC miniDSP (DAC Buffer A)
98	0000 0000	Coefficient C113(15:8) of DAC miniDSP (DAC Buffer A)
99	0000 0000	Coefficient C113(7:0) of DAC miniDSP (DAC Buffer A)
100	0000 0000	Coefficient C114(15:8) of DAC miniDSP (DAC Buffer A)
101	0000 0000	Coefficient C114(7:0) of DAC miniDSP (DAC Buffer A)
102	0000 0000	Coefficient C115(15:8) of DAC miniDSP (DAC Buffer A)
103	0000 0000	Coefficient C115(7:0) of DAC miniDSP (DAC Buffer A)

Table 6-6. Page 9 Registers (continued)

REGISTER NUMBER	RESET VALUE	REGISTER NAME
104	0000 0000	Coefficient C116(15:8) of DAC miniDSP (DAC Buffer A)
105	0000 0000	Coefficient C116(7:0) of DAC miniDSP (DAC Buffer A)
106	0000 0000	Coefficient C117(15:8) of DAC miniDSP (DAC Buffer A)
107	0000 0000	Coefficient C117(7:0) of DAC miniDSP (DAC Buffer A)
108	0000 0000	Coefficient C118(15:8) of DAC miniDSP (DAC Buffer A)
109	0000 0000	Coefficient C118(7:0) of DAC miniDSP (DAC Buffer A)
110	0000 0000	Coefficient C119(15:8) of DAC miniDSP (DAC Buffer A)
111	0000 0000	Coefficient C119(7:0) of DAC miniDSP (DAC Buffer A)
112	0000 0000	Coefficient C120(15:8) of DAC miniDSP (DAC Buffer A)
113	0000 0000	Coefficient C120(7:0) of DAC miniDSP (DAC Buffer A)
114	0000 0000	Coefficient C121(15:8) of DAC miniDSP (DAC Buffer A)
115	0000 0000	Coefficient C121(7:0) of DAC miniDSP (DAC Buffer A)
116	0000 0000	Coefficient C122(15:8) of DAC miniDSP (DAC Buffer A)
117	0000 0000	Coefficient C122(7:0) of DAC miniDSP (DAC Buffer A)
118	0000 0000	Coefficient C123(15:8) of DAC miniDSP (DAC Buffer A)
119	0000 0000	Coefficient C123(7:0) of DAC miniDSP (DAC Buffer A)
120	0000 0000	Coefficient C124(15:8) of DAC miniDSP (DAC Buffer A)
121	0000 0000	Coefficient C124(7:0) of DAC miniDSP (DAC Buffer A)
122	0000 0000	Coefficient C125(15:8) of DAC miniDSP (DAC Buffer A)
123	0000 0000	Coefficient C125(7:0) of DAC miniDSP (DAC Buffer A)
124	0000 0000	Coefficient C126(15:8) of DAC miniDSP (DAC Buffer A)
125	0000 0000	Coefficient C126(7:0) of DAC miniDSP (DAC Buffer A)
126	0000 0000	Coefficient C127(15:8) of DAC miniDSP (DAC Buffer A)
127	0000 0000	Coefficient C127(7:0) of DAC miniDSP (DAC Buffer A)

6.9 Control Registers, Page 10: DAC Programmable Coefficients RAM Buffer A (129:191)**Table 6-7. Page 10 Registers**

REGISTER NUMBER	RESET VALUE	REGISTER NAME
1	XXXX XXXX	Reserved. Do not write to this register.
2	0000 0000	Coefficient C129(15:8) of DAC buffer A
3	0000 0000	Coefficient C129(7:0) of DAC buffer A
4	0000 0000	Coefficient C130(15:8) of DAC buffer A
5	0000 0000	Coefficient C130(7:0) of DAC buffer A
6	0000 0000	Coefficient C131(15:8) of DAC buffer A
7	0000 0000	Coefficient C131(7:0) of DAC buffer A
8	0000 0000	Coefficient C132(15:8) of DAC buffer A
9	0000 0000	Coefficient C132(7:0) of DAC buffer A
10	0000 0000	Coefficient C133(15:8) of DAC buffer A
11	0000 0000	Coefficient C133(7:0) of DAC buffer A
12	0000 0000	Coefficient C134(15:8) of DAC buffer A
13	0000 0000	Coefficient C134(7:0) of DAC buffer A
14	0000 0000	Coefficient C135(15:8) of DAC buffer A
15	0000 0000	Coefficient C135(7:0) of DAC buffer A

Table 6-7. Page 10 Registers (continued)

REGISTER NUMBER	RESET VALUE	REGISTER NAME
16	0000 0000	Coefficient C136(15:8) of DAC buffer A
17	0000 0000	Coefficient C136(7:0) of DAC buffer A
18	0000 0000	Coefficient C137(15:8) of DAC buffer A
19	0000 0000	Coefficient C137(7:0) of DAC buffer A
20	0000 0000	Coefficient C138(15:8) of DAC buffer A
21	0000 0000	Coefficient C138(7:0) of DAC buffer A
22	0000 0000	Coefficient C139(15:8) of DAC buffer A
23	0000 0000	Coefficient C139(7:0) of DAC buffer A
24	0000 0000	Coefficient C140(15:8) of DAC buffer A
25	0000 0000	Coefficient C140(7:0) of DAC buffer A
26	0000 0000	Coefficient C141(15:8) of DAC buffer A
27	0000 0000	Coefficient C141(7:0) of DAC buffer A
28	0000 0000	Coefficient C142(15:8) of DAC buffer A
29	0000 0000	Coefficient C142(7:0) of DAC buffer A
30	0000 0000	Coefficient C143(15:8) of DAC buffer A
31	0000 0000	Coefficient C143(7:0) of DAC buffer A
32	0000 0000	Coefficient C144(15:8) of DAC buffer A
33	0000 0000	Coefficient C144(7:0) of DAC buffer A
34	0000 0000	Coefficient C145(15:8) of DAC buffer A
35	0000 0000	Coefficient C145(7:0) of DAC buffer A
36	0000 0000	Coefficient C146(15:8) of DAC buffer A
37	0000 0000	Coefficient C146(7:0) of DAC buffer A
38	0000 0000	Coefficient C147(15:8) of DAC buffer A
39	0000 0000	Coefficient C147(7:0) of DAC buffer A
40	0000 0000	Coefficient C148(15:8) of DAC buffer A
41	0000 0000	Coefficient C148(7:0) of DAC buffer A
42	0000 0000	Coefficient C149(15:8) of DAC buffer A
43	0000 0000	Coefficient C149(7:0) of DAC buffer A
44	0000 0000	Coefficient C150(15:8) of DAC buffer A
45	0000 0000	Coefficient C150(7:0) of DAC buffer A
46	0000 0000	Coefficient C151(15:8) of DAC buffer A
47	0000 0000	Coefficient C151(7:0) of DAC buffer A
48	0000 0000	Coefficient C152(15:8) of DAC buffer A
49	0000 0000	Coefficient C152(7:0) of DAC buffer A
50	0000 0000	Coefficient C153(15:8) of DAC buffer A
51	0000 0000	Coefficient C153(7:0) of DAC buffer A
52	0000 0000	Coefficient C154(15:8) of DAC buffer A
53	0000 0000	Coefficient C154(7:0) of DAC buffer A
54	0000 0000	Coefficient C155(15:8) of DAC buffer A
55	0000 0000	Coefficient C155(7:0) of DAC buffer A
56	0000 0000	Coefficient C156(15:8) of DAC buffer A
57	0000 0000	Coefficient C156(7:0) of DAC buffer A
58	0000 0000	Coefficient C157(15:8) of DAC buffer A
59	0000 0000	Coefficient C157(7:0) of DAC buffer A
60	0000 0000	Coefficient C158(15:8) of DAC buffer A
61	0000 0000	Coefficient C158(7:0) of DAC buffer A
62	0000 0000	Coefficient C159(15:8) of DAC buffer A

Table 6-7. Page 10 Registers (continued)

REGISTER NUMBER	RESET VALUE	REGISTER NAME
63	0000 0000	Coefficient C159(7:0) of DAC buffer A
64	0000 0000	Coefficient C160(15:8) of DAC buffer A
65	0000 0000	Coefficient C160(7:0) of DAC buffer A
66	0000 0000	Coefficient C161(15:8) of DAC buffer A
67	0000 0000	Coefficient C161(7:0) of DAC buffer A
68	0000 0000	Coefficient C162(15:8) of DAC buffer A
69	0000 0000	Coefficient C162(7:0) of DAC buffer A
70	0000 0000	Coefficient C163(15:8) of DAC buffer A
71	0000 0000	Coefficient C163(7:0) of DAC buffer A
72	0000 0000	Coefficient C164(15:8) of DAC buffer A
73	0000 0000	Coefficient C164(7:0) of DAC buffer A
74	0000 0000	Coefficient C165(15:8) of DAC buffer A
75	0000 0000	Coefficient C165(7:0) of DAC buffer A
76	0000 0000	Coefficient C166(15:8) of DAC buffer A
77	0000 0000	Coefficient C166(7:0) of DAC buffer A
78	0000 0000	Coefficient C167(15:8) of DAC buffer A
79	0000 0000	Coefficient C167(7:0) of DAC buffer A
80	0000 0000	Coefficient C168(15:8) of DAC buffer A
81	0000 0000	Coefficient C168(7:0) of DAC buffer A
82	0000 0000	Coefficient C169(15:8) of DAC buffer A
83	0000 0000	Coefficient C169(7:0) of DAC buffer A
84	0000 0000	Coefficient C170(15:8) of DAC buffer A
85	0000 0000	Coefficient C170(7:0) of DAC buffer A
86	0000 0000	Coefficient C171(15:8) of DAC buffer A
87	0000 0000	Coefficient C171(7:0) of DAC buffer A
88	0000 0000	Coefficient C172(15:8) of DAC buffer A
89	0000 0000	Coefficient C172(7:0) of DAC buffer A
90	0000 0000	Coefficient C173(15:8) of DAC buffer A
91	0000 0000	Coefficient C173(7:0) of DAC buffer A
92	0000 0000	Coefficient C174(15:8) of DAC buffer A
93	0000 0000	Coefficient C174(7:0) of DAC buffer A
94	0000 0000	Coefficient C175(15:8) of DAC buffer A
95	0000 0000	Coefficient C175(7:0) of DAC buffer A
96	0000 0000	Coefficient C176(15:8) of DAC buffer A
97	0000 0000	Coefficient C176(7:0) of DAC buffer A
98	0000 0000	Coefficient C177(15:8) of DAC buffer A
99	0000 0000	Coefficient C177(7:0) of DAC buffer A
100	0000 0000	Coefficient C178(15:8) of DAC buffer A
101	0000 0000	Coefficient C178(7:0) of DAC buffer A
102	0000 0000	Coefficient C179(15:8) of DAC buffer A
103	0000 0000	Coefficient C179(7:0) of DAC buffer A
104	0000 0000	Coefficient C180(15:8) of DAC buffer A
105	0000 0000	Coefficient C180(7:0) of DAC buffer A
106	0000 0000	Coefficient C181(15:8) of DAC buffer A
107	0000 0000	Coefficient C181(7:0) of DAC buffer A
108	0000 0000	Coefficient C182(15:8) of DAC buffer A
109	0000 0000	Coefficient C182(7:0) of DAC buffer A

Table 6-7. Page 10 Registers (continued)

REGISTER NUMBER	RESET VALUE	REGISTER NAME
110	0000 0000	Coefficient C183(15:8) of DAC buffer A
111	0000 0000	Coefficient C183(7:0) of DAC buffer A
112	0000 0000	Coefficient C184(15:8) of DAC buffer A
113	0000 0000	Coefficient C184(7:0) of DAC buffer A
114	0000 0000	Coefficient C185(15:8) of DAC buffer A
115	0000 0000	Coefficient C185(7:0) of DAC buffer A
116	0000 0000	Coefficient C186(15:8) of DAC buffer A
117	0000 0000	Coefficient C186(7:0) of DAC buffer A
118	0000 0000	Coefficient C187(15:8) of DAC buffer A
119	0000 0000	Coefficient C187(7:0) of DAC buffer A
120	0000 0000	Coefficient C188(15:8) of DAC buffer A
121	0000 0000	Coefficient C188(7:0) of DAC buffer A
122	0000 0000	Coefficient C189(15:8) of DAC buffer A
123	0000 0000	Coefficient C189(7:0) of DAC buffer A
124	0000 0000	Coefficient C190(15:8) of DAC buffer A
125	0000 0000	Coefficient C190(7:0) of DAC buffer A
126	0000 0000	Coefficient C191(15:8) of DAC buffer A
127	0000 0000	Coefficient C191(7:0) of DAC buffer A

6.10 Control Registers, Page 11: DAC Programmable Coefficients RAM Buffer A (193:255)
Table 6-8. Page 11 Registers

REGISTER NUMBER	RESET VALUE	REGISTER NAME
1	XXXX XXXX	Reserved. Do not write to this register.
2	0000 0000	Coefficient C193(15:8) of DAC buffer A
3	0000 0000	Coefficient C193(7:0) of DAC buffer A
4	0000 0000	Coefficient C194(15:8) of DAC buffer A
5	0000 0000	Coefficient C194(7:0) of DAC buffer A
6	0000 0000	Coefficient C195(15:8) of DAC buffer A
7	0000 0000	Coefficient C195(7:0) of DAC buffer A
8	0000 0000	Coefficient C196(15:8) of DAC buffer A
9	0000 0000	Coefficient C196(7:0) of DAC buffer A
10	0000 0000	Coefficient C197(15:8) of DAC buffer A
11	0000 0000	Coefficient C197(7:0) of DAC buffer A
12	0000 0000	Coefficient C198(15:8) of DAC buffer A
13	0000 0000	Coefficient C198(7:0) of DAC buffer A
14	0000 0000	Coefficient C199(15:8) of DAC buffer A
15	0000 0000	Coefficient C199(7:0) of DAC buffer A
16	0000 0000	Coefficient C200(15:8) of DAC buffer A
17	0000 0000	Coefficient C200(7:0) of DAC buffer A
18	0000 0000	Coefficient C201(15:8) of DAC buffer A
19	0000 0000	Coefficient C201(7:0) of DAC buffer A
20	0000 0000	Coefficient C202(15:8) of DAC buffer A
21	0000 0000	Coefficient C202(7:0) of DAC buffer A

Table 6-8. Page 11 Registers (continued)

REGISTER NUMBER	RESET VALUE	REGISTER NAME
22	0000 0000	Coefficient C203(15:8) of DAC buffer A
23	0000 0000	Coefficient C203(7:0) of DAC buffer A
24	0000 0000	Coefficient C204(15:8) of DAC buffer A
25	0000 0000	Coefficient C204(7:0) of DAC buffer A
26	0000 0000	Coefficient C205(15:8) of DAC buffer A
27	0000 0000	Coefficient C205(7:0) of DAC buffer A
28	0000 0000	Coefficient C206(15:8) of DAC buffer A
29	0000 0000	Coefficient C206(7:0) of DAC buffer A
30	0000 0000	Coefficient C207(15:8) of DAC buffer A
31	0000 0000	Coefficient C207(7:0) of DAC buffer A
32	0000 0000	Coefficient C208(15:8) of DAC buffer A
33	0000 0000	Coefficient C208(7:0) of DAC buffer A
34	0000 0000	Coefficient C209(15:8) of DAC buffer A
35	0000 0000	Coefficient C209(7:0) of DAC buffer A
36	0000 0000	Coefficient C210(15:8) of DAC buffer A
37	0000 0000	Coefficient C210(7:0) of DAC buffer A
38	0000 0000	Coefficient C211(15:8) of DAC buffer A
39	0000 0000	Coefficient C211(7:0) of DAC buffer A
40	0000 0000	Coefficient C212(15:8) of DAC buffer A
41	0000 0000	Coefficient C212(7:0) of DAC buffer A
42	0000 0000	Coefficient C213(15:8) of DAC buffer A
43	0000 0000	Coefficient C213(7:0) of DAC buffer A
44	0000 0000	Coefficient C214(15:8) of DAC buffer A
45	0000 0000	Coefficient C214(7:0) of DAC buffer A
46	0000 0000	Coefficient C215(15:8) of DAC buffer A
47	0000 0000	Coefficient C215(7:0) of DAC buffer A
48	0000 0000	Coefficient C216(15:8) of DAC buffer A
49	0000 0000	Coefficient C216(7:0) of DAC buffer A
50	0000 0000	Coefficient C217(15:8) of DAC buffer A
51	0000 0000	Coefficient C217(7:0) of DAC buffer A
52	0000 0000	Coefficient C218(15:8) of DAC buffer A
53	0000 0000	Coefficient C218(7:0) of DAC buffer A
54	0000 0000	Coefficient C219(15:8) of DAC buffer A
55	0000 0000	Coefficient C219(7:0) of DAC buffer A
56	0000 0000	Coefficient C220(15:8) of DAC buffer A
57	0000 0000	Coefficient C220(7:0) of DAC buffer A
58	0000 0000	Coefficient C221(15:8) of DAC buffer A
59	0000 0000	Coefficient C221(7:0) of DAC buffer A
60	0000 0000	Coefficient C222(15:8) of DAC buffer A
61	0000 0000	Coefficient C222(7:0) of DAC buffer A
62	0000 0000	Coefficient C223(15:8) of DAC buffer A
63	0000 0000	Coefficient C223(7:0) of DAC buffer A
64	0000 0000	Coefficient C224(15:8) of DAC buffer A
65	0000 0000	Coefficient C224(7:0) of DAC buffer A
66	0000 0000	Coefficient C225(15:8) of DAC buffer A
67	0000 0000	Coefficient C225(7:0) of DAC buffer A
68	0000 0000	Coefficient C226(15:8) of DAC buffer A

Table 6-8. Page 11 Registers (continued)

REGISTER NUMBER	RESET VALUE	REGISTER NAME
69	0000 0000	Coefficient C226(7:0) of DAC buffer A
70	0000 0000	Coefficient C227(15:8) of DAC buffer A
71	0000 0000	Coefficient C227(7:0) of DAC buffer A
72	0000 0000	Coefficient C228(15:8) of DAC buffer A
73	0000 0000	Coefficient C228(7:0) of DAC buffer A
74	0000 0000	Coefficient C229(15:8) of DAC buffer A
75	0000 0000	Coefficient C229(7:0) of DAC buffer A
76	0000 0000	Coefficient C230(15:8) of DAC buffer A
77	0000 0000	Coefficient C230(7:0) of DAC buffer A
78	0000 0000	Coefficient C231(15:8) of DAC buffer A
79	0000 0000	Coefficient C231(7:0) of DAC buffer A
80	0000 0000	Coefficient C232(15:8) of DAC buffer A
81	0000 0000	Coefficient C232(7:0) of DAC buffer A
82	0000 0000	Coefficient C233(15:8) of DAC buffer A
83	0000 0000	Coefficient C233(7:0) of DAC buffer A
84	0000 0000	Coefficient C234(15:8) of DAC buffer A
85	0000 0000	Coefficient C234(7:0) of DAC buffer A
86	0000 0000	Coefficient C235(15:8) of DAC buffer A
87	0000 0000	Coefficient C235(7:0) of DAC buffer A
88	0000 0000	Coefficient C236(15:8) of DAC buffer A
89	0000 0000	Coefficient C236(7:0) of DAC buffer A
90	0000 0000	Coefficient C237(15:8) of DAC buffer A
91	0000 0000	Coefficient C237(7:0) of DAC buffer A
92	0000 0000	Coefficient C238(15:8) of DAC buffer A
93	0000 0000	Coefficient C238(7:0) of DAC buffer A
94	0000 0000	Coefficient C239(15:8) of DAC buffer A
95	0000 0000	Coefficient C239(7:0) of DAC buffer A
96	0000 0000	Coefficient C240(15:8) of DAC buffer A
97	0000 0000	Coefficient C240(7:0) of DAC buffer A
98	0000 0000	Coefficient C241(15:8) of DAC buffer A
99	0000 0000	Coefficient C241(7:0) of DAC buffer A
100	0000 0000	Coefficient C242(15:8) of DAC buffer A
101	0000 0000	Coefficient C242(7:0) of DAC buffer A
102	0000 0000	Coefficient C243(15:8) of DAC buffer A
103	0000 0000	Coefficient C243(7:0) of DAC buffer A
104	0000 0000	Coefficient C244(15:8) of DAC buffer A
105	0000 0000	Coefficient C244(7:0) of DAC buffer A
106	0000 0000	Coefficient C245(15:8) of DAC buffer A
107	0000 0000	Coefficient C245(7:0) of DAC buffer A
108	0000 0000	Coefficient C246(15:8) of DAC buffer A
109	0000 0000	Coefficient C246(7:0) of DAC buffer A
110	0000 0000	Coefficient C247(15:8) of DAC buffer A
111	0000 0000	Coefficient C247(7:0) of DAC buffer A
112	0000 0000	Coefficient C248(15:8) of DAC buffer A
113	0000 0000	Coefficient C248(7:0) of DAC buffer A
114	0000 0000	Coefficient C249(15:8) of DAC buffer A
115	0000 0000	Coefficient C249(7:0) of DAC buffer A

Table 6-8. Page 11 Registers (continued)

REGISTER NUMBER	RESET VALUE	REGISTER NAME
116	0000 0000	Coefficient C250(15:8) of DAC buffer A
117	0000 0000	Coefficient C250(7:0) of DAC buffer A
118	0000 0000	Coefficient C251(15:8) of DAC buffer A
119	0000 0000	Coefficient C251(7:0) of DAC buffer A
120	0000 0000	Coefficient C252(15:8) of DAC buffer A
121	0000 0000	Coefficient C252(7:0) of DAC buffer A
122	0000 0000	Coefficient C253(15:8) of DAC buffer A
123	0000 0000	Coefficient C253(7:0) of DAC buffer A
124	0000 0000	Coefficient C254(15:8) of DAC buffer A
125	0000 0000	Coefficient C254(7:0) of DAC buffer A
126	0000 0000	Coefficient C255(15:8) of DAC buffer A
127	0000 0000	Coefficient C255(7:0) of DAC buffer A

6.11 Control Registers, Page 12: DAC Programmable Coefficients RAM Buffer B (1:63)**Table 6-9. Page 12 Registers**

REGISTER NUMBER	RESET VALUE	REGISTER NAME
1	0000 0000	Reserved. Do not write to this register.
2	0111 1111	Coefficient C1(15:8) of DAC buffer B
3	1111 1111	Coefficient C1(7:0) of DAC buffer B
4	0000 0000	Coefficient C2(15:8) of DAC buffer B
5	0000 0000	Coefficient C2(7:0) of DAC buffer B
6	0000 0000	Coefficient C3(15:8) of DAC buffer B
7	0000 0000	Coefficient C3(7:0) of DAC buffer B
8	0000 0000	Coefficient C4(15:8) of DAC buffer B
9	0000 0000	Coefficient C4(7:0) of DAC buffer B
10	0000 0000	Coefficient C5(15:8) of DAC buffer B
11	0000 0000	Coefficient C5(7:0) of DAC buffer B
12	0111 1111	Coefficient C6(15:8) of DAC buffer B
13	1111 1111	Coefficient C6(7:0) of DAC buffer B
14	0000 0000	Coefficient C7(15:8) of DAC buffer B
15	0000 0000	Coefficient C7(7:0) of DAC buffer B
16	0000 0000	Coefficient C8(15:8) of DAC buffer B
17	0000 0000	Coefficient C8(7:0) of DAC buffer B
18	0000 0000	Coefficient C9(15:8) of DAC buffer B
19	0000 0000	Coefficient C9(7:0) of DAC buffer B
20	0000 0000	Coefficient C10(15:8) of DAC buffer B
21	0000 0000	Coefficient C10(7:0) of DAC buffer B
22	0111 1111	Coefficient C11(15:8) of DAC buffer B
23	1111 1111	Coefficient C11(7:0) of DAC buffer B
24	0000 0000	Coefficient C12(15:8) of DAC buffer B
25	0000 0000	Coefficient C12(7:0) of DAC buffer B
26	0000 0000	Coefficient C13(15:8) of DAC buffer B
27	0000 0000	Coefficient C13(7:0) of DAC buffer B

Table 6-9. Page 12 Registers (continued)

REGISTER NUMBER	RESET VALUE	REGISTER NAME
28	0000 0000	Coefficient C14(15:8) of DAC buffer B
29	0000 0000	Coefficient C14(7:0) of DAC buffer B
30	0000 0000	Coefficient C15(15:8) of DAC buffer B
31	0000 0000	Coefficient C15(7:0) of DAC buffer B
32	0111 1111	Coefficient C16(15:8) of DAC buffer B
33	1111 1111	Coefficient C16(7:0) of DAC buffer B
34	0000 0000	Coefficient C17(15:8) of DAC buffer B
35	0000 0000	Coefficient C17(7:0) of DAC buffer B
36	0000 0000	Coefficient C18(15:8) of DAC buffer B
37	0000 0000	Coefficient C18(7:0) of DAC buffer B
38	0000 0000	Coefficient C19(15:8) of DAC buffer B
39	0000 0000	Coefficient C19(7:0) of DAC buffer B
40	0000 0000	Coefficient C20(15:8) of DAC buffer B
41	0000 0000	Coefficient C20(7:0) of DAC buffer B
42	0111 1111	Coefficient C21(15:8) of DAC buffer B
43	1111 1111	Coefficient C21(7:0) of DAC buffer B
44	0000 0000	Coefficient C22(15:8) of DAC buffer B
45	0000 0000	Coefficient C22(7:0) of DAC buffer B
46	0000 0000	Coefficient C23(15:8) of DAC buffer B
47	0000 0000	Coefficient C23(7:0) of DAC buffer B
48	0000 0000	Coefficient C24(15:8) of DAC buffer B
49	0000 0000	Coefficient C24(7:0) of DAC buffer B
50	0000 0000	Coefficient C25(15:8) of DAC buffer B
51	0000 0000	Coefficient C25(7:0) of DAC buffer B
52	0111 1111	Coefficient C26(15:8) of DAC buffer B
53	1111 1111	Coefficient C26(7:0) of DAC buffer B
54	0000 0000	Coefficient C27(15:8) of DAC buffer B
55	0000 0000	Coefficient C27(7:0) of DAC buffer B
56	0000 0000	Coefficient C28(15:8) of DAC buffer B
57	0000 0000	Coefficient C28(7:0) of DAC buffer B
58	0000 0000	Coefficient C29(15:8) of DAC buffer B
59	0000 0000	Coefficient C29(7:0) of DAC buffer B
60	0000 0000	Coefficient C30(15:8) of DAC buffer B
61	0000 0000	Coefficient C30(7:0) of DAC buffer B
62	0000 0000	Coefficient C31(15:8) of DAC buffer B
63	0000 0000	Coefficient C31(7:0) of DAC buffer B
64	0000 0000	Coefficient C32(15:8) of DAC buffer B
65	0000 0000	Coefficient C32(7:0) of DAC buffer B
66	0111 1111	Coefficient C33(15:8) of DAC buffer B
67	1111 1111	Coefficient C33(7:0) of DAC buffer B
68	0000 0000	Coefficient C34(15:8) of DAC buffer B
69	0000 0000	Coefficient C34(7:0) of DAC buffer B
70	0000 0000	Coefficient C35(15:8) of DAC buffer B
71	0000 0000	Coefficient C35(7:0) of DAC buffer B
72	0000 0000	Coefficient C36(15:8) of DAC buffer B
73	0000 0000	Coefficient C36(7:0) of DAC buffer B
74	0000 0000	Coefficient C37(15:8) of DAC buffer B

Table 6-9. Page 12 Registers (continued)

REGISTER NUMBER	RESET VALUE	REGISTER NAME
75	0000 0000	Coefficient C37(7:0) of DAC buffer B
76	0111 1111	Coefficient C38(15:8) of DAC buffer B
77	1111 1111	Coefficient C38(7:0) of DAC buffer B
78	0000 0000	Coefficient C39(15:8) of DAC buffer B
79	0000 0000	Coefficient C39(7:0) of DAC buffer B
80	0000 0000	Coefficient C40(15:8) of DAC buffer B
81	0000 0000	Coefficient C40(7:0) of DAC buffer B
82	0000 0000	Coefficient C41(15:8) of DAC buffer B
83	0000 0000	Coefficient C41(7:0) of DAC buffer B
84	0000 0000	Coefficient C42(15:8) of DAC buffer B
85	0000 0000	Coefficient C42(7:0) of DAC buffer B
86	0111 1111	Coefficient C43(15:8) of DAC buffer B
87	1111 1111	Coefficient C43(7:0) of DAC buffer B
88	0000 0000	Coefficient C44(15:8) of DAC buffer B
89	0000 0000	Coefficient C44(7:0) of DAC buffer B
90	0000 0000	Coefficient C45(15:8) of DAC buffer B
91	0000 0000	Coefficient C45(7:0) of DAC buffer B
92	0000 0000	Coefficient C46(15:8) of DAC buffer B
93	0000 0000	Coefficient C46(7:0) of DAC buffer B
94	0000 0000	Coefficient C47(15:8) of DAC buffer B
95	0000 0000	Coefficient C47(7:0) of DAC buffer B
96	0111 1111	Coefficient C48(15:8) of DAC buffer B
97	1111 1111	Coefficient C48(7:0) of DAC buffer B
98	0000 0000	Coefficient C49(15:8) of DAC buffer B
99	0000 0000	Coefficient C49(7:0) of DAC buffer B
100	0000 0000	Coefficient C50(15:8) of DAC buffer B
101	0000 0000	Coefficient C50(7:0) of DAC buffer B
102	0000 0000	Coefficient C51(15:8) of DAC buffer B
103	0000 0000	Coefficient C51(7:0) of DAC buffer B
104	0000 0000	Coefficient C52(15:8) of DAC buffer B
105	0000 0000	Coefficient C52(7:0) of DAC buffer B
106	0111 1111	Coefficient C53(15:8) of DAC buffer B
107	1111 1111	Coefficient C53(7:0) of DAC buffer B
108	0000 0000	Coefficient C54(15:8) of DAC buffer B
109	0000 0000	Coefficient C54(7:0) of DAC buffer B
110	0000 0000	Coefficient C55(15:8) of DAC buffer B
111	0000 0000	Coefficient C55(7:0) of DAC buffer B
112	0000 0000	Coefficient C56(15:8) of DAC buffer B
113	0000 0000	Coefficient C56(7:0) of DAC buffer B
114	0000 0000	Coefficient C57(15:8) of DAC buffer B
115	0000 0000	Coefficient C57(7:0) of DAC buffer B
116	0111 1111	Coefficient C58(15:8) of DAC buffer B
117	1111 1111	Coefficient C58(7:0) of DAC buffer B
118	0000 0000	Coefficient C59(15:8) of DAC buffer B
119	0000 0000	Coefficient C59(7:0) of DAC buffer B
120	0000 0000	Coefficient C60(15:8) of DAC buffer B
121	0000 0000	Coefficient C60(7:0) of DAC buffer B

Table 6-9. Page 12 Registers (continued)

REGISTER NUMBER	RESET VALUE	REGISTER NAME
122	0000 0000	Coefficient C61(15:8) of DAC buffer B
123	0000 0000	Coefficient C61(7:0) of DAC buffer B
124	0000 0000	Coefficient C62(15:8) of DAC buffer B
125	0000 0000	Coefficient C62(7:0) of DAC buffer B
126	0000 0000	Coefficient C63(15:8) of DAC buffer B
127	0000 0000	Coefficient C63(7:0) of DAC buffer B

6.12 Control Registers, Page 13: DAC Programmable Coefficients RAM Buffer B (65:127)
Table 6-10. Page 13 Registers

REGISTER NUMBER	RESET VALUE	REGISTER NAME
1	0000 0000	Reserved. Do not write to this register.
2	0111 1111	Coefficient C65(15:8) of DAC buffer B
3	1111 1111	Coefficient C65(7:0) of DAC buffer B
4	0000 0000	Coefficient C66(15:8) of DAC buffer B
5	0000 0000	Coefficient C66(7:0) of DAC buffer B
6	0000 0000	Coefficient C67(15:8) of DAC buffer B
7	0000 0000	Coefficient C67(7:0) of DAC buffer B
8	0111 1111	Coefficient C68(15:8) of DAC buffer B
9	1111 1111	Coefficient C68(7:0) of DAC buffer B
10	0000 0000	Coefficient C69(15:8) of DAC buffer B
11	0000 0000	Coefficient C69(7:0) of DAC buffer B
12	0000 0000	Coefficient C70(15:8) of DAC buffer B
13	0000 0000	Coefficient C70(7:0) of DAC buffer B
14	0111 1111	Coefficient C71(15:8) of DAC buffer B
15	1111 0111	Coefficient C71(7:0) of DAC buffer B
16	1000 0000	Coefficient C72(15:8) of DAC buffer B
17	0000 1001	Coefficient C72(7:0) of DAC buffer B
18	0111 1111	Coefficient C73(15:8) of DAC buffer B
19	1110 1111	Coefficient C73(7:0) of DAC buffer B
20	0000 0000	Coefficient C74(15:8) of DAC buffer B
21	0001 0001	Coefficient C74(7:0) of DAC buffer B
22	0000 0000	Coefficient C75(15:8) of DAC buffer B
23	0001 0001	Coefficient C75(7:0) of DAC buffer B
24	0111 1111	Coefficient C76(15:8) of DAC buffer B
25	1101 1110	Coefficient C76(7:0) of DAC buffer B
26	0000 0000	Coefficient C77(15:8) of DAC buffer B
27	0000 0000	Coefficient C77(7:0) of DAC buffer B
28	0000 0000	Coefficient C78(15:8) of DAC buffer B
29	0000 0000	Coefficient C78(7:0) of DAC buffer B
30	0000 0000	Coefficient C79(15:8) of DAC buffer B
31	0000 0000	Coefficient C79(7:0) of DAC buffer B
32	0000 0000	Coefficient C80(15:8) of DAC buffer B
33	0000 0000	Coefficient C80(7:0) of DAC buffer B

Table 6-10. Page 13 Registers (continued)

REGISTER NUMBER	RESET VALUE	REGISTER NAME
34	0000 0000	Coefficient C81(15:8) of DAC buffer B
35	0000 0000	Coefficient C81(7:0) of DAC buffer B
36	0000 0000	Coefficient C82(15:8) of DAC buffer B
37	0000 0000	Coefficient C82(7:0) of DAC buffer B
38	0000 0000	Coefficient C83(15:8) of DAC buffer B
39	0000 0000	Coefficient C83(7:0) of DAC buffer B
40	0000 0000	Coefficient C84(15:8) of DAC buffer B
41	0000 0000	Coefficient C84(7:0) of DAC buffer B
42	0000 0000	Coefficient C85(15:8) of DAC buffer B
43	0000 0000	Coefficient C85(7:0) of DAC buffer B
44	0000 0000	Coefficient C86(15:8) of DAC buffer B
45	0000 0000	Coefficient C86(7:0) of DAC buffer B
46	0000 0000	Coefficient C87(15:8) of DAC buffer B
47	0000 0000	Coefficient C87(7:0) of DAC buffer B
48	0000 0000	Coefficient C88(15:8) of DAC buffer B
49	0000 0000	Coefficient C88(7:0) of DAC buffer B
50	0000 0000	Coefficient C89(15:8) of DAC buffer B
51	0000 0000	Coefficient C89(7:0) of DAC buffer B
52	0000 0000	Coefficient C90(15:8) of DAC buffer B
53	0000 0000	Coefficient C90(7:0) of DAC buffer B
54	0000 0000	Coefficient C91(15:8) of DAC buffer B
55	0000 0000	Coefficient C91(7:0) of DAC buffer B
56	0000 0000	Coefficient C92(15:8) of DAC buffer B
57	0000 0000	Coefficient C92(7:0) of DAC buffer B
58	0000 0000	Coefficient C93(15:8) of DAC buffer B
59	0000 0000	Coefficient C93(7:0) of DAC buffer B
60	0000 0000	Coefficient C94(15:8) of DAC buffer B
61	0000 0000	Coefficient C94(7:0) of DAC buffer B
62	0000 0000	Coefficient C95(15:8) of DAC buffer B
63	0000 0000	Coefficient C95(7:0) of DAC buffer B
64	0000 0000	Coefficient C96(15:8) of DAC buffer B
65	0000 0000	Coefficient C96(7:0) of DAC buffer B
66	0000 0000	Coefficient C97(15:8) of DAC buffer B
67	0000 0000	Coefficient C97(7:0) of DAC buffer B
68	0000 0000	Coefficient C98(15:8) of DAC buffer B
69	0000 0000	Coefficient C98(7:0) of DAC buffer B
70	0000 0000	Coefficient C99(15:8) of DAC buffer B
71	0000 0000	Coefficient C99(7:0) of DAC buffer B
72	0000 0000	Coefficient C100(15:8) of DAC buffer B
73	0000 0000	Coefficient C100(7:0) of DAC buffer B
74	0000 0000	Coefficient C101(15:8) of DAC buffer B
75	0000 0000	Coefficient C101(7:0) of DAC buffer B
76	0000 0000	Coefficient C102(15:8) of DAC buffer B
77	0000 0000	Coefficient C102(7:0) of DAC buffer B
78	0000 0000	Coefficient C103(15:8) of DAC buffer B
79	0000 0000	Coefficient C103(7:0) of DAC buffer B
80	0000 0000	Coefficient C104(15:8) of DAC buffer B

Table 6-10. Page 13 Registers (continued)

REGISTER NUMBER	RESET VALUE	REGISTER NAME
81	0000 0000	Coefficient C104(7:0) of DAC buffer B
82	0000 0000	Coefficient C105(15:8) of DAC buffer B
83	0000 0000	Coefficient C105(7:0) of DAC buffer B
84	0000 0000	Coefficient C106(15:8) of DAC buffer B
85	0000 0000	Coefficient C106(7:0) of DAC buffer B
86	0000 0000	Coefficient C107(15:8) of DAC buffer B
87	0000 0000	Coefficient C107(7:0) of DAC buffer B
88	0000 0000	Coefficient C108(15:8) of DAC buffer B
89	0000 0000	Coefficient C108(7:0) of DAC buffer B
90	0000 0000	Coefficient C109(15:8) of DAC buffer B
91	0000 0000	Coefficient C109(7:0) of DAC buffer B
92	0000 0000	Coefficient C110(15:8) of DAC buffer B
93	0000 0000	Coefficient C110(7:0) of DAC buffer B
94	0000 0000	Coefficient C111(15:8) of DAC buffer B
95	0000 0000	Coefficient C111(7:0) of DAC buffer B
96	0000 0000	Coefficient C112(15:8) of DAC buffer B
97	0000 0000	Coefficient C112(7:0) of DAC buffer B
98	0000 0000	Coefficient C113(15:8) of DAC buffer B
99	0000 0000	Coefficient C113(7:0) of DAC buffer B
100	0000 0000	Coefficient C114(15:8) of DAC buffer B
101	0000 0000	Coefficient C114(7:0) of DAC buffer B
102	0000 0000	Coefficient C115(15:8) of DAC buffer B
103	0000 0000	Coefficient C116(7:0) of DAC buffer B
104	0000 0000	Coefficient C117(15:8) of DAC buffer B
105	0000 0000	Coefficient C117(7:0) of DAC buffer B
106	0000 0000	Coefficient C118(15:8) of DAC buffer B
107	0000 0000	Coefficient C118(7:0) of DAC buffer B
108	0000 0000	Coefficient C119(15:8) of DAC buffer B
109	0000 0000	Coefficient C119(7:0) of DAC buffer B
110	0000 0000	Coefficient C120(15:8) of DAC buffer B
111	0000 0000	Coefficient C120(7:0) of DAC buffer B
112	0000 0000	Coefficient C121(15:8) of DAC buffer B
113	0000 0000	Coefficient C121(7:0) of DAC buffer B
114	0000 0000	Coefficient C122(15:8) of DAC buffer B
115	0000 0000	Coefficient C122(7:0) of DAC buffer B
116	0000 0000	Coefficient C123(15:8) of DAC buffer B
117	0000 0000	Coefficient C123(7:0) of DAC buffer B
118	0000 0000	Coefficient C123(15:8) of DAC buffer B
119	0000 0000	Coefficient C123(7:0) of DAC buffer B
120	0000 0000	Coefficient C124(15:8) of DAC buffer B
121	0000 0000	Coefficient C124(7:0) of DAC buffer B
122	0000 0000	Coefficient C125(15:8) of DAC buffer B
123	0000 0000	Coefficient C125(7:0) of DAC buffer B
124	0000 0000	Coefficient C126(15:8) of DAC buffer B
125	0000 0000	Coefficient C126(7:0) of DAC buffer B
126	0000 0000	Coefficient C127(15:8) of DAC buffer B
127	0000 0000	Coefficient C127(7:0) of DAC buffer B

6.13 Control Registers, Page 14: DAC Programmable Coefficients RAM Buffer A (129:191)

Table 6-11. Page 14 Registers

REGISTER NUMBER	RESET VALUE	REGISTER NAME
1	XXXX XXXX	Reserved. Do not write to this register.
2	0000 0000	Coefficient C129(15:8) of DAC buffer B
3	0000 0000	Coefficient C129(7:0) of DAC buffer B
4	0000 0000	Coefficient C130(15:8) of DAC buffer B
5	0000 0000	Coefficient C130(7:0) of DAC buffer B
6	0000 0000	Coefficient C131(15:8) of DAC buffer B
7	0000 0000	Coefficient C131(7:0) of DAC buffer B
8	0000 0000	Coefficient C132(15:8) of DAC buffer B
9	0000 0000	Coefficient C132(7:0) of DAC buffer B
10	0000 0000	Coefficient C133(15:8) of DAC buffer B
11	0000 0000	Coefficient C133(7:0) of DAC buffer B
12	0000 0000	Coefficient C134(15:8) of DAC buffer B
13	0000 0000	Coefficient C134(7:0) of DAC buffer B
14	0000 0000	Coefficient C135(15:8) of DAC buffer B
15	0000 0000	Coefficient C135(7:0) of DAC buffer B
16	0000 0000	Coefficient C136(15:8) of DAC buffer B
17	0000 0000	Coefficient C136(7:0) of DAC buffer B
18	0000 0000	Coefficient C137(15:8) of DAC buffer B
19	0000 0000	Coefficient C137(7:0) of DAC buffer B
20	0000 0000	Coefficient C138(15:8) of DAC buffer B
21	0000 0000	Coefficient C138(7:0) of DAC buffer B
22	0000 0000	Coefficient C139(15:8) of DAC buffer B
23	0000 0000	Coefficient C139(7:0) of DAC buffer B
24	0000 0000	Coefficient C140(15:8) of DAC buffer B
25	0000 0000	Coefficient C140(7:0) of DAC buffer B
26	0000 0000	Coefficient C141(15:8) of DAC buffer B
27	0000 0000	Coefficient C141(7:0) of DAC buffer B
28	0000 0000	Coefficient C142(15:8) of DAC buffer B
29	0000 0000	Coefficient C142(7:0) of DAC buffer B
30	0000 0000	Coefficient C143(15:8) of DAC buffer B
31	0000 0000	Coefficient C143(7:0) of DAC buffer B
32	0000 0000	Coefficient C144(15:8) of DAC buffer B
33	0000 0000	Coefficient C144(7:0) of DAC buffer B
34	0000 0000	Coefficient C145(15:8) of DAC buffer B
35	0000 0000	Coefficient C145(7:0) of DAC buffer B
36	0000 0000	Coefficient C146(15:8) of DAC buffer B
37	0000 0000	Coefficient C146(7:0) of DAC buffer B
38	0000 0000	Coefficient C147(15:8) of DAC buffer B
39	0000 0000	Coefficient C147(7:0) of DAC buffer B
40	0000 0000	Coefficient C148(15:8) of DAC buffer B
41	0000 0000	Coefficient C148(7:0) of DAC buffer B
42	0000 0000	Coefficient C149(15:8) of DAC buffer B
43	0000 0000	Coefficient C149(7:0) of DAC buffer B

Table 6-11. Page 14 Registers (continued)

REGISTER NUMBER	RESET VALUE	REGISTER NAME
44	0000 0000	Coefficient C150(15:8) of DAC buffer B
45	0000 0000	Coefficient C150(7:0) of DAC buffer B
46	0000 0000	Coefficient C151(15:8) of DAC buffer B
47	0000 0000	Coefficient C151(7:0) of DAC buffer B
48	0000 0000	Coefficient C152(15:8) of DAC buffer B
49	0000 0000	Coefficient C152(7:0) of DAC buffer B
50	0000 0000	Coefficient C153(15:8) of DAC buffer B
51	0000 0000	Coefficient C153(7:0) of DAC buffer B
52	0000 0000	Coefficient C154(15:8) of DAC buffer B
53	0000 0000	Coefficient C154(7:0) of DAC buffer B
54	0000 0000	Coefficient C155(15:8) of DAC buffer B
55	0000 0000	Coefficient C155(7:0) of DAC buffer B
56	0000 0000	Coefficient C156(15:8) of DAC buffer B
57	0000 0000	Coefficient C156(7:0) of DAC buffer B
58	0000 0000	Coefficient C157(15:8) of DAC buffer B
59	0000 0000	Coefficient C157(7:0) of DAC buffer B
60	0000 0000	Coefficient C158(15:8) of DAC buffer B
61	0000 0000	Coefficient C158(7:0) of DAC buffer B
62	0000 0000	Coefficient C159(15:8) of DAC buffer B
63	0000 0000	Coefficient C159(7:0) of DAC buffer B
64	0000 0000	Coefficient C160(15:8) of DAC buffer B
65	0000 0000	Coefficient C160(7:0) of DAC buffer B
66	0000 0000	Coefficient C161(15:8) of DAC buffer B
67	0000 0000	Coefficient C161(7:0) of DAC buffer B
68	0000 0000	Coefficient C162(15:8) of DAC buffer B
69	0000 0000	Coefficient C162(7:0) of DAC buffer B
70	0000 0000	Coefficient C163(15:8) of DAC buffer B
71	0000 0000	Coefficient C163(7:0) of DAC buffer B
72	0000 0000	Coefficient C164(15:8) of DAC buffer B
73	0000 0000	Coefficient C164(7:0) of DAC buffer B
74	0000 0000	Coefficient C165(15:8) of DAC buffer B
75	0000 0000	Coefficient C165(7:0) of DAC buffer B
76	0000 0000	Coefficient C166(15:8) of DAC buffer B
77	0000 0000	Coefficient C166(7:0) of DAC buffer B
78	0000 0000	Coefficient C167(15:8) of DAC buffer B
79	0000 0000	Coefficient C167(7:0) of DAC buffer B
80	0000 0000	Coefficient C168(15:8) of DAC buffer B
81	0000 0000	Coefficient C168(7:0) of DAC buffer B
82	0000 0000	Coefficient C169(15:8) of DAC buffer B
83	0000 0000	Coefficient C169(7:0) of DAC buffer B
84	0000 0000	Coefficient C170(15:8) of DAC buffer B
85	0000 0000	Coefficient C170(7:0) of DAC buffer B
86	0000 0000	Coefficient C171(15:8) of DAC buffer B
87	0000 0000	Coefficient C171(7:0) of DAC buffer B
88	0000 0000	Coefficient C172(15:8) of DAC buffer B
89	0000 0000	Coefficient C172(7:0) of DAC buffer B
90	0000 0000	Coefficient C173(15:8) of DAC buffer B

Table 6-11. Page 14 Registers (continued)

REGISTER NUMBER	RESET VALUE	REGISTER NAME
91	0000 0000	Coefficient C173(7:0) of DAC buffer B
92	0000 0000	Coefficient C174(15:8) of DAC buffer B
93	0000 0000	Coefficient C174(7:0) of DAC buffer B
94	0000 0000	Coefficient C175(15:8) of DAC buffer B
95	0000 0000	Coefficient C175(7:0) of DAC buffer B
96	0000 0000	Coefficient C176(15:8) of DAC buffer B
97	0000 0000	Coefficient C176(7:0) of DAC buffer B
98	0000 0000	Coefficient C177(15:8) of DAC buffer B
99	0000 0000	Coefficient C177(7:0) of DAC buffer B
100	0000 0000	Coefficient C178(15:8) of DAC buffer B
101	0000 0000	Coefficient C178(7:0) of DAC buffer B
102	0000 0000	Coefficient C179(15:8) of DAC buffer B
103	0000 0000	Coefficient C179(7:0) of DAC buffer B
104	0000 0000	Coefficient C180(15:8) of DAC buffer B
105	0000 0000	Coefficient C180(7:0) of DAC buffer B
106	0000 0000	Coefficient C181(15:8) of DAC buffer B
107	0000 0000	Coefficient C181(7:0) of DAC buffer B
108	0000 0000	Coefficient C182(15:8) of DAC buffer B
109	0000 0000	Coefficient C182(7:0) of DAC buffer B
110	0000 0000	Coefficient C183(15:8) of DAC buffer B
111	0000 0000	Coefficient C183(7:0) of DAC buffer B
112	0000 0000	Coefficient C184(15:8) of DAC buffer B
113	0000 0000	Coefficient C184(7:0) of DAC buffer B
114	0000 0000	Coefficient C185(15:8) of DAC buffer B
115	0000 0000	Coefficient C185(7:0) of DAC buffer B
116	0000 0000	Coefficient C186(15:8) of DAC buffer B
117	0000 0000	Coefficient C186(7:0) of DAC buffer B
118	0000 0000	Coefficient C187(15:8) of DAC buffer B
119	0000 0000	Coefficient C187(7:0) of DAC buffer B
120	0000 0000	Coefficient C188(15:8) of DAC buffer B
121	0000 0000	Coefficient C188(7:0) of DAC buffer B
122	0000 0000	Coefficient C189(15:8) of DAC buffer B
123	0000 0000	Coefficient C189(7:0) of DAC buffer B
124	0000 0000	Coefficient C190(15:8) of DAC buffer B
125	0000 0000	Coefficient C190(7:0) of DAC buffer B
126	0000 0000	Coefficient C191(15:8) of DAC buffer B
127	0000 0000	Coefficient C191(7:0) of DAC buffer B

6.14 Control Registers, Page 15: DAC Programmable Coefficients RAM Buffer B (193:255)**Table 6-12. Page 15 Registers**

REGISTER NUMBER	RESET VALUE	REGISTER NAME
1	XXXX XXXX	Reserved. Do not write to this register.
2	0000 0000	Coefficient C193(15:8) of DAC buffer B

Table 6-12. Page 15 Registers (continued)

REGISTER NUMBER	RESET VALUE	REGISTER NAME
3	0000 0000	Coefficient C193(7:0) of DAC buffer B
4	0000 0000	Coefficient C194(15:8) of DAC buffer B
5	0000 0000	Coefficient C194(7:0) of DAC buffer B
6	0000 0000	Coefficient C195(15:8) of DAC buffer B
7	0000 0000	Coefficient C195(7:0) of DAC buffer B
8	0000 0000	Coefficient C196(15:8) of DAC buffer B
9	0000 0000	Coefficient C196(7:0) of DAC buffer B
10	0000 0000	Coefficient C197(15:8) of DAC buffer B
11	0000 0000	Coefficient C197(7:0) of DAC buffer B
12	0000 0000	Coefficient C198(15:8) of DAC buffer B
13	0000 0000	Coefficient C198(7:0) of DAC buffer B
14	0000 0000	Coefficient C199(15:8) of DAC buffer B
15	0000 0000	Coefficient C199(7:0) of DAC buffer B
16	0000 0000	Coefficient C200(15:8) of DAC buffer B
17	0000 0000	Coefficient C200(7:0) of DAC buffer B
18	0000 0000	Coefficient C201(15:8) of DAC buffer B
19	0000 0000	Coefficient C201(7:0) of DAC buffer B
20	0000 0000	Coefficient C202(15:8) of DAC buffer B
21	0000 0000	Coefficient C202(7:0) of DAC buffer B
22	0000 0000	Coefficient C203(15:8) of DAC buffer B
23	0000 0000	Coefficient C203(7:0) of DAC buffer B
24	0000 0000	Coefficient C204(15:8) of DAC buffer B
25	0000 0000	Coefficient C204(7:0) of DAC buffer B
26	0000 0000	Coefficient C205(15:8) of DAC buffer B
27	0000 0000	Coefficient C205(7:0) of DAC buffer B
28	0000 0000	Coefficient C206(15:8) of DAC buffer B
29	0000 0000	Coefficient C206(7:0) of DAC buffer B
30	0000 0000	Coefficient C207(15:8) of DAC buffer B
31	0000 0000	Coefficient C207(7:0) of DAC buffer B
32	0000 0000	Coefficient C208(15:8) of DAC buffer B
33	0000 0000	Coefficient C208(7:0) of DAC buffer B
34	0000 0000	Coefficient C209(15:8) of DAC buffer B
35	0000 0000	Coefficient C209(7:0) of DAC buffer B
36	0000 0000	Coefficient C210(15:8) of DAC buffer B
37	0000 0000	Coefficient C210(7:0) of DAC buffer B
38	0000 0000	Coefficient C211(15:8) of DAC buffer B
39	0000 0000	Coefficient C211(7:0) of DAC buffer B
40	0000 0000	Coefficient C212(15:8) of DAC buffer B
41	0000 0000	Coefficient C212(7:0) of DAC buffer B
42	0000 0000	Coefficient C213(15:8) of DAC buffer B
43	0000 0000	Coefficient C213(7:0) of DAC buffer B
44	0000 0000	Coefficient C214(15:8) of DAC buffer B
45	0000 0000	Coefficient C214(7:0) of DAC buffer B
46	0000 0000	Coefficient C215(15:8) of DAC buffer B
47	0000 0000	Coefficient C215(7:0) of DAC buffer B
48	0000 0000	Coefficient C216(15:8) of DAC buffer B
49	0000 0000	Coefficient C216(7:0) of DAC buffer B

Table 6-12. Page 15 Registers (continued)

REGISTER NUMBER	RESET VALUE	REGISTER NAME
50	0000 0000	Coefficient C217(15:8) of DAC buffer B
51	0000 0000	Coefficient C217(7:0) of DAC buffer B
52	0000 0000	Coefficient C218(15:8) of DAC buffer B
53	0000 0000	Coefficient C218(7:0) of DAC buffer B
54	0000 0000	Coefficient C219(15:8) of DAC buffer B
55	0000 0000	Coefficient C219(7:0) of DAC buffer B
56	0000 0000	Coefficient C220(15:8) of DAC buffer B
57	0000 0000	Coefficient C220(7:0) of DAC buffer B
58	0000 0000	Coefficient C221(15:8) of DAC buffer B
59	0000 0000	Coefficient C221(7:0) of DAC buffer B
60	0000 0000	Coefficient C222(15:8) of DAC buffer B
61	0000 0000	Coefficient C222(7:0) of DAC buffer B
62	0000 0000	Coefficient C223(15:8) of DAC buffer B
63	0000 0000	Coefficient C223(7:0) of DAC buffer B
64	0000 0000	Coefficient C224(15:8) of DAC buffer B
65	0000 0000	Coefficient C224(7:0) of DAC buffer B
66	0000 0000	Coefficient C225(15:8) of DAC buffer B
67	0000 0000	Coefficient C225(7:0) of DAC buffer B
68	0000 0000	Coefficient C226(15:8) of DAC buffer B
69	0000 0000	Coefficient C226(7:0) of DAC buffer B
70	0000 0000	Coefficient C227(15:8) of DAC buffer B
71	0000 0000	Coefficient C227(7:0) of DAC buffer B
72	0000 0000	Coefficient C228(15:8) of DAC buffer B
73	0000 0000	Coefficient C228(7:0) of DAC buffer B
74	0000 0000	Coefficient C229(15:8) of DAC buffer B
75	0000 0000	Coefficient C229(7:0) of DAC buffer B
76	0000 0000	Coefficient C230(15:8) of DAC buffer B
77	0000 0000	Coefficient C230(7:0) of DAC buffer B
78	0000 0000	Coefficient C231(15:8) of DAC buffer B
79	0000 0000	Coefficient C231(7:0) of DAC buffer B
80	0000 0000	Coefficient C232(15:8) of DAC buffer B
81	0000 0000	Coefficient C232(7:0) of DAC buffer B
82	0000 0000	Coefficient C233(15:8) of DAC buffer B
83	0000 0000	Coefficient C233(7:0) of DAC buffer B
84	0000 0000	Coefficient C234(15:8) of DAC buffer B
85	0000 0000	Coefficient C234(7:0) of DAC buffer B
86	0000 0000	Coefficient C235(15:8) of DAC buffer B
87	0000 0000	Coefficient C235(7:0) of DAC buffer B
88	0000 0000	Coefficient C236(15:8) of DAC buffer B
89	0000 0000	Coefficient C236(7:0) of DAC buffer B
90	0000 0000	Coefficient C237(15:8) of DAC buffer B
91	0000 0000	Coefficient C237(7:0) of DAC buffer B
92	0000 0000	Coefficient C238(15:8) of DAC buffer B
93	0000 0000	Coefficient C238(7:0) of DAC buffer B
94	0000 0000	Coefficient C239(15:8) of DAC buffer B
95	0000 0000	Coefficient C239(7:0) of DAC buffer B
96	0000 0000	Coefficient C240(15:8) of DAC buffer B

Table 6-12. Page 15 Registers (continued)

REGISTER NUMBER	RESET VALUE	REGISTER NAME
97	0000 0000	Coefficient C240(7:0) of DAC buffer B
98	0000 0000	Coefficient C241(15:8) of DAC buffer B
99	0000 0000	Coefficient C241(7:0) of DAC buffer B
100	0000 0000	Coefficient C242(15:8) of DAC buffer B
101	0000 0000	Coefficient C242(7:0) of DAC buffer B
102	0000 0000	Coefficient C243(15:8) of DAC buffer B
103	0000 0000	Coefficient C243(7:0) of DAC buffer B
104	0000 0000	Coefficient C244(15:8) of DAC buffer B
105	0000 0000	Coefficient C244(7:0) of DAC buffer B
106	0000 0000	Coefficient C245(15:8) of DAC buffer B
107	0000 0000	Coefficient C245(7:0) of DAC buffer B
108	0000 0000	Coefficient C246(15:8) of DAC buffer B
109	0000 0000	Coefficient C246(7:0) of DAC buffer B
110	0000 0000	Coefficient C247(15:8) of DAC buffer B
111	0000 0000	Coefficient C247(7:0) of DAC buffer B
112	0000 0000	Coefficient C248(15:8) of DAC buffer B
113	0000 0000	Coefficient C248(7:0) of DAC buffer B
114	0000 0000	Coefficient C249(15:8) of DAC buffer B
115	0000 0000	Coefficient C249(7:0) of DAC buffer B
116	0000 0000	Coefficient C250(15:8) of DAC buffer B
117	0000 0000	Coefficient C250(7:0) of DAC buffer B
118	0000 0000	Coefficient C251(15:8) of DAC buffer B
119	0000 0000	Coefficient C251(7:0) of DAC buffer B
120	0000 0000	Coefficient C252(15:8) of DAC buffer B
121	0000 0000	Coefficient C252(7:0) of DAC buffer B
122	0000 0000	Coefficient C253(15:8) of DAC buffer B
123	0000 0000	Coefficient C253(7:0) of DAC buffer B
124	0000 0000	Coefficient C254(15:8) of DAC buffer B
125	0000 0000	Coefficient C254(7:0) of DAC buffer B
126	0000 0000	Coefficient C255(15:8) of DAC buffer B
127	0000 0000	Coefficient C255(7:0) of DAC buffer B

6.15 Control Registers, Page 32: ADC DSP Engine Instruction RAM (0:31)
Page 32/Register 0: Page Control Register

BIT	READ/ WRITE	RESET VALUE	DESCRIPTION
D7–D0	R/W	0000 0000	0000 0000: Page 0 selected 0000 0001: Page 1 selected ... 1111 1110: Page 254 selected 1111 1111: Page 255 selected

Page 32/Register 1: Reserved

BIT	READ/ WRITE	RESET VALUE	DESCRIPTION
D7–D0	R/W	XXXX XXXX	Reserved. Write only the default value to this register

Page 32/Register 2: Inst_0(19:16)

BIT	READ/ WRITE	RESET VALUE	DESCRIPTION
D7–D4	R/W	XXXX	Reserved
D3–D0	R/W	XXXX	Instruction Inst_0(19:16) of ADC miniDSP

Page 32/Register 3: Inst_0(15:8)

BIT	READ/ WRITE	RESET VALUE	DESCRIPTION
D7–D0	R/W	XXXX XXXX	Instruction Inst_0(15:8) of ADC miniDSP

Page 32/Register 4: Inst_0(7:0)

BIT	READ/ WRITE	RESET VALUE	DESCRIPTION
D7–D0	R/W	XXXX XXXX	Instruction Inst_0(7:0) of ADC miniDSP

6.15.1 Page 32/Registers 5–97

The remaining unreserved registers on page 32 are arranged in groups of three, with each group containing the bits of one instruction. The arrangement is the same as that of registers 2–4 for Instruction 0. Registers 5–7, 8–10, 11–13, ..., 95–97 contain instructions 1, 2, 3, ..., 31, respectively.

Page 32/Registers 98–127: Reserved

BIT	READ/ WRITE	RESET VALUE	DESCRIPTION
D7–D0	R/W	XXXX XXXX	Reserved. Write only the default value to this register

6.16 Control Registers, Pages 33–43: ADC DSP Engine Instruction RAM (32:63) Through (352:383)

The structuring of the registers within pages 33–43 is identical to that of page 32. Only the instruction numbers differ. The range of instructions within each page is listed in the following table.

Page	Instructions
33	32 to 63
34	64 to 95
35	96 to 127
36	128 to 159
37	160 to 191
38	192 to 223
39	224 to 255
40	256 to 287
41	288 to 319
42	320 to 351
43	352 to 383

6.17 Control Registers, Page 64: DAC DSP Engine Instruction RAM (0:31)**Page 64/Register 0: Page Control Register**

BIT	READ/ WRITE	RESET VALUE	DESCRIPTION
D7–D0	R/W	0000 0000	0000 0000: Page 0 selected 0000 0001: Page 1 selected ... 1111 1110: Page 254 selected 1111 1111: Page 255 selected

Page 64/Register 1: Reserved

BIT	READ/ WRITE	RESET VALUE	DESCRIPTION
D7–D0	R/W	XXXX XXXX	Reserved. Write only the default value to this register

Page 64/Register 2: Inst_0(23:16)

BIT	READ/ WRITE	RESET VALUE	DESCRIPTION
D7–D0	R/W	XXXX	Instruction Inst_0(23:16) of DAC miniDSP

Page 64/Register 3: Inst_0(15:8)

BIT	READ/ WRITE	RESET VALUE	DESCRIPTION
D7–D0	R/W	XXXX XXXX	Instruction Inst_0(15:8) of DAC miniDSP

Page 64/Register 4: Inst_0(7:0)

BIT	READ/ WRITE	RESET VALUE	DESCRIPTION
D7–D0	R/W	XXXX XXXX	Instruction Inst_0(7:0) of DAC miniDSP

6.17.1 Page 64/Registers 5–97

The remaining unreserved registers on page 32 are arranged in groups of three, with each group containing the bits of one instruction. The arrangement is the same as that of registers 2–4 for Instruction 0. Registers 5–7, 8–10, 11–13, ..., 95–97 contain instructions 1, 2, 3, ..., 31, respectively.

Page 64/Registers 98–127: Reserved

BIT	READ/ WRITE	RESET VALUE	DESCRIPTION
D7–D0	R/W	XXXX XXXX	Reserved. Write only the default value to this register

6.18 Control Registers, Pages 65–95: DAC DSP Engine Instruction RAM (32:63) Through (992:1023)

The structuring of the registers within pages 65–95 is identical to that of page 64. Only the instruction numbers differ. The range of instructions within each page is listed in the following table.

Page	Instructions
65	32 to 63
66	64 to 95
67	96 to 127
68	128 to 159
69	160 to 191
70	192 to 223
71	224 to 255
72	256 to 287
73	288 to 319
74	320 to 351
75	352 to 383
76	384 to 415
77	416 to 447
78	448 to 479
79	480 to 511
80	512 to 543
81	544 to 575
82	576 to 607
83	608 to 639
84	640 to 671
85	672 to 703
86	704 to 735
87	736 to 767
88	768 to 799
89	800 to 831
90	832 to 863
91	864 to 895
92	896 to 927
93	928 to 959
94	960 to 991
95	992 to 1023

6.19 Control Registers, Page 252: SAR Buffer-Mode Data

Page 252/Register 0: Page Control Register

BIT	READ/ WRITE	RESET VALUE	DESCRIPTION
D7–D0	R/W	0000 0000	0000 0000: Page 0 selected 0000 0001: Page 1 selected ... 1111 1110: Page 254 selected 1111 1111: Page 255 selected

Page 252/Register 1: Buffer Mode Data (MSB)

BIT	READ/ WRITE	RESET VALUE	DESCRIPTION
D7–D0	R	XXXX XXXX	Reading this register returns the 8 MSBs of the buffer data based on the RDPTR.

Page 252/Register 2: Buffer Mode Data (LSB)

BIT	READ/ WRITE	RESET VALUE	DESCRIPTION
D7–D0	R	XXXX XXXX	Reading this register returns the 8 LSBs of the buffer data based on the RDPTR.

Page 252/Registers 3 to 127: Reserved

BIT	READ/ WRITE	RESET VALUE	DESCRIPTION
D7–D0	R/W	XXXX XXXX	Reserved. Write only the reset value to these bits.

Revision History

NOTE: Page numbers for previous revisions may differ from page numbers in the current version.

Changes from Revision Original (April 2009) to Revision A		Page
<ul style="list-style-type: none"> Changed 1-W to 1.29-W in Features list 		1
Changes from Revision A (June 2009) to Revision B		Page
<ul style="list-style-type: none"> Added SAR ADC to last para in Description Added Table 5-15 Deleted Analog Volume Control for Headphone and Speaker Outputs (for D7 = 0) table Changed footnote in D7=1 table; added D6–D0 to the Register Value columns, and changed Analog Attenuation to Analog Gain. Changed page 0/register 44, bits D2–D1 to page 1/register 44, bits D2–D1 in second para in Headphone Drivers section Changed Figure 5-58 Added Timer section Added footnote to Page 0/Register 64: DAC VOLUME CONTROL Changed Page 0/Register 83: ADC Digital Volume Control Coarse Adjust Changed Page 1/Register 33: HP Output Drivers POP Removal Settings Bit D0 = 1 to Reserved Added footnote to Page 1/Register 40: HPL Driver Added footnote to Page 1/Register 41: HPR Driver Deleted footnote from Page 1/Register 48: Delta-Sigma Mono ADC Channel Fine-Gain Input Selection for P-Terminal Deleted footnote from Page 1/Register 49: ADC Input Selection for M-Terminal 		2 29 63 63 64 87 91 120 124 130 132 132 134 134

PACKAGING INFORMATION

Orderable Device	Status (1)	Package Type	Package Drawing	Pins	Package Qty	Eco Plan (2)	Lead finish/ Ball material (6)	MSL Peak Temp (3)	Op Temp (°C)	Device Marking (4/5)	Samples
TSC2117IRGZR	ACTIVE	VQFN	RGZ	48	2500	RoHS & Green	NIPDAU	Level-3-260C-168 HR	-40 to 85	TSC2117	Samples
TSC2117IRGZT	ACTIVE	VQFN	RGZ	48	250	RoHS & Green	NIPDAU	Level-3-260C-168 HR	-40 to 85	TSC2117	Samples

(1) The marketing status values are defined as follows:

ACTIVE: Product device recommended for new designs.

LIFEBUY: TI has announced that the device will be discontinued, and a lifetime-buy period is in effect.

NRND: Not recommended for new designs. Device is in production to support existing customers, but TI does not recommend using this part in a new design.

PREVIEW: Device has been announced but is not in production. Samples may or may not be available.

OBSOLETE: TI has discontinued the production of the device.

(2) **RoHS:** TI defines "RoHS" to mean semiconductor products that are compliant with the current EU RoHS requirements for all 10 RoHS substances, including the requirement that RoHS substance do not exceed 0.1% by weight in homogeneous materials. Where designed to be soldered at high temperatures, "RoHS" products are suitable for use in specified lead-free processes. TI may reference these types of products as "Pb-Free".

RoHS Exempt: TI defines "RoHS Exempt" to mean products that contain lead but are compliant with EU RoHS pursuant to a specific EU RoHS exemption.

Green: TI defines "Green" to mean the content of Chlorine (Cl) and Bromine (Br) based flame retardants meet JS709B low halogen requirements of <=1000ppm threshold. Antimony trioxide based flame retardants must also meet the <=1000ppm threshold requirement.

(3) MSL, Peak Temp. - The Moisture Sensitivity Level rating according to the JEDEC industry standard classifications, and peak solder temperature.

(4) There may be additional marking, which relates to the logo, the lot trace code information, or the environmental category on the device.

(5) Multiple Device Markings will be inside parentheses. Only one Device Marking contained in parentheses and separated by a "~" will appear on a device. If a line is indented then it is a continuation of the previous line and the two combined represent the entire Device Marking for that device.

(6) Lead finish/Ball material - Orderable Devices may have multiple material finish options. Finish options are separated by a vertical ruled line. Lead finish/Ball material values may wrap to two lines if the finish value exceeds the maximum column width.

Important Information and Disclaimer:The information provided on this page represents TI's knowledge and belief as of the date that it is provided. TI bases its knowledge and belief on information provided by third parties, and makes no representation or warranty as to the accuracy of such information. Efforts are underway to better integrate information from third parties. TI has taken and continues to take reasonable steps to provide representative and accurate information but may not have conducted destructive testing or chemical analysis on incoming materials and chemicals. TI and TI suppliers consider certain information to be proprietary, and thus CAS numbers and other limited information may not be available for release.

In no event shall TI's liability arising out of such information exceed the total purchase price of the TI part(s) at issue in this document sold by TI to Customer on an annual basis.

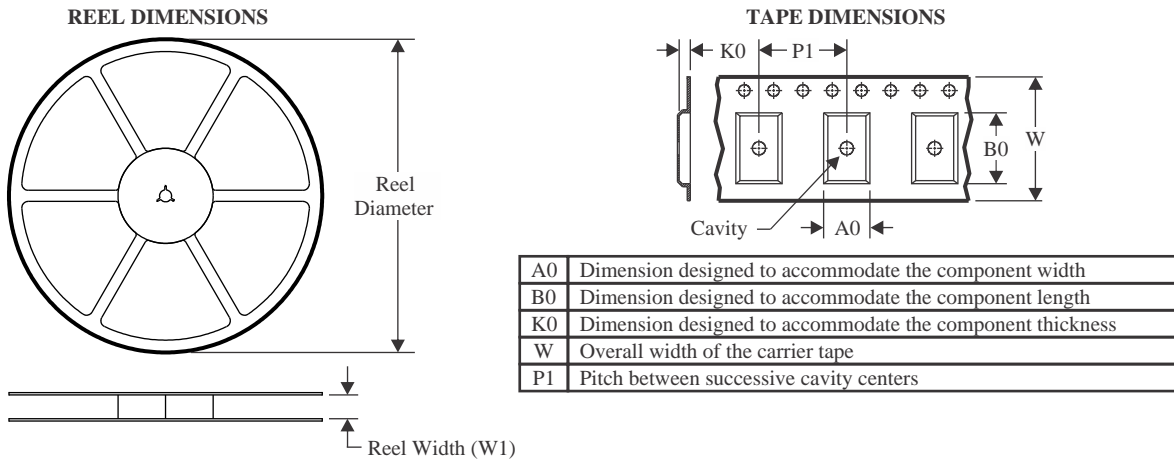
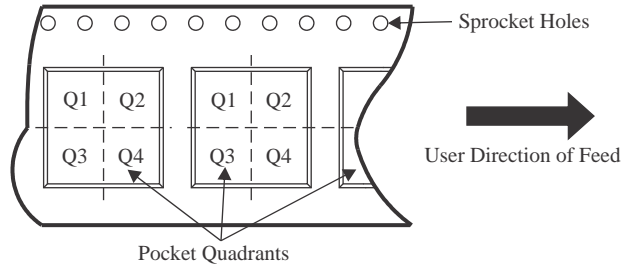
TAPE AND REEL INFORMATION

QUADRANT ASSIGNMENTS FOR PIN 1 ORIENTATION IN TAPE

*All dimensions are nominal

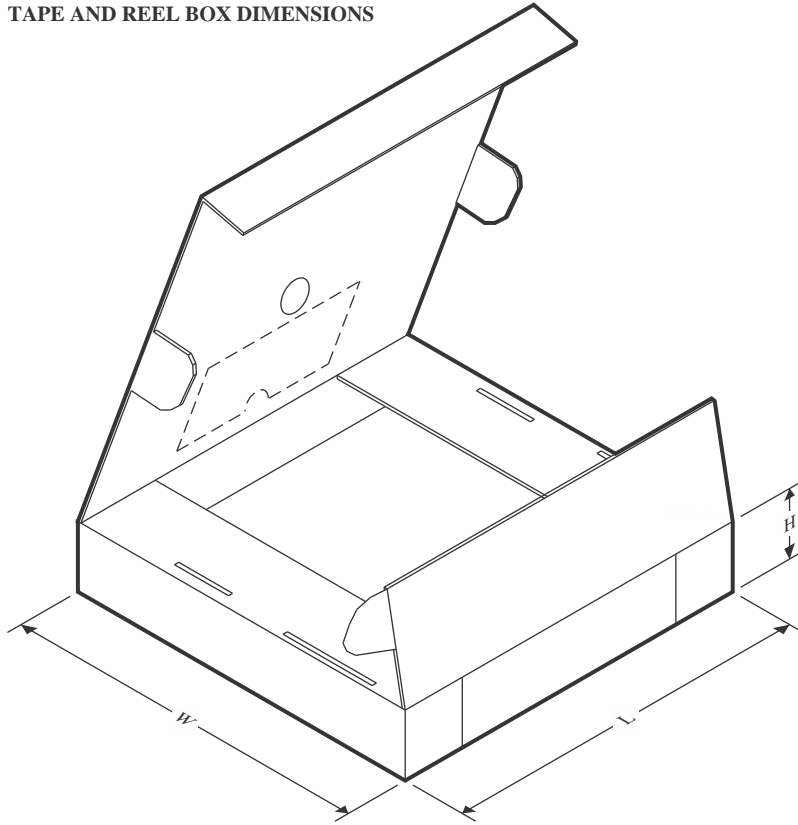
Device	Package Type	Package Drawing	Pins	SPQ	Reel Diameter (mm)	Reel Width W1 (mm)	A0 (mm)	B0 (mm)	K0 (mm)	P1 (mm)	W (mm)	Pin1 Quadrant
TSC2117IRGZR	VQFN	RGZ	48	2500	330.0	16.4	7.3	7.3	1.5	12.0	16.0	Q2
TSC2117IRGZT	VQFN	RGZ	48	250	180.0	16.4	7.3	7.3	1.5	12.0	16.0	Q2

TAPE AND REEL BOX DIMENSIONS

*All dimensions are nominal

Device	Package Type	Package Drawing	Pins	SPQ	Length (mm)	Width (mm)	Height (mm)
TSC2117IRGZR	VQFN	RGZ	48	2500	356.0	356.0	35.0
TSC2117IRGZT	VQFN	RGZ	48	250	210.0	185.0	35.0

GENERIC PACKAGE VIEW

RGZ 48

VQFN - 1 mm max height

7 x 7, 0.5 mm pitch

PLASTIC QUADFLAT PACK- NO LEAD

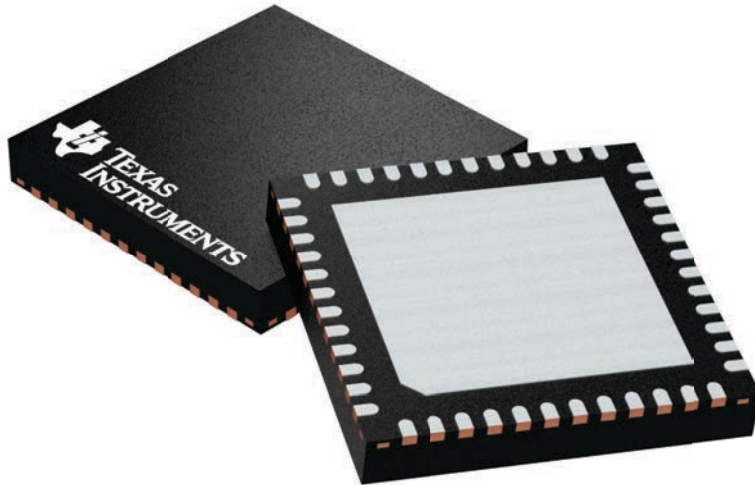

Images above are just a representation of the package family, actual package may vary.
Refer to the product data sheet for package details.

4224671/A

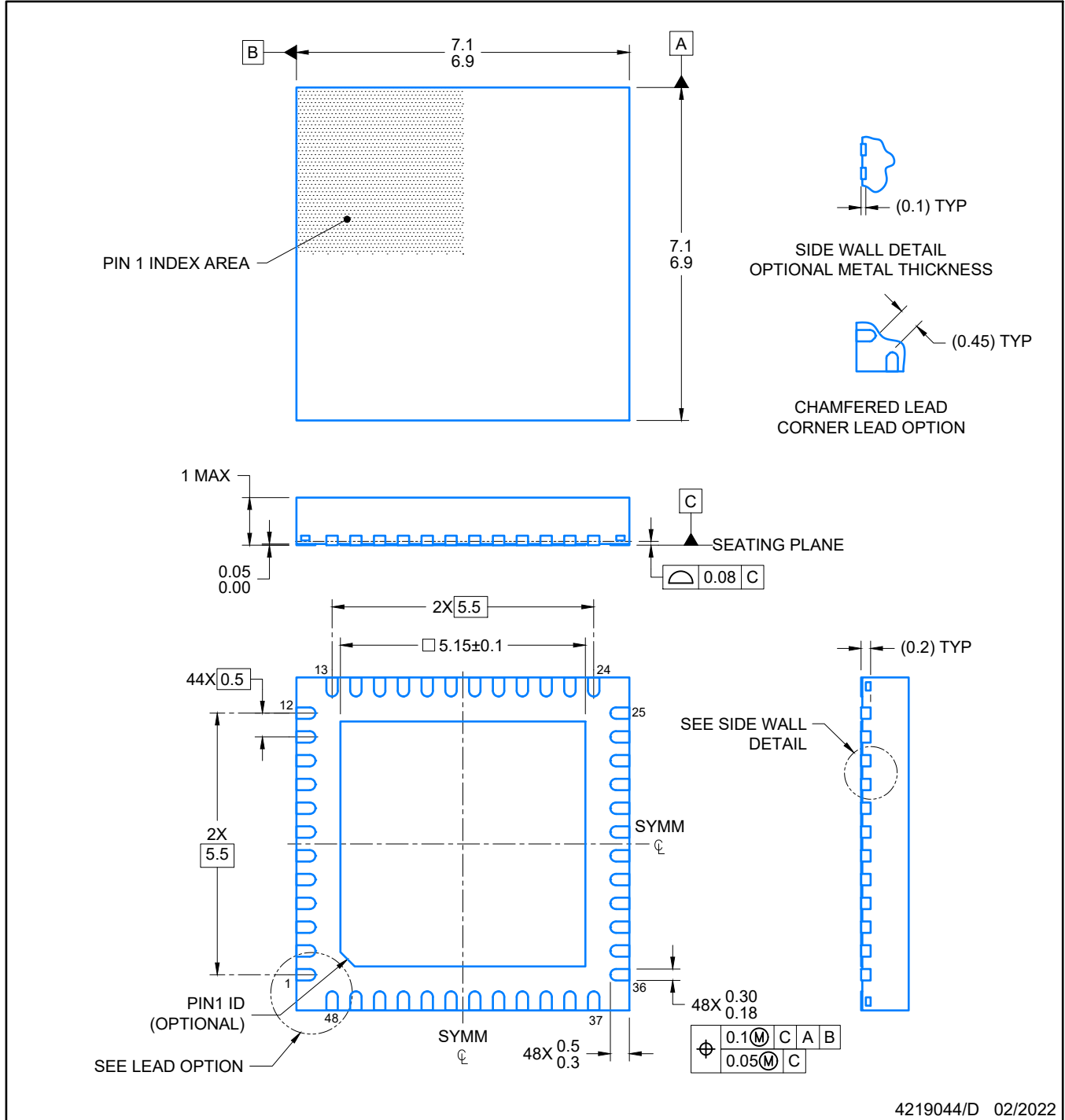

NOTES:

1. All linear dimensions are in millimeters. Any dimensions in parenthesis are for reference only. Dimensioning and tolerancing per ASME Y14.5M.
2. This drawing is subject to change without notice.
3. The package thermal pad must be soldered to the printed circuit board for optimal thermal and mechanical performance.

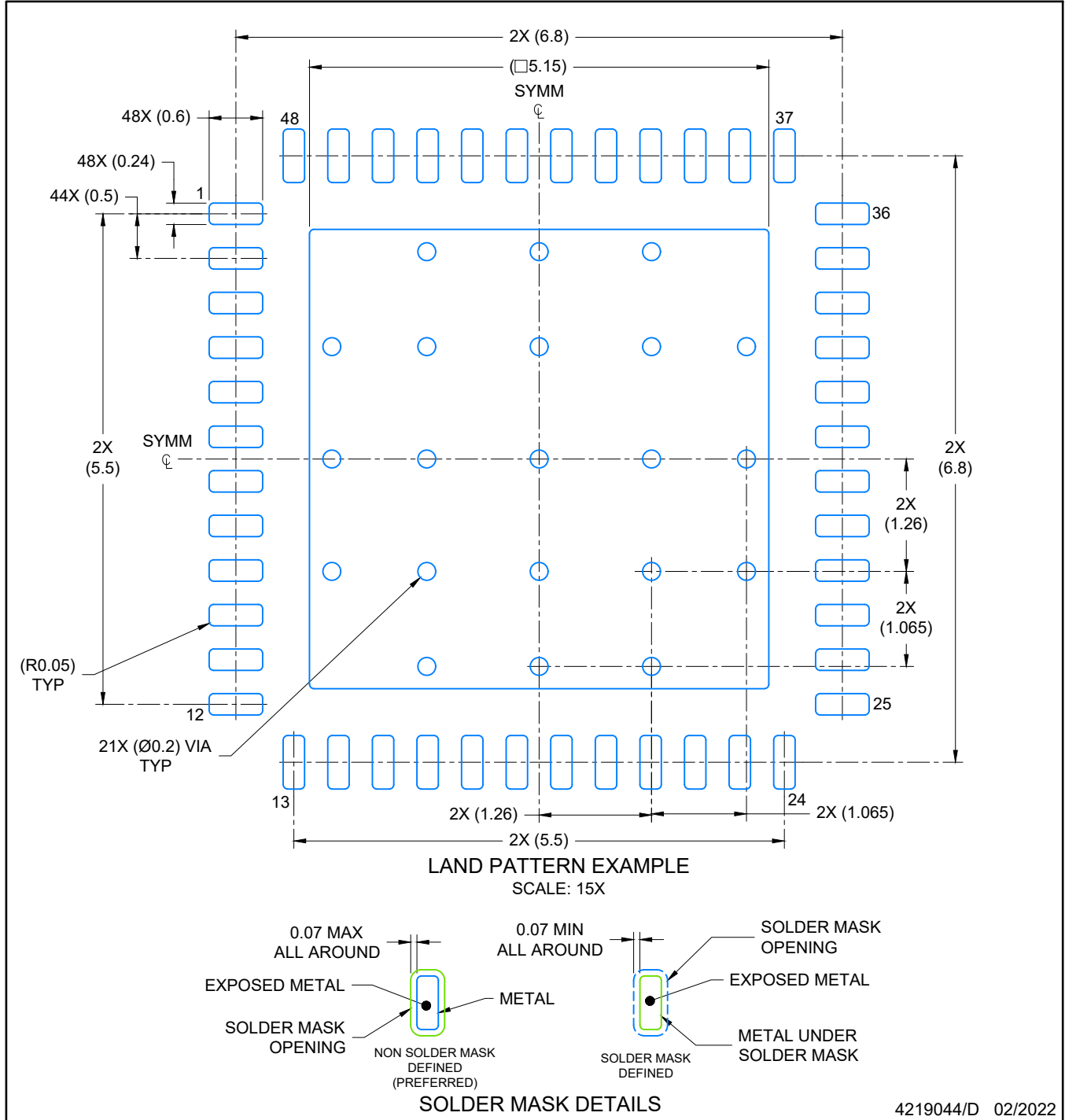

NOTES: (continued)

4. This package is designed to be soldered to a thermal pad on the board. For more information, see Texas Instruments literature number SLUA271 (www.ti.com/lit/slua271).
5. Vias are optional depending on application, refer to device data sheet. If any vias are implemented, refer to their locations shown on this view. It is recommended that vias under paste be filled, plugged or tented.

EXAMPLE STENCIL DESIGN

RGZ0048A

VQFN - 1 mm max height

PLASTIC QUADFLAT PACK- NO LEAD

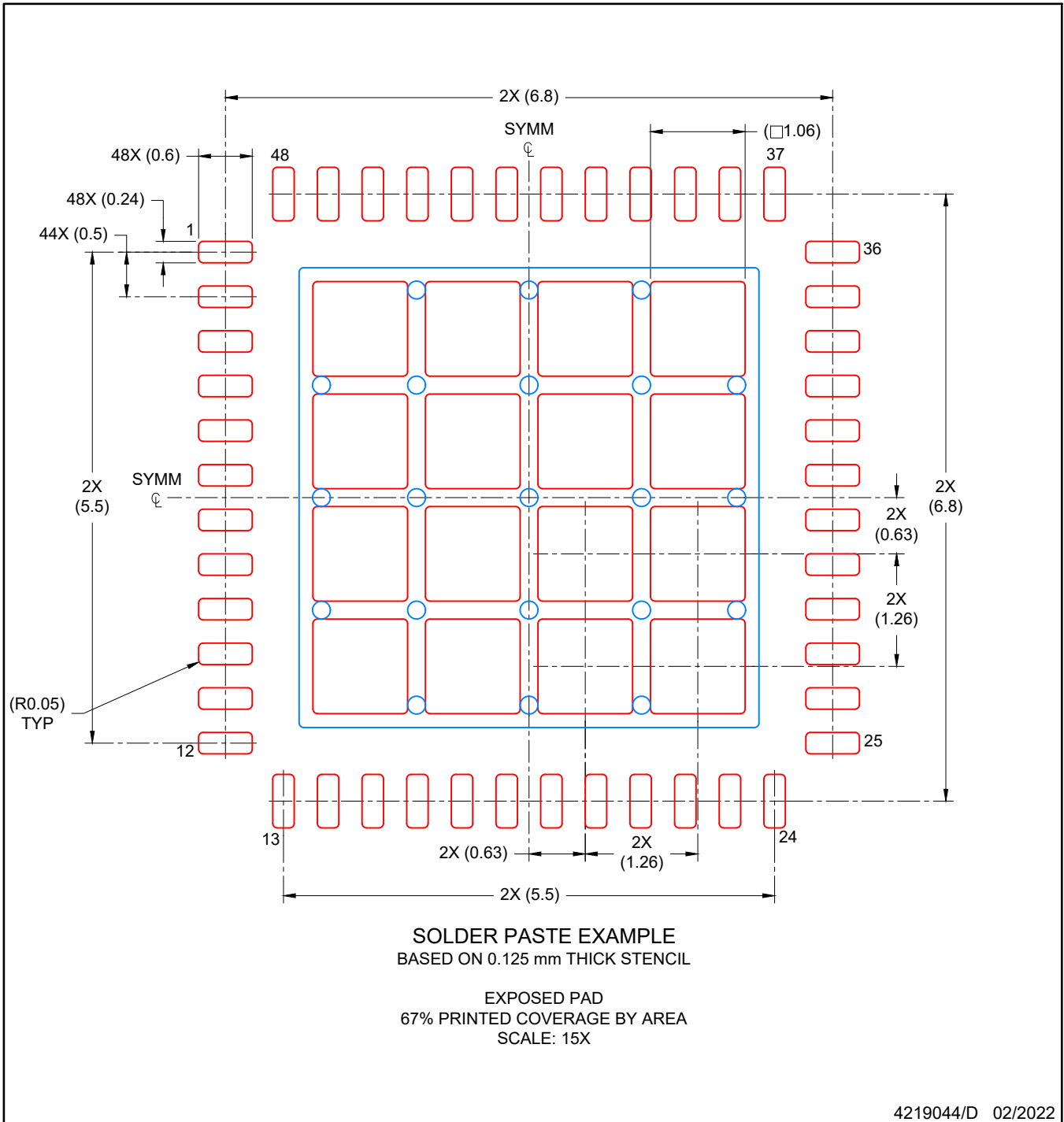

NOTES: (continued)

6. Laser cutting apertures with trapezoidal walls and rounded corners may offer better paste release. IPC-7525 may have alternate design recommendations.

IMPORTANT NOTICE AND DISCLAIMER

TI PROVIDES TECHNICAL AND RELIABILITY DATA (INCLUDING DATA SHEETS), DESIGN RESOURCES (INCLUDING REFERENCE DESIGNS), APPLICATION OR OTHER DESIGN ADVICE, WEB TOOLS, SAFETY INFORMATION, AND OTHER RESOURCES "AS IS" AND WITH ALL FAULTS, AND DISCLAIMS ALL WARRANTIES, EXPRESS AND IMPLIED, INCLUDING WITHOUT LIMITATION ANY IMPLIED WARRANTIES OF MERCHANTABILITY, FITNESS FOR A PARTICULAR PURPOSE OR NON-INFRINGEMENT OF THIRD PARTY INTELLECTUAL PROPERTY RIGHTS.

These resources are intended for skilled developers designing with TI products. You are solely responsible for (1) selecting the appropriate TI products for your application, (2) designing, validating and testing your application, and (3) ensuring your application meets applicable standards, and any other safety, security, regulatory or other requirements.

These resources are subject to change without notice. TI grants you permission to use these resources only for development of an application that uses the TI products described in the resource. Other reproduction and display of these resources is prohibited. No license is granted to any other TI intellectual property right or to any third party intellectual property right. TI disclaims responsibility for, and you will fully indemnify TI and its representatives against, any claims, damages, costs, losses, and liabilities arising out of your use of these resources.

TI's products are provided subject to [TI's Terms of Sale](#) or other applicable terms available either on ti.com or provided in conjunction with such TI products. TI's provision of these resources does not expand or otherwise alter TI's applicable warranties or warranty disclaimers for TI products.

TI objects to and rejects any additional or different terms you may have proposed.

Mailing Address: Texas Instruments, Post Office Box 655303, Dallas, Texas 75265
Copyright © 2022, Texas Instruments Incorporated

Looking for pricing, stock, or lifecycle information?

Click below to explore more details on WIN SOURCE:

 [View TSC2117EVM-K on WIN SOURCE](#)

 [Texas Instruments](#) Information

Optimize Your Supply Chain with WIN SOURCE Solutions

-  Global Sourcing Solution
-  Obsolete Management
-  Cost Control Management
-  Shortage Management
-  Alternative Solution
-  Excess Inventory Management