

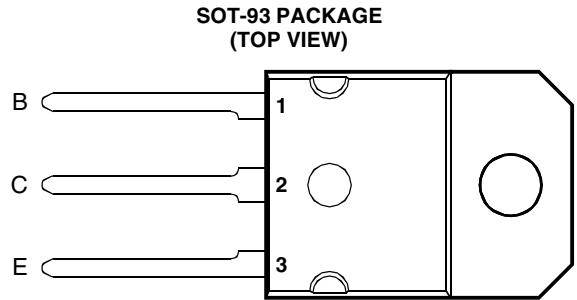

# THE DATASHEET OF TIPL765A-S



- Rugged Triple-Diffused Planar Construction
- 10 A Continuous Collector Current
- Operating Characteristics Fully Guaranteed at 100°C
- 1000 Volt Blocking Capability
- 125 W at 25°C Case Temperature



MDTRAAA

**absolute maximum ratings at 25°C case temperature (unless otherwise noted)**

RATING		SYMBOL	VALUE	UNIT
Collector-base voltage ( $I_E = 0$ )	TIPL765	$V_{CBO}$	850	V
	TIPL765A		1000	
Collector-emitter voltage ( $V_{BE} = 0$ )	TIPL765	$V_{CES}$	850	V
	TIPL765A		1000	
Collector-emitter voltage ( $I_B = 0$ )	TIPL765	$V_{CEO}$	400	V
	TIPL765A		450	
Emitter-base voltage		$V_{EBO}$	10	V
Continuous collector current		$I_C$	10	A
Peak collector current (see Note 1)		$I_{CM}$	15	A
Continuous device dissipation at (or below) 25°C case temperature		$P_{tot}$	125	W
Operating junction temperature range		$T_j$	-65 to +150	°C
Storage temperature range		$T_{stg}$	-65 to +150	°C

NOTE 1: This value applies for  $t_p \leq 10$  ms, duty cycle  $\leq 2\%$ .

**PRODUCT INFORMATION**

AUGUST 1978 - REVISED SEPTEMBER 2002  
Specifications are subject to change without notice.

# TIPL765, TIPL765A NPN SILICON POWER TRANSISTORS

**BOURNS®**

## electrical characteristics at 25°C case temperature (unless otherwise noted)

PARAMETER	TEST CONDITIONS	MIN	TYP	MAX	UNIT
$V_{CEO(sus)}$ Collector-emitter sustaining voltage	$I_C = 100 \text{ mA}$ $L = 25 \text{ mH}$ (see Note 2) TIPL765 TIPL765A	400 450			V
$I_{CES}$ Collector-emitter cut-off current	$V_{CE} = 850 \text{ V}$ $V_{BE} = 0$ $V_{CE} = 1000 \text{ V}$ $V_{BE} = 0$ $V_{CE} = 850 \text{ V}$ $V_{BE} = 0$ $T_C = 100^\circ\text{C}$ $V_{CE} = 1000 \text{ V}$ $V_{BE} = 0$ $T_C = 100^\circ\text{C}$			50 50 200 200	$\mu\text{A}$
$I_{CEO}$ Collector cut-off current	$V_{CE} = 400 \text{ V}$ $I_B = 0$ $V_{CE} = 450 \text{ V}$ $I_B = 0$			50 50	$\mu\text{A}$
$I_{EBO}$ Emitter cut-off current	$V_{EB} = 10 \text{ V}$ $I_C = 0$			1	mA
$h_{FE}$ Forward current transfer ratio	$V_{CE} = 5 \text{ V}$ $I_C = 0.5 \text{ A}$ (see Notes 3 and 4)	15		60	
$V_{CE(sat)}$ Collector-emitter saturation voltage	$I_B = 0.4 \text{ A}$ $I_C = 2 \text{ A}$ $I_B = 1 \text{ A}$ $I_C = 5 \text{ A}$ (see Notes 3 and 4) $I_B = 2 \text{ A}$ $I_C = 10 \text{ A}$ $I_B = 2 \text{ A}$ $I_C = 10 \text{ A}$ $T_C = 100^\circ\text{C}$			0.5 1.0 2.5 5.0	V
$V_{BE(sat)}$ Base-emitter saturation voltage	$I_B = 0.4 \text{ A}$ $I_C = 2 \text{ A}$ $I_B = 1 \text{ A}$ $I_C = 5 \text{ A}$ (see Notes 3 and 4) $I_B = 2 \text{ A}$ $I_C = 10 \text{ A}$ $I_B = 2 \text{ A}$ $I_C = 10 \text{ A}$ $T_C = 100^\circ\text{C}$			1.1 1.3 1.7 1.6	V
$f_t$ Current gain bandwidth product	$V_{CE} = 10 \text{ V}$ $I_C = 0.5 \text{ A}$ $f = 1 \text{ MHz}$		8		MHz
$C_{ob}$ Output capacitance	$V_{CB} = 20 \text{ V}$ $I_E = 0$ $f = 0.1 \text{ MHz}$		150		pF

NOTES: 2. Inductive loop switching measurement.

3. These parameters must be measured using pulse techniques,  $t_p = 300 \mu\text{s}$ , duty cycle  $\leq 2\%$ .

4. These parameters must be measured using voltage-sensing contacts, separate from the current carrying contacts.

## thermal characteristics

PARAMETER	MIN	TYP	MAX	UNIT
$R_{\theta JC}$ Junction to case thermal resistance			1	$^\circ\text{C/W}$

## inductive-load-switching characteristics at 25°C case temperature (unless otherwise noted)

PARAMETER	TEST CONDITIONS †	MIN	TYP	MAX	UNIT
$t_{sv}$ Voltage storage time	$I_C = 10 \text{ A}$ $V_{BE(off)} = -5 \text{ V}$ $I_{B(on)} = 2 \text{ A}$ (see Figures 1 and 2)			2	$\mu\text{s}$
$t_{rv}$ Voltage rise time				300	ns
$t_{fi}$ Current fall time				200	ns
$t_{ti}$ Current tail time				50	ns
$t_{xo}$ Cross over time				400	ns
$t_{sv}$ Voltage storage time	$I_C = 10 \text{ A}$ $V_{BE(off)} = -5 \text{ V}$ $I_{B(on)} = 2 \text{ A}$ $T_C = 100^\circ\text{C}$ (see Figures 1 and 2)			3.5	$\mu\text{s}$
$t_{rv}$ Voltage rise time				400	ns
$t_{fi}$ Current fall time				300	ns
$t_{ti}$ Current tail time				80	ns
$t_{xo}$ Cross over time				500	ns

† Voltage and current values shown are nominal; exact values vary slightly with transistor parameters.

## PRODUCT INFORMATION



TYPICAL CHARACTERISTICS

TYPICAL DC CURRENT GAIN  
vs  
COLLECTOR CURRENT

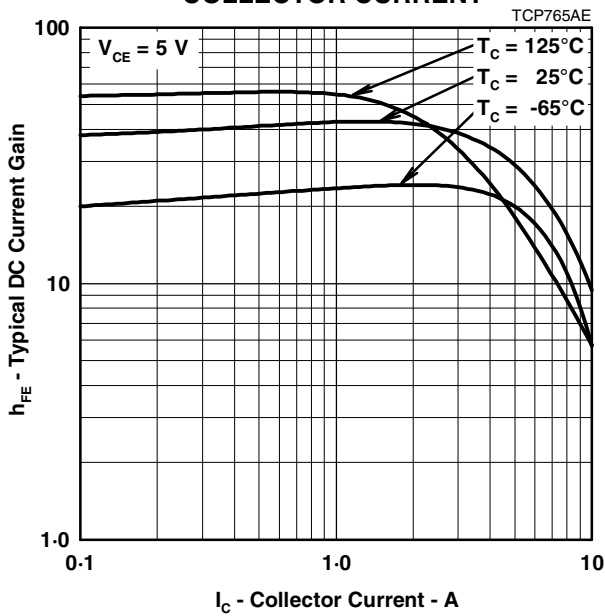

Figure 3.

COLLECTOR-EMITTER SATURATION VOLTAGE  
vs  
BASE CURRENT

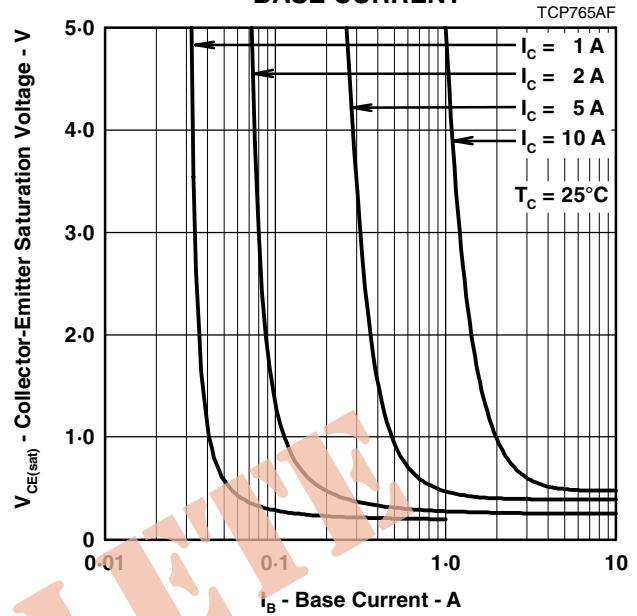

Figure 4.

COLLECTOR-EMITTER SATURATION VOLTAGE  
vs  
BASE CURRENT

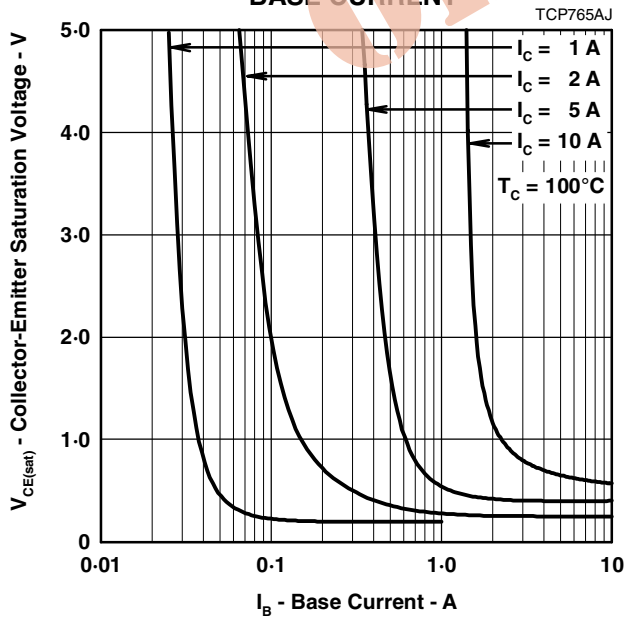

Figure 5.

BASE-EMITTER SATURATION VOLTAGE  
vs  
BASE CURRENT

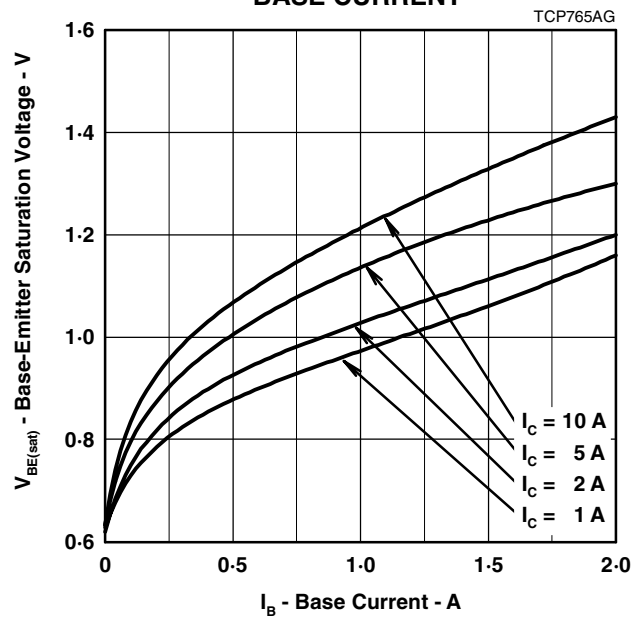

Figure 6.

**PRODUCT INFORMATION**

AUGUST 1978 - REVISED SEPTEMBER 2002  
Specifications are subject to change without notice.

**TYPICAL CHARACTERISTICS**

**COLLECTOR CUT-OFF CURRENT  
vs  
CASE TEMPERATURE**

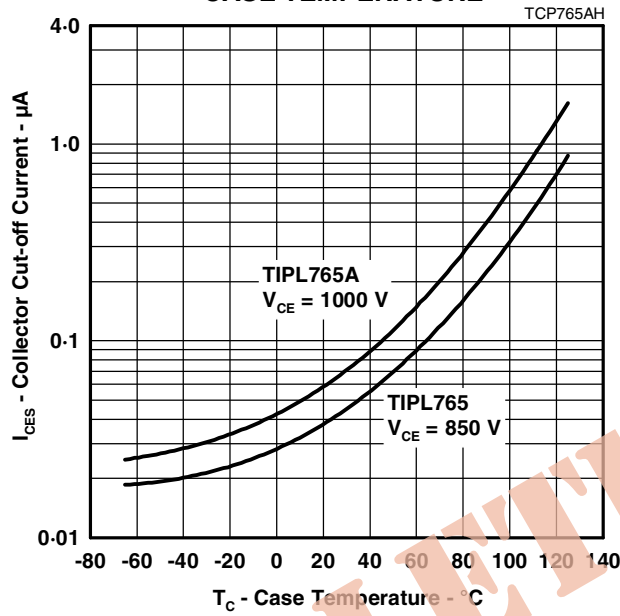

Figure 7.

**MAXIMUM SAFE OPERATING REGIONS**

**MAXIMUM FORWARD-BIAS  
SAFE OPERATING AREA**

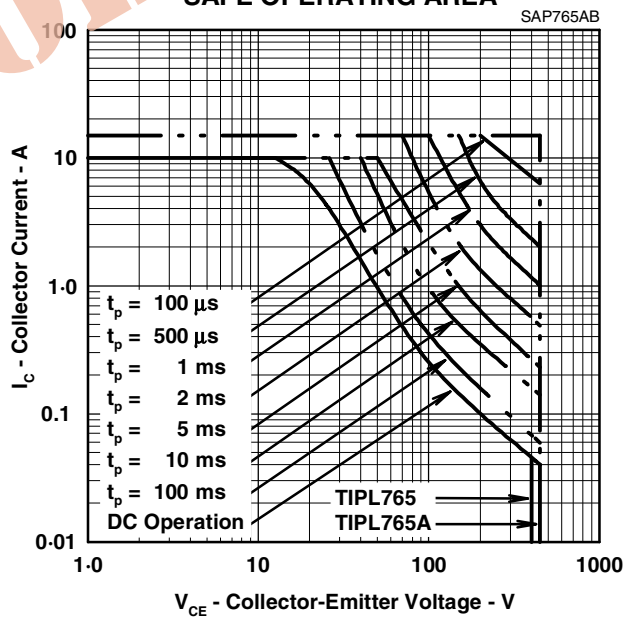

Figure 8.

**PRODUCT INFORMATION**

AUGUST 1978 - REVISED SEPTEMBER 2002  
Specifications are subject to change without notice.

## Looking for pricing, stock, or lifecycle information?

Click below to explore more details on WIN SOURCE:

 [View TIPL765A-S on WIN SOURCE](#)

 [Bourns Inc. Information](#)

## Optimize Your Supply Chain with WIN SOURCE Solutions

-  Global Sourcing Solution
-  Obsolete Management
-  Cost Control Management
-  Shortage Management
-  Alternative Solution
-  Excess Inventory Management