



**THE DATASHEET OF
TL4051A12QDBZTG4**



FEATURES

- 1.225-V Fixed and Adjustable (1.225-V to 10-V) Outputs
- Tight Output Tolerances and Low Temperature Coefficient
 - Max 0.1%, 50 ppm/°C – A Grade
 - Max 0.2%, 50 ppm/°C – B Grade
 - Max 0.5%, 50 ppm/°C – C Grade
- Low Output Noise...20 μV_{RMS} (Typ)
- Wide Operating Current Range... 60 μA (Typ) to 12 mA
- Stable With All Capacitive Loads; No Output Capacitor Required
- Available in
 - Industrial Temperature: -40°C to 85°C
 - Extended Temperature: -40°C to 125°C

APPLICATIONS

- Data-Acquisition Systems
- Power Supplies and Power-Supply Monitors
- Instrumentation and Test Equipment
- Process Control
- Precision Audio
- Automotive Electronics
- Energy Management/Metering
- Battery-Powered Equipment

1.2 V...DBZ (SOT-23-3) PACKAGE
(TOP VIEW)

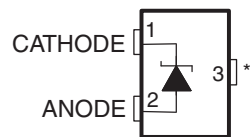

* Pin 3 is attached to Substrate and must be connected to ANODE or left open.

1.2 V...DCK (SC-70) PACKAGE
(TOP VIEW)

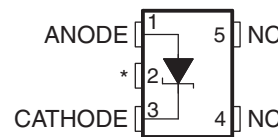

NC – No internal connection

* Pin 2 is attached to Substrate and must be connected to ANODE or left open.

Adjustable...DBZ (SOT-23-3) PACKAGE
(TOP VIEW)

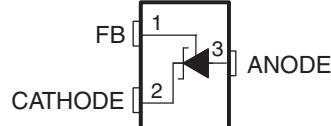

Adjustable...DCK (SC-70) PACKAGE
(TOP VIEW)

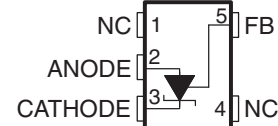

NC – No internal connection

DESCRIPTION/ORDERING INFORMATION

The TL4051 series of shunt voltage references are versatile easy-to-use references suitable for a wide array of applications. The device is available in a fixed 1.225-V output or an adjustable output whose voltage is determined by an external resistor divider. The device requires no external capacitors for operation and is stable with all capacitive loads. Additionally, the reference offers low dynamic impedance, low noise, and low temperature coefficient to ensure a stable output voltage over a wide range of operating currents and temperatures.

The TL4051 is offered in three initial tolerances, ranging from 0.1% (max) for the A grade to 0.5% (max) for the C grade. Thus, a great deal of flexibility is offered to designers in choosing the best cost-to-performance ratio for their applications. Packaged in the space-saving SOT-23-3 and SC-70 packages and requiring a minimum current of 45 μA (typ), the TL4051 also is ideal for portable applications.

The TL4051xl is characterized for operation over an ambient temperature range of -40°C to 85°C . The TL4051xQ is characterized for operation over an ambient temperature range of -40°C to 125°C .



Please be aware that an important notice concerning availability, standard warranty, and use in critical applications of Texas Instruments semiconductor products and disclaimers thereto appears at the end of this data sheet.

TL4051 PRECISION MICROPOWER SHUNT VOLTAGE REFERENCE

SLOS487–JUNE 2007

ORDERING INFORMATION⁽¹⁾

T _A	DEVICE GRADE	V _Z	PACKAGE ⁽²⁾		ORDERABLE PART NUMBER	TOP-SIDE MARKING ⁽³⁾
–40°C to 85°C	A grade: 0.1% initial accuracy and 50 ppm/°C temperature coefficient	ADJ	SOT-23-3 – DBZ	Reel of 3000	TL4051AIDBZR	TN2_
				Reel of 250	TL4051AIDBZT	
			SC-70 – DCK	Reel of 3000	TL4051AIDCKR	97_
				Reel of 250	TL4051AIDCKT	
		1.2 V	SOT-23-3 – DBZ	Reel of 3000	TL4051A12IDBZR	TN8_
				Reel of 250	TL4051A12IDBZT	
			SC-70 – DCK	Reel of 3000	TL4051A12IDCKR	9D_
				Reel of 250	TL4051A12IDCKT	
	B grade: 0.2% initial accuracy and 50 ppm/°C temperature coefficient	ADJ	SOT-23-3 – DBZ	Reel of 3000	TL4051BIDBZR	TN3_
				Reel of 250	TL4051BIDBZT	
			SC-70 – DCK	Reel of 3000	TL4051BIDCKR	98_
				Reel of 250	TL4051BIDCKT	
		1.2 V	SOT-23-3 – DBZ	Reel of 3000	TL4051B12IDBZR	TN9_
				Reel of 250	TL4051B12IDBZT	
			SC-70 – DCK	Reel of 3000	TL4051B12IDCKR	9E_
				Reel of 250	TL4051B12IDCKT	
	C grade: 0.5% initial accuracy and 50 ppm/°C temperature coefficient	ADJ	SOT-23-3 – DBZ	Reel of 3000	TL4051CIDBZR	TN4_
				Reel of 250	TL4051CIDBZT	
			SC-70 – DCK	Reel of 3000	TL4051CIDCKR	99_
				Reel of 250	TL4051CIDCKT	
		1.2 V	SOT-23-3 – DBZ	Reel of 3000	TL4051C12IDBZR	TNU_
				Reel of 250	TL4051C12IDBZT	
			SC-70 – DCK	Reel of 3000	TL4051C12IDCKR	9F_
				Reel of 250	TL4051C12IDCKT	

- (1) For the most current package and ordering information, see the Package Option Addendum at the end of this document, or see the TI web site at www.ti.com.
- (2) Package drawings, standard packing quantities, thermal data, symbolization, and PCB design guidelines are available at www.ti.com/sc/package.
- (3) The actual top-side marking has one additional character that designates the assembly/test site.

ORDERING INFORMATION⁽¹⁾

T _A	DEVICE GRADE	V _Z	PACKAGE ⁽²⁾		ORDERABLE PART NUMBER	TOP-SIDE MARKING ⁽³⁾
–40°C to 125°C	A grade: 0.1% initial accuracy and 50 ppm/°C temperature coefficient	ADJ	SOT-23-3 – DBZ	Reel of 3000	TL4051AQDBZR	TN5_
				Reel of 250	TL4051AQDBZT	
			SC-70 – DCK	Reel of 3000	TL4051AQDCKR	9A_
				Reel of 250	TL4051AQDCKT	
		1.2 V	SOT-23-3 – DBZ	Reel of 3000	TL4051A12QDBZR	TNV_
				Reel of 250	TL4051A12QDBZT	
			SC-70 – DCK	Reel of 3000	TL4051A12QDCKR	9G_
				Reel of 250	TL4051A12QDCKT	
	B grade: 0.2% initial accuracy and 50 ppm/°C temperature coefficient	ADJ	SOT-23-3 – DBZ	Reel of 3000	TL4051BQDBZR	TN6_
				Reel of 250	TL4051BQDBZT	
			SC-70 – DCK	Reel of 3000	TL4051BQDCKR	9B_
				Reel of 250	TL4051BQDCKT	
		1.2 V	SOT-23-3 – DBZ	Reel of 3000	TL4051B12QDBZR	TNW_
				Reel of 250	TL4051B12QDBZT	
			SC-70 – DCK	Reel of 3000	TL4051B12QDCKR	9H_
				Reel of 250	TL4051B12QDCKT	
	C grade: 0.5% initial accuracy and 50 ppm/°C temperature coefficient	ADJ	SOT-23-3 – DBZ	Reel of 3000	TL4051CQDBZR	TN7_
				Reel of 250	TL4051CQDBZT	
			SC-70 – DCK	Reel of 3000	TL4051CQDCKR	9C_
				Reel of 250	TL4051CQDCKT	
		1.2 V	SOT-23-3 – DBZ	Reel of 3000	TL4051C12QDBZR	TNY_
				Reel of 250	TL4051C12QDBZT	
			SC-70 – DCK	Reel of 3000	TL4051C12QDCKR	9J_
				Reel of 250	TL4051C12QDCKT	

- (1) For the most current package and ordering information, see the Package Option Addendum at the end of this document, or see the TI web site at www.ti.com.
- (2) Package drawings, standard packing quantities, thermal data, symbolization, and PCB design guidelines are available at www.ti.com/sc/package.
- (3) The actual top-side marking has one additional character that designates the assembly/test site.

FUNCTIONAL BLOCK DIAGRAM

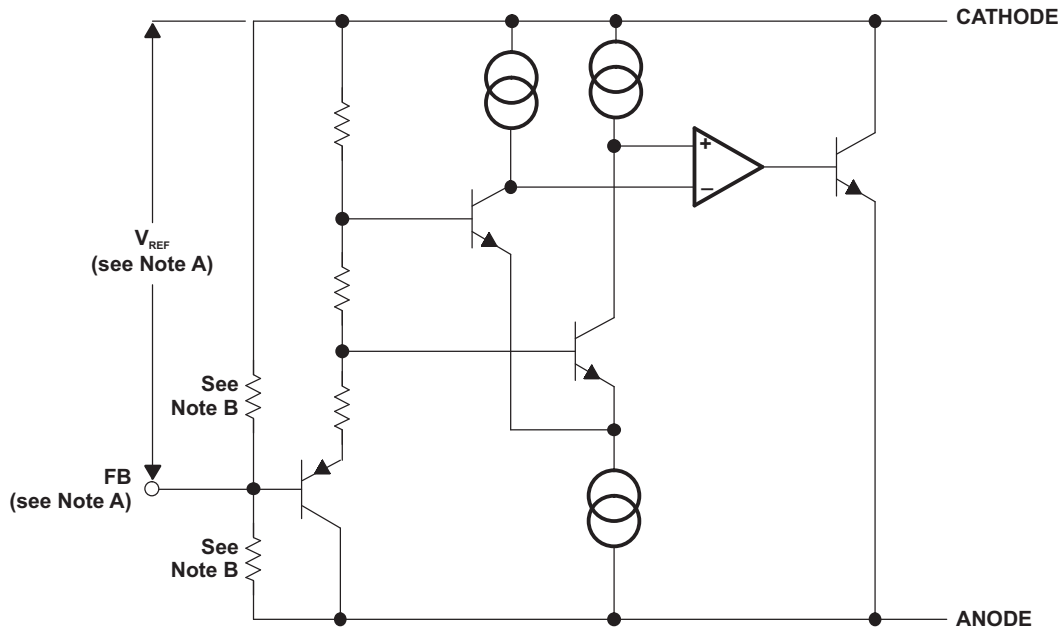

- A. TL4051x (Adjustable) only
- B. TL4051x12 only

Absolute Maximum Ratings⁽¹⁾

over free-air temperature range (unless otherwise noted)

		MIN	MAX	UNIT
V_Z	Continuous cathode voltage		15	V
I_Z	Continuous cathode current	-10	20	mA
θ_{JA}	Package thermal impedance ⁽²⁾⁽³⁾		206	°C/W
			252	
T_J	Operating virtual junction temperature		150	°C
T_{stg}	Storage temperature range	-65	150	°C

- (1) Stresses beyond those listed under *Absolute Maximum Ratings* may cause permanent damage to the device. These are stress ratings only, and functional operation of the device at these or any other conditions beyond those indicated under *Recommended Operating Conditions* is not implied. Exposure to absolute-maximum-rated conditions for extended periods may affect device reliability.
- (2) Maximum power dissipation is a function of $T_J(\text{max})$, θ_{JA} , and T_A . The maximum allowable power dissipation at any allowable ambient temperature is $P_D = (T_J(\text{max}) - T_A)/\theta_{JA}$. Operating at the absolute maximum T_J of 150°C can affect reliability.
- (3) The package thermal impedance is calculated in accordance with JESD 51-7.

Recommended Operating Conditions

		MIN	MAX	UNIT	
I_Z	Cathode current	⁽¹⁾	12	mA	
V_Z	Reverse breakdown voltage (adjustable version)		10	V	
T_A	Free-air temperature	I temperature	-40	85	°C
		Q temperature	-40	125	

- (1) See parametric tables

TL4051x12I Electrical Characteristics

full range $T_A = -40^\circ\text{C}$ to 85°C (unless otherwise noted)

PARAMETER	TEST CONDITIONS	T_A	TL4051A12I			TL4051B12I			TL4051C12I			UNIT
			MIN	TYP	MAX	MIN	TYP	MAX	MIN	TYP	MAX	
V_Z Reverse breakdown voltage	$I_Z = 100\ \mu\text{A}$	25°C	1.225			1.225			1.225			V
		Reverse breakdown voltage tolerance	25°C	-1.2	1.2	-2.4	2.4	-6	6			mV
$I_{Z,\text{min}}$ Minimum cathode current		25°C	39	60	39	60	39	60			μA	
		Full range	65		65		65					
α_{V_Z} Average temperature coefficient of reverse breakdown voltage	$I_Z = 10\ \text{mA}$	25°C	± 20			± 20			± 20			ppm/°C
	$I_Z = 1\ \text{mA}$	25°C	± 15			± 15			± 15			
	$I_Z = 100\ \mu\text{A}$	25°C	± 15			± 15			± 15			
		Full range	± 50			± 50			± 50			
$\frac{\Delta V_Z}{\Delta I_Z}$ Reverse breakdown voltage change with cathode current change	$I_{Z,\text{min}} < I_Z < 1\ \text{mA}$	25°C	0.3	1.1	0.3	1.1	0.3	1.1			mV	
		Full range	1.5		1.5		1.5					
	$1\ \text{mA} < I_Z < 12\ \text{mA}$	25°C	1.8	6	1.8	6	1.8	6				
		Full range	8		8		8					
Z_Z Reverse dynamic impedance	$I_Z = 1\ \text{mA}$, $f = 120\ \text{Hz}$, $I_{AC} = 0.1 I_Z$	25°C	0.5			0.5			0.5			Ω
e_N Wideband noise	$I_Z = 100\ \mu\text{A}$, $10\ \text{Hz} \leq f \leq 10\ \text{kHz}$	25°C	20			20			20			μV_{RMS}
Long-term stability of reverse breakdown voltage	$t = 1000\ \text{h}$, $T_A = 25^\circ\text{C} \pm 0.1^\circ\text{C}$, $I_Z = 100\ \mu\text{A}$	25°C	120			120			120			ppm
V_{HYST} Thermal hysteresis ⁽¹⁾	$\Delta T_A = -40^\circ\text{C}$ to 125°C		0.36			0.36			0.36			mV/V

(1) Thermal hysteresis is defined as $V_{Z,25^\circ\text{C}}$ (after cycling to -40°C) – $V_{Z,25^\circ\text{C}}$ (after cycling to 125°C).

TL4051 PRECISION MICROPOWER SHUNT VOLTAGE REFERENCE

SLOS487–JUNE 2007

TL4051x12Q Electrical Characteristics

full range $T_A = -40^\circ\text{C}$ to 125°C (unless otherwise noted)

PARAMETER	TEST CONDITIONS	T_A	TL4051A12Q			TL4051B12Q			TL4051C12Q			UNIT
			MIN	TYP	MAX	MIN	TYP	MAX	MIN	TYP	MAX	
V_Z Reverse breakdown voltage	$I_Z = 100\ \mu\text{A}$	25°C	1.225			1.225			1.225			V
		Reverse breakdown voltage tolerance	25°C	-1.2	1.2	-2.4	2.4	-6	6			mV
$I_{Z,\text{min}}$ Minimum cathode current		25°C	39	60	39	60	39	60			μA	
		Full range	65		65		65					
α_{V_Z} Average temperature coefficient of reverse breakdown voltage	$I_Z = 10\ \text{mA}$	25°C	± 20			± 20			± 20			ppm/°C
	$I_Z = 1\ \text{mA}$	25°C	± 15			± 15			± 15			
	$I_Z = 100\ \mu\text{A}$	25°C	± 15			± 15			± 15			
		Full range	± 50			± 50			± 50			
$\frac{\Delta V_Z}{\Delta I_Z}$ Reverse breakdown voltage change with cathode current change	$I_{Z,\text{min}} < I_Z < 1\ \text{mA}$	25°C	0.3	1.1	0.3	1.1	0.3	1.1			mV	
		Full range	1.5		1.5		1.5					
	$1\ \text{mA} < I_Z < 12\ \text{mA}$	25°C	1.8	6	1.8	6	1.8	6				
		Full range	8		8		8					
Z_Z Reverse dynamic impedance	$I_Z = 1\ \text{mA}$, $f = 120\ \text{Hz}$, $I_{AC} = 0.1 I_Z$	25°C	0.5			0.5			0.5			Ω
e_N Wideband noise	$I_Z = 100\ \mu\text{A}$, $10\ \text{Hz} \leq f \leq 10\ \text{kHz}$	25°C	20			20			20			μV_{RMS}
Long-term stability of reverse breakdown voltage	$t = 1000\ \text{h}$, $T_A = 25^\circ\text{C} \pm 0.1^\circ\text{C}$, $I_Z = 100\ \mu\text{A}$	25°C	120			120			120			ppm
V_{HYST} Thermal hysteresis ⁽¹⁾	$\Delta T_A = -40^\circ\text{C}$ to 125°C		0.36			0.36			0.36			mV/V

(1) Thermal hysteresis is defined as $V_{Z,25^\circ\text{C}}$ (after cycling to -40°C) – $V_{Z,25^\circ\text{C}}$ (after cycling to 125°C).

TL4051xl (Adjustable Version) Electrical Characteristics

full range $T_A = -40^\circ\text{C}$ to 85°C (unless otherwise noted)

PARAMETER	TEST CONDITIONS	T_A	TL4051AI			TL4051BI			TL4051CI			UNIT
			MIN	TYP	MAX	MIN	TYP	MAX	MIN	TYP	MAX	
V_{REF} Reference voltage	$I_Z = 100\ \mu\text{A}$, $V_Z = 5\ \text{V}$	25°C	1.212			1.212			1.212			V
Reference voltage tolerance ⁽¹⁾	$I_Z = 100\ \mu\text{A}$, $V_Z = 5\ \text{V}$	25°C	-1.2	1.2		-2.4	2.4		-6	6		mV
		Full range	-5.2	5.2		-6.4	6.4		-10.1	10.1		
$I_{Z,min}$ Minimum cathode current		25°C	36		60		36		60		μA	
		Full range			65				70			
$\frac{\Delta V_{REF}}{\Delta I_Z}$ Reference voltage change with cathode current change	$I_{Z,min} < I_Z < 1\ \text{mA}$	25°C	0.3		1.1		0.3		1.1		mV	
		Full range			1.5				1.5			
	$1\ \text{mA} < I_Z < 12\ \text{mA}$	25°C	0.6		6		0.6		6			
		Full range			8				8			
$\frac{\Delta V_{REF}}{\Delta V_{KA}}$ Reference voltage change with output voltage change	$I_Z = 1\ \text{mA}$	25°C	-1.69	-2.8		-1.69	-2.8		-1.69	-2.8		mV/V
		Full range			-3.5				-3.5			
I_{FB} Feedback current		25°C	70		130		70		130		nA	
		Full range			150				150			
$\alpha_{V_{REF}}$ Average temperature coefficient of reference voltage ⁽¹⁾	$I_Z = 10\ \text{mA}$, $V_Z = 2.5\ \text{V}$	25°C	± 20			± 20			± 20			ppm/ $^\circ\text{C}$
	$I_Z = 1\ \text{mA}$, $V_Z = 2.5\ \text{V}$	25°C	± 15			± 15			± 15			
	$I_Z = 100\ \mu\text{A}$, $V_Z = 2.5\ \text{V}$	25°C	± 15			± 15			± 15			
		Full range				± 50			± 50			
Z_Z Reverse dynamic impedance	$I_Z = 1\ \text{mA}$, $f = 120\ \text{Hz}$, $I_{AC} = 0.1\ I_Z$, $V_Z = V_{REF}$	25°C	0.3			0.3			0.3			Ω
	$I_Z = 1\ \text{mA}$, $f = 120\ \text{Hz}$, $I_{AC} = 0.1\ I_Z$, $V_Z = 10\ \text{V}$	25°C	2			2			2			
e_N Wideband noise	$I_Z = 100\ \mu\text{A}$, $V_Z = V_{REF}$, $10\ \text{Hz} \leq f \leq 10\ \text{kHz}$	25°C	20			20			20			μV_{RMS}
Long-term stability of reverse breakdown voltage	$t = 1000\ \text{h}$, $T_A = 25^\circ\text{C} \pm 0.1^\circ\text{C}$, $I_Z = 100\ \mu\text{A}$	25°C	120			120			120			ppm
V_{HYST} Thermal hysteresis ⁽²⁾	$\Delta T_A = -40^\circ\text{C}$ to 125°C		0.3			0.3			0.3			mV/V

(1) Reference voltage tolerance and average temperature coefficient change with output voltage (V_Z). See *Typical Characteristics*.

(2) Thermal hysteresis is defined as $V_{Z,25^\circ\text{C}}$ (after cycling to -40°C) $- V_{Z,25^\circ\text{C}}$ (after cycling to 125°C).

TL4051 PRECISION MICROPOWER SHUNT VOLTAGE REFERENCE

SLOS487–JUNE 2007

TL4051xQ (Adjustable Version) Electrical Characteristics

full range $T_A = -40^\circ\text{C}$ to 125°C (unless otherwise noted)

PARAMETER	TEST CONDITIONS	T_A	TL4051AQ			TL4051BQ			TL4051CQ			UNIT
			MIN	TYP	MAX	MIN	TYP	MAX	MIN	TYP	MAX	
V_{REF} Reference voltage	$I_Z = 100\ \mu\text{A}$, $V_Z = 5\ \text{V}$	25°C	1.212			1.212			1.212			V
Reference voltage tolerance ⁽¹⁾	$I_Z = 100\ \mu\text{A}$, $V_Z = 5\ \text{V}$	25°C	-1.2	1.2		-2.4	2.4		-6	6		mV
		Full range	-7.4	7.4		-8.6	8.6		-12.2	12.2		
$I_{Z,min}$ Minimum cathode current		25°C	36		60		36		60		μA	
		Full range	70		70		70		75			
$\frac{\Delta V_{REF}}{\Delta I_Z}$ Reference voltage change with cathode current change	$I_{Z,min} < I_Z < 1\ \text{mA}$	25°C	0.3		1.1		0.3		1.1		mV	
		Full range	1.5		1.5		1.5		1.5			
	$1\ \text{mA} < I_Z < 12\ \text{mA}$	25°C	0.6		6		0.6		6			
		Full range	8		8		8		8			
$\frac{\Delta V_{REF}}{\Delta V_{KA}}$ Reference voltage change with output voltage change	$I_Z = 1\ \text{mA}$	25°C	-1.69	-2.8		-1.69	-2.8		-1.69	-2.8		mV/V
		Full range	-3.5		-3.5		-3.5		-3.5			
I_{FB} Feedback current		25°C	70		130		70		130		nA	
		Full range	150		150		150		150			
$\alpha_{V_{REF}}$ Average temperature coefficient of reference voltage ⁽¹⁾	$I_Z = 10\ \text{mA}$, $V_Z = 2.5\ \text{V}$	25°C	± 20			± 20			± 20			ppm/ $^\circ\text{C}$
	$I_Z = 1\ \text{mA}$, $V_Z = 2.5\ \text{V}$	25°C	± 15			± 15			± 15			
	$I_Z = 100\ \mu\text{A}$, $V_Z = 2.5\ \text{V}$	25°C	± 15			± 15			± 15			
		Full range	± 50			± 50			± 50			
Z_Z Reverse dynamic impedance	$I_Z = 1\ \text{mA}$, $f = 120\ \text{Hz}$, $I_{AC} = 0.1\ I_Z$, $V_Z = V_{REF}$	25°C	0.3			0.3			0.3			Ω
	$I_Z = 1\ \text{mA}$, $f = 120\ \text{Hz}$, $I_{AC} = 0.1\ I_Z$, $V_Z = 10\ \text{V}$	25°C	2			2			2			
e_N Wideband noise	$I_Z = 100\ \mu\text{A}$, $V_Z = V_{REF}$, $10\ \text{Hz} \leq f \leq 10\ \text{kHz}$	25°C	20			20			20			μV_{RMS}
Long-term stability of reverse breakdown voltage	$t = 1000\ \text{h}$, $T_A = 25^\circ\text{C} \pm 0.1^\circ\text{C}$, $I_Z = 100\ \mu\text{A}$	25°C	120			120			120			ppm
V_{HYST} Thermal hysteresis ⁽²⁾	$\Delta T_A = -40^\circ\text{C}$ to 125°C		0.3			0.3			0.3			mV/V

(1) Reference voltage tolerance and average temperature coefficient change with output voltage (V_Z). See *Typical Characteristics*.

(2) Thermal hysteresis is defined as $V_{Z,25^\circ\text{C}}$ (after cycling to -40°C) $- V_{Z,25^\circ\text{C}}$ (after cycling to 125°C).

TYPICAL CHARACTERISTICS

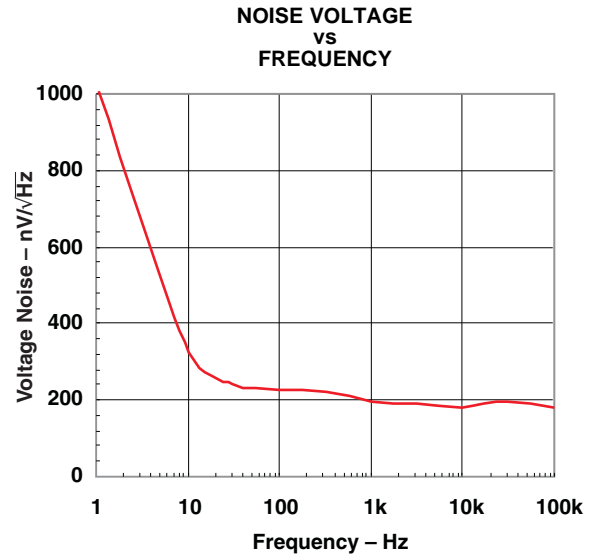
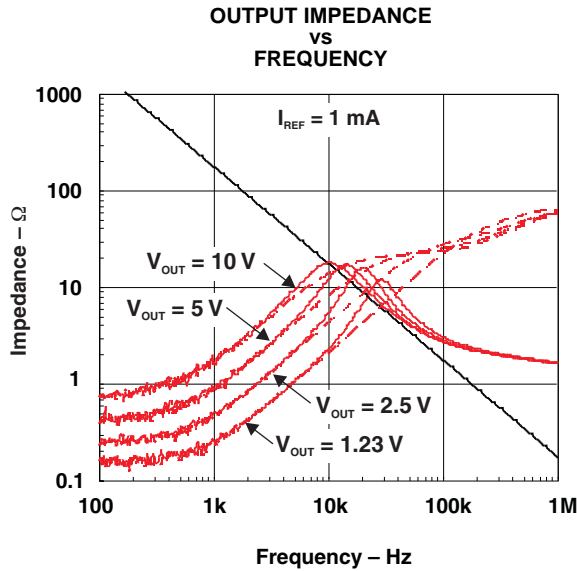
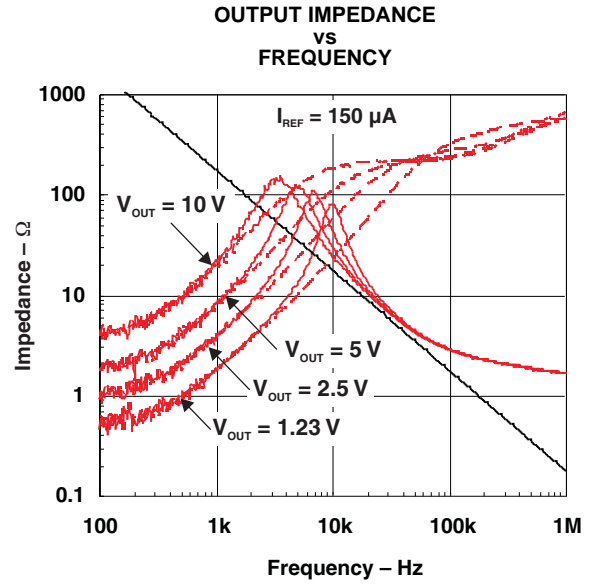
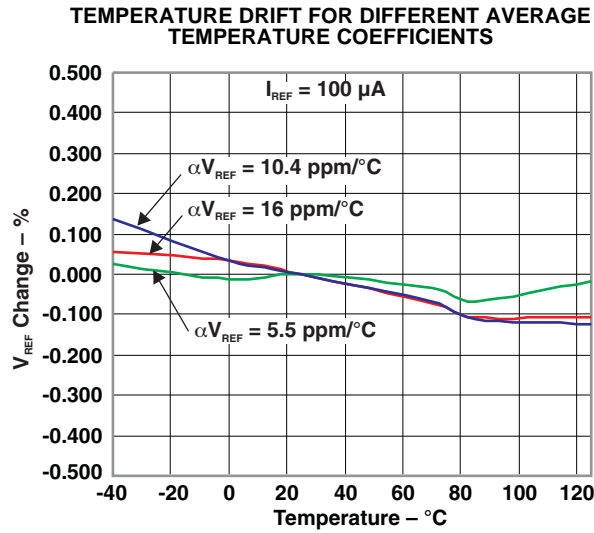

TYPICAL CHARACTERISTICS (continued)

REVERSE CHARACTERISTICS

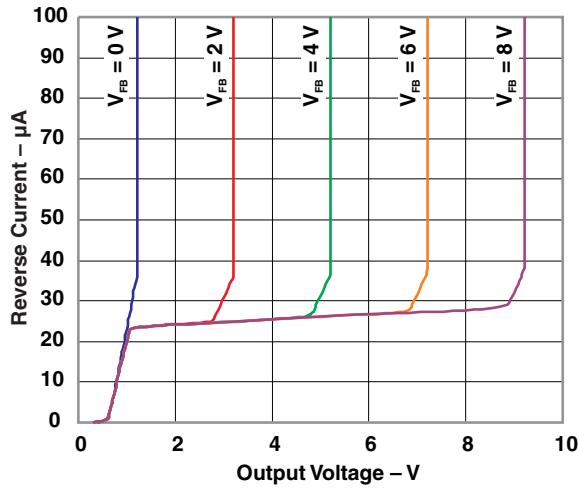

LARGE SIGNAL PULSE RESPONSE

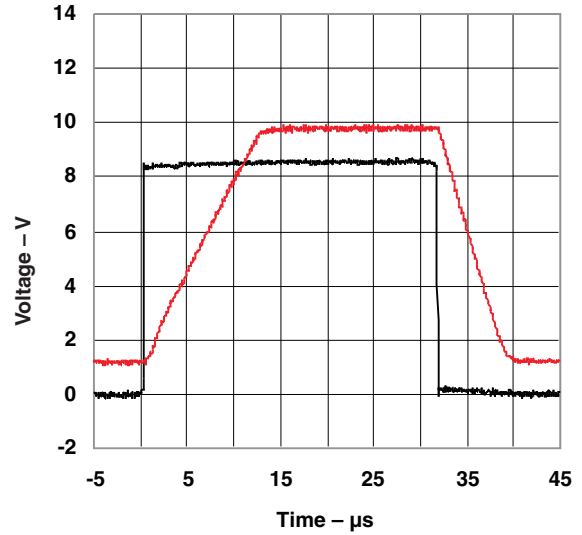

OUTPUT SATURATION
vs
OUTPUT CURRENT

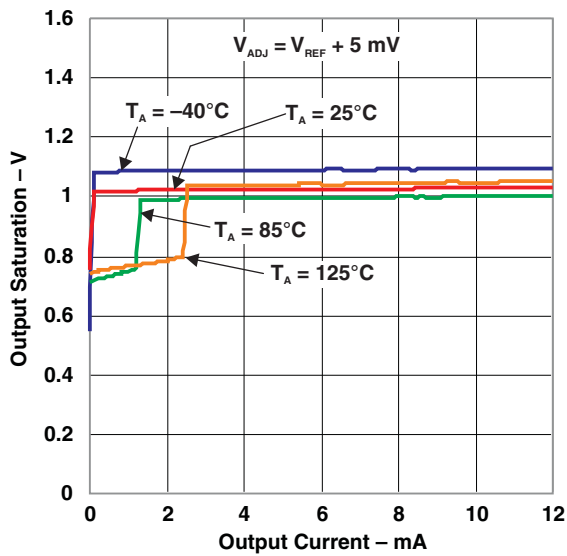

REVERSE CURRENT
vs
REVERSE VOLTAGE

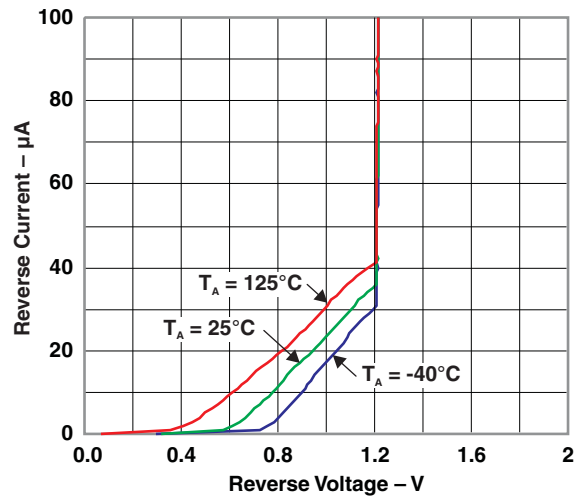

TYPICAL CHARACTERISTICS (continued)

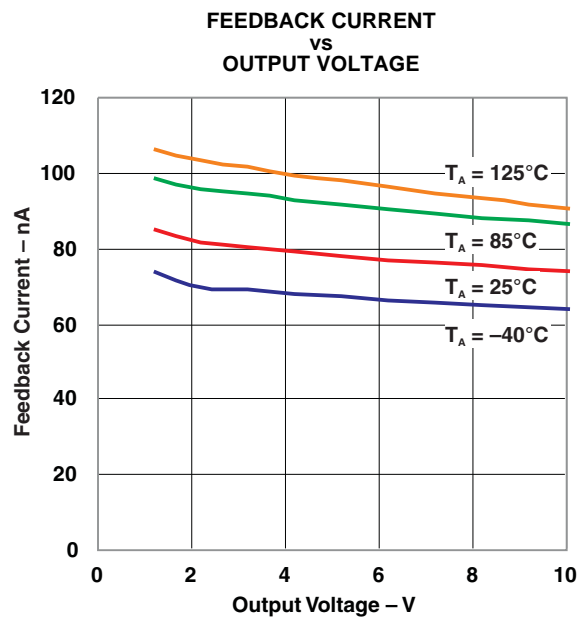
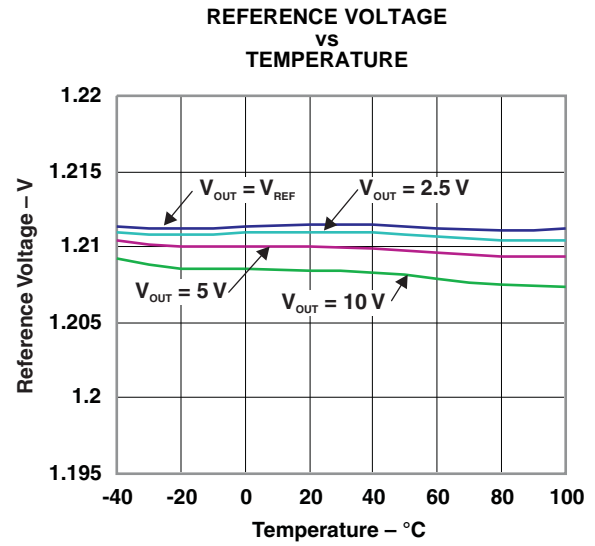
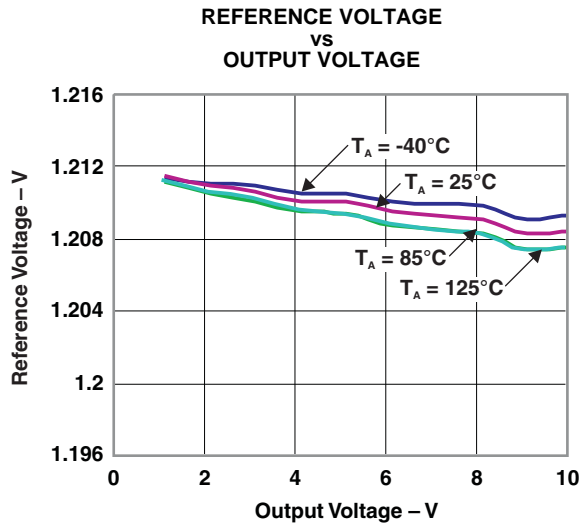

APPLICATION INFORMATION

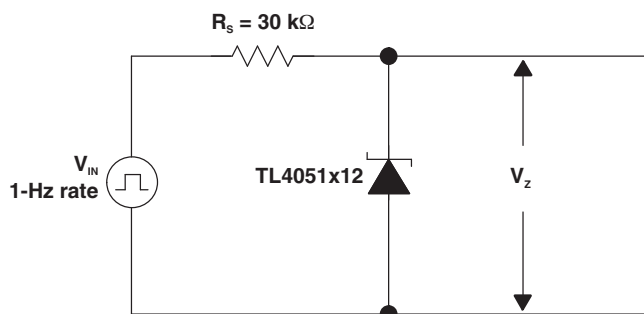

Figure 1. Start-Up Characteristics Test Circuit

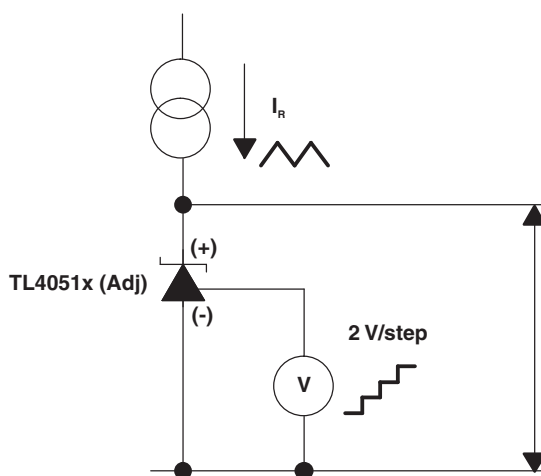

Figure 2. Reverse Characteristics Test Circuit

Output Capacitor

The TL4051 does not require an output capacitor across CATHODE and ANODE for stability. However, if an output bypass capacitor is desired, the TL4051 is designed to be stable with all capacitive loads.

SOT-23 Pin Connections

There is a parasitic Schottky diode connected between pins 2 and 3 of the SOT-23 packaged device. Thus, pin 3 of the SOT-23 package must be left floating or connected to pin 2.

APPLICATION INFORMATION (continued)

Adjustable Version

The adjustable version allows V_Z to be set by a user-defined resistor divider. The output voltage, V_Z , is set according to the equation shown in [Figure 3](#).

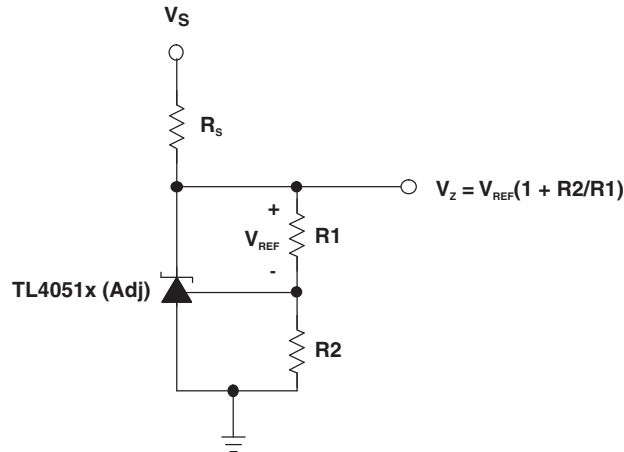

Figure 3. Adjustable Shunt Regulator

Cathode and Load Currents

In a typical shunt regulator configuration (see [Figure 4](#)), an external resistor, R_S , is connected between the supply and the cathode of the TL4051. R_S must be set properly, as it sets the total current available to supply the load (I_L) and bias the TL4051 (I_Z). In all cases, I_Z must stay within a specified range for proper operation of the reference. Taking into consideration one extreme in the variation of the load and supply voltage (maximum I_L and minimum V_S), R_S must be small enough to supply the minimum I_Z required for operation of the regulator, as given by data sheet parameters. At the other extreme, maximum V_S and minimum I_L , R_S must be large enough to limit I_Z to less than its maximum recommended rating of 12 mA.

R_S is calculated as shown in [Equation 1](#).

$$R_S = \frac{(V_S - V_Z)}{(I_L + I_Z)} \tag{1}$$

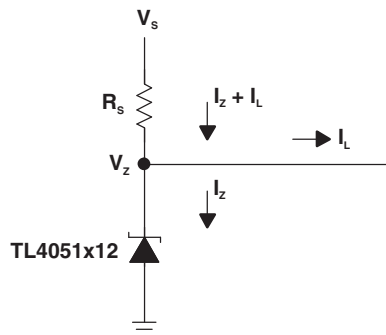

Figure 4. Shunt Regulator

PACKAGING INFORMATION

Orderable Device	Status (1)	Package Type	Package Drawing	Pins	Package Qty	Eco Plan (2)	Lead finish/ Ball material (6)	MSL Peak Temp (3)	Op Temp (°C)	Device Marking (4/5)	Samples
TL4051A12IDBZR	ACTIVE	SOT-23	DBZ	3	3000	RoHS & Green	NIPDAU	Level-1-260C-UNLIM	-40 to 85	TN8U	Samples
TL4051A12IDBZT	ACTIVE	SOT-23	DBZ	3	250	RoHS & Green	NIPDAU	Level-1-260C-UNLIM	-40 to 85	TN8U	Samples
TL4051A12QDBZR	ACTIVE	SOT-23	DBZ	3	3000	RoHS & Green	NIPDAU	Level-1-260C-UNLIM	-40 to 125	TNVU	Samples
TL4051A12QDBZT	ACTIVE	SOT-23	DBZ	3	250	RoHS & Green	NIPDAU	Level-1-260C-UNLIM	-40 to 125	TNVU	Samples
TL4051A12QDCKR	ACTIVE	SC70	DCK	5	3000	RoHS & Green	NIPDAU	Level-1-260C-UNLIM	-40 to 125	9GU	Samples
TL4051AIDBZR	ACTIVE	SOT-23	DBZ	3	3000	RoHS & Green	NIPDAU	Level-1-260C-UNLIM	-40 to 85	TN2U	Samples
TL4051AIDBZT	ACTIVE	SOT-23	DBZ	3	250	RoHS & Green	NIPDAU	Level-1-260C-UNLIM	-40 to 85	TN2U	Samples
TL4051AIDCKR	ACTIVE	SC70	DCK	5	3000	RoHS & Green	NIPDAU	Level-1-260C-UNLIM	-40 to 85	97U	Samples
TL4051AQDBZR	ACTIVE	SOT-23	DBZ	3	3000	RoHS & Green	NIPDAU	Level-1-260C-UNLIM	-40 to 125	TN5U	Samples
TL4051AQDCKR	ACTIVE	SC70	DCK	5	3000	RoHS & Green	NIPDAU	Level-1-260C-UNLIM	-40 to 125	9AU	Samples
TL4051B12IDBZR	ACTIVE	SOT-23	DBZ	3	3000	RoHS & Green	NIPDAU	Level-1-260C-UNLIM	-40 to 85	(TN93, TN9U)	Samples
TL4051B12IDBZT	ACTIVE	SOT-23	DBZ	3	250	RoHS & Green	NIPDAU	Level-1-260C-UNLIM	-40 to 85	(TN93, TN9U)	Samples
TL4051B12QDBZR	ACTIVE	SOT-23	DBZ	3	3000	RoHS & Green	NIPDAU	Level-1-260C-UNLIM	-40 to 125	(TNW3, TNWU)	Samples
TL4051B12QDCKR	ACTIVE	SC70	DCK	5	3000	RoHS & Green	NIPDAU	Level-1-260C-UNLIM	-40 to 125	9HU	Samples
TL4051BIDBZR	ACTIVE	SOT-23	DBZ	3	3000	RoHS & Green	NIPDAU	Level-1-260C-UNLIM	-40 to 85	TN3U	Samples
TL4051BIDBZT	ACTIVE	SOT-23	DBZ	3	250	RoHS & Green	NIPDAU	Level-1-260C-UNLIM	-40 to 85	TN3U	Samples
TL4051BIDCKR	ACTIVE	SC70	DCK	5	3000	RoHS & Green	NIPDAU	Level-1-260C-UNLIM	-40 to 85	98U	Samples
TL4051BQDBZR	ACTIVE	SOT-23	DBZ	3	3000	RoHS & Green	NIPDAU	Level-1-260C-UNLIM	-40 to 125	TN6U	Samples
TL4051BQDCKR	ACTIVE	SC70	DCK	5	3000	RoHS & Green	NIPDAU	Level-1-260C-UNLIM	-40 to 125	9BU	Samples
TL4051C12IDBZR	ACTIVE	SOT-23	DBZ	3	3000	RoHS & Green	NIPDAU	Level-1-260C-UNLIM	-40 to 85	TNUU	Samples

Orderable Device	Status (1)	Package Type	Package Drawing	Pins	Package Qty	Eco Plan (2)	Lead finish/ Ball material (6)	MSL Peak Temp (3)	Op Temp (°C)	Device Marking (4/5)	Samples
TL4051C12IDBZT	ACTIVE	SOT-23	DBZ	3	250	RoHS & Green	NIPDAU	Level-1-260C-UNLIM	-40 to 85	TNUU	Samples
TL4051C12IDCKR	ACTIVE	SC70	DCK	5	3000	RoHS & Green	NIPDAU	Level-1-260C-UNLIM	-40 to 85	9FU	Samples
TL4051C12QDBZR	ACTIVE	SOT-23	DBZ	3	3000	RoHS & Green	NIPDAU	Level-1-260C-UNLIM	-40 to 125	TNYU	Samples
TL4051C12QDBZT	ACTIVE	SOT-23	DBZ	3	250	RoHS & Green	NIPDAU	Level-1-260C-UNLIM	-40 to 125	TNYU	Samples
TL4051C12QDCKR	ACTIVE	SC70	DCK	5	3000	RoHS & Green	NIPDAU	Level-1-260C-UNLIM	-40 to 125	9JU	Samples
TL4051CIDBZR	ACTIVE	SOT-23	DBZ	3	3000	RoHS & Green	NIPDAU	Level-1-260C-UNLIM	-40 to 85	TN4U	Samples
TL4051CIDBZT	ACTIVE	SOT-23	DBZ	3	250	RoHS & Green	NIPDAU	Level-1-260C-UNLIM	-40 to 85	TN4U	Samples
TL4051CIDCKR	ACTIVE	SC70	DCK	5	3000	RoHS & Green	NIPDAU	Level-1-260C-UNLIM	-40 to 85	99U	Samples
TL4051CQDBZR	ACTIVE	SOT-23	DBZ	3	3000	RoHS & Green	NIPDAU	Level-1-260C-UNLIM	-40 to 125	TN7U	Samples
TL4051CQDCKR	ACTIVE	SC70	DCK	5	3000	RoHS & Green	NIPDAU	Level-1-260C-UNLIM	-40 to 125	9CU	Samples

(1) The marketing status values are defined as follows:

ACTIVE: Product device recommended for new designs.

LIFEBUY: TI has announced that the device will be discontinued, and a lifetime-buy period is in effect.

NRND: Not recommended for new designs. Device is in production to support existing customers, but TI does not recommend using this part in a new design.

PREVIEW: Device has been announced but is not in production. Samples may or may not be available.

OBSELETE: TI has discontinued the production of the device.

(2) **RoHS:** TI defines "RoHS" to mean semiconductor products that are compliant with the current EU RoHS requirements for all 10 RoHS substances, including the requirement that RoHS substance do not exceed 0.1% by weight in homogeneous materials. Where designed to be soldered at high temperatures, "RoHS" products are suitable for use in specified lead-free processes. TI may reference these types of products as "Pb-Free".

RoHS Exempt: TI defines "RoHS Exempt" to mean products that contain lead but are compliant with EU RoHS pursuant to a specific EU RoHS exemption.

Green: TI defines "Green" to mean the content of Chlorine (Cl) and Bromine (Br) based flame retardants meet JS709B low halogen requirements of <=1000ppm threshold. Antimony trioxide based flame retardants must also meet the <=1000ppm threshold requirement.

(3) MSL, Peak Temp. - The Moisture Sensitivity Level rating according to the JEDEC industry standard classifications, and peak solder temperature.

(4) There may be additional marking, which relates to the logo, the lot trace code information, or the environmental category on the device.

⁽⁵⁾ Multiple Device Markings will be inside parentheses. Only one Device Marking contained in parentheses and separated by a "~" will appear on a device. If a line is indented then it is a continuation of the previous line and the two combined represent the entire Device Marking for that device.

⁽⁶⁾ Lead finish/Ball material - Orderable Devices may have multiple material finish options. Finish options are separated by a vertical ruled line. Lead finish/Ball material values may wrap to two lines if the finish value exceeds the maximum column width.

Important Information and Disclaimer:The information provided on this page represents TI's knowledge and belief as of the date that it is provided. TI bases its knowledge and belief on information provided by third parties, and makes no representation or warranty as to the accuracy of such information. Efforts are underway to better integrate information from third parties. TI has taken and continues to take reasonable steps to provide representative and accurate information but may not have conducted destructive testing or chemical analysis on incoming materials and chemicals. TI and TI suppliers consider certain information to be proprietary, and thus CAS numbers and other limited information may not be available for release.

In no event shall TI's liability arising out of such information exceed the total purchase price of the TI part(s) at issue in this document sold by TI to Customer on an annual basis.

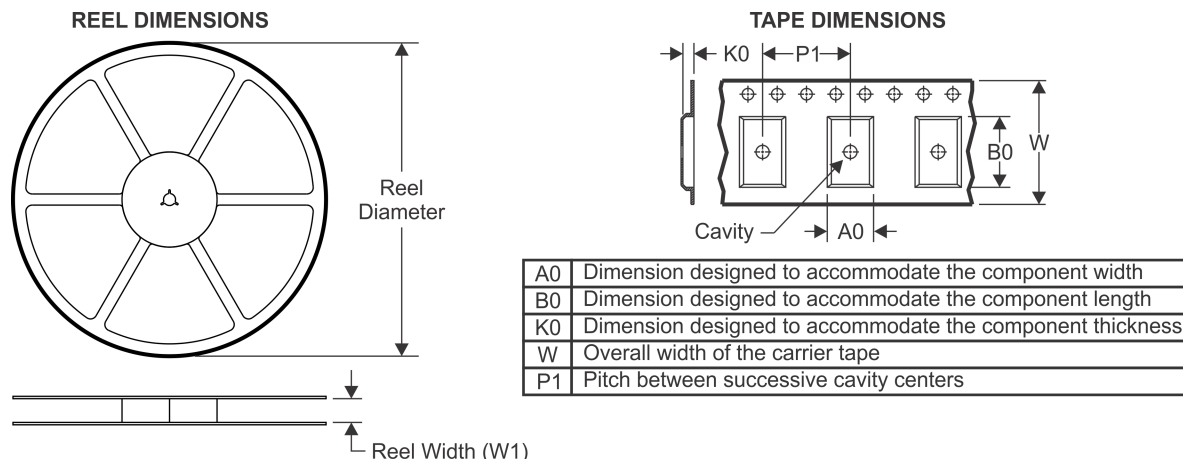
TAPE AND REEL INFORMATION

QUADRANT ASSIGNMENTS FOR PIN 1 ORIENTATION IN TAPE

*All dimensions are nominal

Device	Package Type	Package Drawing	Pins	SPQ	Reel Diameter (mm)	Reel Width W1 (mm)	A0 (mm)	B0 (mm)	K0 (mm)	P1 (mm)	W (mm)	Pin1 Quadrant
TL4051A12IDBZR	SOT-23	DBZ	3	3000	179.0	8.4	3.15	2.95	1.22	4.0	8.0	Q3
TL4051A12IDBZT	SOT-23	DBZ	3	250	179.0	8.4	3.15	2.95	1.22	4.0	8.0	Q3
TL4051A12QDBZR	SOT-23	DBZ	3	3000	179.0	8.4	3.15	2.95	1.22	4.0	8.0	Q3
TL4051A12QDBZT	SOT-23	DBZ	3	250	179.0	8.4	3.15	2.95	1.22	4.0	8.0	Q3
TL4051A12QDCKR	SC70	DCK	5	3000	179.0	8.4	2.2	2.5	1.2	4.0	8.0	Q3
TL4051AIDBZR	SOT-23	DBZ	3	3000	179.0	8.4	3.15	2.95	1.22	4.0	8.0	Q3
TL4051AIDBZT	SOT-23	DBZ	3	250	179.0	8.4	3.15	2.95	1.22	4.0	8.0	Q3
TL4051AIDCKR	SC70	DCK	5	3000	179.0	8.4	2.2	2.5	1.2	4.0	8.0	Q3
TL4051AQDBZR	SOT-23	DBZ	3	3000	179.0	8.4	3.15	2.95	1.22	4.0	8.0	Q3
TL4051AQDCKR	SC70	DCK	5	3000	179.0	8.4	2.2	2.5	1.2	4.0	8.0	Q3
TL4051B12IDBZR	SOT-23	DBZ	3	3000	179.0	8.4	3.15	2.95	1.22	4.0	8.0	Q3
TL4051B12IDBZR	SOT-23	DBZ	3	3000	178.0	9.2	3.15	2.77	1.22	4.0	8.0	Q3
TL4051B12IDBZT	SOT-23	DBZ	3	250	179.0	8.4	3.15	2.95	1.22	4.0	8.0	Q3
TL4051B12IDBZT	SOT-23	DBZ	3	250	178.0	9.2	3.15	2.77	1.22	4.0	8.0	Q3
TL4051B12QDBZR	SOT-23	DBZ	3	3000	179.0	8.4	3.15	2.95	1.22	4.0	8.0	Q3
TL4051B12QDBZR	SOT-23	DBZ	3	3000	178.0	9.2	3.15	2.77	1.22	4.0	8.0	Q3
TL4051B12QDCKR	SC70	DCK	5	3000	179.0	8.4	2.2	2.5	1.2	4.0	8.0	Q3
TL4051BIDBZR	SOT-23	DBZ	3	3000	179.0	8.4	3.15	2.95	1.22	4.0	8.0	Q3

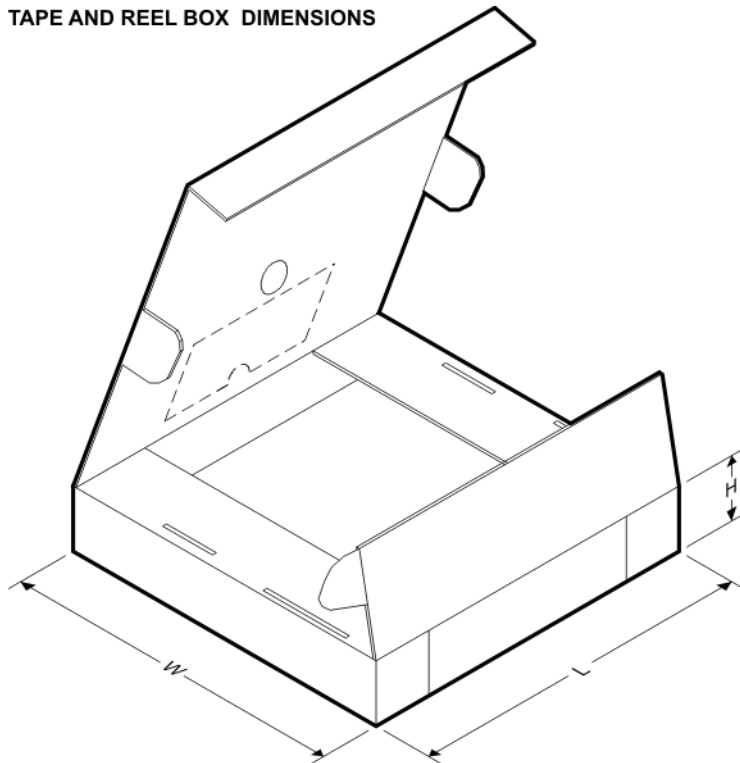
Device	Package Type	Package Drawing	Pins	SPQ	Reel Diameter (mm)	Reel Width W1 (mm)	A0 (mm)	B0 (mm)	K0 (mm)	P1 (mm)	W (mm)	Pin1 Quadrant
TL4051BIDBZT	SOT-23	DBZ	3	250	179.0	8.4	3.15	2.95	1.22	4.0	8.0	Q3
TL4051BIDCKR	SC70	DCK	5	3000	179.0	8.4	2.2	2.5	1.2	4.0	8.0	Q3
TL4051BQDBZR	SOT-23	DBZ	3	3000	179.0	8.4	3.15	2.95	1.22	4.0	8.0	Q3
TL4051BQDCKR	SC70	DCK	5	3000	179.0	8.4	2.2	2.5	1.2	4.0	8.0	Q3
TL4051C12IDBZR	SOT-23	DBZ	3	3000	179.0	8.4	3.15	2.95	1.22	4.0	8.0	Q3
TL4051C12IDBZT	SOT-23	DBZ	3	250	179.0	8.4	3.15	2.95	1.22	4.0	8.0	Q3
TL4051C12IDCKR	SC70	DCK	5	3000	179.0	8.4	2.2	2.5	1.2	4.0	8.0	Q3
TL4051C12QDBZR	SOT-23	DBZ	3	3000	179.0	8.4	3.15	2.95	1.22	4.0	8.0	Q3
TL4051C12QDBZT	SOT-23	DBZ	3	250	179.0	8.4	3.15	2.95	1.22	4.0	8.0	Q3
TL4051C12QDCKR	SC70	DCK	5	3000	179.0	8.4	2.2	2.5	1.2	4.0	8.0	Q3
TL4051CIDBZR	SOT-23	DBZ	3	3000	179.0	8.4	3.15	2.95	1.22	4.0	8.0	Q3
TL4051CIDBZT	SOT-23	DBZ	3	250	179.0	8.4	3.15	2.95	1.22	4.0	8.0	Q3
TL4051CIDCKR	SC70	DCK	5	3000	179.0	8.4	2.2	2.5	1.2	4.0	8.0	Q3
TL4051CQDBZR	SOT-23	DBZ	3	3000	179.0	8.4	3.15	2.95	1.22	4.0	8.0	Q3
TL4051CQDCKR	SC70	DCK	5	3000	179.0	8.4	2.2	2.5	1.2	4.0	8.0	Q3

TAPE AND REEL BOX DIMENSIONS

*All dimensions are nominal

Device	Package Type	Package Drawing	Pins	SPQ	Length (mm)	Width (mm)	Height (mm)
TL4051A12IDBZR	SOT-23	DBZ	3	3000	203.0	203.0	35.0
TL4051A12IDBZT	SOT-23	DBZ	3	250	200.0	183.0	25.0

Device	Package Type	Package Drawing	Pins	SPQ	Length (mm)	Width (mm)	Height (mm)
TL4051A12QDBZR	SOT-23	DBZ	3	3000	200.0	183.0	25.0
TL4051A12QDBZT	SOT-23	DBZ	3	250	203.0	203.0	35.0
TL4051A12QDCKR	SC70	DCK	5	3000	200.0	183.0	25.0
TL4051AIDBZR	SOT-23	DBZ	3	3000	200.0	183.0	25.0
TL4051AIDBZT	SOT-23	DBZ	3	250	203.0	203.0	35.0
TL4051AIDCKR	SC70	DCK	5	3000	203.0	203.0	35.0
TL4051AQDBZR	SOT-23	DBZ	3	3000	200.0	183.0	25.0
TL4051AQDCKR	SC70	DCK	5	3000	200.0	183.0	25.0
TL4051B12IDBZR	SOT-23	DBZ	3	3000	200.0	183.0	25.0
TL4051B12IDBZR	SOT-23	DBZ	3	3000	180.0	180.0	18.0
TL4051B12IDBZT	SOT-23	DBZ	3	250	203.0	203.0	35.0
TL4051B12IDBZT	SOT-23	DBZ	3	250	180.0	180.0	18.0
TL4051B12QDBZR	SOT-23	DBZ	3	3000	203.0	203.0	35.0
TL4051B12QDBZR	SOT-23	DBZ	3	3000	180.0	180.0	18.0
TL4051B12QDCKR	SC70	DCK	5	3000	203.0	203.0	35.0
TL4051BIDBZR	SOT-23	DBZ	3	3000	200.0	183.0	25.0
TL4051BIDBZT	SOT-23	DBZ	3	250	203.0	203.0	35.0
TL4051BIDCKR	SC70	DCK	5	3000	203.0	203.0	35.0
TL4051BQDBZR	SOT-23	DBZ	3	3000	203.0	203.0	35.0
TL4051BQDCKR	SC70	DCK	5	3000	200.0	183.0	25.0
TL4051C12IDBZR	SOT-23	DBZ	3	3000	200.0	183.0	25.0
TL4051C12IDBZT	SOT-23	DBZ	3	250	203.0	203.0	35.0
TL4051C12IDCKR	SC70	DCK	5	3000	200.0	183.0	25.0
TL4051C12QDBZR	SOT-23	DBZ	3	3000	200.0	183.0	25.0
TL4051C12QDBZT	SOT-23	DBZ	3	250	203.0	203.0	35.0
TL4051C12QDCKR	SC70	DCK	5	3000	200.0	183.0	25.0
TL4051CIDBZR	SOT-23	DBZ	3	3000	200.0	183.0	25.0
TL4051CIDBZT	SOT-23	DBZ	3	250	200.0	183.0	25.0
TL4051CIDCKR	SC70	DCK	5	3000	200.0	183.0	25.0
TL4051CQDBZR	SOT-23	DBZ	3	3000	200.0	183.0	25.0
TL4051CQDCKR	SC70	DCK	5	3000	203.0	203.0	35.0

DBZ0003A

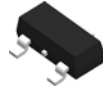

PACKAGE OUTLINE

SOT-23 - 1.12 mm max height

SMALL OUTLINE TRANSISTOR

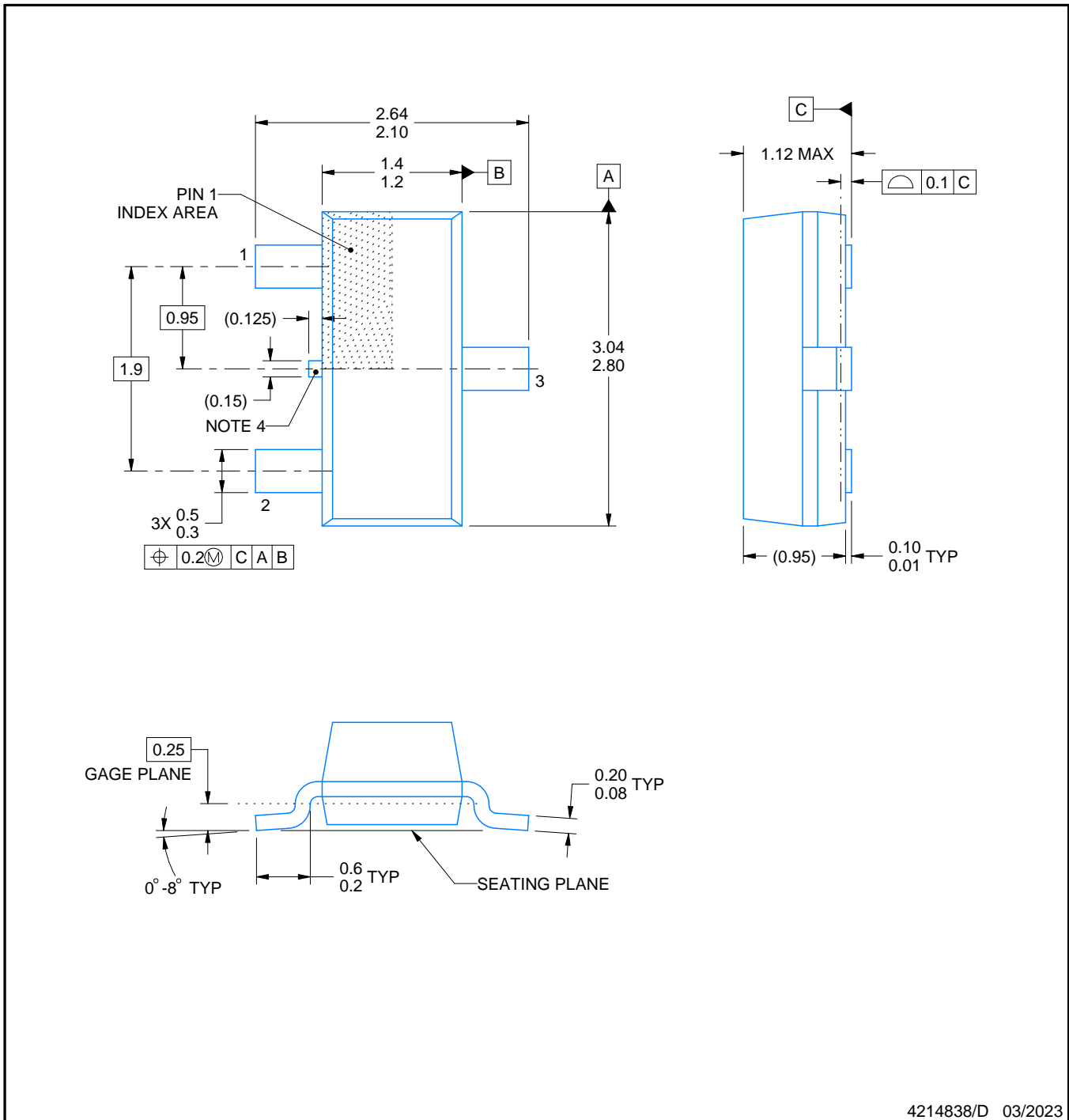

4214838/D 03/2023

NOTES:

1. All linear dimensions are in millimeters. Any dimensions in parenthesis are for reference only. Dimensioning and tolerancing per ASME Y14.5M.
2. This drawing is subject to change without notice.
3. Reference JEDEC registration TO-236, except minimum foot length.
4. Support pin may differ or may not be present.

EXAMPLE BOARD LAYOUT

DBZ0003A

SOT-23 - 1.12 mm max height

SMALL OUTLINE TRANSISTOR

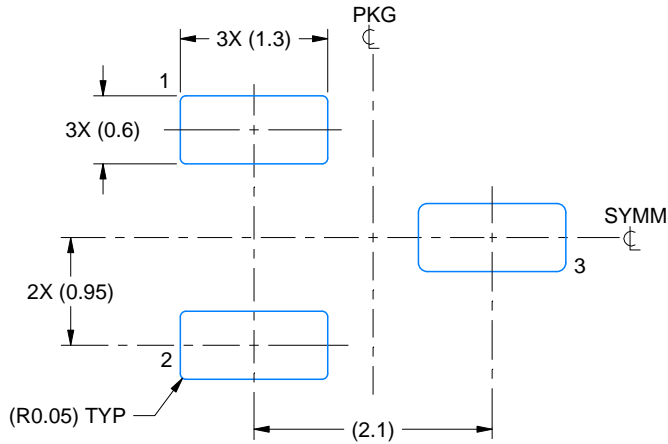

LAND PATTERN EXAMPLE
SCALE:15X

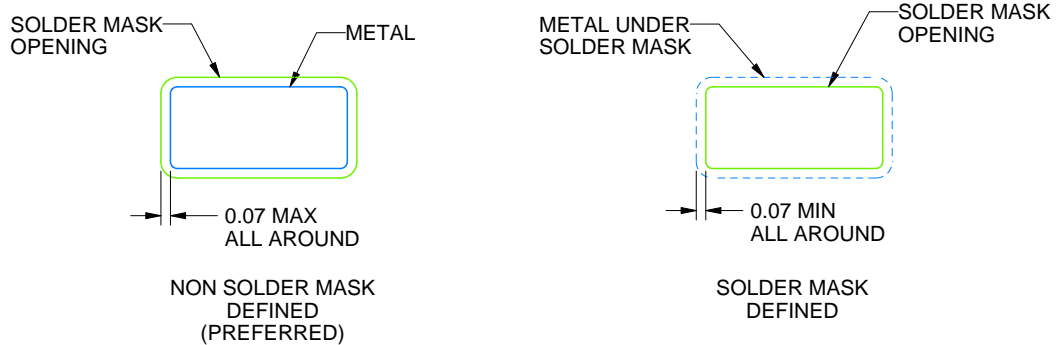

SOLDER MASK DETAILS

4214838/D 03/2023

NOTES: (continued)

- 4. Publication IPC-7351 may have alternate designs.
- 5. Solder mask tolerances between and around signal pads can vary based on board fabrication site.

EXAMPLE STENCIL DESIGN

DBZ0003A

SOT-23 - 1.12 mm max height

SMALL OUTLINE TRANSISTOR

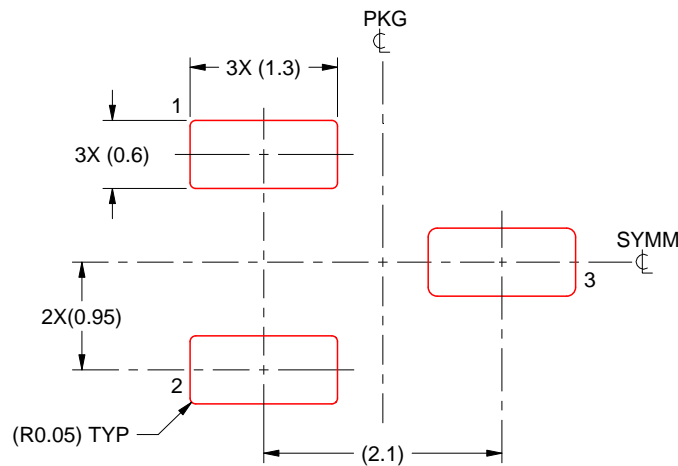

SOLDER PASTE EXAMPLE
BASED ON 0.125 THICK STENCIL
SCALE:15X

4214838/D 03/2023

NOTES: (continued)

6. Laser cutting apertures with trapezoidal walls and rounded corners may offer better paste release. IPC-7525 may have alternate design recommendations.
7. Board assembly site may have different recommendations for stencil design.



DCK0005A

PACKAGE OUTLINE

SOT - 1.1 max height

SMALL OUTLINE TRANSISTOR

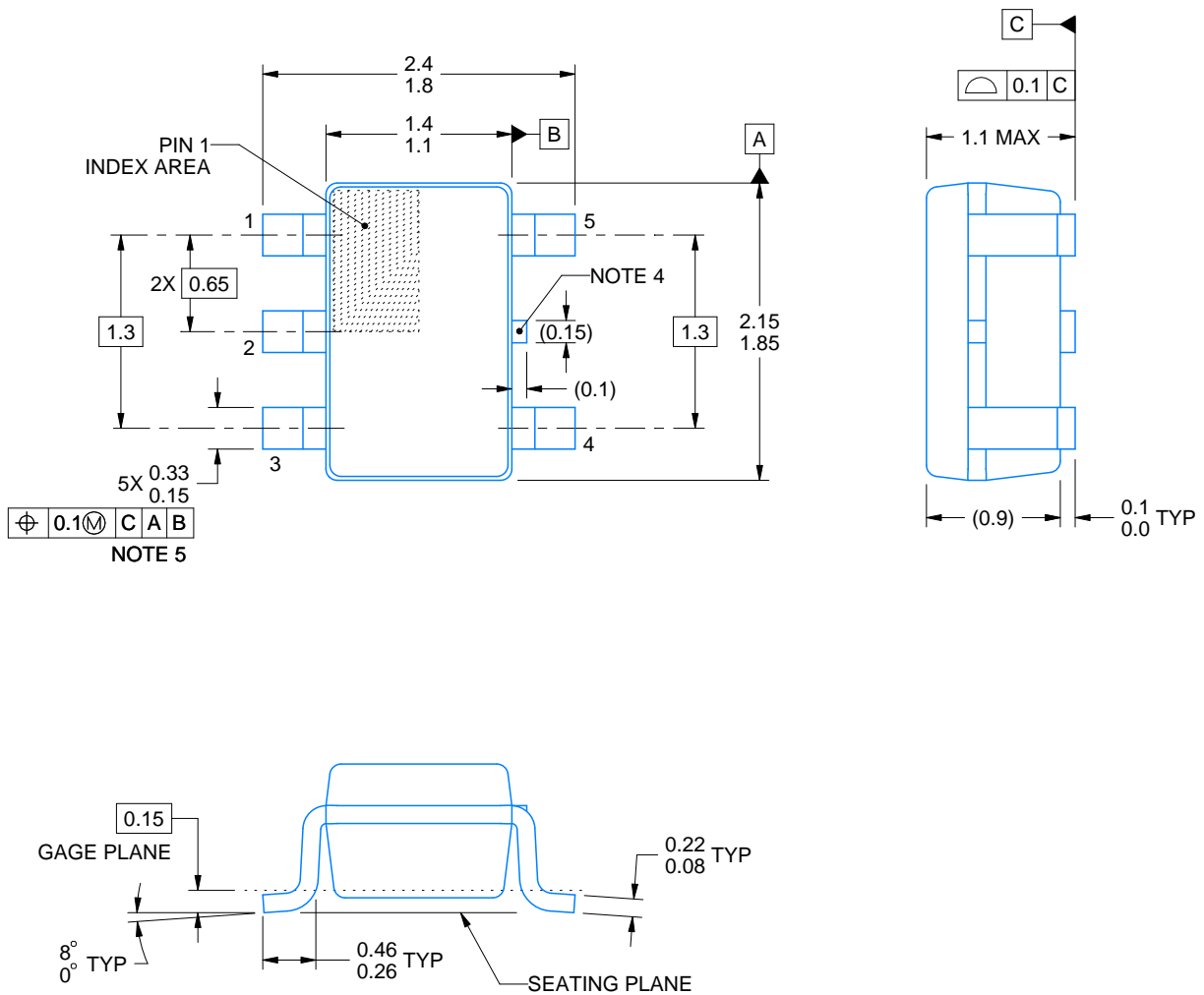

4214834/D 07/2023

NOTES:

1. All linear dimensions are in millimeters. Any dimensions in parenthesis are for reference only. Dimensioning and tolerancing per ASME Y14.5M.
2. This drawing is subject to change without notice.
3. Reference JEDEC MO-203.
4. Support pin may differ or may not be present.
5. Lead width does not comply with JEDEC.

EXAMPLE BOARD LAYOUT

DCK0005A

SOT - 1.1 max height

SMALL OUTLINE TRANSISTOR

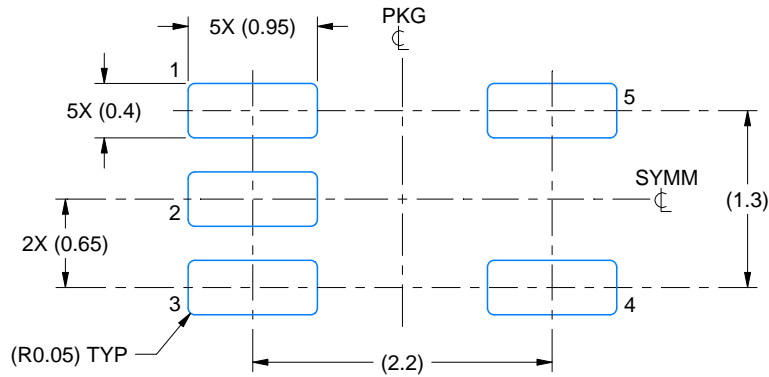

LAND PATTERN EXAMPLE
EXPOSED METAL SHOWN
SCALE:18X

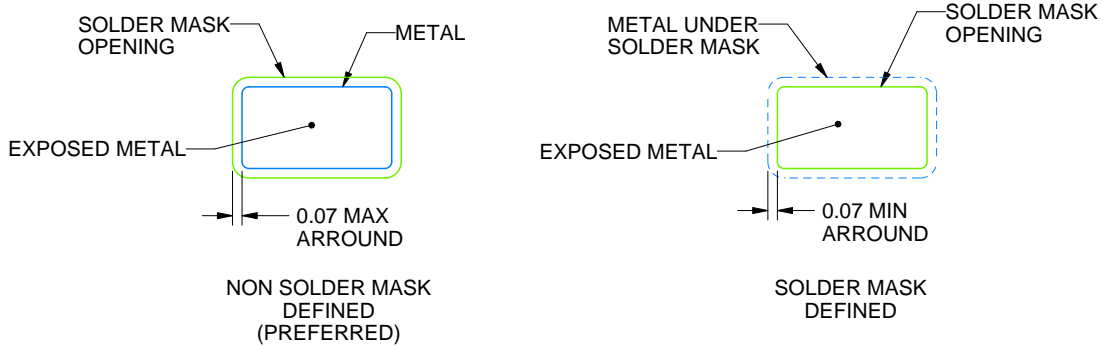

SOLDER MASK DETAILS

4214834/D 07/2023

NOTES: (continued)

- 6. Publication IPC-7351 may have alternate designs.
- 7. Solder mask tolerances between and around signal pads can vary based on board fabrication site.

EXAMPLE STENCIL DESIGN

DCK0005A

SOT - 1.1 max height

SMALL OUTLINE TRANSISTOR

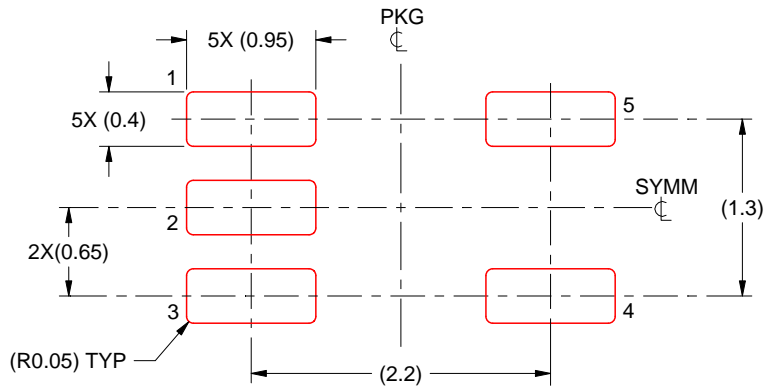

SOLDER PASTE EXAMPLE
BASED ON 0.125 THICK STENCIL
SCALE:18X

4214834/D 07/2023

NOTES: (continued)

8. Laser cutting apertures with trapezoidal walls and rounded corners may offer better paste release. IPC-7525 may have alternate design recommendations.
9. Board assembly site may have different recommendations for stencil design.

IMPORTANT NOTICE AND DISCLAIMER

TI PROVIDES TECHNICAL AND RELIABILITY DATA (INCLUDING DATA SHEETS), DESIGN RESOURCES (INCLUDING REFERENCE DESIGNS), APPLICATION OR OTHER DESIGN ADVICE, WEB TOOLS, SAFETY INFORMATION, AND OTHER RESOURCES "AS IS" AND WITH ALL FAULTS, AND DISCLAIMS ALL WARRANTIES, EXPRESS AND IMPLIED, INCLUDING WITHOUT LIMITATION ANY IMPLIED WARRANTIES OF MERCHANTABILITY, FITNESS FOR A PARTICULAR PURPOSE OR NON-INFRINGEMENT OF THIRD PARTY INTELLECTUAL PROPERTY RIGHTS.

These resources are intended for skilled developers designing with TI products. You are solely responsible for (1) selecting the appropriate TI products for your application, (2) designing, validating and testing your application, and (3) ensuring your application meets applicable standards, and any other safety, security, regulatory or other requirements.

These resources are subject to change without notice. TI grants you permission to use these resources only for development of an application that uses the TI products described in the resource. Other reproduction and display of these resources is prohibited. No license is granted to any other TI intellectual property right or to any third party intellectual property right. TI disclaims responsibility for, and you will fully indemnify TI and its representatives against, any claims, damages, costs, losses, and liabilities arising out of your use of these resources.

TI's products are provided subject to [TI's Terms of Sale](#) or other applicable terms available either on [ti.com](https://www.ti.com) or provided in conjunction with such TI products. TI's provision of these resources does not expand or otherwise alter TI's applicable warranties or warranty disclaimers for TI products.

TI objects to and rejects any additional or different terms you may have proposed.

Mailing Address: Texas Instruments, Post Office Box 655303, Dallas, Texas 75265
Copyright © 2024, Texas Instruments Incorporated

Looking for pricing, stock, or lifecycle information?

Click below to explore more details on WIN SOURCE:

 [View TL4051A12QDBZTG4 on WIN SOURCE](#)

 [Texas Instruments](#) Information

Optimize Your Supply Chain with WIN SOURCE Solutions

-  Global Sourcing Solution
-  Obsolete Management
-  Cost Control Management
-  Shortage Management
-  Alternative Solution
-  Excess Inventory Management