



THE DATASHEET OF TL431ACDG4



MSP-EXP430F5529 Experimenter's Board

User's Guide



Literature Number: SLAU330B
May 2011 – Revised April 2017

Preface	4
1 Getting Started	5
1.1 MSP-EXP430F5529 Experimenter's Board Introduction	5
1.2 Kit Contents	5
2 User Experience Software	6
2.1 Introduction	6
2.2 Main Menu	7
2.3 Clock	7
2.4 Games	7
2.5 Power Tests	7
2.6 Demo Apps	8
2.7 SD Card Access	9
2.8 Settings Menu	9
3 Software Installation and Debugging	10
3.1 Software	10
3.2 Download the Required Software	10
3.3 Working With the Example Software	10
4 MSP-EXP430F5529 Hardware	14
4.1 Hardware Overview	14
4.2 Jumper Settings and Power	15
4.3 eZ-FET Emulator	18
4.4 MSP-EXP430F5529 Hardware Components	18
5 Frequently Asked Questions, References, and Schematics	21
5.1 Frequently Asked Questions	21
5.2 References	21
5.3 Schematics and BOM	22
Revision History	35

List of Figures

1	MSP-EXP430F5529 Experimenter's Board	5
2	User Experience Navigation	6
3	Selecting a CCS Workspace.....	11
4	Opening Existing Project	11
5	Simple Hardware Overview	14
6	Hardware Block Details.....	15
7	Common Power Jumper Settings	15
8	Visual Power Schematic.....	17
9	MSP430 Current Measurement Connection	18
10	Schematics (1 of 8)	22
11	Schematics (2 of 8)	23
12	Schematics (3 of 8)	24
13	Schematics (4 of 8)	25
14	Schematics (5 of 8)	26
15	Schematics (6 of 8)	27
16	Schematics (7 of 8)	28
17	Schematics (8 of 8)	29

List of Tables

1	MSP-EXP430F5529 Jumper Settings and Functionality	16
2	Push Buttons, Potentiometer, and LED Connections	19
3	Pinning Mapping for Header J4	20
4	Pin Mapping for Header J5	20
5	Pin Mapping for Header J12	20
6	Bill of Materials (BOM).....	30

Read This First

The kit is preprogrammed with an out-of-box demo to immediately demonstrate the capabilities of the MSP430 MCU and experimenter's board. This document describes the hardware, its use, and the example software.

If You Need Assistance

The primary sources of information for MSP430™ microcontrollers (MCUs) are the data sheets and the family user's guides. The most up-to-date versions of these documents can be found at www.ti.com/msp430.

Information specific to the MSP-EXP430F5529 Experimenter's Board can be found at www.ti.com/usbexp.

Customer support for MSP430 MCUs and the MSP-EXP430F5529 Experimenter's Board is provided by the [TI Product Information Center \(PIC\)](#) and on the [TI E2E™ Community Forum](#).

Related Documentation from Texas Instruments

[MSP-EXP430F5529 Experimenter's Board User's Guide](#)

[MSP-EXP430F5529 Experimenter's Board User Experience Software](#)

[MSP-EXP430F5529 Experimenter's Board Quick Start Guide](#)

[MSP-EXP430F5529 Experimenter's Board PCB Design Files](#)

[MSP430F552x Code Examples](#)

Trademarks

MSP430, E2E are trademarks of Texas Instruments.
All other trademarks are the property of their respective owners.

MSP-EXP430F5529 Experimenter's Board

1 Getting Started

1.1 MSP-EXP430F5529 Experimenter's Board Introduction

The MSP-EXP430F5529 Experimenter's Board is a development platform based on the MSP430F5529 with integrated USB. The experimenter's board showcases the abilities of the latest family of MSP430 MCUs and is perfect for learning and developing USB-based applications using the MSP430 MCUs. The features include a 102x64 dot-matrix LCD, microSD memory card interface, 3-axis accelerometer, five capacitive-touch pads, RF EVM expansion headers, nine LEDs, an analog thumb wheel, easy access to spare F5529 pins, integrated Spy-Bi-Wire (SBW) flash emulation module, and standard full JTAG pin access.

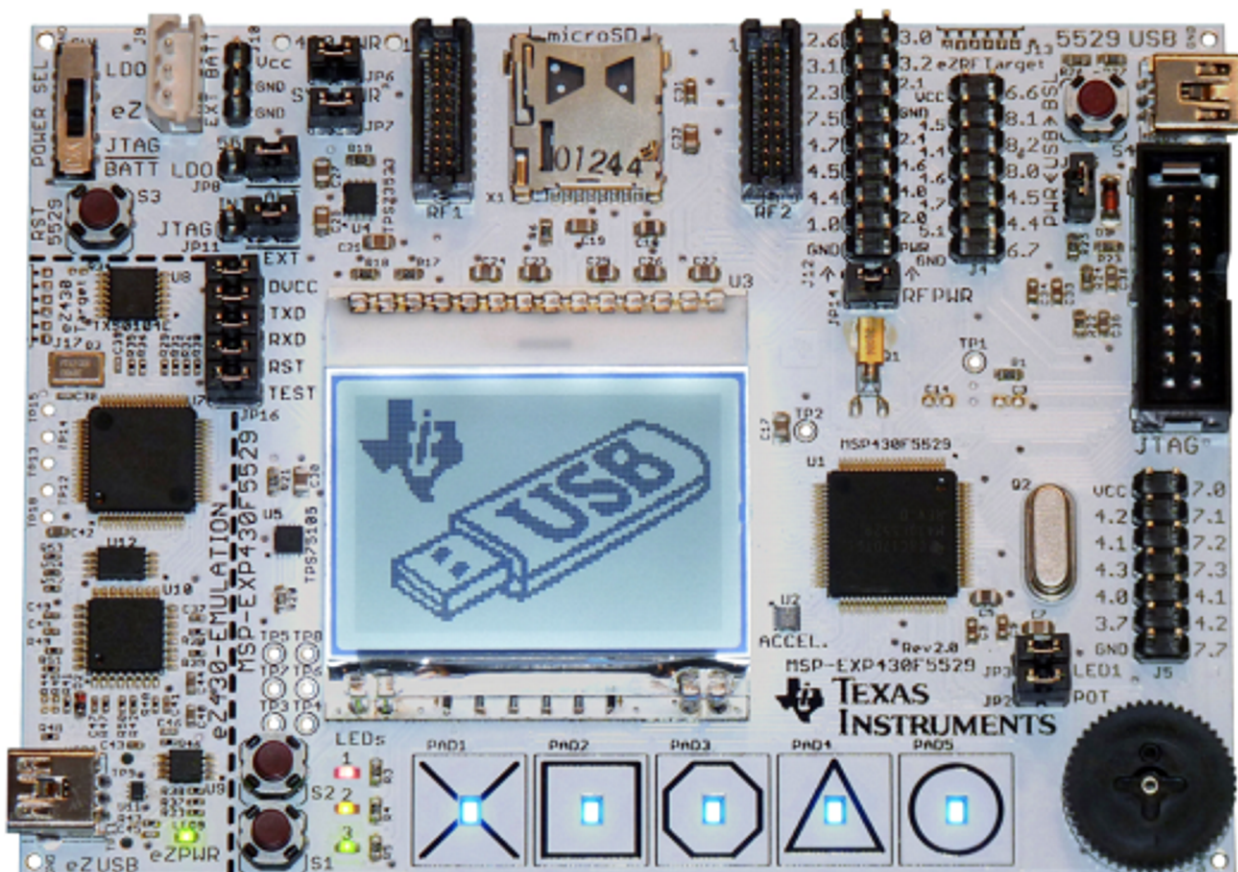

Figure 1. MSP-EXP430F5529 Experimenter's Board

The MSP-EXP430F5529 Experimenter's Board is available for purchase from the [TI Store](#).

1.2 Kit Contents

- MSP-EXP430F5529 Experimenter's Board

- Two mini-USB cables
- Battery holder
- 1GB microSD card
- Quick start guide

2 User Experience Software

2.1 Introduction

The MSP-EXP430F5529 Experimenter's Board arrives with a User Experience application installed to demonstrate a few of the capabilities of the MSP430F5529. Set the power switch to "LDO", and connect your PC to the "5529 USB" connection (see Figure 2). A splash screen displaying the TI logo should appear on the LCD. Wait approximately three seconds, or press the S1 or S2 button to display the Main Menu. Use the thumb wheel to navigate up and down the menu items on the LCD screen. Press the S1 pushbutton to enter a selection, or press the S2 pushbutton to cancel.

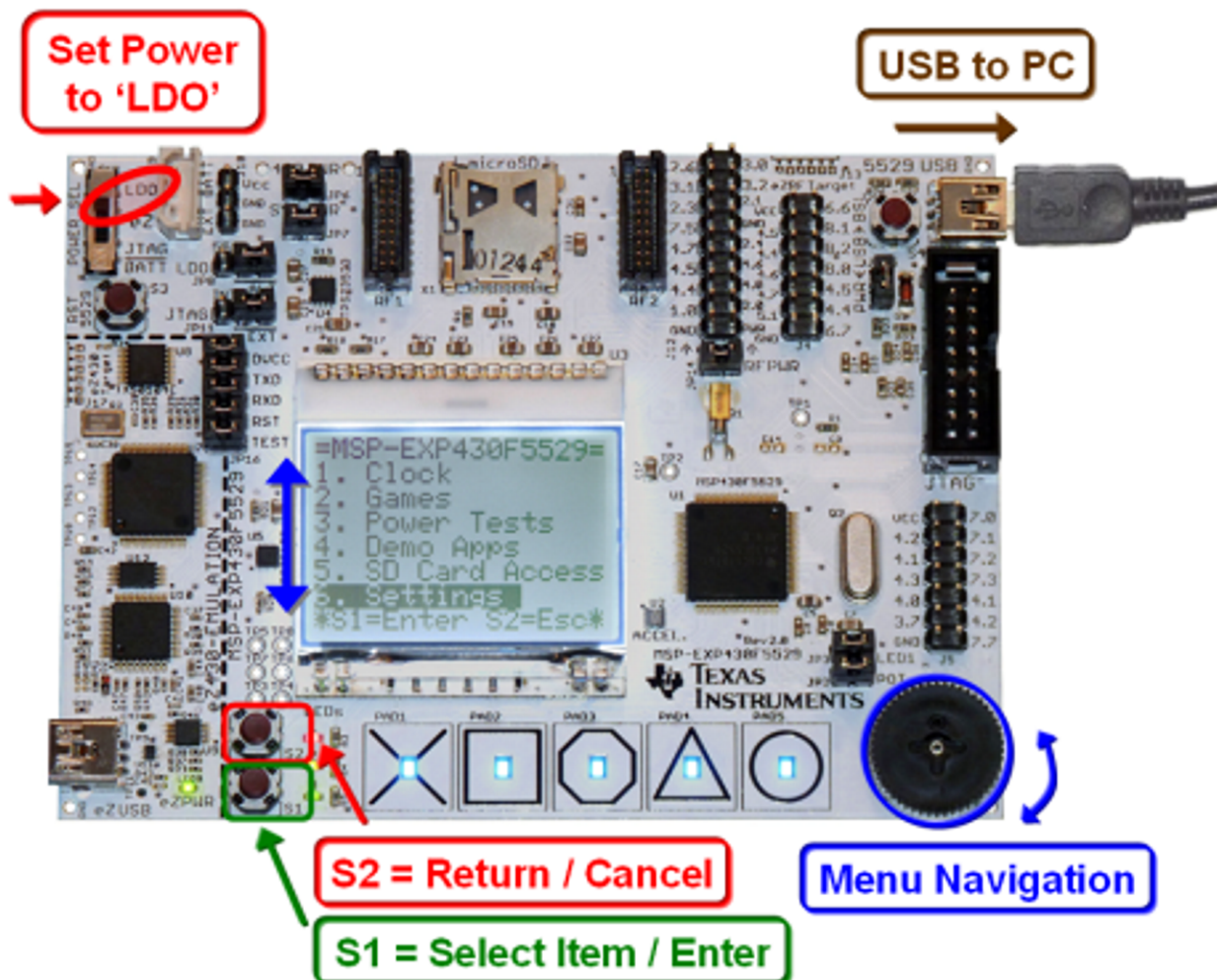

Figure 2. User Experience Navigation

2.2 Main Menu

The main menu displays a list of applications and settings that demonstrate key features of the MSP430F5529. Use the thumb wheel on the bottom right of the PCB to scroll up and down through the menu options. Use the push buttons to enter and exit menu items. Press S1 to enter a menu item. Press S2 to return to a previous menu or to cancel an operation. Each application in the main menu is described in the following sections.

2.3 Clock

Select this option from the main menu to bring up the Clock submenu. Press S2 to return to the previous menu.

NOTE: The User Experience software initializes the real-time clock to 04:30:00 01/01/2011 when powered is applied to the MSP430 MCU.

Digital Clock: Displays an image of a digital watch with the current time and date.

Analog Clock: Displays an image of an analog clock with the current time.

Set Time: Allows the user to set the current time. Use the scroll wheel to change the value of the current selection. Press push-button S1 is used to advance to the next field. The clock changes take affect after the last field is updated.

2.4 Games

Select this option from the main menu to bring up the Games submenu. Press S2 to return to the previous menu.

Defender: The player controls a small spaceship. The object of the game is to fly through a tunnel without hitting the walls and to successfully navigate around mines scattered throughout the tunnel.

Press S1 or S2 to begin the game. Use the wheel to move the ship up and down and press S1 or S2 to shoot a missile. As the game progresses, the tunnel gets narrower and the game speeds up. After the player's ship crashes, the score is displayed.

Simon: A version of the famous memory game. The objective of the game is to match a randomly generated sequence of LEDs displayed on the touch pads. After the sequence is displayed, the user must touch the correct pads in the same sequence.

The game begins with a single-symbol sequence and adds an additional symbol to the sequence after each successful response by the user. The game ends when the user incorrectly enters a sequence. The number of turns obtained in the sequence is then displayed.

Tilt Puzzle: A version of the famous "8-puzzle" game. The game consists of a 3 by 3 grid with eight numbers and one empty space. The game utilizes the on-board accelerometer to shift numbers up-down and left-right. The objective of the game is to have the sum of the numbers in each row and column equal to twelve. Press S1 to begin a new game if the current game is unsolvable. The nature of the game is that there is a 50% probability the game is not solvable.

2.5 Power Tests

Select this option from the main menu to bring up the Power Test submenu. Press S2 to return to the previous menu.

The Power Test menu contains two demonstrations that allow the user to externally measure the current consumption of the MSP430 in both active mode and low-power mode. Current consumption can be measured using a multimeter with current measuring capabilities (ammeter). Remove the jumper on "430 PWR" (JP6) and connect a multimeter in series with the MSP430 V_{CC} supply. This connection can be made using the two large vias near the "430 PWR" text on the PCB. See [Section 4](#) for more details on this connection.

Active Mode: Demo for measuring active mode current of the MSP430. Instructions are presented on screen. Press S1 to continue to the application.

Press S2 to return to the Power Tests submenu.

The Active Mode menu consists of two columns. The left column controls the core voltage (V_{CORE}) of the MSP430F5529, and the right column controls MCLK. The right column displays only those MCLK frequencies that are valid for the current V_{CORE} setting. The capacitive touch pads at the bottom of the board control which column is currently active. The wheel scrolls through the options in the active column.

Press S1 to enter Measurement Mode. While in measurement mode, measure the current by attaching a multimeter across the 430 PWR holes and removing the 430 PWR jumper J6. Replace the 430 PWR jumper after making the measurement, then press S1 or S2 to return to the Active Mode menu.

Press S2 to return to the Power Tests submenu

Low Power Mode: Selecting Low Power Mode takes the user to an information screen with directions on how to navigate the Low Power Mode menu. Press S1 to continue on to the application.

Press S2 to return to the Power Tests submenu.

In the Low Power Mode menu, use the wheel to select a low-power mode option, then press S1 to enter low-power mode. While in low-power mode, measure the current by attaching a multimeter across the 430 PWR holes and removing the 430 PWR jumper.

Press S1 or S2 to return to the Low Power Mode menu.

2.6 Demo Apps

Select this option from the main menu to bring up the Demo Apps submenu, which allows access to various demo applications. Many of them require a USB connection. Use the wheel to select one of the options and then press S1 to enter the application. Press S2 to return to the main menu.

Terminal Echo uses the CDC stack to communicate with a hyperterminal on the PC. USB Mouse uses the HID stack to interface with the PC.

Terminal Echo: Select Terminal Echo to display an informational screen and connects to the PC. Make sure to connect a USB cable from the USB port labeled "5529 USB" to the host PC. Open a hyperterminal window and connect to the MSP430. Text that is typed in the hyperterminal window is echoed back to the terminal and is displayed on the LCD screen of the Experimenter's Board.

Press S2 to exit and return Demo Apps submenu.

USB Mouse: Select USB Mouse to display an informational screen and connects to the PC. Make sure to connect a USB cable from the USB port labeled "5529 USB" to the host PC. The MSP430 now acts as the mouse for the PC. Tilt the board to move the mouse around the screen, and press S1 to click.

Press S2 to exit and return Demo Apps submenu.

USB microSD: Select USB microSD to connect to the PC as a mass storage device. Make sure to connect a USB cable from the USB port labeled "5529 USB" to the host PC. The MSP430 shows as an external drive (or removable drive) for the PC.

Press S2 to return to the Demo Apps submenu.

Touch Graph: Select Touch Graph to display an instruction screen for a very short time and then launch the application. Touch the capacitor key pads with varying pressures to see the varying capacitance being displayed as bars with varying heights. Slide a finger over multiple capacitor key pads to observe the change in heights of bars with respect to the current position of the finger and also the effect of capacitance from neighboring pads.

Press S2 to exit and return Demo Apps submenu.

Touch Slide: Select Touch Slide to display an instruction screen for a very short time and then launch the application. Touch the capacitor key pads with varying pressures to see the varying capacitance being displayed as bars with varying heights. Slide a finger over multiple capacitor key pads to observe the change in heights of bars with respect to the current position of the finger and also the effect of capacitance from neighboring pads.

Press S2 to exit and return Demo Apps submenu.

Demo Cube: Select Demo Cube to launch the demo cube application. Read the instructions and press S1 to start the application. There are two modes. Use S1 to toggle between them.

In the first mode, the cube randomly rotates by itself. In the second mode, the cube can be rotated by tilting the board. This mode uses the accelerometer.

Press S2 to exit and return Demo Apps submenu.

2.7 SD Card Access

Select SD Card Access to access a microSD card placed in the SD card reader at the top of the board. If no SD card is present, a warning screen is displayed. When an SD card is present, the screen displays a list of the contents of the card. Directories are denoted by "<d>". Use the wheel to scroll through the list and select files or directories to open by pressing S1. When a file is open, use the wheel to scroll further through the file. Press S2 to close the current file or directory.

Press S2 while in the root directory to return to the main menu.

2.8 Settings Menu

Select Settings to modify the display settings for the Experimenter's Board. Use the wheel to select the setting to modify and press S1 to enter.

Press S2 to return to the main menu.

Contrast: Modify the contrast of the LCD by turning the wheel. When first entering the menu, the contrast remains unchanged for a few seconds to allow the user to read the instructions and then changes to the setting for the current position of the wheel.

After the contrast is set at the desired level, press S2 to return to the Settings submenu.

Backlight: Modify the brightness of the backlight by turning the wheel. There are 12 brightness settings, from having the backlight turned off up to full brightness.

After the backlight is set at the desired level, press S2 to return to the Settings submenu.

Calibrate Accel: Sets the "default" position for the accelerometer. An instruction screen is shown first. For best results, set the board on a flat surface. Press S1 to start calibrations. The accelerometer readings at that point in time are stored to flash and are subtracted from the subsequent accelerometer readings of other applications like USB Mouse and USB Tilt Puzzle.

SW Version: Displays the current version of the firmware loaded on the Experimenter's Board.

LEDs & Logo: Lights all the LEDs on the board. There are one red, one yellow, one green, and five blue LEDs on the capacitive touch pads. This provides a method to determine whether or not all the LEDs are in working condition.

The screen also displays the TI Bug and a USB Flash Drive logo on the screen.

3 Software Installation and Debugging

3.1 Software

Texas Instruments' Code Composer Studio (CCS) is an MSP430 integrated development environment (IDE) designed specifically to develop applications and program MSP430 devices. CCS, CCS Core Edition, and IAR Embedded Workbench can all be used to evaluate the example software for the Experimenter's Board. The compiler limitation of 8KB prevents IAR KickStart from being used for the evaluation of the example software. The example software, titled "User Experience," is available online as [MSP-EXP430F5529 Experimenter's Board User Experience Software](#).

3.2 Download the Required Software

Different development software tools are available for the MSP-EXP430F5529 Experimenter's Board development board. [Code Composer Studio IDE](#) and [IAR Embedded Workbench for MSP430 \(EW430\)](#) are both available in a free limited version. The software is available at www.ti.com/msp430.

The firmware is larger than IAR KickStart's 8KB limit, so a full license of IAR Workbench is required to compile the application using IAR. A 30-day evaluation version of IAR is also available from <http://supp.iar.com/Download/SW/?item=EW430-EVAL>. This document describes working with Code Composer Studio (CCS).

There are many other compilers and integrated development environments (IDEs) for MSP430 that can be used with the MSP-EXP430F5529 Experimenter's Board, including Rowley Crossworks and MSPGCC. However, the example project has been created using Code Composer Studio IDE and EW430. For more information on the supported software and the latest code examples visit the [MSP-EXP430F5529 product folder](#).

3.3 Working With the Example Software

The MSP-EXP430F5529 example software is written in C and offers APIs to control the MSP430F5529 chip and external components on the MSP-EXP430F5529 Experimenter's Board. New application development can use this library for guidance.

The example software can be downloaded from the MSP-EXP430F5529 tools page, [MSP-EXP430F5529 Experimenter's Board User Experience Software](#). The zip package includes the MSP-EXP430F5529 example software. The code is ready for compilation and execution.

To modify, compile, and debug the example code the following steps should be followed:

1. If you have not already done so, download the sample code from the [MSP-EXP430F5529 tools page](#).
2. Install 5529UE-x.xx-Setup.exe installation package to the PC.
3. Connect the MSP-FET430UIF programmer to the PC. If you have not already done so, install the drivers for the programmer.
4. Connect one end of the 14-pin cable to JTAG programmer and another end to the JTAG header on the board.
5. Open CCS and select a workspace directory (see [Figure 3](#)).

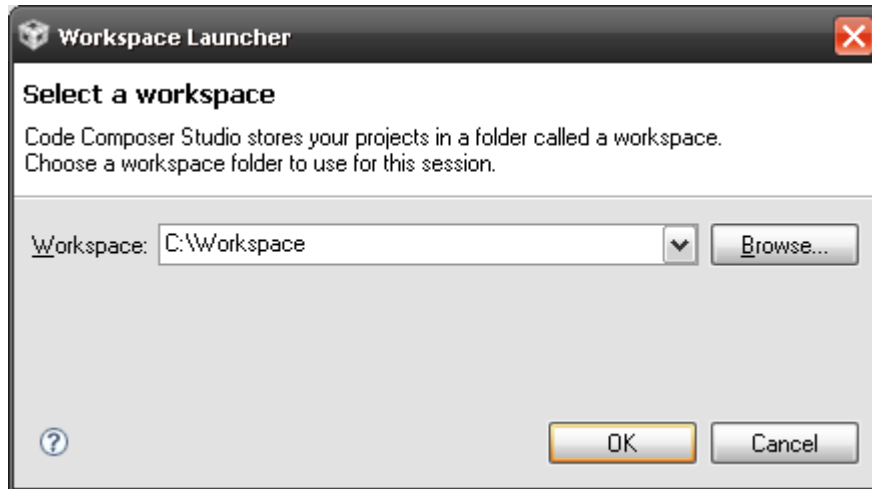

Figure 3. Selecting a CCS Workspace

- Select Project > Import Existing CCS/CCE Eclipse Project.
- Browse to the extracted project directory. The project should now show up in the Projects list (see [Figure 4](#)).
- Make sure the project is selected, and click Finish.

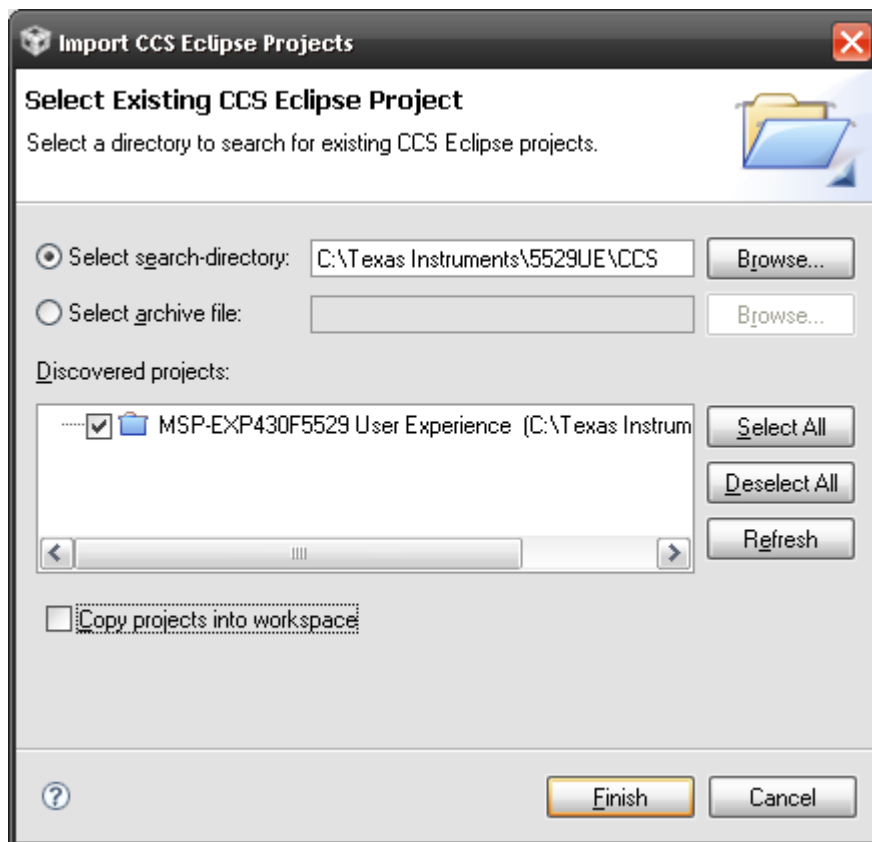

Figure 4. Opening Existing Project

The project is now open. To build, download, and debug the code on the device on the MSP-EXP430F5529 Experimenter's Board, select Target > Debug Active Project or click the green 'bug' button.

You may be prompted to update the firmware on the MSP-FET430UIF programmer. Do not be concerned; click the button that says Update, and the program download should continue as expected.

NOTE: To begin developing your own application, follow these steps:

1. Download and install a supported IDE:
Code Composer Studio – Free 16KB IDE: www.ti.com/ccs
IAR Embedded Workbench KickStart – Free 8KB IDE: www.ti.com/iar-kickstart
 2. Connect the MSP-EXP430F5529 Experimenter's Board "eZ-FET" USB to the PC.
 3. Download and debug your application.
-

3.3.1 Basic Code Structure

CTS	"Capacitive Touch Sensing" library with functions related to the capacitive touch pads.
CCS	CCS-specific project files
CCS_Code_Size_Limited	CCS-specific project files for 16kb code size limited version
F5xx_F6xx_Core_Lib	Core Libraries
FatFs	Stack for the FAT file system used by SD Card
IAR	IAR-specific project files
MSP-EXP430F5529_HAL	Provides an abstraction layer for events like button presses, etc.
HAL_AppUart	Functions for controlling application UART
HAL_Board	Experimenter's Board port initialization and control
HAL_Buttons	Driver for the buttons on the Experimenter's Board
HAL_Cma3000	Functions required to use on-board accelerometer
HAL_Dogs102x6	Driver for the DOGS 102x64 display
HAL_Menu	Used to create the menus for the example software and applications
HAL_SDCard	Driver for the SD Card module
HAL_Wheel	Driver for the scroll (thumb) wheel
USB	USB stack for the Experimenter's Board
UserExperienceDemo	Files related to the example software provided with the board
5xx_ACTIVE_test	Runs a RAM test
Clock	Displays analog and digital clocks. Also provides a function to set time and date.
Demo_Cube	Displays a auto/manual rotating cube (uses accelerometer)
DemoApps	Contains the demos for capacitive touch
EchoUsb	HyperTerminal application
LPM	Provides options for various low-power modes
MassStorage	Use microSD as external storage on computer
menuGames	Play LaunchPad Defender or Simon
Puzzle	Play Tilt-puzzle
Mouse	Use the Experimenter's Board as a mouse
PMM	Active low-power modes. Choose V_{CORE} and MCLK settings.
PowerTest	Test the current consumption of various low-power modes
Random	Random number generator
SDCard	Access microSD card contents on the Experimenter's Board
Settings	Options to set various parameters like contrast, brightness, etc.
UserExperience.c	Main MSP-EXP430F5529 Experimenter's Board file
MSP-EXP430F5529 User Experience Manifest.pdf	
readme.txt	

4 MSP-EXP430F5529 Hardware

4.1 Hardware Overview

Figure 5 and Figure 6 show the functional blocks and connections of the MSP-EXP430F5529 Experimenter's Board. The area of the PCB labeled as "eZ430-FET Emulator" and bordered by a thick broken line on the PCB silk screen is an integrated TI Flash Emulation Tool (FET) which is connected to the Experimenter's Board by the jumpers on JP16. This module is similar to any eZ430 emulator, and provides real-time in-system Spy-Bi-Wire programming and debugging through a USB connection to a PC. Using the eZ430-FET Emulator module eliminates the need for using an external MSP430 Flash Emulation Tool (MSP-FET430UIF). However, full speed 4-wire JTAG communication is only possible with a MSP-FET430UIF connected to the "5529 JTAG" header. For additional details on the installation and usage of the Flash Emulation Tool, Spy-Bi-Wire and JTAG, see the [MSP430 Hardware Tools User's Guide](#).

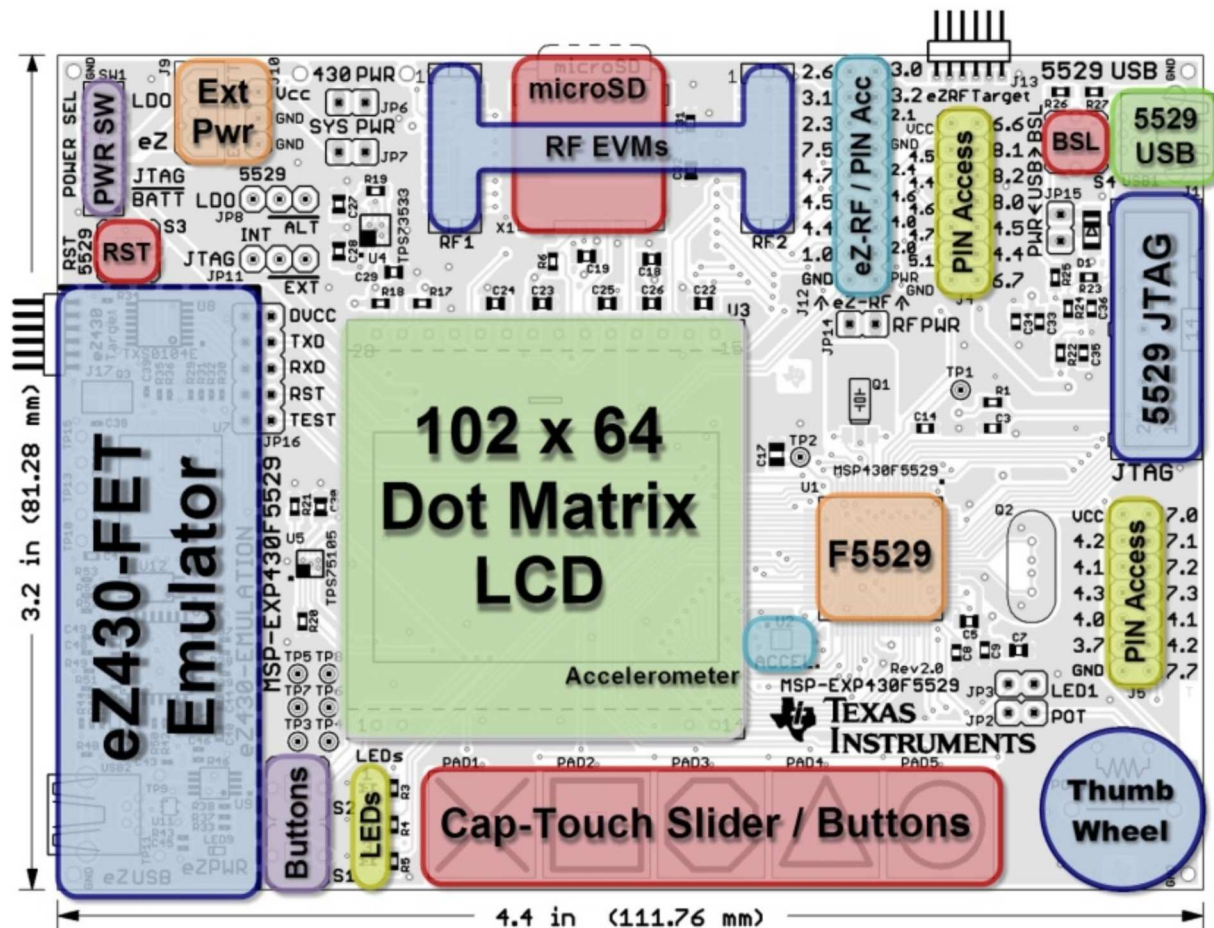

Figure 5. Simple Hardware Overview

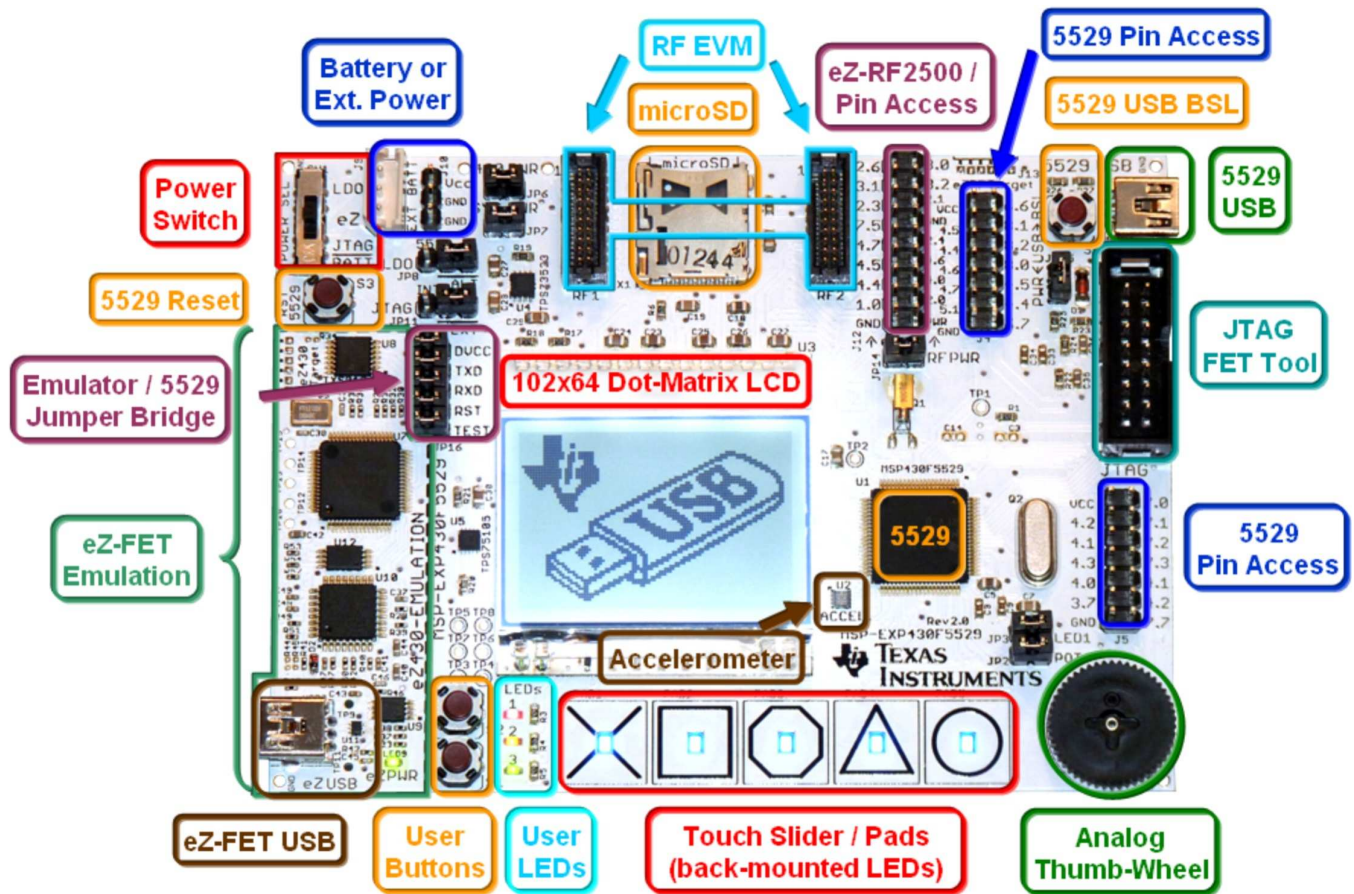

Figure 6. Hardware Block Details

4.2 Jumper Settings and Power

Figure 7 shows the common jumper settings, depending on the power source for the MSP-EXP430F5529 Experimenter's Board.

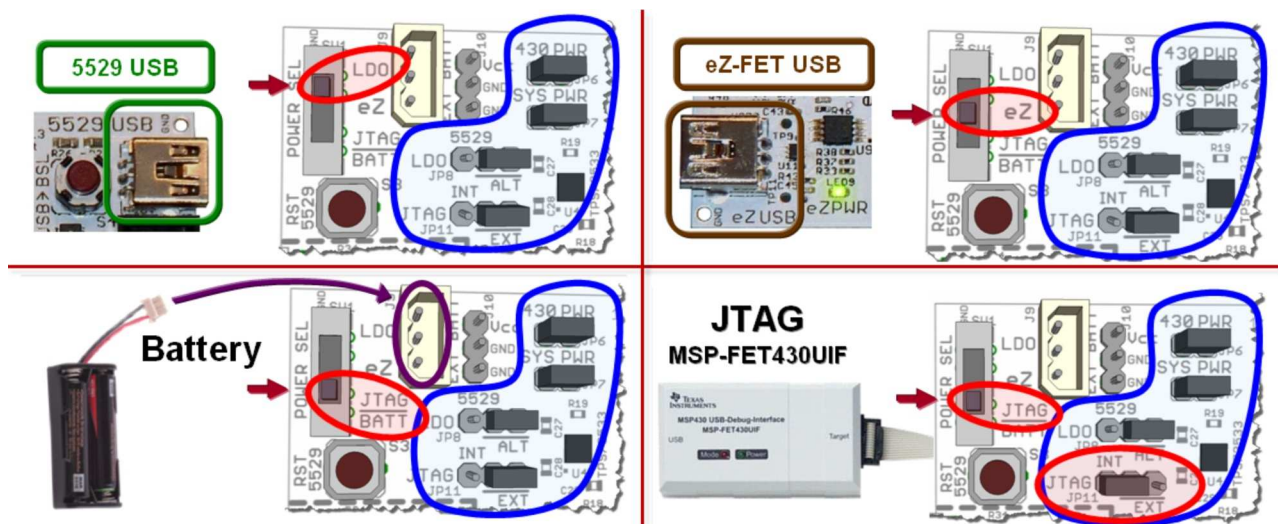

Figure 7. Common Power Jumper Settings

There are also other jumpers available for current measurement, disconnection of certain peripherals, and other advanced options (see [Table 1](#)). The black line on the board below the jumpers JP8 (LDO) and JP11 (JTAG) indicates the default jumper position.

Table 1. MSP-EXP430F5529 Jumper Settings and Functionality

Header	Functionality When Jumper Present	Functionality When Jumper Absent
JP2 – POT	Connects pin P8.0 to potentiometer	Disconnects pin P8.0 to potentiometer
JP3 – LED1	Connects pin P1.0 to LED1	Disconnects pin P1.0 to LED1
JP6 – 430 PWR	Provides power to MSP430F5529. Also used to measure current consumption of the MSP430F5529. NOTE: The two large vias near the "430 PWR" label on the PCB are connected to JP6 as well. These vias can be used to easily connect a test lead onto the PCB for current consumption measurement.	MSP430F5529 is not powered.
JP7 – SYS PWR	Provides power to the entire MSP-EXP430F5529 board. Also used to measure current consumption of the entire board.	MSP-EXP430F5529 Experimenter's Board system devices are not powered.
JP8 – LDO	Only applicable when powering through "5529 USB" connection. ALT (Default): Connects the alternate LDO (TPS73533) to the MSP430 VCC. INT: Connects the internal 'F5529 LDO to the MSP430 VCC.	No connection to MSP430 V _{CC} when powered through "5529 USB".
JP11 – JTAG	Only applicable when powering through JTAG connection. EXT (Default): JTAG tool does NOT provide power to system. INT: JTAG tool will provide power to system.	JTAG tool does NOT provide power to system.
JP14 – RF PWR	Connects system V _{CC} to the RF headers: J12, J13, and RF2.	RF headers: J12, J13, and RF2 do not have power.
JP15 – USB PWR	Connects USB 5-V power to MSP430F5529 and Alternate LDO (TPS73533).	USB 5-V power not connected to system.
JP16 – eZ-FET Connection	DVCC: Connects MSP430 V _{CC} to eZ-FET TXD / RXD: Connects UART between F5529 and eZ-FET. RST / TEST: Connects Spy-Bi-Wire JTAG between F5529 and eZ-FET.	No connection between MSP430F5529 and the eZ-FET.

Figure 8 shows a visual diagram of the power connections for the MSP-EXP430F5529 Experimenter's Board. Care should be observed when using multiple power sources such as USB and a battery at the same time. This could lead to the battery being charged if the power settings are not correct.

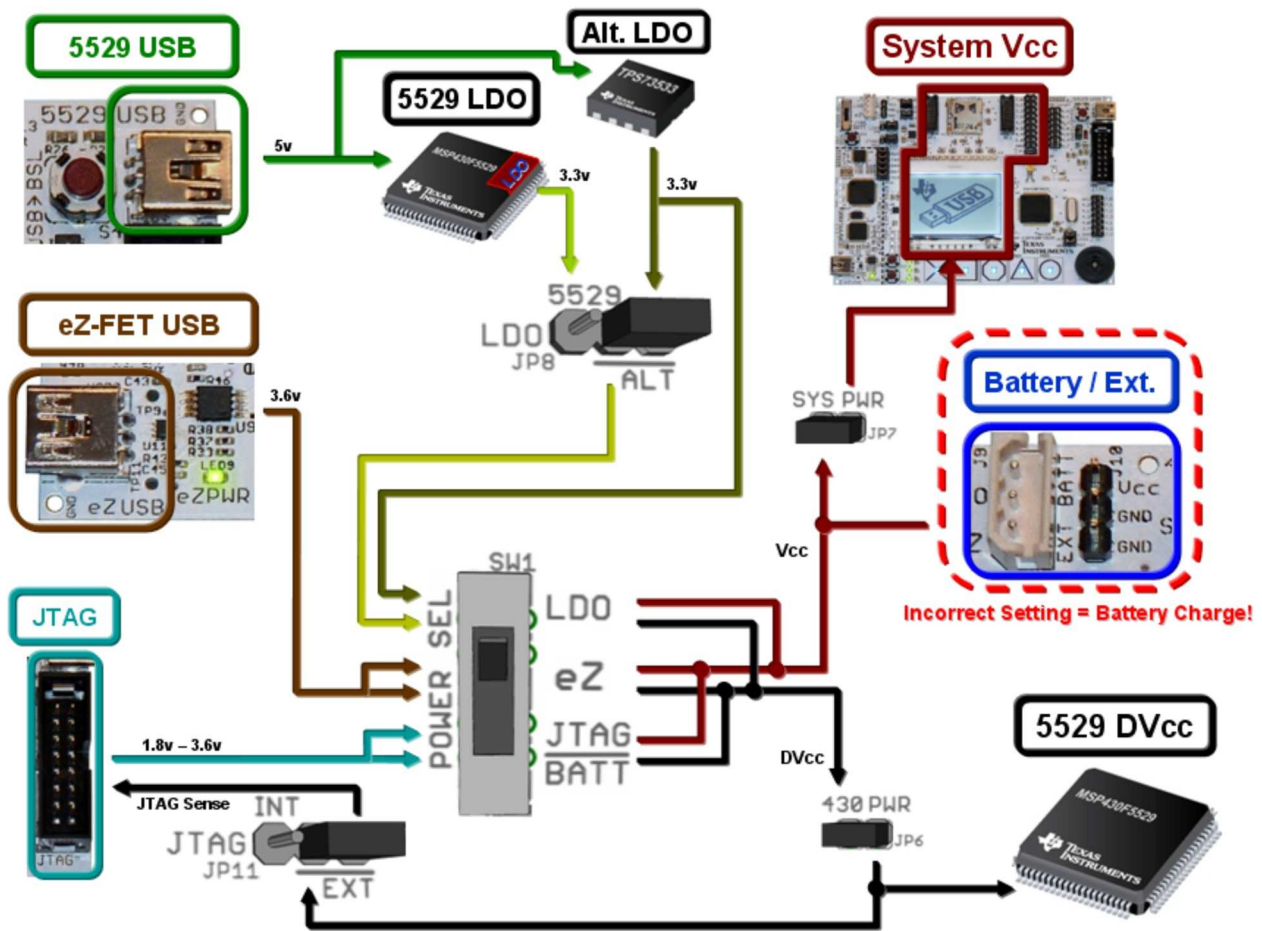

Figure 8. Visual Power Schematic

Figure 9 shows a method of connecting a multimeter to the MSP-EXP430F5529 to measure the current of the MSP430F5529.

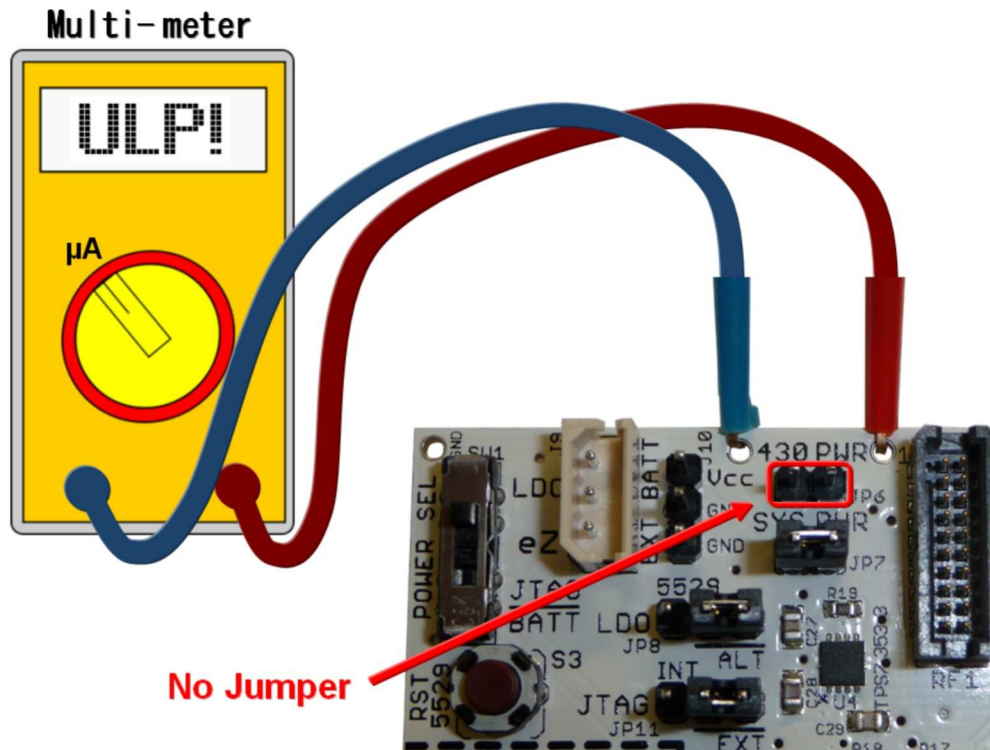

Figure 9. MSP430 Current Measurement Connection

4.3 eZ-FET Emulator

The connection between the eZ-FET emulator and the MSP-EXP430F5529 can be opened by removing the jumpers on JP16. This is necessary only to ensure there is no interaction between the two sub-systems. The eZ-FET Emulator can program other eZ430 tools such as the eZ430-F2013 target board as well. A six-pin header on J17 would need to be installed on the PCB for this feature.

The USB interface on the eZ-FET emulator also allows for UART communication with a PC host, in addition to providing power to Experimenter's Board when the power switch is set to 'eZ'. The USCI module in the MSP430F5529 supports the UART protocol that is used to communicate with the TI TUSB3410 device on the eZ-FET emulator for data transfer to the PC.

4.4 MSP-EXP430F5529 Hardware Components

4.4.1 Dot-Matrix LCD

The EA DOGS102W-6 is a dot-matrix LCD with a resolution of 102x64 pixels. The LCD has a built-in back-light driver that can be controlled by a PWM signal from the MSP430F5529, pin P7.6. The MSP430F5529 communicates with the EA DOGS102W-6 through an SPI-like communication protocol. To supplement the limited set of instructions and functionalities provided by the on-chip LCD driver, an LCD driver has been developed for the MSP430F5529 to support additional functionalities such as font set and graphical utilities. More information on the LCD can be obtained from the manufacturer's data sheet.

4.4.2 Push Buttons, Potentiometer, and LEDs

Table 2 describes the pin connections for the potentiometer, push-button switches, and the on-board LEDs.

Table 2. Push Buttons, Potentiometer, and LED Connections

Peripheral	Pin Connection
Potentiometer Wheel	P8.0
Switch 1 (S1)	P1.7
Switch 2 (S2)	P2.2
RESET Switch (S3)	$\overline{\text{RST}}/\text{NMI}$
LED1	P1.0
LED2	P8.1
LED3	P8.3
Capacitive Touch Pad 1 (Cross)	P1.1
Capacitive Touch Pad 2 (Square)	P1.2
Capacitive Touch Pad 3 (Octagon)	P1.3
Capacitive Touch Pad 4 (Triangle)	P1.4
Capacitive Touch Pad 5 (Circle)	P1.5

4.4.3 Wireless Evaluation Module Interface

Included in the communication peripherals are the headers that support the CC-EM boards from TI. The transceiver modules connect to the USCI of the MSP430F5529 configured in SPI mode using the UCB0 peripheral. Libraries that interface the MSP430 to these transceivers are available at www.ti.com/msp430 under the Code Examples tab. The RF PWR jumper must be populated to provide power to the EM daughterboard. The following radio daughter cards are compatible with the MSP-EXP430F5529 Experimenter's Board:

- CC1100EMK/CC1101EMK – Sub-1-GHz radio
- CC2500EMK – 2.4-GHz radio
- CC2420EMK/CC2430EMK – 2.4-GHz 802.15.4 [SoC] radio
- CC2520EMK/CC2530EMK – 2.4-GHz 802.15.4 [SoC] radio
- CC2520 + CC2591 EM (if R4 and R8 0-Ω resistors are connected)

NOTE: Future evaluation boards may also be compatible with the header connections.

4.4.4 eZ430-RF2500T Interface

The eZ430-RF2500T module can be attached to the MSP-EXP430F5529 Experimenter's Board in one of two ways – through an 18-pin connector (J12 – eZ RF) or a 6-pin connector (J13 – eZ RF Target). The pins on the eZ430-RF2500T headers are multiplexed with the pins on the CC-EM headers, which allows the EZ430-RF2500T module to behave identically to a CC-EM daughterboard. Power must be provided to the EZ430-RF2500T module by setting the jumper RF PWR (JP14). The eZ430-RF2500T connection should always be made with the antenna facing off of the board. For more information on the connections to the required eZ430-RF2500T, see the [eZ430-RF2500 Development Tool User's Guide](#), available through www.ti.com/eZ430.

4.4.5 3-Axis Accelerometer

The MSP-EXP430F5529 Experimenter's Board includes a VTI digital 3-axis accelerometer (part number CMA3000-D01). The accelerometer supports SPI communication and outputs data for each X, Y and Z axis. The accelerometer is powered through pin P3.6. This interface, especially in conjunction with other on-board interfaces such as the LCD, enables several potential applications such as USB mouse movement emulation and tilt sensing. The example software used the accelerometer for the Tilt Puzzle, Demo Cube, and USB Mouse. For more information on the accelerometer chip, see the manufacturer's data sheet (<http://www.vti.fi>).

4.4.6 Pin Access Headers

The MSP-EXP430F5529 Experimenter's Boards includes three headers (J4, J5, and J12) that can be used as additional connections to external hardware or for signal analysis during firmware development. All pins except the GND pin are internally selectable as either general purpose input/output pins or as described in the device datasheet.

Table 3. Pinning Mapping for Header J4

Pin Description	Port Pin	Port Pin	Pin Description
Vcc	VCC	P6.6	CB6 / A6
UCA1RXD / UCA1SOMI	P4.5	P8.1	GPIO – LED2
UCA1TXD / UCA1SIMO	P4.4	P8.2	GPIO – LED3
GPIO	P4.6	P8.0	GPIO – POT
GPIO	P4.7	P4.5	UCA1RXD / UCA1SOMI
A9 / VREF- / VeREF-	P5.1	P4.4	UCA1TXD / UCA1SIMO
GND	GND	P6.7	CB7 / A7

Table 4. Pin Mapping for Header J5

Pin Description	Port Pin	Port Pin	Pin Description
VCC	VCC	P7.0	CB8 / A12
UCB1SOMI / UCB1SCL - SD	P4.2	P7.1	CB9 / A13
UCB1SIMO / UCB1SDA - LCD/SD	P4.1	P7.2	CB10 / A14
UCB1CLK / UCA1STE - LCD/SD	P4.3	P7.3	CB11 / A15
UCB1STE / UCA1CLK - RF	P4.0	P4.1	UCB1SIMO / UCB1SDA - LCD/SD
TB0OUTH / SVMOUT - SD	P3.7	P4.2	UCB1SOMI / UCB1SCL - SD
GND	GND	P7.7	TB0CLK / MCLK

Table 5. Pin Mapping for Header J12

Pin Description	Port Pin	Port Pin	Pin Description
(RF_STE)	P2.6	P3.0	(RF_SIMO)
(RF_SOMI)	P3.1	P3.2	(RF_SPI_CLK)
TA2.0	P2.3	P2.1	TA1.2
TB0.3	P7.5	GND	GND
GPIO	P4.7	P2.4	TA2.1
(RXD)	P4.5	P4.6	GPIO
(TXD)	P4.4	P4.0	UCx1xx
(LED1)	P1.0	P2.0	TA1.1
GND	GND	RF_PWR	RF_PWR

5 Frequently Asked Questions, References, and Schematics

5.1 Frequently Asked Questions

1. Which devices can be programmed with the Experimenter's Board?

The MSP-EXP430F5529 board is designed specifically to demonstrate the MSP430F5529.

2. The MSP430F5529 is no longer accessible through JTAG. Is something wrong with the device?

Verify that the jumpers are configured correctly. See [Section 4](#) for jumper configuration.

Verify that the target device is powered properly.

If the target is powered locally, verify that the supplied V_{CC} is sufficient to power the board. Check the device data sheet for the specification.

3. I did every step in the previous question but still could not use or communicate with the device.

Improper programming of the device could lead to a JTAG total lockup condition. The cause of this problem might be an incorrect device selection when creating a new project in CCS (select MSP430F5529) or programming the device without a stable power source (low battery, switching the Power Selector while programming, or absence of the MSP430 power jumper JP6 during programming).

To solve this, completely reset the device. First unplug all power sources and connections (JTAG and USB cables). Set the Power Selector Switch to FET mode. Use a jumper cable to briefly short one of the GND test points with the 430 PWR test point. The device should now be released from the lockup state.

4. Does the Experimenter board protect against blowing the JTAG fuse of the target device?

No. Fuse blow capability is inherent to all flash-based MSP430 devices to protect user's intellectual property. Care must be taken to avoid the enabling of the fuse blow option during programming, because blowing the fuse would prevent further access to the MSP430 device through JTAG.

5. I am measuring system current in the range of 30 mA, is this normal?

The LCD and the LCD backlight require a large amount of current (approximately 20 mA to 25 mA) to operate. This results in a total system current consumption in the range of 30 mA. If the LCD backlight is on, 30 mA is considered normal.

To ensure the board is OK, disable the LCD and the LCD backlight and measure the current again. The entire board current consumption should not exceed 10 mA at this state. Note that the current consumption of the board could vary greatly depending on the optimization of the board configurations and the applications.

The expected current consumption for the MSP430F5529 in standby mode (LPM3), for example, is approximately 2 μ A. Operating at 1 MHz, the total current consumption should not exceed approximately 280 μ A.

6. I have trouble reading the LCD clearly. Why is the LCD contrast setting so low?

The LCD contrast is highly dependent on the voltage of the system. Changing power source from USB (3.3 V) to batteries (approximately 3 V) could drastically reduce the contrast. Fortunately, the LCD driver supports adjustable contrast. The specific instruction can be found in the LCD user's guide. The MSP-EXP430F5529 software also provides the function to adjust the contrast using the wheel (see [Section 2.8](#)).

7. When I run the example code, nothing happens on the LCD.

Verify that all jumpers are installed correctly and the 14-pin JTAG cable are properly connected.

5.2 References

1. [MSP430x5xx and MSP430x6xx Family User's Guide](#)
2. [Code Composer Studio \(CCStudio\) Integrated Development Environment \(IDE\)](#)
3. [MSP430 Interface to CC1100/2500 Code Library \(associated files\)](#)

5.3 Schematics and BOM

The following figures show the schematics (download Eagle CAD schematics and Gerber files).

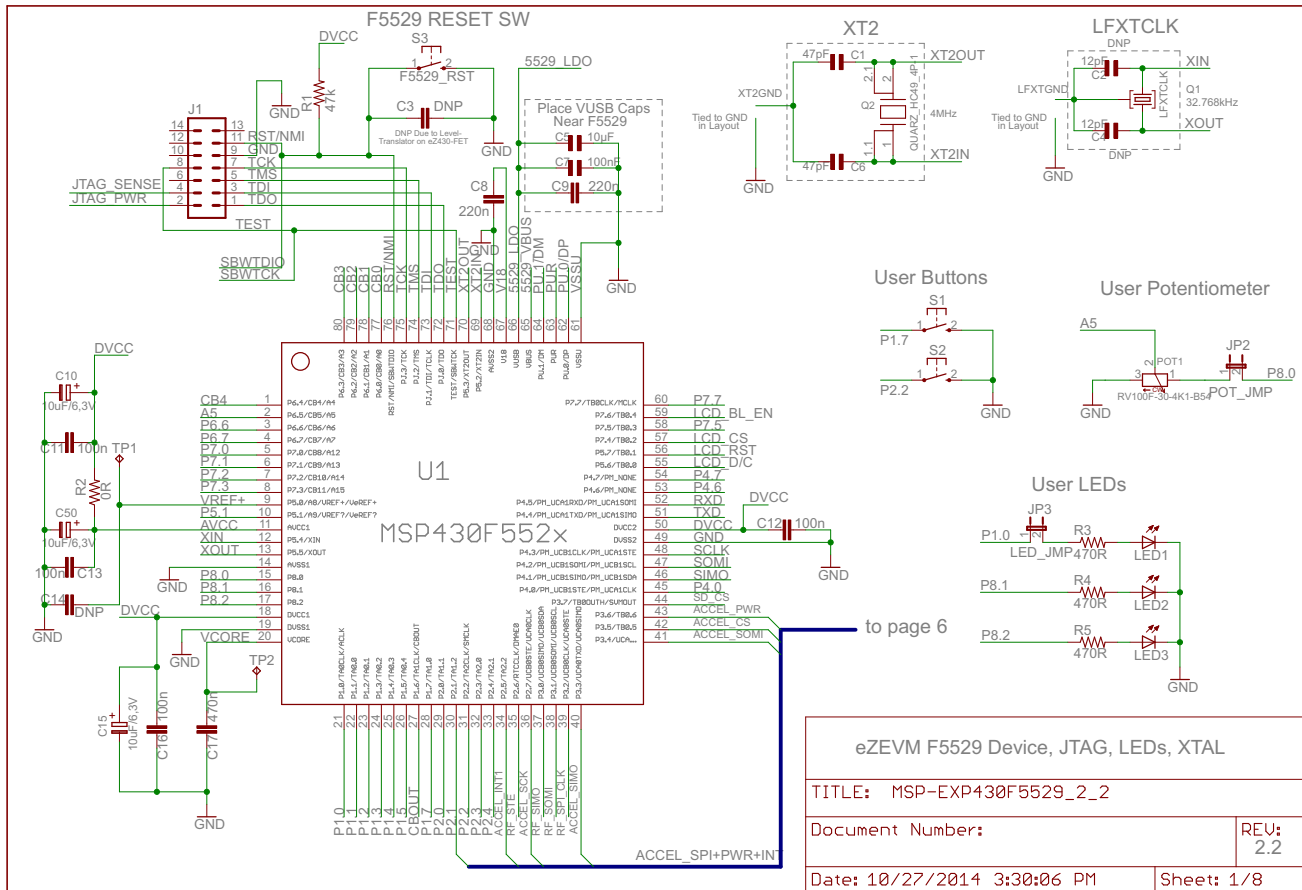

Copyright © 2017, Texas Instruments Incorporated

Figure 10. Schematics (1 of 8)

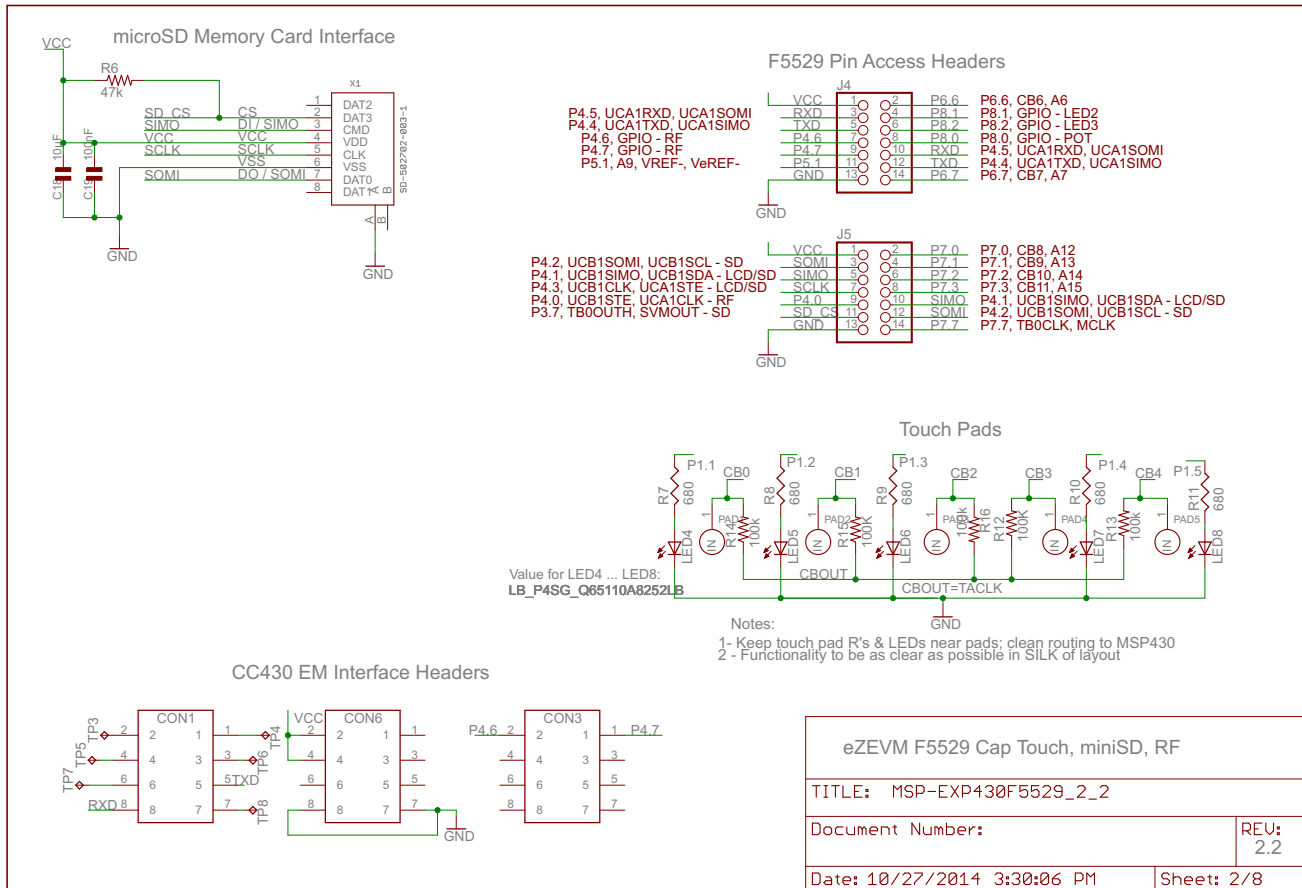

eZEM F5529 Cap Touch, miniSD, RF	
TITLE: MSP-EXP430F5529_2_2	
Document Number:	REV: 2.2
Date: 10/27/2014 3:30:06 PM	Sheet: 2/8

Copyright © 2017, Texas Instruments Incorporated

Figure 11. Schematics (2 of 8)

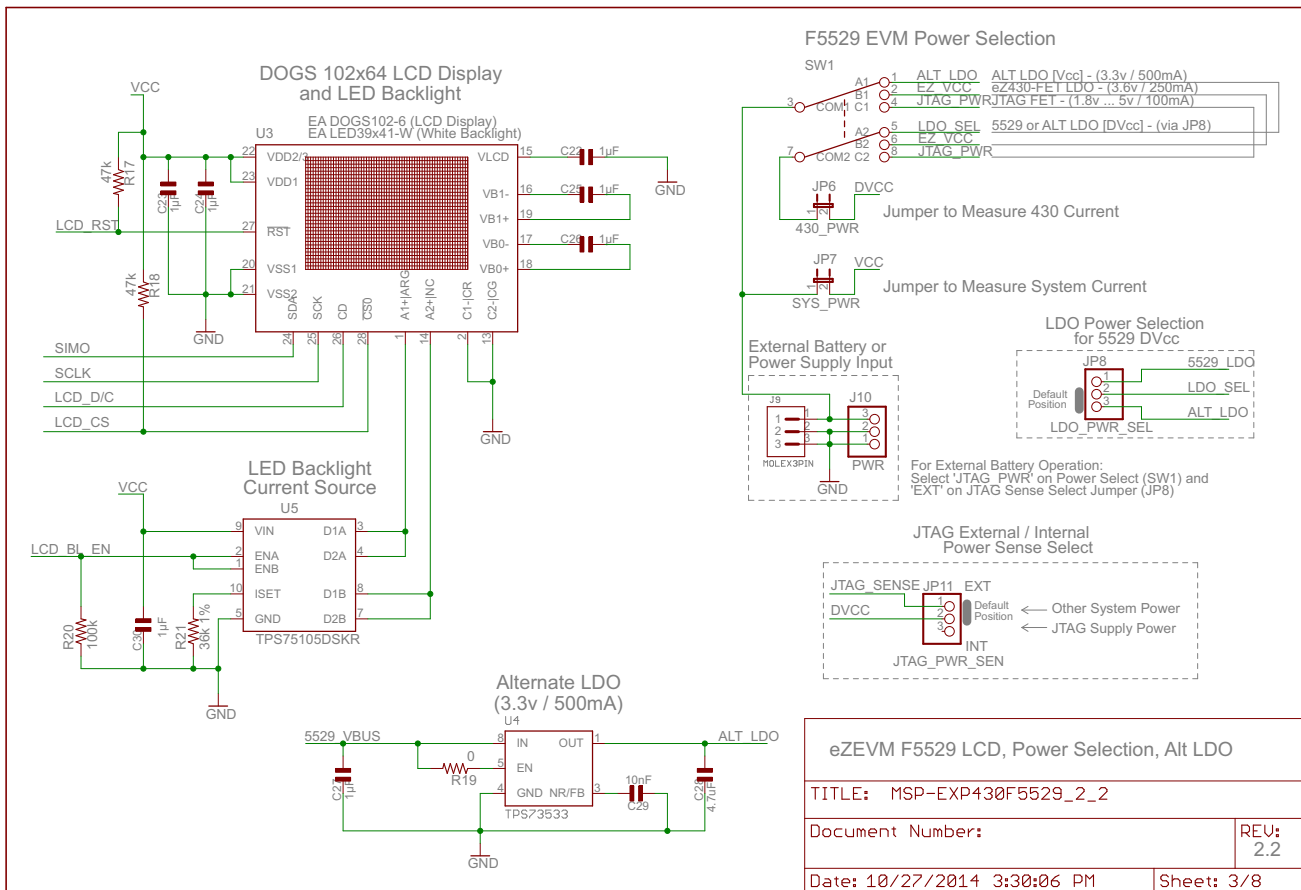

Copyright © 2017, Texas Instruments Incorporated

Figure 12. Schematics (3 of 8)

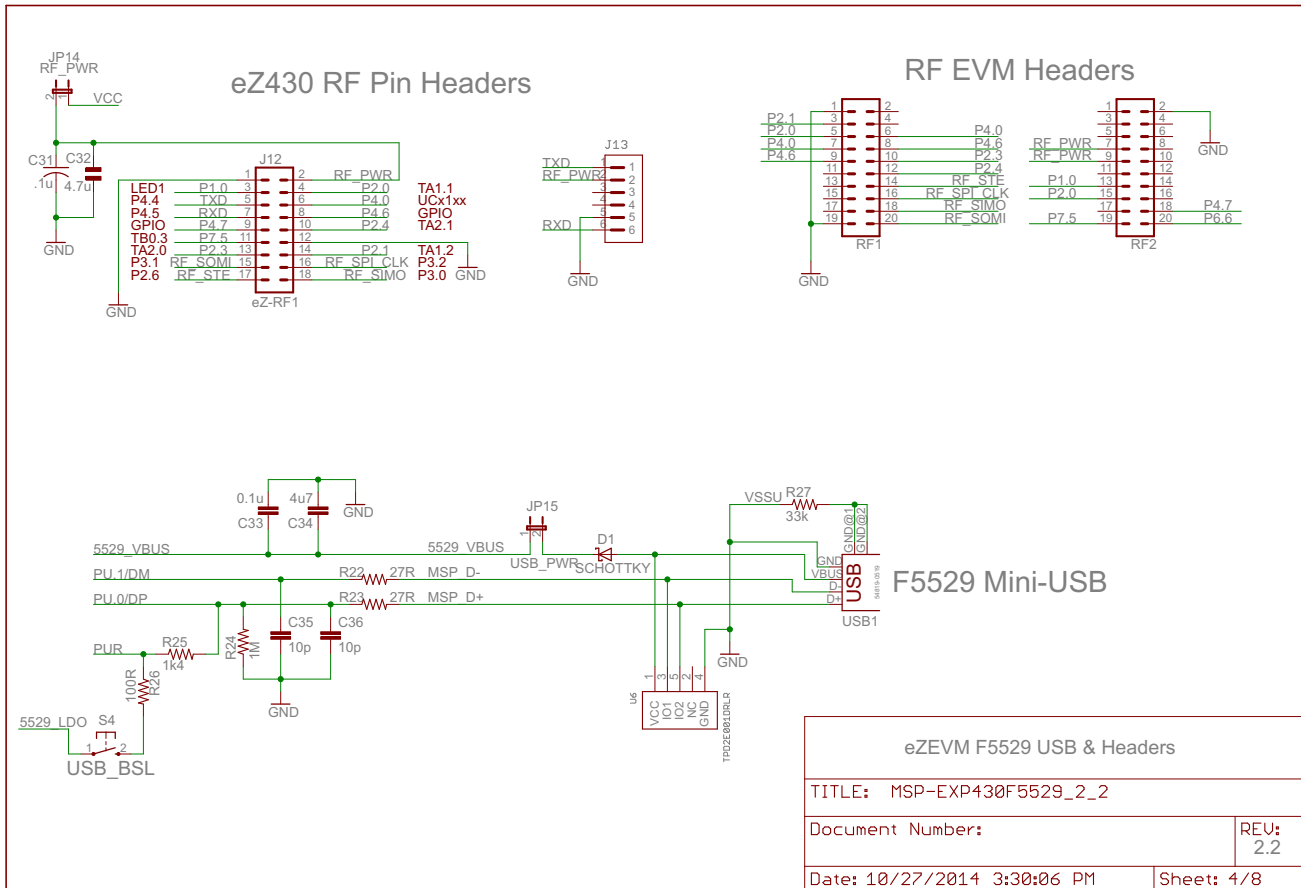

eZEVm F5529 USB & Headers	
TITLE: MSP-EXP430F5529_2_2	
Document Number:	REV: 2.2
Date: 10/27/2014 3:30:06 PM	Sheet: 4/8

Copyright © 2017, Texas Instruments Incorporated

Figure 13. Schematics (4 of 8)

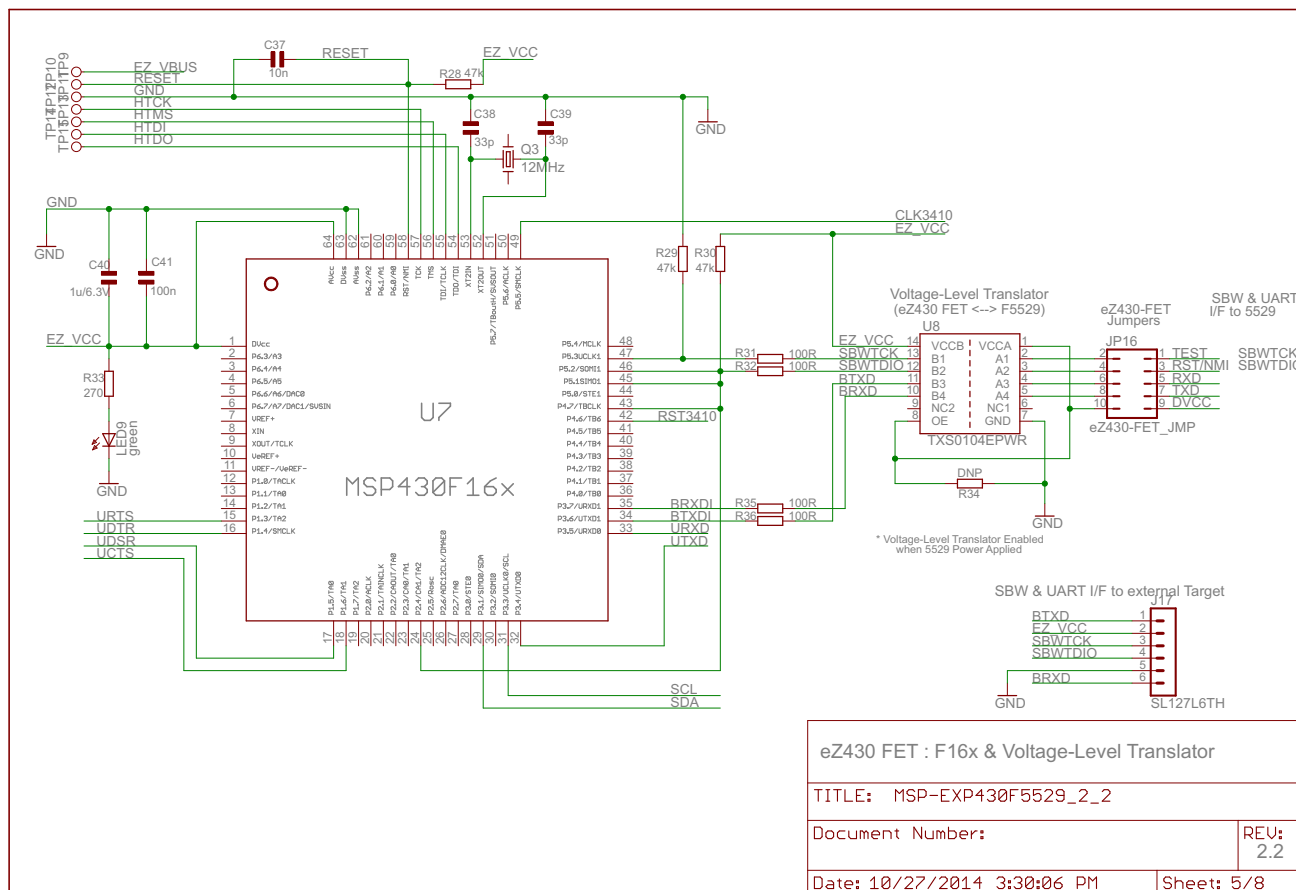
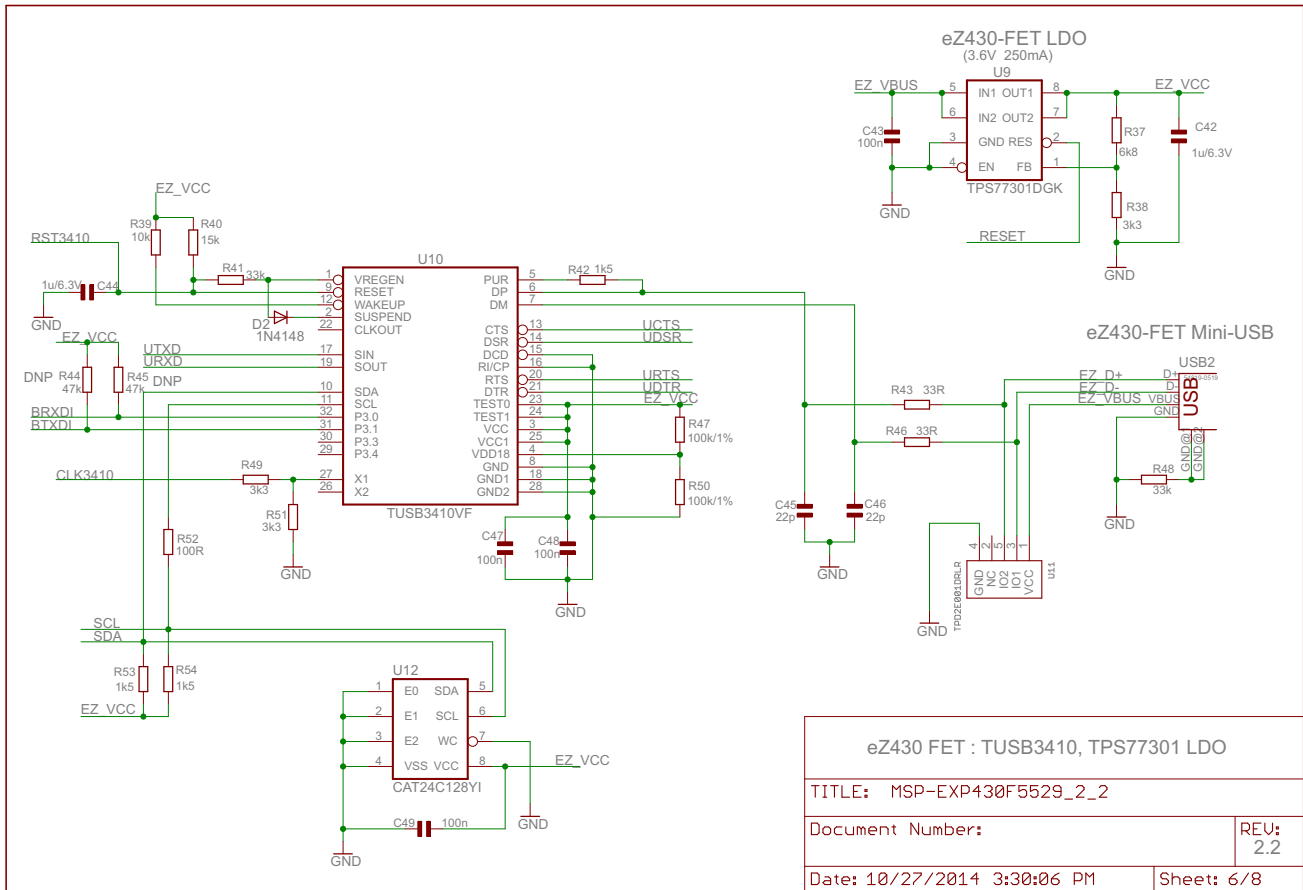
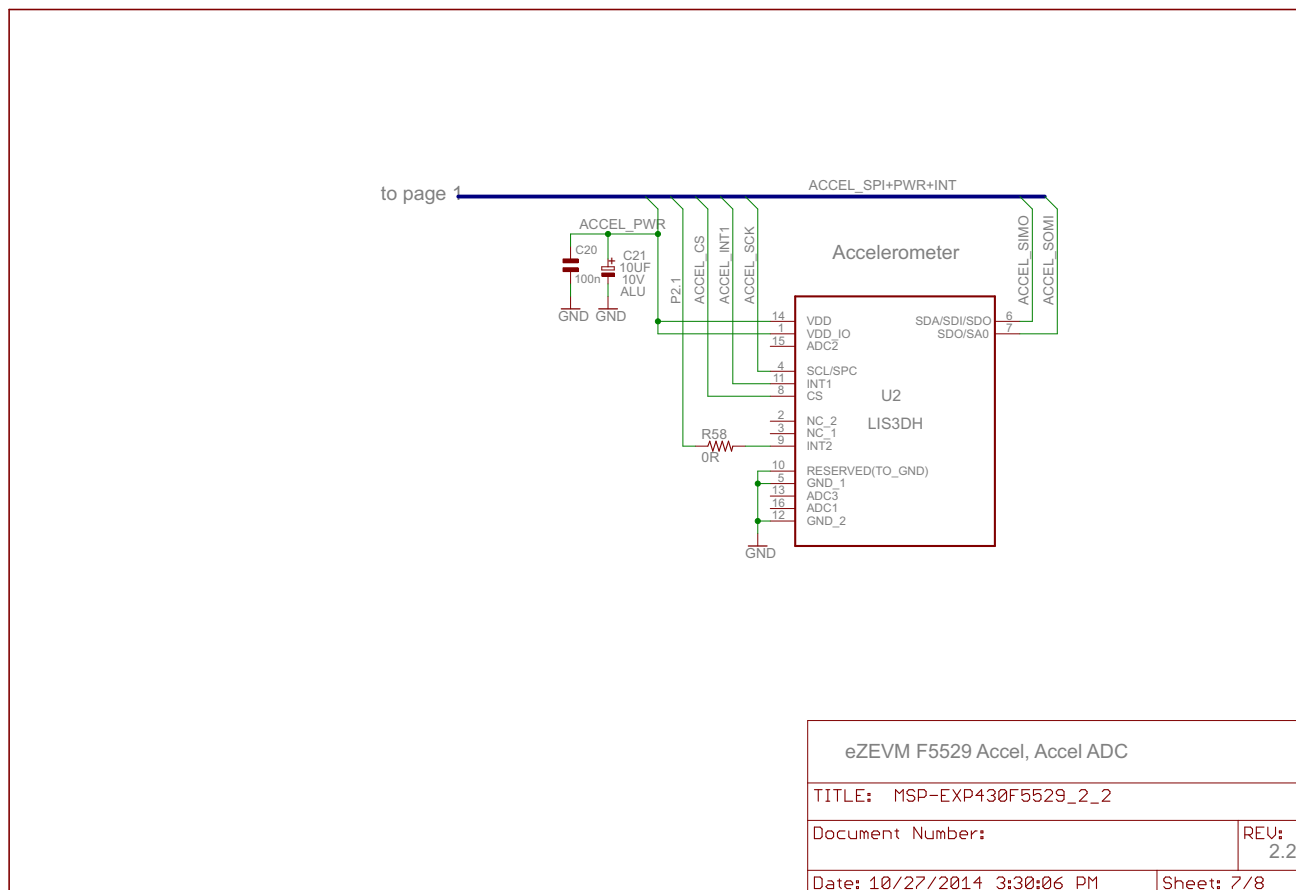

Figure 14. Schematics (5 of 8)



Copyright © 2017, Texas Instruments Incorporated

Figure 15. Schematics (6 of 8)



Copyright © 2017, Texas Instruments Incorporated

Figure 16. Schematics (7 of 8)

Revision History

PCB Revision 2.0
(See PCB Revision 1.0 for Previous Revision History)

09.26.2010

Added e2430-FET to F5529 Voltage-Level Translator (TXS0104E).
 Added Alternate LDO (TPS73533) Option for Vcc System Power.
 Added D0G5 102x64 Dot-Matrix LCD and White LED Backlight.
 Added LED Backlight Driver (TPS75109).
 Modified power selection for Vcc and DVcc.
 Removed extra headers and prototype area.
 Extensive PCB Layout Rearrangement.
 Modified RF Headers for Additional EVM Capability.

PCB Revision 2.1

12.04.2012

Replaced POT1 with another type.

PCB Revision 2.2

27.10.2014

Schematics:
 Accelerometer U2 (formerly CMA3000-D01) replaced by ST LIS3DH
 INT2 of LIS3DH connected to P2.1 (via 0R resistor)
 LED4 ... LED8 new type (different case):
 Osram LBP4SG-S2U1-35-1 Article number: Q65110A8252

TITLE: MSP-EXP430F5529_2_2	
Document Number:	REV: 2.2
Date: 10/27/2014 3:30:06 PM	Sheet: 8/8

Copyright © 2017, Texas Instruments Incorporated

Figure 17. Schematics (8 of 8)

Table 6 lists the bill of materials for the MSP-EXP430F5529 Experimenter's Board.

Table 6. Bill of Materials (BOM)

Part	Value	Package Type	Device
C1	47pF	0805	
C2	12pF	0805	
C3	DNP	0603	
C4	12pF	0805	
C5	10 μ F	0805	
C6	47pF	0805	
C7	100nF	0805	
C8	220n	0603	
C9	220n	0603	
C10	10uF/6,3V	1210	
C11	100n	0603	
C12	100n	0805	
C13	100n	0805	
C14	DNP	0603	
C15	10uF/6,3V	1210	
C16	100n	0805	
C17	470n	0805	
C18	10 μ F	0805	
C19	100nF	0805	
C20	.1u	0603	
C21	10UF	ELKO_B	FK4,7UF/35V-B (FK*)
C22	1 μ F	0805	
C23	1 μ F	0805	
C24	1 μ F	0805	
C25	1 μ F	0805	
C26	1 μ F	0805	
C27	1 μ F	0805	
C28	4.7uF	0805	
C29	10nF	0805	
C30	1 μ F	0805	
C31	.1u	0603	
C32	4.7u	0805	
C33	0.1u	0603	
C34	4u7	0603	
C35	10p	0603	
C36	10p	0603	
C37	10n	0402	
C38	33p	0402	
C39	33p	0402	
C40	1u/6.3V	0603	
C41	100n	0402	
C42	1u/6.3V	0603	
C43	100n	0402	
C44	1u/6.3V	0603	
C45	22p	0402	
C46	22p	0402	

Table 6. Bill of Materials (BOM) (continued)

Part	Value	Package Type	Device
C47	100n	0402	
C48	100n	0402	
C49	100n	0402	
C50	10uF/6,3V	1210	
CON1	8PIN_SM_MA_HEADER	HEADER 2x4 MALE .1" SMD	
CON2	8PIN_SM_MA_HEADER	HEADER 2x4 MALE .1" SMD	
CON3	8PIN_SM_MA_HEADER	HEADER 2x4 MALE .1" SMD	
D1	LLSD103A-7	Mini MELF	
D2	1N4148 Micro MELF	SOD110-R	
J1	103308-2	14-Pin Male JTAG Connector	
JP2	POT_JMP	HEADER 1x2 MALE .1" TH	JP1E\SMALL_PIN
JP3	LED_JMP	HEADER 1x2 MALE .1" TH	JP1E\SMALL_PIN
J4	HEADER - F5529 PIN ACCESS	HEADER 2x7 MALE .1" TH	
J5	HEADER - F5529 PIN ACCESS	HEADER 2x7 MALE .1" TH	
JP6	430_PWR	HEADER 1x2 MALE .1" TH	JP1E
JP7	SYS_PWR	HEADER 1x2 MALE .1" TH	JP1E
JP8	LDO_PWR_SEL	HEADER 1x3 MALE .1" TH	PINH-1X3/SMALL_PIN
J9	22-03-5035	MOLEX 3-PIN MALE HEADER	22-03-5035
J10	HEADER - PWR	HEADER 1x3 MALE .1" TH	PINH-1X3
JP11	JTAG_PWR_SEN	HEADER 1x3 MALE .1" TH	PINH-1X3/SMALL_PIN
J12	eZ-RF1 HEADER - RF2500	HEADER 2x9 MALE .1" TH	
J13	6-Pin Male eZ430 Connector	6-Pin Male eZ430 Connector	SL127L6TH
JP14	RF_PWR	HEADER 1x2 MALE .1" TH	JP1E
JP15	USB_PWR	HEADER 1x2 MALE .1" TH	JP1E
JP16	eZ430-FET_JMP	HEADER 2x5 MALE .1" TH	JP5Q
J17	6-Pin Male eZ430 Connector	6-Pin Male eZ430 Connector	SL127L6TH
LED1	LEDCHIPLED_0603	0603	LEDCHIPLED_0603
LED2	LEDCHIPLED_0603	0603	LEDCHIPLED_0603
LED3	LEDCHIPLED_0603	0603	LEDCHIPLED_0603
LED4	LB_P4SG_Q65110A8252LB	LB_P4SG_Q65110A8252	LB_P4SG_Q65110A8252LB (LB_P4SG_Q65110A8252)
LED5	LB_P4SG_Q65110A8252LB	LB_P4SG_Q65110A8252	LB_P4SG_Q65110A8252LB (LB_P4SG_Q65110A8252)
LED6	LB_P4SG_Q65110A8252LB	LB_P4SG_Q65110A8252	LB_P4SG_Q65110A8252LB (LB_P4SG_Q65110A8252)
LED7	LB_P4SG_Q65110A8252LB	LB_P4SG_Q65110A8252	LB_P4SG_Q65110A8252LB (LB_P4SG_Q65110A8252)
LED8	LB_P4SG_Q65110A8252LB	LB_P4SG_Q65110A8252	LB_P4SG_Q65110A8252LB (LB_P4SG_Q65110A8252)
LED9	LEDCHIPLED_0603	0603	LED_0603D0603
PAD1	CAP_TOUCH_PAD	CAP_TOUCH_PAD	PROJECT7264_CC430_PAD
PAD2	CAP_TOUCH_PAD	CAP_TOUCH_PAD	PROJECT7264_CC430_PAD
PAD3	CAP_TOUCH_PAD	CAP_TOUCH_PAD	PROJECT7264_CC430_PAD
PAD4	CAP_TOUCH_PAD	CAP_TOUCH_PAD	PROJECT7264_CC430_PAD
PAD5	CAP_TOUCH_PAD	CAP_TOUCH_PAD	PROJECT7264_CC430_PAD
POT1	RV100F-30-4K1-B54	POT	Potentiometer 10mm Linear 50K PC Mount
Q1	MS1V-T1K 32.768kHz CL 12,5pF	Clock Crystal 32kHz SMT 2x2x6mm	F20XX_PIR_DEMO_ & EVAL_CM2 00T

Table 6. Bill of Materials (BOM) (continued)

Part	Value	Package Type	Device
Q2	SMD Oscillator 4MHz	SMD Oscillator 4MHz	QUARZ_HC49_4P-1
Q3	SMD Oscillator 12MHz	SMD Oscillator 12MHz	XTL_FT7AFT10A
R1	47k	0603	R-US_R0603
R2	0R	0603	R-US_R0603
R3	470R	0603	R-US_R0603
R4	470R	0603	R-US_R0603
R5	470R	0603	R-US_R0603
R6	47k	0603	R-US_R0603
R7	680	0805	RES0805
R8	680	0805	RES0805
R9	680	0805	RES0805
R10	680	0805	RES0805
R11	680	0805	RES0805
R12	100K	0603	R-US_R0603
R13	100k	0603	R-US_R0603
R14	100k	0603	R-US_R0603
R15	100K	0603	R-US_R0603
R16	100k	0603	R-US_R0603
R17	47k	0603	R-US_R0603
R18	47k	0603	R-US_R0603
R19	0	0603	R-US_R0603
R20	100k	0603	R-US_R0603
R21	36k 1%	0603	R-US_R0603
R22	27R	0603	R-US_R0603
R23	27R	0603	R-US_R0603
R24	1M	0603	R-US_R0603
R25	1k4	0603	R-US_R0603
R26	100R	0603	R-US_R0603
R27	33k	0603	R-US_R0603
R28	47k	0402	R_SMDR0402
R29	47k	0402	R_SMDR0402
R30	47k	0402	R_SMDR0402
R31	100R	0402	R_SMDR0402
R32	100R	0402	R_SMDR0402
R33	270	0402	R_SMDR0402
R34	DNP	0402	R_SMDR0402
R35	100R	0402	R_SMDR0402
R36	100R	0402	R_SMDR0402
R37	6k8	0402	R_SMDR0402
R38	3k3	0402	R_SMDR0402
R39	10k	0402	R_SMDR0402
R40	15k	0402	R_SMDR0402
R41	33k	0402	R_SMDR0402
R42	1k5	0402	R_SMDR0402
R43	33R	0402	R_SMDR0402
R44	DNP (47k)	0402	R_SMDR0402
R45	DNP (47k)	0402	R_SMDR0402

Table 6. Bill of Materials (BOM) (continued)

Part	Value	Package Type	Device
R46	33R	0402	R_SMDR0402
R47	100k/1%	0402	R_SMDR0402
R48	33k	0402	R_SMDR0402
R49	3k3	0402	R_SMDR0402
R50	100k/1%	0402	R_SMDR0402
R51	3k3	0402	R_SMDR0402
R52	100R	0402	R_SMDR0402
R53	1k5	0402	R_SMDR0402
R54	1k5	0402	R_SMDR0402
R58	0R	0603	R-US_R0603 (R-US_)
RF1	CCxxxx RF EVM HEADER	CCXXXX_20PIN	TFM-110-02-SM-D-A-K
RF2	CCxxxx RF EVM HEADER	CCXXXX_20PIN	TFM-110-02-SM-D-A-K
S1	USER1 PUSHBUTTON	BUTTON	EVQ-11L05R
S2	USER2 PUSHBUTTON	BUTTON	EVQ-11L05R
S3	F5529 RESET PUSHBUTTON	BUTTON	EVQ-11L05R
S4	F5529 USB BSL PUSHBUTTON	BUTTON	EVQ-11L05R
SW1	POWER SELECT SWITCH	DP3T_SWITCH	JS203011CQN
TP1	F5529 VREF+ TEST POINT	TEST_POINT	-
TP2	F5529 VCORE TEST POINT	TEST_POINT	-
TP3	CC430 EM TEST POINT	TEST_POINT	-
TP4	CC430 EM TEST POINT	TEST_POINT	-
TP5	CC430 EM TEST POINT	TEST_POINT	-
TP6	CC430 EM TEST POINT	TEST_POINT	-
TP7	CC430 EM TEST POINT	TEST_POINT	-
TP8	CC430 EM TEST POINT	TEST_POINT	-
TP9	eZ430 F16x TEST POINT (EZ_VBUS)	TEST_POINT	-
TP10	eZ430 F16x TEST POINT (RESET)	TEST_POINT	-
TP11	eZ430 F16x TEST POINT (GND)	TEST_POINT	-
TP12	eZ430 F16x TEST POINT (HTCK)	TEST_POINT	-
TP13	eZ430 F16x TEST POINT (HTMS)	TEST_POINT	-
TP14	eZ430 F16x TEST POINT (HTDI)	TEST_POINT	-
TP15	eZ430 F16x TEST POINT (HTDO)	TEST_POINT	-
U1	F5529 - MSP430F5529	80-LQFP	MSP430F5529IPNR
U2	LIS3DH	LGA16R50P3X5_300X300X100	LIS3DH
U3	102x64 LCD DISPLAY	EA DOGS102-6	EA DOGS102-6
U3	LED BACKLIGHT	EA DOGS102-6	EA LED39x41-W
U4	Alternate LDO - TPS73533	SC70-5	TPS73533DRBT
U5	LED Backlight Current Source - TPS75105	SON-10	TPS75105DSKR
U6	F5529 USB ESD Protection - TPD2E001	SOT-5	TPD2E001DRLR
U7	eZ430 - MSP430F16x	64-LQFP	MSP430F1612IPMR
U8	eZ430 Level Translator - TXS0104E	14-TSSOP	TXS0104EPWR
U9	eZ430 LDO - TPS77301	8-MSOP	TPS77301DGK
U10	eZ430 - TUSB3410	32-LQFP	TUSB3410VF
U11	eZ430 USB ESD Protection - TPD2E001	SOT-5	TPD2E001DRLR
U12	eZ430 EEPROM - CAT24C128YI	8-TSSOP	CAT24C128YI

Table 6. Bill of Materials (BOM) (continued)

Part	Value	Package Type	Device
USB1	F5529 USB	Mini-USB Through Hole	54819-0519
USB2	eZ430 USB	Mini-USB Through Hole	54819-0519
X1	microSD Card Holder	microSD Card Holder	502702-0891

Revision History

NOTE: Page numbers for previous revisions may differ from page numbers in the current version.

Changes from July 1, 2011 to April 7, 2017

Page

-
- Removed the *FCC Warning* section; see the important notice at the end of this document 4
 - Updated all figures in [Section 5.3, Schematics and BOM](#)..... 22
 - Updated [Table 6, Bill of Materials](#) 30
-

IMPORTANT NOTICE FOR TI DESIGN INFORMATION AND RESOURCES

Texas Instruments Incorporated ("TI") technical, application or other design advice, services or information, including, but not limited to, reference designs and materials relating to evaluation modules, (collectively, "TI Resources") are intended to assist designers who are developing applications that incorporate TI products; by downloading, accessing or using any particular TI Resource in any way, you (individually or, if you are acting on behalf of a company, your company) agree to use it solely for this purpose and subject to the terms of this Notice.

TI's provision of TI Resources does not expand or otherwise alter TI's applicable published warranties or warranty disclaimers for TI products, and no additional obligations or liabilities arise from TI providing such TI Resources. TI reserves the right to make corrections, enhancements, improvements and other changes to its TI Resources.

You understand and agree that you remain responsible for using your independent analysis, evaluation and judgment in designing your applications and that you have full and exclusive responsibility to assure the safety of your applications and compliance of your applications (and of all TI products used in or for your applications) with all applicable regulations, laws and other applicable requirements. You represent that, with respect to your applications, you have all the necessary expertise to create and implement safeguards that (1) anticipate dangerous consequences of failures, (2) monitor failures and their consequences, and (3) lessen the likelihood of failures that might cause harm and take appropriate actions. You agree that prior to using or distributing any applications that include TI products, you will thoroughly test such applications and the functionality of such TI products as used in such applications. TI has not conducted any testing other than that specifically described in the published documentation for a particular TI Resource.

You are authorized to use, copy and modify any individual TI Resource only in connection with the development of applications that include the TI product(s) identified in such TI Resource. NO OTHER LICENSE, EXPRESS OR IMPLIED, BY ESTOPPEL OR OTHERWISE TO ANY OTHER TI INTELLECTUAL PROPERTY RIGHT, AND NO LICENSE TO ANY TECHNOLOGY OR INTELLECTUAL PROPERTY RIGHT OF TI OR ANY THIRD PARTY IS GRANTED HEREIN, including but not limited to any patent right, copyright, mask work right, or other intellectual property right relating to any combination, machine, or process in which TI products or services are used. Information regarding or referencing third-party products or services does not constitute a license to use such products or services, or a warranty or endorsement thereof. Use of TI Resources may require a license from a third party under the patents or other intellectual property of the third party, or a license from TI under the patents or other intellectual property of TI.

TI RESOURCES ARE PROVIDED "AS IS" AND WITH ALL FAULTS. TI DISCLAIMS ALL OTHER WARRANTIES OR REPRESENTATIONS, EXPRESS OR IMPLIED, REGARDING TI RESOURCES OR USE THEREOF, INCLUDING BUT NOT LIMITED TO ACCURACY OR COMPLETENESS, TITLE, ANY EPIDEMIC FAILURE WARRANTY AND ANY IMPLIED WARRANTIES OF MERCHANTABILITY, FITNESS FOR A PARTICULAR PURPOSE, AND NON-INFRINGEMENT OF ANY THIRD PARTY INTELLECTUAL PROPERTY RIGHTS.

TI SHALL NOT BE LIABLE FOR AND SHALL NOT DEFEND OR INDEMNIFY YOU AGAINST ANY CLAIM, INCLUDING BUT NOT LIMITED TO ANY INFRINGEMENT CLAIM THAT RELATES TO OR IS BASED ON ANY COMBINATION OF PRODUCTS EVEN IF DESCRIBED IN TI RESOURCES OR OTHERWISE. IN NO EVENT SHALL TI BE LIABLE FOR ANY ACTUAL, DIRECT, SPECIAL, COLLATERAL, INDIRECT, PUNITIVE, INCIDENTAL, CONSEQUENTIAL OR EXEMPLARY DAMAGES IN CONNECTION WITH OR ARISING OUT OF TI RESOURCES OR USE THEREOF, AND REGARDLESS OF WHETHER TI HAS BEEN ADVISED OF THE POSSIBILITY OF SUCH DAMAGES.

You agree to fully indemnify TI and its representatives against any damages, costs, losses, and/or liabilities arising out of your non-compliance with the terms and provisions of this Notice.

This Notice applies to TI Resources. Additional terms apply to the use and purchase of certain types of materials, TI products and services. These include; without limitation, TI's standard terms for semiconductor products (<http://www.ti.com/sc/docs/stdterms.htm>), [evaluation modules](#), and [samples](http://www.ti.com/sc/docs/sampterm.htm) (<http://www.ti.com/sc/docs/sampterm.htm>).

Mailing Address: Texas Instruments, Post Office Box 655303, Dallas, Texas 75265
Copyright © 2018, Texas Instruments Incorporated

Looking for pricing, stock, or lifecycle information?

Click below to explore more details on WIN SOURCE:

 [View TL431ACDG4](#) on WIN SOURCE

 [Texas Instruments](#) Information

Optimize Your Supply Chain with WIN SOURCE Solutions

-  Global Sourcing Solution
-  Obsolete Management
-  Cost Control Management
-  Shortage Management
-  Alternative Solution
-  Excess Inventory Management