



**THE DATASHEET OF  
TLC59212IPWR**



## TLC59212 8-Bit Open-Collector Sink Driver with Latch

### 1 Features

- LBC3S (Lin BiCMOS) Process
- High Voltage Output ( $V_{OUT} = 24\text{ V}$ )
- Output Current ( $I_{OL}$  Maximum = 40 mA)
- Latch-Up Performance Exceeds 250 mA Per JEDEC Standard JESD-17
- ESD Protection Exceeds JESD 22
  - 2000-V Human Body Model (A114-A)
  - 200-V Machine Model (A115-A)
  - 1000-V Charged Device Model (C101)

### 2 Applications

- Lamps and Displays (LED)
- Hammers
- Relay

### 3 Description

The TLC59212 device is an 8-bit open-collector driver with latch designed for 5-V  $V_{CC}$  operation.

These circuits are positive-edge-triggered D-type flip-flops with a direct clear (CLR) input. Information at the data (D) input meeting the setup time requirements is transferred to the  $\bar{Y}$  output on the positive-going edge of the clock (CLK) pulse. Clock triggering occurs at a particular voltage level and is not directly related to the transition time of the positive-going pulse. When CLK is at either the high or low level, the D-input has no effect at the output.

The TLC59212 is characterized for operation from  $-40^{\circ}\text{C}$  to  $85^{\circ}\text{C}$ .

#### Device Information<sup>(1)</sup>

PART NUMBER	PACKAGE	BODY SIZE (NOM)
TLC59212	PDIP (20)	24.33 mm x 6.35 mm
	TSSOP (20)	6.50 mm x 4.40 mm

(1) For all available packages, see the orderable addendum at the end of the data sheet.

#### Typical Application Diagram

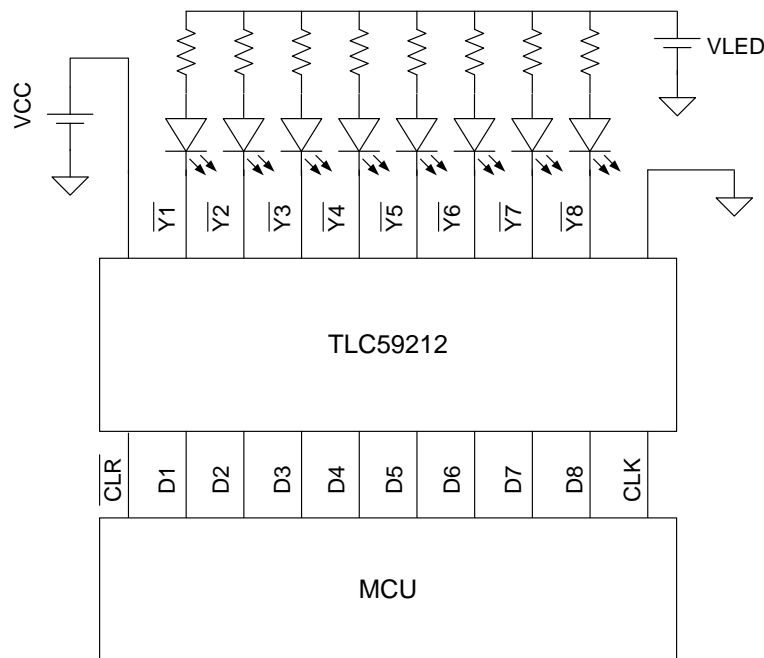

## Table of Contents

<b>1 Features</b> ..... 1 <b>2 Applications</b> ..... 1 <b>3 Description</b> ..... 1 <b>4 Revision History</b> ..... 2 <b>5 Pin Configuration and Functions</b> ..... 3 <b>6 Specifications</b> ..... 4 6.1 Absolute Maximum Ratings ..... 4 6.2 ESD Ratings ..... 4 6.3 Recommended Operating Conditions ..... 4 6.4 Thermal Information ..... 4 6.5 Electrical Characteristics ..... 5 6.6 Timing Requirements ..... 5 6.7 Switching Characteristics ..... 5 6.8 Typical Characteristics ..... 6 <b>7 Parameter Measurement Information</b> ..... 7 <b>8 Detailed Description</b> ..... 8 8.1 Overview ..... 8	8.2 Functional Block Diagram ..... 8 8.3 Feature Description ..... 8 8.4 Device Functional Modes ..... 8 <b>9 Application and Implementation</b> ..... 9 9.1 Application Information ..... 9 9.2 Typical Application ..... 9 <b>10 Power Supply Recommendations</b> ..... 10 <b>11 Layout</b> ..... 11 11.1 Layout Guidelines ..... 11 11.2 Layout Example ..... 11 <b>12 Device and Documentation Support</b> ..... 12 12.1 Community Resources ..... 12 12.2 Trademarks ..... 12 12.3 Electrostatic Discharge Caution ..... 12 12.4 Glossary ..... 12 <b>13 Mechanical, Packaging, and Orderable Information</b> ..... 12
--	--

## 4 Revision History

NOTE: Page numbers for previous revisions may differ from page numbers in the current version.

Changes from Original (March 2009) to Revision A	Page
<ul style="list-style-type: none"> <li>• Added <i>ESD Ratings</i> table, <i>Feature Description</i> section, <i>Device Functional Modes</i>, <i>Application and Implementation</i> section, <i>Power Supply Recommendations</i> section, <i>Layout</i> section, <i>Device and Documentation Support</i> section, and <i>Mechanical, Packaging, and Orderable Information</i> section. ....</li> </ul>	1

## 5 Pin Configuration and Functions

**N or PW Package  
20-Pin PDIP or TSSOP  
Top View**

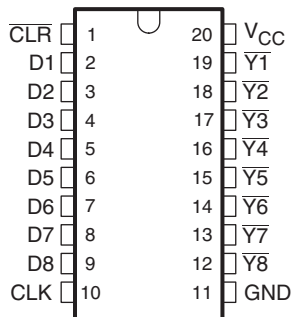

**Pin Functions**

PIN		I/O	DESCRIPTION
NAME	NO.		
$\overline{\text{CLR}}$	1	I	Direct clear of output
D1	2	I	Input control to the current sink driver
D2	3	I	Input control to the current sink driver
D3	4	I	Input control to the current sink driver
D4	5	I	Input control to the current sink driver
D5	6	I	Input control to the current sink driver
D6	7	I	Input control to the current sink driver
D7	8	I	Input control to the current sink driver
D8	9	I	Input control to the current sink driver
CLK	10	I	Clock to positive edge triggered D flipflops
GND	11	—	Ground
$\overline{\text{Y8}}$	12	O	Output to load
$\overline{\text{Y7}}$	13	O	Output to load
$\overline{\text{Y6}}$	14	O	Output to load
$\overline{\text{Y5}}$	15	O	Output to load
$\overline{\text{Y4}}$	16	O	Output to load
$\overline{\text{Y3}}$	17	O	Output to load
$\overline{\text{Y2}}$	18	O	Output to load
$\overline{\text{Y1}}$	19	O	Output to load
$V_{\text{CC}}$	20	I	Supply voltage

## 6 Specifications

### 6.1 Absolute Maximum Ratings

 over operating free-air temperature range (unless otherwise noted)<sup>(1)</sup>

		MIN	MAX	UNIT
V <sub>CC</sub>	Supply voltage	-0.5	7	V
D	Input voltage	D, CLK, $\overline{\text{CLR}}$		V
V <sub>O</sub>	Output voltage	H output		V
I <sub>O</sub>	Output current	1 bit for output low		mA
I <sub>IK</sub>	Input clamp current	V <sub>I</sub> < 0 V		mA
T <sub>A</sub>	Operating free-air temperature	-40	85	°C
T <sub>stg</sub>	Storage temperature	-65	150	°C

- (1) Stresses beyond those listed under *Absolute Maximum Ratings* may cause permanent damage to the device. These are stress ratings only, which do not imply functional operation of the device at these or any other conditions beyond those indicated under *Recommended Operating Conditions*. Exposure to absolute-maximum-rated conditions for extended periods may affect device reliability.

### 6.2 ESD Ratings

		VALUE	UNIT
V <sub>(ESD)</sub>	Electrostatic discharge	Human body model (HBM), per ANSI/ESDA/JEDEC JS-001 <sup>(1)</sup>	±2000
		Charged-device model (CDM), per JEDEC specification JESD22-C101 <sup>(2)</sup>	±1000

- (1) JEDEC document JEP155 states that 500-V HBM allows safe manufacturing with a standard ESD control process.

- (2) JEDEC document JEP157 states that 250-V CDM allows safe manufacturing with a standard ESD control process.

### 6.3 Recommended Operating Conditions

 V<sub>CC</sub> = 4.5 V to 5.5 V. Over operating free-air temperature range (unless otherwise noted)

		MIN	MAX	UNIT
V <sub>CC</sub>	Supply voltage	4.5	5.5	V
V <sub>IH</sub>	High-level input voltage	V <sub>CC</sub> × 0.7	V <sub>CC</sub>	V
V <sub>IL</sub>	Low-level input voltage	0	V <sub>CC</sub> × 0.3	V
V <sub>O</sub>	Output voltage	0	24	V
I <sub>O</sub>	Output current, Duty cycle < 100%	0	40	mA
T <sub>A</sub>	Operating free-air temperature	-40	85	°C

### 6.4 Thermal Information

THERMAL METRIC <sup>(1)</sup>	TLC59212		UNIT	
	N (PDIP)	PW (TSSOP)		
	20 PINS	20 PINS		
R <sub>θJA</sub>	Junction-to-ambient thermal resistance	55.8	96.0	°C/W
R <sub>θJC(top)</sub>	Junction-to-case (top) thermal resistance	47.4	29.8	°C/W
R <sub>θJB</sub>	Junction-to-board thermal resistance	36.8	47.3	°C/W
ψ <sub>JT</sub>	Junction-to-top characterization parameter	24.3	1.8	°C/W
ψ <sub>JB</sub>	Junction-to-board characterization parameter	36.6	46.7	°C/W
R <sub>θJC(bot)</sub>	Junction-to-case (bottom) thermal resistance	—	—	°C/W

- (1) For more information about traditional and new thermal metrics, see the *Semiconductor and IC Package Thermal Metrics* application report, [SPRA953](#).

## 6.5 Electrical Characteristics

over operating free-air temperature range (unless otherwise noted)

PARAMETER		TEST CONDITIONS	MIN	TYP	MAX	UNIT	
$V_{t+}$	Positive-going input threshold	D, $\overline{\text{CLR}}$ , CLK			3.5	V	
$V_{t-}$	Negative-going input threshold	D, $\overline{\text{CLR}}$ , CLK	1.5			V	
$V_t$	Hysteresis	D, $\overline{\text{CLR}}$ , CLK	0.5		2	V	
$V_{O(\text{off})}$	Output tr sustain voltage	$I_{ce} = 1 \text{ mA}$	24			V	
$I_{OZ}$	Output tr leakage current	$V_O = 24 \text{ V}$		0	5	$\mu\text{A}$	
$I_{IH}$	High-level input current	$V_{CC} = 5.5 \text{ V}$ , $V_I = 5.5 \text{ V}$		0	1	$\mu\text{A}$	
$I_{IL}$	Low-level input current	$V_{CC} = 5.5 \text{ V}$ , $V_I = 0 \text{ V}$		0	-1	$\mu\text{A}$	
$I_{\text{off}}$	Leakage current	$V_I = 0 \text{ to } 5 \text{ V}$ , $V_O = 0 \text{ to } 30 \text{ V}$ , $V_{CC} = 0$		0	5	$\mu\text{A}$	
$I_{CC}$	Supply current	$V_I = 0 \text{ to } 5 \text{ V}$ , $V_O = 0 \text{ to } 30 \text{ V}$ , $V_{CC} = 0$	Output = all OFF		0	5	$\mu\text{A}$
			Output = all ON		8	20	
$V_{OL}$	Low-level output voltage	$V_{CC} = 4.5 \text{ V}$ , $I_O = 40 \text{ mA}$		0.32	0.55	V	
$r_{ON}$	ON-state resistance	$V_{CC} = 4.5 \text{ V}$ , $I_O = 10 \text{ mA}$		8	13	$\Omega$	
$C_i$	Input capacitance	$V_I = V_{CC} \text{ or } \text{GND}$		5		pF	

## 6.6 Timing Requirements

over  $T_A = -40^\circ\text{C}$  to  $85^\circ\text{C}$ ,  $V_{CC} = 4.5 \text{ V}$  to  $5.5 \text{ V}$ , O/C to Y (unless otherwise noted)

				MIN	MAX	UNIT
$t_{su}$	Setup time	CLK	$V_{DD} = 4.5 \text{ V to } 5.5 \text{ V}$	5		ns
$t_h$	Hold time	CLK	$V_{DD} = 4.5 \text{ V to } 5.5 \text{ V}$	15		ns
$t_w$	Pulse width	CLK, $\overline{\text{CLR}}$	$V_{DD} = 4.5 \text{ V to } 5.5 \text{ V}$	20		ns

## 6.7 Switching Characteristics

over operating free-air temperature range (unless otherwise noted), see [Figure 2](#)

PARAMETER	TEST CONDITIONS	LOAD CAPACITANCE	$T_A = 25^\circ\text{C}$			$T_A = -40^\circ\text{C to } 85^\circ\text{C}$		UNIT
			MIN	TYP	MAX	MIN	MAX	
$t_{TLH}$	Output = low to high	$C_L = 50 \text{ pF}$ , $R_L = 500 \Omega$		60	185		185	ns
$t_{THL}$	Output = high to low	$C_L = 50 \text{ pF}$ , $R_L = 500 \Omega$		10	185		185	ns
$t_{PLH}$	Output = low to high	$C_L = 50 \text{ pF}$ , $R_L = 500 \Omega$		70	210		250	ns
$t_{PHL}$	Output = high to low	$C_L = 50 \text{ pF}$ , $R_L = 500 \Omega$		45	210		250	ns
$t_{PHLR}$	$\overline{\text{CLR}}\text{-}\overline{\text{Y}}$	$C_L = 50 \text{ pF}$ , $R_L = 500 \Omega$		70	210		250	ns

## 6.8 Typical Characteristics

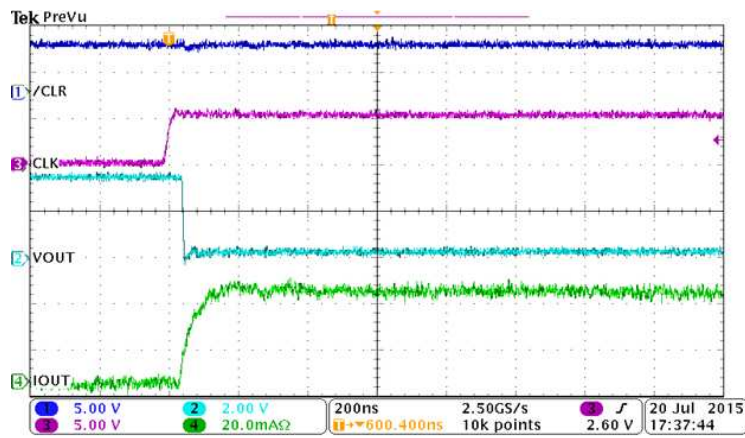

**Figure 1. Output Voltage and Current Response**

## 7 Parameter Measurement Information

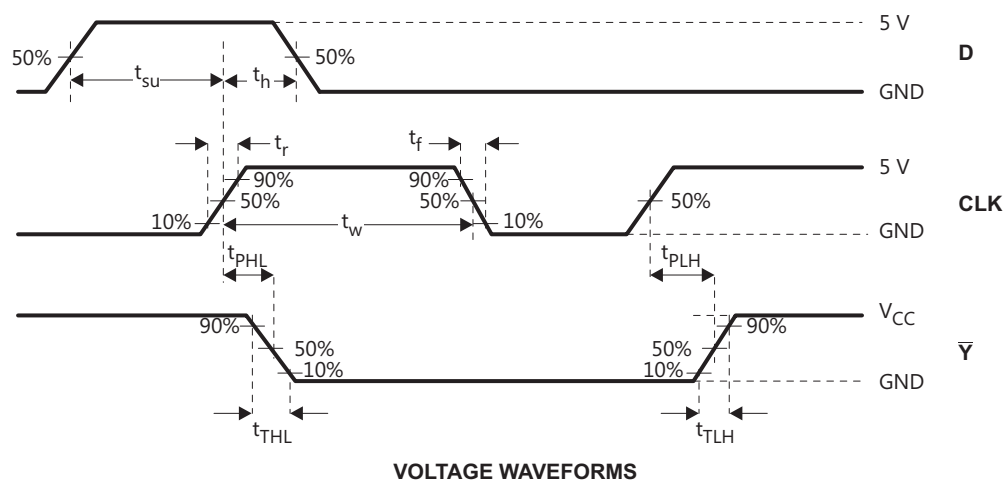
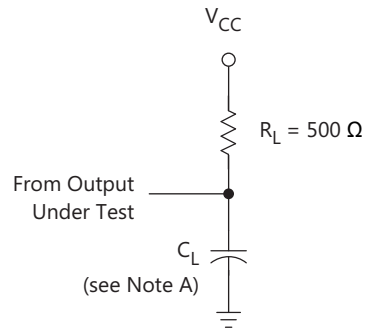

- A.  $C_L$  includes probe and jig capacitance.
- B. All input pulses are supplied by generators having the following characteristics:  $PRR \leq 1$  MHz,  $Z_O = 50 \Omega$ ,  $t_r \leq 3$  ns, and  $t_f \leq 3$  ns.
- C. The outputs are measured one at a time with one transition per measurement.
- D.  $t_{PLH}$  and  $t_{PHL}$  are the same as  $t_{pd}$ .

**Figure 2. Test Circuit and Voltage Waveforms**

## 8 Detailed Description

### 8.1 Overview

The TLC59212 device is an 8-bit open-collector driver with latch designed for 5-V  $V_{CC}$  operation.

### 8.2 Functional Block Diagram

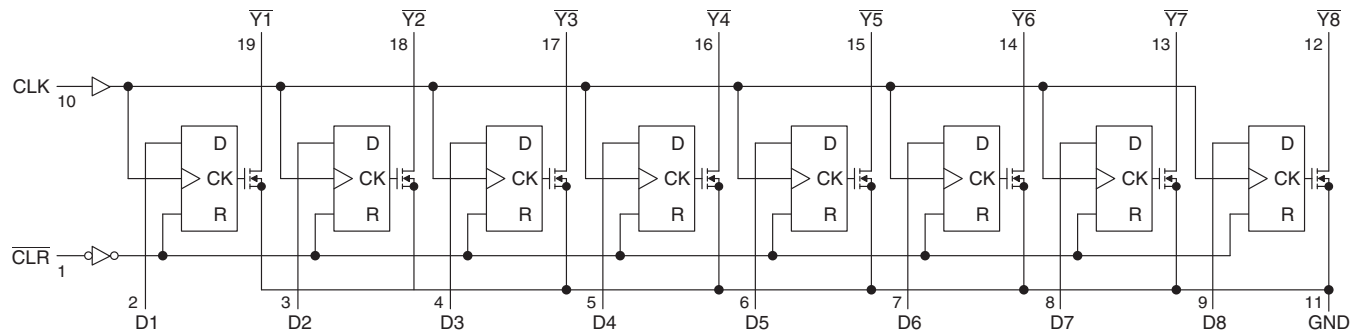

(1) This symbol is in accordance with ANSI/IEEE Standard 91-1984 and IEC Publication 617-12.

**Figure 3. Logic Symbol**

### 8.3 Feature Description

Each of the 8 channels is controlled by its input ( $D_n$ ), a direct clear ( $\overline{CLR}$ ), and clock (CLK) through a positive-edge-triggered D-type flip-flops. Information at the data (D) input meeting the setup time requirements is transferred to the output (Y) on the positive-going edge of the clock (CLK) pulse. When CLK is at either the high or low level, the D-input has no effect at the output. When  $\overline{CLR}$  is at low level, the D-input has no effect at the output.

### 8.4 Device Functional Modes

Table 1 lists the functional modes of the TLC59212.

**Table 1. Function Table (Each Latch)<sup>(1)</sup>**

INPUTS			OUTPUT $\overline{Y}$
$\overline{CLR}$	CLK	D	
L	X	X	H*
H	↑	L	H*
H	↑	H	L
H	L	X	$Y_0$
H	↓	X	$Y_0$

(1) L: Low-level  
 H: High-level  
 H\*: with pullup resistor  
 X: Irrelevant  
 ↑: Rising edge  
 ↓: Falling edge  
 Z: High-impedance (OFF)

## 9 Application and Implementation

### NOTE

Information in the following applications sections is not part of the TI component specification, and TI does not warrant its accuracy or completeness. TI's customers are responsible for determining suitability of components for their purposes. Customers should validate and test their design implementation to confirm system functionality.

### 9.1 Application Information

In LED display application, TLC59212 is used to drive the current sink for 8 LEDs in parallel. LED display pattern can be created by providing different bit pattern. At every positive clock edge, new bit pattern will be transferred to LED display.

### 9.2 Typical Application

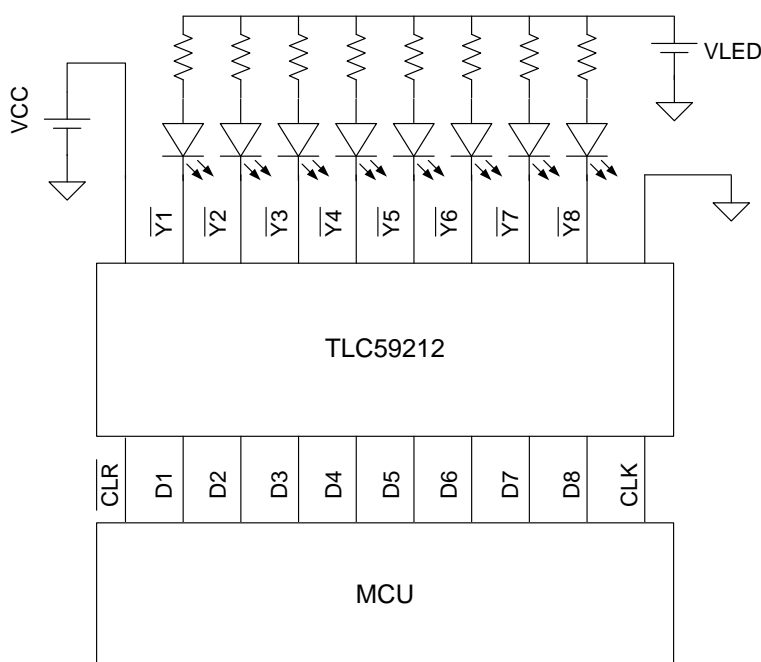

Figure 4. Typical Application Diagram

#### 9.2.1 Design Requirements

For LED display application, LED is selected based on the application. The current level is determined by the required brightness. Given the available LED supply, the resistor value could be determined. The TLC59212 has a maximum current requirement less than 40mA for constant on application.

#### 9.2.2 Detailed Design Procedure

The selection of supply voltage (VLED), LED, and resistor sets the current of the LED.

$$V_R + V_L + V_{OL} = V_{LED} \tag{1}$$

$$I = (V_{LED} - V_L - V_{OL}) / R \tag{2}$$

$V_R$  is the voltage drop across the resistor,  $V_L$  is the voltage drop across the LED when LED is on,  $V_{OL}$  is the output voltage at the collector when the driver is enabled. For example, when  $V_{LED} = 5\text{ V}$ ,  $V_L = 2.4\text{ V}$ , and  $V_{OL} = 0.35\text{ V}$ , a  $55\text{-}\Omega$  resistor is used to obtain output current 40 mA.

## Typical Application (continued)

### 9.2.3 Application Curve

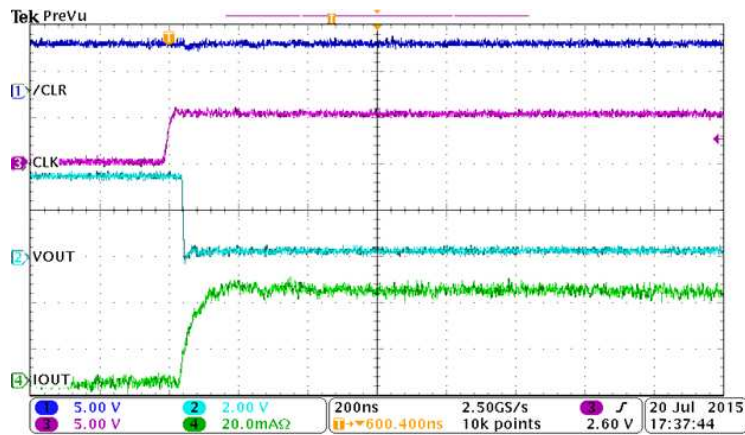

Figure 5. Output Voltage and Current Response

## 10 Power Supply Recommendations

The supply voltage to TLC59212 is from 4.5 V to 5.5 V. The voltage at output can be up to 24 V.

## 11 Layout

### 11.1 Layout Guidelines

The traces that carry current from the LED cathodes to the output pins must be wide enough to support the current (up to 40 mA).

### 11.2 Layout Example

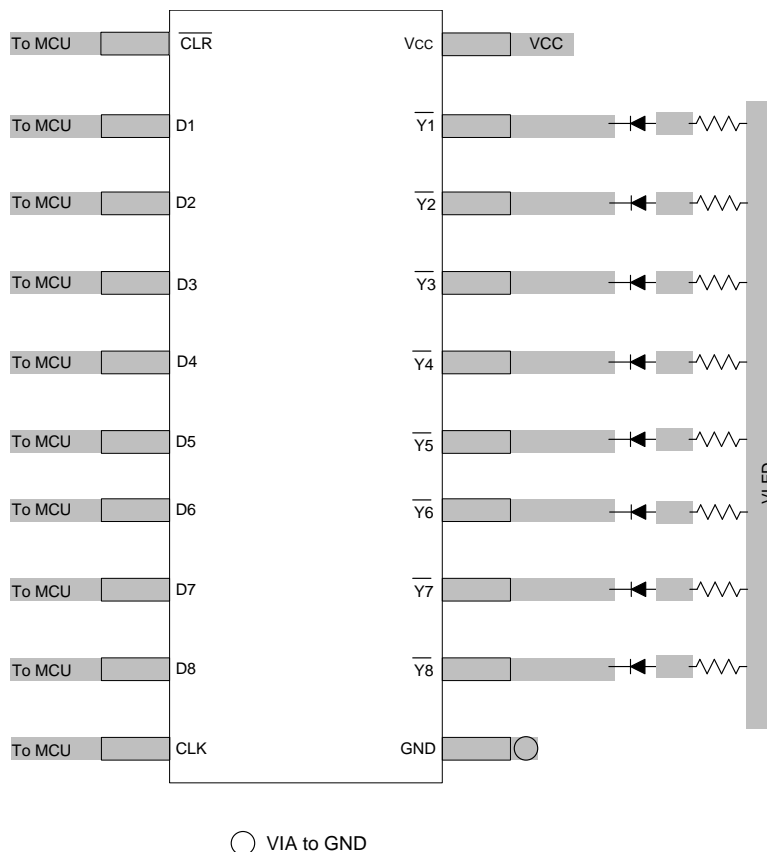

**Figure 6. Layout Recommendation**

## 12 Device and Documentation Support

### 12.1 Community Resources

The following links connect to TI community resources. Linked contents are provided "AS IS" by the respective contributors. They do not constitute TI specifications and do not necessarily reflect TI's views; see TI's [Terms of Use](#).

**TI E2E™ Online Community** *TI's Engineer-to-Engineer (E2E) Community*. Created to foster collaboration among engineers. At [e2e.ti.com](http://e2e.ti.com), you can ask questions, share knowledge, explore ideas and help solve problems with fellow engineers.

**Design Support** *TI's Design Support* Quickly find helpful E2E forums along with design support tools and contact information for technical support.

### 12.2 Trademarks

E2E is a trademark of Texas Instruments.  
All other trademarks are the property of their respective owners.

### 12.3 Electrostatic Discharge Caution



These devices have limited built-in ESD protection. The leads should be shorted together or the device placed in conductive foam during storage or handling to prevent electrostatic damage to the MOS gates.

### 12.4 Glossary

[SLYZ022](#) — *TI Glossary*.

This glossary lists and explains terms, acronyms, and definitions.

## 13 Mechanical, Packaging, and Orderable Information

The following pages include mechanical, packaging, and orderable information. This information is the most current data available for the designated devices. This data is subject to change without notice and revision of this document. For browser-based versions of this data sheet, refer to the left-hand navigation.

**PACKAGING INFORMATION**

Orderable Device	Status (1)	Package Type	Package Drawing	Pins	Package Qty	Eco Plan (2)	Lead finish/ Ball material (6)	MSL Peak Temp (3)	Op Temp (°C)	Device Marking (4/5)	Samples
TLC59212IPWR	ACTIVE	TSSOP	PW	20	2000	RoHS & Green	NIPDAU	Level-1-260C-UNLIM	-40 to 85	Y59212	<b>Samples</b>

(1) The marketing status values are defined as follows:

**ACTIVE:** Product device recommended for new designs.

**LIFEBUY:** TI has announced that the device will be discontinued, and a lifetime-buy period is in effect.

**NRND:** Not recommended for new designs. Device is in production to support existing customers, but TI does not recommend using this part in a new design.

**PREVIEW:** Device has been announced but is not in production. Samples may or may not be available.

**OBSOLETE:** TI has discontinued the production of the device.

(2) **RoHS:** TI defines "RoHS" to mean semiconductor products that are compliant with the current EU RoHS requirements for all 10 RoHS substances, including the requirement that RoHS substance do not exceed 0.1% by weight in homogeneous materials. Where designed to be soldered at high temperatures, "RoHS" products are suitable for use in specified lead-free processes. TI may reference these types of products as "Pb-Free".

**RoHS Exempt:** TI defines "RoHS Exempt" to mean products that contain lead but are compliant with EU RoHS pursuant to a specific EU RoHS exemption.

**Green:** TI defines "Green" to mean the content of Chlorine (Cl) and Bromine (Br) based flame retardants meet JS709B low halogen requirements of <=1000ppm threshold. Antimony trioxide based flame retardants must also meet the <=1000ppm threshold requirement.

(3) MSL, Peak Temp. - The Moisture Sensitivity Level rating according to the JEDEC industry standard classifications, and peak solder temperature.

(4) There may be additional marking, which relates to the logo, the lot trace code information, or the environmental category on the device.

(5) Multiple Device Markings will be inside parentheses. Only one Device Marking contained in parentheses and separated by a "-" will appear on a device. If a line is indented then it is a continuation of the previous line and the two combined represent the entire Device Marking for that device.

(6) Lead finish/Ball material - Orderable Devices may have multiple material finish options. Finish options are separated by a vertical ruled line. Lead finish/Ball material values may wrap to two lines if the finish value exceeds the maximum column width.

**Important Information and Disclaimer:** The information provided on this page represents TI's knowledge and belief as of the date that it is provided. TI bases its knowledge and belief on information provided by third parties, and makes no representation or warranty as to the accuracy of such information. Efforts are underway to better integrate information from third parties. TI has taken and continues to take reasonable steps to provide representative and accurate information but may not have conducted destructive testing or chemical analysis on incoming materials and chemicals. TI and TI suppliers consider certain information to be proprietary, and thus CAS numbers and other limited information may not be available for release.

In no event shall TI's liability arising out of such information exceed the total purchase price of the TI part(s) at issue in this document sold by TI to Customer on an annual basis.

**TAPE AND REEL INFORMATION**

**QUADRANT ASSIGNMENTS FOR PIN 1 ORIENTATION IN TAPE**

\*All dimensions are nominal

Device	Package Type	Package Drawing	Pins	SPQ	Reel Diameter (mm)	Reel Width W1 (mm)	A0 (mm)	B0 (mm)	K0 (mm)	P1 (mm)	W (mm)	Pin1 Quadrant
TLC59212IPWR	TSSOP	PW	20	2000	330.0	16.4	6.95	7.0	1.4	8.0	16.0	Q1

**TAPE AND REEL BOX DIMENSIONS**

\*All dimensions are nominal

Device	Package Type	Package Drawing	Pins	SPQ	Length (mm)	Width (mm)	Height (mm)
TLC59212IPWR	TSSOP	PW	20	2000	356.0	356.0	35.0

# PW0020A



# PACKAGE OUTLINE

## TSSOP - 1.2 mm max height

SMALL OUTLINE PACKAGE



4220206/A 02/2017

### NOTES:

1. All linear dimensions are in millimeters. Any dimensions in parenthesis are for reference only. Dimensioning and tolerancing per ASME Y14.5M.
2. This drawing is subject to change without notice.
3. This dimension does not include mold flash, protrusions, or gate burrs. Mold flash, protrusions, or gate burrs shall not exceed 0.15 mm per side.
4. This dimension does not include interlead flash. Interlead flash shall not exceed 0.25 mm per side.
5. Reference JEDEC registration MO-153.

# EXAMPLE BOARD LAYOUT

PW0020A

TSSOP - 1.2 mm max height

SMALL OUTLINE PACKAGE



LAND PATTERN EXAMPLE  
EXPOSED METAL SHOWN  
SCALE: 10X



SOLDER MASK DETAILS

4220206/A 02/2017

NOTES: (continued)

- 6. Publication IPC-7351 may have alternate designs.
- 7. Solder mask tolerances between and around signal pads can vary based on board fabrication site.

# EXAMPLE STENCIL DESIGN

PW0020A

TSSOP - 1.2 mm max height

SMALL OUTLINE PACKAGE



SOLDER PASTE EXAMPLE  
BASED ON 0.125 mm THICK STENCIL  
SCALE: 10X

4220206/A 02/2017

NOTES: (continued)

8. Laser cutting apertures with trapezoidal walls and rounded corners may offer better paste release. IPC-7525 may have alternate design recommendations.
9. Board assembly site may have different recommendations for stencil design.

PW (R-PDSO-G20)

PLASTIC SMALL OUTLINE



- NOTES:
- A. All linear dimensions are in millimeters.
  - B. This drawing is subject to change without notice.
  - C. Publication IPC-7351 is recommended for alternate design.
  - D. Laser cutting apertures with trapezoidal walls and also rounding corners will offer better paste release. Customers should contact their board assembly site for stencil design recommendations. Refer to IPC-7525 for other stencil recommendations.
  - E. Customers should contact their board fabrication site for solder mask tolerances between and around signal pads.

## IMPORTANT NOTICE AND DISCLAIMER

TI PROVIDES TECHNICAL AND RELIABILITY DATA (INCLUDING DATA SHEETS), DESIGN RESOURCES (INCLUDING REFERENCE DESIGNS), APPLICATION OR OTHER DESIGN ADVICE, WEB TOOLS, SAFETY INFORMATION, AND OTHER RESOURCES "AS IS" AND WITH ALL FAULTS, AND DISCLAIMS ALL WARRANTIES, EXPRESS AND IMPLIED, INCLUDING WITHOUT LIMITATION ANY IMPLIED WARRANTIES OF MERCHANTABILITY, FITNESS FOR A PARTICULAR PURPOSE OR NON-INFRINGEMENT OF THIRD PARTY INTELLECTUAL PROPERTY RIGHTS.

These resources are intended for skilled developers designing with TI products. You are solely responsible for (1) selecting the appropriate TI products for your application, (2) designing, validating and testing your application, and (3) ensuring your application meets applicable standards, and any other safety, security, regulatory or other requirements.

These resources are subject to change without notice. TI grants you permission to use these resources only for development of an application that uses the TI products described in the resource. Other reproduction and display of these resources is prohibited. No license is granted to any other TI intellectual property right or to any third party intellectual property right. TI disclaims responsibility for, and you will fully indemnify TI and its representatives against, any claims, damages, costs, losses, and liabilities arising out of your use of these resources.

TI's products are provided subject to [TI's Terms of Sale](#) or other applicable terms available either on [ti.com](http://ti.com) or provided in conjunction with such TI products. TI's provision of these resources does not expand or otherwise alter TI's applicable warranties or warranty disclaimers for TI products.

TI objects to and rejects any additional or different terms you may have proposed.

Mailing Address: Texas Instruments, Post Office Box 655303, Dallas, Texas 75265  
Copyright © 2022, Texas Instruments Incorporated

## Looking for pricing, stock, or lifecycle information?

Click below to explore more details on WIN SOURCE:

 [View TLC59212IPWR on WIN SOURCE](#)

 [Texas Instruments](#) Information

## Optimize Your Supply Chain with WIN SOURCE Solutions

-  Global Sourcing Solution
-  Obsolete Management
-  Cost Control Management
-  Shortage Management
-  Alternative Solution
-  Excess Inventory Management