

FEATURES

- 55°C to +125°C (–67°F to +257°F) operation
- ±1.0°C accuracy over temperature (typ)
- Temperature-proportional voltage output
- User-programmable temperature trip points
- User-programmable hysteresis
- 20 mA open-collector trip point outputs
- TTL/CMOS compatible
- Single-supply operation (4.5 V to 13.2 V)
- PDIP, SOIC, and TO-99 packages

APPLICATIONS

- Over/under temperature sensor and alarm
- Board-level temperature sensing
- Temperature controllers
- Electronic thermostats
- Thermal protection
- HVAC systems
- Industrial process control
- Remote sensors

GENERAL DESCRIPTION

The TMP01 is a temperature sensor that generates a voltage output proportional to absolute temperature and a control signal from one of two outputs when the device is either above or below a specific temperature range. Both the high/low temperature trip points and hysteresis (overshoot) band are determined by user-selected external resistors. For high volume production, these resistors are available on board.

The TMP01 consists of a band gap voltage reference combined with a pair of matched comparators. The reference provides both a constant 2.5 V output and a voltage proportional to absolute temperature (VPTAT) which has a precise temperature coefficient of 5 mV/K and is 1.49 V (nominal) at 25°C. The comparators compare VPTAT with the externally set temperature trip points and generate an open-collector output signal when one of their respective thresholds has been exceeded.

FUNCTIONAL BLOCK DIAGRAM

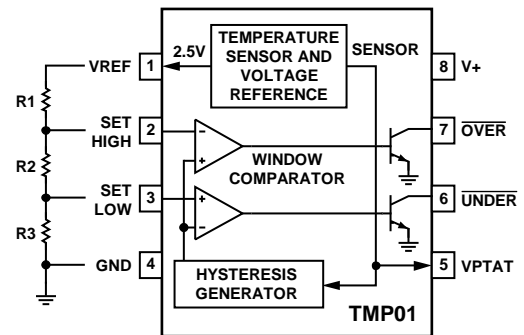

Figure 1.

Hysteresis is also programmed by the external resistor chain and is determined by the total current drawn out of the 2.5 V reference. This current is mirrored and used to generate a hysteresis offset voltage of the appropriate polarity after a comparator has been tripped. The comparators are connected in parallel, which guarantees that there is no hysteresis overlap and eliminates erratic transitions between adjacent trip zones.

The TMP01 utilizes proprietary thin-film resistors in conjunction with production laser trimming to maintain a temperature accuracy of ±1°C (typical) over the rated temperature range, with excellent linearity. The open-collector outputs are capable of sinking 20 mA, enabling the TMP01 to drive control relays directly. Operating from a 5 V supply, quiescent current is only 500 μA (max).

The TMP01 is available in 8-pin mini PDIP, SOIC, and TO-99 packages.

Rev. E

Information furnished by Analog Devices is believed to be accurate and reliable. However, no responsibility is assumed by Analog Devices for its use, nor for any infringements of patents or other rights of third parties that may result from its use. Specifications subject to change without notice. No license is granted by implication or otherwise under any patent or patent rights of Analog Devices. Trademarks and registered trademarks are the property of their respective owners.

TABLE OF CONTENTS

Features	1	Self-Heating Effects.....	10
Applications.....	1	Buffering the Voltage Reference.....	10
Functional Block Diagram	1	Preserving Accuracy Over Wide Temperature Range Operation	10
General Description	1	Thermal Response Time	10
Revision History	2	Switching Loads with the Open-Collector Outputs	11
Specifications.....	3	High Current Switching	12
TMP01EST, TMP01FP, TMP01FS	3	Buffering the Temperature Output Pin	13
TMP01FJ.....	4	Differential Transmitter.....	13
Absolute Maximum Ratings.....	5	4 mA to 20 mA Current Loop	13
Typical Performance Characteristics	6	Temperature-to-Frequency Converter	14
Theory of Operation	8	Isolation Amplifier	15
Temperature Hysteresis	8	Out-of-Range Warning.....	15
Programming the TMP01	8	Translating 5 mV/K to 10 mV/°C	16
Understanding Error Sources	9	Translating VPTAT to the Fahrenheit Scale	16
Safety Considerations in Heating and Cooling System Design	9	Outline Dimensions	17
Applications Information	10	Ordering Guide	18

REVISION HISTORY

7/09—Rev. D to Rev. E

Updated Format.....	Universal
Updated Outline Dimensions	18
Changes to Ordering Guide	19

1/02—Rev. C: Rev. D

Edits to General Descriptions Section	1
Edits to Specifications Section	2
Edits to Wafer Test Limits Section.....	4
Edits to Dice Characteristics Section	4
Edits to Ordering Guide	5

7/93—Revision 0: Initial Version

SPECIFICATIONS

TMP01ES, TMP01FP, TMP01FS

PDIP and SOIC packages. $V+ = 5\text{ V}$, $GND = 0\text{ V}$, $-40^{\circ}\text{C} \leq T_A \leq +85^{\circ}\text{C}$, unless otherwise noted.

Table 1.

Parameter	Symbol	Conditions	Min	Typ	Max	Unit
INPUTS SET HIGH, SET LOW						
Offset Voltage	V_{OS}			0.25		mV
Offset Voltage Drift	TCV_{OS}			3		$\mu\text{V}/^{\circ}\text{C}$
Input Bias Current, E Grade	I_B			25	50	nA
Input Bias Current, F Grade	I_B			25	100	nA
OUTPUT VPTAT						
Output Voltage	VPTAT	$T_A = 25^{\circ}\text{C}$, no load		1.49		V
Scale Factor ¹	TCV_{PTAT}			5		mV/K
Temperature Accuracy, E Grade		$T_A = 25^{\circ}\text{C}$, no load	-1.5	± 0.5	1.5	$^{\circ}\text{C}$
Temperature Accuracy, F Grade		$T_A = 25^{\circ}\text{C}$, no load	-3	± 1.0	3	$^{\circ}\text{C}$
Temperature Accuracy, E Grade		$10^{\circ}\text{C} < T_A < 40^{\circ}\text{C}$, no load		± 0.75		$^{\circ}\text{C}$
Temperature Accuracy, F Grade		$10^{\circ}\text{C} < T_A < 40^{\circ}\text{C}$, no load		± 1.5		$^{\circ}\text{C}$
Temperature Accuracy, E Grade		$-40^{\circ}\text{C} < T_A < 85^{\circ}\text{C}$, no load	-3.0	± 1	3.0	$^{\circ}\text{C}$
Temperature Accuracy, F Grade		$-40^{\circ}\text{C} < T_A < 85^{\circ}\text{C}$, no load	-5.0	± 2	5.0	$^{\circ}\text{C}$
Temperature Accuracy, E Grade		$-55^{\circ}\text{C} < T_A < 125^{\circ}\text{C}$, no load		± 1.5		$^{\circ}\text{C}$
Temperature Accuracy, F Grade	ΔV_{PTAT}	$-55^{\circ}\text{C} < T_A < 125^{\circ}\text{C}$, no load		± 2.5		$^{\circ}\text{C}$
Repeatability Error ²				0.25		Degree
Long-Term Drift Error ^{3,4}				0.25	0.5	Degree
Power Supply Rejection Ratio	PSRR	$T_A = 25^{\circ}\text{C}$, $4.5\text{ V} \leq V+ \leq 13.2\text{ V}$		± 0.02	± 0.1	%/V
OUTPUT VREF						
Output Voltage, E Grade	VREF	$T_A = 25^{\circ}\text{C}$, no load	2.495	2.500	2.505	V
Output Voltage, F Grade	VREF	$T_A = 25^{\circ}\text{C}$, no load	2.490	2.500	2.510	V
Output Voltage, E Grade	VREF	$-40^{\circ}\text{C} < T_A < 85^{\circ}\text{C}$, no load	2.490	2.500	2.510	V
Output Voltage, F Grade	VREF	$-40^{\circ}\text{C} < T_A < 85^{\circ}\text{C}$, no load	2.485	2.500	2.515	V
Output Voltage, E Grade	VREF	$-55^{\circ}\text{C} < T_A < 125^{\circ}\text{C}$, no load		2.5 ± 0.01		V
Output Voltage, F Grade	VREF	$-55^{\circ}\text{C} < T_A < 125^{\circ}\text{C}$, no load		2.5 ± 0.015		V
Drift	TC_{VREF}			-10		ppm/ $^{\circ}\text{C}$
Line Regulation		$4.5\text{ V} \leq V+ \leq 13.2\text{ V}$		± 0.01	± 0.05	%/V
Load Regulation		$10\ \mu\text{A} \leq I_{VREF} \leq 500\ \mu\text{A}$		± 0.1	± 0.25	%/mA
Output Current, Zero Hysteresis	I_{VREF}			7		μA
Hysteresis Current Scale Factor ¹	SF_{HYS}			5.0		$\mu\text{A}/^{\circ}\text{C}$
Turn-On Settling Time		To rated accuracy		25		μs
OPEN-COLLECTOR OUTPUTS OVER, UNDER						
Output Low Voltage	V_{OL}	$I_{SINK} = 1.6\text{ mA}$		0.25	0.4	V
	V_{OL}	$I_{SINK} = 20\text{ mA}$		0.6		V
Output Leakage Current	I_{OH}	$V+ = 12\text{ V}$		1	100	μA
Fall Time	t_{HL}	See Figure 2		40		ns
POWER SUPPLY						
Supply Range	V+		4.5		13.2	V
Supply Current	I_{SY}	Unloaded, $V+ = 5\text{ V}$		400	500	μA
	I_{SY}	Unloaded, $V+ = 13.2\text{ V}$		450	800	μA
Power Dissipation	P_{DISS}	$V+ = 5\text{ V}$		2.0	2.5	mW

¹ $K = ^{\circ}\text{C} + 273.15$.

² Maximum deviation between 25°C readings after temperature cycling between -55°C and $+125^{\circ}\text{C}$.

³ Guaranteed but not tested.

⁴ Observed in a group sample over an accelerated life test of 500 hours at 150°C .

TMP01

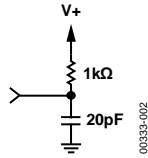

Figure 2. Test Load

TMP01FJ

TO-99 metal can package. $V_+ = 5\text{ V}$, $GND = 0\text{ V}$, $-40^\circ\text{C} \leq T_A \leq +85^\circ\text{C}$, unless otherwise noted.

Table 2.

Parameter	Symbol	Conditions	Min	Typ	Max	Unit
INPUTS SET HIGH, SET LOW						
Offset Voltage	V_{OS}			0.25		mV
Offset Voltage Drift	TCV_{OS}			3		$\mu\text{V}/^\circ\text{C}$
Input Bias Current, F Grade	I_B			25	100	nA
OUTPUT VPTAT						
Output Voltage	VPTAT	$T_A = 25^\circ\text{C}$, no load		1.49		V
Scale Factor ¹	TCV_{PTAT}			5		mV/K
Temperature Accuracy, F Grade		$T_A = 25^\circ\text{C}$, no load	-3	± 1.0	3	$^\circ\text{C}$
Temperature Accuracy, F Grade		$10^\circ\text{C} < T_A < 40^\circ\text{C}$, no load		± 1.5		$^\circ\text{C}$
Temperature Accuracy, F Grade		$-40^\circ\text{C} < T_A < 85^\circ\text{C}$, no load	-5.0	± 2	5.0	$^\circ\text{C}$
Temperature Accuracy, F Grade	ΔV_{PTAT}	$-55^\circ\text{C} < T_A < 125^\circ\text{C}$, no load		± 2.5		$^\circ\text{C}$
Repeatability Error ²				0.25		Degree
Long-Term Drift Error ^{3, 4}				0.25	0.5	Degree
Power Supply Rejection Ratio	PSRR	$T_A = 25^\circ\text{C}$, $4.5\text{ V} \leq V_+ \leq 13.2\text{ V}$		± 0.02	± 0.1	%/V
OUTPUT VREF						
Output Voltage, F Grade	VREF	$T_A = 25^\circ\text{C}$, no load	2.490	2.500	2.510	V
Output Voltage, F Grade	VREF	$-40^\circ\text{C} < T_A < 85^\circ\text{C}$, no load	2.485	2.500	2.515	V
Output Voltage, F Grade	VREF	$-55^\circ\text{C} < T_A < 125^\circ\text{C}$, no load		2.5 ± 0.015		V
Drift	TC_{VREF}			-10		ppm/ $^\circ\text{C}$
Line Regulation		$4.5\text{ V} \leq V_+ \leq 13.2\text{ V}$		± 0.01	± 0.05	%/V
Load Regulation		$10\ \mu\text{A} \leq I_{VREF} \leq 500\ \mu\text{A}$		± 0.1	± 0.25	%/mA
Output Current, Zero Hysteresis	I_{VREF}			7		μA
Hysteresis Current Scale Factor ¹	SF_{HYS}			5.0		$\mu\text{A}/^\circ\text{C}$
Turn-On Settling Time		To rated accuracy		25		μs
OPEN-COLLECTOR OUTPUTS OVER, UNDER						
Output Low Voltage	V_{OL}	$I_{SINK} = 1.6\text{ mA}$		0.25	0.4	V
	V_{OL}	$I_{SINK} = 20\text{ mA}$		0.6		V
Output Leakage Current	I_{OH}	$V_+ = 12\text{ V}$		1	100	μA
Fall Time	t_{HL}	See Figure 2		40		ns
POWER SUPPLY						
Supply Range	V_+		4.5		13.2	V
Supply Current	I_{SY}	Unloaded, $+V = 5\text{ V}$		400	500	μA
	I_{SY}	Unloaded, $+V = 13.2\text{ V}$		450	800	μA
Power Dissipation	P_{DISS}	$+V = 5\text{ V}$		2.0	2.5	mW

¹ $K = ^\circ\text{C} + 273.15$.

²Maximum deviation between 25°C readings after temperature cycling between -55°C and $+125^\circ\text{C}$.

³Guaranteed but not tested.

⁴Observed in a group sample over an accelerated life test of 500 hours at 150°C .

ABSOLUTE MAXIMUM RATINGS

Table 3.

Parameter	Rating
Maximum Supply Voltage	-0.3 V to +15 V
Maximum Input Voltage (SET HIGH, SET LOW)	-0.3 V to V+ +0.3 V
Maximum Output Current (VREF, VPTAT)	2 mA
Maximum Output Current (Open-Collector Outputs)	50 mA
Maximum Output Voltage (Open-Collector Outputs)	15 V
Operating Temperature Range	-55°C to +150°C
Die Junction Temperature	150°C
Storage Temperature Range	-65°C to +150°C
Lead Temperature (Soldering 60 sec)	300°C

Stresses above those listed under Absolute Maximum Ratings may cause permanent damage to the device. This is a stress rating only; functional operation of the device at these or any other conditions above those indicated in the operational section of this specification is not implied. Exposure to absolute maximum rating conditions for extended periods may affect device reliability.

Digital inputs and outputs are protected; however, permanent damage may occur on unprotected units from high energy electrostatic fields. Keep units in conductive foam or packaging at all times until ready to use. Use proper antistatic handling procedures.

Remove power before inserting or removing units from their sockets.

Table 4.

Package Type	θ_{JA}	θ_{JC}	Unit
8-Lead PDIP (N-8)	103 ¹	43	°C/W
8-Lead SOIC (R-8)	158 ²	43	°C/W
8-Pin TO-99 Can (H-08)	150 ¹	18	°C/W

¹ θ_{JA} is specified for device in socket (worst-case conditions).

² θ_{JA} is specified for device mounted on PCB.

ESD CAUTION



ESD (electrostatic discharge) sensitive device. Charged devices and circuit boards can discharge without detection. Although this product features patented or proprietary protection circuitry, damage may occur on devices subjected to high energy ESD. Therefore, proper ESD precautions should be taken to avoid performance degradation or loss of functionality.

TYPICAL PERFORMANCE CHARACTERISTICS

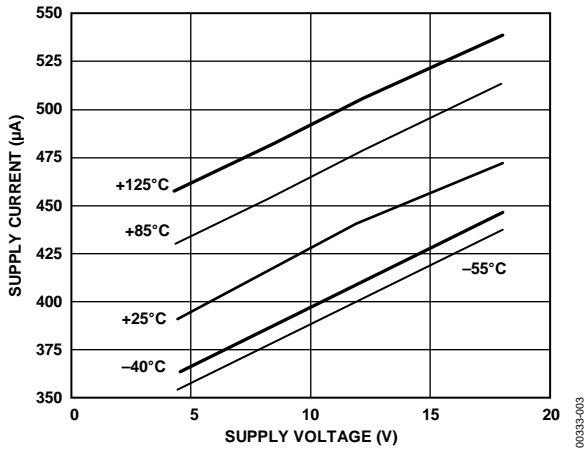

Figure 3. Supply Current vs. Supply Voltage

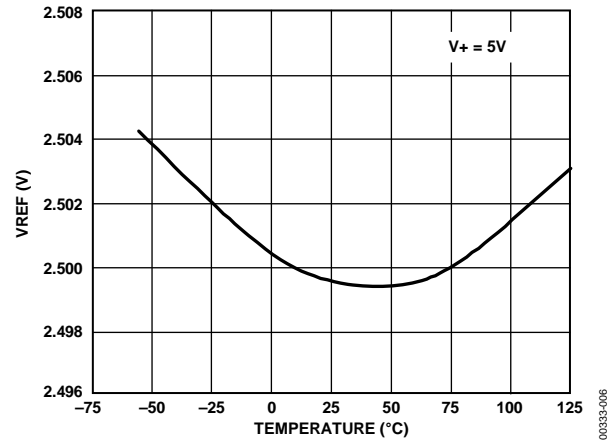

Figure 6. VREF Accuracy vs. Temperature

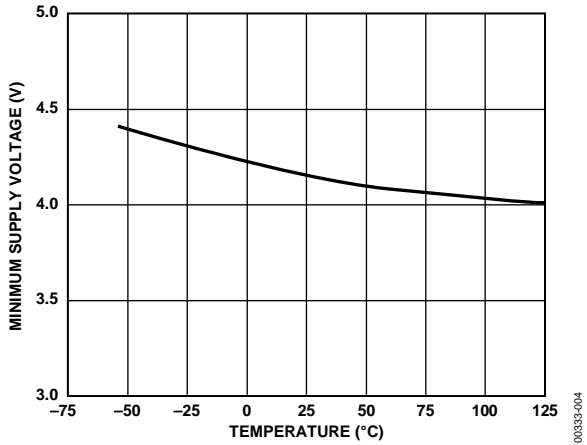

Figure 4. Minimum Supply Voltage vs. Temperature

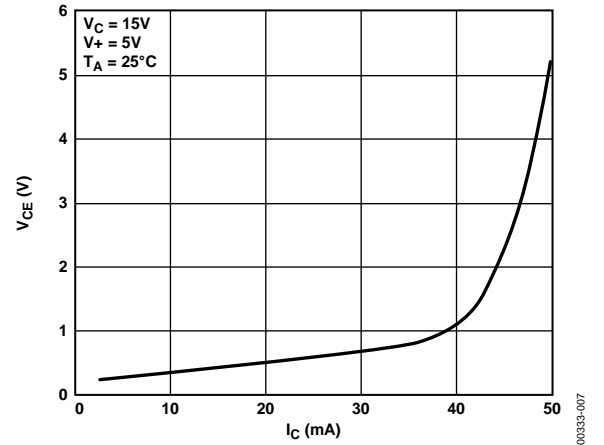

Figure 7. Open-Collector Output (OVER, UNDER) Saturation Voltage vs. Output Current

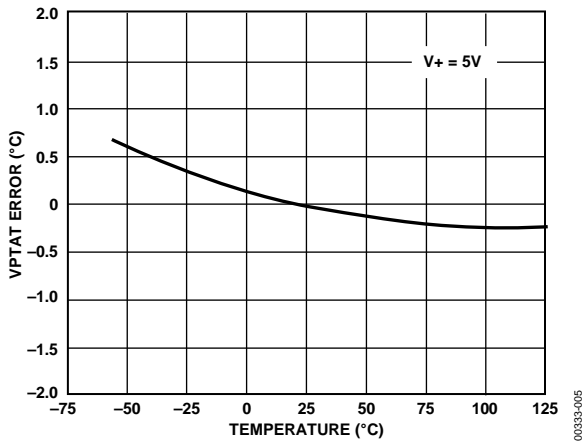

Figure 5. VPTAT Accuracy vs. Temperature

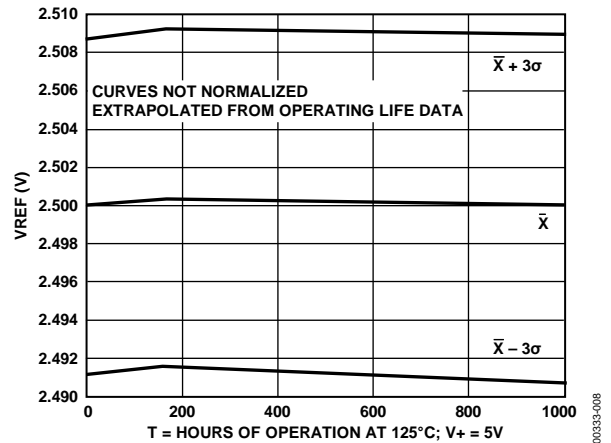

Figure 8. VREF Long Term Drift Accelerated by Burn-In

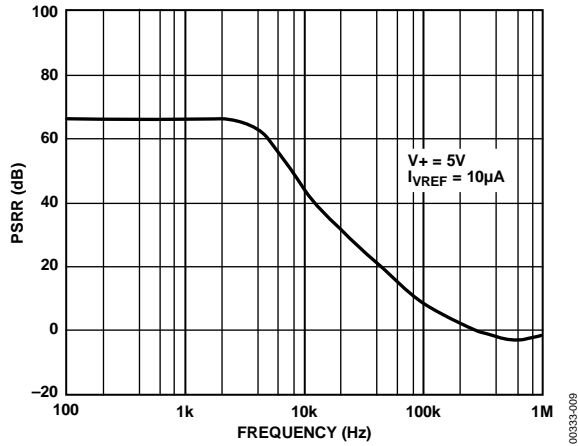

Figure 9. VREF Power Supply Rejection vs. Frequency

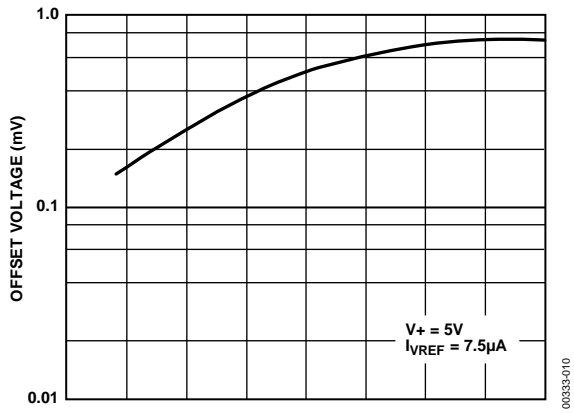

Figure 10. Set High, Set Low Input Offset Voltage vs. Temperature

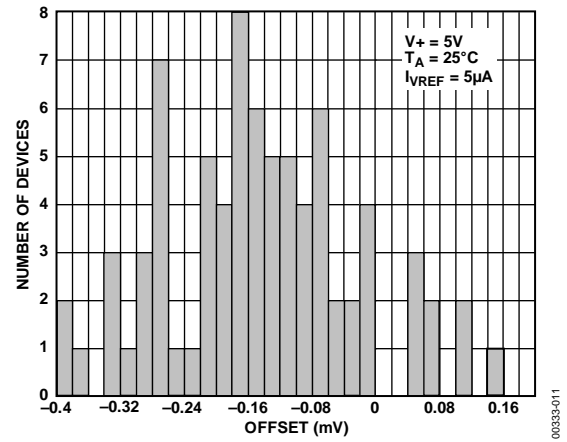

Figure 11. Comparator Input Offset Distribution

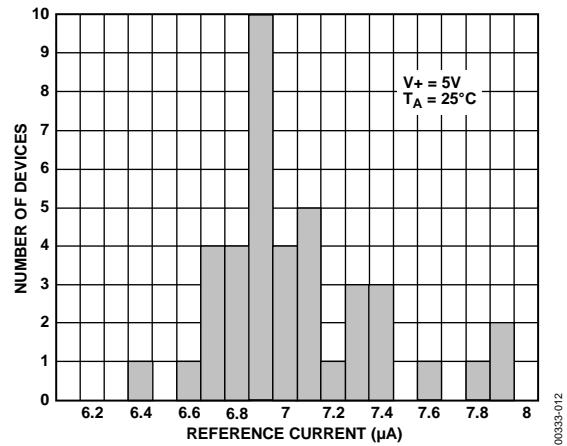

Figure 12. Zero Hysteresis Current Distribution

THEORY OF OPERATION

The TMP01 is a linear voltage-output temperature sensor, with a window comparator that can be programmed by the user to activate one of two open-collector outputs when a predetermined temperature setpoint voltage has been exceeded. A low drift voltage reference is available for setpoint programming.

The temperature sensor is basically a very accurate, temperature compensated, band gap-type voltage reference with a buffered output voltage proportional to absolute temperature (VPTAT), accurately trimmed to a scale factor of 5 mV/K.

The low drift 2.5 V reference output VREF is easily divided externally with fixed resistors or potentiometers to accurately establish the programmed heat/cool setpoints, independent of temperature. Alternatively, the setpoint voltages can be supplied by other ground referenced voltage sources such as user-programmed DACs or controllers. The high and low setpoint voltages are compared to the temperature sensor voltage, thus creating a two-temperature thermostat function. In addition, the total output current of the reference (I_{VREF}) determines the magnitude of the temperature hysteresis band. The open collector outputs of the comparators can be used to control a wide variety of devices.

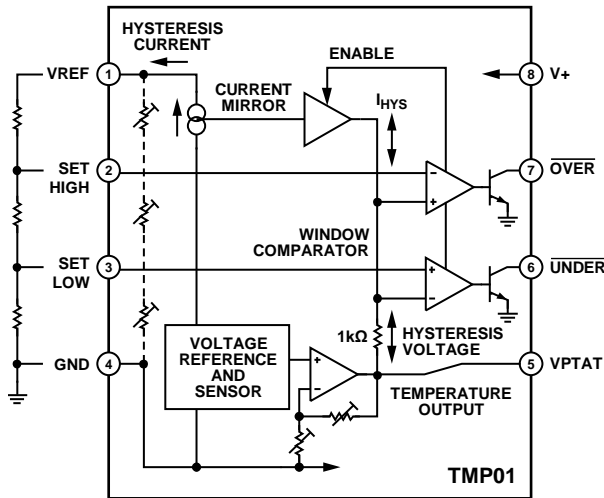

Figure 13. Detailed Block Diagram

TEMPERATURE HYSTERESIS

The temperature hysteresis is the number of degrees beyond the original setpoint temperature that must be sensed by the TMP01 before the setpoint comparator is reset and the output disabled. Figure 14 shows the hysteresis profile. The hysteresis is programmed by the user by setting a specific load on the reference voltage output VREF. This output current I_{VREF} is also called the hysteresis current, which is mirrored internally and fed to a buffer with an analog switch.

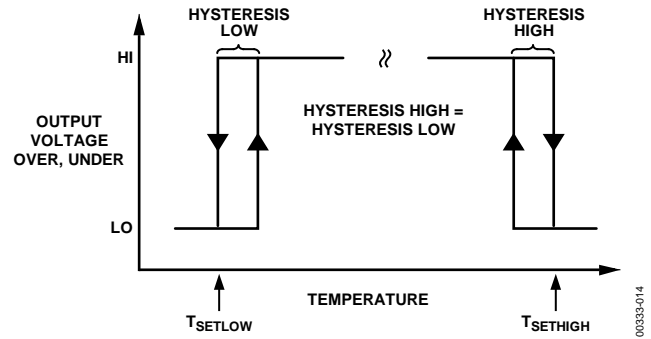

Figure 14. TMP01 Hysteresis Profile

After a temperature setpoint is exceeded and a comparator tripped, the buffer output is enabled. The output is a current of the appropriate polarity that generates a hysteresis offset voltage across an internal 1000 Ω resistor at the comparator input. The comparator output remains on until the voltage at the comparator input, now equal to the temperature sensor voltage VPTAT summed with the hysteresis offset, returns to the programmed setpoint voltage. The comparator then returns low, deactivating the open-collector output and disabling the hysteresis current buffer output. The scale factor for the programmed hysteresis current is:

$$I_{HYS} = I_{VREF} = 5 \mu\text{A}/^\circ\text{C} + 7 \mu\text{A}$$

Thus, since $V_{REF} = 2.5 \text{ V}$, with a reference load resistance of 357 k Ω or greater (output current 7 μA or less), the temperature setpoint hysteresis is zero degrees. Larger values of load resistance only decrease the output current below 7 μA and have no effect on the operation of the device. The amount of hysteresis is determined by selecting a value of load resistance for VREF.

PROGRAMMING THE TMP01

In the basic fixed setpoint application utilizing a simple resistor ladder voltage divider, the desired temperature setpoints are programmed in the following sequence:

1. Select the desired hysteresis temperature.
2. Calculate the hysteresis current I_{VREF} .
3. Select the desired setpoint temperatures.
4. Calculate the individual resistor divider ladder values needed to develop the desired comparator setpoint voltages at SET HIGH and SET LOW.

The hysteresis current is readily calculated. For example, for 2 degrees of hysteresis, $I_{VREF} = 17 \mu\text{A}$. Next, the setpoint voltages, $V_{SETHIGH}$ and V_{SETLOW} , are determined using the VPTAT scale factor of $5 \text{ mV/K} = 5 \text{ mV}/(^{\circ}\text{C} + 273.15)$, which is 1.49 V for 25°C . Then, calculate the divider resistors, based on those setpoints. The equations used to calculate the resistors are

$$V_{SETHIGH} = (T_{SETHIGH} + 273.15) (5 \text{ mV}/^{\circ}\text{C})$$

$$V_{SETLOW} = (T_{SETLOW} + 273.15) (5 \text{ mV}/^{\circ}\text{C})$$

$$R1 (k\Omega) = (V_{VREF} - V_{SETHIGH})/I_{VREF} = (2.5 \text{ V} - V_{SETHIGH})/I_{VREF}$$

$$R2 (k\Omega) = (V_{SETHIGH} - V_{SETLOW})/I_{VREF}$$

$$R3 (k\Omega) = V_{SETLOW}/I_{VREF}$$

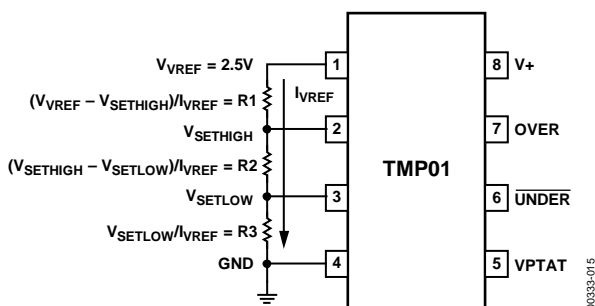

Figure 15. TMP01 Setpoint Programming

The total $R1 + R2 + R3$ is equal to the load resistance needed to draw the desired hysteresis current from the reference, or I_{VREF} .

The formulas shown above are also helpful in understanding the calculation of temperature setpoint voltages in circuits other than the standard two-temperature thermostat. If a setpoint function is not needed, the appropriate comparator should be disabled. SET HIGH can be disabled by tying it to $V+$, SET LOW by tying it to GND. Either output can be left unconnected.

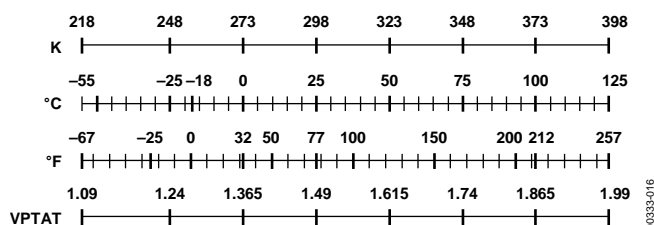

Figure 16. Temperature—VPTAT Scale

UNDERSTANDING ERROR SOURCES

The accuracy of the VPTAT sensor output is well characterized and specified; however, preserving this accuracy in a heating or cooling control system requires some attention to minimizing the various potential error sources. The internal sources of setpoint programming error include the initial tolerances and temperature drifts of the reference voltage V_{REF} , the setpoint comparator input offset voltage and bias current, and the hysteresis current scale factor. When evaluating setpoint programming errors, remember that any V_{REF} error contribution at the comparator inputs is reduced by the

resistor divider ratios. The comparator input bias current (inputs SET HIGH, SET LOW) drops to less than 1 nA (typ) when the comparator is tripped. This can account for some setpoint voltage error, equal to the change in bias current times the effective setpoint divider ladder resistance to ground.

The thermal mass of the TMP01 package and the degree of thermal coupling to the surrounding circuitry are the largest factors in determining the rate of thermal settling, which ultimately determines the rate at which the desired temperature measurement accuracy may be reached. Thus, allow sufficient time for the device to reach the final temperature. The typical thermal time constant for the plastic package is approximately 140 seconds in still air. Therefore, to reach the final temperature accuracy within 1%, for a temperature change of 60 degrees, a settling time of 5 time constants, or 12 minutes, is necessary.

The setpoint comparator input offset voltage and zero hysteresis current affect setpoint error. While the $7 \mu\text{A}$ zero hysteresis current allows the user to program the TMP01 with moderate resistor divider values, it does vary somewhat from device to device, causing slight variations in the actual hysteresis obtained in practice. Comparator input offset directly impacts the programmed setpoint voltage and thus the resulting hysteresis band, and must be included in error calculations.

External error sources to consider are the accuracy of the programming resistors, grounding error voltages, and the overall problem of thermal gradients. The accuracy of the external programming resistors directly impacts the resulting setpoint accuracy. Thus, in fixed-temperature applications, the user should select resistor tolerances appropriate to the desired programming accuracy. Resistor temperature drift must be taken into account also. This effect can be minimized by selecting good quality components, and by keeping all components in close thermal proximity. Applications requiring high measurement accuracy require great attention to detail regarding thermal gradients. Careful circuit board layout, component placement, and protection from stray air currents are necessary to minimize common thermal error sources.

Also, the user should take care to keep the bottom of the setpoint programming divider ladder as close to GND (Pin 4) as possible to minimize errors due to IR voltage drops and coupling of external noise sources. In any case, a $0.1 \mu\text{F}$ capacitor for power supply bypassing is always recommended at the chip.

SAFETY CONSIDERATIONS IN HEATING AND COOLING SYSTEM DESIGN

Designers should anticipate potential system fault conditions, which may result in significant safety hazards, which are outside the control of and cannot be corrected by the TMP01-based circuit. Observe governmental and industrial regulations regarding safety requirements and standards for such designs where applicable.

APPLICATIONS INFORMATION

SELF-HEATING EFFECTS

In some applications, the user should consider the effects of self-heating due to the power dissipated by the open-collector outputs, which are capable of sinking 20 mA continuously. Under full load, the TMP01 open-collector output device is dissipating

$$P_{DISS} = 0.6 \text{ V} \times .020 \text{ A} = 12 \text{ mW}$$

which in a surface-mount SOIC package accounts for a temperature increase due to self-heating of

$$\Delta T = P_{DISS} \times \theta_{JA} = .012 \text{ W} \times 158^\circ\text{C/W} = 1.9^\circ\text{C}$$

This self-heating effect directly affects the accuracy of the TMP01 and will, for example, cause the device to activate the OVER output 2 degrees early.

Bonding the package to a moderate heat sink limits the self-heating effect to approximately:

$$\Delta T = P_{DISS} \times \theta_{JC} = .012 \text{ W} \times 43^\circ\text{C/W} = 0.52^\circ\text{C}$$

which is a much more tolerable error in most systems. The VREF and VPTAT outputs are also capable of delivering sufficient current to contribute heating effects and should not be ignored.

BUFFERING THE VOLTAGE REFERENCE

The reference output VREF is used to generate the temperature setpoint programming voltages for the TMP01 and also to determine the hysteresis temperature band by the reference load current I_{VREF} . The on-board output buffer amplifier is typically capable of 500 μA output drive into as much as 50 pF load (maximum). Exceeding this load affects the accuracy of the reference voltage, could cause thermal sensing errors due to dissipation, and may induce oscillations. Selection of a low drift buffer functioning as a voltage follower with high input impedance ensures optimal reference accuracy, and does not affect the programmed hysteresis current. Amplifiers which offer the low drift, low power consumption, and low cost appropriate to this application include the OP295, and members of the OP90, OP97, OP177 families, and others as shown in the following applications circuits.

With excellent drift and noise characteristics, VREF offers a good voltage reference for data acquisition and transducer excitation applications as well. Output drift is typically better than $-10 \text{ ppm}/^\circ\text{C}$, with $315 \text{ nV}/\sqrt{\text{Hz}}$ (typ) noise spectral density at 1 kHz.

PRESERVING ACCURACY OVER WIDE TEMPERATURE RANGE OPERATION

The TMP01 is unique in offering both a wide range temperature sensor and the associated detection circuitry needed to implement a complete thermostatic control function in one monolithic device. While the voltage reference, setpoint comparators, and output buffer amplifiers have been carefully compensated to maintain accuracy over the specified temperature range, the user has an additional task in maintaining the accuracy over wide operating temperature ranges in the application.

Since the TMP01 is both sensor and control circuit, in many applications it is possible that the external components used to program and interface the device may be subjected to the same temperature extremes. Thus, it may be necessary to locate components in close thermal proximity to minimize large temperature differentials, and to account for thermal drift errors, such as resistor matching tempcos, amplifier error drift, and the like, where appropriate. Circuit design with the TMP01 requires a slightly different perspective regarding the thermal behavior of electronic components.

THERMAL RESPONSE TIME

The time required for a temperature sensor to settle to a specified accuracy is a function of the thermal mass of the sensor, and the thermal conductivity between the sensor and the object being sensed. Thermal mass is often considered equivalent to capacitance.

Thermal conductivity is commonly specified using the symbol Q , and can be thought of as the reciprocal of thermal resistance. It is commonly specified in units of degrees per watt of power transferred across the thermal joint. Thus, the time required for the TMP01 to settle to the desired accuracy is dependent on the package selected, the thermal contact established in that particular application, and the equivalent power of the heat source. In most applications, the settling time is probably best determined empirically.

SWITCHING LOADS WITH THE OPEN-COLLECTOR OUTPUTS

In many temperature sensing and control applications, some type of switching is required. Whether it be to turn on a heater when the temperature goes below a minimum value or to turn off a motor that is overheating, the open-collector outputs OVER and UNDER can be used. For the majority of applications, the switches used need to handle large currents on the order of 1 A and above. Because the TMP01 is accurately measuring temperature, the open-collector outputs should handle less than 20 mA of current to minimize self-heating.

The OVER and UNDER outputs should not drive the equipment directly. Instead, an external switching device is required to handle the large currents. Some examples of these are relays, power MOSFETs, thyristors, IGBTs, and Darlingtons.

Figure 17 through Figure 21 show a variety of circuits where the TMP01 controls a switch. The main consideration in these circuits, such as the relay in Figure 17, is the current required to activate the switch.

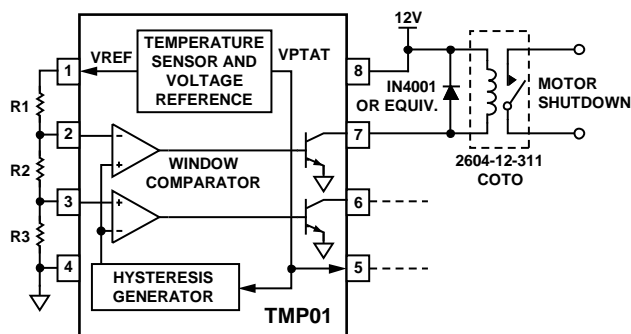

Figure 17. Reed Relay Drive

It is important to check the particular relay to ensure that the current needed to activate the coil does not exceed the TMP01's recommended output current of 20 mA. This is easily determined by dividing the relay coil voltage by the specified coil resistance. Keep in mind that the inductance of the relay creates large voltage spikes that can damage the TMP01 output unless protected by a commutation diode across the coil, as shown.

The relay shown has a contact rating of 10 W maximum. If a relay capable of handling more power is desired, the larger contacts probably require a commensurately larger coil, with lower coil resistance and thus higher trigger current. As the contact power handling capability increases, so does the current needed for the coil. In some cases, an external driving transistor should be used to remove the current load on the TMP01.

Power FETs are popular for handling a variety of high current dc loads. Figure 18 shows the TMP01 driving a p-channel MOSFET transistor for a simple heater circuit. When the output transistor turns on, the gate of the MOSFET is pulled down to approximately 0.6 V, turning it on. For most MOSFETs, a gate-to-source voltage, or V_{gs} , on the order of -2 V to -5 V is sufficient to turn the device on.

Figure 19 shows a similar circuit for turning on an n-channel MOSFET, except that now the gate to source voltage is positive. For this reason, an external transistor must be used as an inverter so that the MOSFET turns on when the UNDER output pulls down.

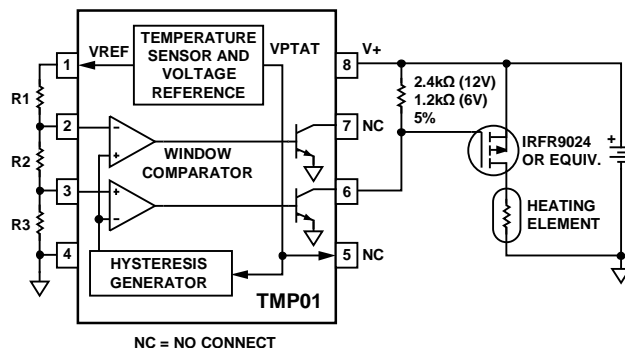

Figure 18. Driving a P-Channel MOSFET

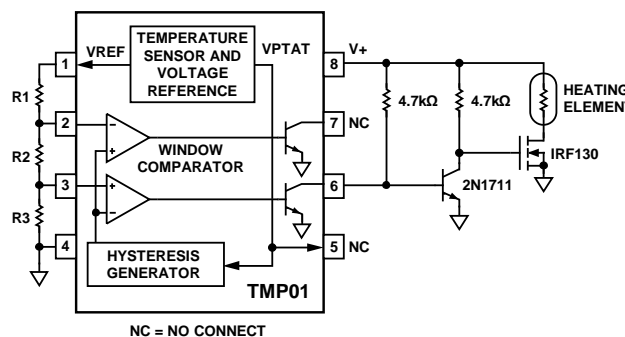

Figure 19. Driving an N-Channel MOSFET

Isolated gate bipolar transistors (IGBT) combine many of the benefits of power MOSFETs with bipolar transistors, and are used for a variety of high power applications. Because IGBTs have a gate similar to MOSFETs, turning on and off the devices is relatively simple as shown in Figure 20.

The turn-on voltage for the IGBT shown (IRGBC40S) is between 3.0 V and 5.5 V. This part has a continuous collector current rating of 50 A and a maximum collector-to-emitter voltage of 600 V, enabling it to work in very demanding applications.

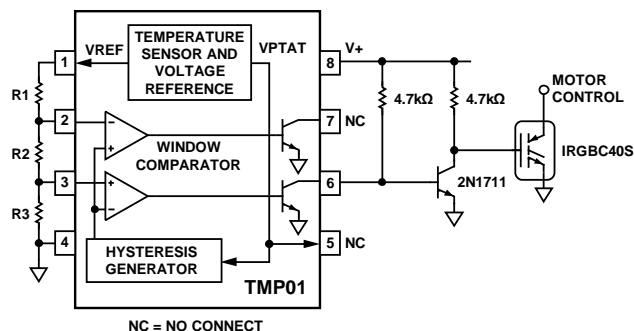

Figure 20. Driving an IGBT

TMP01

The last class of high power devices discussed here are thyristors, which includes SCRs and Triacs. Triacs are a useful alternative to relays for switching ac line voltages. The 2N6073A shown in Figure 21 is rated to handle 4A (rms). The opto-isolated MOC3011 Triac features excellent electrical isolation from the noisy ac line and complete control over the high power Triac with only a few additional components.

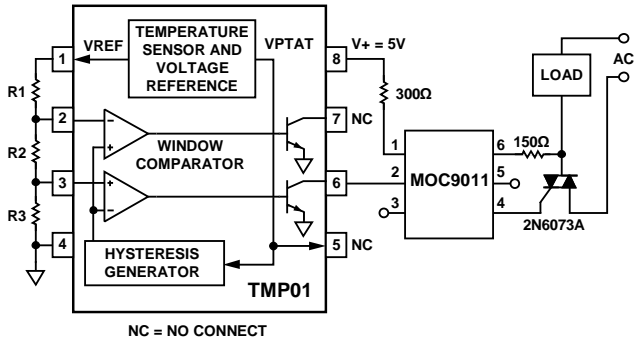

Figure 21. Controlling the 2N6073A Triac

HIGH CURRENT SWITCHING

Internal dissipation due to large loads on the TMP01 outputs causes some temperature error due to self-heating. External transistors remove the load from the TMP01, so that virtually no power is dissipated in the internal transistors and no self-heating occurs. Figure 22 through Figure 24 show a few examples using external transistors. The simplest case, using a single transistor on the output to invert the output signal is shown in Figure 22. When the open collector of the TMP01 turns on and pulls the output down, the external transistor Q1 base is pulled low, turning off the transistor. Another transistor can be added to reinvert the signal as shown in Figure 23. Now, when the output of the TMP01 is pulled down, the first transistor, Q1, turns off and its collector goes high, which turns Q2 on, pulling its collector low.

Thus, the output taken from the collector of Q2 is identical to the output of the TMP01. By picking a transistor that can accommodate large amounts of current, many high power devices can be switched.

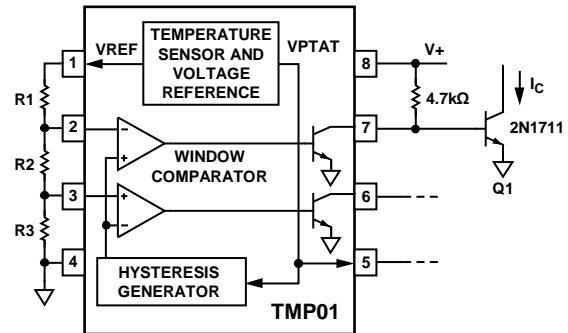

Figure 22. An External Resistor Minimizes Self-Heating

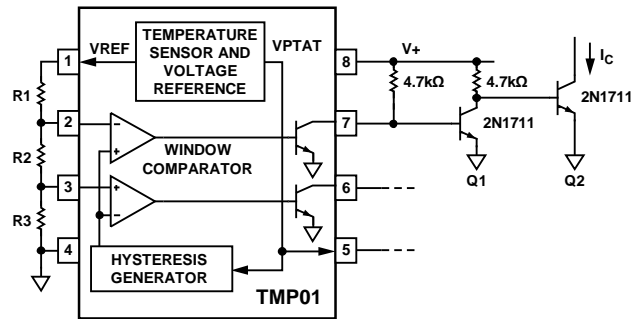

Figure 23. Second Transistor Maintains Polarity of TMP01 Output

An example of a higher power transistor is a standard Darlington configuration as shown in Figure 24. The part chosen, TIP-110, can handle 2 A continuous which is more than enough to control many high power relays. In fact, the Darlington itself can be used as the switch, similar to MOSFETs and IGBTs.

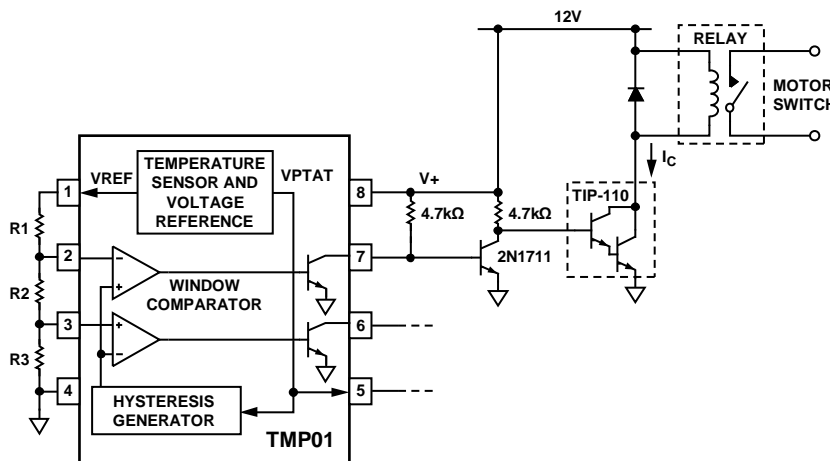

Figure 24. Darlington Transistor Can Handle Large Currents

BUFFERING THE TEMPERATURE OUTPUT PIN

The VPTAT sensor output is a low impedance dc output voltage with a 5 mV/K temperature coefficient, that is useful in multiple measurement and control applications. In many applications, this voltage needs to be transmitted to a central location for processing. The buffered VPTAT voltage output is capable of 500 μ A drive into 50 pF (maximum).

Consider external amplifiers for interfacing VPTAT to external circuitry to ensure accuracy, and to minimize loading which could create dissipation-induced temperature sensing errors. An excellent general-purpose buffer circuit using the OP177 is shown in Figure 25. It is capable of driving over 10 mA, and remains stable under capacitive loads of up to 0.1 μ F. Other interfacing ideas are also provided in this section.

DIFFERENTIAL TRANSMITTER

In noisy industrial environments, it is difficult to send an accurate analog signal over a significant distance. However, by sending the signal differentially on a wire pair, these errors can be significantly reduced. Because the noise is picked up equally on both wires, a receiver with high common-mode input rejection can be used to cancel out the noise very effectively at the receiving end. Figure 26 shows two amplifiers used to send the signal differentially, and an excellent differential receiver, the AMP03, which features a common-mode rejection ratio of 95 dB at dc and very low input and drift errors.

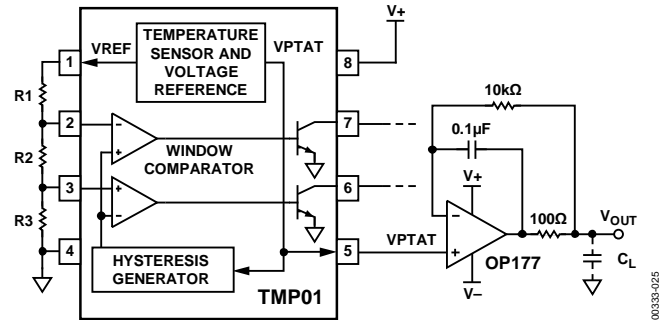

Figure 25. Buffer VPTAT to Handle Difficult Loads

4 mA TO 20 mA CURRENT LOOP

Another common method of transmitting a signal over long distances is to use a 4 mA to 20 mA loop, as shown in Figure 27. An advantage of using a 4 mA to 20 mA loop is that the accuracy of a current loop is not compromised by voltage drops across the line. One requirement of 4 mA to 20 mA circuits is that the remote end must receive all of its power from the loop, meaning that the circuit must consume less than 4 mA.

Operating from 5 V, the quiescent current of the TMP01 is 500 μ A maximum, and the OP90s is 20 μ A maximum, totaling less than 4 mA. Although not shown, the open collector outputs and temperature setting pins can be connected to do any local control of switching.

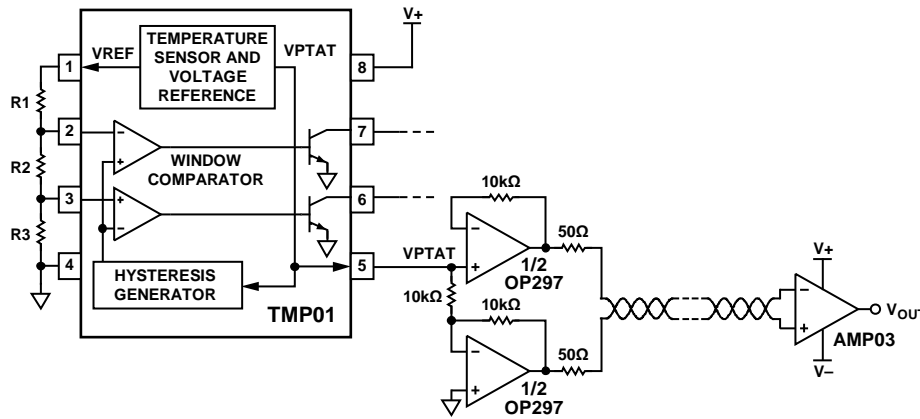

Figure 26. Send the Signal Differentially for Noise Immunity

TMP01

The current is proportional to the voltage on the VPTAT output, and is calibrated to 4 mA at a temperature of -40°C , to 20 mA for $+85^{\circ}\text{C}$. The main equation governing the operation of this circuit gives the current as a function of VPTAT

$$I_{OUT} = \frac{1}{R_6} \left(\frac{V_{PTAT} \times R_5}{R_2} - \frac{V_{REF} \times R_3}{R_3 + R_1} \left(1 + \frac{R_5}{R_2} \right) \right)$$

The resulting temperature coefficient of the output current is $128 \mu\text{A}/^{\circ}\text{C}$.

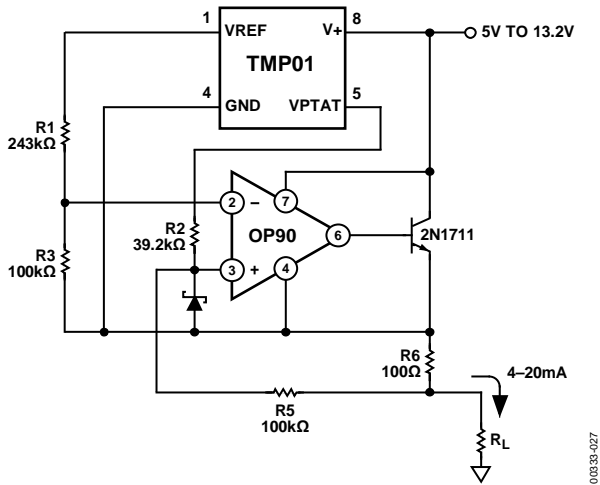

Figure 27. 4mA to 20mA Current Loop

To determine the resistor values in this circuit, first note that VREF remains constant over temperature. Thus, the ratio of R5 over R2 must give a variation of I_{OUT} from 4 mA to 20 mA as VPTAT varies from 1.165 V at -40°C to 1.79 V at $+85^{\circ}\text{C}$. The absolute value of the resistors is not important, only the ratio. For convenience, 100 kΩ is chosen for R5. Once R2 is calculated, the value of R3 and R1 is determined by substituting 4 mA for I_{OUT} and 1.165 V for VPTAT and solving. The final

values are shown in the circuit. The OP90 is chosen for this circuit because of its ability to operate on a single supply and its high accuracy. For initial accuracy, a 10 kΩ trim potentiometer can be included in series with R3, and the value of R3 lowered to 95 kΩ. The potentiometer should be adjusted to produce an output current of 12.3 mA at 25°C .

TEMPERATURE-TO-FREQUENCY CONVERTER

Another common method of transmitting analog information is to convert a voltage to the frequency domain. This is easily done with any of the low cost monolithic voltage-to-frequency converters (VFCs) available, which feature a robust, open-collector digital output. A digital signal is immune to noise and voltage drops because the only important information is the frequency. As long as the conversions between temperature and frequency are done accurately, the temperature data can be successfully transmitted.

A simple circuit to do this combines the TMP01 with an AD654 VFC, as shown in Figure 28. The AD654 outputs a square wave that is proportional to the dc input voltage according to the following equation:

$$F_{OUT} = \frac{V_{IN}}{10 (R_1 + R_2) C_T}$$

By simply connecting the VPTAT output to the input of the AD654, the $5 \text{ mV}/^{\circ}\text{C}$ temperature coefficient gives a sensitivity of $25 \text{ Hz}/^{\circ}\text{C}$, centered around 7.5 kHz at 25°C . The trimming resistor R2 is needed to calibrate the absolute accuracy of the AD654. For more information on that part, consult the AD654 data sheet. Finally, the AD654 can be used to accurately convert the frequency back to a dc voltage on the receiving end.

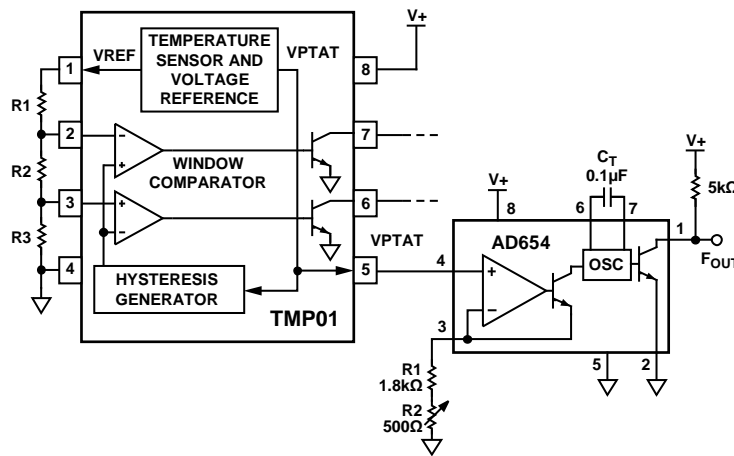

Figure 28. Temperature-to-Frequency Converter

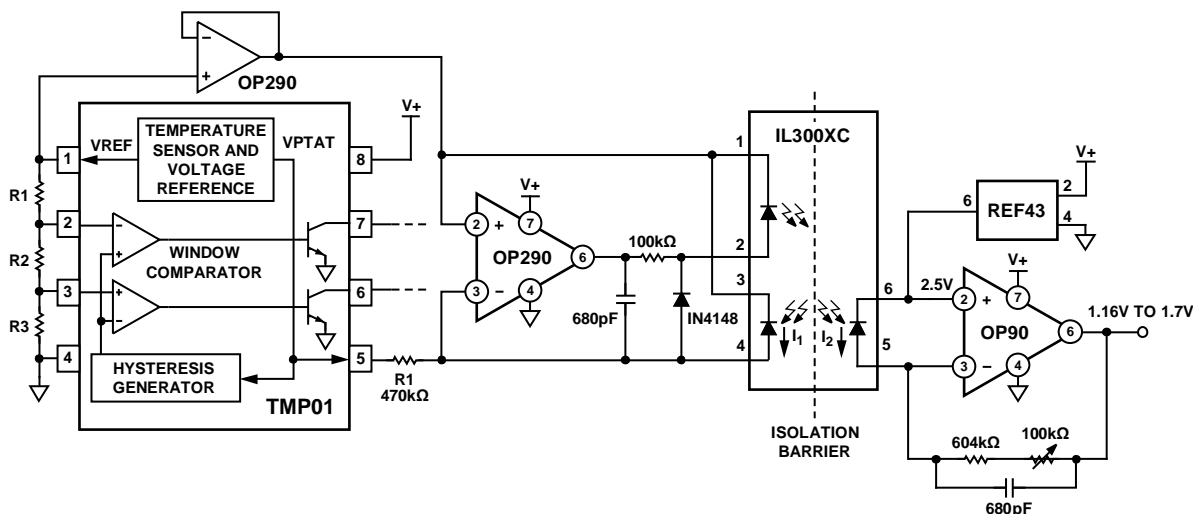

Figure 29. Isolation Amplifier

ISOLATION AMPLIFIER

In many industrial applications, the sensor is located in an environment that needs to be electrically isolated from the central processing area. Figure 29 shows a simple circuit that uses an 8-pin optoisolator (IL300XC) that can operate across a 5,000 V barrier. IC1 (an OP290 single-supply amplifier) is used to drive the LED connected between Pin 1 and Pin 2. The feedback actually comes from the photodiode connected from Pin 3 to Pin 4. The OP290 drives the LED such that there is enough current generated in the photodiode to exactly equal the current derived from the VPTAT voltage across the 470 kΩ resistor.

On the receiving end, an OP90 converts the current from the second photodiode to a voltage through its feedback resistor R2.

Note that the other amplifier in the dual OP290 is used to buffer the 2.5 V reference voltage of the TMP01 for an accurate, low drift LED bias level without affecting the programmed hysteresis current. A REF43 (a precision 2.5 V reference) provides an accurate bias level at the receiving end.

To understand this circuit, it helps to examine the overall equation for the output voltage. First, the current (I₁) in the photodiode is set by

$$I_1 = \frac{2.5\text{ V} - V_{PTAT}}{470\text{ k}\Omega}$$

Note that the IL300XC has a gain of 0.73 (typical) with a minimum and maximum of 0.693 and 0.769, respectively. Because this is less than 1.0, R2 must be larger than R1 to achieve overall unity gain. To show this, the full equation is

$$V_{OUT} = 2.5\text{ V} - I_2 R_2 = 2.5\text{ V} - 0.7 \left(\frac{2.5\text{ V} - V_{PTAT}}{470\text{ k}\Omega} \right) 644\text{ k}\Omega = V_{PTAT}$$

A trim is included for R2 to correct for the initial gain accuracy of the IL300XC. To perform this trim, simply adjust for an

output voltage equal to VPTAT at any particular temperature. For example, at room temperature, VPTAT = 1.49 V, so adjust R2 until V_{OUT} = 1.49 V as well. Both the REF43 and the OP90 operate from a single supply, and contribute no significant error due to drift.

In order to avoid the accuracy trim, and to reduce board space, complete isolation amplifiers are available, such as the high accuracy AD202.

OUT-OF-RANGE WARNING

By connecting the two open-collector outputs of the TMP01 together into a wired-OR configuration, a temperature out-of-range warning signal is generated. This can be useful in sensitive equipment calibrated to work over a limited temperature range.

R1, R2, and R3 in Figure 30 are chosen to give a temperature range of 10°C around room temperature (25°C). Thus, if the temperature in the equipment falls below 15°C or rises above 35°C, the OVER or UNDER output, respectively, goes low and turns the LED on. The LED may be replaced with a simple pull-up resistor to give a logic output for controlling the instrument, or any of the switching devices discussed above can be used.

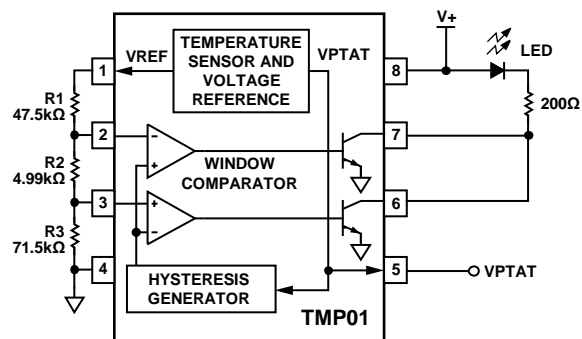

Figure 30. Out-of-Range Warning

TMP01

TRANSLATING 5 mV/K TO 10 mV/°C

A useful circuit shown in Figure 31 translates the VPTAT output voltage, which is calibrated in Kelvins, into an output that can be read directly in degrees Celsius on a voltmeter display.

To accomplish this, an external amplifier is configured as a differential amplifier. The resistors are scaled so the VREF voltage exactly cancels the VPTAT voltage at 0.0°C.

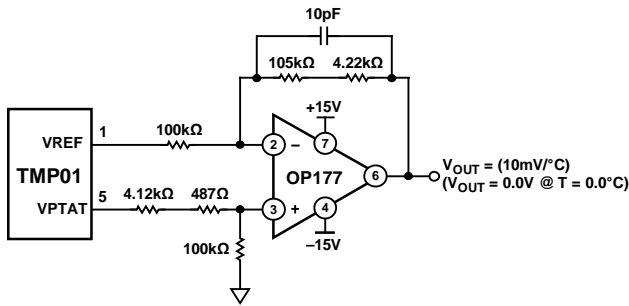

Figure 31. Translating 5 mV/K to 10 mV/°C

00333-031

However, the gain from VPTAT to the output is two, so that 5 mV/K becomes 10 mV/°C. Thus, for a temperature of 80°C, the output voltage is 800 mV. Circuit errors will be due primarily to the inaccuracies of the resistor values. Using 1% resistors, the observed error was less than 10 mV, or 1°C. The 10 pF feedback capacitor helps to ensure against oscillations. For better accuracy, an adjustment potentiometer can be added in series with either 100 kΩ resistor.

TRANSLATING VPTAT TO THE FAHRENHEIT SCALE

A similar circuit to the one shown in Figure 31 can be used to translate VPTAT into an output that can be read directly in degrees Fahrenheit, with a scaling of 10 mV/°F. Only unity gain or less is available from the first stage differentiating circuit, so the second amplifier provides a gain of two to complete the conversion to the Fahrenheit scale. Using the circuit in Figure 32, a temperature of 0.0°F gives an output of 0.00 V. At room temperature (70°F), the output voltage is 700 mV. A -40°C to +85°C operating range translates into -40°F to +185°F. The errors are essentially the same as for the circuit in Figure 31.

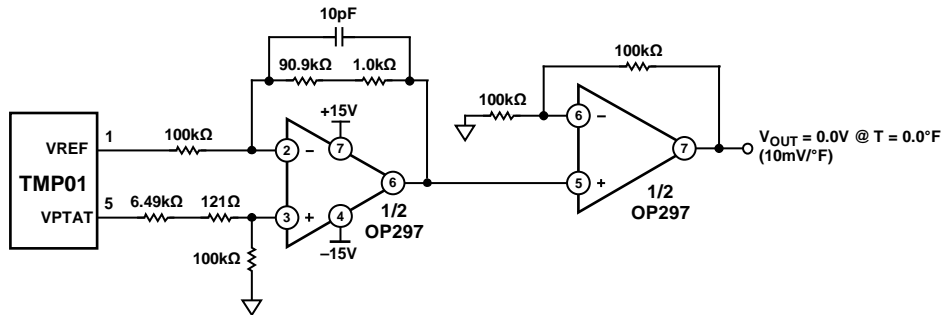
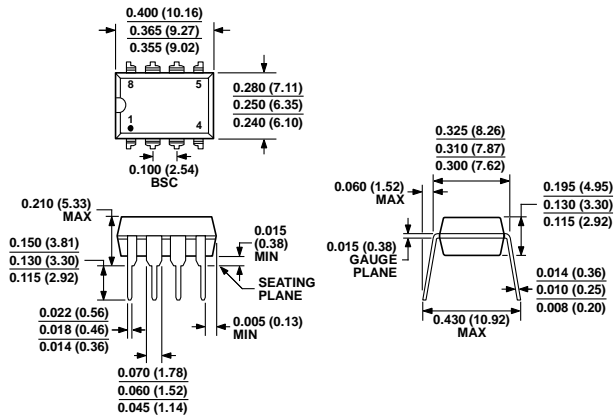

Figure 32. Translating 5 mV/K to 10 mV/°F

00333-032

OUTLINE DIMENSIONS



COMPLIANT TO JEDEC STANDARDS MS-001
 CONTROLLING DIMENSIONS ARE IN INCHES; MILLIMETER DIMENSIONS (IN PARENTHESES) ARE ROUNDED-OFF INCH EQUIVALENTS FOR REFERENCE ONLY AND ARE NOT APPROPRIATE FOR USE IN DESIGN. CORNER LEADS MAY BE CONFIGURED AS WHOLE OR HALF LEADS.

Figure 33. .8-Lead Plastic Dual In-Line Package [PDIP] Narrow Body (N-8)

Dimensions shown in inches and (millimeters)

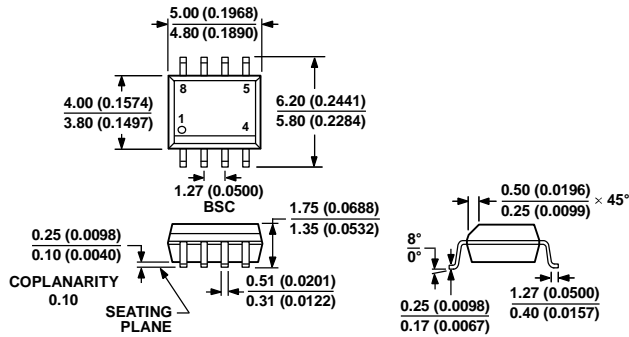

COMPLIANT TO JEDEC STANDARDS MS-012-AA
 CONTROLLING DIMENSIONS ARE IN MILLIMETERS; INCH DIMENSIONS (IN PARENTHESES) ARE ROUNDED-OFF MILLIMETER EQUIVALENTS FOR REFERENCE ONLY AND ARE NOT APPROPRIATE FOR USE IN DESIGN.

Figure 34. 8-Lead Standard Small Outline package [SOIC_N] Narrow Body (R-8)

Dimensions shown in millimeters and (inches)

TMP01

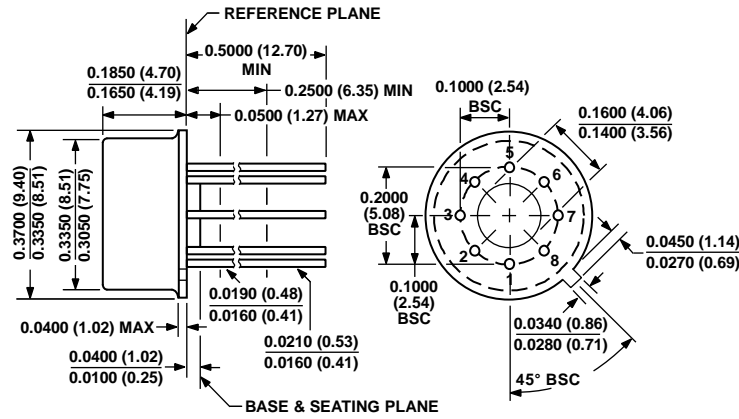

COMPLIANT TO JEDEC STANDARDS MO-002-AK
 CONTROLLING DIMENSIONS ARE IN INCHES; MILLIMETER DIMENSIONS
 (IN PARENTHESES) ARE ROUNDED-OFF INCH EQUIVALENTS FOR
 REFERENCE ONLY AND ARE NOT APPROPRIATE FOR USE IN DESIGN.

022306-A

Figure 35. 8-Pin Metal Header [TO-99]
 (H-08)

Dimensions shown in inches and (millimeters)

ORDERING GUIDE

Model/Grade	Temperature Range	Package Description	Package Option
TMP01ES	-40°C to +85°C	8-Lead SOIC_N	R-8
TMP01ES-REEL	-40°C to +85°C	8-Lead SOIC_N	R-8
TMP01ESZ ¹	-40°C to +85°C	8-Lead SOIC_N	R-8
TMP01ESZ-REEL ¹	-40°C to +85°C	8-Lead SOIC_N	R-8
TMP01FP	-40°C to +85°C	8-Lead PDIP	N-8
TMP01FPZ ¹	-40°C to +85°C	8-Lead PDIP	N-8
TMP01FS	-40°C to +85°C	8-Lead SOIC_N	R-8
TMP01FS-REEL	-40°C to +85°C	8-Lead SOIC_N	R-8
TMP01FS-REEL7	-40°C to +85°C	8-Lead SOIC_N	R-8
TMP01FSZ ¹	-40°C to +85°C	8-Lead SOIC_N	R-8
TMP01FSZ-REEL ¹	-40°C to +85°C	8-Lead SOIC_N	R-8
TMP01FSZ-REEL7 ¹	-40°C to +85°C	8-Lead SOIC_N	R-8
TMP01FJ	-40°C to +85°C	8-Pin Metal Header (TO-99)	H-08

¹ Z = RoHS Compliant Part.



NOTES

TMP01

NOTES

Looking for pricing, stock, or lifecycle information?

Click below to explore more details on WIN SOURCE:

-  [View TMP01FPZ on WIN SOURCE](#)
-  [Analog Devices Inc. Information](#)

Optimize Your Supply Chain with WIN SOURCE Solutions

-  Global Sourcing Solution
-  Obsolete Management
-  Cost Control Management
-  Shortage Management
-  Alternative Solution
-  Excess Inventory Management