



THE DATASHEET OF TPS1100PWR



TPS1100, TPS1100Y SINGLE P-CHANNEL ENHANCEMENT-MODE MOSFETS

SLVS078C – DECEMBER 1993 – REVISED AUGUST 1995

- Low $r_{DS(on)}$. . . 0.18 Ω Typ at $V_{GS} = -10$ V
- 3 V Compatible
- Requires No External V_{CC}
- TTL and CMOS Compatible Inputs
- $V_{GS(th)} = -1.5$ V Max
- Available in Ultrathin TSSOP Package (PW)
- ESD Protection Up to 2 kV Per MIL-STD-883C, Method 3015

description

The TPS1100 is a single P-channel enhancement-mode MOSFET. The device has been optimized for 3-V or 5-V power distribution in battery-powered systems by means of Texas Instruments LinBiCMOS™ process. With a maximum $V_{GS(th)}$ of -1.5 V and an I_{DSS} of only $0.5 \mu A$, the TPS1100 is the ideal high-side switch for low-voltage, portable battery-management systems where maximizing battery life is a primary concern. The low $r_{DS(on)}$ and excellent ac characteristics (rise time 10 ns typical) make the TPS1100 the logical choice for low-voltage switching applications such as power switches for pulse-width-modulated (PWM) controllers or motor/bridge drivers.

The ultrathin thin shrink small-outline package or TSSOP (PW) version with its smaller footprint and reduction in height fits in places where other P-channel MOSFETs cannot. The size advantage is especially important where board real estate is at a premium and height restrictions do not allow for a small-outline integrated circuit (SOIC) package.

D OR PW PACKAGE
(TOP VIEW)

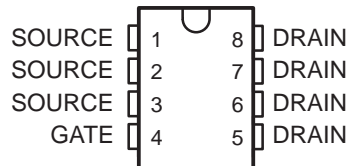

D PACKAGE

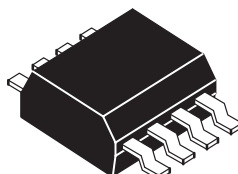

PW PACKAGE

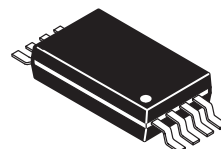

schematic

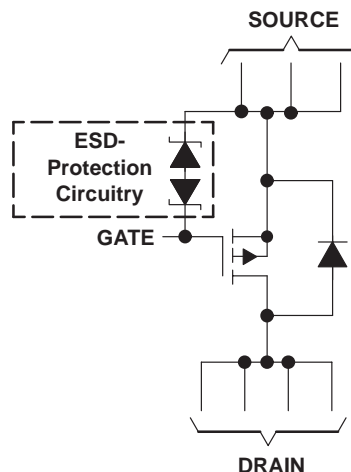

NOTE A: For all applications, all source pins should be connected and all drain pins should be connected.

AVAILABLE OPTIONS

T _A	PACKAGED DEVICES		CHIP FORM (Y)
	SMALL OUTLINE (D)	PLASTIC DIP (P)	
-40°C to 85°C	TPS1100D	TPS1100PWLE	TPS1100Y

The D package is available taped and reeled. Add an R suffix to device type (e.g., TPS1100DR). The PW package is available only left-end taped and reeled (indicated by the LE suffix on the device type; e.g., TPS1100PWLE). The chip form is tested at 25°C.



Caution. This device contains circuits to protect its inputs and outputs against damage due to high static voltages or electrostatic fields. These circuits have been qualified to protect this device against electrostatic discharges (ESD) of up to 2 kV according to MIL-STD-883C, Method 3015; however, it is advised that precautions be taken to avoid application of any voltage higher than maximum-rated voltages to these high-impedance circuits.

LinBiCMOS is a trademark of Texas Instruments Incorporated.

PRODUCTION DATA information is current as of publication date. Products conform to specifications per the terms of Texas Instruments standard warranty. Production processing does not necessarily include testing of all parameters.



POST OFFICE BOX 655303 • DALLAS, TEXAS 75265

Copyright © 1995, Texas Instruments Incorporated

TPS1100, TPS1100Y SINGLE P-CHANNEL ENHANCEMENT-MODE MOSFETS

SLVS078C – DECEMBER 1993 – REVISED AUGUST 1995

description (continued)

Such applications include notebook computers, personal digital assistants (PDAs), cellular telephones, and PCMCIA cards. For existing designs, the D-packaged version has a pinout common with other p-channel MOSFETs in SOIC packages.

TPS1100Y chip information

This chip, when properly assembled, displays characteristics similar to the TPS1100. Thermal compression or ultrasonic bonding may be used on the doped aluminum bonding pads. The chips may be mounted with conductive epoxy or a gold-silicon preform.

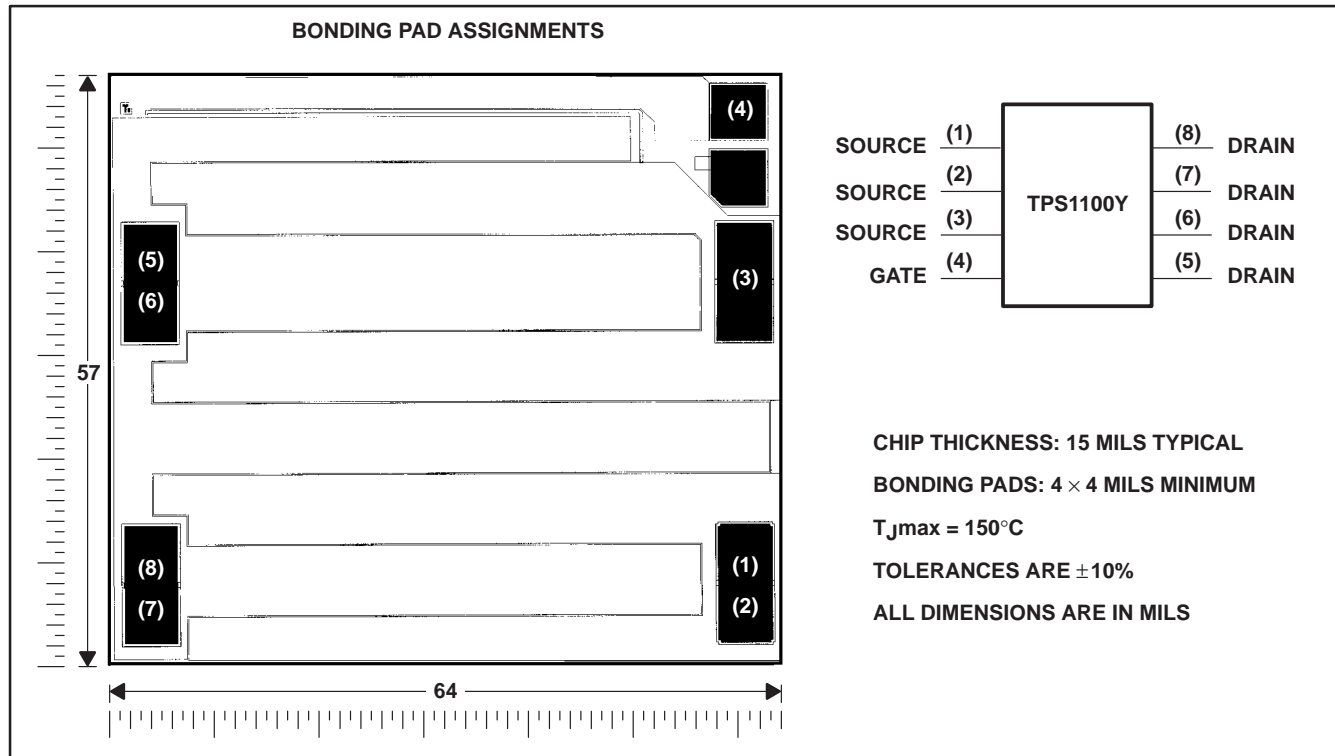

TPS1100, TPS1100Y

SINGLE P-CHANNEL ENHANCEMENT-MODE MOSFETS

SLVS078C – DECEMBER 1993 – REVISED AUGUST 1995

absolute maximum ratings over operating free-air temperature (unless otherwise noted)†

				UNIT	
Drain-to-source voltage, V_{DS}			-15	V	
Gate-to-source voltage, V_{GS}			2 or -15	V	
Continuous drain current ($T_J = 150^\circ\text{C}$), I_D^\ddagger	$V_{GS} = -2.7\text{ V}$	D package	$T_A = 25^\circ\text{C}$	± 0.41	A
			$T_A = 125^\circ\text{C}$	± 0.28	
		PW package	$T_A = 25^\circ\text{C}$	± 0.4	
			$T_A = 125^\circ\text{C}$	± 0.23	
	$V_{GS} = -3\text{ V}$	D package	$T_A = 25^\circ\text{C}$	± 0.6	
			$T_A = 125^\circ\text{C}$	± 0.33	
		PW package	$T_A = 25^\circ\text{C}$	± 0.53	
			$T_A = 125^\circ\text{C}$	± 0.27	
	$V_{GS} = -4.5\text{ V}$	D package	$T_A = 25^\circ\text{C}$	± 1	
			$T_A = 125^\circ\text{C}$	± 0.47	
		PW package	$T_A = 25^\circ\text{C}$	± 0.81	
			$T_A = 125^\circ\text{C}$	± 0.37	
$V_{GS} = -10\text{ V}$	D package	$T_A = 25^\circ\text{C}$	± 1.6		
		$T_A = 125^\circ\text{C}$	± 0.72		
	PW package	$T_A = 25^\circ\text{C}$	± 1.27		
		$T_A = 125^\circ\text{C}$	± 0.58		
Pulsed drain current, I_D^\ddagger			$T_A = 25^\circ\text{C}$	± 7	A
Continuous source current (diode conduction), I_S			$T_A = 25^\circ\text{C}$	-1	A
Storage temperature range, T_{stg}			-55 to 150	$^\circ\text{C}$	
Operating junction temperature range, T_J			-40 to 150	$^\circ\text{C}$	
Operating free-air temperature range, T_A			-40 to 125	$^\circ\text{C}$	
Lead temperature 1,6 mm (1/16 inch) from case for 10 seconds			260	$^\circ\text{C}$	

† Stresses beyond those listed under “absolute maximum ratings” may cause permanent damage to the device. These are stress ratings only, and functional operation of the device at these or any other conditions beyond those indicated under “recommended operating conditions” is not implied. Exposure to absolute-maximum-rated conditions for extended periods may affect device reliability.

‡ Maximum values are calculated using a derating factor based on $R_{\theta JA} = 158^\circ\text{C}/\text{W}$ for the D package and $R_{\theta JA} = 248^\circ\text{C}/\text{W}$ for the PW package. These devices are mounted on a FR4 board with no special thermal considerations.

DISSIPATION RATING TABLE

PACKAGE	$T_A \leq 25^\circ\text{C}$ POWER RATING	DERATING FACTOR‡ ABOVE $T_A = 25^\circ\text{C}$	$T_A = 70^\circ\text{C}$ POWER RATING	$T_A = 85^\circ\text{C}$ POWER RATING	$T_A = 125^\circ\text{C}$ POWER RATING
D	791 mW	6.33 mW/ $^\circ\text{C}$	506 mW	411 mW	158 mW
PW	504 mW	4.03 mW/ $^\circ\text{C}$	323 mW	262 mW	101 mW

‡ Maximum values are calculated using a derating factor based on $R_{\theta JA} = 158^\circ\text{C}/\text{W}$ for the D package and $R_{\theta JA} = 248^\circ\text{C}/\text{W}$ for the PW package. These devices are mounted on an FR4 board with no special thermal considerations when tested.

TPS1100, TPS1100Y SINGLE P-CHANNEL ENHANCEMENT-MODE MOSFETS

SLVS078C – DECEMBER 1993 – REVISED AUGUST 1995

electrical characteristics at $T_J = 25^\circ\text{C}$ (unless otherwise noted)

static

PARAMETER	TEST CONDITIONS	TPS1100			TPS1100Y			UNIT
		MIN	TYP	MAX	MIN	TYP	MAX	
$V_{GS(th)}$ Gate-to-source threshold voltage	$V_{DS} = V_{GS}, I_D = -250 \mu\text{A}$	-1	-1.25	-1.50	-1.25			V
V_{SD} Source-to-drain voltage (diode-forward voltage) [†]	$I_S = -1 \text{ A}, V_{GS} = 0 \text{ V}$		-0.9		-0.9			V
I_{GSS} Reverse gate current, drain short circuited to source	$V_{DS} = 0 \text{ V}, V_{GS} = -12 \text{ V}$			± 100				nA
I_{DSS} Zero-gate-voltage drain current	$V_{DS} = -12 \text{ V}, V_{GS} = 0 \text{ V}$	$T_J = 25^\circ\text{C}$		-0.5				μA
		$T_J = 125^\circ\text{C}$		-10				
$r_{DS(on)}$ Static drain-to-source on-state resistance [†]	$V_{GS} = -10 \text{ V}, I_D = -1.5 \text{ A}$		180		180			m Ω
	$V_{GS} = -4.5 \text{ V}, I_D = -0.5 \text{ A}$		291	400	291			
	$V_{GS} = -3 \text{ V}, I_D = -0.2 \text{ A}$		476	700	476			
	$V_{GS} = -2.7 \text{ V}, I_D = -0.2 \text{ A}$		606	850	606			
g_{fs} Forward transconductance [†]	$V_{DS} = -10 \text{ V}, I_D = -2 \text{ A}$		2.5		2.5			S

[†] Pulse test: pulse duration $\leq 300 \mu\text{s}$, duty cycle $\leq 2\%$

dynamic

PARAMETER	TEST CONDITIONS	TPS1100, TPS1100Y			UNIT
		MIN	TYP	MAX	
Q_g Total gate charge	$V_{DS} = -10 \text{ V}, V_{GS} = -10 \text{ V}, I_D = -1 \text{ A}$		5.45		nC
Q_{gs} Gate-to-source charge			0.87		
Q_{gd} Gate-to-drain charge			1.4		
$t_{d(on)}$ Turn-on delay time	$V_{DD} = -10 \text{ V}, R_L = 10 \Omega, I_D = -1 \text{ A}, R_G = 6 \Omega,$ See Figures 1 and 2		4.5		ns
$t_{d(off)}$ Turn-off delay time			13		ns
t_r Rise time			10		ns
t_f Fall time			2		
$t_{rr(SD)}$ Source-to-drain reverse recovery time	$I_F = 5.3 \text{ A}, di/dt = 100 \text{ A}/\mu\text{s}$		16		

PARAMETER MEASUREMENT INFORMATION

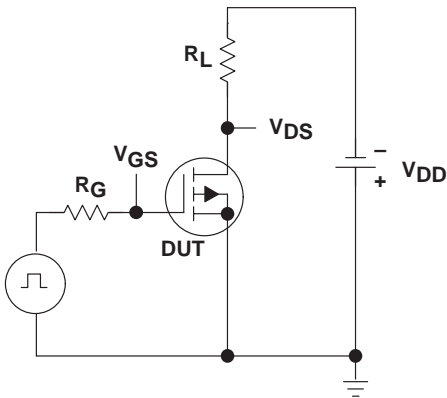

Figure 1. Switching-Time Test Circuit

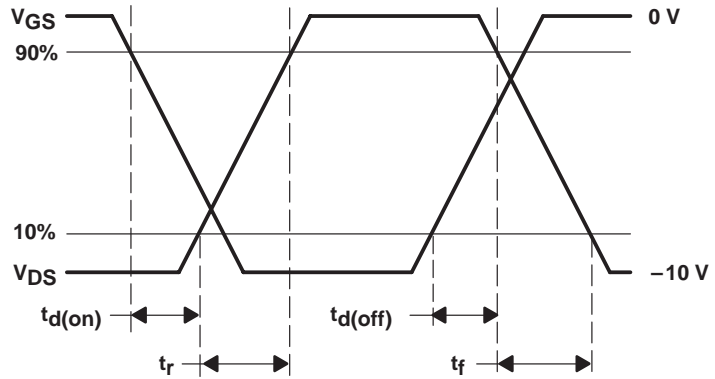

Figure 2. Switching-Time Waveforms

TYPICAL CHARACTERISTICS

Table of Graphs

		FIGURE
Drain current	vs Drain-to-source voltage	3
Drain current	vs Gate-to-source voltage	4
Static drain-to-source on-state resistance	vs Drain current	5
Capacitance	vs Drain-to-source voltage	6
Static drain-to-source on-state resistance (normalized)	vs Junction temperature	7
Source-to-drain diode current	vs Source-to-drain voltage	8
Static drain-to-source on-state resistance	vs Gate-to-source voltage	9
Gate-to-source threshold voltage	vs Junction temperature	10
Gate-to-source voltage	vs Gate charge	11

TPS1100, TPS1100Y SINGLE P-CHANNEL ENHANCEMENT-MODE MOSFETS

SLVS078C – DECEMBER 1993 – REVISED AUGUST 1995

TYPICAL CHARACTERISTICS

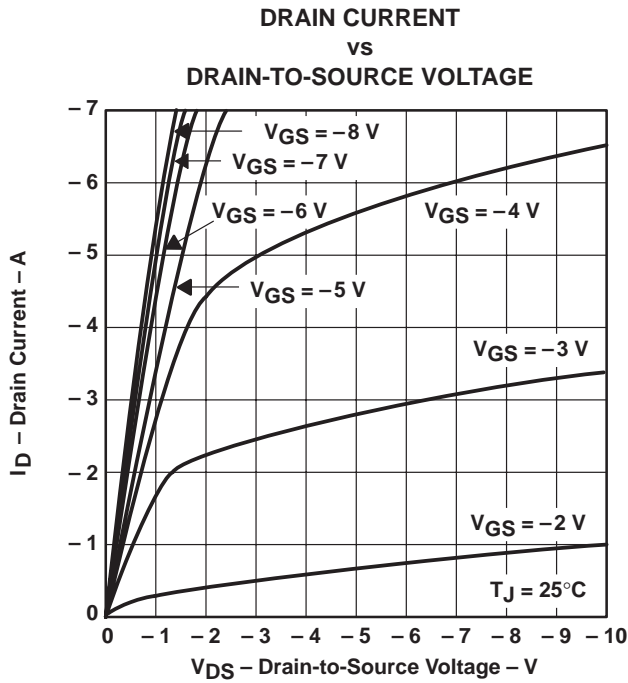

Figure 3

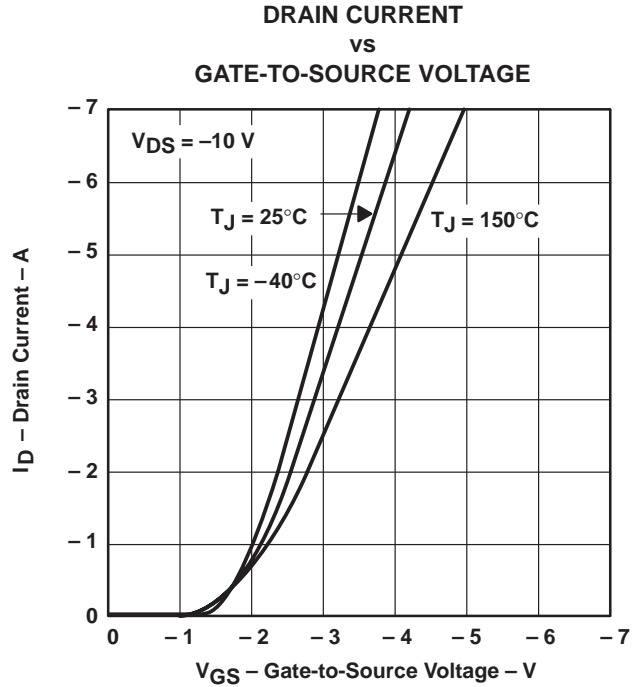

Figure 4

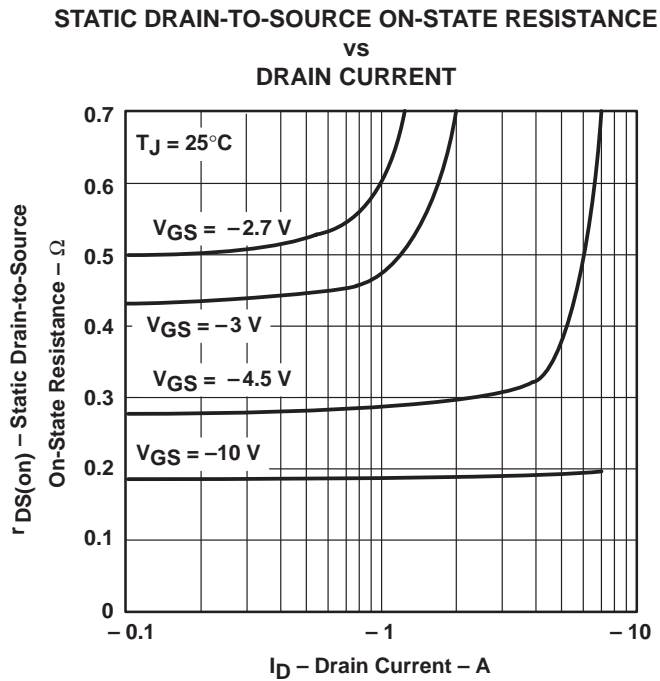
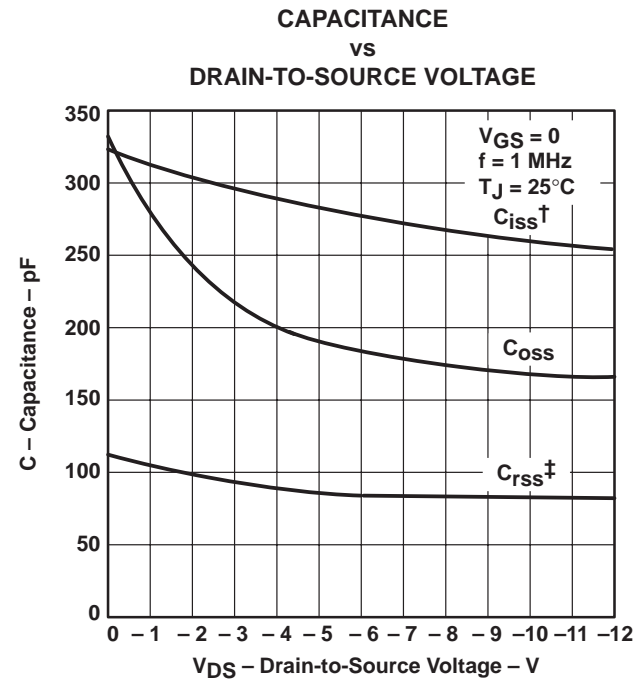

Figure 5



$$\dagger C_{iss} = C_{gs} + C_{gd} \cdot C_{ds(\text{shorted})}$$

$$\ddagger C_{rss} = C_{gd} \cdot C_{oss} = C_{ds} + \frac{C_{gs} C_{gd}}{C_{gs} + C_{gd}} \approx C_{ds} + C_{gd}$$

Figure 6



TYPICAL CHARACTERISTICS

STATIC DRAIN-TO-SOURCE
ON-STATE RESISTANCE (NORMALIZED)
vs
JUNCTION TEMPERATURE

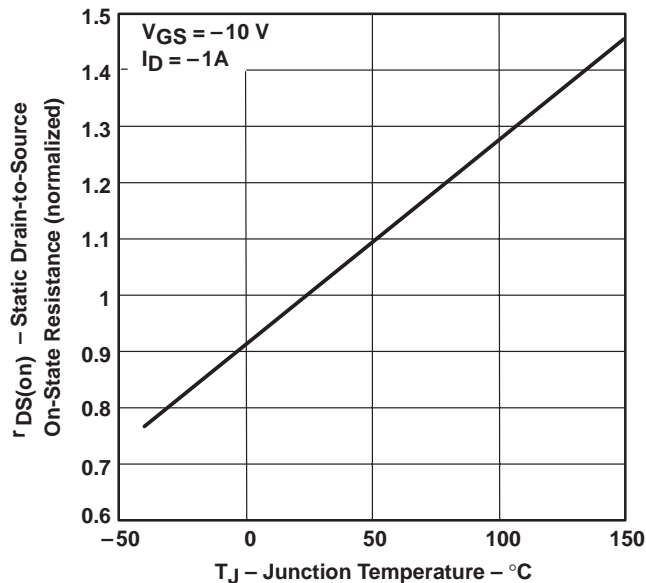

Figure 7

SOURCE-TO-DRAIN DIODE CURRENT
vs
SOURCE-TO-DRAIN VOLTAGE

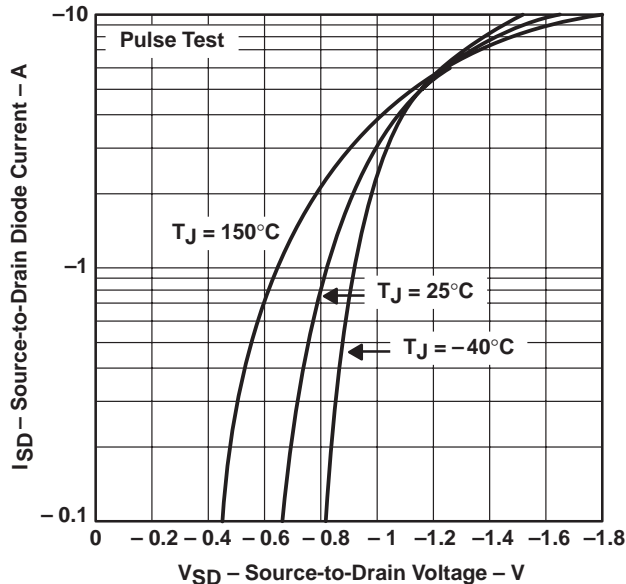

Figure 8

STATIC DRAIN-TO-SOURCE ON-STATE RESISTANCE
vs
GATE-TO-SOURCE VOLTAGE

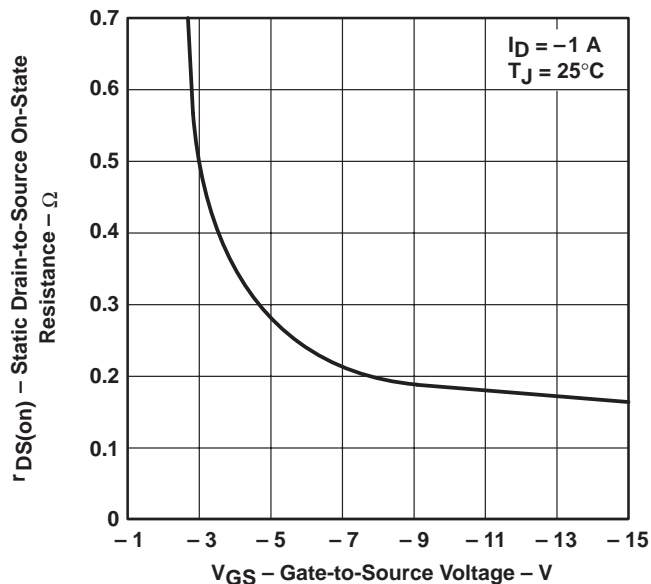

Figure 9

GATE-TO-SOURCE THRESHOLD VOLTAGE
vs
JUNCTION TEMPERATURE

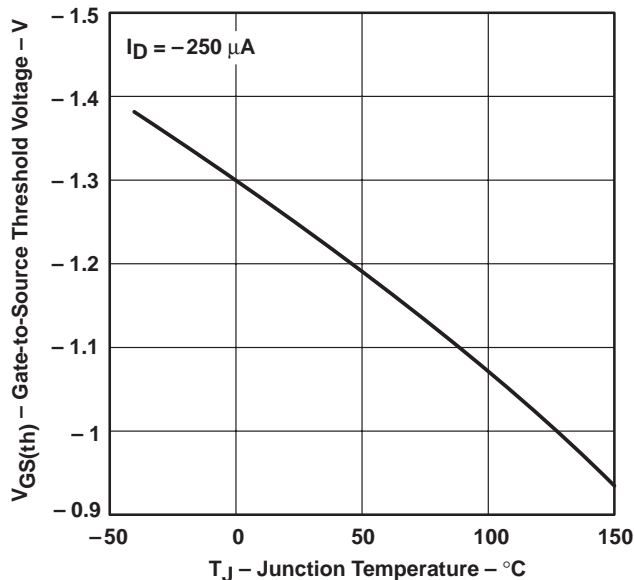

Figure 10

TPS1100, TPS1100Y SINGLE P-CHANNEL ENHANCEMENT-MODE MOSFETS

SLVS078C – DECEMBER 1993 – REVISED AUGUST 1995

TYPICAL CHARACTERISTICS

GATE-TO-SOURCE VOLTAGE
vs
GATE CHARGE

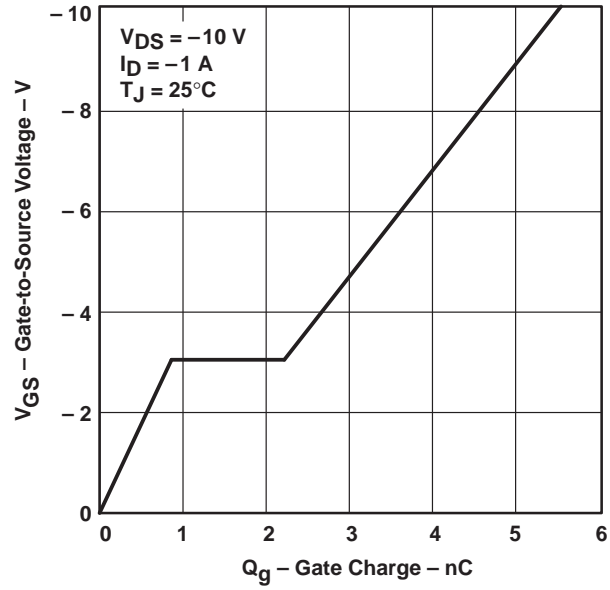
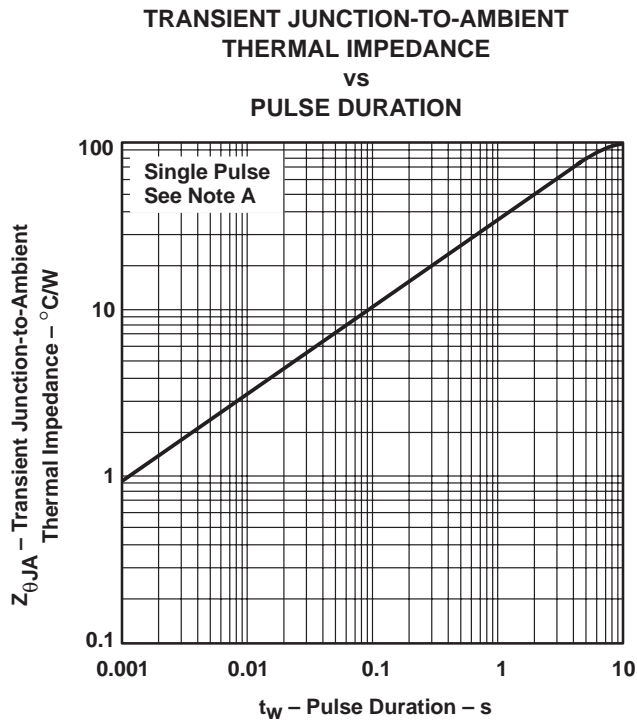
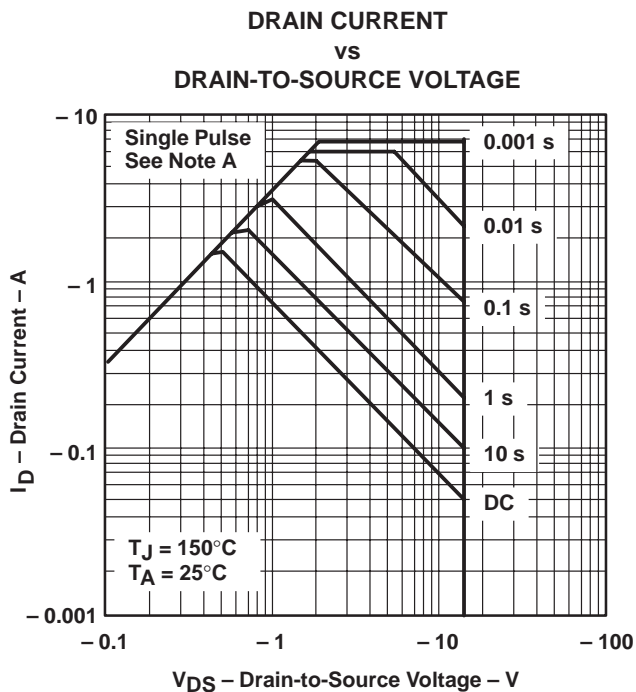

Figure 11

THERMAL INFORMATION



NOTE A: Values are for the D package and are FR4-board mounted only.

APPLICATION INFORMATION

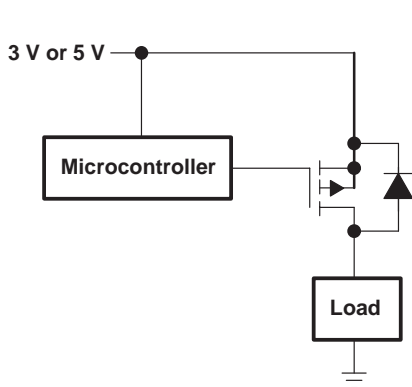

Figure 14. Notebook Load Management

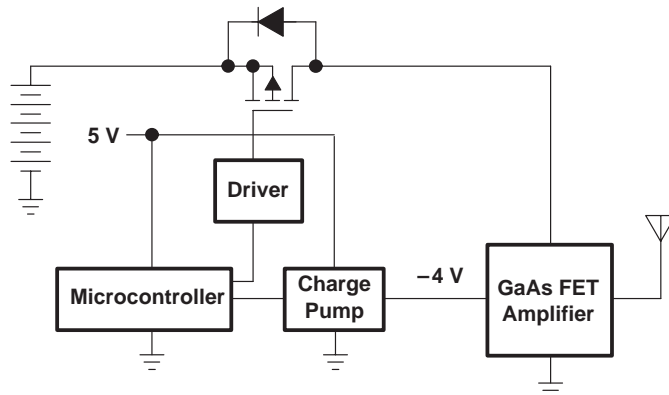

Figure 15. Cellular Phone Output Drive

PACKAGING INFORMATION

Orderable Device	Status (1)	Package Type	Package Drawing	Pins	Package Qty	Eco Plan (2)	Lead finish/ Ball material (6)	MSL Peak Temp (3)	Op Temp (°C)	Device Marking (4/5)	Samples
TPS1100D	ACTIVE	SOIC	D	8	75	RoHS & Green	NIPDAU	Level-1-260C-UNLIM		1100	Samples
TPS1100DR	ACTIVE	SOIC	D	8	2500	RoHS & Green	NIPDAU	Level-1-260C-UNLIM		1100	Samples
TPS1100PW	ACTIVE	TSSOP	PW	8	150	RoHS & Green	NIPDAU	Level-1-260C-UNLIM		PS1100	Samples
TPS1100PWR	ACTIVE	TSSOP	PW	8	2000	RoHS & Green	NIPDAU	Level-1-260C-UNLIM		PS1100	Samples

(1) The marketing status values are defined as follows:

ACTIVE: Product device recommended for new designs.

LIFEBUY: TI has announced that the device will be discontinued, and a lifetime-buy period is in effect.

NRND: Not recommended for new designs. Device is in production to support existing customers, but TI does not recommend using this part in a new design.

PREVIEW: Device has been announced but is not in production. Samples may or may not be available.

OBSELETE: TI has discontinued the production of the device.

(2) **RoHS:** TI defines "RoHS" to mean semiconductor products that are compliant with the current EU RoHS requirements for all 10 RoHS substances, including the requirement that RoHS substance do not exceed 0.1% by weight in homogeneous materials. Where designed to be soldered at high temperatures, "RoHS" products are suitable for use in specified lead-free processes. TI may reference these types of products as "Pb-Free".

RoHS Exempt: TI defines "RoHS Exempt" to mean products that contain lead but are compliant with EU RoHS pursuant to a specific EU RoHS exemption.

Green: TI defines "Green" to mean the content of Chlorine (Cl) and Bromine (Br) based flame retardants meet JS709B low halogen requirements of <=1000ppm threshold. Antimony trioxide based flame retardants must also meet the <=1000ppm threshold requirement.

(3) MSL, Peak Temp. - The Moisture Sensitivity Level rating according to the JEDEC industry standard classifications, and peak solder temperature.

(4) There may be additional marking, which relates to the logo, the lot trace code information, or the environmental category on the device.

(5) Multiple Device Markings will be inside parentheses. Only one Device Marking contained in parentheses and separated by a "-" will appear on a device. If a line is indented then it is a continuation of the previous line and the two combined represent the entire Device Marking for that device.

(6) Lead finish/Ball material - Orderable Devices may have multiple material finish options. Finish options are separated by a vertical ruled line. Lead finish/Ball material values may wrap to two lines if the finish value exceeds the maximum column width.

Important Information and Disclaimer:The information provided on this page represents TI's knowledge and belief as of the date that it is provided. TI bases its knowledge and belief on information provided by third parties, and makes no representation or warranty as to the accuracy of such information. Efforts are underway to better integrate information from third parties. TI has taken and

continues to take reasonable steps to provide representative and accurate information but may not have conducted destructive testing or chemical analysis on incoming materials and chemicals. TI and TI suppliers consider certain information to be proprietary, and thus CAS numbers and other limited information may not be available for release.

In no event shall TI's liability arising out of such information exceed the total purchase price of the TI part(s) at issue in this document sold by TI to Customer on an annual basis.

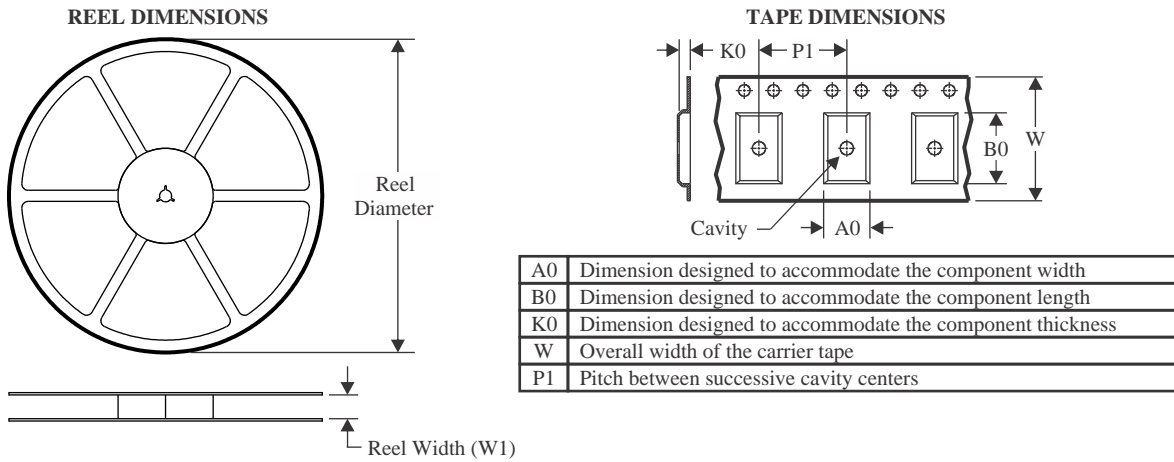
TAPE AND REEL INFORMATION

QUADRANT ASSIGNMENTS FOR PIN 1 ORIENTATION IN TAPE

*All dimensions are nominal

Device	Package Type	Package Drawing	Pins	SPQ	Reel Diameter (mm)	Reel Width W1 (mm)	A0 (mm)	B0 (mm)	K0 (mm)	P1 (mm)	W (mm)	Pin1 Quadrant
TPS1100DR	SOIC	D	8	2500	330.0	12.4	6.4	5.2	2.1	8.0	12.0	Q1
TPS1100PWR	TSSOP	PW	8	2000	330.0	12.4	7.0	3.6	1.6	8.0	12.0	Q1

TAPE AND REEL BOX DIMENSIONS

*All dimensions are nominal

Device	Package Type	Package Drawing	Pins	SPQ	Length (mm)	Width (mm)	Height (mm)
TPS1100DR	SOIC	D	8	2500	340.5	338.1	20.6
TPS1100PWR	TSSOP	PW	8	2000	356.0	356.0	35.0

TUBE

*All dimensions are nominal

Device	Package Name	Package Type	Pins	SPQ	L (mm)	W (mm)	T (μm)	B (mm)
TPS1100D	D	SOIC	8	75	507	8	3940	4.32
TPS1100PW	PW	TSSOP	8	150	530	10.2	3600	3.5

IMPORTANT NOTICE AND DISCLAIMER

TI PROVIDES TECHNICAL AND RELIABILITY DATA (INCLUDING DATA SHEETS), DESIGN RESOURCES (INCLUDING REFERENCE DESIGNS), APPLICATION OR OTHER DESIGN ADVICE, WEB TOOLS, SAFETY INFORMATION, AND OTHER RESOURCES "AS IS" AND WITH ALL FAULTS, AND DISCLAIMS ALL WARRANTIES, EXPRESS AND IMPLIED, INCLUDING WITHOUT LIMITATION ANY IMPLIED WARRANTIES OF MERCHANTABILITY, FITNESS FOR A PARTICULAR PURPOSE OR NON-INFRINGEMENT OF THIRD PARTY INTELLECTUAL PROPERTY RIGHTS.

These resources are intended for skilled developers designing with TI products. You are solely responsible for (1) selecting the appropriate TI products for your application, (2) designing, validating and testing your application, and (3) ensuring your application meets applicable standards, and any other safety, security, regulatory or other requirements.

These resources are subject to change without notice. TI grants you permission to use these resources only for development of an application that uses the TI products described in the resource. Other reproduction and display of these resources is prohibited. No license is granted to any other TI intellectual property right or to any third party intellectual property right. TI disclaims responsibility for, and you will fully indemnify TI and its representatives against, any claims, damages, costs, losses, and liabilities arising out of your use of these resources.

TI's products are provided subject to [TI's Terms of Sale](#) or other applicable terms available either on [ti.com](https://www.ti.com) or provided in conjunction with such TI products. TI's provision of these resources does not expand or otherwise alter TI's applicable warranties or warranty disclaimers for TI products.

TI objects to and rejects any additional or different terms you may have proposed.

Mailing Address: Texas Instruments, Post Office Box 655303, Dallas, Texas 75265
Copyright © 2023, Texas Instruments Incorporated

Looking for pricing, stock, or lifecycle information?

Click below to explore more details on WIN SOURCE:

 [View TPS1100PWR](#) on WIN SOURCE

 [Texas Instruments](#) Information

Optimize Your Supply Chain with WIN SOURCE Solutions

-  Global Sourcing Solution
-  Obsolete Management
-  Cost Control Management
-  Shortage Management
-  Alternative Solution
-  Excess Inventory Management