

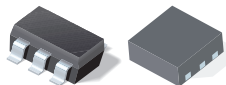

THE DATASHEET OF TPS2551DRVT





ADJUSTABLE CURRENT-LIMITED POWER-DISTRIBUTION SWITCHES

FEATURES

- Adjustable Current-Limit, 100 mA–1100 mA
- Fast Overcurrent Response - 2 μ S Typical
- 85-m Ω High-Side MOSFET (DBV Package)
- Reverse Input-Output Voltage Protection
- Operating Range: 2.5 V to 6.5 V
- Deglitched Fault Report
- 1- μ A Maximum Standby Supply Current
- Junction Temperature Range: -40°C to 125°C
- Built-in Soft-Start
- 15 kV ESD Protection (with external capacitance)
- UL Listed – File No. E169910
- Current-Limit Resistor Calculator – [SLVC163](#)

APPLICATIONS

- USB Ports/Hubs
- Cell phones
- Laptops
- Heavy Capacitive Loads
- Reverse-Voltage Protection

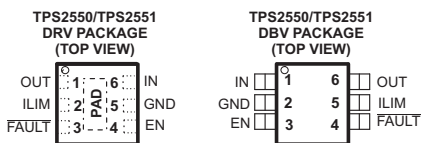

EN = Active Low for the TPS2550
EN = Active High for the TPS2551

DESCRIPTION

The TPS2550/51 power-distribution switch is intended for applications where heavy capacitive loads and short-circuits are likely to be encountered, incorporating a 100-m Ω , N-channel MOSFET in a single package. The current-limit threshold is user adjustable between 100 mA and 1.1 A via an external resistor. The power-switch rise and fall times are controlled to minimize current surges during switching.

The device limits the output current to a desired level by switching into a constant-current mode when the output load exceeds the current-limit threshold or a short is present. An internal reverse-voltage detection comparator disables the power-switch in the event that the output voltage is driven higher than the input to protect devices on the input side of the switch. The FAULT logic output asserts low during both overcurrent and reverse-voltage conditions.

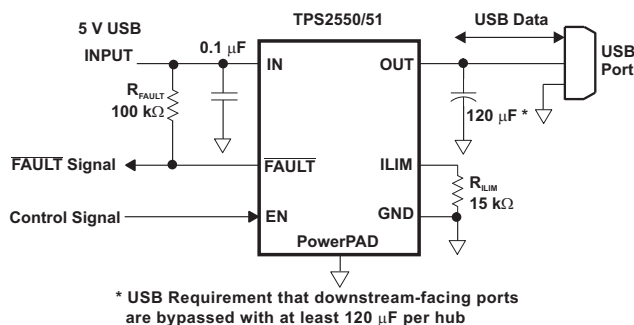

Figure 1. Typical Application as USB Power Switch

GENERAL SWITCH CATALOG						
33 m Ω , Single	80 m Ω , Single	80 m Ω , Dual	80 m Ω , Dual	80 m Ω , Triple	80 m Ω , Quad	80 m Ω , Quad
 TPS201xA 0.2 A to 2 A TPS202x 0.2 A to 2 A TPS203x 0.2 A to 2 A	 TPS2014 600 mA TPS2015 1 A TPS2041B 500 mA TPS2051B 500 mA TPS2045A 250 mA TPS2049 100 mA TPS2055A 250 mA TPS2061 1 A TPS2065 1 A TPS2068 1.5 A TPS2069 1.5 A	 TPS2042B 500 mA TPS2052B 500 mA TPS2046B 250 mA TPS2056 250 mA TPS2062 1 A TPS2066 1 A TPS2060 1.5 A TPS2064 1.5 A	 TPS2080 500 mA TPS2081 500 mA TPS2082 500 mA TPS2090 250 mA TPS2091 250 mA TPS2092 250 mA	 TPS2043B 500 mA TPS2053B 500 mA TPS2047B 250 mA TPS2057A 250 mA TPS2063 1 A TPS2067 1 A	 TPS2044B 500 mA TPS2054B 500 mA TPS2048A 250 mA TPS2058 250 mA	 TPS2085 500 mA TPS2086 500 mA TPS2087 500 mA TPS2095 250 mA TPS2096 250 mA TPS2097 250 mA



Please be aware that an important notice concerning availability, standard warranty, and use in critical applications of Texas Instruments semiconductor products and disclaimers thereto appears at the end of this data sheet.

PowerPAD is a trademark of Texas Instruments.



This device contains circuits to protect its inputs and outputs against damage due to high static voltages or electrostatic fields. These circuits have been qualified to protect this device against electrostatic discharges (ESD) of up to 2 kV according to MIL-STD-883C, Method 3015; however, it is advised that precautions be taken to avoid application of any voltage higher than maximum-rated voltages to these high-impedance circuits. During storage or handling the device leads should be shorted together or the device should be placed in conductive foam. In a circuit, unused inputs should always be connected to an appropriate logic voltage level, preferably either VCC or ground. Specific guidelines for handling devices of this type are contained in the publication Guidelines for Handling Electrostatic-Discharge-Sensitive (ESDS) Devices and Assemblies available from Texas Instruments.

AVAILABLE OPTIONS AND ORDERING INFORMATION

DEVICE	AMBIENT TEMPERATURE ⁽¹⁾	ENABLE	SON ⁽²⁾ (DRV)	SOT23 ⁽²⁾ (DBV)	RECOMMENDED MAXIMUM CONTINUOUS LOAD CURRENT
TPS2550	-40°C to 85°C	Active low	TPS2550DRV	TPS2550DBV	1.1 A
TPS2551		Active high	TPS2551DRV	TPS2551DBV	1.1 A

- (1) Maximum ambient temperature is a function of device junction temperature and system level considerations, such as power dissipation and board layout. See *dissipation rating table* and *recommended operating conditions* for specific information related to these devices.
 (2) Add an R suffix to the device type for tape and reel.

ABSOLUTE MAXIMUM RATINGS

over operating free-air temperature range unless otherwise noted^{(1) (2)}

	VALUE	UNIT
Voltage range on IN, OUT, EN or $\overline{\text{EN}}$, ILIM, $\overline{\text{FAULT}}$	-0.3 to 7	V
Voltage range from IN to OUT	-7 to 7	V
I_{OUT} Continuous output current	Internally limited	
Continuous total power dissipation	See "Dissipation Rating Table"	
$\overline{\text{FAULT}}$ sink current	25	mA
ILIM source current	1	mA
ESD	HBM	2
	CDM	500
T_{J} Maximum junction temperature	-40 to 150	°C
T_{Sgt} Storage temperature	-65 to 150	°C
Lead temperature 1,6 mm (1/16-inch) from case for 10 seconds	300	°C

- (1) Stresses beyond those listed under *absolute maximum ratings* may cause permanent damage to the device. These are stress ratings only, and functional operation of the device at these or any other conditions beyond those indicated under *recommended operating conditions* is not implied. Exposure to absolute-maximum-rated conditions for extended periods may affect device reliability.
 (2) Voltages are referenced to GND unless otherwise noted.

DISSIPATION RATING TABLE

BOARD	PACKAGE	THERMAL RESISTANCE θ_{JA}	THERMAL RESISTANCE θ_{JC}	$T_{\text{A}} \leq 25^{\circ}\text{C}$ POWER RATING	DERATING FACTOR ABOVE $T_{\text{A}} = 25^{\circ}\text{C}$	$T_{\text{A}} = 70^{\circ}\text{C}$ POWER RATING	$T_{\text{A}} = 85^{\circ}\text{C}$ POWER RATING	$T_{\text{A}} = 110^{\circ}\text{C}$ POWER RATING
Low-K ⁽¹⁾	DBV	350°C/W	55°C/W	285 mW	2.85 mW/°C	155 mW	114 mW	42 mW
High-K ⁽²⁾	DBV	160°C/W	55°C/W	625 mW	6.25 mW/°C	340 mW	250 mW	93 mW
Low-K ⁽¹⁾	DRV	140°C/W	20°C/W	715 mW	7.1 mW/°C	395 mW	285 mW	107 mW
High-K ⁽²⁾	DRV	75°C/W	20°C/W	1330 mW	13.3 mW/°C	730 mW	530 mW	200 mW

- (1) The JEDEC low-K (1s) board used to derive this data was a 3in x 3in, two-layer board with 2-ounce copper traces on top of the board.
 (2) The JEDEC high-K (2s2p) board used to derive this data was a 3in x 3in, multilayer board with 1-ounce internal power and ground planes and 2-ounce copper traces on top and bottom of the board.

RECOMMENDED OPERATING CONDITIONS

			MIN	MAX	UNIT
V_{IN}	Input voltage, IN		2.5	6.5	V
V_{EN}	Enable voltage	TPS2550	0	6.5	V
$V_{\overline{EN}}$		TPS2551	0	6.5	
I_{OUT}	Continuous output current, OUT		0	1.1	A
R_{ILIM}	Current-limit set resistor from ILIM to GND		14.3	80.6	k Ω
$I_{\overline{FAULT}}$	\overline{FAULT} sink current		0	10	mA
T_J	Operating virtual junction temperature	DRV & DBV	-40	125	$^{\circ}\text{C}$

ELECTRICAL CHARACTERISTICS

over recommended operating junction temperature range, $2.5\text{ V} \leq V_{IN} \leq 6.5\text{ V}$, $R_{ILIM} = 14.3\text{ k}\Omega$, $V_{\overline{EN}} = 0\text{ V}$, or $V_{EN} = 5.0\text{ V}$ (unless otherwise noted)

PARAMETER		TEST CONDITIONS ⁽¹⁾	MIN	TYP	MAX	UNIT
POWER SWITCH						
$r_{DS(on)}$	Static drain-source on-state resistance	DBV package, $T_J = 25\text{ }^{\circ}\text{C}$		85	95	m Ω
		DBV package, $-40\text{ }^{\circ}\text{C} \leq T_J \leq 125\text{ }^{\circ}\text{C}$			135	
		DRV package, $T_J = 25\text{ }^{\circ}\text{C}$		100	115	
		DRV package, $-40\text{ }^{\circ}\text{C} \leq T_J \leq 105\text{ }^{\circ}\text{C}$			145	
		DRV package, $-40\text{ }^{\circ}\text{C} \leq T_J \leq 125\text{ }^{\circ}\text{C}$			150	
t_r	Rise time, output	$V_{IN} = 6.5\text{ V}$	$C_L = 1\text{ }\mu\text{F}$, $R_L = 100\text{ }\Omega$, (see Figure 2)	1.0	1.5	ms
		$V_{IN} = 2.5\text{ V}$		0.65	1.0	
t_f	Fall time, output	$V_{IN} = 6.5\text{ V}$		0.2	0.5	
		$V_{IN} = 2.5\text{ V}$		0.2	0.5	
ENABLE INPUT EN OR \overline{EN}						
V_{IH}	High-level input voltage		1.1			V
V_{IL}	Low-level input voltage				0.66	
I_{EN}	Input current	$V_{EN} = 0\text{ V}$ or 6.5 V , $V_{\overline{EN}} = 0\text{ V}$ or 6.5 V	-0.5		0.5	μA
t_{on}	Turnon time	$C_L = 1\text{ }\mu\text{F}$, $R_L = 100\text{ }\Omega$, (see Figure 2)			3	ms
t_{off}	Turnoff time				3	ms
CURRENT LIMIT						
I_{OS}	Short-circuit current, OUT connected to GND	$R_{ILIM} = 80.6\text{ k}\Omega$	110	215	300	mA
		$R_{ILIM} = 38.3\text{ k}\Omega$	300	500	650	
		$R_{ILIM} = 15\text{ k}\Omega$	1050	1400	1650	
I_{OC}	Current-limit threshold (Maximum DC output current I_{OUT} delivered to load)	$R_{ILIM} = 80.6\text{ k}\Omega$	290	315	340	
		$R_{ILIM} = 38.3\text{ k}\Omega$	620	665	705	
		$R_{ILIM} = 15\text{ k}\Omega$	1550	1650	1750	
t_{IOS}	Response time to short circuit	$V_{IN} = 5.0\text{ V}$ (see Figure 3)		2		μs
REVERSE-VOLTAGE PROTECTION						
	Reverse-voltage comparator trip point ($V_{OUT} - V_{IN}$)		95	135	190	mV
	Time from reverse-voltage condition to MOSFET turn off	$V_{IN} = 5.0\text{ V}$	3	5	7	ms
SUPPLY CURRENT						
I_{IN_off}	Supply current, low-level output	$V_{IN} = 6.5\text{ V}$, No load on OUT, $V_{\overline{EN}} = 6.5\text{ V}$ or $V_{EN} = 0\text{ V}$, $14.3\text{ k}\Omega \leq R_{ILIM} \leq 80.6\text{ k}\Omega$		0.1	1	μA
I_{IN_on}	Supply current, high-level output	$V_{IN} = 6.5\text{ V}$, No load on OUT, $V_{\overline{EN}} = 0\text{ V}$ or $V_{EN} = 6.5\text{ V}$	$R_{ILIM} = 15\text{ k}\Omega$		150	μA
			$R_{ILIM} = 80.6\text{ k}\Omega$		130	μA
I_{REV}	Reverse leakage current	$V_{OUT} = 6.5\text{ V}$, $V_{IN} = 0\text{ V}$		0.01	1	μA

(1) Pulse-testing techniques maintain junction temperature close to ambient temperature; thermal effects must be taken into account separately.

ELECTRICAL CHARACTERISTICS (continued)

over recommended operating junction temperature range, $2.5\text{ V} \leq V_{IN} \leq 6.5\text{ V}$, $R_{ILIM} = 14.3\text{ k}\Omega$, $V_{EN} = 0\text{ V}$, or $V_{EN} = 5.0\text{ V}$ (unless otherwise noted)

PARAMETER		TEST CONDITIONS ⁽¹⁾	MIN	TYP	MAX	UNIT
UNDERVOLTAGE LOCKOUT						
V_{UVLO}	Low-level input voltage, IN	V_{IN} rising		2.35	2.45	V
	Hysteresis, IN	$T_J = 25\text{ }^\circ\text{C}$		25		mV
FAULT FLAG						
V_{OL}	Output low voltage, $\overline{\text{FAULT}}$	$I_{\text{FAULT}} = 1\text{ mA}$			180	mV
	Off-state leakage	$V_{\text{FAULT}} = 6.5\text{ V}$			1	μA
	$\overline{\text{FAULT}}$ deglitch	$\overline{\text{FAULT}}$ assertion or de-assertion due to overcurrent condition	5	7.5	10	ms
		$\overline{\text{FAULT}}$ assertion or de-assertion due to reverse-voltage condition	2	4	6	ms
THERMAL SHUTDOWN						
	Thermal shutdown threshold		155			$^\circ\text{C}$
	Thermal shutdown threshold in current-limit		135			$^\circ\text{C}$
	Hysteresis			15		$^\circ\text{C}$

DEVICE INFORMATION

Terminal Functions

NAME	TERMINAL				I/O	DESCRIPTION
	TPS2550DBV	TPS2551DBV	TPS2550DRV	TPS2551DRV		
$\overline{\text{EN}}$	3	—	4	—	I	Enable input, logic low turns on power switch
EN	—	3	—	4	I	Enable input, logic high turns on power switch
GND	2	2	5	5		Ground connection; should be connected externally to POWER PAD
IN	1	1	6	6	I	Input voltage; connect a 0.1 μF or greater ceramic capacitor from IN to GND as close to the IC as possible.
$\overline{\text{FAULT}}$	4	4	3	3	O	Active-low open-drain output, asserted during overcurrent, overtemperature, or reverse-voltage conditions.
OUT	6	6	1	1	O	Power-switch output
ILIM	5	5	2	2	I	External resistor used to set current-limit threshold; recommended $14.3 \text{ k}\Omega \leq R_{\text{ILIM}} \leq 80.6 \text{ k}\Omega$.
PowerPAD™	—	—	PAD	PAD		Internally connected to GND; used to heat-sink the part to the circuit board traces. Should be connected to GND pin.

FUNCTIONAL BLOCK DIAGRAM

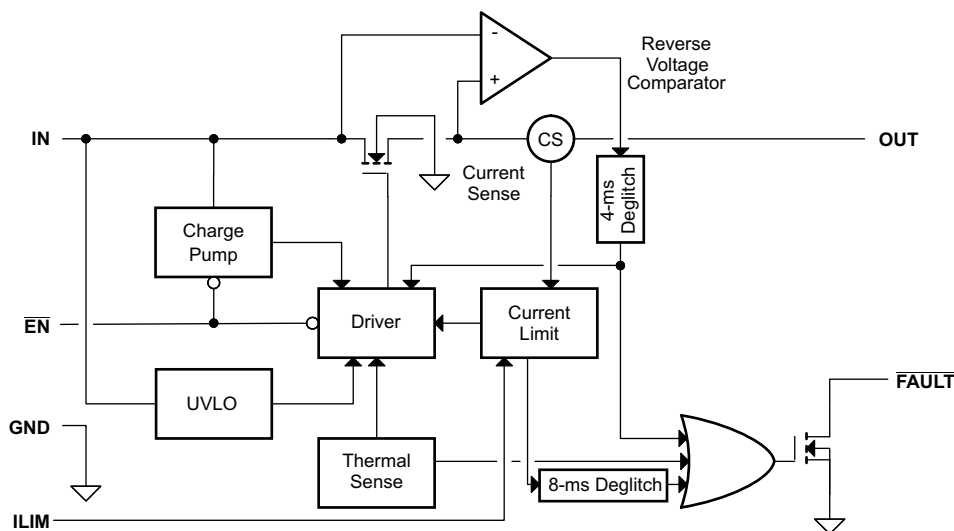

PARAMETER MEASUREMENT INFORMATION

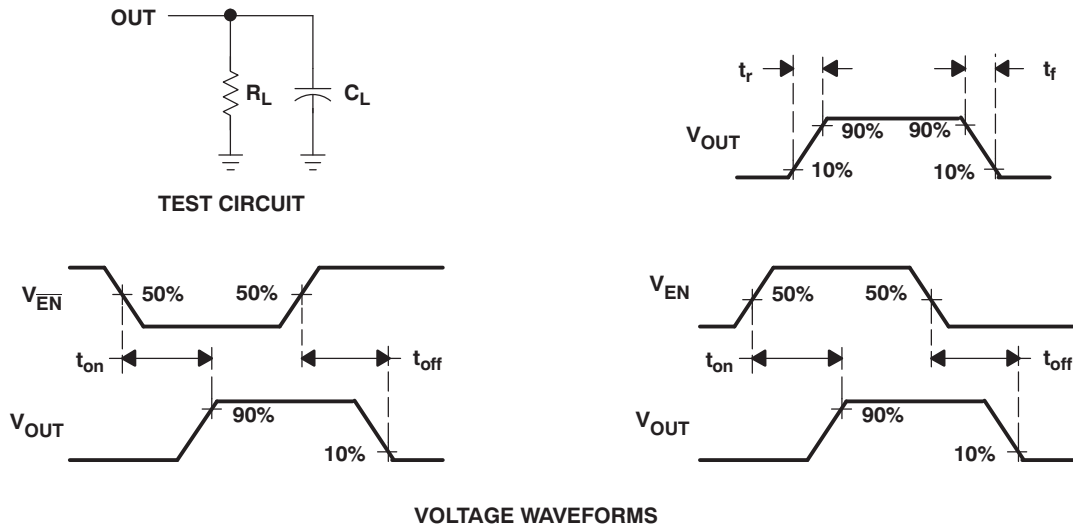

Figure 2. Test Circuit and Voltage Waveforms

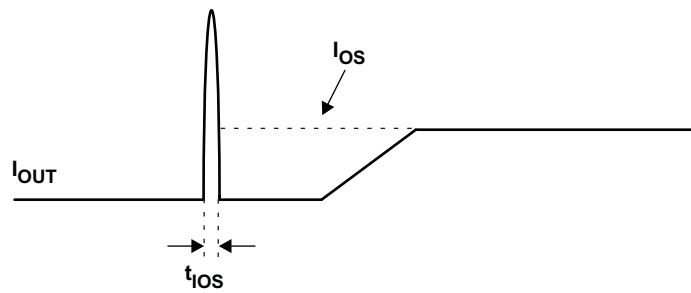

Figure 3. Response Time to Short-Circuit Waveform

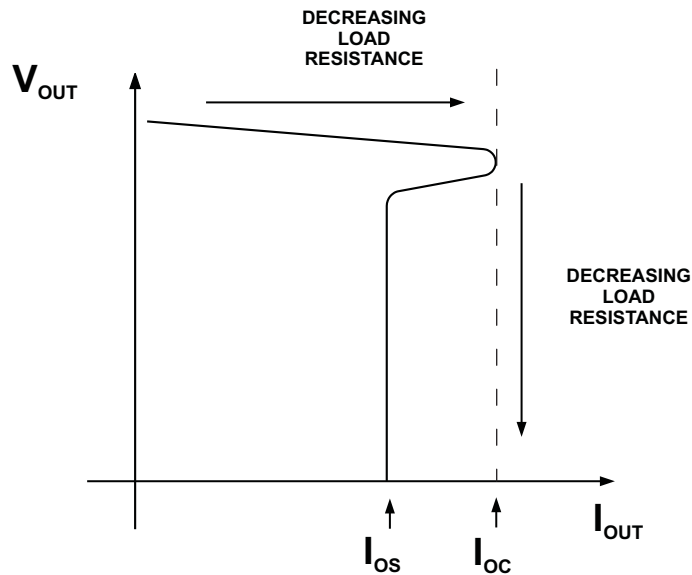

Figure 4. Output Voltage vs. Current-Limit Threshold

TYPICAL CHARACTERISTICS

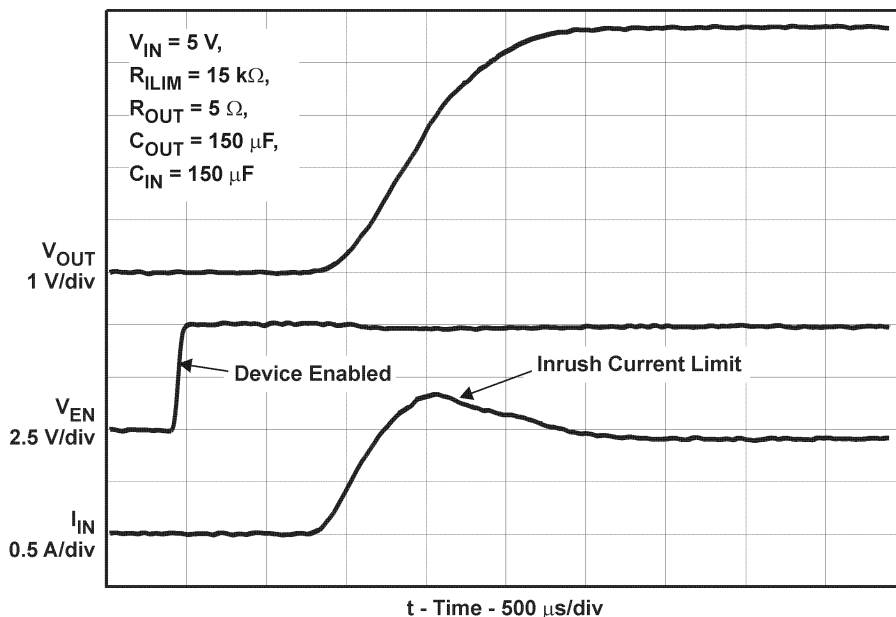

Figure 5. Turnon Delay and Rise Time

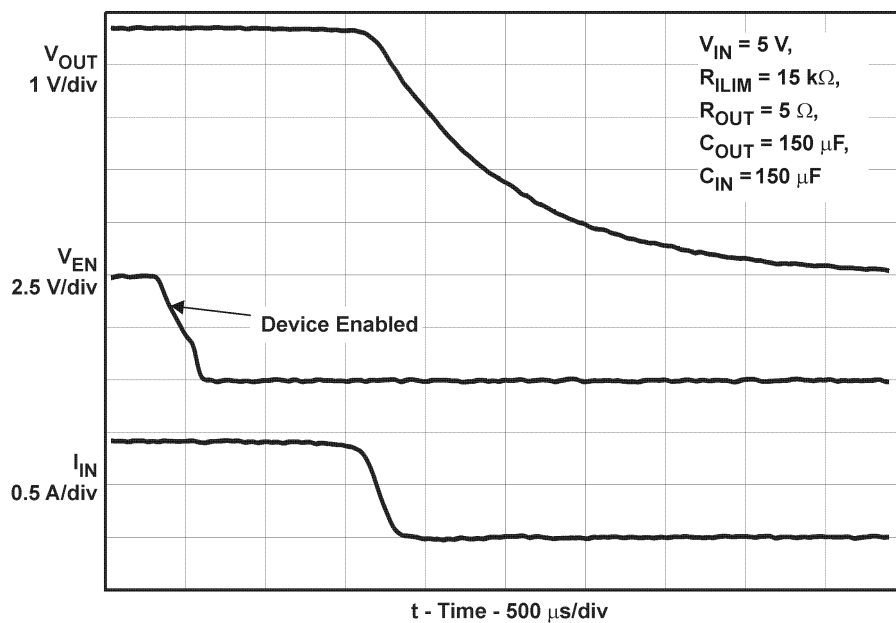

Figure 6. Turnoff Delay and Fall Time

TYPICAL CHARACTERISTICS (continued)

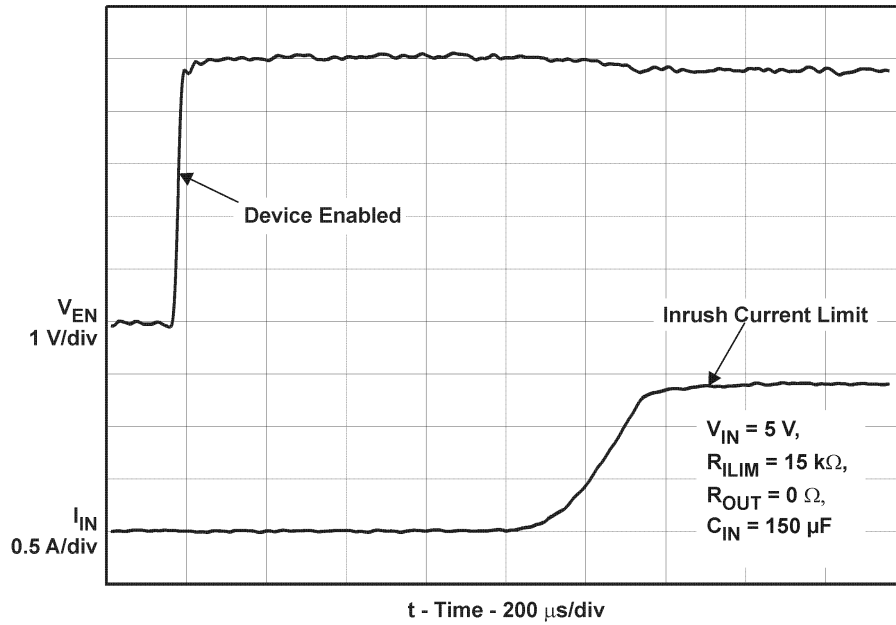

Figure 7. Device Enabled into Short-Circuit

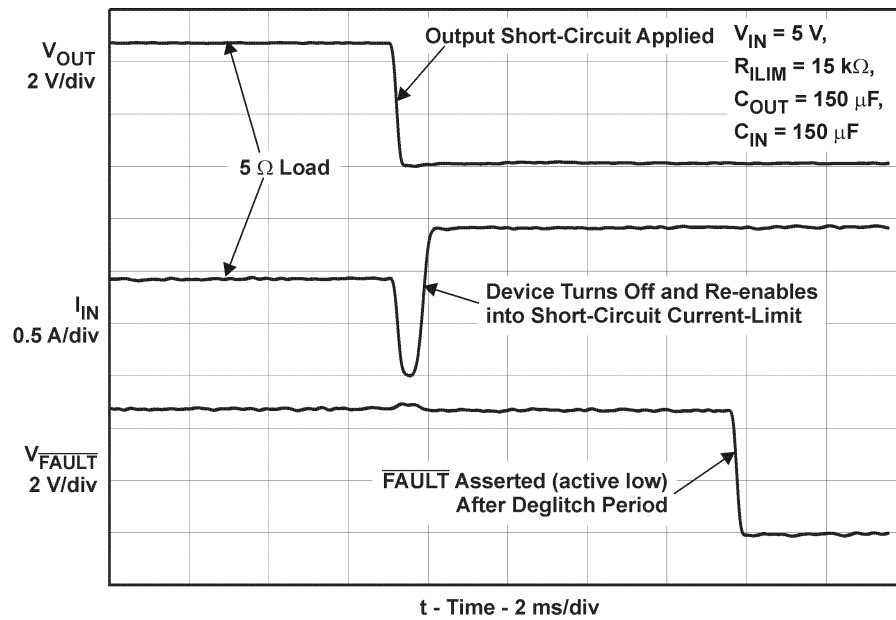

Figure 8. Full-Load to Short-Circuit Transient Response

TYPICAL CHARACTERISTICS (continued)

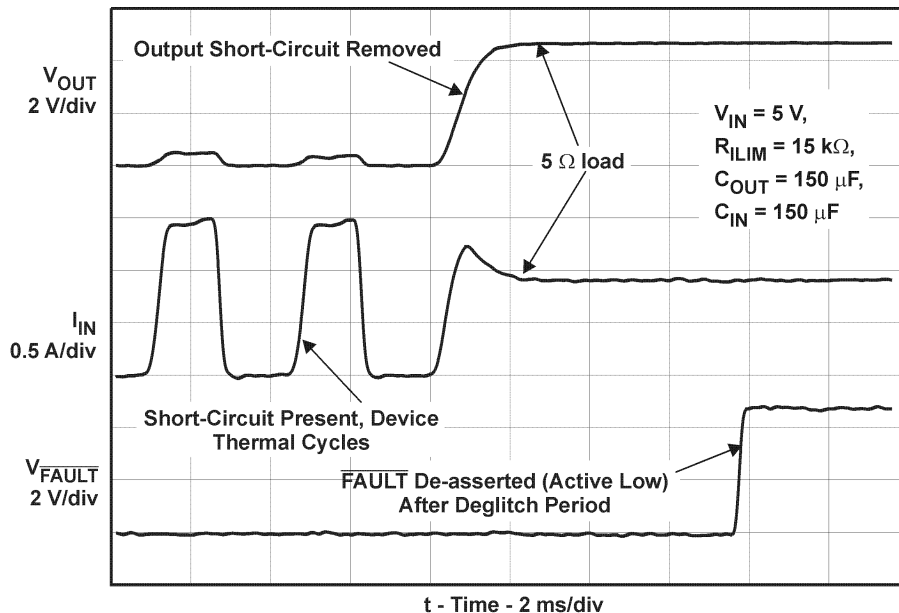

Figure 9. Short-Circuit to Full-Load Recovery Response

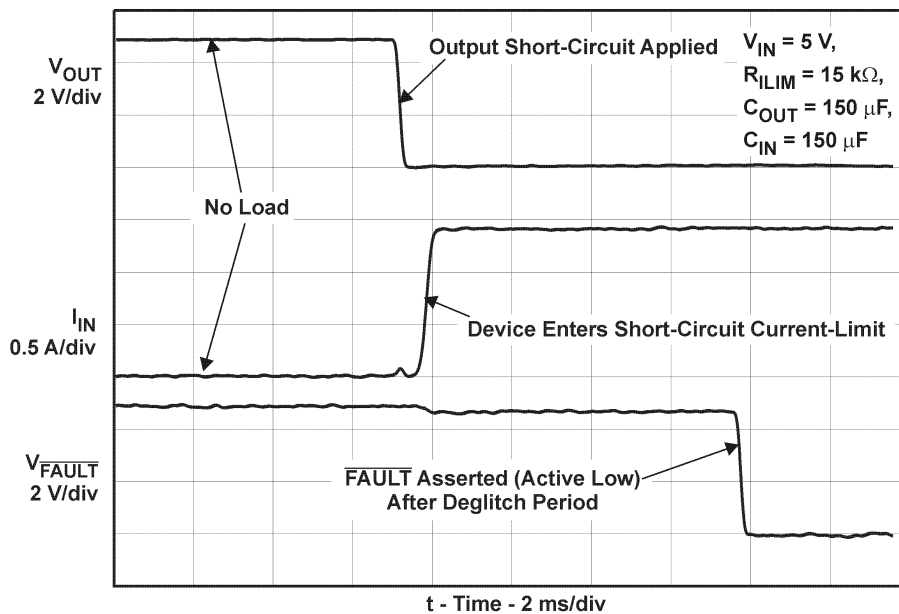

Figure 10. No-Load to Short-Circuit Transient Response

TYPICAL CHARACTERISTICS (continued)

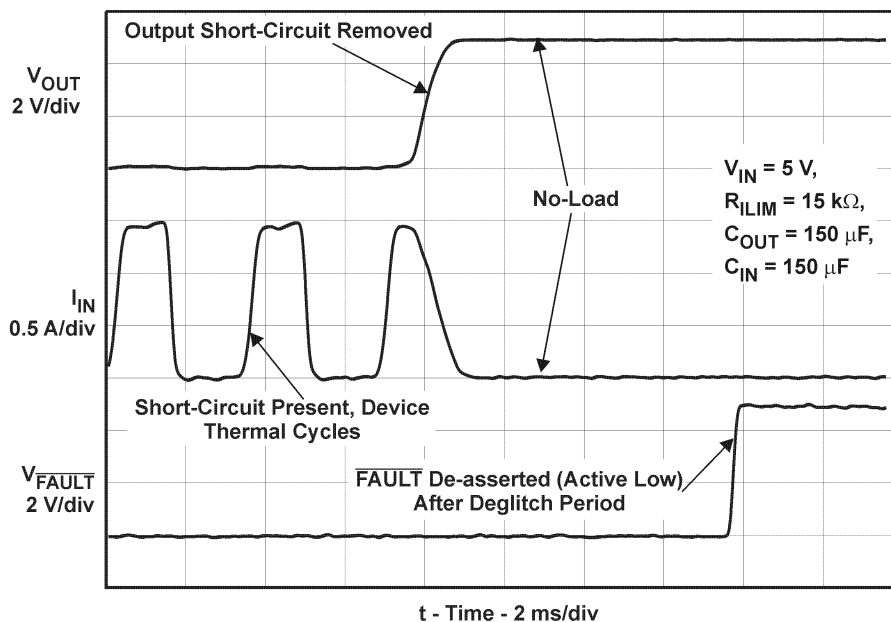

Figure 11. Short-Circuit to No-Load Recovery Response

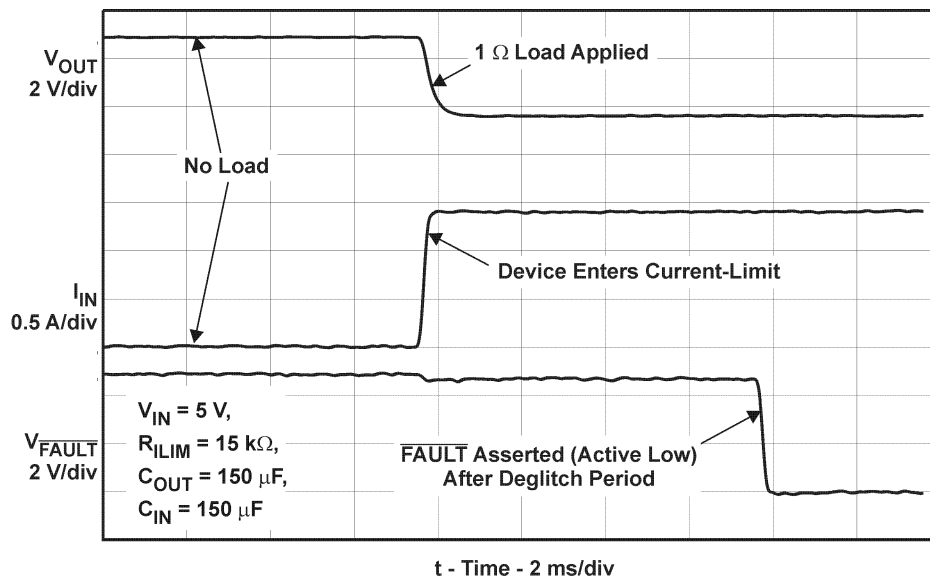

Figure 12. No Load to 1Ω Transient Response

TYPICAL CHARACTERISTICS (continued)

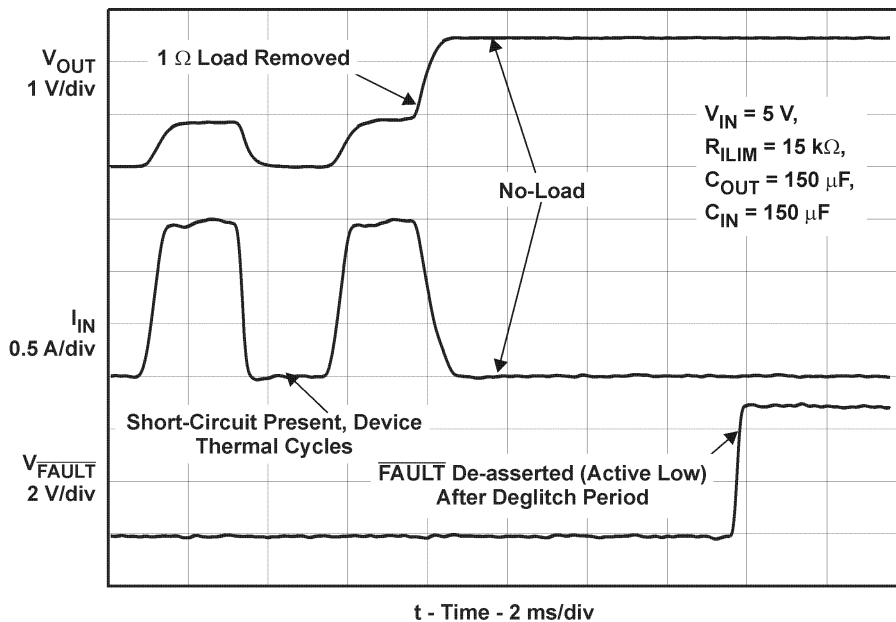

Figure 13. 1Ω to No Load Transient Response

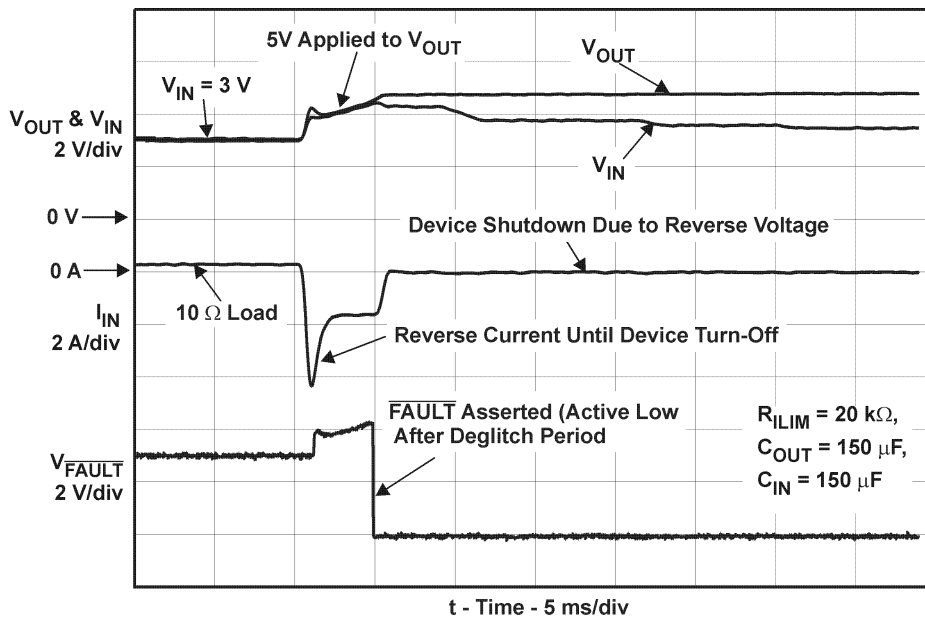

Figure 14. Reverse-Voltage Protection Response

TYPICAL CHARACTERISTICS (continued)

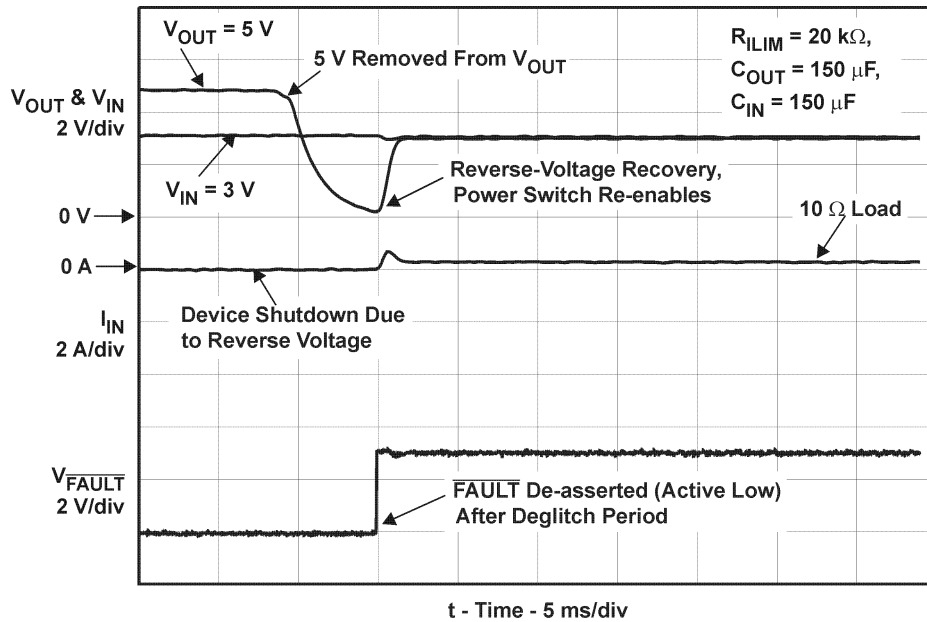

Figure 15. Reverse-Voltage Protection Recovery

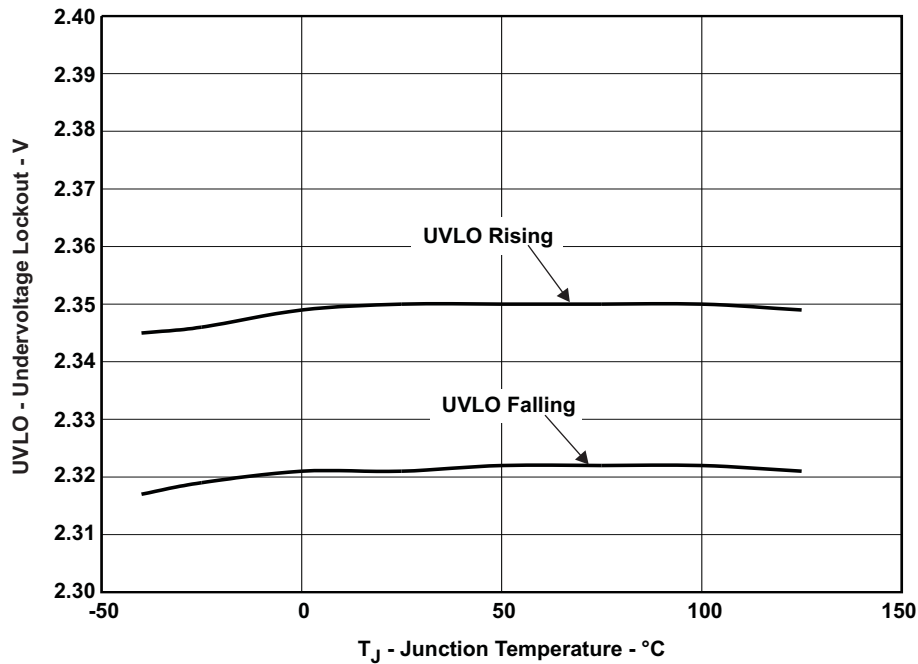

Figure 16. UVLO – Undervoltage Lockout – V

TYPICAL CHARACTERISTICS (continued)

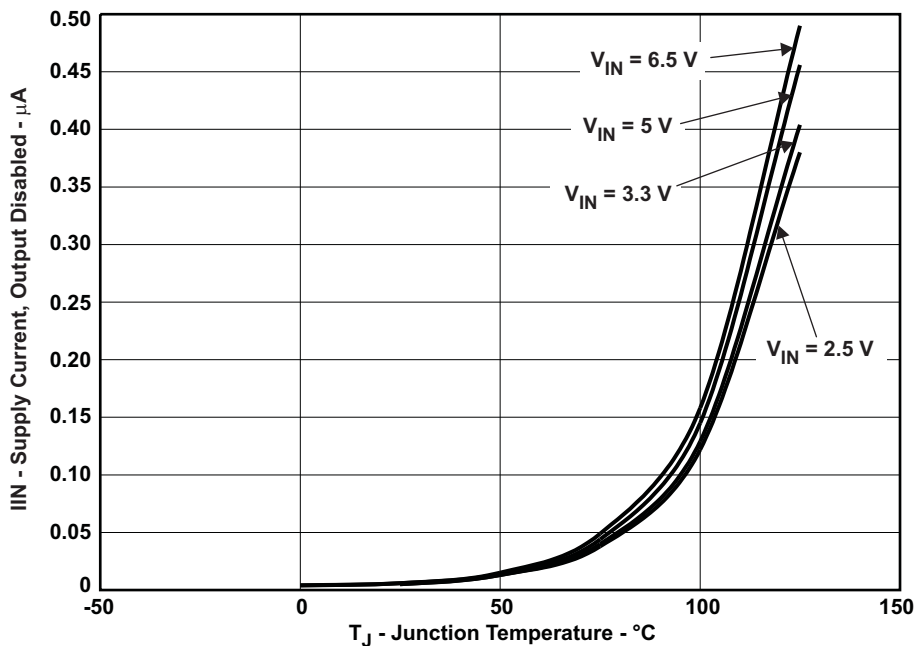

Figure 17. I_{IN} – Supply Current, Output Disabled – μA

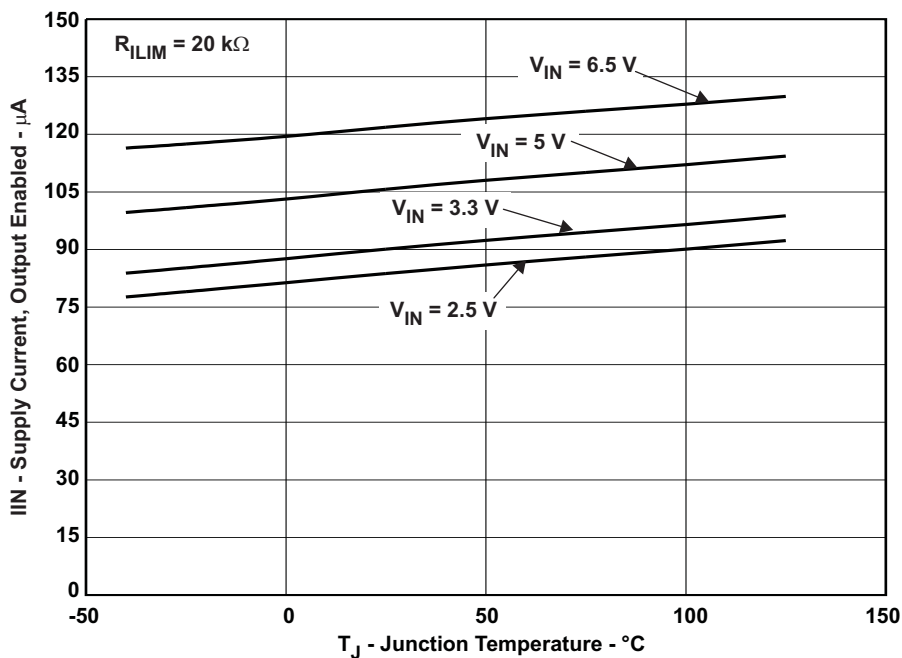

Figure 18. I_{IN} – Supply Current, Output Enabled – μA

TYPICAL CHARACTERISTICS (continued)

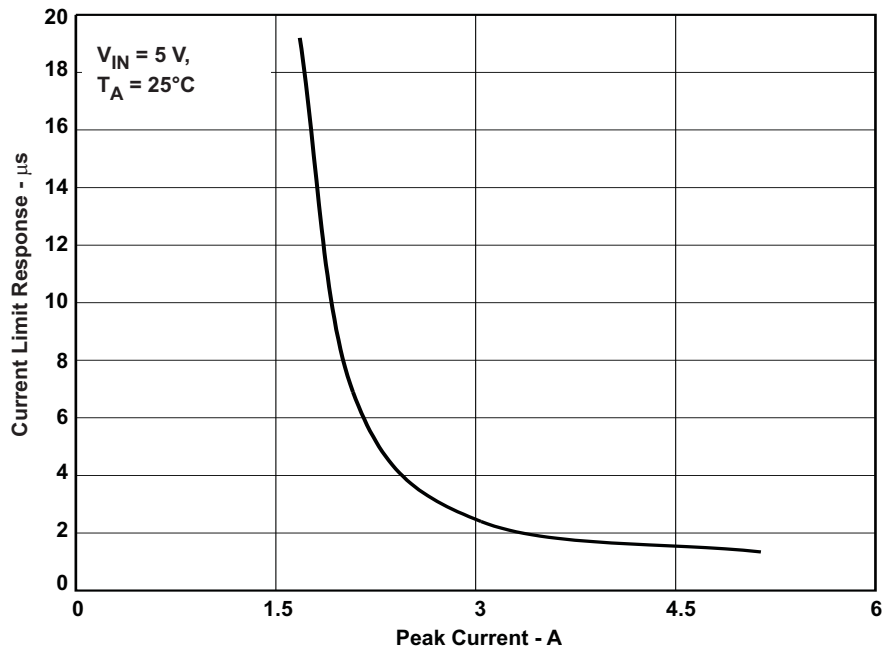

Figure 19. Current Limit Response – μs

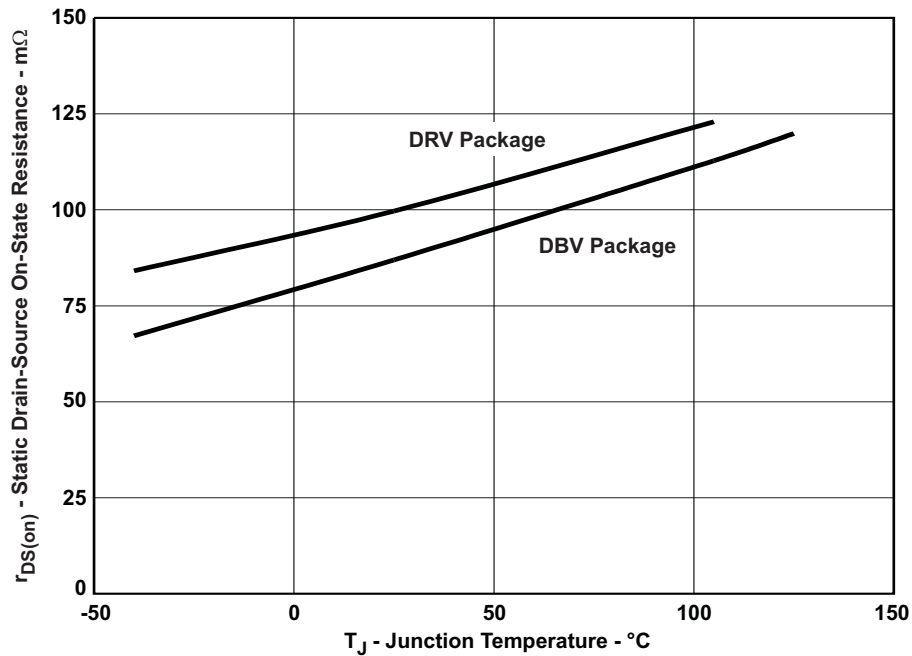

Figure 20. MOSFET r_{DS(on)} Vs. Junction Temperature

DETAILED DESCRIPTION

OVERVIEW

The TPS2550/51 are current-limited, power distribution switches using N-channel MOSFETs for applications where short-circuits or heavy capacitive loads will be encountered. These devices allow the user to program the current-limit threshold between 100 mA and 1.1 A via an external resistor. Additional device shutdown features include overtemperature protection and reverse-voltage protection. The device incorporates an internal charge pump and gate drive circuitry necessary to drive the N-channel MOSFET. The charge pump supplies power to the driver circuit and provides the necessary voltage to pull the gate of the MOSFET above the source. The charge pump operates from input voltages as low as 2.5 V and requires little supply current. The driver controls the gate voltage of the power switch. The driver incorporates circuitry that controls the rise and fall times of the output voltage to limit large current and voltage surges and provide built-in soft-start functionality.

OVERCURRENT

The TPS2550/51 responds to an overcurrent condition by limiting its output current to the I_{OC} and I_{OS} levels shown in [Figure 21](#). Three response profiles are possible depending on the loading conditions and are summarized in [Figure 4](#).

One response profile occurs if the TPS2550/51 is enabled into a short-circuit. The output voltage is held near zero potential with respect to ground and the TPS2550/51 ramps the output current to I_{OS} (see [Figure 7](#)).

A second response profile occurs if a short is applied to the output after the TPS2550/51 is enabled. The device responds to the overcurrent condition within time t_{IOS} (see [Figure 3](#)). The current-sense amplifier is over-driven during this time and momentarily disables the internal current-limit MOSFET. The current-sense amplifier gradually recovers and limits the output current to I_{OS} .

A third response profile occurs if the load current gradually increases. The device first limits the load current to I_{OC} . If the load demands a current greater than I_{OC} , the TPS2550/51 folds back the current to I_{OS} and the output voltage decreases to $I_{OS} \times R_{LOAD}$ for a resistive load, which is shown in [Figure 4](#).

The TPS2550/51 thermal cycles if an overload condition is present long enough to activate thermal limiting in any of the above cases. The device turns off when the junction temperature exceeds 135°C (typ). The device remains off until the junction temperature cools 15°C (typ) and then restarts. The TPS2550/51 cycles on/off until the overload is removed (see [Figure 9](#) and [Figure 11](#)).

REVERSE-VOLTAGE PROTECTION

The reverse-voltage protection feature turns off the N-channel MOSFET whenever the output voltage exceeds the input voltage by 135 mV (typical) for 4-ms. This prevents damage to devices on the input side of the TPS2550/51 by preventing significant current from sinking into the input capacitance. The N-channel MOSFET is allowed to turn-on once the output voltage goes below the input voltage for the same 4-ms deglitch time. The reverse-voltage comparator also asserts the \overline{FAULT} output (active-low) after 4-ms.

FAULT RESPONSE

The \overline{FAULT} open-drain output is asserted (active low) during an overcurrent, overtemperature or reverse-voltage condition. The \overline{output} remains asserted until the fault condition is removed. The TPS2550/51 is designed to eliminate false \overline{FAULT} reporting by using an internal delay "deglitch" circuit for overcurrent (7.5-ms) and reverse-voltage (4-ms) conditions without the need for external circuitry. This ensures that \overline{FAULT} is not accidentally asserted due to normal operation such as starting into a heavy capacitive load. The deglitch circuitry delays entering and leaving fault conditions. Overtemperature conditions are not deglitched and assert the \overline{FAULT} signal immediately.

UNDERVOLTAGE LOCKOUT (UVLO)

The undervoltage lockout (UVLO) circuit disables the power switch until the input voltage reaches the UVLO turn-on threshold. Built-in hysteresis prevents unwanted on/off cycling due to input voltage drop from large current surges.

ENABLE ($\overline{\text{EN}}$ OR EN)

The logic enable controls the power switch, bias for the charge pump, driver, and other circuits to reduce the supply current. The supply current is reduced to less than 1- μA when a logic high is present on $\overline{\text{EN}}$ or when a logic low is present on EN. A logic low input on $\overline{\text{EN}}$ or a logic high input on EN enables the driver, control circuits, and power switch. The enable input is compatible with both TTL and CMOS logic levels.

THERMAL SENSE

The TPS2550/51 protects itself with two independent thermal sensing circuits that monitor the operating temperature of the power-switch and disables operation if the temperature exceeds recommended operating conditions. The device operates in constant-current mode during an overcurrent conditions, which increases the voltage drop across power-switch. The power dissipation in the package is proportional to the voltage drop across the power-switch, so the junction temperature rises during an overcurrent condition. The first thermal sensor turns off the power-switch when the die temperature exceeds 135°C and the part is in current limit. The second thermal sensor turns off the power-switch when the die temperature exceeds 155°C regardless of whether the power-switch is in current limit. Hysteresis is built into both thermal sensors, and the switch turns on after the device has cooled approximately 15°C. The switch continues to cycle off and on until the fault is removed. The open-drain false reporting output $\overline{\text{FAULT}}$ is asserted (active low) immediately during an overtemperature shutdown condition.

APPLICATION INFORMATION

INPUT AND OUTPUT CAPACITANCE

Input and output capacitance improve the performance of the device; the actual capacitance should be optimized for the particular application. For all applications, a 0.01 μF to 0.1 μF ceramic bypass capacitor between IN and GND is recommended as close to the device as possible for local noise de-coupling. This precaution reduces ringing on the input due to power-supply transients. Additional input capacitance may be needed on the input to reduce voltage overshoot from exceeding the absolute maximum voltage of the device during heavy transients. This is especially important during bench testing when long, inductive cables are used to connect the evaluation board to the bench power-supply.

Placing a high-value electrolytic capacitor on the output pin is recommended when the large transient currents are expected on the output. Additionally, bypassing the output with a 0.01 μF to 0.1 μF ceramic capacitor improves the immunity of the device to short-circuit transients.

PROGRAMMING THE CURRENT-LIMIT THRESHOLD

The overcurrent threshold is user programmable via an external resistor. Many applications require that the minimum current-limit is above a certain current level or that the maximum current-limit is below a certain current level, so it is important to consider the tolerance of the overcurrent threshold when selecting a value for R_{ILIM} . The following equations and [Figure 21](#) can be used to calculate the resulting overcurrent threshold for a given external resistor value (I_{ILIM}). [Figure 21](#) includes current-limit tolerance due to variations caused by temperature and process. The traces routing the R_{ILIM} resistor to the TPS2550/51 should be as short as possible to reduce parasitic effects on the current-limit accuracy.

There are two important current-limit thresholds for the device and are related by [Figure 4](#). The first threshold is the short-circuit current threshold I_{OS} . I_{OS} is the current delivered to the load if the part is enabled into a short-circuit or a short-circuit is applied during normal operation. The second threshold is the overcurrent threshold I_{OC} . I_{OC} is the peak DC current that can be delivered to the load before the device begins to limit current. I_{OC} is important if ramped loads or slow transients are common to the application. It is important to consider both I_{OS} and I_{OC} when choosing R_{ILIM} . R_{ILIM} can be selected to provide a current-limit threshold that occurs 1) above a minimum load current or 2) below a maximum load current.

To design above a minimum current-limit threshold, find the intersection of R_{ILIM} and the maximum desired load current on the $I_{OS(min)}$ curve and choose a value of R_{ILIM} below this value. Programming the current-limit above a minimum threshold is important to ensure start-up into full-load or heavy capacitive loads. The resulting maximum DC load current is the intersection of the selected value of R_{ILIM} and the $I_{OC(max)}$ curve.

To design below a maximum DC current level, find the intersection of R_{ILIM} and the maximum desired load current on the $I_{OC(max)}$ curve and choose a value of R_{ILIM} above this value. Programming the current-limit below a maximum threshold is important to avoid current-limiting upstream power supplies causing the input voltage bus to droop. The resulting minimum short-circuit current is the intersection of the selected value of R_{ILIM} and the $I_{OS(min)}$ curve.

Overcurrent Threshold Equations (I_{OC}):

- $I_{OC(max)}$ (mA) = (24500 V) / I_{ILIM} (k Ω)^{0.975}
- $I_{OC(typ)}$ (mA) = (23800 V) / I_{ILIM} (k Ω)^{0.985}
- $I_{OC(min)}$ (mA) = (23100 V) / I_{ILIM} (k Ω)^{0.996}

Short-Circuit Current Equations (I_{OS}):

- $I_{OS(max)}$ (mA) = (25500 V) / I_{ILIM} (k Ω)^{1.013}
- $I_{OS(typ)}$ (mA) = (28700 V) / I_{ILIM} (k Ω)^{1.114}
- $I_{OS(min)}$ (mA) = (39700 V) / I_{ILIM} (k Ω)^{1.342}

where $14.3 \text{ k}\Omega \leq R_{ILIM} \leq 80.6 \text{ k}\Omega$. $I_{OS(typ)}$ and $I_{OS(max)}$ are not plotted to improve graph clarity.

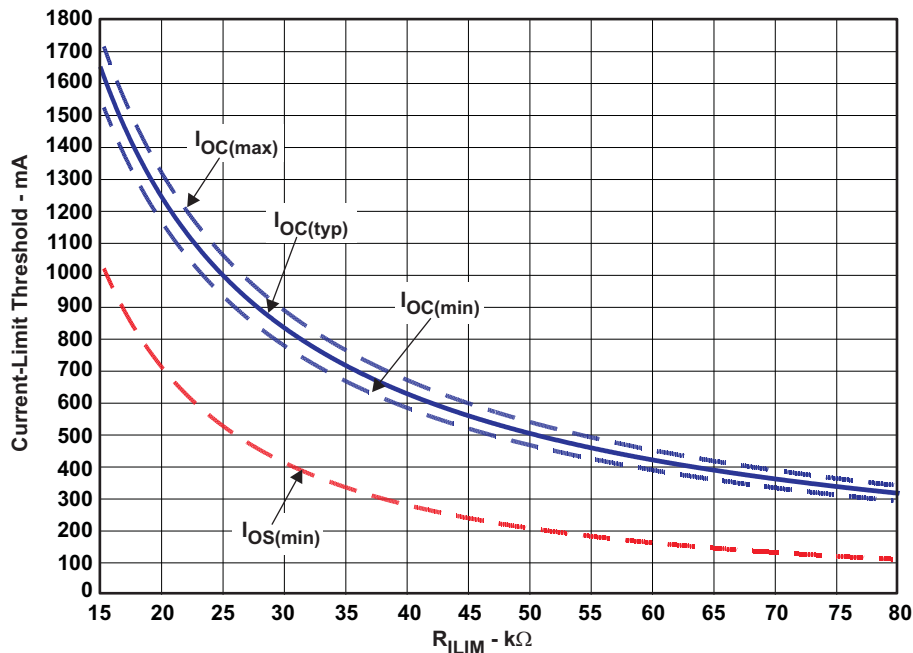

Figure 21. Current-Limit Threshold Vs. R_ILIM

APPLICATION 1: DESIGNING ABOVE A MINIMUM CURRENT-LIMIT

Some applications require that current-limiting cannot occur below a certain threshold. For this example, assume that 1 A must be delivered to the load so that the minimum desired current-limit threshold is 1000 mA. Use the I_{OS} equations and Figure 21 to select R_{ILIM} .

- $I_{OS(min)}$ (mA) = 1000 mA
- $I_{OS(min)}$ (mA) = (39700 V) / I_{ILIM} (kΩ)^{1.342}
- R_{ILIM} (kΩ) = [(39700 V) / ($I_{OS(min)}$ (mA))]^{1/1.342}
- R_{ILIM} = 15.54 kΩ

Select the closest 1% resistor less than the calculated value: R_{ILIM} = 15.4 kΩ. This sets the minimum current-limit threshold at 1 A. Use the I_{OC} equations, Figure 21, and the previously calculated value for R_{ILIM} to calculate the maximum resulting current-limit threshold.

- R_{ILIM} = 15.4 kΩ
- $I_{OC(max)}$ (mA) = (24500 V) / I_{ILIM} (kΩ)^{0.975}
- $I_{OC(max)}$ (mA) = (24500 V) / (15 (kΩ))^{0.975}
- $I_{OC(max)}$ = 1703 mA

The resulting maximum current-limit threshold is 1.7 A with a 15.4 kΩ resistor.

APPLICATION 2: DESIGNING BELOW A MAXIMUM CURRENT-LIMIT

Some applications require that current-limiting must occur below a certain threshold. For this example, assume that the desired upper current-limit threshold must be below 1.25 A to protect an up-stream power supply. Use the I_{OC} equations and Figure 21 to select R_{ILIM} .

- $I_{OC(max)}$ (mA) = 1250 mA
- $I_{OC(max)}$ (mA) = (24500 V) / I_{ILIM} (kΩ)^{0.975}
- R_{ILIM} (kΩ) = [(24500 V) / ($I_{OC(max)}$ (mA))]^{1/0.975}
- R_{ILIM} = 21.15 kΩ

Select the closest 1% resistor greater than the calculated value: $R_{ILIM} = 21.5 \text{ k}\Omega$. This sets the maximum current-limit threshold at 1.25 A. Use the I_{OS} equations, [Figure 21](#), and the previously calculated value for R_{ILIM} to calculate the minimum resulting current-limit threshold.

- $R_{ILIM} = 21.5 \text{ k}\Omega$
- $I_{OS(min)} \text{ (mA)} = (39700 \text{ V}) / I_{ILIM} \text{ (k}\Omega)^{1.342}$
- $I_{OS(min)} \text{ (mA)} = (39700 \text{ V}) / (21.5 \text{ (k}\Omega))^{1.342}$
- $I_{OS(min)} = 647 \text{ mA}$

The resulting minimum current-limit threshold is 647 mA with a 21.5 kΩ resistor.

POWER DISSIPATION AND JUNCTION TEMPERATURE

The low on-resistance of the N-channel MOSFET allows small surface-mount packages to pass large currents. It is good design practice to estimate power dissipation and junction temperature. The below analysis gives an approximation for calculating junction temperature based on the power dissipation in the package. However, it is important to note that thermal analysis is strongly dependent on additional system level factors. Such factors include air flow, board layout, copper thickness and surface area, and proximity to other devices dissipating power. Good thermal design practice must include all system level factors in addition to individual component analysis.

Begin by determining the $r_{DS(on)}$ of the N-channel MOSFET relative to the input voltage and operating temperature. As an initial estimate, use the highest operating ambient temperature of interest and read $r_{DS(on)}$ from the typical characteristics graph. Using this value, the power dissipation can be calculated by:

$$P_D = r_{DS(on)} \times I_{OUT}^2$$

Where:

P_D = Total power dissipation (W)

$r_{DS(on)}$ = Power switch on-resistance (Ω)

I_{OUT} = Maximum current-limit threshold (A)

This step calculates the total power dissipation of the N-channel MOSFET.

Finally, calculate the junction temperature:

$$T_J = P_D \times R_{\theta JA} + T_A$$

Where:

T_A = Ambient temperature (°C)

$R_{\theta JA}$ = Thermal resistance (°C/W)

P_D = Total power dissipation (W)

Compare the calculated junction temperature with the initial estimate. If they are not within a few degrees, repeat the calculation using the "refined" $r_{DS(on)}$ from the previous calculation as the new estimate. Two or three iterations are generally sufficient to achieve the desired result. The final junction temperature is highly dependent on thermal resistance $R_{\theta JA}$, and thermal resistance is highly dependent on the individual package and board layout. The "Dissipating Rating Table" at the beginning of this document provides example thermal resistance for specific packages and board layouts.

UNIVERSAL SERIAL BUS (USB) POWER-DISTRIBUTION REQUIREMENTS

One application for this device is for current-limiting in universal serial bus (USB) applications. The original USB interface was a 12-Mb/s or 1.5-Mb/s, multiplexed serial bus designed for low-to-medium bandwidth PC peripherals (e.g., keyboards, printers, scanners, and mice). As the demand for more bandwidth increased, the USB 2.0 standard was introduced increasing the maximum data rate to 480-Mb/s. The four-wire USB interface is conceived for dynamic attach-detach (hot plug-unplug) of peripherals. Two lines are provided for differential data, and two lines are provided for 5-V power distribution.

USB data is a 3.3-V level signal, but power is distributed at 5 V to allow for voltage drops in cases where power is distributed through more than one hub across long cables. Each function must provide its own regulated 3.3 V from the 5-V input or its own internal power supply. The USB specification classifies two different classes of

devices depending on its maximum current draw. A device classified as low-power can draw up to 100 mA as defined by the standard. A device classified as high-power can draw up to 500 mA. It is important that the minimum current-limit threshold of the current-limiting power-switch exceed the maximum current-limit draw of the intended application. The latest USB standard should always be referenced when considering the current-limit threshold

The USB specification defines two types of devices as hubs and functions. A USB hub is a device that contains multiple ports for different USB devices to connect and can be self-powered (SPH) or bus-powered (BPH). A function is a USB device that is able to transmit or receive data or control information over the bus. A USB function can be embedded in a USB hub. A USB function can be one of three types included in the list below.

- Low-power, bus-powered function
- High-power, bus-powered function
- Self-powered function

SPHs and BPHs distribute data and power to downstream functions. The TPS2550/51 has higher current capability than required for a single USB port allowing it to power multiple downstream ports.

SELF-POWERED AND BUS-POWERED HUBS

A SPH has a local power supply that powers embedded functions and downstream ports. This power supply must provide between 4.75 V to 5.25 V to downstream facing devices under full-load and no-load conditions. SPHs are required to have current-limit protection and must report overcurrent conditions to the USB controller. Typical SPHs are desktop PCs, monitors, printers, and stand-alone hubs.

A BPH obtains all power from an upstream port and often contains an embedded function. It must power up with less than 100 mA. The BPH usually has one embedded function, and power is always available to the controller of the hub. If the embedded function and hub require more than 100 mA on power up, the power to the embedded function may need to be kept off until enumeration is completed. This is accomplished by removing power or by shutting off the clock to the embedded function. Power switching the embedded function is not necessary if the aggregate power draw for the function and controller is less than 100 mA. The total current drawn by the bus-powered device is the sum of the current to the controller, the embedded function, and the downstream ports, and it is limited to 500 mA from an upstream port.

LOW-POWER BUS-POWERED AND HIGH-POWER BUS-POWERED FUNCTIONS

Both low-power and high-power bus-powered functions obtain all power from upstream ports. Low-power functions always draw less than 100 mA; high-power functions must draw less than 100 mA at power up and can draw up to 500 mA after enumeration. If the load of the function is more than the parallel combination of 44 Ω and 10 μ F at power up, the device must implement inrush current limiting.

USB POWER-DISTRIBUTION REQUIREMENTS

USB can be implemented in several ways regardless of the type of USB device being developed. Several power-distribution features must be implemented.

- SPHs must:
 - Current-limit downstream ports
 - Report overcurrent conditions
- BPHs must:
 - Enable/disable power to downstream ports
 - Power up at <100 mA
 - Limit inrush current (<44 Ω and 10 μ F)
- Functions must:
 - Limit inrush currents
 - Power up at <100 mA

The feature set of the TPS2550/51 meets each of these requirements. The integrated current-limiting and overcurrent reporting is required by self-powered hubs. The logic-level enable and controlled rise times meet the need of both input and output ports on bus-powered hubs and the input ports for bus-powered functions.

AUTO-RETRY FUNCTIONALITY

Some applications require that an overcurrent condition disables the part momentarily during a fault condition and re-enables after a pre-set time. This *auto-retry* functionality can be implemented with an external resistor and capacitor. During a fault condition, $\overline{\text{FAULT}}$ pulls low disabling the part. The part is disabled when EN is pulled low, and $\overline{\text{FAULT}}$ goes high impedance allowing C_{RETRY} to begin charging. The part re-enables when the voltage on EN reaches the turnon threshold, and the auto-retry time is determined by the resistor/capacitor time constant. The part will continue to cycle in this manner until the fault condition is removed.

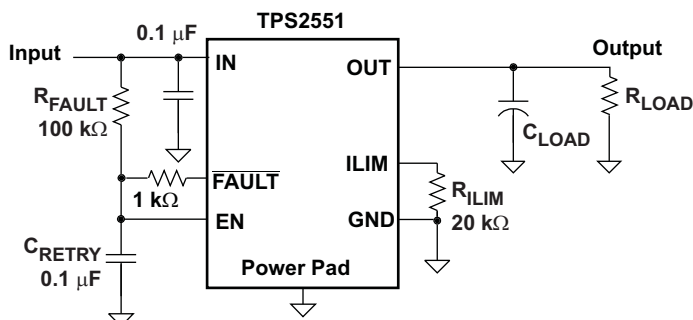

Figure 22. Auto-Retry Functionality

Some applications require auto-retry functionality and the ability to enable/disable with an external logic signal. The figure below shows how an external logic signal can drive EN through R_{FAULT} and maintain auto-retry functionality. The resistor/capacitor time constant determines the auto-retry time-out period.

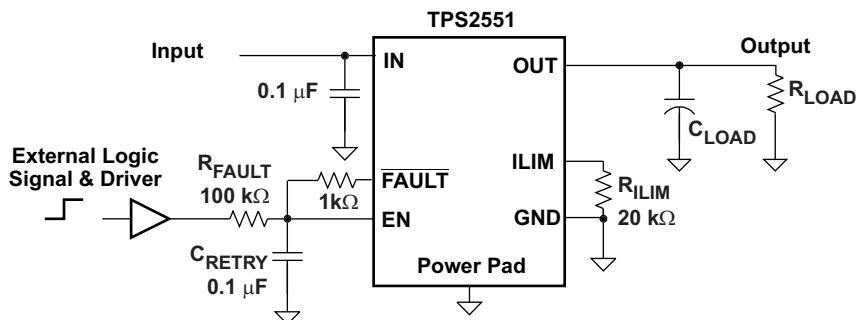

Figure 23. Auto-Retry Functionality With External EN Signal

LATCH-OFF FUNCTIONALITY

The circuit in Figure 24 uses an SN74HC00 quad-NAND gate to implement overcurrent latch-off. The SN74HC00 high-speed CMOS logic gate is selected because it operates over the 2.5V – 6.5V range of the TPS2550/51.

This circuit is designed to work with the active-high TPS2551. ENABLE must be logic low during start-up until V_{IN} is stable to ensure that the switch initializes in the OFF state. A logic high on ENABLE turns on the switch after V_{IN} is stable. $\overline{\text{FAULT}}$ momentarily pulls low during an overcurrent condition, which latches $\overline{\text{STAT}}$ logic low and disables the switch. The host can monitor $\overline{\text{STAT}}$ for an overcurrent condition. Toggling ENABLE resets $\overline{\text{STAT}}$ and re-enables the switch.

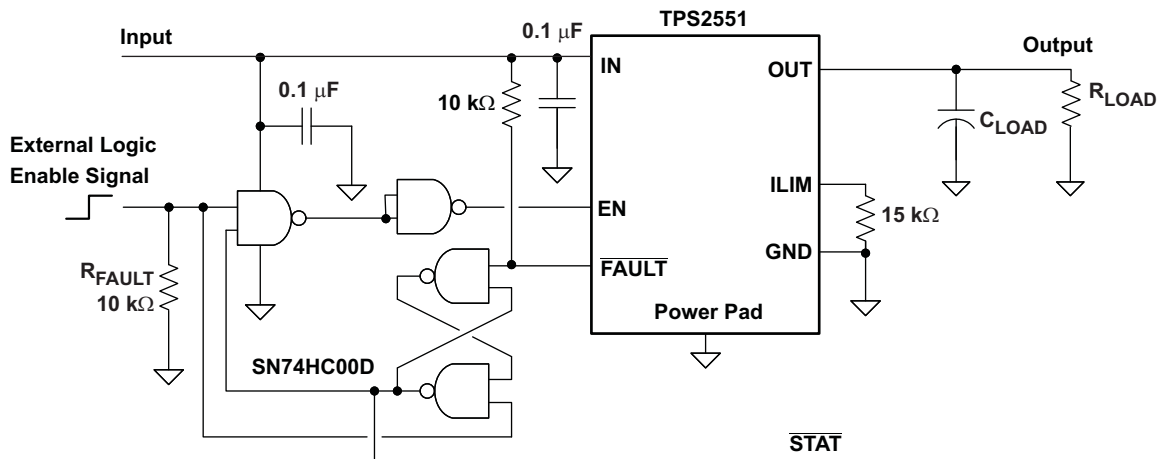

Figure 24. Overcurrent Latch-Off Using a Quad-NAND Gate

TWO-LEVEL CURRENT-LIMIT CIRCUIT

Some applications require different current-limit thresholds depending on external system conditions. Figure 25 shows an implementation for an externally controlled, two-level current-limit circuit. The current-limit threshold is set by the total resistance from ILIM to GND (see previously discussed "Programming the Current-Limit Threshold" section). A logic-level input enables/disables MOSFET Q1 and changes the current-limit threshold by modifying the total resistance from ILIM to GND. Additional MOSFETs/resistor combinations can be used in parallel to Q1/R2 to increase the number of additional current-limit levels.

NOTE:

ILIM should never be driven directly with an external signal.

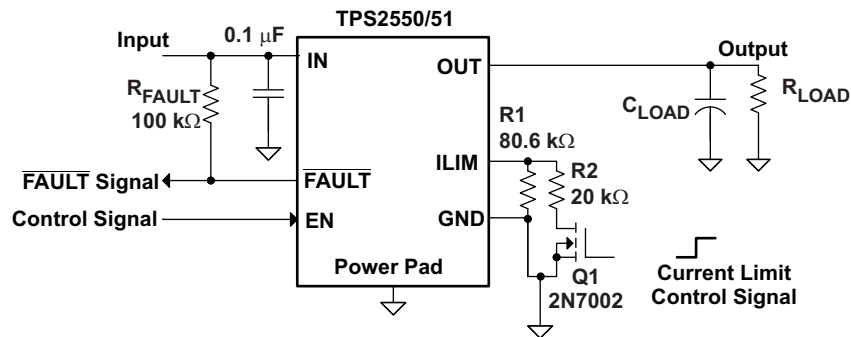

Figure 25. Two-Level Current-Limit Circuit

PACKAGING INFORMATION

Orderable Device	Status (1)	Package Type	Package Drawing	Pins	Package Qty	Eco Plan (2)	Lead/Ball Finish (6)	MSL Peak Temp (3)	Op Temp (°C)	Device Marking (4/5)	Samples
TPS2550DBVR	NRND	SOT-23	DBV	6	3000	Green (RoHS & no Sb/Br)	CU NIPDAU	Level-1-260C-UNLIM	-40 to 85	2550	
TPS2550DBVT	NRND	SOT-23	DBV	6	250	Green (RoHS & no Sb/Br)	CU NIPDAU	Level-1-260C-UNLIM	-40 to 85	2550	
TPS2550DBVTG4	NRND	SOT-23	DBV	6	250	Green (RoHS & no Sb/Br)	CU NIPDAU	Level-1-260C-UNLIM	-40 to 85	2550	
TPS2550DRVR	NRND	WSON	DRV	6	3000	Green (RoHS & no Sb/Br)	CU NIPDAU	Level-1-260C-UNLIM	-40 to 85	CKJ	
TPS2550DRVRG4	NRND	WSON	DRV	6	3000	Green (RoHS & no Sb/Br)	CU NIPDAU	Level-1-260C-UNLIM	-40 to 85	CKJ	
TPS2550DRVT	NRND	WSON	DRV	6	250	Green (RoHS & no Sb/Br)	CU NIPDAU	Level-1-260C-UNLIM	-40 to 85	CKJ	
TPS2551DBVR	NRND	SOT-23	DBV	6	3000	Green (RoHS & no Sb/Br)	CU NIPDAU CU SN	Level-1-260C-UNLIM	-40 to 85	2551	
TPS2551DBVT	NRND	SOT-23	DBV	6	250	Green (RoHS & no Sb/Br)	CU NIPDAU CU SN	Level-1-260C-UNLIM	-40 to 85	2551	
TPS2551DRVR	NRND	WSON	DRV	6	3000	Green (RoHS & no Sb/Br)	CU NIPDAU	Level-1-260C-UNLIM	-40 to 85	CKK	
TPS2551DRVT	NRND	WSON	DRV	6	250	Green (RoHS & no Sb/Br)	CU NIPDAU	Level-1-260C-UNLIM	-40 to 85	CKK	

(1) The marketing status values are defined as follows:

ACTIVE: Product device recommended for new designs.

LIFEBUY: TI has announced that the device will be discontinued, and a lifetime-buy period is in effect.

NRND: Not recommended for new designs. Device is in production to support existing customers, but TI does not recommend using this part in a new design.

PREVIEW: Device has been announced but is not in production. Samples may or may not be available.

OBSOLETE: TI has discontinued the production of the device.

(2) **RoHS:** TI defines "RoHS" to mean semiconductor products that are compliant with the current EU RoHS requirements for all 10 RoHS substances, including the requirement that RoHS substance do not exceed 0.1% by weight in homogeneous materials. Where designed to be soldered at high temperatures, "RoHS" products are suitable for use in specified lead-free processes. TI may reference these types of products as "Pb-Free".

RoHS Exempt: TI defines "RoHS Exempt" to mean products that contain lead but are compliant with EU RoHS pursuant to a specific EU RoHS exemption.

Green: TI defines "Green" to mean the content of Chlorine (Cl) and Bromine (Br) based flame retardants meet JS709B low halogen requirements of <=1000ppm threshold. Antimony trioxide based flame retardants must also meet the <=1000ppm threshold requirement.

(3) MSL, Peak Temp. - The Moisture Sensitivity Level rating according to the JEDEC industry standard classifications, and peak solder temperature.

(4) There may be additional marking, which relates to the logo, the lot trace code information, or the environmental category on the device.

(5) Multiple Device Markings will be inside parentheses. Only one Device Marking contained in parentheses and separated by a "~" will appear on a device. If a line is indented then it is a continuation of the previous line and the two combined represent the entire Device Marking for that device.

(6) Lead/Ball Finish - Orderable Devices may have multiple material finish options. Finish options are separated by a vertical ruled line. Lead/Ball Finish values may wrap to two lines if the finish value exceeds the maximum column width.

Important Information and Disclaimer:The information provided on this page represents TI's knowledge and belief as of the date that it is provided. TI bases its knowledge and belief on information provided by third parties, and makes no representation or warranty as to the accuracy of such information. Efforts are underway to better integrate information from third parties. TI has taken and continues to take reasonable steps to provide representative and accurate information but may not have conducted destructive testing or chemical analysis on incoming materials and chemicals. TI and TI suppliers consider certain information to be proprietary, and thus CAS numbers and other limited information may not be available for release.

In no event shall TI's liability arising out of such information exceed the total purchase price of the TI part(s) at issue in this document sold by TI to Customer on an annual basis.

OTHER QUALIFIED VERSIONS OF TPS2551 :

- Automotive: [TPS2551-Q1](#)

NOTE: Qualified Version Definitions:

- Automotive - Q100 devices qualified for high-reliability automotive applications targeting zero defects

TAPE AND REEL INFORMATION



QUADRANT ASSIGNMENTS FOR PIN 1 ORIENTATION IN TAPE



*All dimensions are nominal

Device	Package Type	Package Drawing	Pins	SPQ	Reel Diameter (mm)	Reel Width W1 (mm)	A0 (mm)	B0 (mm)	K0 (mm)	P1 (mm)	W (mm)	Pin1 Quadrant
TPS2550DBVR	SOT-23	DBV	6	3000	180.0	8.4	3.2	3.2	1.4	4.0	8.0	Q3
TPS2550DBVT	SOT-23	DBV	6	250	180.0	8.4	3.2	3.2	1.4	4.0	8.0	Q3
TPS2550DRVR	WSO	DRV	6	3000	179.0	8.4	2.2	2.2	1.2	4.0	8.0	Q2
TPS2550DRVT	WSO	DRV	6	250	179.0	8.4	2.2	2.2	1.2	4.0	8.0	Q2
TPS2551DBVR	SOT-23	DBV	6	3000	179.0	8.4	3.2	3.2	1.4	4.0	8.0	Q3
TPS2551DBVT	SOT-23	DBV	6	3000	178.0	9.0	3.23	3.17	1.37	4.0	8.0	Q3
TPS2551DBVT	SOT-23	DBV	6	250	178.0	9.0	3.23	3.17	1.37	4.0	8.0	Q3
TPS2551DBVT	SOT-23	DBV	6	250	179.0	8.4	3.2	3.2	1.4	4.0	8.0	Q3
TPS2551DRVR	WSO	DRV	6	3000	179.0	8.4	2.2	2.2	1.2	4.0	8.0	Q2
TPS2551DRVT	WSO	DRV	6	250	179.0	8.4	2.2	2.2	1.2	4.0	8.0	Q2

TAPE AND REEL BOX DIMENSIONS

*All dimensions are nominal

Device	Package Type	Package Drawing	Pins	SPQ	Length (mm)	Width (mm)	Height (mm)
TPS2550DBVR	SOT-23	DBV	6	3000	203.0	203.0	35.0
TPS2550DBVT	SOT-23	DBV	6	250	203.0	203.0	35.0
TPS2550DRVR	WSON	DRV	6	3000	203.0	203.0	35.0
TPS2550DRVT	WSON	DRV	6	250	203.0	203.0	35.0
TPS2551DBVR	SOT-23	DBV	6	3000	203.0	203.0	35.0
TPS2551DBVR	SOT-23	DBV	6	3000	180.0	180.0	18.0
TPS2551DBVT	SOT-23	DBV	6	250	180.0	180.0	18.0
TPS2551DBVT	SOT-23	DBV	6	250	203.0	203.0	35.0
TPS2551DRVR	WSON	DRV	6	3000	203.0	203.0	35.0
TPS2551DRVT	WSON	DRV	6	250	203.0	203.0	35.0

GENERIC PACKAGE VIEW

DRV 6

WSON - 0.8 mm max height

PLASTIC SMALL OUTLINE - NO LEAD



Images above are just a representation of the package family, actual package may vary.
Refer to the product data sheet for package details.

4206925/F



4222173/B 04/2018

NOTES:

1. All linear dimensions are in millimeters. Any dimensions in parenthesis are for reference only. Dimensioning and tolerancing per ASME Y14.5M.
2. This drawing is subject to change without notice.
3. The package thermal pad must be soldered to the printed circuit board for thermal and mechanical performance.

EXAMPLE STENCIL DESIGN

DRV0006A

WSON - 0.8 mm max height

PLASTIC SMALL OUTLINE - NO LEAD



SOLDER PASTE EXAMPLE
BASED ON 0.125 mm THICK STENCIL

EXPOSED PAD #7
88% PRINTED SOLDER COVERAGE BY AREA UNDER PACKAGE
SCALE:30X

4222173/B 04/2018

NOTES: (continued)

6. Laser cutting apertures with trapezoidal walls and rounded corners may offer better paste release. IPC-7525 may have alternate design recommendations.

DBV0006A



PACKAGE OUTLINE

SOT-23 - 1.45 mm max height

SMALL OUTLINE TRANSISTOR



4214840/B 03/2018

NOTES:

1. All linear dimensions are in millimeters. Any dimensions in parenthesis are for reference only. Dimensioning and tolerancing per ASME Y14.5M.
2. This drawing is subject to change without notice.
3. Body dimensions do not include mold flash or protrusion. Mold flash and protrusion shall not exceed 0.15 per side.
4. Leads 1,2,3 may be wider than leads 4,5,6 for package orientation.
5. Reference JEDEC MO-178.

EXAMPLE BOARD LAYOUT

DBV0006A

SOT-23 - 1.45 mm max height

SMALL OUTLINE TRANSISTOR



LAND PATTERN EXAMPLE
EXPOSED METAL SHOWN
SCALE:15X



SOLDER MASK DETAILS

4214840/B 03/2018

NOTES: (continued)

- 6. Publication IPC-7351 may have alternate designs.
- 7. Solder mask tolerances between and around signal pads can vary based on board fabrication site.

EXAMPLE STENCIL DESIGN

DBV0006A

SOT-23 - 1.45 mm max height

SMALL OUTLINE TRANSISTOR



SOLDER PASTE EXAMPLE
BASED ON 0.125 mm THICK STENCIL
SCALE:15X

4214840/B 03/2018

NOTES: (continued)

8. Laser cutting apertures with trapezoidal walls and rounded corners may offer better paste release. IPC-7525 may have alternate design recommendations.
9. Board assembly site may have different recommendations for stencil design.

IMPORTANT NOTICE AND DISCLAIMER

TI PROVIDES TECHNICAL AND RELIABILITY DATA (INCLUDING DATASHEETS), DESIGN RESOURCES (INCLUDING REFERENCE DESIGNS), APPLICATION OR OTHER DESIGN ADVICE, WEB TOOLS, SAFETY INFORMATION, AND OTHER RESOURCES "AS IS" AND WITH ALL FAULTS, AND DISCLAIMS ALL WARRANTIES, EXPRESS AND IMPLIED, INCLUDING WITHOUT LIMITATION ANY IMPLIED WARRANTIES OF MERCHANTABILITY, FITNESS FOR A PARTICULAR PURPOSE OR NON-INFRINGEMENT OF THIRD PARTY INTELLECTUAL PROPERTY RIGHTS.

These resources are intended for skilled developers designing with TI products. You are solely responsible for (1) selecting the appropriate TI products for your application, (2) designing, validating and testing your application, and (3) ensuring your application meets applicable standards, and any other safety, security, or other requirements. These resources are subject to change without notice. TI grants you permission to use these resources only for development of an application that uses the TI products described in the resource. Other reproduction and display of these resources is prohibited. No license is granted to any other TI intellectual property right or to any third party intellectual property right. TI disclaims responsibility for, and you will fully indemnify TI and its representatives against, any claims, damages, costs, losses, and liabilities arising out of your use of these resources.

TI's products are provided subject to TI's Terms of Sale (www.ti.com/legal/termsofsale.html) or other applicable terms available either on ti.com or provided in conjunction with such TI products. TI's provision of these resources does not expand or otherwise alter TI's applicable warranties or warranty disclaimers for TI products.

Mailing Address: Texas Instruments, Post Office Box 655303, Dallas, Texas 75265
Copyright © 2019, Texas Instruments Incorporated

Looking for pricing, stock, or lifecycle information?

Click below to explore more details on WIN SOURCE:

 [View TPS2551DRV1 on WIN SOURCE](#)

 [Texas Instruments](#) Information

Optimize Your Supply Chain with WIN SOURCE Solutions

-  Global Sourcing Solution
-  Obsolete Management
-  Cost Control Management
-  Shortage Management
-  Alternative Solution
-  Excess Inventory Management