



**THE DATASHEET OF  
TPS3852G33DRBT**



# TPS3852 Precision Voltage Supervisor with Programmable Window Watchdog Timer

## 1 Features

- VDD Input Voltage Range: 1.6 V to 6.5 V
- 0.8% Voltage Threshold Accuracy
- Low Supply Current:  $I_{DD} = 10 \mu\text{A}$  (typical)
- User-Programmable Watchdog Timeout
- Factory Programmed Precision Watchdog and Reset Timers:
  - $\pm 15\%$  Accurate WDT and RST Delays
- Open-Drain Outputs
- Manual Reset Input ( $\overline{\text{MR}}$ )
- Precision Undervoltage Monitoring
  - Supports Common Rails from 1.8 V to 5 V
  - 4% and 7% Thresholds Available
  - 0.5% Hysteresis
- Watchdog Disable Feature
- Available in a Small 3-mm x 3-mm, 8-Pin VSON Package

## 2 Applications

- Safety Critical Applications
- Telematics Control Units
- High-Reliability Industrial Systems
- Patient Monitoring
- Industrial Control Systems
- FPGAs and ASICs
- Microcontrollers and DSPs

## 3 Description

The TPS3852 is a precision voltage supervisor with an integrated window watchdog timer. The TPS3852 includes a precision undervoltage supervisor with an undervoltage threshold ( $V_{ITN}$ ) that achieves 0.8% accuracy over the specified temperature range of  $-40^\circ\text{C}$  to  $+125^\circ\text{C}$ . In addition, the TPS3852 includes accurate hysteresis making the device ideal for use with tight tolerance systems. The supervisor RESET delay features a 15% accuracy, high-precision delay timer.

The TPS3852 includes a programmable window watchdog timer for a wide variety of applications. The dedicated watchdog output ( $\overline{\text{WDO}}$ ) enables increased resolution to help determine the nature of fault conditions. The watchdog timeouts can be programmed either by an external capacitor, or by factory-programmed default delay settings. The watchdog can be disabled to avoid undesired watchdog timeouts during the development process.

The TPS3852 is available in a small 3.00-mm x 3.00-mm, 8-pin VSON package.

### Device Information<sup>(1)</sup>

PART NUMBER	PACKAGE	BODY SIZE (NOM)
TPS3852	VSON (8)	3.00 mm x 3.00 mm

(1) For all available packages, see the orderable addendum at the end of the data sheet.

### Typical Application Circuit

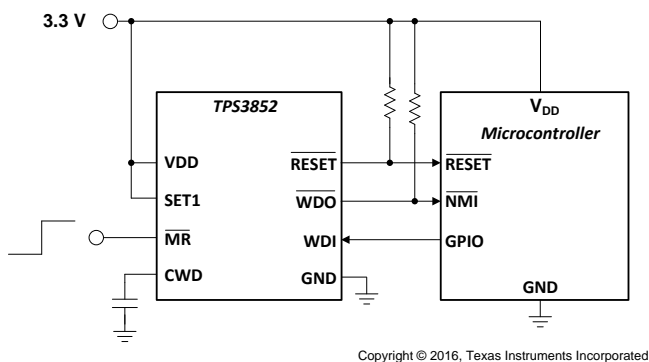

### Undervoltage Threshold ( $V_{ITN}$ ) Accuracy vs Temperature

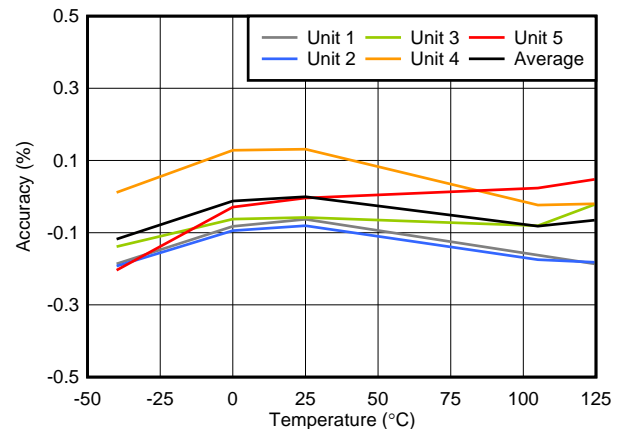

## Table of Contents

<b>1 Features</b> .....	<b>1</b>	7.4 Device Functional Modes.....	<b>15</b>
<b>2 Applications</b> .....	<b>1</b>	<b>8 Application and Implementation</b> .....	<b>16</b>
<b>3 Description</b> .....	<b>1</b>	8.1 Application Information.....	<b>16</b>
<b>4 Revision History</b> .....	<b>2</b>	8.2 Typical Application .....	<b>19</b>
<b>5 Pin Configuration and Functions</b> .....	<b>3</b>	<b>9 Power Supply Recommendations</b> .....	<b>22</b>
<b>6 Specifications</b> .....	<b>4</b>	<b>10 Layout</b> .....	<b>22</b>
6.1 Absolute Maximum Ratings .....	<b>4</b>	10.1 Layout Guidelines .....	<b>22</b>
6.2 ESD Ratings.....	<b>4</b>	10.2 Layout Example .....	<b>22</b>
6.3 Recommended Operating Conditions.....	<b>4</b>	<b>11 Device and Documentation Support</b> .....	<b>23</b>
6.4 Thermal Information .....	<b>5</b>	11.1 Device Support.....	<b>23</b>
6.5 Electrical Characteristics.....	<b>5</b>	11.2 Documentation Support .....	<b>23</b>
6.6 Timing Requirements .....	<b>6</b>	11.3 Receiving Notification of Documentation Updates	<b>23</b>
6.7 Typical Characteristics .....	<b>8</b>	11.4 Community Resources.....	<b>23</b>
<b>7 Detailed Description</b> .....	<b>11</b>	11.5 Trademarks .....	<b>23</b>
7.1 Overview .....	<b>11</b>	11.6 Electrostatic Discharge Caution.....	<b>23</b>
7.2 Functional Block Diagram .....	<b>11</b>	11.7 Glossary .....	<b>24</b>
7.3 Feature Description.....	<b>12</b>	<b>12 Mechanical, Packaging, and Orderable Information</b> .....	<b>24</b>

## 4 Revision History

DATE	REVISION	NOTES
November 2016	*	Initial release.

## 5 Pin Configuration and Functions

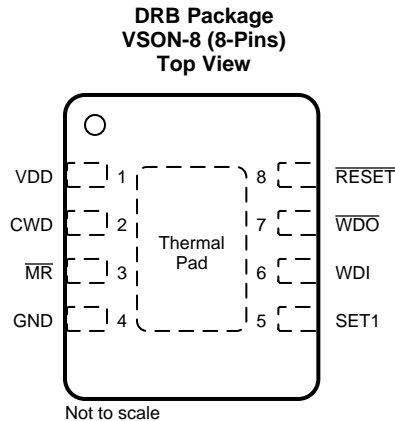

### Pin Functions

NAME	NO.	I/O	DESCRIPTION
CWD	2	—	Programmable watchdog timeout input. Watchdog timeout is set by connecting a capacitor between this pin and ground. Furthermore, this pin can also be connected by a 10-k $\Omega$ resistor to VDD, or leaving unconnected (NC) further enables the selection of the preset watchdog timeouts; see the <a href="#">Timing Requirements</a> table. When using a capacitor, the TPS3852 determines the window watchdog upper boundary with <a href="#">Equation 1</a> . See <a href="#">Table 3</a> and the <a href="#">CWD Functionality</a> section for additional information.
GND	4	—	Ground pin
$\overline{\text{MR}}$	3	I	Manual reset pin. A logical low on this pin issues a $\overline{\text{RESET}}$ . This pin is internally pulled up to VDD. $\overline{\text{RESET}}$ remains low for a fixed reset delay ( $t_{\text{RST}}$ ) time after $\overline{\text{MR}}$ is deasserted (high).
$\overline{\text{RESET}}$	8	O	Reset output. Connect $\overline{\text{RESET}}$ using a 1-k $\Omega$ to 100-k $\Omega$ resistor to the desired pullup voltage rail ( $V_{\text{PU}}$ ). $\overline{\text{RESET}}$ goes low when VDD goes below the undervoltage threshold ( $V_{\text{ITN}}$ ). When VDD is within the normal operating range, the $\overline{\text{RESET}}$ timeout-counter starts. At completion, $\overline{\text{RESET}}$ goes high. During startup, the state of $\overline{\text{RESET}}$ is undefined below the specified power-on-reset (POR) voltage ( $V_{\text{POR}}$ ). Above POR, $\overline{\text{RESET}}$ goes low and remains low until the monitored voltage is within the correct operating range (above $V_{\text{ITN}}+V_{\text{HYS}}$ ) and the $\overline{\text{RESET}}$ timeout is complete.
SET1	5	I	Logic input. Grounding the SET1 pin disables the watchdog timer.
VDD	1	I	Supply voltage pin. For noisy systems, connecting a 0.1- $\mu\text{F}$ bypass capacitor is recommended.
WDI	6	I	Watchdog input. A falling transition (edge) must occur at this pin between the lower ( $t_{\text{WDL(max)}}$ ) and upper ( $t_{\text{WDU(min)}}$ ) window boundaries in order for $\overline{\text{WDO}}$ to not assert. When the watchdog is not in use, the SET1 pin can be used to disable the watchdog. The input at WDI is ignored when $\overline{\text{RESET}}$ or $\overline{\text{WDO}}$ are low (asserted) and also when the watchdog is disabled. If the watchdog is disabled, then WDI cannot be left unconnected and must be driven to either VDD or GND.
$\overline{\text{WDO}}$	7	O	Watchdog output. Connect $\overline{\text{WDO}}$ with a 1-k $\Omega$ to 100-k $\Omega$ resistor to the desired pullup voltage rail ( $V_{\text{PU}}$ ). $\overline{\text{WDO}}$ goes low (asserts) when a watchdog timeout occurs. $\overline{\text{WDO}}$ only asserts when $\overline{\text{RESET}}$ is high. When a watchdog timeout occurs, $\overline{\text{WDO}}$ goes low (asserts) for the set $\overline{\text{RESET}}$ timeout delay ( $t_{\text{RST}}$ ). When $\overline{\text{RESET}}$ goes low, $\overline{\text{WDO}}$ is in a high-impedance state.
Thermal pad		—	Connect the thermal pad to a large-area ground plane. The thermal pad is internally connected to GND.

## 6 Specifications

### 6.1 Absolute Maximum Ratings

over operating free-air temperature range (unless otherwise noted)<sup>(1)</sup>

		MIN	MAX	UNIT
Supply voltage range	VDD	-0.3	7	V
Output voltage range	$\overline{\text{RESET}}$ , $\overline{\text{WDO}}$	-0.3	7	V
Voltage ranges	SET1, WDI, $\overline{\text{MR}}$	-0.3	7	V
	CWD, CRST	-0.3	$V_{\text{DD}} + 0.3^{(2)}$	V
Output pin current			±20	mA
Input current (all pins)			±20	mA
Continuous total power dissipation		See <a href="#">Thermal Information</a>		
Temperature	Operating junction, $T_J^{(3)}$	-40	150	°C
	Operating free-air temperature, $T_A^{(3)}$	-40	150	°C
	Storage, $T_{\text{stg}}$	-65	150	°C

- (1) Stresses beyond those listed under *Absolute Maximum Ratings* may cause permanent damage to the device. These are stress ratings only, which do not imply functional operation of the device at these or any other conditions beyond those indicated under *Recommended Operating Conditions*. Exposure to absolute-maximum-rated conditions for extended periods may affect device reliability.
- (2) The absolute maximum rating is  $V_{\text{DD}} + 0.3$  V or 7.0 V, whichever is smaller.
- (3) Assume that  $T_J = T_A$  as a result of the low dissipated power in this device.

### 6.2 ESD Ratings

		VALUE	UNIT
$V_{\text{(ESD)}}$ Electrostatic discharge	Human-body model (HBM), per ANSI/ESDA/JEDEC JS-001 <sup>(1)</sup>	±1000	V
	Charged-device model (CDM), per JEDEC specification JESD22-C101 <sup>(2)</sup>	±500	

- (1) JEDEC document JEP155 states that 500-V HBM allows safe manufacturing with a standard ESD control process.
- (2) JEDEC document JEP157 states that 250-V CDM allows safe manufacturing with a standard ESD control process.

### 6.3 Recommended Operating Conditions

over operating free-air temperature range (unless otherwise noted)

		MIN	NOM	MAX	UNIT
$V_{\text{DD}}$	Supply pin voltage	1.6		6.5	V
$V_{\text{SET1}}$	SET1 pin voltage	0		6.5	V
$V_{\overline{\text{MR}}}$	MR pin voltage	0		6.5	V
$C_{\text{CWD}}$	Watchdog timing capacitor	0.1 <sup>(1)</sup>		1000 <sup>(1)</sup>	nF
CWD	Pull-up resistor to VDD	9	10	11	kΩ
$R_{\text{PU}}$	Pull-up resistor, $\overline{\text{RESET}}$ and $\overline{\text{WDO}}$	1	10	100	kΩ
$I_{\overline{\text{RESET}}}$	$\overline{\text{RESET}}$ pin current			10	mA
$I_{\overline{\text{WDO}}}$	Watchdog output current			10	mA
$T_J$	Junction Temperature	-40		125	°C

- (1) Using a  $C_{\text{CWD}}$  capacitor of 0.1 nF or 1000 nF gives a  $t_{\text{WDU(typ)}}$  of 62.74 ms or 77.45 seconds, respectively.

## 6.4 Thermal Information

THERMAL METRIC <sup>(1)</sup>		TPS3852	UNIT
		DRB (VSON)	
		8 PINS	
R <sub>θJA</sub>	Junction-to-ambient thermal resistance	50.7	°C/W
R <sub>θJC(top)</sub>	Junction-to-case (top) thermal resistance	51.6	°C/W
R <sub>θJB</sub>	Junction-to-board thermal resistance	25.8	°C/W
ψ <sub>JT</sub>	Junction-to-top characterization parameter	1.3	°C/W
ψ <sub>JB</sub>	Junction-to-board characterization parameter	25.8	°C/W
R <sub>θJC(bot)</sub>	Junction-to-case (bottom) thermal resistance	7.1	°C/W

(1) For more information about traditional and new thermal metrics, see the [Semiconductor and IC Package Thermal Metrics](#) application report.

## 6.5 Electrical Characteristics

At  $V_{ITN} + V_{HYST} \leq V_{DD} \leq 6.5$  V over the operating temperature range of  $-40^{\circ}\text{C} \leq T_A, T_J \leq 125^{\circ}\text{C}$ , unless otherwise noted. The open-drain pull-up resistors are 10 kΩ for each output. Typical values are at  $T_J = 25^{\circ}\text{C}$ .

PARAMETER	TEST CONDITIONS	MIN	TYP	MAX	UNIT			
<b>GENERAL CHARACTERISTICS</b>								
V <sub>DD</sub> <sup>(1)</sup>	Supply voltage	1.6		6.5	V			
I <sub>DD</sub>	Supply Current		10	19	μA			
<b>RESET FUNCTION</b>								
V <sub>POR</sub> <sup>(2)</sup>	Power-on reset voltage	I <sub>RESET</sub> = 15 μA, V <sub>OL(MAX)</sub> = 0.25 V			0.8	V		
V <sub>UVLO</sub> <sup>(3)</sup>	Under Voltage Lock Out Voltage		1.35		V			
V <sub>ITN</sub>	Undervoltage threshold accuracy, entering RESET	V <sub>DD</sub> falling	V <sub>ITN</sub> - 0.8%	V <sub>ITN</sub> + 0.8%				
V <sub>HYST</sub>	Hysteresis voltage	V <sub>DD</sub> rising	0.2%	0.5%	0.8%			
I <sub>MR</sub>	MR pin internal pull-up current	V <sub>MR</sub> = 0 V	500	620	700	nA		
<b>WINDOW WATCHDOG FUNCTION</b>								
I <sub>CWD</sub>	CWD pin charge current	CWD = 0.5 V			337	375	413	nA
V <sub>CWD</sub>	CWD pin threshold voltage		1.192	1.21	1.228	V		
V <sub>OL</sub>	RESET, WDO output low	V <sub>DD</sub> = 5 V, I <sub>RESET</sub> = I <sub>WDO</sub> = 3 mA			0.4	V		
I <sub>D</sub>	RESET, WDO output leakage current, open-drain	V <sub>DD</sub> = V <sub>ITN</sub> + V <sub>HYST</sub> , V <sub>RESET</sub> = V <sub>WDO</sub> = 6.5 V			1	μA		
V <sub>IL</sub>	Low-level input voltage (MR, SET1)				0.25	V		
V <sub>IH</sub>	High-level input voltage (MR, SET1)		0.8			V		
V <sub>IL(WDI)</sub>	Low-level input voltage (WDI)				0.3 × V <sub>DD</sub>	V		
V <sub>IH(WDI)</sub>	High-level input voltage (WDI)		0.8 × V <sub>DD</sub>			V		

(1) During power on, V<sub>DD</sub> must be a minimum 1.6 V for at least 300 μs before RESET correlates with V<sub>DD</sub>.

(2) When V<sub>DD</sub> falls below V<sub>POR</sub>, RESET and WDO are undefined.

(3) When V<sub>DD</sub> falls below UVLO, RESET is driven low.

### 6.6 Timing Requirements

At  $V_{ITN} + V_{HYST} \leq V_{DD} \leq 6.5\text{ V}$  over the operating temperature range of  $-40^{\circ}\text{C} \leq T_A, T_J \leq 125^{\circ}\text{C}$ , unless otherwise noted. The open-drain pull-up resistors are 10 kΩ for each output. Typical values are at  $T_J = 25^{\circ}\text{C}$ .

		MIN	TYP	MAX	UNIT	
$t_{INIT}$	CWD pin evaluation period		381		μs	
	Minimum $\overline{\text{MR}}$ , SET1 pin pulse duration		1		μs	
	Startup delay		300		μs	
<b>RESET FUNCTION</b>						
$t_{RST}$	Reset timeout period	170	200	230	ms	
$t_{RST-DEL}$	$V_{DD}$ to $\overline{\text{RESET}}$ delay	$V_{DD} = V_{ITN} + V_{HYST} + 2.5\%$	35		μs	
		$V_{DD} = V_{ITN} - 2.5\%$	17			
$t_{MR-DEL}$	$\overline{\text{MR}}$ to $\overline{\text{RESET}}$ delay		200		ns	
<b>Watchdog Function</b>						
$t_{WDL}$	Window watchdog lower boundary	CWD = NC, SET1 = 0 <sup>(1)</sup>	Watchdog disabled			
		CWD = NC, SET1 = 1 <sup>(1)</sup>	680	800	920	ms
		CWD = 10kΩ to VDD, SET1 = 0 <sup>(1)</sup>	Watchdog disabled			
		CWD = 10kΩ to VDD, SET1 = 1 <sup>(1)</sup>	1.5	1.85	2.2	ms
$t_{WDU}$	Window watchdog upper boundary	CWD = NC, SET1 = 0 <sup>(1)</sup>	Watchdog disabled			
		CWD = NC, SET1 = 1 <sup>(1)</sup>	1360	1600	1840	ms
		CWD = 10kΩ to VDD, SET1 = 0 <sup>(1)</sup>	Watchdog disabled			
		CWD = 10kΩ to VDD, SET1 = 1 <sup>(1)</sup>	9.3	11.0	12.7	ms
$t_{WD-setup}$	Setup time required for part to respond to changes on WDI after being enabled		150		μs	
		Minimum WDI pulse width		50	ns	
$t_{WD-DEL}$	WDI to $\overline{\text{WDO}}$ Delay		50		ns	

(1) SET1 = 0 means  $V_{SET1} < V_{IL}$ , SET1 = 1 means  $V_{SET1} > V_{IH}$

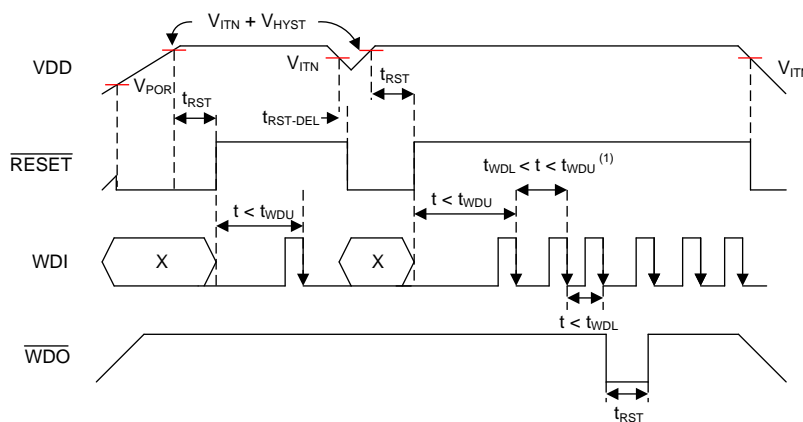

(1) See Figure 2 for WDI timing requirements.

Figure 1. Timing Diagram

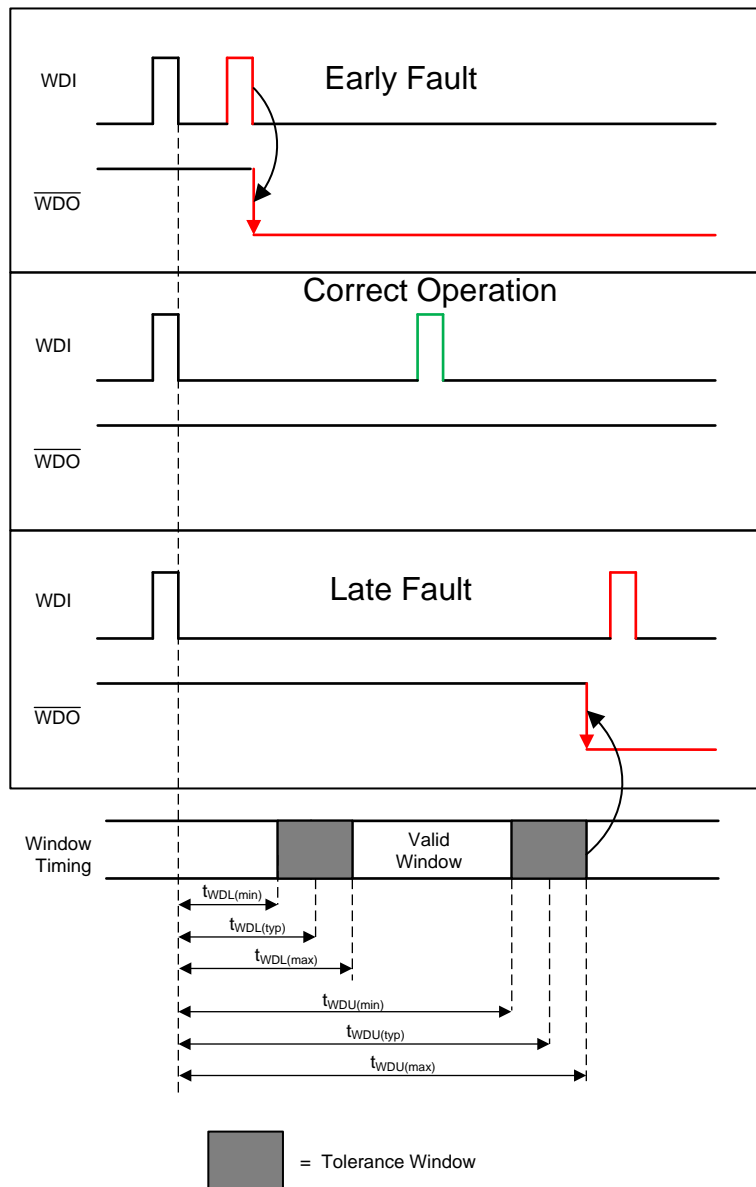

Figure 2. TPS3852 Window Watchdog Timing

### 6.7 Typical Characteristics

All Typical Characteristics curves are taken at 25°C with, 1.6 V ≤ VDD ≤ 6.5 V unless other wise noted.

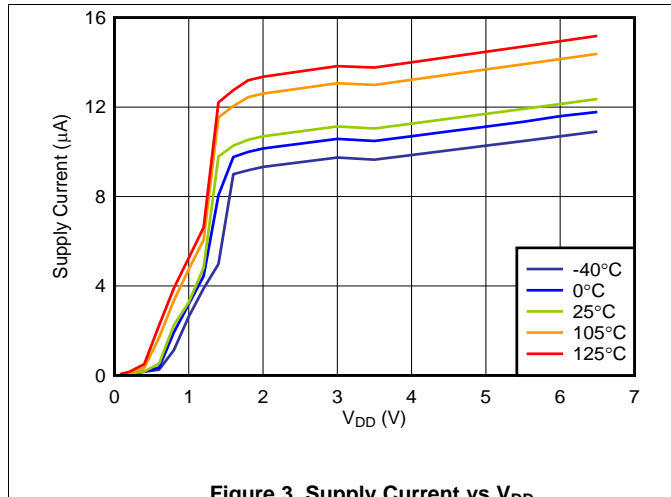

Figure 3. Supply Current vs VDD

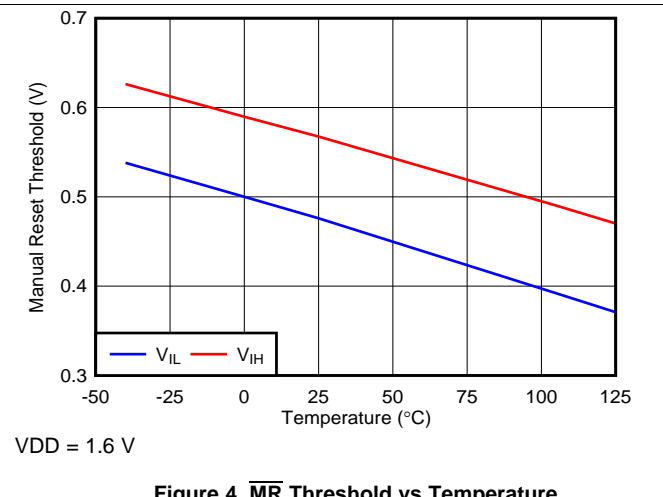

Figure 4. MR Threshold vs Temperature

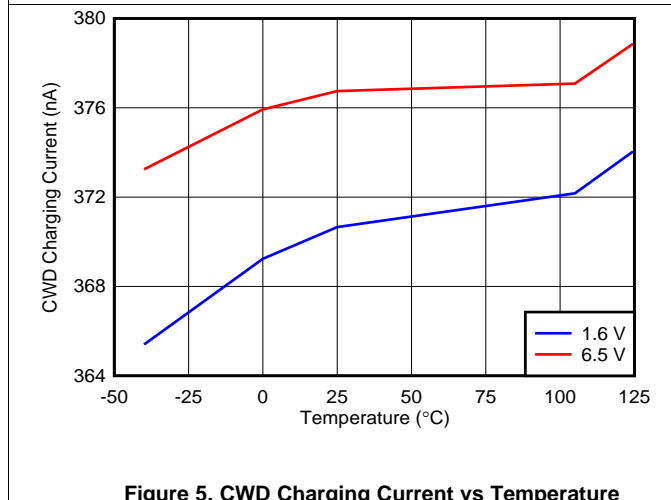

Figure 5. CWD Charging Current vs Temperature

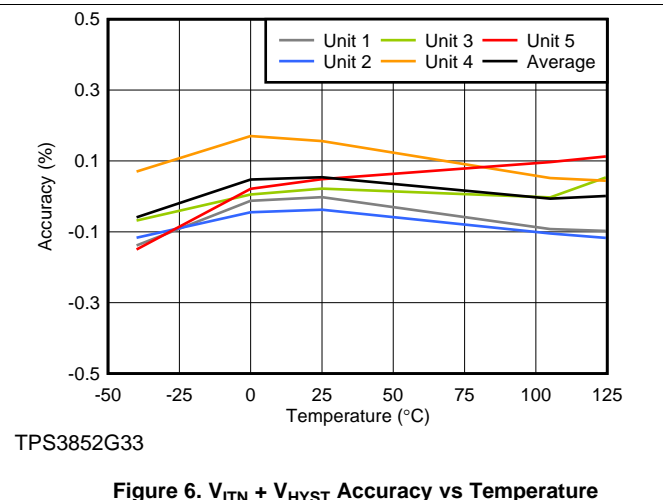

Figure 6. VITN + VHYS Accuracy vs Temperature

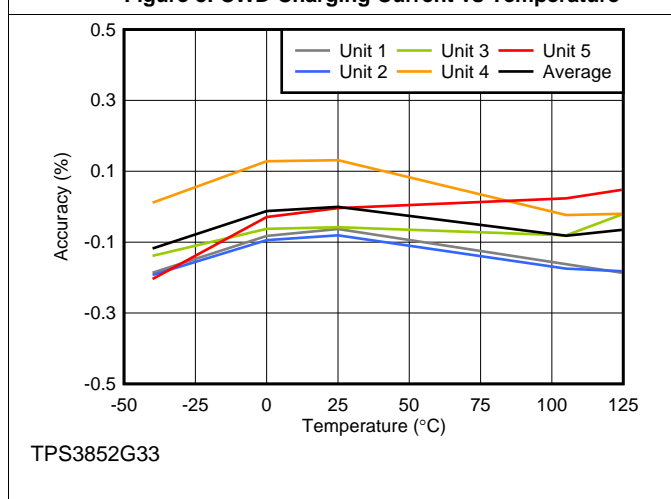

Figure 7. VITN Accuracy vs Temperature

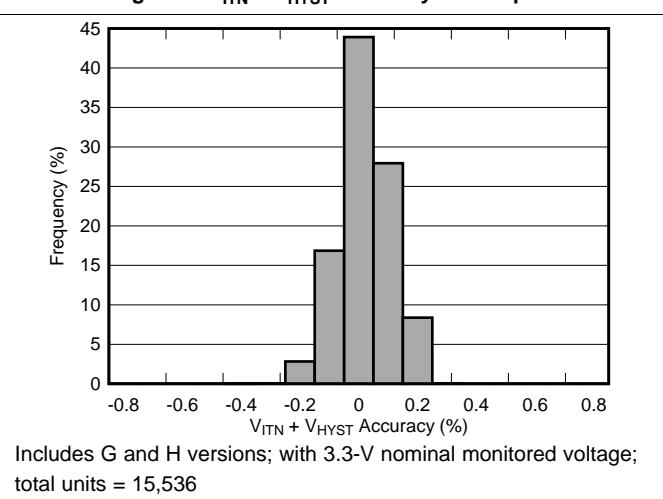
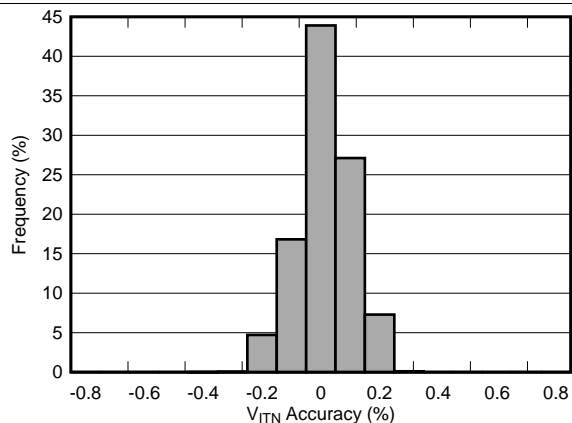

Figure 8. VITN + VHYS Accuracy Histogram

Includes G and H versions; with 3.3-V nominal monitored voltage; total units = 15,536

### Typical Characteristics (continued)

All Typical Characteristics curves are taken at 25°C with, 1.6 V ≤ VDD ≤ 6.5 V unless other wise noted.



Includes G and H versions; with 3.3-V nominal monitored voltage; total units = 15,536

Figure 9.  $V_{ITN}$  Accuracy Histogram

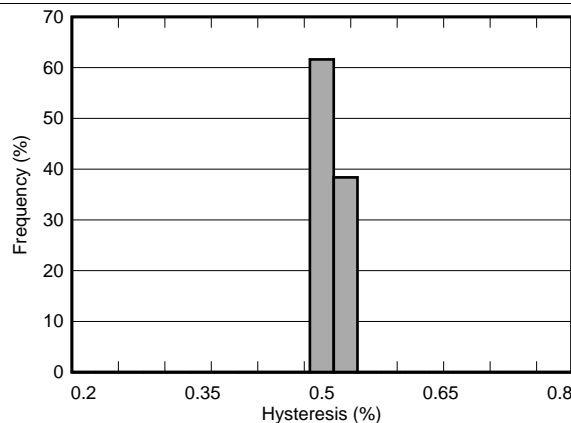

Includes G and H versions; with 3.3-V nominal monitored voltage; total units = 15,536

Figure 10. Hysteresis Histogram

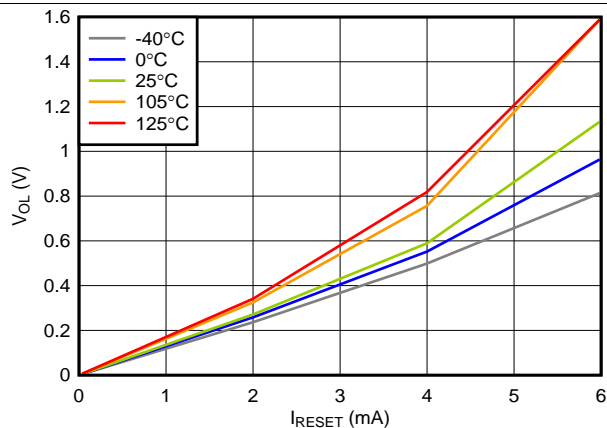

VDD = 1.6 V

Figure 11. Low-Level  $\overline{\text{RESET}}$  Voltage vs  $\overline{\text{RESET}}$  Current

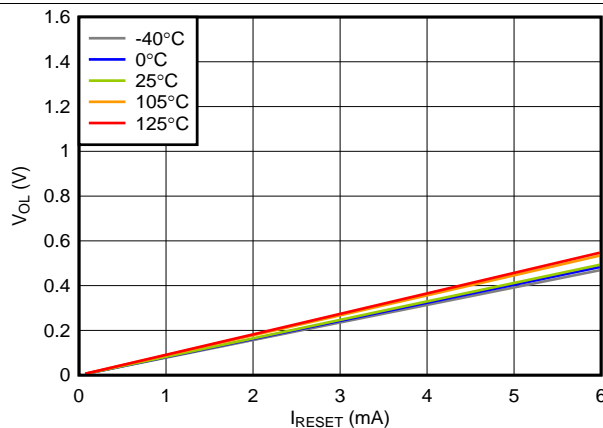

VDD = 6.5 V

Figure 12. Low-Level  $\overline{\text{RESET}}$  Voltage vs  $\overline{\text{RESET}}$  Current

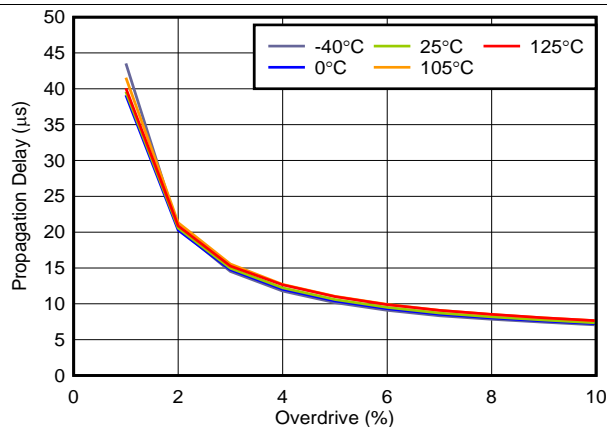

TPS3852G33 entering undervoltage

Figure 13. Propagation Delay vs Overdrive

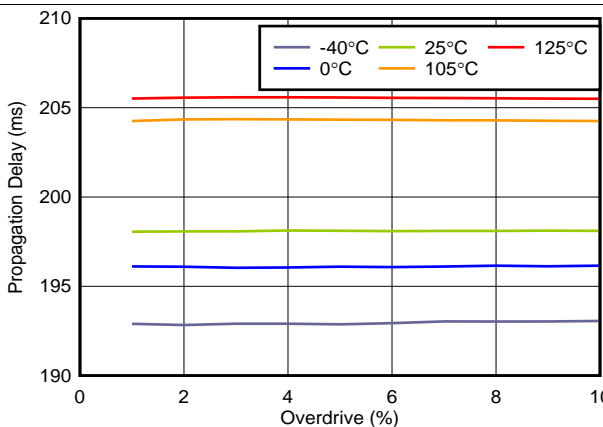

TPS3852G33 exiting undervoltage

Figure 14. Propagation Delay ( $t_{RST}$ ) vs Overdrive

**Typical Characteristics (continued)**

All Typical Characteristics curves are taken at 25°C with, 1.6 V ≤ VDD ≤ 6.5 V unless other wise noted.

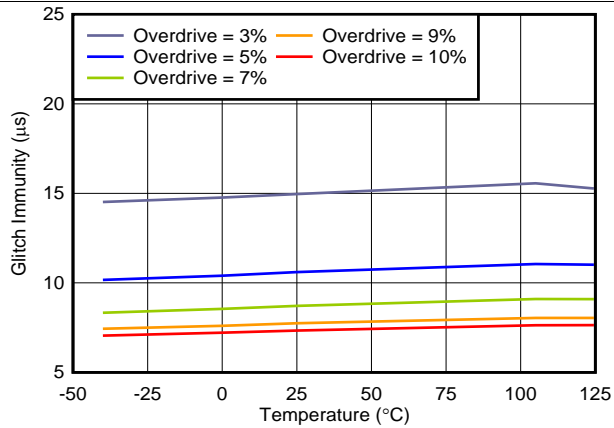

V<sub>ITN</sub> = 3.168 V

**Figure 15. High to Low Glitch Immunity vs Temperature**

## 7 Detailed Description

### 7.1 Overview

The TPS3852 is a high-accuracy voltage supervisor with an integrated window watchdog timer. This device includes a precision undervoltage supervisor with a threshold that achieves 0.8% accuracy over the specified temperature range of  $-40^{\circ}\text{C}$  to  $+125^{\circ}\text{C}$ . In addition, the TPS3852 includes accurate hysteresis on the threshold, making the device ideal for use with tight tolerance systems where voltage supervisors must ensure a  $\overline{\text{RESET}}$  before the minimum supply tolerance of the microprocessor or system-on-a-chip (SoC) is reached.

### 7.2 Functional Block Diagram

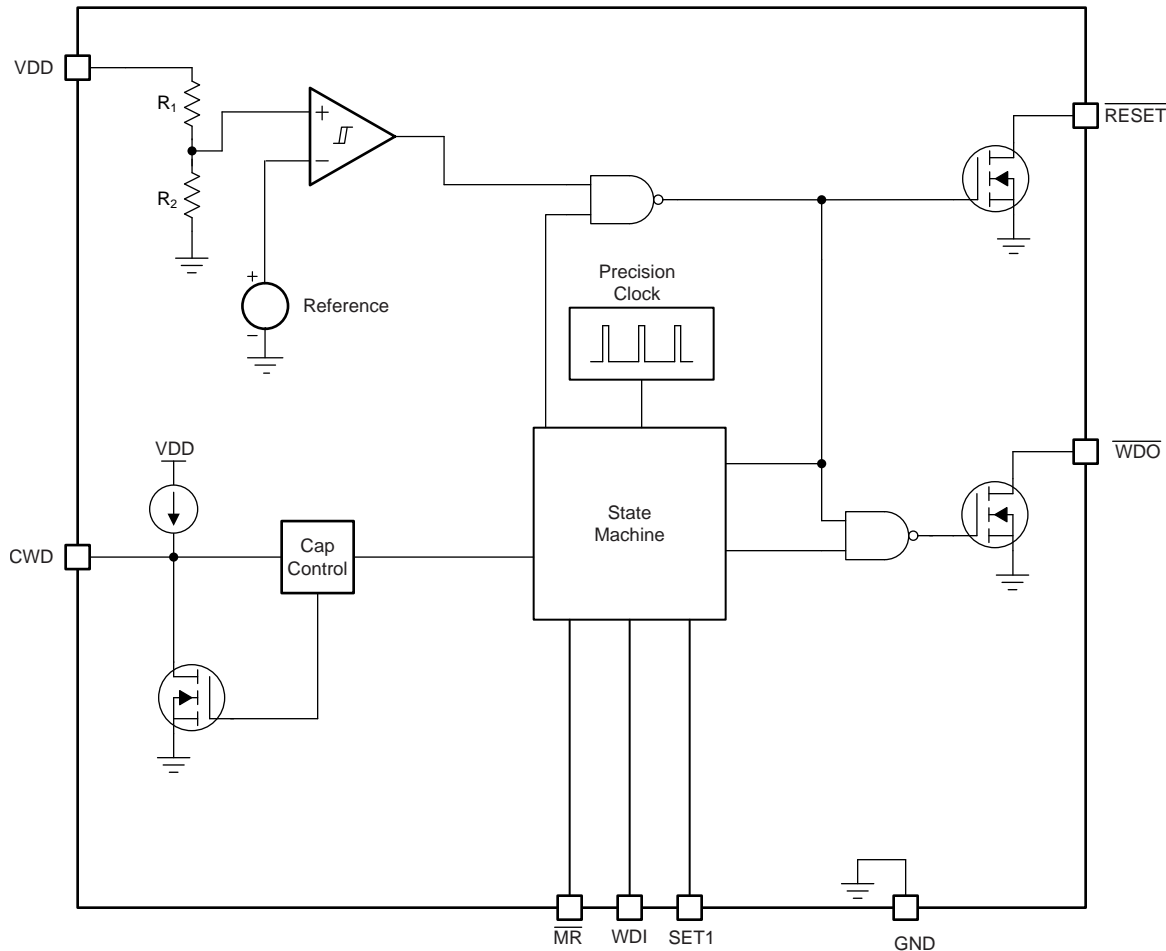

Copyright © 2016, Texas Instruments Incorporated

(1) Note:  $R_1 + R_2 = 4.5\text{M}\Omega$

## 7.3 Feature Description

### 7.3.1 RESET

Connect  $\overline{\text{RESET}}$  to  $V_{\text{PU}}$  through a 1-k $\Omega$  to 100-k $\Omega$  pullup resistor.  $\overline{\text{RESET}}$  remains high (deasserted) when  $V_{\text{DD}}$  is greater than the negative threshold voltage ( $V_{\text{ITN}}$ ). If  $V_{\text{DD}}$  falls below the negative threshold ( $V_{\text{ITN}}$ ), then  $\overline{\text{RESET}}$  is asserted, driving the  $\overline{\text{RESET}}$  pin to low impedance. When  $V_{\text{DD}}$  rises above  $V_{\text{ITN}} + V_{\text{HYST}}$ , a delay circuit is enabled that holds  $\overline{\text{RESET}}$  low for a specified reset delay period ( $t_{\text{RST}}$ ). When the reset delay has elapsed, the  $\overline{\text{RESET}}$  pin goes to a high-impedance state and uses a pullup resistor to hold  $\overline{\text{RESET}}$  high. The pullup resistor must be connected to the desired voltage rail to allow other devices to be connected at the correct interface voltage. To ensure proper voltage levels, give some consideration when choosing the pullup resistor values. The pullup resistor value is determined by output logic low voltage ( $V_{\text{OL}}$ ), leakage current ( $I_{\text{D}}$ ), and the current through the  $\overline{\text{RESET}}$  pin  $I_{\text{RESET}}$ .

### 7.3.2 Manual Reset $\overline{\text{MR}}$

The manual reset ( $\overline{\text{MR}}$ ) input allows a processor or other logic circuits to initiate a reset. A logic low on  $\overline{\text{MR}}$  causes  $\overline{\text{RESET}}$  to assert. After  $\overline{\text{MR}}$  returns to a logic high and  $V_{\text{DD}}$  is above  $V_{\text{ITN}} + V_{\text{HYST}}$ ,  $\overline{\text{RESET}}$  is deasserted after the reset delay time ( $t_{\text{RST}}$ ). If  $\overline{\text{MR}}$  is not controlled externally, then  $\overline{\text{MR}}$  can either be connected to  $V_{\text{DD}}$  or left floating because the  $\overline{\text{MR}}$  pin is internally pulled up. When  $\overline{\text{MR}}$  is asserted, the watchdog is disabled and all signals input to WDI are ignored.

### 7.3.3 UV Fault Detection

The TPS3852 features undervoltage detection for common rails between 1.8 V and 5 V. The voltage is monitored on the input rail of the device. If  $V_{\text{DD}}$  drops below  $V_{\text{ITN}}$ , then  $\overline{\text{RESET}}$  is asserted (driven low). When  $V_{\text{DD}}$  is above  $V_{\text{ITN}} + V_{\text{HYST}}$ ,  $\overline{\text{RESET}}$  deasserts after  $t_{\text{RST}}$ , as shown in Figure 16. The internal comparator has built-in hysteresis that provides some noise immunity and ensures stable operation. Although not required in most cases, for noisy applications, good analog design practice is to place a 1-nF to 100-nF bypass capacitor close to the VDD pin to reduce sensitivity to transient voltages on the monitored signal.

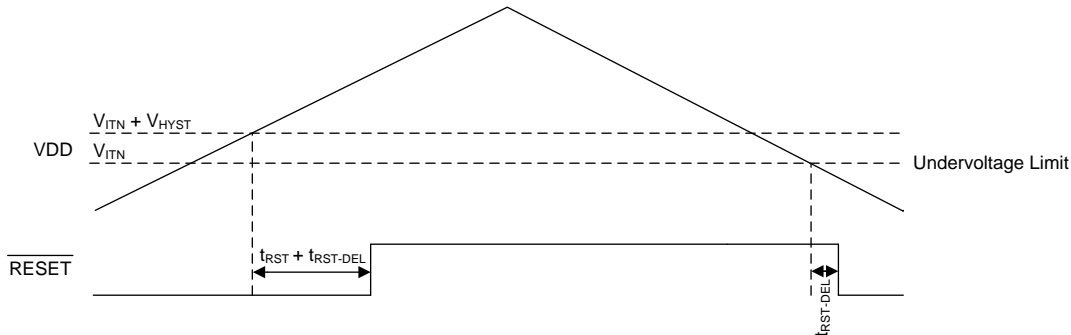

**Figure 16. Undervoltage Detection**

### 7.3.4 Watchdog Mode

This section provides information for the watchdog mode of operation.

#### 7.3.4.1 SET1

The SET1 pin can enable and disable the watchdog timer. If SET1 is set to GND, the watchdog timer is disabled and WDI is ignored. When the watchdog is disabled  $\overline{\text{WDO}}$  will be in a high impedance state. If the watchdog timer is disabled, drive the WDI pin to either GND or VDD to ensure that there is no increase in  $I_{\text{DD}}$ . When SET1 is logic high, the watchdog operates normally. The SET1 pin can be changed dynamically; however, if the watchdog is going from disabled to enabled there is a setup time  $t_{\text{WD-setup}}$  where the watchdog does not respond to changes on WDI, as shown in Figure 17.

## Feature Description (continued)

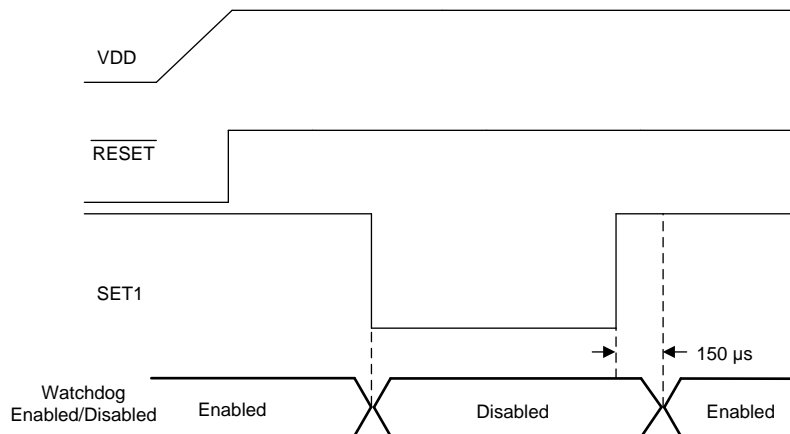

Figure 17. Enabling and Disabling the Watchdog

### 7.3.4.2 Window Watchdog Timer

This section provides information for the window watchdog mode of operation. A window watchdog is typically employed in safety critical applications where a traditional watchdog timer is inadequate. In a traditional watchdog there is a maximum time in which a pulse must be issued to prevent the reset from occurring. In a window watchdog the pulse must be issued between a maximum lower window time ( $t_{WDL(max)}$ ) and the minimum upper window time ( $t_{WDU(min)}$ ) set by the CWD pin.

### 7.3.4.3 Watchdog Input WDI

WDI is the watchdog timer input that controls the  $\overline{WDO}$  output. The WDI input is triggered by the falling edge of the input signal. For the first pulse, the watchdog acts as a traditional watchdog timer; thus, the first pulse must be issued before  $t_{WDU(min)}$ . After the first pulse, to ensure proper functionality of the watchdog timer, always issue the WDI pulse within the window of  $t_{WDL(max)}$  and  $t_{WDU(min)}$ . If the pulse is issued in this region, then  $\overline{WDO}$  remains unasserted. Otherwise, the device asserts  $\overline{WDO}$ , putting the  $\overline{WDO}$  pin into a low-impedance state.

The watchdog input (WDI) is a digital pin. In order to ensure there is no increase in  $I_{DD}$ , drive the WDI pin to either VDD or GND at all times. Putting the pin to an intermediate voltage can cause an increase in supply current ( $I_{DD}$ ) because of the architecture of the digital logic gates. When RESET is asserted, the watchdog is disabled and all signals input to WDI are ignored. When RESET is no longer asserted, the device resumes normal operation and no longer ignores the signal on WDI. If the watchdog is disabled, drive the WDI pin to either VDD or GND.

### 7.3.4.4 CWD

The CWD pin provides the user the functionality of both high precision factory programmed window watchdog timing options and user programmable window watchdog timing. The CWD pin can be either pulled-up to VDD through a resistor, have an external capacitor to ground, or be left floating. Every time that the part issues a reset event and the supply voltage is above  $V_{ITN}$  the part will try to determine, which of these three options is connected to the pin. There is an internal state machine that the device goes through to determine which option is connected to the CWD pin. The state machine can take up to 381 µs to determine if the CWD pin is left floating, pulled-up through a resistor, or connected to a capacitor.

If the CWD pin is being pulled up to VDD using a pull-up resistor then a 10-kΩ resistor should be used.

## Feature Description (continued)

### 7.3.4.5 Watchdog Output $\overline{WDO}$

The TPS3852 features a window watchdog with an independent watchdog output ( $\overline{WDO}$ ). The independent watchdog output gives the flexibility to flag when there is a fault in the watchdog timing without performing an entire system reset. For legacy applications  $\overline{WDO}$  can be tied to  $\overline{RESET}$ . While the  $\overline{RESET}$  output is not asserted the  $\overline{WDO}$  signal will maintain normal operation. However, when the  $\overline{RESET}$  signal is asserted the  $\overline{WDO}$  pin will go into a high impedance state. This is due to using the standard  $\overline{RESET}$  timing options when a fault occurs on  $\overline{WDO}$ . Once  $\overline{RESET}$  is unasserted the window watchdog timer will resume normal operation.

## 7.4 Device Functional Modes

Table 1 summarises the functional modes of TPS3852.

**Table 1. Device Functional Modes**

$V_{DD}$	WDI	$\overline{WDO}$	$\overline{RESET}$
$V_{DD} < V_{POR}$	—	—	Undefined
$V_{POR} \leq V_{DD} < V_{DD(min)}$	Ignored	High	Low
$V_{DD(min)} \leq V_{DD} \leq V_{ITN} + V_{HYST}^{(1)}$	Ignored	High	Low
$V_{DD} > V_{ITN}^{(2)}$	$t_{WDL(max)} < t_{PULSE} < t_{WDU(min)}^{(3)}$	High	High
	$t_{PULSE} > t_{WDU(min)}^{(3)}$	Low	High
	$t_{PULSE} < t_{WDL(max)}^{(3)}$	Low	High

(1) Only valid before  $V_{DD}$  has gone above  $V_{ITN} + V_{HYST}$

(2) Only valid after  $V_{DD}$  has gone above  $V_{ITN} + V_{HYST}$

(3) Where  $t_{PULSE}$  is the time between falling edges on WDI

### 7.4.1 $V_{DD}$ is Below $V_{POR}$ ( $V_{DD} < V_{POR}$ )

When  $V_{DD}$  is less than  $V_{POR}$ ,  $\overline{RESET}$  is undefined and can be either high or low. The state of  $\overline{RESET}$  largely depends on the load that the  $\overline{RESET}$  pin is experiencing.

### 7.4.2 Above Power-On-Reset, But Less Than $V_{DD(min)}$ ( $V_{POR} \leq V_{DD} < V_{DD(min)}$ )

When the voltage on  $V_{DD}$  is less than  $V_{DD(min)}$ , and greater than or equal to  $V_{POR}$ , the  $\overline{RESET}$  signal is asserted (logic low). When  $\overline{RESET}$  is asserted, the watchdog output  $\overline{WDO}$  is in a high-impedance state regardless of the WDI signal that is input to the device.

### 7.4.3 Normal Operation ( $V_{DD} \geq V_{DD(min)}$ )

When  $V_{DD}$  is greater than or equal to  $V_{DD(min)}$ , the  $\overline{RESET}$  signal is determined by  $V_{DD}$ . When  $\overline{RESET}$  is asserted,  $\overline{WDO}$  goes to a high-impedance state.  $\overline{WDO}$  is then pulled high through the pullup resistor.

## 8 Application and Implementation

### NOTE

Information in the following applications sections is not part of the TI component specification, and TI does not warrant its accuracy or completeness. TI's customers are responsible for determining suitability of components for their purposes. Customers should validate and test their design implementation to confirm system functionality.

### 8.1 Application Information

#### 8.1.1 CWD Functionality

The TPS3852 features three options for setting the watchdog window: connecting a capacitor to the CWD pin, connecting a pullup resistor to VDD, and leaving the CWD pin unconnected. Figure 18 shows a schematic drawing of all three options. If this pin is connected to VDD through a 10-kΩ pullup resistor or left unconnected (high impedance), then the factory-programmed watchdog timeouts are enabled; see the [Timing Requirements](#) table. Otherwise, the watchdog timeout can be adjusted by placing a capacitor from the CWD pin to ground.

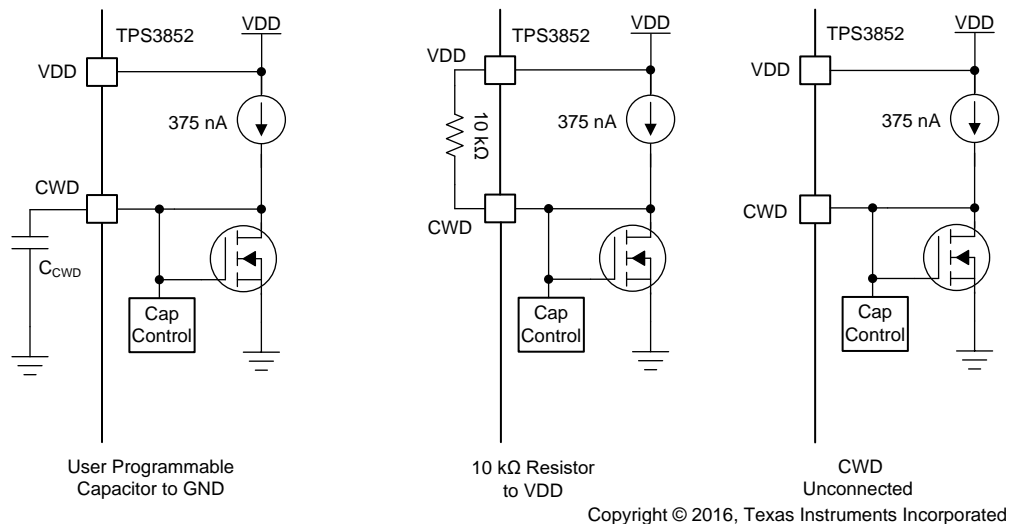

Figure 18. CWD Charging Circuit

##### 8.1.1.1 Factory-Programmed Timing Options

If using the factory-programmed timing options (listed in Table 2), the CWD pin must either be unconnected or pulled up to VDD through a 10-kΩ pullup resistor. Using these options enables high-precision, 15% accurate watchdog timing.

Table 2. Factory-Programmed Watchdog Timing

INPUT		WATCHDOG LOWER BOUNDARY ( $t_{WDL}$ )			WATCHDOG UPPER BOUNDARY ( $t_{WDU}$ )			UNIT
CWD	SET1	MIN	TYP	MAX	MIN	TYP	MAX	
NC	0	Watchdog disabled			Watchdog disabled			
	1	680	800	920	1360	1600	1840	ms
10 kΩ to VDD	0	Watchdog disabled			Watchdog disabled			
	1	1.5	1.85	2.2	8.8	11.0	13.2	ms

### 8.1.1.2 Adjustable Capacitor Timing

Adjustable capacitor timing is achievable by connecting a capacitor to the CWD pin. If a capacitor is connected to CWD, then a 375-nA current source charges  $C_{CWD}$  until  $V_{CWD} = 1.21$  V. The TPS3852 determines the window watchdog upper boundary with the formula given in Equation 1, where  $C_{CWD}$  is in microfarads ( $\mu\text{F}$ ) and  $t_{WDU}$  is in seconds.

$$t_{WDU(\text{typ})}(\text{s}) = 77.4 \times C_{CWD}(\mu\text{F}) + 0.055(\text{s}) \quad (1)$$

The TPS3852 is limited to using  $C_{CWD}$  capacitors between 100 pF and 1  $\mu\text{F}$ . Note that Equation 1 is for ideal capacitors, capacitor tolerances cause the actual device timing to vary. For the most accurate timing, use ceramic capacitors with COG dielectric material. As shown in Table 4, when using the minimum capacitance of 100 pF, the watchdog upper boundary is 62.74 ms; whereas with a 1- $\mu\text{F}$  capacitance, the watchdog upper boundary is 77.455 seconds. If a  $C_{CWD}$  capacitor is used, Equation 1 can be used to set  $t_{WDU}$  the window watchdog upper boundary. Table 3 shows how  $t_{WDL}$  can be used to calculate  $t_{WDL}$ .

**Table 3. Programmable CWD Timing**

INPUT		WATCHDOG LOWER BOUNDARY ( $t_{WDL}$ )			WATCHDOG UPPER BOUNDARY ( $t_{WDU}$ )			UNIT
CWD	SET1	MIN	TYP	MAX	MIN	TYP	MAX	
$C_{CWD}$	0	Watchdog disabled			Watchdog disabled			s
	1	$t_{WDL(\text{min})} \times 0.5$	$t_{WDL} \times 0.5$	$t_{WDL(\text{max})} \times 0.5$	$0.85 \times t_{WDU(\text{typ})}$	$t_{WDU(\text{typ})}^{(1)}$	$1.15 \times t_{WDU(\text{typ})}$	

(1) Calculated from Equation 1 using ideal capacitors.

**Table 4.  $t_{WDU}$  Values for Common Ideal Capacitor Values**

$C_{CWD}$	WATCHDOG UPPER BOUNDARY ( $t_{WDU}$ )			UNIT
	MIN <sup>(1)</sup>	TYP	MAX <sup>(1)</sup>	
100 pF	53.32	62.74	72.15	ms
1 nF	112.5	132.4	152.2	ms
10 nF	704	829	953	ms
100 nF	6625	7795	8964	ms
1 $\mu\text{F}$	65836	77455	89073	ms

(1) Minimum and maximum values are calculated using ideal capacitors.

### 8.1.2 Overdrive Voltage

Forcing a  $\overline{\text{RESET}}$  is dependent on two conditions: the amplitude  $V_{DD}$  is beyond the trip point ( $\Delta V_1$  and  $\Delta V_2$ ), and the length of time that the voltage is beyond the trip point for a long period of time,  $\overline{\text{RESET}}$  asserts and the output is pulled low. However, if  $V_{DD}$  is just under the trip point for a few nanoseconds,  $\overline{\text{RESET}}$  does not assert and the output remains high. The length of time required for  $\overline{\text{RESET}}$  to assert can be changed by increasing the amount  $V_{DD}$  goes under the trip point. If  $V_{DD}$  is under the trip point by 10%, the amount of time required for the comparator to respond is much faster and causes  $\overline{\text{RESET}}$  to assert much quicker than when barely under the trip point voltage. Equation 2 shows how to calculate the percentage overdrive.

$$\text{Overdrive} = |(V_{DD} / V_{ITX} - 1) \times 100\%| \quad (2)$$

In Equation 2,  $V_{ITX}$  corresponds to the threshold trip point. If  $V_{DD}$  is exceeding the positive threshold,  $V_{ITN} + V_{HYST}$  is used.  $V_{ITN}$  is used when  $V_{DD}$  is falling below the negative threshold. In Figure 19,  $t_1$  and  $t_2$  correspond to the amount of time that  $V_{DD}$  is over the threshold; the propagation delay versus overdrive for  $V_{ITN}$  and  $V_{ITN} + V_{HYST}$  is illustrated in Figure 13 and Figure 14, respectively.

The TPS3852 is relatively immune to short positive and negative transients on VDD because of the overdrive voltage.

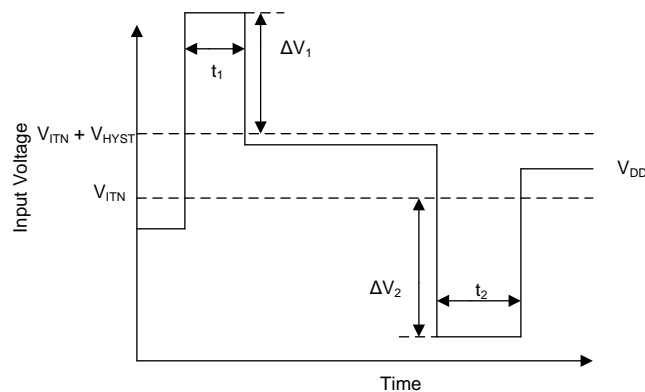

Copyright © 2016, Texas Instruments Incorporated

**Figure 19. Overdrive Voltage**

## 8.2 Typical Application

A typical application for the TPS3852 is shown in Figure 20. The TPS3852G33 is used to monitor the 3.3-V, V<sub>CORE</sub> rail powering the microcontroller.

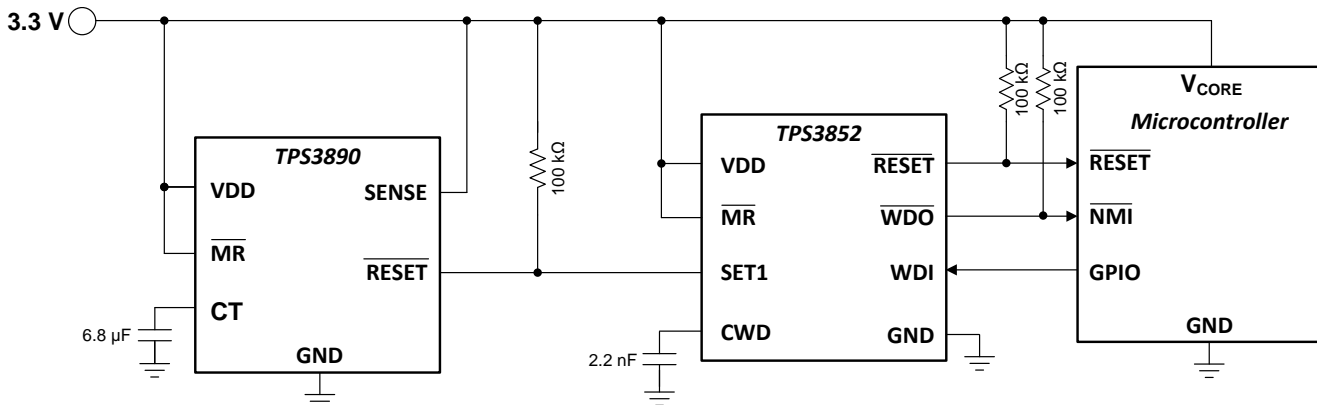

Copyright © 2016, Texas Instruments Incorporated

Figure 20. Monitoring Supply Voltage and Watchdog Supervision of a Microcontroller

### 8.2.1 Design Requirements

Parameter	Design Requirement	Design Result
Watchdog Disable For Initialization Period	Watchdog must remain disabled for 7 seconds until logic enables the watchdog timer	7.21 seconds (typ)
Output Logic Voltage	3.3V CMOS	3.3V CMOS
Monitored Rail	3.3 V with a 5% threshold	Worst Case V <sub>ITN</sub> = 3.142 V (- 4.7% threshold)
Watchdog Window	250 ms, maximum	t <sub>WDL(max)</sub> = 135 ms, t <sub>WDU(min)</sub> = 181 ms
Maximum Device Current Consumption	50 uA	52 uA (worst case) when $\overline{\text{RESET}}$ or $\overline{\text{WDO}}$ is asserted <sup>(1)</sup>

(1) Only includes the TPS3852G33 current consumption.

### 8.2.2 Detailed Design Procedure

#### 8.2.2.1 Monitoring the 3.3V Rail

This application calls for very tight monitoring of the rail with only 5% of variation allowed on the rail. To ensure this requirement is met, the TPS3852G33 was chosen for its -4% threshold. To calculate the worst-case for V<sub>ITN</sub>, the accuracy must also be taken into account. The worst-case for V<sub>ITN</sub> can be calculated by Equation 3:

$$V_{ITN(\text{Worst Case})} = V_{ITN(\text{typ})} \times 0.992 = 3.3 \times 0.96 \times 0.992 = 3.142 \text{ V} \quad (3)$$

### 8.2.2.2 Calculating $\overline{\text{RESET}}$ and $\overline{\text{WDO}}$ Pullup Resistor

The TPS3852 uses an open-drain configuration for the  $\overline{\text{RESET}}$  circuit, as shown in Figure 21. When the FET is off, the resistor pulls the drain of the transistor to VDD and when the FET is turned on, the FET attempts to pull the drain to ground, thus creating an effective resistor divider. The resistors in this divider must be chosen to ensure that  $V_{OL}$  is below the maximum value. To choose the proper pullup resistor, there are three key specifications to keep in mind: the pullup voltage ( $V_{PU}$ ), the recommended maximum  $\overline{\text{RESET}}$  pin current ( $I_{\overline{\text{RESET}}}$ ), and  $V_{OL}$ . The maximum  $V_{OL}$  is 0.4 V, meaning that the effective resistor divider created must be able to bring the voltage on the reset pin below 0.4 V with  $I_{\overline{\text{RESET}}}$  kept below 10 mA. For this example, with a  $V_{PU}$  of 3.3 V, a resistor must be chosen to keep  $I_{\overline{\text{RESET}}}$  below 50  $\mu\text{A}$  because this value is the maximum consumption current allowed. To ensure this specification is met, a pullup resistor value of 100 k $\Omega$  was selected, which sinks a maximum of 33  $\mu\text{A}$  when  $\overline{\text{RESET}}$  or  $\overline{\text{WDO}}$  is asserted. As illustrated in Figure 11, when the  $\overline{\text{RESET}}$  current is at 33  $\mu\text{A}$  and the low-level output voltage is approximately zero.

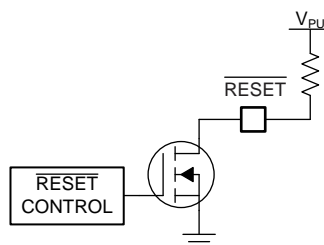

Copyright © 2016, Texas Instruments Incorporated

Figure 21.  $\overline{\text{RESET}}$  Open-Drain Configuration

### 8.2.2.3 Setting the Window Watchdog

As illustrated in Figure 18, there are three options for setting the window watchdog. The design specifications in this application require the programmable timing option (external capacitor connected to CWD). When a capacitor is connected to the CWD pin, the window is governed by Equation 4. Equation 4 is only valid for ideal capacitors, any temperature or voltage derating must be accounted for separately.

$$C_{\text{CWD}} (\mu\text{F}) = \frac{t_{\text{WDU}} - 0.055}{77.4} = \frac{0.25 - 0.055}{77.4} = 0.0025 \mu\text{F} \tag{4}$$

The nearest standard capacitor value to 2.5 nF is 2.2 nF. Selecting 2.2 nF for the  $C_{\text{CWD}}$  capacitor gives the following minimum and maximum timing parameters:

$$t_{\text{WDU}(\text{MIN})} = 0.85 \times t_{\text{WDU}(\text{TYP})} = 0.85 \times (77.4 \times 2.2 \times 10^{-3} + 0.055) = 191 \text{ ms} \tag{5}$$

$$t_{\text{WDL}(\text{MAX})} = 0.5 \times t_{\text{WDU}(\text{MAX})} = 0.5 \times [1.15 \times (77.4 \times 2.2 \times 10^{-3} + 0.055)] = 129 \text{ ms} \tag{6}$$

Capacitor tolerance also influence  $t_{\text{WDU}(\text{MIN})}$  and  $t_{\text{WDL}(\text{MAX})}$ . Select a ceramic COG dielectric capacitor for high accuracy. For 2.2 nF, COG capacitors are readily available with a 5% tolerance, which results in a 5% decrease in  $t_{\text{WDU}(\text{MIN})}$  and a 5% increase in  $t_{\text{WDL}(\text{MAX})}$ , giving 181 ms and 135 ms, respectively. A falling edge must be issued within this window.

### 8.2.2.4 Watchdog Disabled During Initialization Period

The watchdog is often needed to be disabled during startup to allow for an initialization period. When the initialization period is over, the watchdog timer is turned back on to allow the microcontroller to be monitored by the TPS3852. To achieve this setup SET1 must start at GND. In this design, SET1 is controlled by a TPS3890 supervisor. In this application, the TPS3890 was chosen to monitor  $V_{\text{DD}}$  as well, which means that  $\overline{\text{RESET}}$  on the TPS3890 stays low until  $V_{\text{DD}}$  rises above  $V_{\text{ITN}}$ . When  $V_{\text{DD}}$  comes up, the delay time can be adjusted through the CT capacitor on the TPS3890. With this approach, the  $\overline{\text{RESET}}$  delay can be adjusted from a minimum of 25  $\mu\text{s}$  to a maximum of 30 seconds. For this design, a minimum delay of 7 seconds is needed until the watchdog timer is enabled. The CT capacitor calculation (see the TPS3890 data sheet) yields an ideal capacitance of 6.59  $\mu\text{F}$ , giving a closest standard ceramic capacitor value of 6.8  $\mu\text{F}$ . When connecting a 6.8- $\mu\text{F}$  capacitor from CT to GND, the typical delay time is 7.21 seconds. Figure 22 illustrates the typical startup waveform for this circuit when the watchdog input is off. Figure 22 illustrates that when the watchdog is disabled, the  $\overline{\text{WDO}}$  output remains high. See the TPS3890 data sheet for detailed information on the TPS3890.

### 8.2.3 Glitch Immunity

Figure 25 shows the high to low glitch immunity for the TPS3852G33 with a 7% overdrive with  $V_{DD}$  starting at 3.3 V. This curve shows that  $V_{DD}$  can go below the threshold for 5.2  $\mu$ s without RESET asserting.

### 8.2.4 Application Curves

Unless otherwise stated, application curves were taken at  $T_A = 25^\circ\text{C}$ .

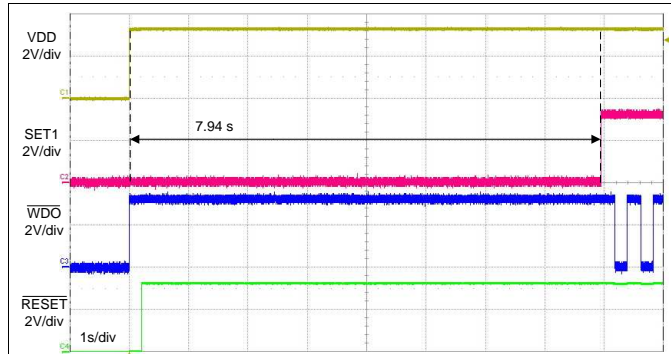

Figure 22. Startup Without a WDI Signal

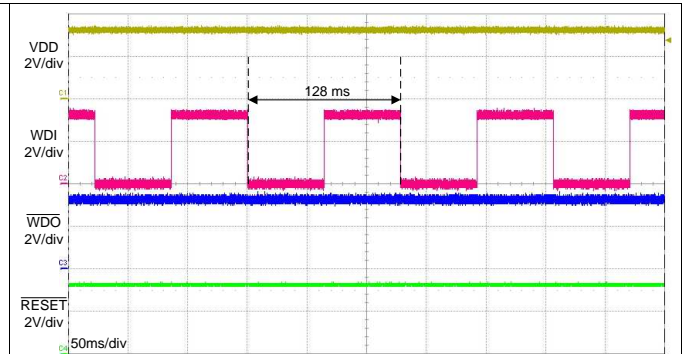

Figure 23. Typical WDI Signal

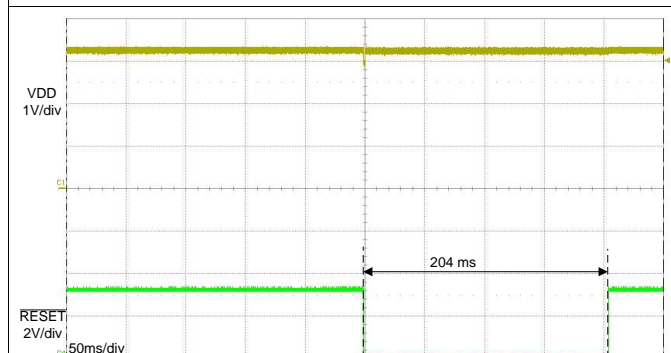

Figure 24. Typical  $\overline{\text{RESET}}$  Delay

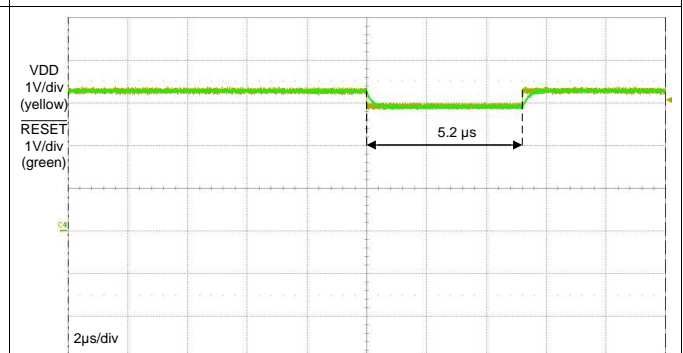

Figure 25. High to Low Glitch Immunity

## 9 Power Supply Recommendations

These devices are designed to operate from an input supply with a voltage range between 1.6 V and 6.5 V. An input supply capacitor is not required for this device; however, if the input supply is noisy, then good analog practice is to place a 0.1- $\mu$ F capacitor between the VDD pin and the GND pin.

## 10 Layout

### 10.1 Layout Guidelines

- Make sure that the connection to the VDD pin is low impedance. Good analog design practice is to place a 0.1- $\mu$ F ceramic capacitor as near as possible to the VDD pin.
- If a  $C_{CWD}$  capacitor or pull-up resistor is used place them as close as possible to the CWD pin. If the CWD pin is left unconnected make sure to minimize the amount of parasitic capacitance on the pin.
- The pull-up resistors on  $\overline{\text{RESET}}$  and  $\overline{\text{WDO}}$  should be placed as close to the pin as possible.

### 10.2 Layout Example

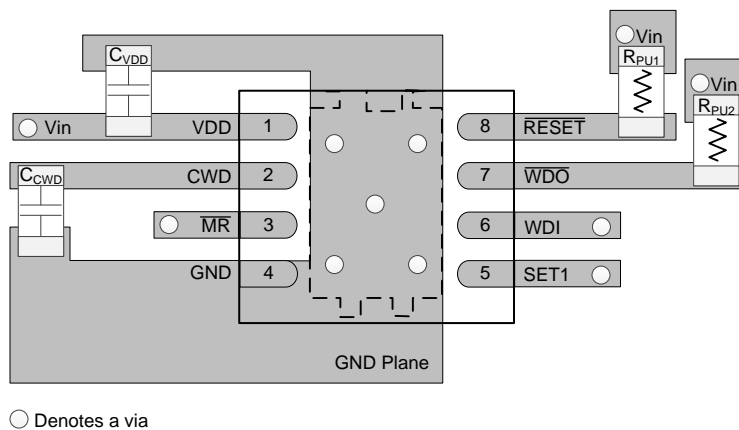

**Figure 26. Typical Layout For TPS3852**

## 11 Device and Documentation Support

### 11.1 Device Support

#### 11.1.1 Development Support

##### 11.1.1.1 Evaluation Module

The [TPS3851EVM-780 Evaluation Module](#) can be used to evaluate this part. If this evaluation module is being used then the part on the EVM must be changed to the TPS3852.

#### 11.1.2 Device Nomenclature

**Table 5. Device Nomenclature**

DESCRIPTION	NOMENCLATURE	VALUE
TPS3852 (high-accuracy supervisor with window watchdog)	—	—
X (nominal threshold as a percent of the nominal monitored voltage)	G	$V_{ITN} = -4\%$
	H	$V_{ITN} = -7\%$
yy(y) <sup>(1)</sup> (nominal monitored voltage option)	33	3.3 V

(1) For example TPS3852G33 corresponds to a 3.3 V nominal monitored voltage with a -4% nominal threshold.

### 11.2 Documentation Support

#### 11.2.1 Related Documentation

For related documentation see the following:

- [TPS3890 Low Quiescent Current, 1% Accurate Supervisor with Programmable Delay](#) (SLVSD65)
- [TPS3851EVM-780 Evaluation Module](#) (SBVU033)

#### 11.3 Receiving Notification of Documentation Updates

To receive notification of documentation updates, navigate to the device product folder on ti.com. In the upper right corner, click on *Alert me* to register and receive a weekly digest of any product information that has changed. For change details, review the revision history included in any revised document.

#### 11.4 Community Resources

The following links connect to TI community resources. Linked contents are provided "AS IS" by the respective contributors. They do not constitute TI specifications and do not necessarily reflect TI's views; see TI's [Terms of Use](#).

**TI E2E™ Online Community** *TI's Engineer-to-Engineer (E2E) Community*. Created to foster collaboration among engineers. At e2e.ti.com, you can ask questions, share knowledge, explore ideas and help solve problems with fellow engineers.

**Design Support** *TI's Design Support* Quickly find helpful E2E forums along with design support tools and contact information for technical support.

#### 11.5 Trademarks

E2E is a trademark of Texas Instruments.  
All other trademarks are the property of their respective owners.

#### 11.6 Electrostatic Discharge Caution



This integrated circuit can be damaged by ESD. Texas Instruments recommends that all integrated circuits be handled with appropriate precautions. Failure to observe proper handling and installation procedures can cause damage.

ESD damage can range from subtle performance degradation to complete device failure. Precision integrated circuits may be more susceptible to damage because very small parametric changes could cause the device not to meet its published specifications.

## 11.7 Glossary

[SLYZ022](#) — *TI Glossary*.

This glossary lists and explains terms, acronyms, and definitions.

## 12 Mechanical, Packaging, and Orderable Information

The following pages include mechanical, packaging, and orderable information. This information is the most current data available for the designated devices. This data is subject to change without notice and revision of this document. For browser-based versions of this data sheet, refer to the left-hand navigation.

**PACKAGING INFORMATION**

Orderable Device	Status (1)	Package Type	Package Drawing	Pins	Package Qty	Eco Plan (2)	Lead finish/ Ball material (6)	MSL Peak Temp (3)	Op Temp (°C)	Device Marking (4/5)	Samples
TPS3852G33DRBR	ACTIVE	SON	DRB	8	3000	RoHS & Green	NIPDAU	Level-1-260C-UNLIM	-40 to 125	852GA	<a href="#">Samples</a>
TPS3852G33DRBT	ACTIVE	SON	DRB	8	250	RoHS & Green	NIPDAU	Level-1-260C-UNLIM	-40 to 125	852GA	<a href="#">Samples</a>
TPS3852H33DRBR	ACTIVE	SON	DRB	8	3000	RoHS & Green	NIPDAU	Level-1-260C-UNLIM	-40 to 125	852PA	<a href="#">Samples</a>
TPS3852H33DRBT	ACTIVE	SON	DRB	8	250	RoHS & Green	NIPDAU	Level-1-260C-UNLIM	-40 to 125	852PA	<a href="#">Samples</a>

(1) The marketing status values are defined as follows:

**ACTIVE:** Product device recommended for new designs.

**LIFEBUY:** TI has announced that the device will be discontinued, and a lifetime-buy period is in effect.

**NRND:** Not recommended for new designs. Device is in production to support existing customers, but TI does not recommend using this part in a new design.

**PREVIEW:** Device has been announced but is not in production. Samples may or may not be available.

**OBSELETE:** TI has discontinued the production of the device.

(2) **RoHS:** TI defines "RoHS" to mean semiconductor products that are compliant with the current EU RoHS requirements for all 10 RoHS substances, including the requirement that RoHS substance do not exceed 0.1% by weight in homogeneous materials. Where designed to be soldered at high temperatures, "RoHS" products are suitable for use in specified lead-free processes. TI may reference these types of products as "Pb-Free".

**RoHS Exempt:** TI defines "RoHS Exempt" to mean products that contain lead but are compliant with EU RoHS pursuant to a specific EU RoHS exemption.

**Green:** TI defines "Green" to mean the content of Chlorine (Cl) and Bromine (Br) based flame retardants meet JS709B low halogen requirements of <=1000ppm threshold. Antimony trioxide based flame retardants must also meet the <=1000ppm threshold requirement.

(3) MSL, Peak Temp. - The Moisture Sensitivity Level rating according to the JEDEC industry standard classifications, and peak solder temperature.

(4) There may be additional marking, which relates to the logo, the lot trace code information, or the environmental category on the device.

(5) Multiple Device Markings will be inside parentheses. Only one Device Marking contained in parentheses and separated by a "-" will appear on a device. If a line is indented then it is a continuation of the previous line and the two combined represent the entire Device Marking for that device.

(6) Lead finish/Ball material - Orderable Devices may have multiple material finish options. Finish options are separated by a vertical ruled line. Lead finish/Ball material values may wrap to two lines if the finish value exceeds the maximum column width.

**Important Information and Disclaimer:**The information provided on this page represents TI's knowledge and belief as of the date that it is provided. TI bases its knowledge and belief on information provided by third parties, and makes no representation or warranty as to the accuracy of such information. Efforts are underway to better integrate information from third parties. TI has taken and

continues to take reasonable steps to provide representative and accurate information but may not have conducted destructive testing or chemical analysis on incoming materials and chemicals. TI and TI suppliers consider certain information to be proprietary, and thus CAS numbers and other limited information may not be available for release.

In no event shall TI's liability arising out of such information exceed the total purchase price of the TI part(s) at issue in this document sold by TI to Customer on an annual basis.

**OTHER QUALIFIED VERSIONS OF TPS3852 :**

- Automotive : [TPS3852-Q1](#)

NOTE: Qualified Version Definitions:

- Automotive - Q100 devices qualified for high-reliability automotive applications targeting zero defects

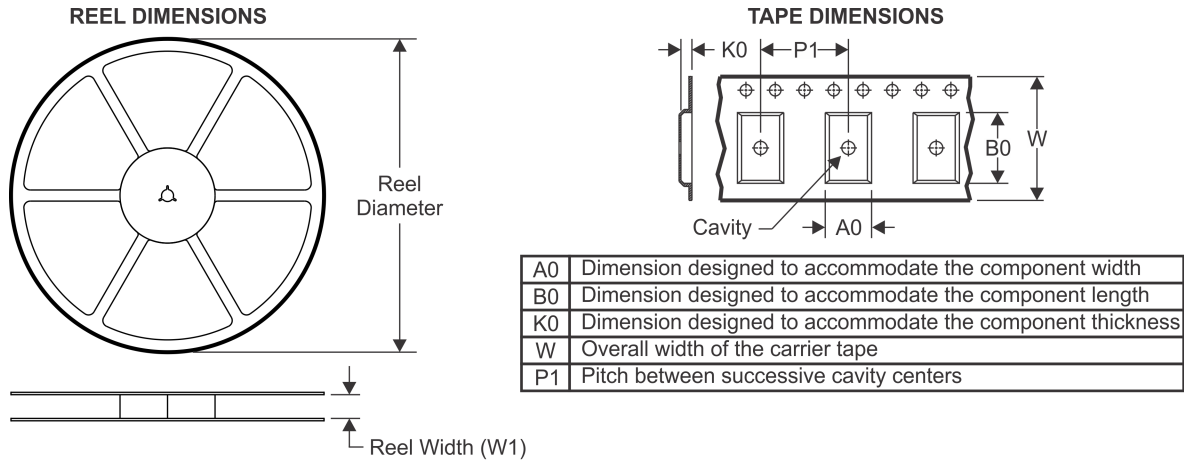
**TAPE AND REEL INFORMATION**

**QUADRANT ASSIGNMENTS FOR PIN 1 ORIENTATION IN TAPE**

\*All dimensions are nominal

Device	Package Type	Package Drawing	Pins	SPQ	Reel Diameter (mm)	Reel Width W1 (mm)	A0 (mm)	B0 (mm)	K0 (mm)	P1 (mm)	W (mm)	Pin1 Quadrant
TPS3852G33DRBR	SON	DRB	8	3000	330.0	12.4	3.3	3.3	1.1	8.0	12.0	Q2
TPS3852G33DRBT	SON	DRB	8	250	180.0	12.4	3.3	3.3	1.1	8.0	12.0	Q2
TPS3852H33DRBR	SON	DRB	8	3000	330.0	12.4	3.3	3.3	1.1	8.0	12.0	Q2
TPS3852H33DRBT	SON	DRB	8	250	180.0	12.4	3.3	3.3	1.1	8.0	12.0	Q2

**TAPE AND REEL BOX DIMENSIONS**

\*All dimensions are nominal

Device	Package Type	Package Drawing	Pins	SPQ	Length (mm)	Width (mm)	Height (mm)
TPS3852G33DRBR	SON	DRB	8	3000	367.0	367.0	35.0
TPS3852G33DRBT	SON	DRB	8	250	210.0	185.0	35.0
TPS3852H33DRBR	SON	DRB	8	3000	367.0	367.0	35.0
TPS3852H33DRBT	SON	DRB	8	250	210.0	185.0	35.0

**DRB 8**

**GENERIC PACKAGE VIEW**

**VSON - 1 mm max height**

PLASTIC SMALL OUTLINE - NO LEAD



Images above are just a representation of the package family, actual package may vary.  
Refer to the product data sheet for package details.

4203482/L

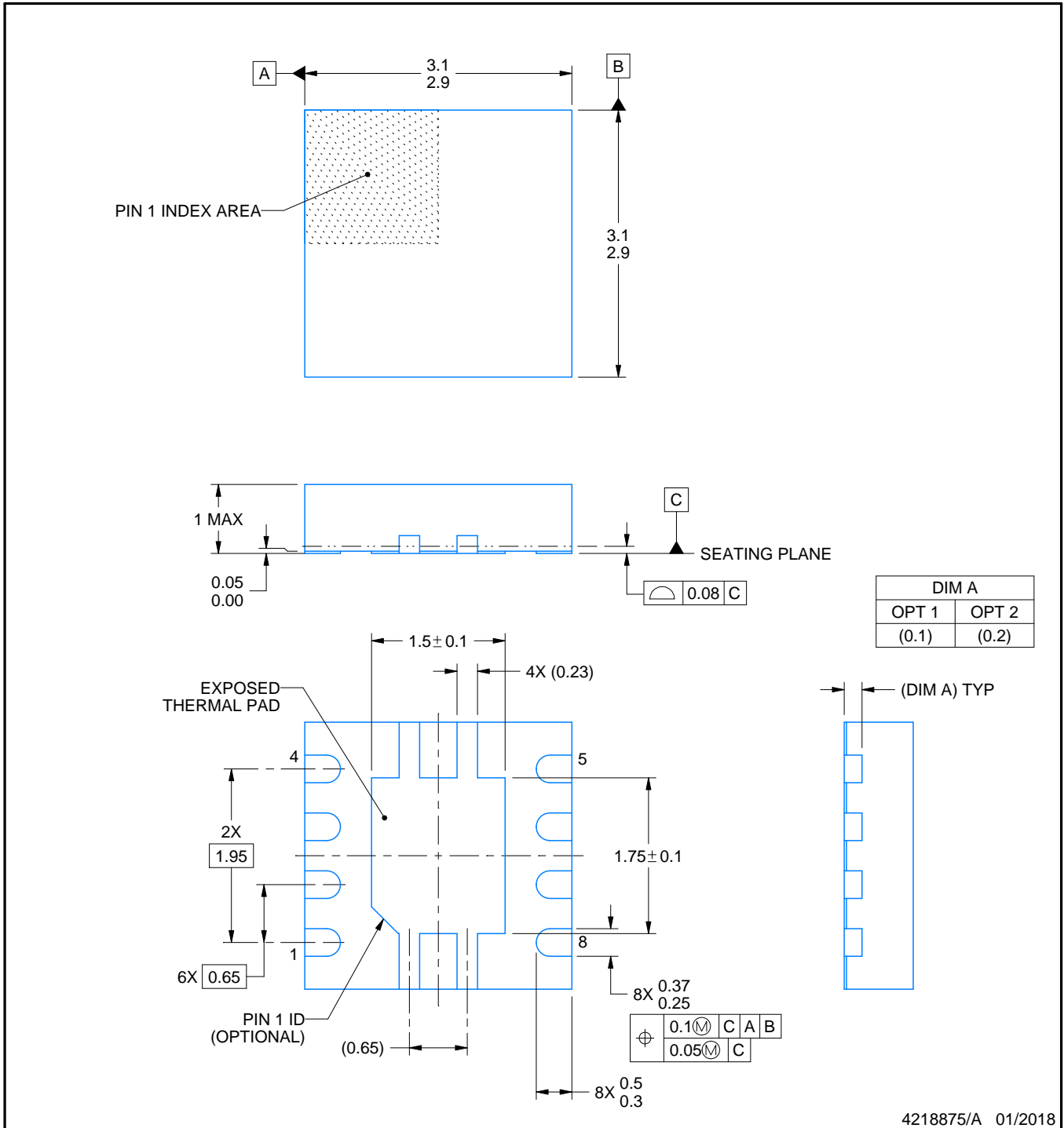

4218875/A 01/2018

NOTES:

1. All linear dimensions are in millimeters. Any dimensions in parenthesis are for reference only. Dimensioning and tolerancing per ASME Y14.5M.
2. This drawing is subject to change without notice.
3. The package thermal pad must be soldered to the printed circuit board for thermal and mechanical performance.

# EXAMPLE BOARD LAYOUT

DRB0008A

VSON - 1 mm max height

PLASTIC SMALL OUTLINE - NO LEAD

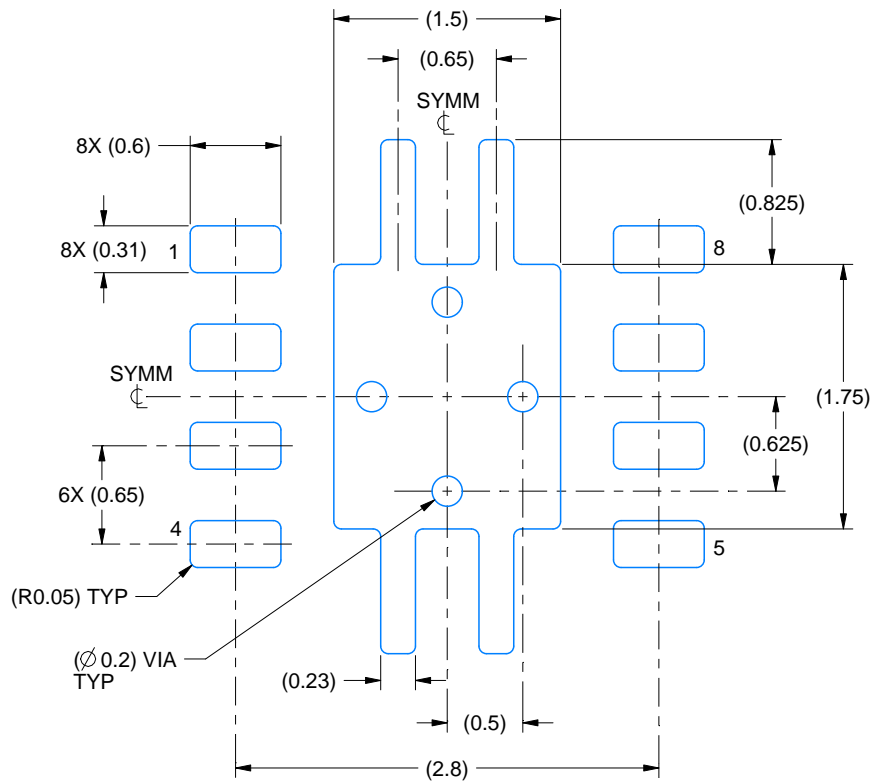

LAND PATTERN EXAMPLE  
EXPOSED METAL SHOWN  
SCALE:20X

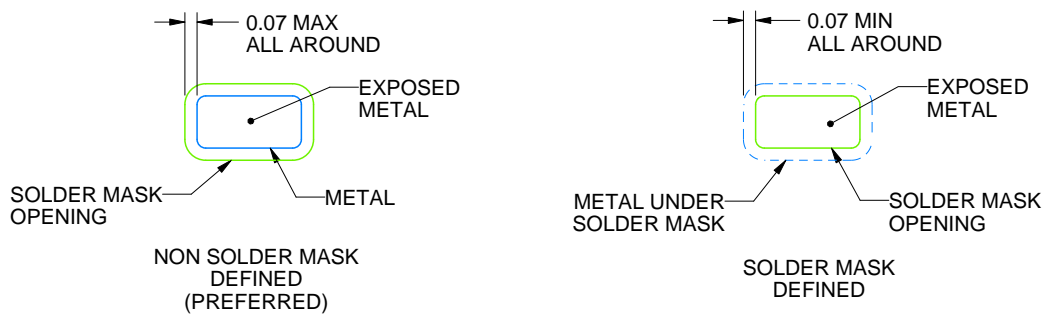

SOLDER MASK DETAILS

4218875/A 01/2018

NOTES: (continued)

4. This package is designed to be soldered to a thermal pad on the board. For more information, see Texas Instruments literature number SLUA271 ([www.ti.com/lit/sluea271](http://www.ti.com/lit/sluea271)).
5. Vias are optional depending on application, refer to device data sheet. If any vias are implemented, refer to their locations shown on this view. It is recommended that vias under paste be filled, plugged or tented.

# EXAMPLE STENCIL DESIGN

DRB0008A

VSON - 1 mm max height

PLASTIC SMALL OUTLINE - NO LEAD



SOLDER PASTE EXAMPLE  
BASED ON 0.125 mm THICK STENCIL

EXPOSED PAD  
84% PRINTED SOLDER COVERAGE BY AREA  
SCALE:25X

4218875/A 01/2018

NOTES: (continued)

6. Laser cutting apertures with trapezoidal walls and rounded corners may offer better paste release. IPC-7525 may have alternate design recommendations.

## IMPORTANT NOTICE AND DISCLAIMER

TI PROVIDES TECHNICAL AND RELIABILITY DATA (INCLUDING DATASHEETS), DESIGN RESOURCES (INCLUDING REFERENCE DESIGNS), APPLICATION OR OTHER DESIGN ADVICE, WEB TOOLS, SAFETY INFORMATION, AND OTHER RESOURCES "AS IS" AND WITH ALL FAULTS, AND DISCLAIMS ALL WARRANTIES, EXPRESS AND IMPLIED, INCLUDING WITHOUT LIMITATION ANY IMPLIED WARRANTIES OF MERCHANTABILITY, FITNESS FOR A PARTICULAR PURPOSE OR NON-INFRINGEMENT OF THIRD PARTY INTELLECTUAL PROPERTY RIGHTS.

These resources are intended for skilled developers designing with TI products. You are solely responsible for (1) selecting the appropriate TI products for your application, (2) designing, validating and testing your application, and (3) ensuring your application meets applicable standards, and any other safety, security, or other requirements. These resources are subject to change without notice. TI grants you permission to use these resources only for development of an application that uses the TI products described in the resource. Other reproduction and display of these resources is prohibited. No license is granted to any other TI intellectual property right or to any third party intellectual property right. TI disclaims responsibility for, and you will fully indemnify TI and its representatives against, any claims, damages, costs, losses, and liabilities arising out of your use of these resources.

TI's products are provided subject to TI's Terms of Sale (<https://www.ti.com/legal/termsofsale.html>) or other applicable terms available either on [ti.com](https://www.ti.com) or provided in conjunction with such TI products. TI's provision of these resources does not expand or otherwise alter TI's applicable warranties or warranty disclaimers for TI products.

Mailing Address: Texas Instruments, Post Office Box 655303, Dallas, Texas 75265  
Copyright © 2021, Texas Instruments Incorporated

## Looking for pricing, stock, or lifecycle information?

Click below to explore more details on WIN SOURCE:

 [View TPS3852G33DRBT](#) on WIN SOURCE

 [Texas Instruments](#) Information

## Optimize Your Supply Chain with WIN SOURCE Solutions

-  Global Sourcing Solution
-  Obsolete Management
-  Cost Control Management
-  Shortage Management
-  Alternative Solution
-  Excess Inventory Management