

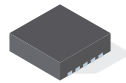

**THE DATASHEET OF
TPS40210SHKK**





5.5-V TO 52-V INPUT, CURRENT-MODE BOOST CONTROLLER

Check for Samples: [TPS40210-HT](#)

FEATURES

- For Boost, Flyback, SEPIC, LED Driver Applications
- Wide Input Operating Voltage: 5.5 V to 52 V
- Adjustable Oscillator Frequency
- Fixed-Frequency Current-Mode Control
- Internal Slope Compensation
- Integrated Low-Side Driver
- Programmable Closed-Loop Soft Start
- Overcurrent Protection
- External Synchronization Capable
- Reference Voltage: 700 mV
- Low-Current Disable Function

APPLICATIONS

- Down-Hole Drilling
- High Temperature Environments

SUPPORTS EXTREME TEMPERATURE APPLICATIONS

- Controlled Baseline
- One Assembly/Test Site
- One Fabrication Site
- Available in Extreme (–55°C/210°C) Temperature Range⁽¹⁾
- Extended Product Life Cycle
- Extended Product-Change Notification
- Product Traceability
- Texas Instruments high temperature products utilize highly optimized silicon (die) solutions with design and process enhancements to maximize performance over extended temperatures.

(1) Custom temperature ranges available

CONTENTS

Device Ratings	2
Electrical Characteristics	3
Typical Characteristics	5
Terminal Information	10
Application Information	12
Additional References	25
Design Examples	26

DESCRIPTION

The TPS40210 is a wide input voltage (5.5 V to 52 V) non-synchronous boost controller. It is suitable for topologies that require a grounded source N-channel FET, including boost, flyback, SEPIC, and various LED driver applications. Device features include programmable soft start, overcurrent protection with automatic retry, and programmable oscillator frequency. Current-mode control provides improved transient response and simplified loop compensation.

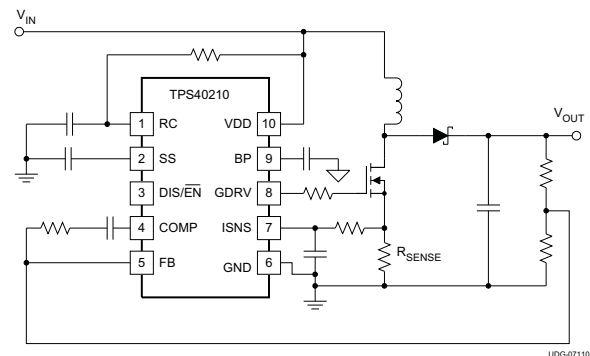

UDG-07110



Please be aware that an important notice concerning availability, standard warranty, and use in critical applications of Texas Instruments semiconductor products and disclaimers thereto appears at the end of this data sheet.



This integrated circuit can be damaged by ESD. Texas Instruments recommends that all integrated circuits be handled with appropriate precautions. Failure to observe proper handling and installation procedures can cause damage.

ESD damage can range from subtle performance degradation to complete device failure. Precision integrated circuits may be more susceptible to damage because very small parametric changes could cause the device not to meet its published specifications.

BARE DIE INFORMATION

DIE THICKNESS	BACKSIDE FINISH	BACKSIDE POTENTIAL	BOND PAD METALLIZATION COMPOSITION	BOND PAD THICKNESS
15 mils.	Silicon with backgrind	GND	Al-Cu (0.5%)	0.6 μm

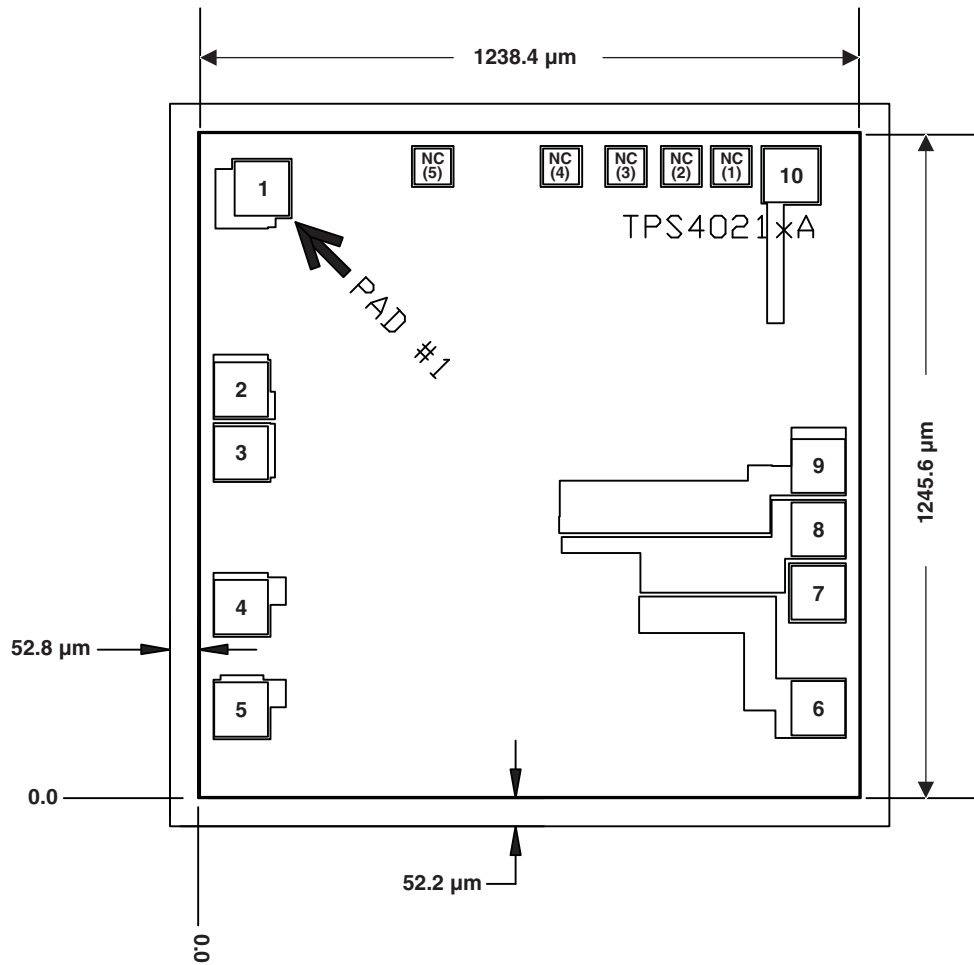

Table 1. Bond Pad Coordinates in Microns

DISCRIPTION	PAD NUMBER	X min	Y min	X max	Y max
RC	1	67.95	1089.45	168.75	1190.25
SS	2	28.8	714.15	129.6	814.95
DIS/EN	3	28.8	595.35	129.6	696.15
COMP	4	28.8	306.45	129.6	407.25
FB	5	28.8	115.29	129.6	216.09
GND	6	1108.62	117.45	1209.42	218.25
ISNS	7	1108.62	332.91	1209.42	433.71
GDRV	8	1108.62	451.71	1209.42	552.51
BP	9	1108.62	570.51	1209.42	671.31
VDD	10	1057.68	1114.02	1158.48	1214.82

Table 1. Bond Pad Coordinates in Microns (continued)

DISCRIPTION	PAD NUMBER	X min	Y min	X max	Y max
NC (1)		962.55	1147.32	1030.05	1214.82
NC (2)		868.59	1147.32	936.09	1214.82
NC (3)		764.73	1147.32	832.23	1214.82
NC (4)		643.68	1147.32	711.18	1214.82
NC (5)		403.74	1147.23	471.24	1214.73

ORDERING INFORMATION⁽¹⁾

T _A	PACKAGE ⁽²⁾	ORDERABLE PART NUMBER	TOP-SIDE MARKING
-55°C to 210°C	KGD (bare die)	TPS40210SKGD1	NA
	HKK	TPS40210SHKK	TPS40210SHKK

- (1) For the most current package and ordering information, see the Package Option Addendum at the end of this document, or see the TI web site at www.ti.com.
- (2) Package drawings, thermal data, and symbolization are available at www.ti.com/packaging.

DEVICE RATINGS
ABSOLUTE MAXIMUM RATINGS

 over operating free-air temperature range unless otherwise noted⁽¹⁾

Input voltage range	VDD	-0.3 V to 52 V
	RC, SS, FB, DIS/ $\overline{\text{EN}}$	-0.3 V to 10 V
	ISNS	-0.3 V to 8 V
Output voltage range	COMP, BP, GDRV	-0.3 V to 9 V
T _J Operating junction temperature range		-55°C to 210°C
T _{stg} Storage temperature range		-55°C to 210°C

- (1) Stresses beyond those listed under "absolute maximum ratings" may cause permanent damage to the device. These are stress ratings only, and functional operation of the device at these or any other conditions beyond those indicated under "recommended operating conditions" is not implied. Exposure to absolute-maximum-rated conditions for extended periods may affect device reliability.

RECOMMENDED OPERATING CONDITIONS

	MIN	MAX	UNIT
V _{VDD} Input voltage	5.5	52	V
T _J Operating junction temperature	-55	210	°C

THERMAL CHARACTERISTICS FOR HKK PACKAGE

over operating free-air temperature range (unless otherwise noted)

PARAMETER	TEST CONDITIONS	MIN	TYP	MAX	UNIT
θ _{JC} Junction-to-case thermal resistance	to bottom of case			4.6	°C/W
	to top of case - as if formed dead bug			12.9	

ELECTROSTATIC DISCHARGE (ESD) PROTECTION

	TYP	UNIT
Human-Body Model (HBM)	1500	V
Charged-Device Model (CDM)	1500	

ELECTRICAL CHARACTERISTICS

T_J = -55°C to 210°C, V_{VDD} = 12 V_{dc}, all parameters at zero power dissipation (unless otherwise noted)

PARAMETER		TEST CONDITIONS	T _A = -55°C to 125°C			T _A = 210°C			UNIT
			MIN	TYP	MAX	MIN	TYP	MAX	
Voltage Reference									
V _{FB}	Feedback voltage range	COMP = FB, 5.5 ≤ V _{VDD} ≤ 52 V	686	700	720	686	702	725	mV
Input Supply									
V _{VDD}	Input voltage range		4.5		52	5.5		52	V
I _{VDD}	Operating current	5.5 ≤ V _{VDD} ≤ 52 V, no switching, V _{DIS} < 0.8		1.5	2.5		1.5	3	mA
		2.5 ≤ V _{DIS} ≤ 7 V		10	20		23	90	μA
		V _{VDD} < V _{UVLO(on)} , V _{DIS} < 0.8		430	530		460	700	μA
Undervoltage Lockout (UVLO)									
V _{UVLO(on)}	Turn on threshold voltage		4	4.25	4.50		4.60		V
V _{UVLO(hyst)}	UVLO hysteresis		140	195	240		195		mV
Oscillator									
f _{OSC}	Oscillator frequency range ⁽¹⁾		35		1000	35		1000	kHz
	Oscillator frequency	R _{RC} = 200 kΩ, C _{RC} = 470 pF	260	300	340	260	300	400	
	Frequency line regulation	5.5 ≤ V _{DD} ≤ 52 V	-20		7	-20		7	%
V _{SLP}	Slope compensation ramp		520	620	720	480	640	750	mV
PWM									
t _{ON(min)}	Minimum pulse width	V _{VDD} = 12 V ⁽¹⁾		275	400		500		ns
		V _{VDD} = 30 V		90	200		120		
t _{OFF(min)}	Minimum off time			170	200		100		ns
V _{VLY}	Valley voltage			1.2					V
Soft-Start									
V _{SS(ofst)}	Offset voltage from SS pin to error amplifier input			700			700		mV
R _{SS(chg)}	Soft-start charge resistance		320	450	600	305	375	600	kΩ
R _{SS(dchg)}	Soft-start discharge resistance		840	1200	1600	700	968	1600	kΩ
Error Amplifier									
GBWP	Unity gain bandwidth product ⁽¹⁾		1.5	3		1.5	3		MHz
A _{OL}	Open loop gain ⁽¹⁾		60	80					dB
I _{IB(FB)}	Input bias current (current out of FB pin)			111	300		65		nA
I _{COMP(src)}	Output source current	V _{FB} = 0.6 V, V _{COMP} = 1 V	100	265		100	280		μA
I _{COMP(snk)}	Output sink current	V _{FB} = 1.2 V, V _{COMP} = 1 V	1.2	2.3		0.9	1.3		mA
Overcurrent Protection									
V _{ISNS(oc)}	Overcurrent detection threshold (at ISNS pin)	5.5 ≤ V _{DD} < 52 V, -55°C ≤ T _J ≤ 210°C	120	150	180	120	150	180	mV
D _{OC}	Overcurrent duty cycle ⁽¹⁾				2			2	%

(1) Specified by design

ELECTRICAL CHARACTERISTICS (continued)

$T_J = -55^{\circ}\text{C}$ to 210°C , $V_{VDD} = 12 V_{dc}$, all parameters at zero power dissipation (unless otherwise noted)

PARAMETER	TEST CONDITIONS	$T_A = -55^{\circ}\text{C}$ to 125°C			$T_A = 210^{\circ}\text{C}$			UNIT			
		MIN	TYP	MAX	MIN	TYP	MAX				
$V_{SS(rst)}$	Overcurrent reset threshold voltage (at SS pin)	100	150	350	100	150	350	mV			
T_{BLNK}	Leading edge blanking	75						ns			
Current-Sense Amplifier											
A_{CS}	Current sense amplifier gain	4.2	5.6	7.2	4	4.8	7.2	V/V			
$I_{B(INS)}$	Input bias current	1			3			μA			
Driver											
$I_{GDRV(src)}$	Gate driver source current	$V_{GDRV} = 4 V, T_J = 25^{\circ}\text{C}$			280	335	180	280	mA		
$I_{GDRV(snk)}$	Gate driver sink current	$V_{GDRV} = 4 V, T_J = 25^{\circ}\text{C}$			300	330	230	290	mA		
Linear Regulator											
V_{BP}	Bypass voltage output	$0 \text{ mA} < I_{BP} < 15 \text{ mA}$			7	8	9	4.8	8.45	10	V
Disable/Enable											
$V_{DIS(en)}$	Turn-on voltage	0.7	1	1.3	0.7	1	1.3	V			
$V_{DIS(hys)}$	Hysteresis voltage	25	145	220	25	155	220	mV			
R_{DIS}	DIS pin pulldown resistance	0.7	1.1	1.5	0.5	0.9	1.5	$\text{M}\Omega$			

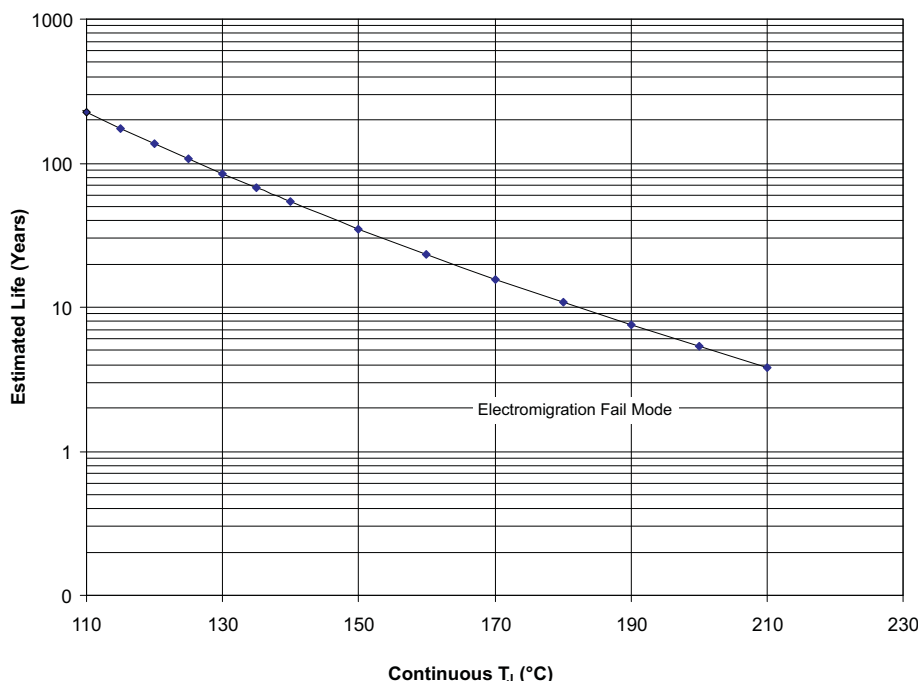

Notes:

1. See datasheet for absolute maximum and minimum recommended operating conditions.
2. Silicon operating life design goal is 10 years at 105°C junction temperature (does not include package interconnect life).

**Figure 1. TPS40210SKGD1/TPS40210SHKK
Operating Life Derating Chart**

TYPICAL CHARACTERISTICS

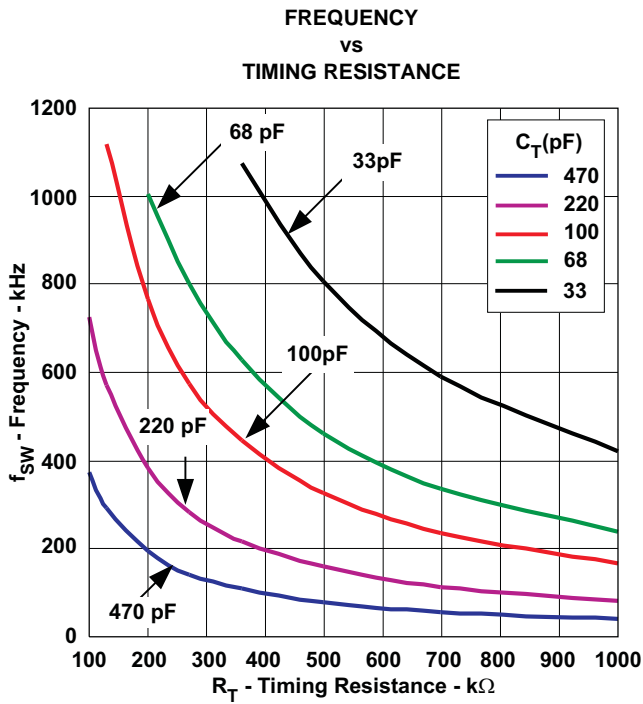

Figure 2.

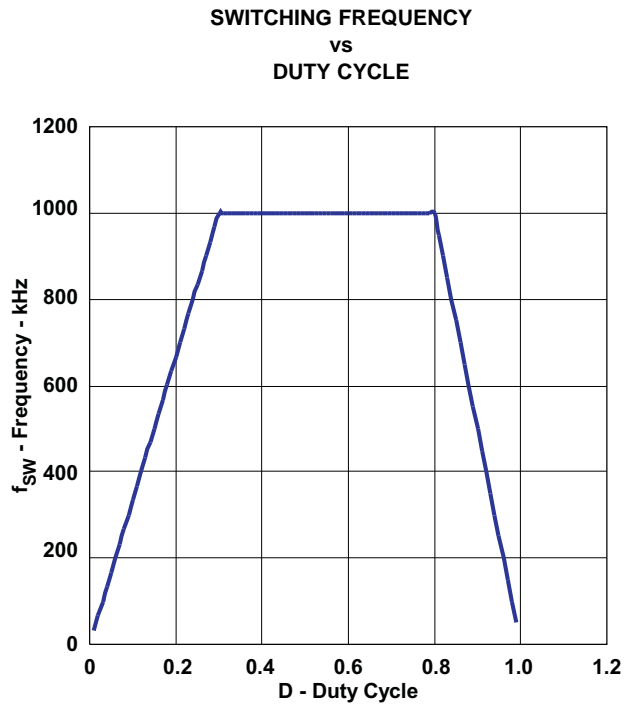

Figure 3.

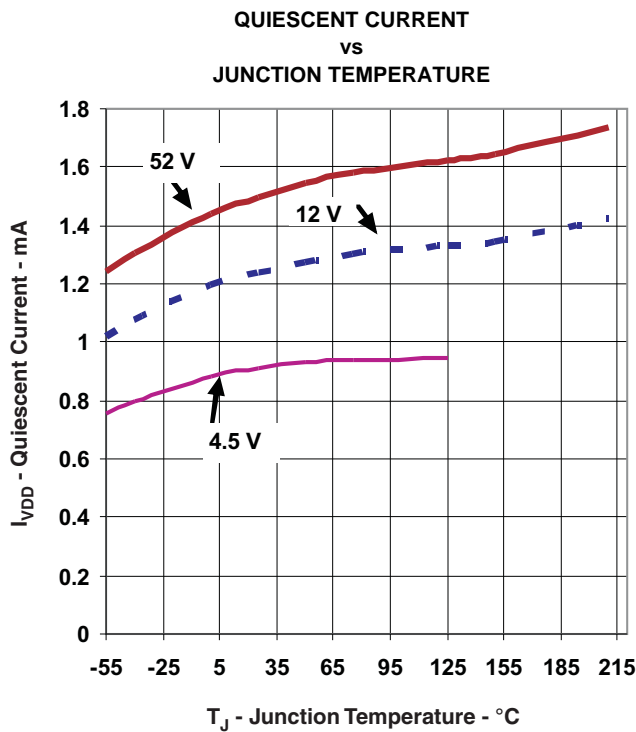

Figure 4.

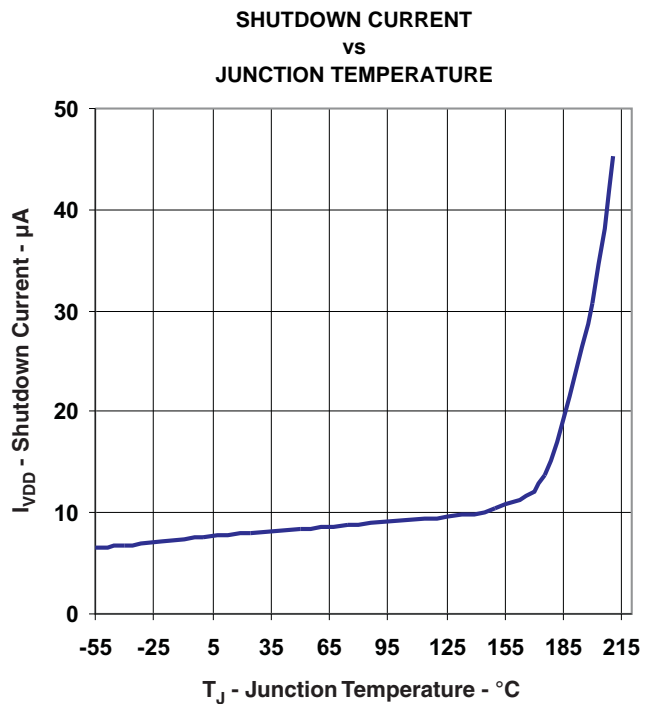

Figure 5.

TYPICAL CHARACTERISTICS (continued)

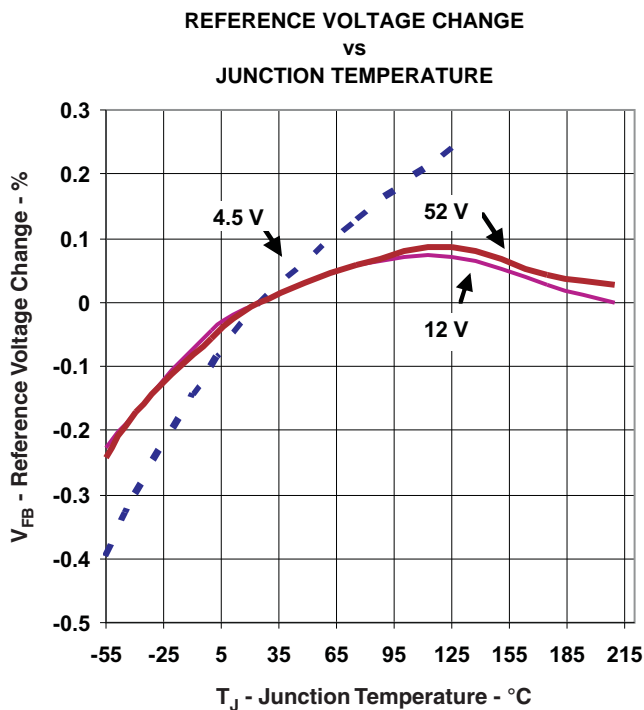

Figure 6.

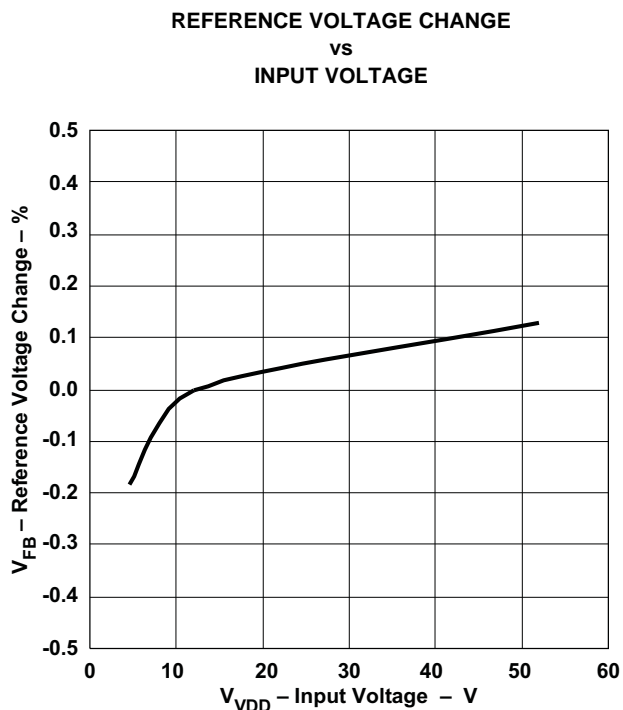

Figure 7.

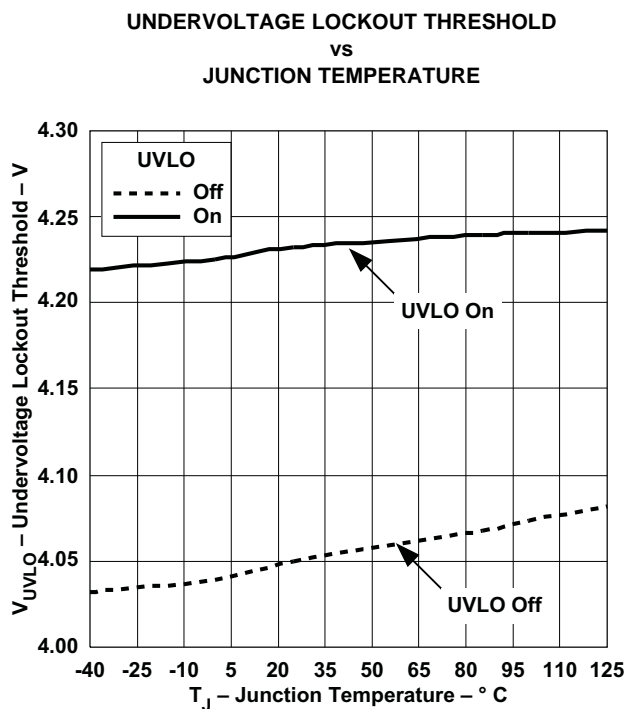

Figure 8.

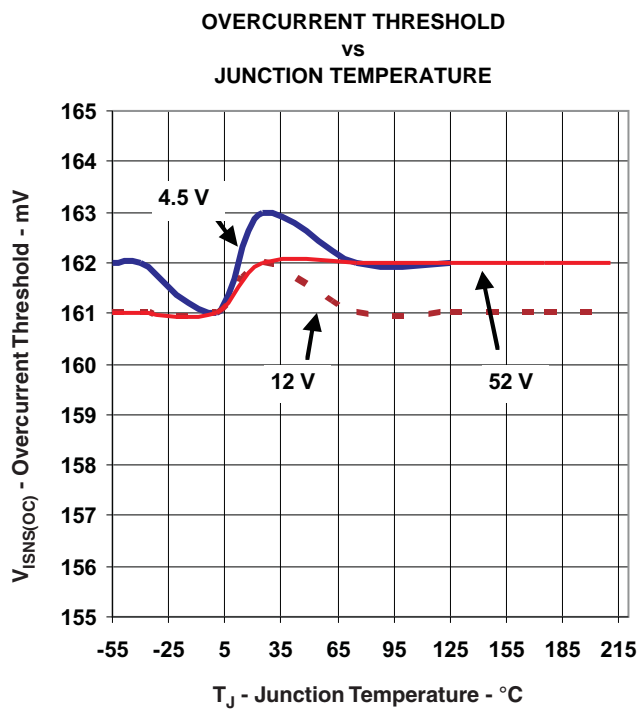

Figure 9.

TYPICAL CHARACTERISTICS (continued)

OVERCURRENT THRESHOLD
vs
INPUT VOLTAGE

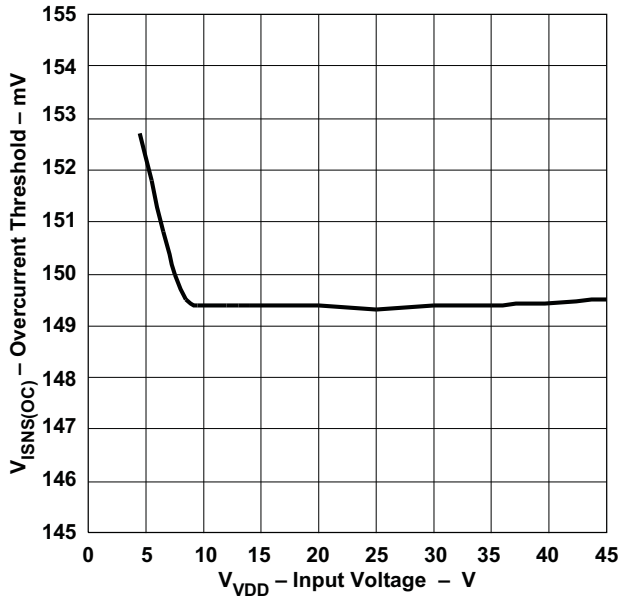

Figure 10.

SWITCHING FREQUENCY CHANGE
vs
JUNCTION TEMPERATURE

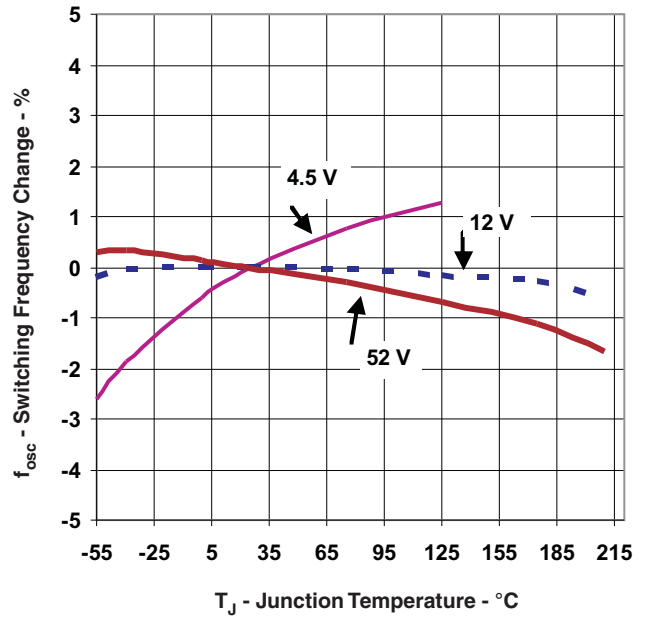

Figure 11.

OSCILLATOR AMPLITUDE
vs
JUNCTION TEMPERATURE

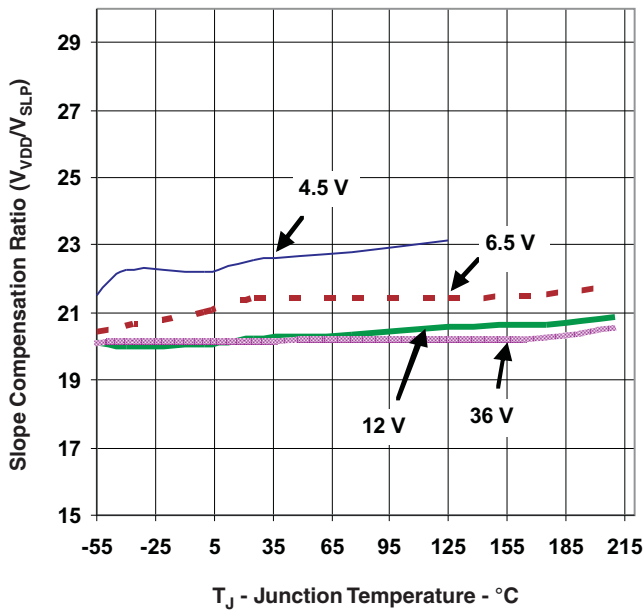

Figure 12.

SOFT-START CHARGE/DISCHARGE RESISTANCE
vs
JUNCTION TEMPERATURE

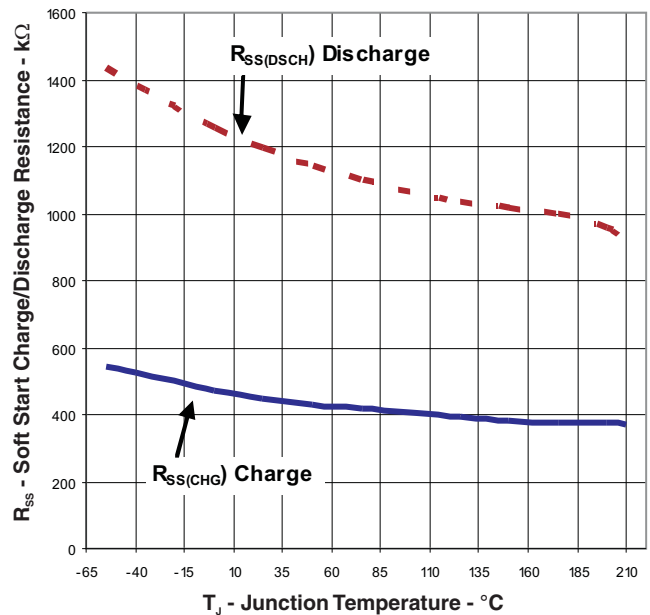

Figure 13.

TYPICAL CHARACTERISTICS (continued)

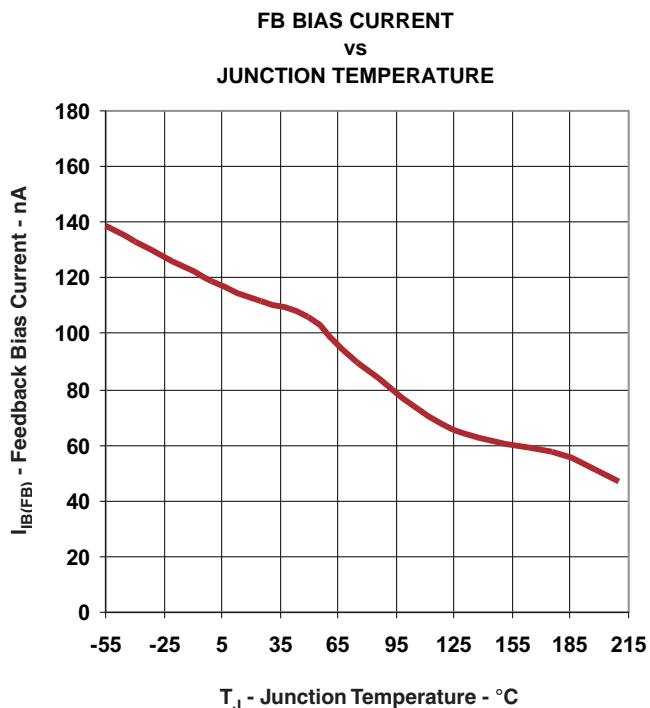

Figure 14.

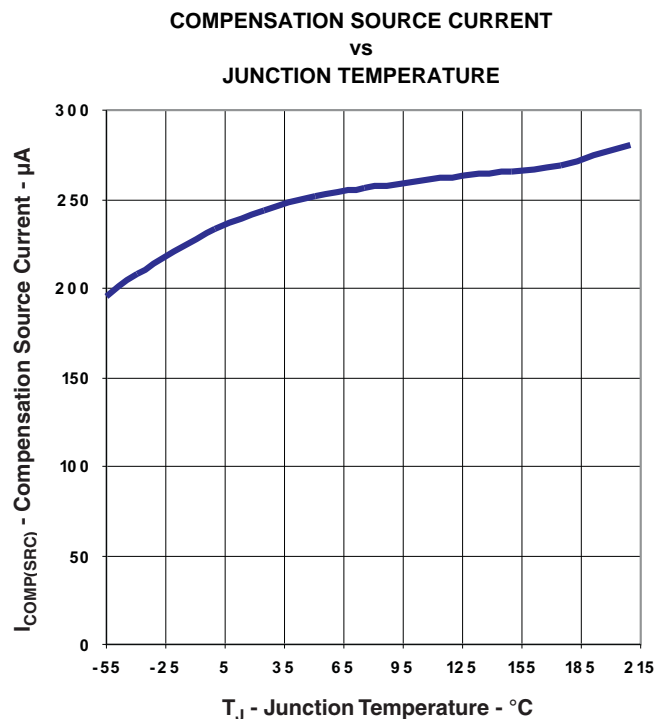

Figure 15.

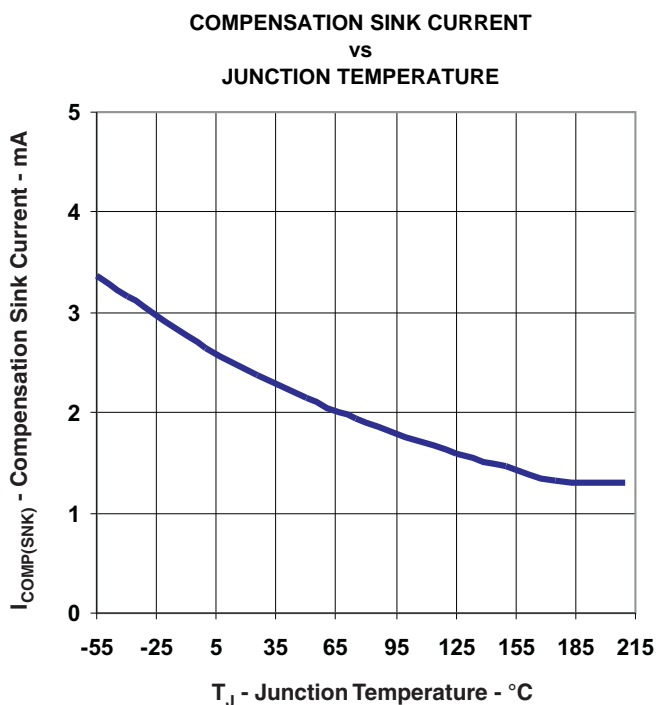

Figure 16.

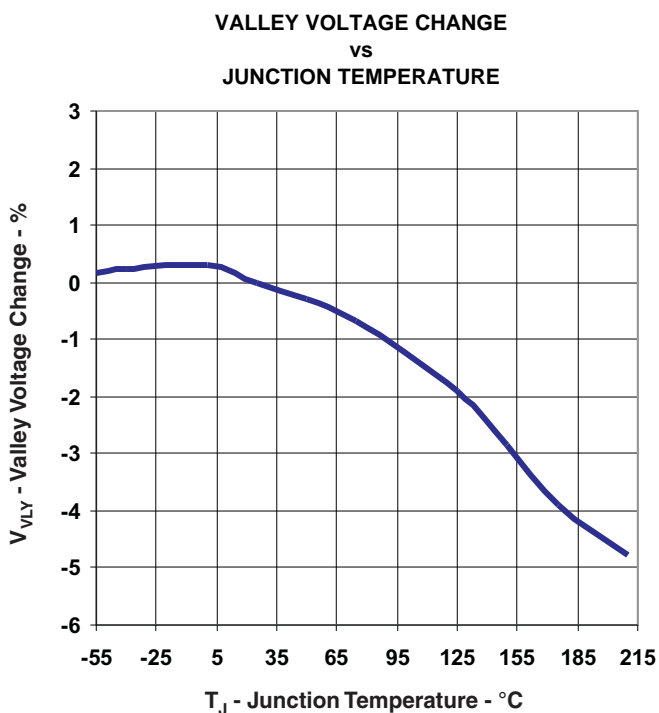

Figure 17.

TYPICAL CHARACTERISTICS (continued)

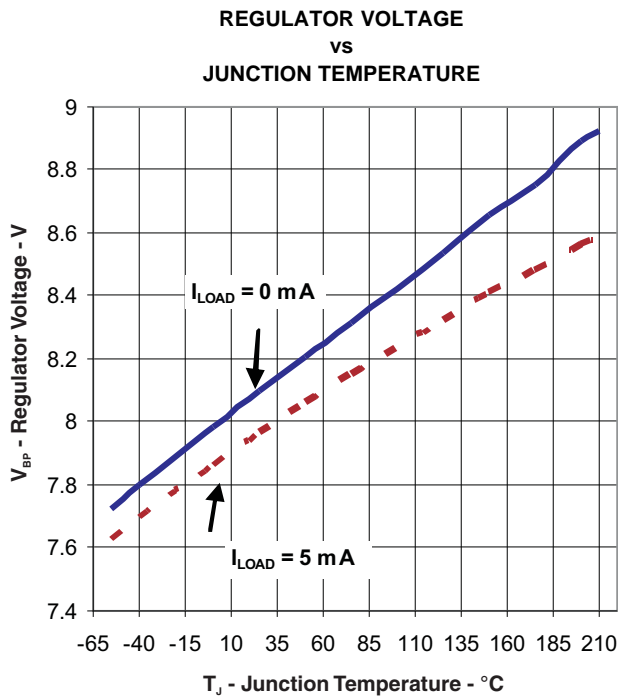

Figure 18.

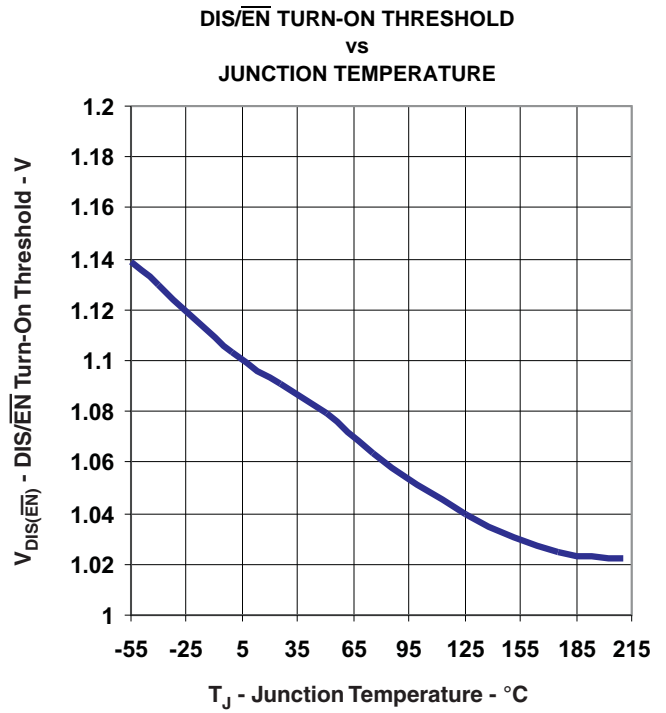

Figure 19.

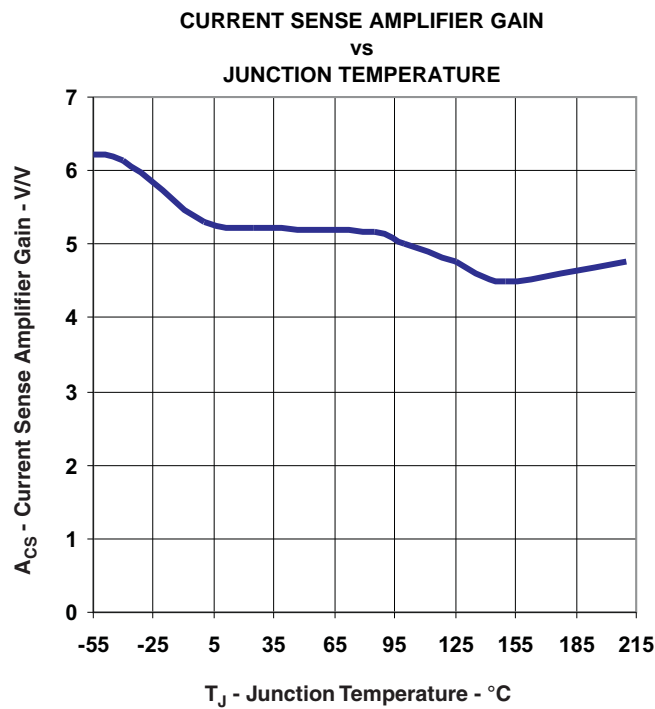
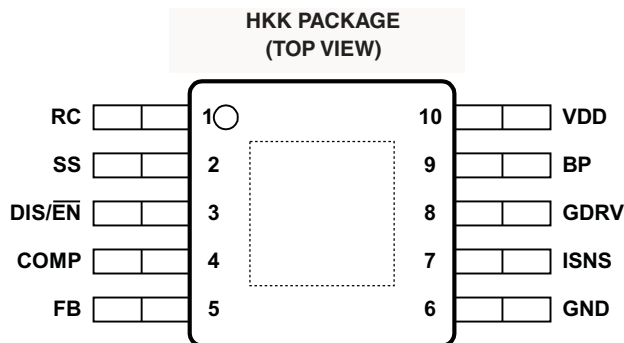

Figure 20.

DEVICE INFORMATION
TERMINAL FUNCTIONS

TERMINAL		I/O	DESCRIPTION
NAME	NO.		
BP	9	O	Regulator output. Connect a 1.0- μ F bypass capacitor from this pin to GND.
COMP	4	O	Error amplifier output. Connect control loop compensation network between COMP pin and FB pin.
DIS/ $\overline{\text{EN}}$	3	I	Disable/enable. Pulling this pin high places the part into a shutdown mode. Shutdown mode is characterized by a very low quiescent current. While in shutdown mode, the functionality of all blocks is disabled, and the BP regulator is shut down. This pin has an internal 1-M Ω pulldown resistor to GND. Leaving this pin unconnected enables the device.
FB	5	I	Error amplifier inverting input. Connect a voltage divider from the output to this pin to set the output voltage. Compensation network is connected between this pin and COMP.
GDRV	8	O	Connect the gate of the power N-channel MOSFET to this pin.
GND	6	–	Device ground
ISNS	7	I	Current sense. Connect an external current sensing resistor between this pin and GND. The voltage on this pin is used to provide current feedback in the control loop and detect an overcurrent condition. An overcurrent condition is declared when ISNS pin voltage exceeds the overcurrent threshold voltage, 150 mV typical.
RC	1	I	Switching frequency setting. Connect capacitor from RC pin to GND. Connect a resistor from RC pin to VDD of the IC power supply and a capacitor from RC to GND.
SS	2	I	Soft-start time programming. Connect capacitor from SS pin to GND to program converter soft-start time. This pin also functions as a timeout timer when the power supply is in an overcurrent condition.
VDD	10	I	System input voltage. Connect a local bypass capacitor from this pin to GND. Depending on the amount of required slope compensation, this pin can be connected to the converter output. See <i>Application Information</i> section for additional details.



FUNCTIONAL BLOCK DIAGRAM

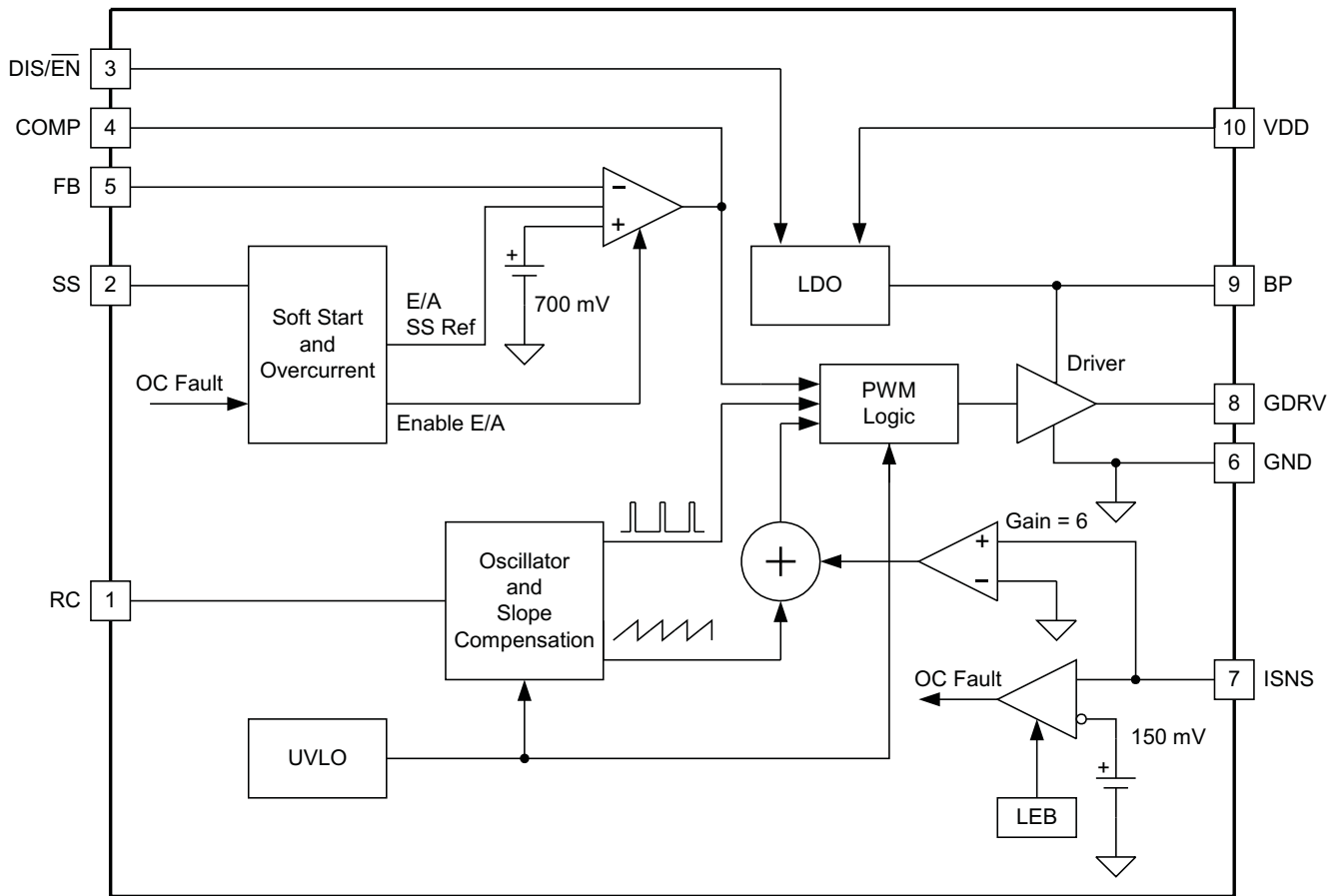

UDG-07107

APPLICATION INFORMATION

Minimum On-Time and Off-Time Considerations

The TPS40210 has a minimum off time of approximately 200 ns and a minimum on time of 300 ns. These two constraints place limitations on the operating frequency that can be used for a given input-to-output conversion ratio. See [Figure 3](#) for the maximum frequency that can be used for a given duty cycle.

The duty cycle at which the converter operates is dependent on the mode in which the converter is running. If the converter is running in discontinuous conduction mode, the duty cycle varies with changes to the load much more than it does when running in continuous conduction mode.

In continuous conduction mode, the duty cycle is related primarily to the input and output voltages.

$$\frac{V_{OUT} + V_D}{V_{IN}} = \frac{1}{1-D} \quad (1)$$

$$D = \left(1 - \left(\frac{V_{IN}}{V_{OUT} + V_D} \right) \right) \quad (2)$$

In discontinuous mode, the duty cycle is a function of the load, input and output voltages, inductance, and switching frequency.

$$D = \frac{2 \times (V_{OUT} + V_D) \times I_{OUT} \times L \times f_{SW}}{(V_{IN})^2} \quad (3)$$

All converters using a diode as the freewheeling or catch component have a load current level at which they transition from discontinuous conduction to continuous conduction. This is the point at which the inductor current falls to zero. At higher load currents, the inductor current does not fall to zero but remains flowing in a positive direction and assumes a trapezoidal wave shape as opposed to a triangular wave shape. This load boundary between discontinuous conduction and continuous conduction can be found for a set of converter parameters as shown in [Equation 4](#).

$$I_{OUT(crit)} = \frac{(V_{OUT} + V_D - V_{IN}) \times (V_{IN})^2}{2 \times (V_{OUT} + V_D)^2 \times f_{SW} \times L} \quad (4)$$

For loads higher than the result of [Equation 4](#), the duty cycle is given by [Equation 2](#), and for loads less than the results of [Equation 4](#), the duty cycle is given [Equation 3](#). For [Equation 1](#) through [Equation 4](#), the variable definitions are as follows:

- V_{OUT} is the output voltage of the converter in V
- V_D is the forward conduction voltage drop across the rectifier or catch diode in V
- V_{IN} is the input voltage to the converter in V
- I_{OUT} is the output current of the converter in A
- L is the inductor value in H
- f_{SW} is the switching frequency in Hz

Setting the Oscillator Frequency

The oscillator frequency is determined by a resistor and capacitor connected to the RC pin of the TPS40210. The capacitor is charged to a level of approximately $V_{VDD}/20$ by current flowing through the resistor and is then discharged by a transistor internal to the TPS40210. The required resistor for a given oscillator frequency is found from either [Figure 2](#) or [Equation 5](#).

$$R_T = \frac{1}{5.8 \times 10^{-8} \times f_{SW} \times C_T + 8 \times 10^{-10} \times f_{SW}^2 + 1.4 \times 10^{-7} \times f_{SW} - 1.5 \times 10^{-4} + 1.7 \times 10^{-6} \times C_T - 4 \times 10^{-9} \times C_T^2}$$

where

- R_T is the timing resistance in $k\Omega$
 - f_{SW} is the switching frequency in kHz
 - C_T is the timing capacitance in pF
- (5)

For most applications, a capacitor in the range of 68 pF to 120 pF gives the best results. Resistor values should be limited to between 100 $k\Omega$ and 1 $M\Omega$ as well. If the resistor value falls below 100 $k\Omega$, decrease the capacitor size and recalculate the resistor value for the desired frequency. As the capacitor size decreases below 47 pF, the accuracy of [Equation 5](#) degrades, and empirical means may be needed to fine tune the timing component values to achieve the desired switching frequency.

Synchronizing the Oscillator

The TPS40210 can be synchronized to an external clock source. [Figure 21](#) shows the functional diagram of the oscillator. When synchronizing the oscillator to an external clock, the RC pin must be pulled below 150 mV for 20 ns or more. The external clock frequency must be higher than the free running frequency of the converter as well. When synchronizing the controller, if the RC pin is held low for an excessive amount of time, erratic operation may occur. The maximum amount of time that the RC pin should be held low is 50% of a nominal output pulse, or 10% of the period of the synchronization frequency.

Under circumstances where the duty cycle is less than 50%, a Schottky diode connected from the RC pin to an external clock may be used to synchronize the oscillator. The cathode of the diode is connected to the RC pin. The trip point of the oscillator is set by an internal voltage divider to be 1/20 of the input voltage. The clock signal must have an amplitude higher than this trip point. When the clock goes low, it allows the reset current to restart the RC ramp, synchronizing the oscillator to the external clock. This provides a simple single-component method for clock synchronization.

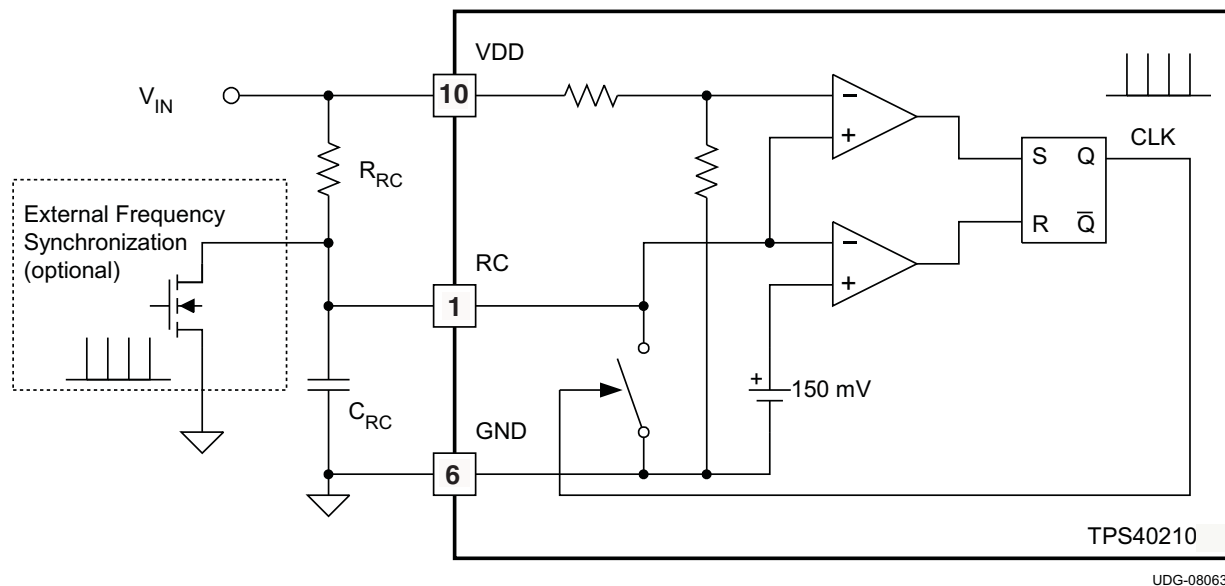

Figure 21. Oscillator Functional Diagram

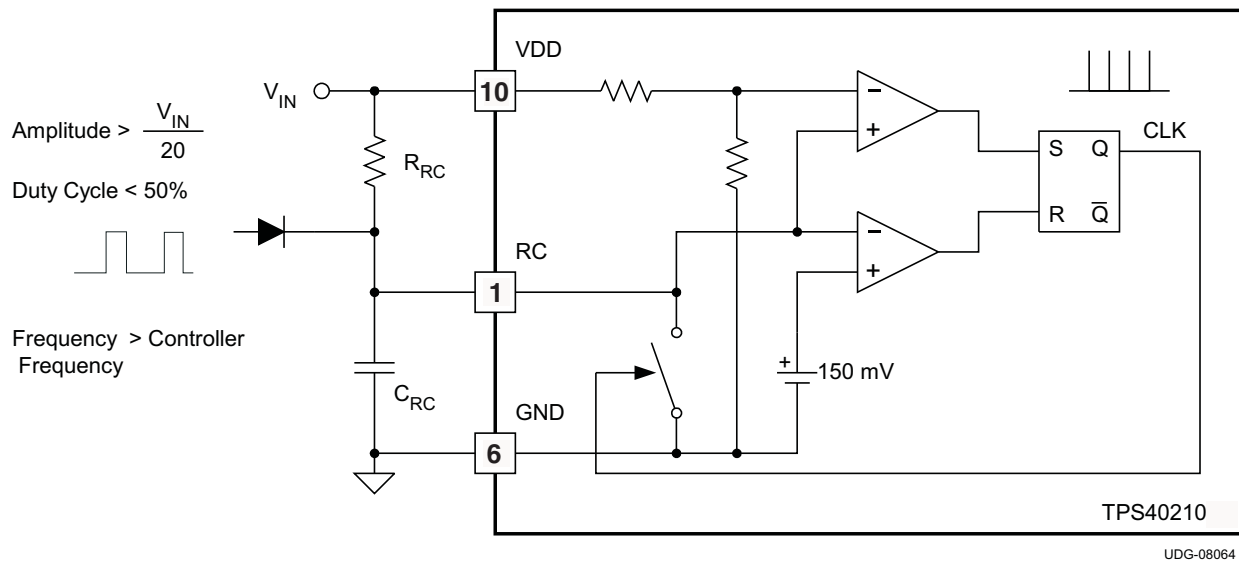

Figure 22. Diode Connected Synchronization

Current Sense and Overcurrent

The TPS40210 are current-mode controllers and use a resistor in series with the source terminal power FET to sense current for both the current-mode control and overcurrent protection. The device enters a current-limit state if the voltage on the ISNS pin exceeds the current-limit threshold voltage $V_{ISNS(oc)}$ from the electrical specifications table. When this happens, the controller discharges the SS capacitor through a relatively high impedance and then attempts to restart. The amount of output current that causes this to happen is dependent on several variables in the converter.

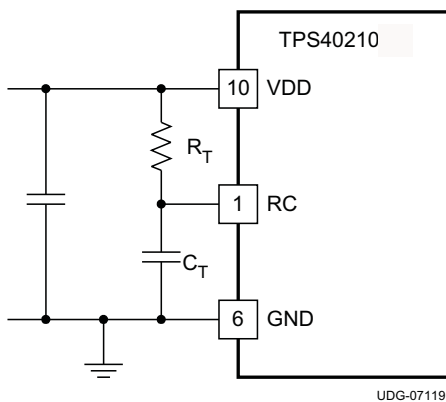

Figure 23. Oscillator Components

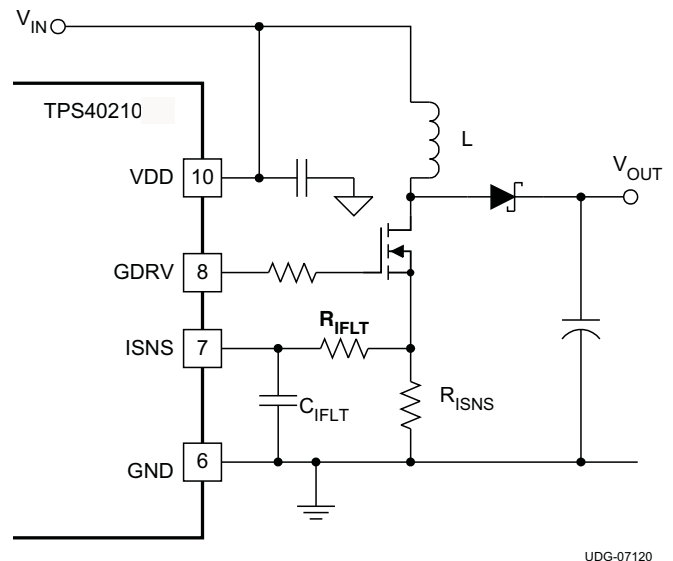

Figure 24. Current Sense Components

The load current overcurrent threshold is set by proper choice of R_{ISNS} . If the converter is operating in discontinuous mode the current sense resistor is found in [Equation 6](#).

$$R_{ISNS} = \frac{f_{SW} \times L \times V_{ISNS(oc)}}{\sqrt{2 \times L \times f_{SW} \times I_{OUT(oc)} \times (V_{OUT} + V_D - V_{IN})}} \quad (6)$$

If the converter is operating in continuous conduction mode R_{ISNS} can be found in [Equation 7](#).

$$R_{ISNS} = \frac{V_{ISNS}}{\left(\frac{I_{OUT}}{1-D}\right) + \left(\frac{I_{RIPPLE}}{2}\right)} = \frac{V_{ISNS}}{\left(\frac{I_{OUT}}{(1-D)}\right) + \left(\frac{D \times V_{IN}}{2 \times f_{SW} \times L}\right)}$$

where

- R_{ISNS} is the value of the current sense resistor in Ω .
- $V_{ISNS(oc)}$ is the overcurrent threshold voltage at the ISNS pin (from electrical specifications)
- D is the duty cycle (from [Equation 2](#))
- f_{SW} is the switching frequency in Hz
- V_{IN} is the input voltage to the power stage in V (see text)
- L is the value of the inductor in H
- $I_{OUT(oc)}$ is the desired overcurrent trip point in A
- V_D is the drop across the diode in [Figure 24](#)

The TPS40210 have a fixed undervoltage lockout (UVLO) that allows the controller to start at a typical input voltage of 4.25 V. If the input voltage is slowly rising, the converter might have less than its designed nominal input voltage available when it has reached regulation. As a result, this may decrease the apparent current-limit load current value and must be taken into consideration when selecting R_{ISNS} . The value of V_{IN} used to calculate R_{ISNS} must be the value at which the converter finishes startup. The total converter output current at startup is the sum of the external load current and the current required to charge the output capacitor(s). See the *Soft Start* section of this data sheet for information on calculating the required output capacitor charging current.

The topology of the standard boost converter has no method to limit current from the input to the output in the event of a short circuit fault on the output of the converter. If protection from this type of event is desired, it is necessary to use some secondary protection scheme such as a fuse or rely on the current limit of the upstream power source.

Current Sense and Sub-Harmonic Instability

A characteristic of peak current-mode control results in a condition where the current control loop can exhibit instability. This results in alternating long and short pulses from the pulse-width modulator. The voltage loop maintains regulation and does not oscillate, but the output ripple voltage increases. The condition occurs only when the converter is operating in continuous conduction mode, and the duty cycle is 50% or greater. The cause of this condition is described in Texas Instruments literature number [SLUA101](#), available at www.ti.com. The remedy for this condition is to apply a compensating ramp from the oscillator to the signal going to the pulse-width modulator. In the TPS40210, the oscillator ramp is applied in a fixed amount to the pulse-width modulator. The slope of the ramp is given in [Equation 8](#).

$$s_e = f_{SW} \times \left(\frac{V_{VDD}}{20}\right) \quad (8)$$

To ensure that the converter does not enter into sub-harmonic instability, the slope of the compensating ramp signal must be at least half of the down slope of the current ramp signal. Because the compensating ramp is fixed in the TPS40210, this places a constraint on the selection of the current sense resistor.

The down slope of the current sense wave form at the pulse-width modulator is described in [Equation 9](#).

$$m2 = \frac{A_{CS} \times R_{ISNS} \times (V_{OUT} + V_D - V_{IN})}{L} \quad (9)$$

Since the slope compensation ramp must be at least half, and preferably equal to the down slope of the current sense waveform seen at the pulse-width modulator, a maximum value is placed on the current sense resistor when operating in continuous mode at 50% duty cycle or greater. For design purposes, some margin should be applied to the actual value of the current sense resistor. As a starting point, the actual resistor chosen should be 80% or less that the value calculated in [Equation 10](#). This equation calculates the resistor value that makes the slope compensation ramp equal to one half of the current ramp downslope. Values no more than 80% of this result are acceptable.

$$R_{ISNS(max)} = \frac{V_{VDD} \times L \times f_{SW}}{60 \times (V_{OUT} + V_D - V_{IN})}$$

where

- S_e is the slope of the voltage compensating ramp applied to the pulse-width modulator in V/s
- f_{SW} is the switching frequency in Hz
- V_{VDD} is the voltage at the VDD pin in V
- m_2 is the down slope of the current sense waveform seen at the pulse-width modulator in V/s
- R_{ISNS} is the value of the current sense resistor in Ω
- V_{OUT} is the converter output voltage V_{IN} is the converter power stage input voltage
- V_D is the drop across the diode in [Figure 24](#) (10)

It is possible to increase the voltage compensation ramp slope by connecting the VDD pin to the output voltage of the converter instead of the input voltage as shown in [Figure 24](#). This can help in situations where the converter design calls for a large ripple current value in relation to the desired output current limit setting.

NOTE

Connecting the VDD pin to the output voltage of the converter affects the startup voltage of the converter since the controller undervoltage lockout (UVLO) circuit monitors the VDD pin and senses the input voltage less the diode drop before startup. The effect is to increase the startup voltage by the value of the diode voltage drop.

If an acceptable R_{ISNS} value is not available, the next higher value can be used and the signal from the resistor divided down to an acceptable level by placing another resistor in parallel with C_{ISNS} .

Current Sense Filtering

In most cases, a small filter placed on the ISNS pin improves performance of the converter. These are the components R_{IFLT} and C_{IFLT} in [Figure 24](#). The time constant of this filter should be approximately 10% of the nominal pulse width of the converter. The pulse width can be found using [Equation 11](#).

$$t_{ON} = \frac{D}{f_{SW}} \tag{11}$$

The suggested time constant is then

$$R_{IFLT} \times C_{IFLT} = 0.1 \times t_{ON} \tag{12}$$

The range of R_{IFLT} should be from about 1 k Ω to 5 k Ω for best results. Higher values can be used, but this raises the impedance of the ISNS pin connection more than necessary and can lead to noise-pickup issues in some layouts. C_{ISNS} should be located as close as possible to the ISNS pin as well to provide noise immunity.

Soft Start

The soft-start feature of the TPS40210 is a closed-loop soft start, meaning that the output voltage follows a linear ramp that is proportional to the ramp generated at the SS pin. This ramp is generated by an internal resistor connected from the BP pin to the SS pin and an external capacitor connected from the SS pin to GND. The SS pin voltage (V_{SS}) is level shifted down by approximately $V_{SS(ofst)}$ (approximately 1 V) and sent to one of the “+” inputs (the “+” input with the lowest voltage dominates) of the error amplifier. When this level-shifted voltage (V_{SSE}) starts to rise at time t_1 (see [Figure 25](#)), the output voltage that the controller expects rises as well. Since V_{SSE} starts at near 0 V, the controller attempts to regulate the output voltage from a starting point of zero volts. It

cannot do this, due to the converter architecture. The output voltage starts from the input voltage less the drop across the diode ($V_{IN} - V_D$) and rises from there. The point at which the output voltage starts to rise (t_2) is when the V_{SSE} ramp passes the point where it is commanding more output voltage than ($V_{IN} - V_D$). This voltage level is labeled $V_{SSE(1)}$. The time required for the output voltage to ramp from a theoretical zero to the final regulated value (from t_1 to t_3) is determined by the time it takes for the capacitor connected to the SS pin (C_{SS}) to rise through a 700-mV range, beginning at $V_{SS(ofst)}$ above GND.

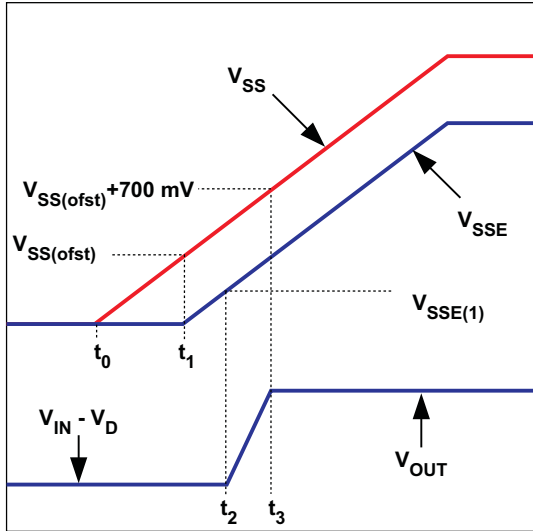
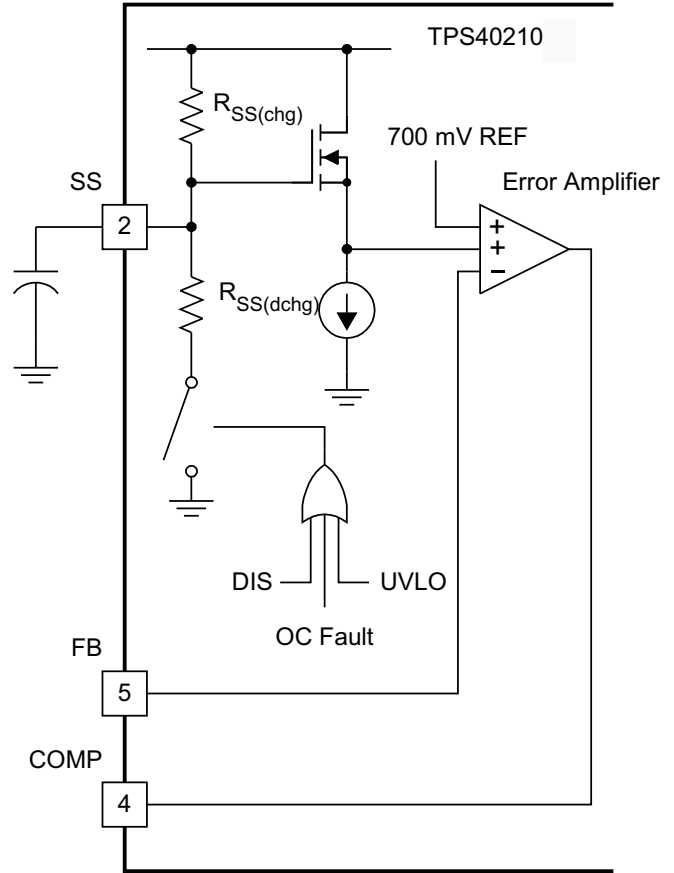

Figure 25. SS Pin Voltage and Output Voltage



UDG-07121

Figure 26. SS Pin Functional Circuit

The required capacitance for a given soft start time $t_3 - t_1$ in [Figure 25](#) is calculated in [Equation 13](#).

$$C_{SS} = \frac{t_{SS}}{R_{SS} \times \ln \left(\frac{V_{BP} - V_{SS(ofst)}}{V_{BP} - (V_{SS(ofst)} + V_{FB})} \right)}$$

where

- t_{SS} is the soft-start time
 - $R_{SS(chg)}$ is the SS charging resistance in Ω , typically 500 k Ω
 - C_{SS} is the value of the capacitor on the SS pin, in F
 - V_{BP} is the value of the voltage on the BP pin in V
 - $V_{SS(ofst)}$ is the approximate level shift from the SS pin to the error amplifier (~1 V)
 - V_{FB} is the error amplifier reference voltage, 700 mV typical
- (13)

Note that t_{SS} is the time it takes for the output voltage to rise from 0 V to the final output voltage. Also note the tolerance on $R_{SS(chg)}$ given in the electrical specifications table. This contributes to some variability in the output voltage rise time, and margin must be applied to account for it in design.

Also take note of V_{BP} . Its value varies depending on input conditions. For example, a converter operating from a slowly rising input initializes V_{BP} at a fairly low value and increases during the entire startup sequence. If the controller has a voltage above 8 V at the input and the DIS pin is used to stop and then restart the converter, V_{BP} is approximately 8 V for the entire startup sequence. The higher the voltage on BP, the shorter the startup time is and conversely, the lower the voltage on BP, the longer the startup time is.

The soft-start time (t_{SS}) must be chosen long enough so that the converter can start up without going into an overcurrent state. Since the overcurrent state is triggered by sensing the peak voltage on the ISNS pin, that voltage must be kept below the overcurrent threshold voltage $V_{ISNS(oc)}$. The voltage on the ISNS pin is a function of the load current of the converter, the rate of rise of the output voltage and the output capacitance, and the current sensing resistor. The total output current that must be supported by the converter is the sum of the charging current required by the output capacitor and any external load that must be supplied during startup. This current must be less than the $I_{OUT(oc)}$ value used in [Equation 6](#) or [Equation 7](#) (depending on the operating mode of the converter) to determine the current sense resistor value.

In these equations, the actual input voltage at the time that the controller reaches the final output voltage is the important input voltage to use in the calculations. If the input voltage is slowly rising and is at less than the nominal input voltage when the startup time ends, the output current limit is less than $I_{OUT(oc)}$ at the nominal input voltage. The output capacitor charging current must be reduced (decrease C_{OUT} or increase the t_{SS}) or $I_{OUT(oc)}$ must be increased and a new value for R_{ISNS} calculated.

$$I_{C(chg)} = \left[\frac{C_{OUT} \times V_{OUT}}{t_{SS}} \right]$$
(14)

$$t_{SS} > \left[\frac{C_{OUT} \times V_{OUT}}{(I_{OUT(oc)} - I_{EXT})} \right]$$

where

- $I_{C(chg)}$ is the output capacitor charging current in A
 - C_{OUT} is the total output capacitance in F
 - V_{OUT} is the output voltage in V
 - t_{SS} is the soft start time from [Equation 13](#)
 - $I_{OUT(oc)}$ is the desired over current trip point in A
 - I_{EXT} is any external load current in A
- (15)

The capacitor on the SS pin (C_{SS}) also plays a role in overcurrent functionality. It is used as the timer between restart attempts. The SS pin is connected to GND through a resistor, $R_{SS(dchg)}$, when the controller senses an overcurrent condition. Switching stops and nothing else happens until the SS pin discharges to the soft-start reset threshold, $V_{SS(rst)}$. At this point, the SS pin capacitor is allowed to charge again through the charging resistor $R_{SS(chg)}$, and the controller restarts from that point. The shortest time between restart attempts occurs when the SS pin discharges from $V_{SS(ofst)}$ (approximately 1 V) to $V_{SS(rst)}$ (150 mV) and then back to $V_{SS(ofst)}$ and switching resumes. In actuality, this is a conservative estimate since switching does not resume until the V_{SSE} ramp rises to a point where it is commanding more output voltage than exists at the output of the controller. This occurs at some SS pin voltage greater than $V_{SS(ofst)}$ and depends on the voltage that remains on the output overvoltage the converter while switching has been halted. The fastest restart time can be calculated by using [Equation 16](#), [Equation 17](#), and [Equation 18](#).

$$t_{DCHG} = R_{SS(dchg)} \times C_{SS} \times \ln \left(\frac{V_{SS(ofst)}}{V_{SS(rst)}} \right) \tag{16}$$

$$t_{CHG} = R_{SS(chg)} \times C_{SS} \times \ln \left(\frac{(V_{BP} - V_{SS(rst)})}{(V_{BP} - V_{SS(ofst)})} \right) \tag{17}$$

$$t_{RSTRT(min)} = t_{CHG} + t_{DCHG} \tag{18}$$

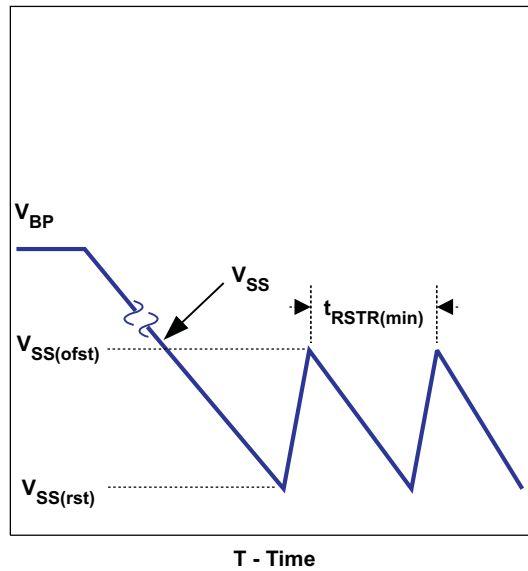

Figure 27. Soft Start During Overcurrent

BP Regulator

The TPS40210 has an on-board linear regulator that supplies power for the internal circuitry of the controller, including the gate driver. This regulator has a nominal output voltage of 8 V and must be bypassed with a 1- μ F capacitor. If the voltage at the VDD pin is less than 8 V, the voltage on the BP pin is also less, and the gate drive voltage to the external FET is reduced from the nominal 8 V. This should be considered when choosing a FET for the converter.

Connecting external loads to this regulator can be done, but care must be taken to ensure that the thermal rating of the device is observed, because there is no thermal shutdown feature in this controller. Exceeding the thermal ratings causes out-of-specification behavior and can lead to reduced reliability. The controller dissipates more power when there is an external load on the BP pin and is tested for dropout voltage for up to 5-mA load. When the controller is in the disabled state, the BP pin regulator also shuts off so loads connected there power down as well. When the controller is disabled with the DIS/EN pin, this regulator is turned off.

The total power dissipation in the controller can be calculated as follows. The total power is the sum of P_Q , P_G and P_E .

$$P_Q = V_{VDD} \times I_{VDD(en)} \quad (19)$$

$$P_G = V_{VDD} \times Q_g \times f_{SW} \quad (20)$$

$$P_E = V_{VDD} \times I_{EXT}$$

where

- P_Q is the quiescent power of the device in W
 - V_{VDD} is the VDD pin voltage in V
 - $I_{VDD(en)}$ is the quiescent current of the controller when enabled but not switching in A
 - P_G is the power dissipated by driving the gate of the FET in W
 - Q_g is the total gate charge of the FET at the voltage on the BP pin in C
 - f_{SW} is the switching frequency in Hz
 - P_E is the dissipation caused by external loading of the BP pin in W
 - I_{EXT} is the external load current in A
- (21)

Shutdown (DIS/EN Pin)

The DIS/EN pin is an active-high shutdown command for the controller. Pulling this pin above 1.2 V causes the controller to completely shut down and enter a low current consumption state. In this state, the regulator connected to the BP pin is turned off. There is an internal 1.1-M Ω pull-down resistor connected to this pin that keeps the pin at GND level when left floating. If this function is not used in an application, it is best to connect this pin to GND.

Control Loop Considerations

There are two methods to design a suitable control loop for the TPS40210. The first (and preferred, if equipment is available) is to use a frequency-response analyzer to measure the open-loop modulator and power stage gain and to then design compensation to fit that. The usage of these tools for this purpose is well documented with the literature that accompanies the tool and is not discussed here.

The second option is to make an initial guess at compensation, and then evaluate the transient response of the system to see if the compensation is acceptable to the application or not. For most systems, an adequate response can be obtained by simply placing a series resistor and capacitor (R_{FB} and C_{FB}) from the COMP pin to the FB pin as shown in Figure 28.

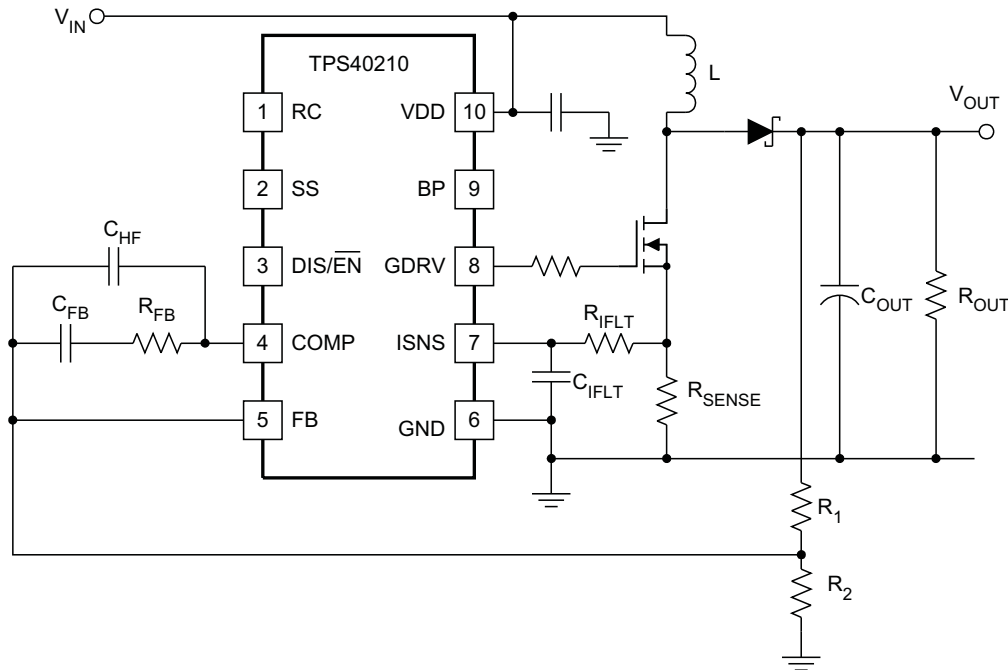

UDG-07177

Figure 28. Basic Compensation Network

The natural phase characteristics of most capacitors used for boost outputs combined with the current mode control provide adequate phase margin when using this type of compensation. To determine an initial starting point for the compensation, the desired crossover frequency must be considered when estimating the control to output gain. The model used is a current source into the output capacitor and load.

When using these equations, the loop bandwidth should be no more than 20% of the switching frequency, f_{SW} . A more reasonable loop bandwidth would be 10% of the switching frequency. Be sure to evaluate the transient response of the converter over the expected load range to ensure acceptable operation.

$$|K_{CO}| = g_M \times |Z_{OUT}(f_{CO})| = 19.1 \frac{A}{V} \times 0.146 \Omega = 2.80 \tag{22}$$

$$g_M = \frac{0.13 \times \sqrt{L \times \frac{f_{SW}}{R_{OUT}}}}{(R_{ISNS})^2 \times (120 \times R_{ISNS} + L \times f_{SW})} = \frac{0.13 \times \sqrt{10 \mu H \times \frac{600 \text{ kHz}}{240 \Omega}}}{(12 \text{ m}\Omega)^2 \times (120 \times 12 \text{ m}\Omega + 10 \mu H \times 600 \text{ kHz})} = 19.1 \frac{A}{V} \tag{23}$$

$$|Z_{OUT}| = R_{OUT} \times \sqrt{\frac{\left(1 + (2\pi \times f_L \times R_{ESR} \times C_{OUT})^2\right)}{1 + \left(R_{OUT}\right)^2 + 2 \times R_{OUT} \times R_{ESR} + \left(R_{ESR}\right)^2} \times (2\pi \times f_L \times C_{OUT})^2}$$

where

- K_{CO} is the control to output gain of the converter, in V/V
- g_M is the transconductance of the power stage and modulator, in S
- R_{OUT} is the output load equivalent resistance, in Ω
- Z_{OUT} is the output impedance, including the output capacitor, in Ω
- R_{SNS} is the value of the current sense resistor, in Ω
- L is the value of the inductor, in H
- C_{OUT} is the value of the output capacitance, in μF
- R_{ESR} is the equivalent series resistance of C_{OUT} , in Ω
- f_{SW} is the switching frequency, in Hz
- f_L is the desired crossover frequency for the control loop, in Hz

(24)

These equations assume that the operation is discontinuous and that the load is purely resistive. The gain in continuous conduction can be found by evaluating [Equation 23](#) at the resistance that gives the critical conduction current for the converter. Loads that are more like current sources give slightly higher gains than predicted here. To find the gain of the compensation network required for a control loop of bandwidth f_L , take the reciprocal of [Equation 22](#).

$$K_{COMP} = \frac{1}{|K_{CO}|} = \frac{1}{2.80} = 0.356$$

(25)

The GBWP of the error amplifier is only specified to be at least 1.5 MHz. If K_{COMP} multiplied by the f_L is greater than 750 kHz, reduce the desired loop crossover frequency until this condition is satisfied. This ensures that the high-frequency pole from the error amplifier response with the compensation network in place does not cause excessive phase lag at the f_L and decrease phase margin in the loop.

The R-C network connected from COMP to FB places a zero in the compensation response. That zero should be approximately $1/10^{\text{th}}$ of the desired crossover frequency, f_L . With that being the case, R_{FB} and C_{FB} can be found from [Equation 26](#) and [Equation 27](#)

$$R_{FB} = \frac{R1}{|K_{CO}|} = R1 \times K_{COMP}$$

(26)

$$C_{FB} = \frac{10}{2\pi \times f_L \times R_{FB}}$$

where

- $R1$ is in f_L is the loop crossover frequency desired, in Hz.
- R_{FB} is the feedback resistor in C_{FB} is the feedback capacitance in μF .

(27)

Though not strictly necessary, it is recommended that a capacitor be added between COMP and FB to provide high-frequency noise attenuation in the control loop circuit. This capacitor introduces another pole in the compensation response. The allowable location of that pole frequency determines the capacitor value. As a starting point, the pole frequency should be $10 \times f_L$. The value of C_{HF} can be found from [Equation 28](#).

$$C_{HF} = \frac{1}{20\pi \times f_L \times R_{FB}}$$

(28)

The error amplifier GBWP will usually be higher, but is ensured by design to be at least 1.5 MHz. If the gain required in Equation 25 multiplied by 10 times the desired control loop crossover frequency, the high-frequency pole introduced by C_{HF} is overridden by the error amplifier capability and the effective pole is lower in frequency. If this is the case, C_{HF} can be made larger to provide a consistent high-frequency roll off in the control loop design. Equation 29 calculates the required C_{HF} in this case.

$$C_{HF} = \frac{1}{2\pi \times 1.5 \times (10)^6 \times R_{FB}}$$

where

- C_{HF} is the high-frequency roll-off capacitor value in μF
 - R_{FB} is the mid-band gain-setting resistor value in Ω
- (29)

Gate Drive Circuit

Some applications benefit from the addition of a resistor connected between the GDRV pin and the gate of the switching MOSFET. In applications that have particularly stringent load regulation (under 0.75%) requirements and operate from input voltages above 5 V, or are sensitive to pulse jitter in the discontinuous conduction region, this resistor is recommended. The recommended starting point for the value of this resistor can be calculated from Equation 30.

$$R_G = \frac{105}{Q_G}$$

where

- Q_G is the MOSFET total gate charge at 8-V V_{GS} in nC.
 - R_G is the suggested starting point gate resistance in Ω .
- (30)

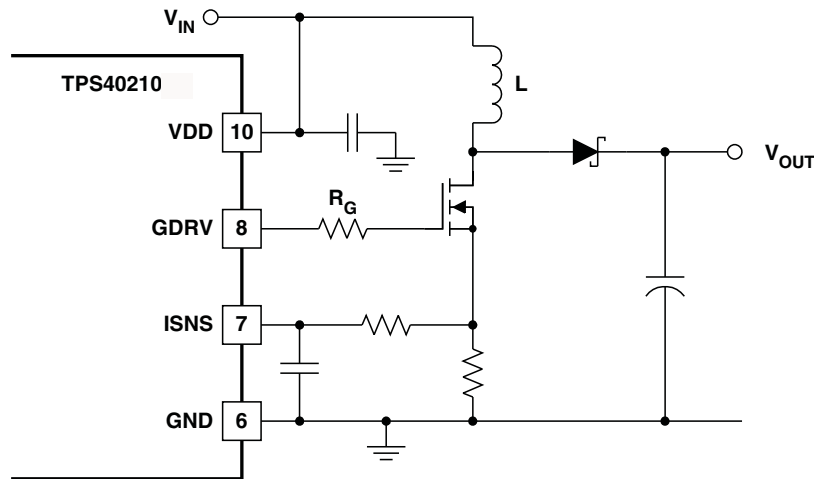

UDG-07196

Figure 29. Gate Drive Resistor

TPS40211

The only difference between the TPS40210 and the TPS40211 is the reference voltage that the error amplifier uses to regulate the output voltage. The TPS40211 uses a 260-mV reference and is intended for applications where the output is actually a current instead of a regulated voltage. A typical example of an application of this type is an LED driver. An example schematic is shown in Figure 30.

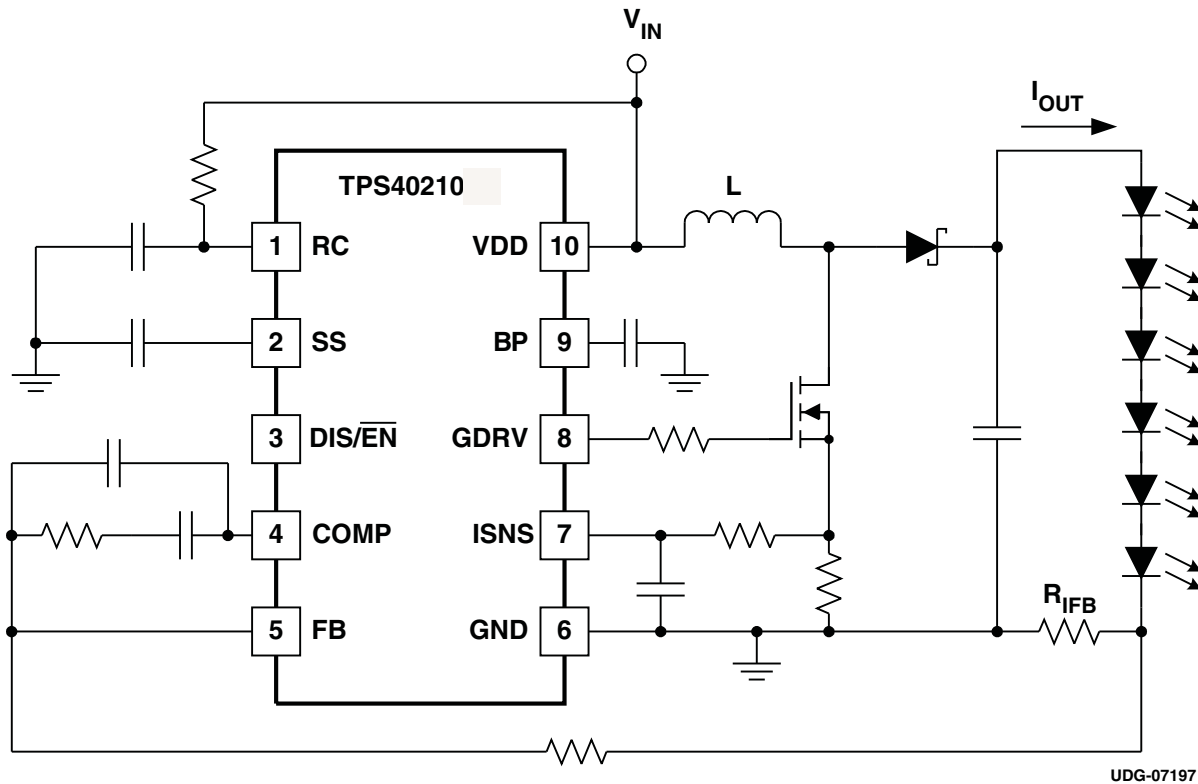

Figure 30. Typical LED Drive Schematic

The current in the LED string is set by the choice of the resistor R_{ISNS} as shown in Equation 31.

$$R_{IFB} = \frac{V_{FB}}{I_{OUT}}$$

where

- R_{IFB} is the value of the current sense resistor for the LED string in Ω .
- V_{FB} is the reference voltage for the TPS40211 in V (0.260 V typ).
- I_{OUT} is the desired DC current in the LED string in A.

(31)

ADDITIONAL REFERENCES

References

These references may be found on the web at www.power.ti.com under Technical Documents. Many design tools and links to additional references, may also be found at www.power.ti.com

1. *Design and Application Guide for High Speed MOSFET Gate Drive Circuits*, SEM 1400, 2001 Seminar Series
2. *Designing Stable Control Loops*, SEM 1400, 2001 Seminar Series
3. Additional PowerPAD™ information may be found in Applications Briefs SLMA002 and SLMA004
4. QFN/SON PCB Attachment, Texas Instruments Literature Number SLUA271, June 2002

DESIGN EXAMPLE 1

12-V to 24-V Non-Synchronous Boost Regulator

The following example illustrates the design process and component selection for a 12-V to 24-V non-synchronous boost regulator using the TPS40210 controller.

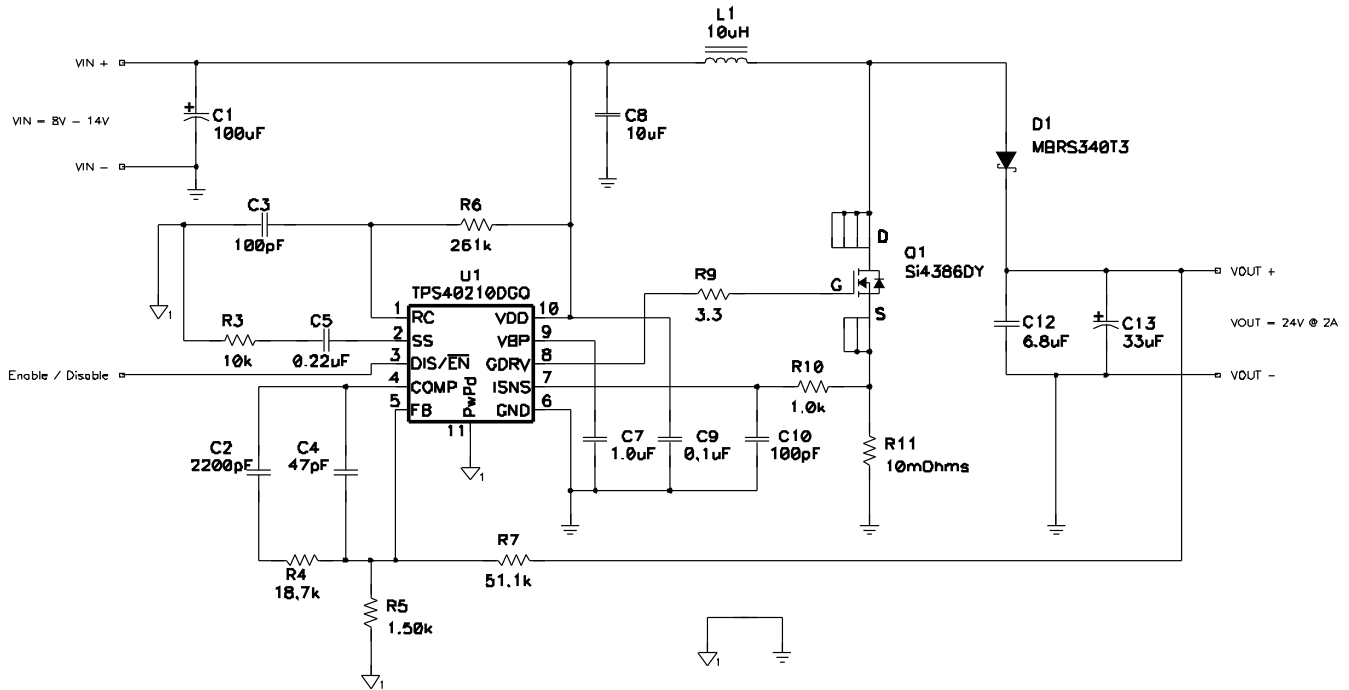

Figure 31. TPS40210 Design Example – 8-V to 24-V at 2-A

Table 2. TPS40210 Design Example Specifications

PARAMETER		CONDITIONS	MIN	NOM	MAX	UNIT
INPUT CHARACTERISTICS						
V _{IN}	Input voltage		8	12	14	V
I _{IN}	Input current		4.4			A
	No load input current		0.05			
V _{IN(UVLO)}	Input undervoltage lockout		4.5			V
OUTPUT CHARACTERISTICS						
V _{OUT}	Output voltage		23.5	24.0	24.5	V
	Line regulation				1%	
	Load regulation				1%	
V _{OUT(ripple)}	Output voltage ripple				500	mV _{PP}
I _{OUT}	Output current	8 V ≤ V _{IN} ≤ 14 V	0.2	1	2	A
I _{OC}	Output overcurrent inception point		3.5			
	Transient response					
ΔI	Load step		1			A
	Load slew rate		1			A/μs
	Overshoot threshold voltage		500			mV
	Settling time		5			ms

Table 2. TPS40210 Design Example Specifications (continued)

PARAMETER		CONDITIONS	MIN	NOM	MAX	UNIT
SYSTEM CHARACTERISTICS						
f _{SW}	Switching frequency			600		kHz
η _{PK}	Peak efficiency	V _{IN} = 12 V, 0.2 A ≤ I _{OUT} ≤ 2 A		95%		
η	Full load efficiency	V _{IN} = 12 V, I _{OUT} = 2 A		94%		
T _{OP}	Operating temperature range	10 V ≤ V _{IN} ≤ 14 V, 0.2 A ≤ I _{OUT} ≤ 2 A		25		°C
MECHANICAL DIMENSIONS						
W	Width			1.5		in
L	Length			1.5		
h	Height			0.5		

Step-By-Step Design Procedure

Duty Cycle Estimation

The duty cycle of the main switching MOSFET is estimated using [Equation 32](#) and [Equation 33](#).

$$D_{MIN} \approx \frac{V_{OUT} - V_{IN(max)} + V_{FD}}{V_{OUT} + V_{FD}} = \frac{24\text{ V} - 14\text{ V} + 0.5\text{ V}}{24\text{ V} + 0.5\text{ V}} = 42.8\% \tag{32}$$

$$D_{MAX} \approx \frac{V_{OUT} - V_{IN(min)} + V_{FD}}{V_{OUT} + V_{FD}} = \frac{24\text{ V} - 8\text{ V} + 0.5\text{ V}}{24\text{ V} + 0.5\text{ V}} = 67.3\% \tag{33}$$

Using an estimated forward drop of 0.5 V for a Schottky rectifier diode, the approximate duty cycle is 42.8% (minimum) to 67.3% (maximum).

Inductor Selection

The peak-to-peak ripple is limited to 30% of the maximum output current.

$$I_{Lrip(max)} = 0.3 \times \frac{I_{OUT(max)}}{1 - D_{MIN}} = 0.3 \times \frac{2}{1 - 0.428} = 1.05\text{ A} \tag{34}$$

The minimum inductor size can be estimated using [Equation 35](#).

$$L_{MIN} \gg \frac{V_{IN(max)}}{I_{Lrip(max)}} \times D_{MIN} \times \frac{1}{f_{SW}} = \frac{14\text{ V}}{1.05\text{ A}} \times 0.428 \times \frac{1}{600\text{ kHz}} = 9.5\text{ }\mu\text{H} \tag{35}$$

The next higher standard inductor value of 10 μH is selected. The ripple current is estimated by [Equation 36](#).

$$I_{RIPPLE} \approx \frac{V_{IN}}{L} \times D \times \frac{1}{f_{SW}} = \frac{12\text{ V}}{10\text{ }\mu\text{H}} \times 0.50 \times \frac{1}{600\text{ kHz}} = 1.02\text{ A} \tag{36}$$

$$I_{RIPPLE(Vinmin)} \approx \frac{V_{IN}}{L} \times D \times \frac{1}{f_{SW}} = \frac{8\text{ V}}{10\text{ }\mu\text{H}} \times 0.673 \times \frac{1}{600\text{ kHz}} = 0.89\text{ A} \tag{37}$$

The worst-case peak-to-peak ripple current occurs at 50% duty cycle and is estimated as 1.02 A. Worst-case RMS current through the inductor is approximated by [Equation 38](#).

$$I_{Lrms} = \sqrt{\left(I_{L(avg)}\right)^2 + \left(\frac{1}{12}I_{RIPPLE}\right)^2} \approx \sqrt{\left(\frac{I_{OUT(max)}}{1 - D_{MAX}}\right)^2 + \left(\frac{1}{12}I_{RIPPLE(Vinmin)}\right)^2} = \sqrt{\left(\frac{2}{1 - 0.673}\right)^2 + \left(\left(\frac{1}{12}\right) \times 0.817\text{ A}\right)^2} = 6.13\text{ Arms} \tag{38}$$

The worst case RMS inductor current is 6.13 Arms. The peak inductor current is estimated by [Equation 39](#).

$$I_{L(\text{peak})} \approx \frac{I_{\text{OUT}(\text{max})}}{1 - D_{\text{MAX}}} + \left(\frac{1}{2}\right)_{\text{RIPPLE}}(V_{\text{inmin}}) = \frac{2}{1 - 0.673} + \left(\frac{1}{2}\right)0.718 = 6.57 \text{ A} \quad (39)$$

A 10- μH inductor with a minimum RMS current rating of 6.13 A and minimum saturation current rating of 6.57 A must be selected. A TDK RLF12560T-100M-7R5 7.5-A 10- μH inductor is selected.

This inductor power dissipation is estimated by [Equation 40](#).

$$P_L \approx (I_{L(\text{rms})})^2 \times \text{DCR} \quad (40)$$

The TDK RLF12560T-100M-7R5 12.4-m Ω DCR dissipates 466 mW of power.

Rectifier Diode Selection

A low-forward voltage drop Schottky diode is used as a rectifier diode to reduce its power dissipation and improve efficiency. Using 80% derating, on V_{OUT} for ringing on the switch node, the rectifier diode minimum reverse break-down voltage is given by [Equation 41](#).

$$V_{(\text{BR})\text{R}(\text{min})} \geq \frac{V_{\text{OUT}}}{0.8} = 1.25 \times V_{\text{OUT}} = 1.25 \times 24 \text{ V} = 30 \text{ V} \quad (41)$$

The diode must have reverse breakdown voltage greater than 30 V. The rectifier diode peak and average currents are estimated by [Equation 42](#) and [Equation 43](#).

$$I_{D(\text{avg})} \approx I_{\text{OUT}(\text{max})} = 2 \text{ A} \quad (42)$$

$$I_{D(\text{peak})} = I_{L(\text{peak})} = 6.57 \text{ A} \quad (43)$$

For this design, 2-A average and 6.57-A peak is

The power dissipation in the diode is estimated by [Equation 44](#).

$$P_{D(\text{max})} \approx V_F \times I_{\text{OUT}(\text{max})} = 0.5 \text{ V} \times 2 \text{ A} = 1 \text{ W} \quad (44)$$

For this design, the maximum power dissipation is estimated as 1 W. Reviewing 30-V and 40-V Schottky diodes, the MBRS340T3 40-V 3-A diode in an SMC package is selected. This diode has a forward voltage drop of 0.48 V at 6 A, so the conduction power dissipation is approximately 960 mW, less than half its rated power dissipation.

Output Capacitor Selection

Output capacitors must be selected to meet the required output ripple and transient specifications.

$$C_{\text{OUT}} = 8 \frac{I_{\text{OUT}} \times D}{V_{\text{OUT}(\text{ripple})}} \times \frac{1}{f_{\text{SW}}} = 8 \left(\frac{2 \text{ A} \times 0.673}{500 \text{ mV}} \right) \times \frac{1}{600 \text{ kHz}} = 35 \mu\text{F} \quad (45)$$

$$\text{ESR} = \frac{7}{8} \times \frac{V_{\text{OUT}(\text{ripple})}}{I_{L(\text{peak})} - I_{\text{OUT}}} = \frac{7}{8} \times \frac{500 \text{ mV}}{6.57 \text{ A} - 2 \text{ A}} = 95 \text{ m}\Omega \quad (46)$$

A Panasonic EEEFC1V330P 35-V 33- μF , 120-m Ω bulk capacitor and 6.8- μF ceramic capacitor is selected to provide the required capacitance and ESR at the switching frequency. The combined capacitances of 39.8 μF and 60 m Ω are used in compensation calculations.

Input Capacitor Selection

Since a boost converter has continuous input current, the input capacitor senses only the inductor ripple current. The input capacitor value can be calculated by [Equation 47](#) and [Equation 48](#).

$$C_{IN} > \frac{I_{L(\text{ripple})}}{4 \times V_{IN(\text{ripple})} \times f_{SW}} = \frac{1.02 \text{ A}}{4 \times 60 \text{ mV} \times 600 \text{ kHz}} = 7.0 \mu\text{F} \quad (47)$$

$$ESR < \frac{V_{IN(\text{ripple})}}{2 \times I_{L(\text{ripple})}} = \frac{60 \text{ mV}}{2 \times 1.02 \text{ A}} = 30 \text{ m}\Omega \quad (48)$$

For this design, to meet a maximum input ripple of 60 mV, a minimum 7.0- μF input capacitor with ESR less than 30 m Ω is needed. A 10- μF X7R ceramic capacitor is selected.

Current Sense and Current Limit

The maximum allowable current sense resistor value is limited by both the current limit and sub-harmonic stability. These two limitations are given by [Equation 49](#) and [Equation 50](#).

$$R_{ISNS} < \frac{V_{OCP(\text{min})}}{1.1 \times (I_{L(\text{peak})} + I_{\text{Drive}})} = \frac{110 \text{ mV}}{1.1 \times 6.57 \text{ A} + 0.50 \text{ A}} = 14.2 \text{ m}\Omega \quad (49)$$

$$R_{ISNS} < \frac{V_{DD\text{MAX}} \times L \times f_{SW}}{60 \times (V_{OUT} + V_{fd} - V_{IN})} = \frac{14 \text{ V} \times 10 \mu\text{H} \times 600 \text{ kHz}}{60 \times (24 \text{ V} + 0.48 \text{ V} - 14 \text{ V})} = 133 \text{ m}\Omega \quad (50)$$

The current limit requires a resistor less than 14.2 m Ω , and stability requires a sense resistor less than 133 m Ω . A 10-m Ω resistor is selected. Approximately 2-m Ω of routing resistance is added in compensation calculations.

Current Sense Filter

To remove switching noise from the current sense, an R-C filter is placed between the current sense resistor and the ISNS pin. A resistor with a value between 1 k Ω and 5 k Ω is selected, and a capacitor value is calculated by [Equation 51](#).

$$C_{IFLT} = \frac{0.1 \times D_{\text{MIN}}}{f_{SW} \times R_{IFLT}} = \frac{0.1 \times 0.428}{600 \text{ kHz} \times 1 \text{ k}\Omega} = 71 \text{ pF} \quad (51)$$

For a 1-k Ω filter resistor, 71 pF is calculated and a 100-pF capacitor is selected.

Switching MOSFET Selection

The TPS40210 drives a ground referenced N-channel FET. The $R_{DS(\text{on})}$ and gate charge are estimated based on the desired efficiency target.

$$P_{\text{DISS}(\text{total})} \approx P_{\text{OUT}} \times \left(\frac{1}{\eta} - 1 \right) = V_{\text{OUT}} \times I_{\text{OUT}} \times \left(\frac{1}{\eta} - 1 \right) = 24 \text{ V} \times 2 \text{ A} \times \left(\frac{1}{0.95} - 1 \right) = 2.526 \text{ W} \quad (52)$$

For a target of 95% efficiency with a 24-V input voltage at 2 A, maximum power dissipation is limited to 2.526 W. The main power dissipating devices are the MOSFET, inductor, diode, current sense resistor and the integrated circuit, the TPS40210.

$$P_{\text{FET}} < P_{\text{DISS}(\text{total})} - P_L - P_D - P_{\text{Risns}} - V_{IN(\text{max})} \times I_{VDD} \quad (53)$$

This leaves 740 mW of power dissipation for the MOSFET. This can likely cause an SO-8 MOSFET to get too hot, so power dissipation is limited to 500 mW. Allowing half for conduction and half for switching losses, we can determine a target $R_{DS(\text{on})}$ and Q_{GS} for the MOSFET by [Equation 54](#) and [Equation 55](#).

$$Q_{GS} < \frac{3 \times P_{\text{FET}} \times I_{\text{DRIVE}}}{2 \times V_{\text{OUT}} \times I_{\text{OUT}} \times f_{SW}} = \frac{3 \times 0.50 \text{ W} \times 0.50 \text{ A}}{2 \times 24 \text{ V} \times 2 \text{ A} \times 600 \text{ kHz}} = 13.0 \text{ nC} \quad (54)$$

A target MOSFET gate-to-source charge of less than 13.0 nC is calculated to limit the switching losses to less than 250 mW.

$$R_{DS(on)} < \frac{P_{FET}}{2 \times (I_{RMS})^2 \times D} = \frac{0.50 \text{ W}}{2 \times 6.13^2 \times 0.674} = 9.8 \text{ m}\Omega \quad (55)$$

A target MOSFET $R_{DS(on)}$ of 9.8 m Ω is calculated to limit the conduction losses to less than 250 mW. Reviewing 30-V and 40-V MOSFETs, an Si4386DY 9-m Ω MOSFET is selected. A gate resistor was added per [Equation 30](#). The maximum gate charge at $V_{gs} = 8 \text{ V}$ for the Si4386DY is 33.2 nC, this implies $R_G = 3.3 \Omega$.

Feedback Divider Resistors

The primary feedback divider resistor (R_{FB}) from V_{OUT} to FB should be selected between 10-k Ω and 100-k Ω to maintain a balance between power dissipation and noise sensitivity. For a 24-V output a high feedback resistance is desirable to limit power dissipation so $R_{FB} = 51.1 \text{ k}\Omega$ is selected.

$$R_{BIAS} = \frac{V_{FB} \times R_{FB}}{V_{OUT} - V_{FB}} = \frac{0.700 \text{ V} \times 51.1 \text{ k}\Omega}{24 \text{ V} - 0.700 \text{ V}} = 1.53 \text{ k}\Omega \quad (56)$$

$R_{BIAS} = 1.50 \text{ k}\Omega$ is selected.

Error Amplifier Compensation

While current mode control typically requires only Type II compensation, it is desirable to layout for Type III compensation to increase flexibility during design and development.

Current mode control boost converters have higher gain with higher output impedance, so it is necessary to calculate the control loop gain at the maximum output impedance, estimated by [Equation 57](#).

$$R_{OUT(max)} = \frac{V_{OUT}}{I_{OUT(min)}} = \frac{24 \text{ V}}{0.1 \text{ A}} = 240 \Omega \quad (57)$$

The transconductance of the TPS40210 current mode control can be estimated by [Equation 58](#).

$$g_M = \frac{0.13 \times \sqrt{L \times \frac{f_{SW}}{R_{OUT}}}}{(R_{ISNS})^2 \times (120 \times R_{ISNS} + L \times f_{SW})} = \frac{0.13 \times \sqrt{10 \mu\text{H} \times \frac{600 \text{ kHz}}{240 \Omega}}}{(12 \text{ m}\Omega)^2 \times (120 \times 12 \text{ m}\Omega + 10 \mu\text{H} \times 600 \text{ kHz})} = 19.1 \text{ A/V} \quad (58)$$

The maximum output impedance Z_{OUT} , can be estimated by [Equation 59](#).

$$|Z_{OUT}(f)| = R_{OUT} \times \sqrt{\frac{(1 + (2\pi \times f \times R_{ESR} \times C_{OUT})^2)}{1 + ((R_{OUT})^2 + 2 \times R_{OUT} \times R_{ESR} + (R_{ESR})^2) \times (2\pi \times f \times C_{OUT})^2}} \quad (59)$$

$$|Z_{OUT}(f_{CO})| = 240 \Omega \times \sqrt{\frac{(1 + (2\pi \times 20 \text{ kHz} \times 60 \text{ m}\Omega \times 39.8 \mu\text{F})^2)}{1 + ((240 \Omega)^2 + 2 \times 240 \Omega \times 60 \text{ m}\Omega + (60 \text{ m}\Omega)^2) \times (2\pi \times 20 \text{ kHz} \times 39.8 \mu\text{F})^2}} = 0.146 \Omega \quad (60)$$

The modulator gain at the desired cross-over can be estimated by [Equation 61](#).

$$|K_{CO}| = g_M \times |Z_{OUT}(f_{CO})| = 19.1 \text{ A/V} \times 0.146 \Omega = 2.80 \quad (61)$$

The feedback compensation network needs to be designed to provide an inverse gain at the cross-over frequency for unit loop gain. This sets the compensation mid-band gain at a value calculated in [Equation 62](#).

$$K_{COMP} = \frac{1}{|K_{CO}|} = \frac{1}{2.80} = 0.356 \quad (62)$$

To set the mid-band gain of the error amplifier to K_{COMP} use [Equation 63](#).

$$R4 = R7 \times K_{\text{COMP}} = \frac{R7}{|K_{\text{CO}}|} = \frac{51.1\text{k}\Omega}{2.80} = 18.2\text{k}\Omega \quad (63)$$

$R4 = 18.7\text{ k}\Omega$ selected.

Place the zero at 10th the desired cross-over frequency.

$$C2 = \frac{10}{2\pi \times f_L \times R4} = \frac{10}{2\pi \times 30\text{kHz} \times 18.7\text{k}\Omega} = 2837\text{ pF} \quad (64)$$

$C2 = 2200\text{ pF}$ selected.

Place a high-frequency pole at about five times the desired cross-over frequency and less than one-half the unity gain bandwidth of the error amplifier:

$$C4 \approx \frac{1}{10\pi \times f_L \times R4} = \frac{1}{10\pi \times 30\text{kHz} \times 18.7\text{k}\Omega} = 56.74\text{ pF} \quad (65)$$

$$C4 > \frac{1}{\pi \times \text{GBW} \times R4} = \frac{1}{\pi \times 1.5\text{MHz} \times 18.7\text{k}\Omega} = 11.35\text{ pF} \quad (66)$$

$C4 = 47\text{ pF}$ selected.

R-C Oscillator

The R-C oscillator calculation as shown in [Equation 5](#) substitutes 100 for C_T and 600 for f_{SW} . For a 600-kHz switching frequency, a 100-pF capacitor is selected and a 262-k Ω resistor is calculated (261 k Ω selected).

Soft-Start Capacitor

Because $V_{\text{DD}} > 8\text{ V}$, the soft-start capacitor is selected by using [Equation 67](#) to calculate the value.

$$C_{\text{SS}} = 20 \times T_{\text{SS}} \times 10^{-6} \quad (67)$$

For $T_{\text{SS}} = 12\text{ ms}$, $C_{\text{SS}} = 240\text{ nF}$, a 220-nF capacitor selected.

Regulator Bypass

A regulator bypass capacitor of 1.0- μF is selected per the recommendation.

TEST DATA

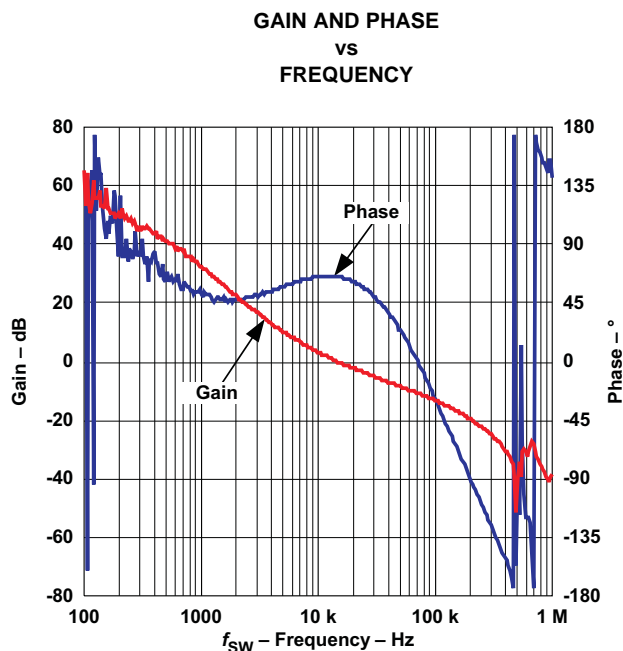

Figure 32.

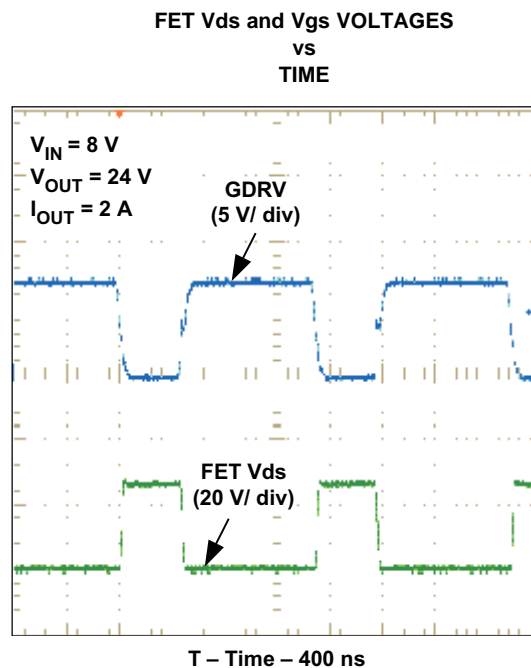

Figure 33.

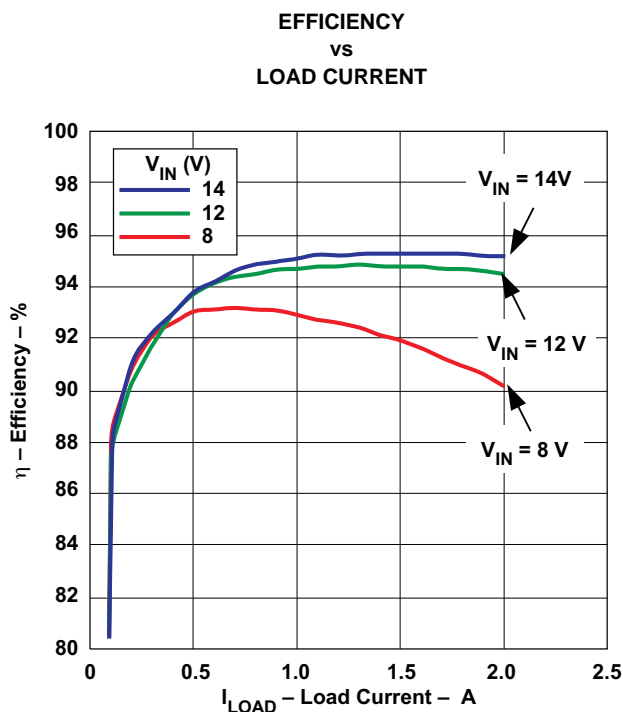

Figure 34.

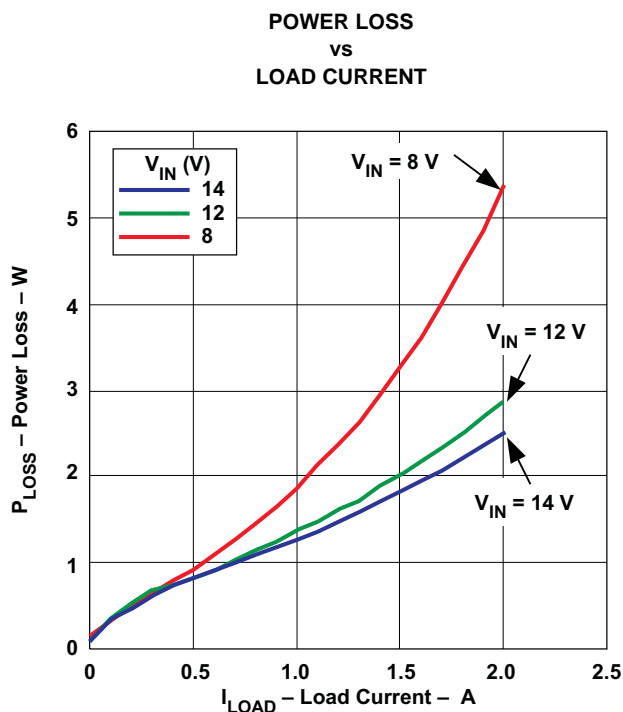

Figure 35.

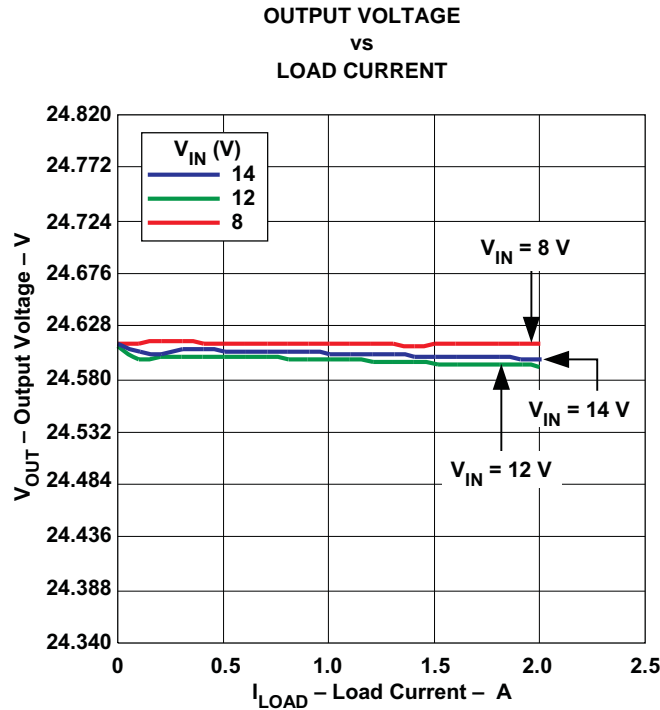

Figure 36.

List of Materials

Table 3. List of Materials, Design Example 1

REFERENCE DESIGNATOR	DESCRIPTION	SIZE	PART NUMBER	MANUFACTURER
C1	100 μF, aluminum capacitor, SM, ± 20%, 35 V	0.406 x 0.457	EEEF1V101P	Panasonic
C2	2200 pF, ceramic capacitor, 25 V, X7R, 20%	0603	Std	Std
C3	100 pF, ceramic capacitor, 16 V, C0G, 10%	0603	Std	Std
C4	47 pF, ceramic capacitor, 16 V, X7R, 20%	0603	Std	Std
C5	0.22 μF, ceramic capacitor, 16 V, X7R, 20%	0603	Std	Std
C7	1.0 μF, ceramic capacitor, 16 V, X5R, 20%	0603	Std	Std
C8	10 μF, ceramic capacitor, 25 V, X7R, 20%	0805	C3225X7R1E106M	TDK
C9	0.1 μF, ceramic capacitor, 50 V, X7R, 20%	0603	Std	Std
C10	100 pF, ceramic capacitor, 16 V, X7R, 20%	0603	Std	Std
D1	Schottky diode, 3 A, 40 V	SMC	MBRS340T3	On Semi
L1	10 μH, inductor, SMT, 7.5 A, 12.4 mΩ	0.325 x 0.318 inch	RLF12560T-100M-7R5	TDK
Q1	MOSFET, N-channel, 40 V, 14 A, 9 mΩ	SO-8	Si4840DY	Vishay
R3	10 kΩ, chip resistor, 1/16 W, 5%	0603	Std	Std
R4	18.7 kΩ, chip resistor, 1/16 W, 1%	0603	Std	Std
R5	1.5 kΩ, chip resistor, 1/16 W, 1%	0603	Std	Std
R6	261 kΩ, chip resistor, 1/16 W, 1%	0603	Std	Std
R7	51.1 kΩ, chip resistor, 1/16 W, 1%	0603	Std	Std
R9	3.3 Ω, chip resistor, 1/16 W, 5%	0603	Std	Std
R10	1.0 kΩ, chip resistor, 1/16 W, 5%	0603	Std	Std
R11	10 mΩ, chip resistor, 1/2 W, 2%	1812	Std	Std
U1	IC, 4.5 V-52 V I/P, current mode boost controller	DGQ10	TPS40210QDGQRQ1	TI

DESIGN EXAMPLE 2

12-V Input, 700-mA LED Driver, Up to 35-V LED String

Application Schematic

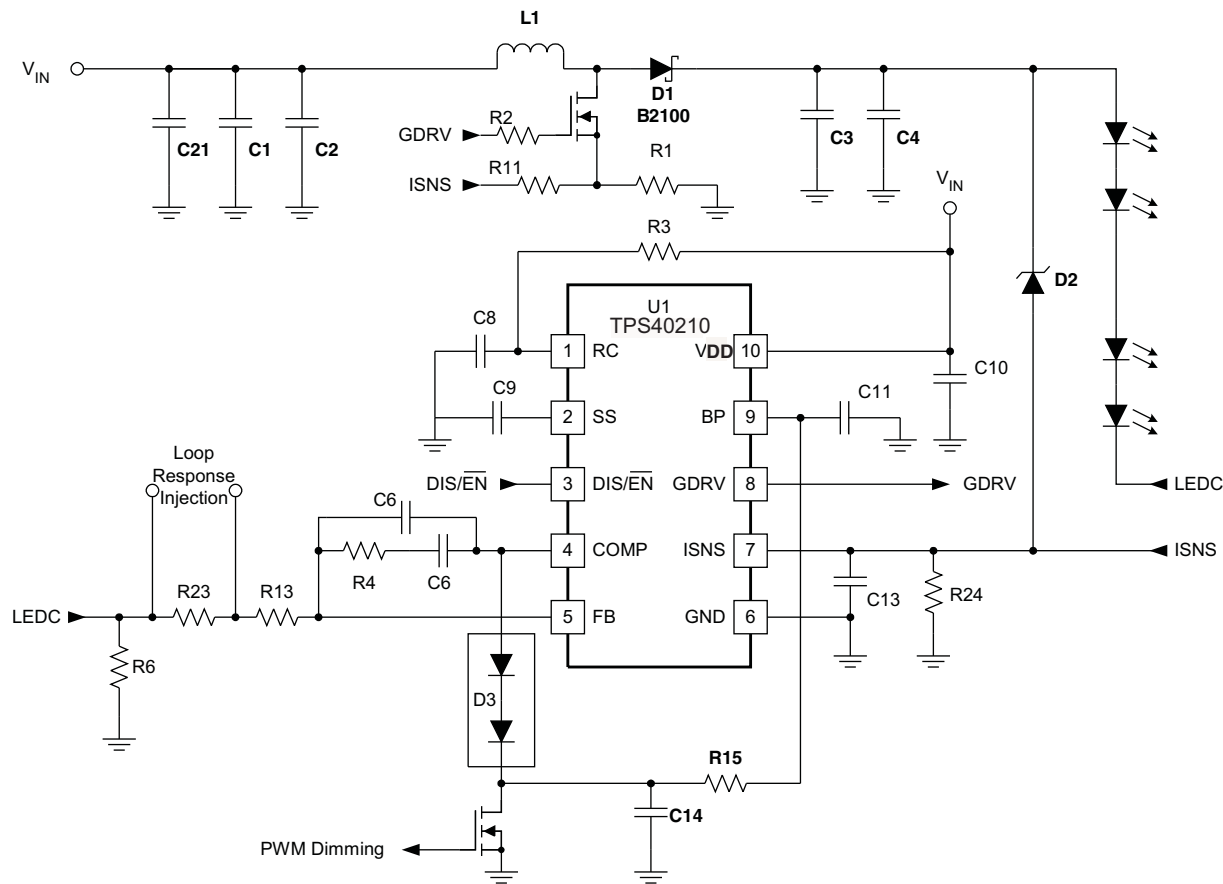

UDG-08015

Figure 37. 12-V Input, 700-mA LED Driver, Up to 35-V LED String

List of Materials

Table 4. List of Materials, Design Example 2

REFERENCE DESIGNATOR	TYPE	DESCRIPTION	SIZE	
C1, C2	Capacitor	10 μ F, 25 V	1206	
C3, C4		2.2 μ F, 100 V	1210	
C5		1 nF, NPO	0603	
C6		100 pF, NPO	0603	
C8		100 pF	0603	
C9		0.1 μ F	0603	
C10		0.1 μ F, 25 V	0805	
C11		1 μ F, 25 V	1206	
C13		220 pF	0603	
C14		10 nF, X7R	0603	
C21		330 μ F, 25 V electrolytic		
D1		Diode	B2100, Schottky, 100 V, 2 A	SMB
D2			BZT52C43	SOD-123
D3	MMBD7000		SOT-23	
L1	Inductor	Würth 7447709100, 10 μ H, 6 A	12 × 12 × 10 mm	
Q1	MOSFET	Si7850DP, 60 V, 31 m Ω	SO-8	
Q3		2N7002, 60 V, 0.1 A	SOT-23	
R1	Resistor	15 m Ω	2512	
R2		3.01 Ω	0805	
R3		402 k Ω	0603	
R4		14.3 k Ω	0603	
R6		0.36 Ω	2512	
R11		1 k Ω	0603	
R13		30.1 k Ω	0603	
R15		49.9 k Ω	0603	
R24		10 k Ω	0603	
R23		10 Ω	0603	
U1	Integrated circuit	TPS40211	DGQ-10	

PACKAGING INFORMATION

Orderable Device	Status (1)	Package Type	Package Drawing	Pins	Package Qty	Eco Plan (2)	Lead finish/ Ball material (6)	MSL Peak Temp (3)	Op Temp (°C)	Device Marking (4/5)	Samples
TPS40210SHKK	ACTIVE	CFP	HKK	10	25	RoHS & Green	AU	N / A for Pkg Type	-55 to 210	TPS40210S HKK	Samples
TPS40210SKGD1	ACTIVE	XCEPT	KGD	0	400	RoHS & Green	Call TI	N / A for Pkg Type	-55 to 210		Samples

(1) The marketing status values are defined as follows:

ACTIVE: Product device recommended for new designs.

LIFEBUY: TI has announced that the device will be discontinued, and a lifetime-buy period is in effect.

NRND: Not recommended for new designs. Device is in production to support existing customers, but TI does not recommend using this part in a new design.

PREVIEW: Device has been announced but is not in production. Samples may or may not be available.

OBSELETE: TI has discontinued the production of the device.

(2) **RoHS:** TI defines "RoHS" to mean semiconductor products that are compliant with the current EU RoHS requirements for all 10 RoHS substances, including the requirement that RoHS substance do not exceed 0.1% by weight in homogeneous materials. Where designed to be soldered at high temperatures, "RoHS" products are suitable for use in specified lead-free processes. TI may reference these types of products as "Pb-Free".

RoHS Exempt: TI defines "RoHS Exempt" to mean products that contain lead but are compliant with EU RoHS pursuant to a specific EU RoHS exemption.

Green: TI defines "Green" to mean the content of Chlorine (Cl) and Bromine (Br) based flame retardants meet JS709B low halogen requirements of <=1000ppm threshold. Antimony trioxide based flame retardants must also meet the <=1000ppm threshold requirement.

(3) MSL, Peak Temp. - The Moisture Sensitivity Level rating according to the JEDEC industry standard classifications, and peak solder temperature.

(4) There may be additional marking, which relates to the logo, the lot trace code information, or the environmental category on the device.

(5) Multiple Device Markings will be inside parentheses. Only one Device Marking contained in parentheses and separated by a "-" will appear on a device. If a line is indented then it is a continuation of the previous line and the two combined represent the entire Device Marking for that device.

(6) Lead finish/Ball material - Orderable Devices may have multiple material finish options. Finish options are separated by a vertical ruled line. Lead finish/Ball material values may wrap to two lines if the finish value exceeds the maximum column width.

Important Information and Disclaimer:The information provided on this page represents TI's knowledge and belief as of the date that it is provided. TI bases its knowledge and belief on information provided by third parties, and makes no representation or warranty as to the accuracy of such information. Efforts are underway to better integrate information from third parties. TI has taken and continues to take reasonable steps to provide representative and accurate information but may not have conducted destructive testing or chemical analysis on incoming materials and chemicals. TI and TI suppliers consider certain information to be proprietary, and thus CAS numbers and other limited information may not be available for release.

In no event shall TI's liability arising out of such information exceed the total purchase price of the TI part(s) at issue in this document sold by TI to Customer on an annual basis.

OTHER QUALIFIED VERSIONS OF TPS40210-HT :

- Catalog : [TPS40210](#)
- Automotive : [TPS40210-Q1](#)
- Enhanced Product : [TPS40210-EP](#)

NOTE: Qualified Version Definitions:

- Catalog - TI's standard catalog product
- Automotive - Q100 devices qualified for high-reliability automotive applications targeting zero defects
- Enhanced Product - Supports Defense, Aerospace and Medical Applications

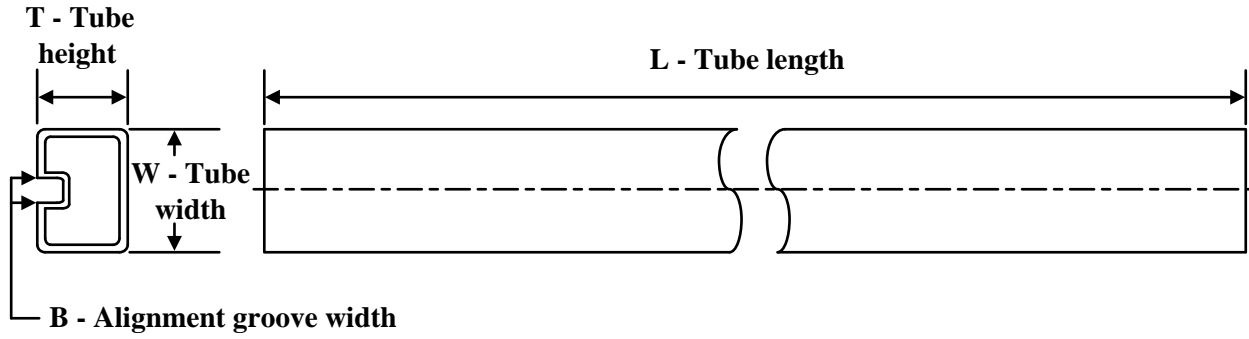
TUBE

*All dimensions are nominal

Device	Package Name	Package Type	Pins	SPQ	L (mm)	W (mm)	T (μm)	B (mm)
TPS40210SHKK	HKK	CFP	10	25	506.98	26.16	6220	NA

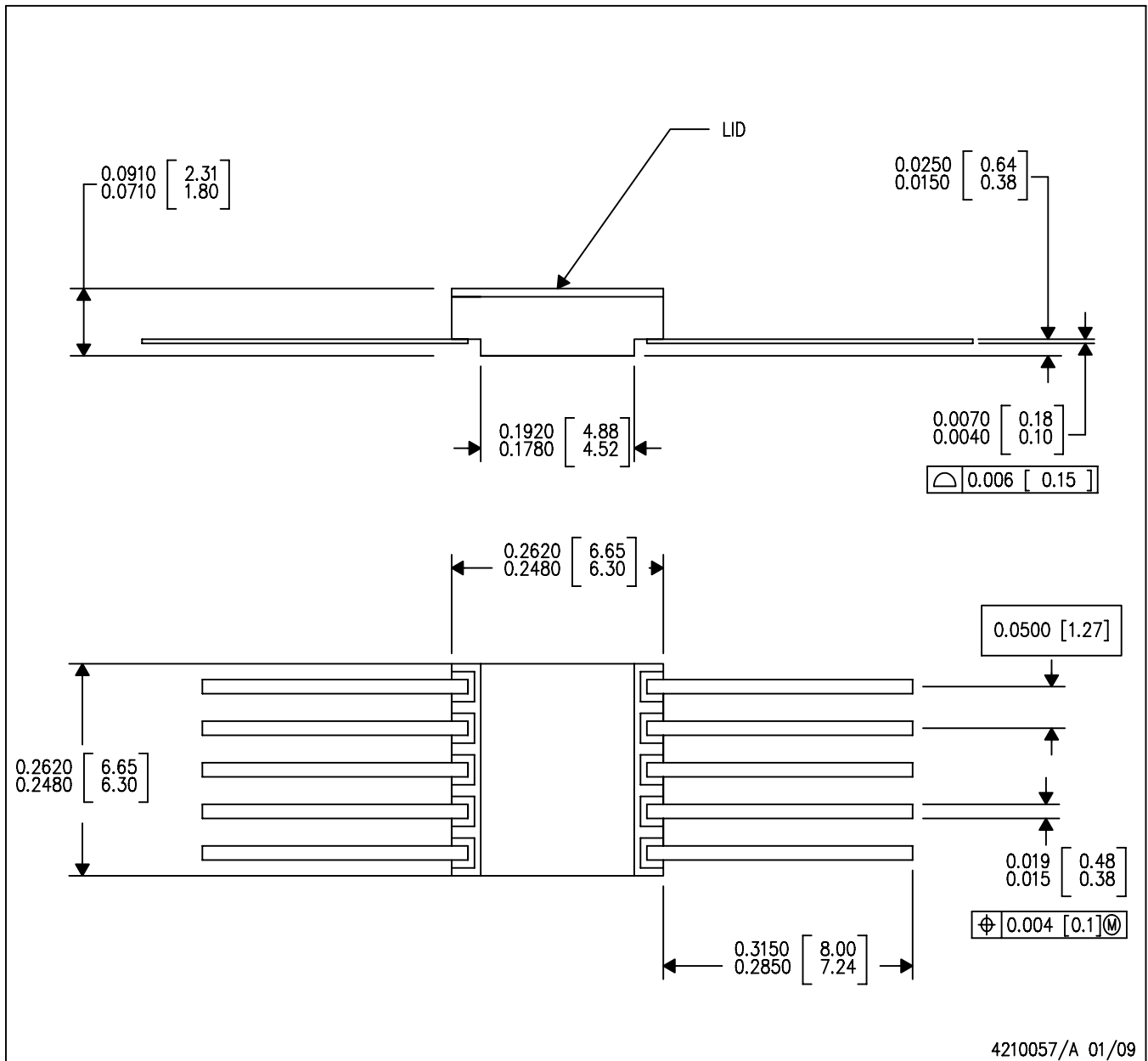

- NOTES:
- A. All linear dimensions are in inches (millimeters).
 - B. This drawing is subject to change without notice.
 - C. This drawing does not comply with Mil Std 1835. Do not use this package for compliant product.
 - D. The terminals will be gold plated.

IMPORTANT NOTICE AND DISCLAIMER

TI PROVIDES TECHNICAL AND RELIABILITY DATA (INCLUDING DATA SHEETS), DESIGN RESOURCES (INCLUDING REFERENCE DESIGNS), APPLICATION OR OTHER DESIGN ADVICE, WEB TOOLS, SAFETY INFORMATION, AND OTHER RESOURCES "AS IS" AND WITH ALL FAULTS, AND DISCLAIMS ALL WARRANTIES, EXPRESS AND IMPLIED, INCLUDING WITHOUT LIMITATION ANY IMPLIED WARRANTIES OF MERCHANTABILITY, FITNESS FOR A PARTICULAR PURPOSE OR NON-INFRINGEMENT OF THIRD PARTY INTELLECTUAL PROPERTY RIGHTS.

These resources are intended for skilled developers designing with TI products. You are solely responsible for (1) selecting the appropriate TI products for your application, (2) designing, validating and testing your application, and (3) ensuring your application meets applicable standards, and any other safety, security, regulatory or other requirements.

These resources are subject to change without notice. TI grants you permission to use these resources only for development of an application that uses the TI products described in the resource. Other reproduction and display of these resources is prohibited. No license is granted to any other TI intellectual property right or to any third party intellectual property right. TI disclaims responsibility for, and you will fully indemnify TI and its representatives against, any claims, damages, costs, losses, and liabilities arising out of your use of these resources.

TI's products are provided subject to [TI's Terms of Sale](#) or other applicable terms available either on ti.com or provided in conjunction with such TI products. TI's provision of these resources does not expand or otherwise alter TI's applicable warranties or warranty disclaimers for TI products.

TI objects to and rejects any additional or different terms you may have proposed.

Mailing Address: Texas Instruments, Post Office Box 655303, Dallas, Texas 75265
Copyright © 2022, Texas Instruments Incorporated

Looking for pricing, stock, or lifecycle information?

Click below to explore more details on WIN SOURCE:

 [View TPS40210SHKK on WIN SOURCE](#)

 [Texas Instruments](#) Information

Optimize Your Supply Chain with WIN SOURCE Solutions

-  Global Sourcing Solution
-  Obsolete Management
-  Cost Control Management
-  Shortage Management
-  Alternative Solution
-  Excess Inventory Management