



**THE DATASHEET OF
TPS62122DRVT**



TPS6212x 15-V, 75-mA Highly Efficient Buck Converter

1 Features

- Wide Input Voltage Range: 2 V to 15 V
- Up to 96% Efficiency
- Power Save Mode With 11- μ A Quiescent Current
- Output Current 75 mA
- Output Voltage Range: 1.2 V to 5.5 V
- Up to 800-kHz Switch Frequency
- Synchronous Converter, No External Rectifier
- Low Output Ripple Voltage
- 100% Duty Cycle for Lowest Dropout
- Small SOT 8-Pin (TPS62120) and 2-mm x 2-mm DFN 6-Pin (TPS62122) Package
- Internal Soft Start
- Power Good Open Drain Output (TPS62120)
- Open-Drain Output for Output Discharge (TPS62120)
- 2.5-V Rising and 1.85-V Falling UVLO Thresholds

2 Applications

- Low Power RF Applications
- Ultra Low Power Microprocessors
- Energy Harvesting
- Industrial Measuring

3 Description

The TPS6212x device is a highly efficient synchronous step-down DC-DC converter optimized for low-power applications. The device supports up to 75-mA output current and allows the use of tiny external inductors and capacitors.

The wide operating input voltage range of 2 V to 15 V supports energy harvesting, battery powered and as well 9-V or 12-V line powered applications.

With its advanced hysteretic control scheme, the converter provides power save mode operation. At light loads the converter operates in pulse frequency modulation (PFM) mode and transitions automatically in pulse width modulation (PWM) mode at higher load currents. The power save mode maintains high efficiency over the entire load current range. The hysteretic control scheme is optimized for low output ripple voltage in PFM mode in order to reduce output noise to a minimum. The device consumes only 10- μ A quiescent current from V_{IN} in PFM mode operation.

In shutdown mode, the device is turned off.

An open-drain power good output is available in the TPS62120 and indicates once the output voltage is in regulation.

The TPS62120 has an additional SGND pin which is connected to GND during shutdown mode. This output can be used to discharge the output capacitor.

The TPS6212x operates over an free air temperature range of -40°C to 85°C . The TPS62120 is available in a small 8-pin SOT-23 package and the TPS62122 in a 2 mm x 2 mm 6-pin DFN package.

Device Information⁽¹⁾

PART NUMBER	PACKAGE	BODY SIZE (NOM)
TPS62120	SOT-23 (8)	2.90 mm x 1.63 mm
TPS62122	SON (6)	2.00 mm x 2.00 mm

(1) For all available packages, see the orderable addendum at the end of the data sheet.

Typical Application Schematic

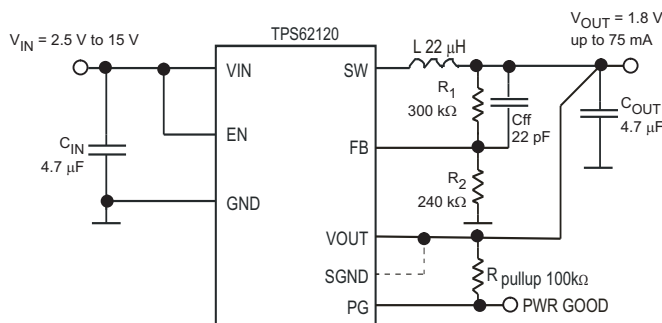

Efficiency vs Output Current

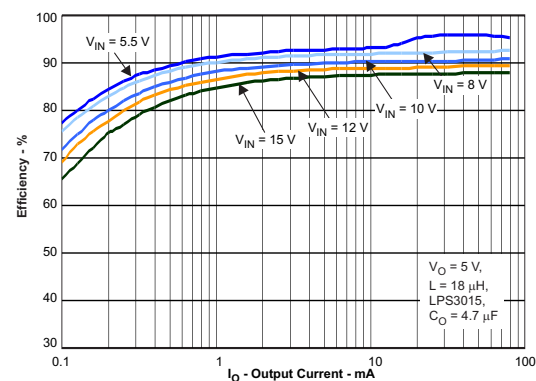

Table of Contents

1 Features	1	8.4 Device Functional Modes.....	10
2 Applications	1	9 Application and Implementation	12
3 Description	1	9.1 Application Information.....	12
4 Revision History	2	9.2 Typical Applications	12
5 Device Comparison Table	3	9.3 System Examples	20
6 Pin Configuration and Functions	3	10 Power Supply Recommendations	22
7 Specifications	4	11 Layout	22
7.1 Absolute Maximum Ratings	4	11.1 Layout Guidelines	22
7.2 ESD Ratings.....	4	11.2 Layout Examples.....	22
7.3 Recommended Operating Conditions.....	4	12 Device and Documentation Support	24
7.4 Thermal Information	5	12.1 Device Support.....	24
7.5 Electrical Characteristics.....	5	12.2 Related Links	24
7.6 Typical Characteristics.....	7	12.3 Community Resources.....	24
8 Detailed Description	8	12.4 Trademarks	24
8.1 Overview	8	12.5 Electrostatic Discharge Caution.....	24
8.2 Functional Block Diagram	8	12.6 Glossary	24
8.3 Feature Description.....	9	13 Mechanical, Packaging, and Orderable Information	24

4 Revision History

NOTE: Page numbers for previous revisions may differ from page numbers in the current version.

Changes from Original (July 2010) to Revision A

Page

<ul style="list-style-type: none"> Added <i>Pin Configuration and Functions</i> section, <i>Handling Rating</i> table, <i>Feature Description</i> section, <i>Device Functional Modes</i>, <i>Application and Implementation</i> section, <i>Power Supply Recommendations</i> section, <i>Layout</i> section, <i>Device and Documentation Support</i> section, and <i>Mechanical, Packaging, and Orderable Information</i> section 	1
---	---

5 Device Comparison Table

PART NUMBER	ACTIVE DISCHARGE SWITCH	POWER GOOD	V _{OUT}
TPS62120 ⁽¹⁾	yes	Open-Drain	adjustable
TPS62122 ⁽²⁾	no	no	adjustable

(1) The DCN package is available in tape on reel. Add R suffix to order quantities of 3000 parts per reel, T suffix for 250 parts per reel.

(2) The DRV package is available in tape on reel. Add R suffix to order quantities of 3000 parts per reel, T suffix for 250 parts per reel.

6 Pin Configuration and Functions

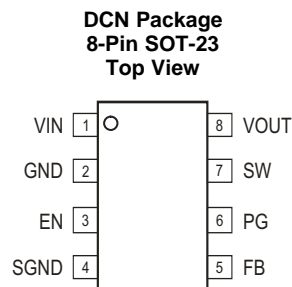
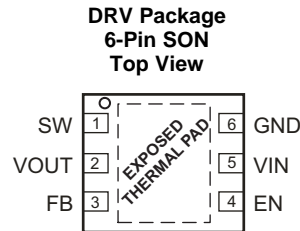

Pin Functions

PIN			I/O	DESCRIPTION
NAME	DFN	SOT-23		
EN	4	3	I	Pulling this pin to high activates the device. Low level shuts it down. This pin must be terminated.
FB	3	5	I	This is the feedback pin for the regulator. Connect external resistor-divider to this pin.
GND	6	2	PWR	GND supply pin.
PG	—	6	O	This pin is available in TPS62120 only. Open-drain power good output. Connect this terminal through a pullup resistor to a voltage rail up to 5.5 V or leave it open. This pin can sink 500 μ A.
SGND	—	4	I	This pin is available in TPS62120 only. Open-drain output which is turned on during shutdown mode (EN = 0) or VIN is below the UVLO threshold. The output connects the SGND pin to GND through an internal MOSFET with typical 370- Ω R _{DS(ON)} . When the device is enabled (EN = 1), this output is high impedance. To discharge the output capacitor during shutdown mode, connect this pin to VOUT (output capacitor) or leave it open.
SW	1	7	O	This is the switch pin and is connected to the internal MOSFET switches. Connect the inductor to this terminal. Do not tie this pin to VIN, VOUT or GND.
VIN	5	1	PWR	V _{IN} power supply pin.
VOUT	2	8	I	This pin must be connected to the output capacitor.
—	Exposed Thermal Pad	—	—	Exposed thermal pad available only in DRV package option. This pad must be connected to GND.

7 Specifications

7.1 Absolute Maximum Ratings

Over operating free-air temperature range (unless otherwise noted)⁽¹⁾

		MIN	MAX	UNIT	
V _I	Voltage at VIN ⁽²⁾	-0.3	17	V	
	Voltage at SW PIN	dynamically during switching t < 10 μs		17	V
		static DC	-0.3	6	
	Voltage at EN PIN ⁽²⁾	-0.3	VIN + 0.3, but ≤ 17	V	
	Voltage on FB Pin	-0.3	3.6	V	
Voltage at PG, VO _{UT} , SGND ⁽²⁾	-0.3	6	V		
I _{IN}	Current into PG pin		0.5	mA	
Maximum operating junction temperature, T _J		-40	125	°C	
Storage temperature, T _{stg}		-65	150	°C	

(1) Stresses beyond those listed under *Absolute Maximum Ratings* may cause permanent damage to the device. These are stress ratings only and functional operation of the device at these or any other conditions beyond those indicated under *Recommended Operating Conditions* is not implied. Exposure to absolute-maximum-rated conditions for extended periods may affect device reliability.

(2) All voltage values are with respect to network ground terminal GND.

7.2 ESD Ratings

		VALUE	UNIT
V _(ESD)	Electrostatic discharge	Human body model (HBM), per ANSI/ESDA/JEDEC JS-001 ⁽¹⁾	±2000
		Charged device model (CDM), per JEDEC specification JESD22-C101 ⁽²⁾	±1000

(1) JEDEC document JEP155 states that 500-V HBM allows safe manufacturing with a standard ESD control process.

(2) JEDEC document JEP157 states that 250-V CDM allows safe manufacturing with a standard ESD control process.

7.3 Recommended Operating Conditions

		MIN	NOM	MAX	UNIT
Supply voltage VIN, device in operation		2		15	V
Output current capability	V _{IN} = 2 V, V _{OUT} = 1.8 V, DCR _L = 0.7 Ω	25			mA
	V _{IN} ≥ 2.5 V, V _{OUT} = 1.8 V, DCR _L = 0.7 Ω	75			
Effective inductance		10	22	33	μH
Effective output capacitance		1.0	2	33	μF
Output voltage		1.2		5.5	V
Operating ambient temperature T _A ⁽¹⁾ , (unless otherwise noted)		-40		85	°C
Operating junction temperature, T _J		-40		125	°C

(1) In applications where high power dissipation and/or poor package thermal resistance is present, the maximum ambient temperature may have to be derated. Maximum ambient temperature (T_{A(max)}) is dependent on the maximum operating junction temperature (T_{J(max)}), the maximum power dissipation of the device in the application (P_{D(max)}), and the junction-to-ambient thermal resistance of the part/package in the application (R_{θJA}), as given by the following equation: T_{A(max)} = T_{J(max)} - (R_{θJA} × P_{D(max)}).

7.4 Thermal Information

THERMAL METRIC ⁽¹⁾		TPS62120	TPS62122	UNIT
		DCN [SOT-23]	DRV [DFN]	
		8 PINS	6 PINS	
R _{θJA}	Junction-to-ambient thermal resistance	259.7	114.4	°C/W
R _{θJC(top)}	Junction-to-case(top) thermal resistance	114.1	73.7	°C/W
R _{θJB}	Junction-to-board thermal resistance	185.8	201.9	°C/W
ψ _{JT}	Junction-to-top characterization parameter	21.6	0.8	°C/W
ψ _{JB}	Junction-to-board characterization parameter	121.6	94.9	°C/W
R _{θJC(bot)}	Junction-to-case(bottom) thermal resistance	n/a	122.7	°C/W

(1) For more information about traditional and new thermal metrics, see the *Semiconductor and IC Package Thermal Metrics* application report, [SPRA953](#)

7.5 Electrical Characteristics

V_{IN} = 8 V, V_{OUT} = 1.8 V, EN = V_{IN}, T_J = –40°C to 85°C, typical values are at T_J = 25°C (unless otherwise noted), C_{IN} = 4.7 μF, L = 22 μH, C_{OUT} = 4.7 μF

PARAMETER		TEST CONDITIONS	MIN	TYP	MAX	UNIT	
SUPPLY							
V _{IN}	Input voltage range ⁽¹⁾	Device operating	2		15	V	
I _Q	Quiescent current	I _{OUT} = 0 mA, device not switching, EN = V _{IN} , regulator sleeps		11	18	μA	
		I _{OUT} = 0 mA, device switching, V _{IN} = 8 V, V _{OUT} = 1.8 V		13			
I _{Active}	Active mode current consumption	V _{IN} = 5.5 V = V _{OUT} , T _J = 25°C, high-side MOSFET switch fully turned on		240	275	μA	
I _{SD}	Shutdown current	EN = GND, V _{OUT} = SW = 0 V, V _{IN} = 3.6 V ⁽²⁾		0.3	1.2	μA	
V _{UVLO}	Undervoltage lockout threshold	Falling V _{IN}		1.85	1.95	V	
		Rising V _{IN}		2.5	2.61		
ENABLE, THRESHOLD							
V _{IH TH}	Threshold for detecting high EN	2 V ≤ V _{IN} ≤ 15 V, rising edge		0.8	1.1	V	
V _{IL TH HYS}	Threshold for detecting low EN	2 V ≤ V _{IN} ≤ 15 V, falling edge		0.4	0.6	V	
I _{IN}	Input bias current, EN	EN = GND or V _{IN}		0	50	nA	
POWER SWITCH							
R _{DS(ON)}	High-side MOSFET ON-resistance	V _{IN} = 3.6 V		2.3	3.4	Ω	
		V _{IN} = 8 V		1.75	2.5		
	Low-side MOSFET ON-resistance	V _{IN} = 3.6 V		1.3	2.5		
		V _{IN} = 8 V		1.2	1.75		
I _{LIMF}	Forward current limit MOSFET high-side	V _{IN} = 8 V, open loop		200	250	400	mA
T _{SD}	Thermal shutdown	Increasing junction temperature		150		°C	
	Thermal shutdown hysteresis	Decreasing junction temperature		20		°C	
REGULATOR							
t _{ONmin}	Minimum ON time	V _{IN} = 3.6 V, V _{OUT} = 1.8 V		700		ns	
t _{OFFmin}	Minimum OFF time	V _{IN} = 3.6 V, V _{OUT} = 1.8 V		60		ns	
V _{REF}	Internal reference voltage			0.8		V	
V _{FB}	Feedback FB voltage comparator threshold	Referred to 0.8-V internal reference		–2.5%	0%	2.5%	
	Feedback FB voltage line regulation	I _{OUT} = 50 mA ⁽³⁾		0.04		%/V	
I _{IN}	Input bias current FB	V _{FB} = 0.8 V		0	50	nA	

(1) The typical required supply voltage for startup is 2.5 V. The part is functional down to the falling UVLO (undervoltage lockout) threshold.

(2) Shutdown current into VIN pin, includes internal leakage.

(3) V_{OUT} + 1 V ≤ V_{IN}; V_{OUT} ≤ 5.5 V

Electrical Characteristics (continued)

$V_{IN} = 8\text{ V}$, $V_{OUT} = 1.8\text{ V}$, $EN = V_{IN}$, $T_J = -40^\circ\text{C}$ to 85°C , typical values are at $T_J = 25^\circ\text{C}$ (unless otherwise noted), $C_{IN} = 4.7\text{ }\mu\text{F}$, $L = 22\text{ }\mu\text{H}$, $C_{OUT} = 4.7\text{ }\mu\text{F}$

PARAMETER		TEST CONDITIONS	MIN	TYP	MAX	UNIT
t_{Start}	Regulator start-up time	Time from active EN to device starts switching, $V_{IN} = 2.6\text{ V}$	50	150		μs
t_{Ramp}	Output voltage ramp time	Time to ramp up $V_{OUT} = 1.8\text{ V}$, no load ⁽⁴⁾	120	300		
I_{LK_SW}	Leakage current into SW pin	$V_{OUT} = V_{IN} = V_{SW} = 1.8\text{ V}$, $EN = \text{GND}$, device in shutdown mode	1	1.5		μA
POWER GOOD OUTPUT (TPS62120)						
V_{THPG}	Power good threshold voltage	Rising V_{FB} feedback voltage	93%	95%	97%	
		Falling V_{FB} feedback voltage	87%	90%	93%	
V_{OL}	Output low voltage	Current into PG pin $I = 500\text{ }\mu\text{A}$, $V_{OUT} > 1.5\text{ V}$			165	mV
		Current into PG pin $I = 100\text{ }\mu\text{A}$, $1.2\text{ V} < V_{OUT} < 1.5\text{ V}$			50	
V_H	Output high voltage	Open drain output, external pull up resistor			5.5	V
I_{LKG}	Leakage current into PG pin	$V_{(PG)} = 1.8\text{ V}$, $EN = \text{high}$, $FB = 0.85\text{ V}$	0	50		nA
	Leakage into VOUT pin	$V_{(OUT)} = 1.8\text{ V}$	0	50		nA
T_{PGDL}	Internal power good comparator delay time	$V_{OUT} = 1.8\text{ V}$	2	5		μs
SGND OPEN DRAIN OUTPUT (TPS62120)						
$R_{DS(ON)}$	NMOS drain source resistance	$SGND = 1.8\text{ V}$, $V_{IN} = 2\text{ V}$	370			Ω
I_{LKG}	Leakage current into SGND pin	$EN = V_{IN}$, $SGND = 1.8\text{ V}$	0	50		nA

(4) Maximum value not production tested.

7.6 Typical Characteristics

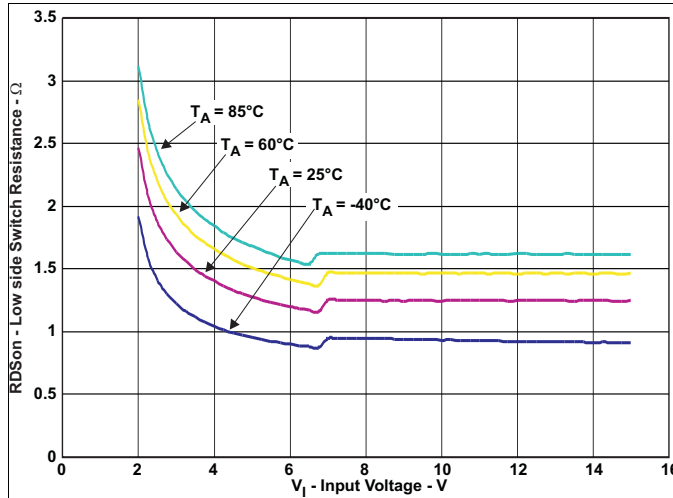

Figure 1. Low-Side Switch Resistance $R_{DS(ON)}$ vs V_{IN}

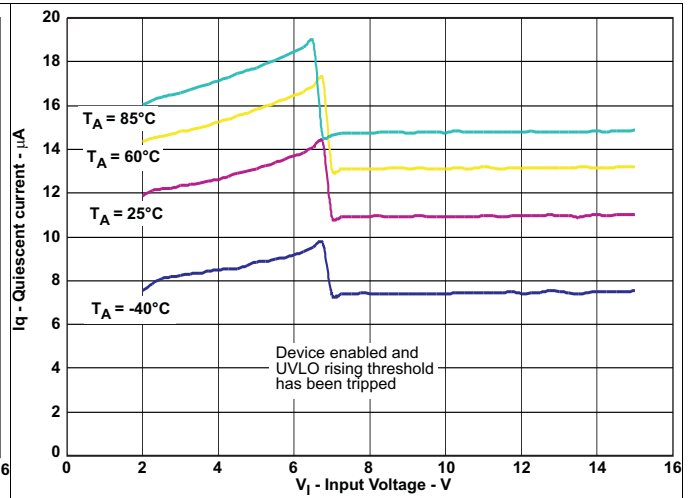

Figure 2. Quiescent Current vs V_{IN}

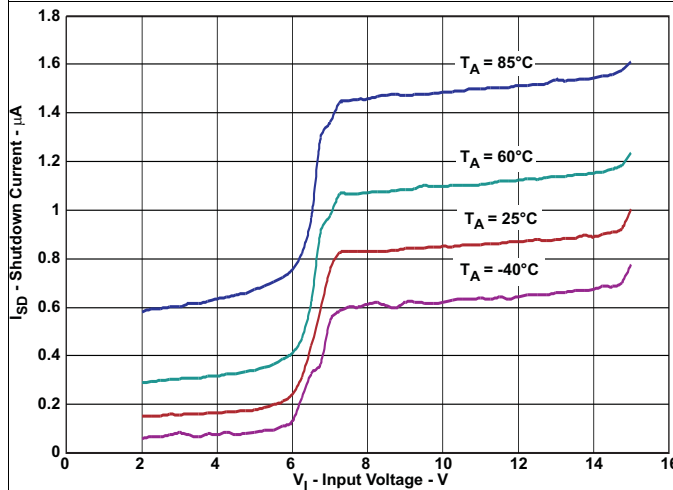

Figure 3. Shutdown Current vs V_{IN}

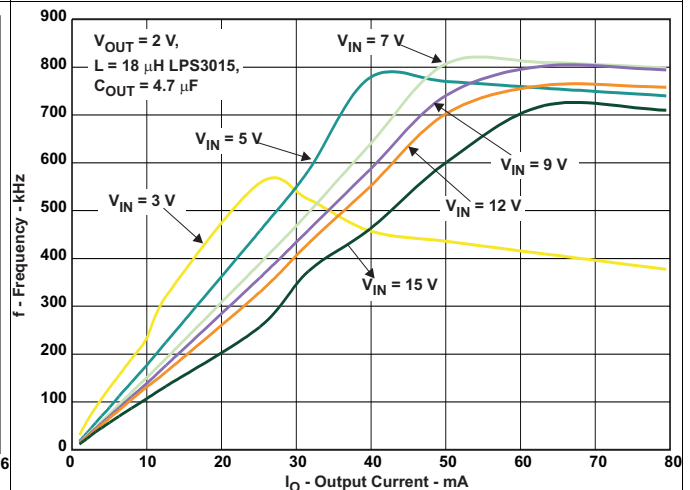

Figure 4. Switch Frequency vs Output Current I_{OUT} ($V_{OUT} = 2 V$)

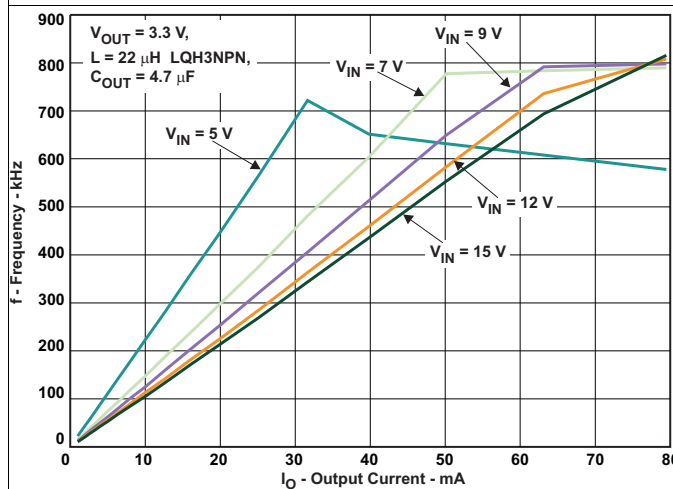

Figure 5. Switch Frequency vs Output Current I_{OUT} ($V_{OUT} = 3.3 V$)

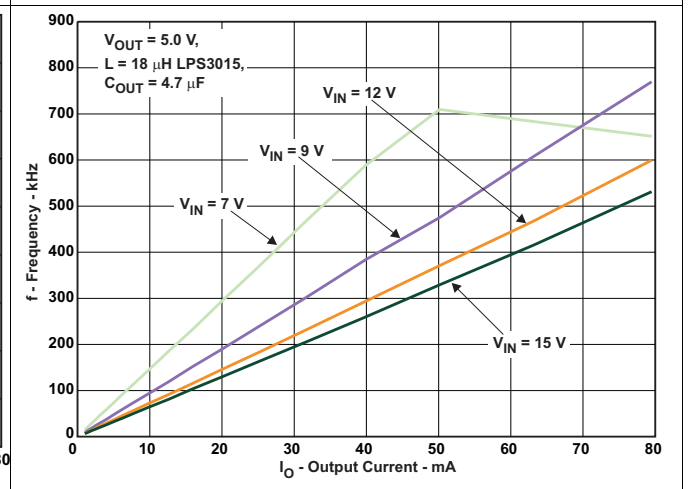

Figure 6. Switch Frequency vs Output Current I_{OUT} ($V_{OUT} = 5 V$)

8 Detailed Description

8.1 Overview

The TPS6212x synchronous step-down converter family uses an unique hysteretic PFM/PWM controller scheme which enables switching frequencies of up to 800 kHz, excellent transient response and AC load regulation at operation with small output capacitors.

At high load currents the converter operates in quasi fixed frequency pulse width modulation (PWM) mode operation and at light loads in pulse frequency modulation (PFM) mode to maintain highest efficiency over the full load current range. In PFM mode, the device generates a single switch pulse to ramp the inductor current and charge the output capacitor, followed by a sleep period where most of the internal circuits are shutdown to achieve a quiescent current of typically 10 μ A. During this time, the load current is supported by the output capacitor. The duration of the sleep period depends on the load current and the inductor peak current.

A significant advantage of TPS6212x compared to other hysteretic controller topologies is its excellent DC and AC load regulation capability in combination with low output voltage ripple over the entire load range which makes this part well suited for audio and RF applications.

8.2 Functional Block Diagram

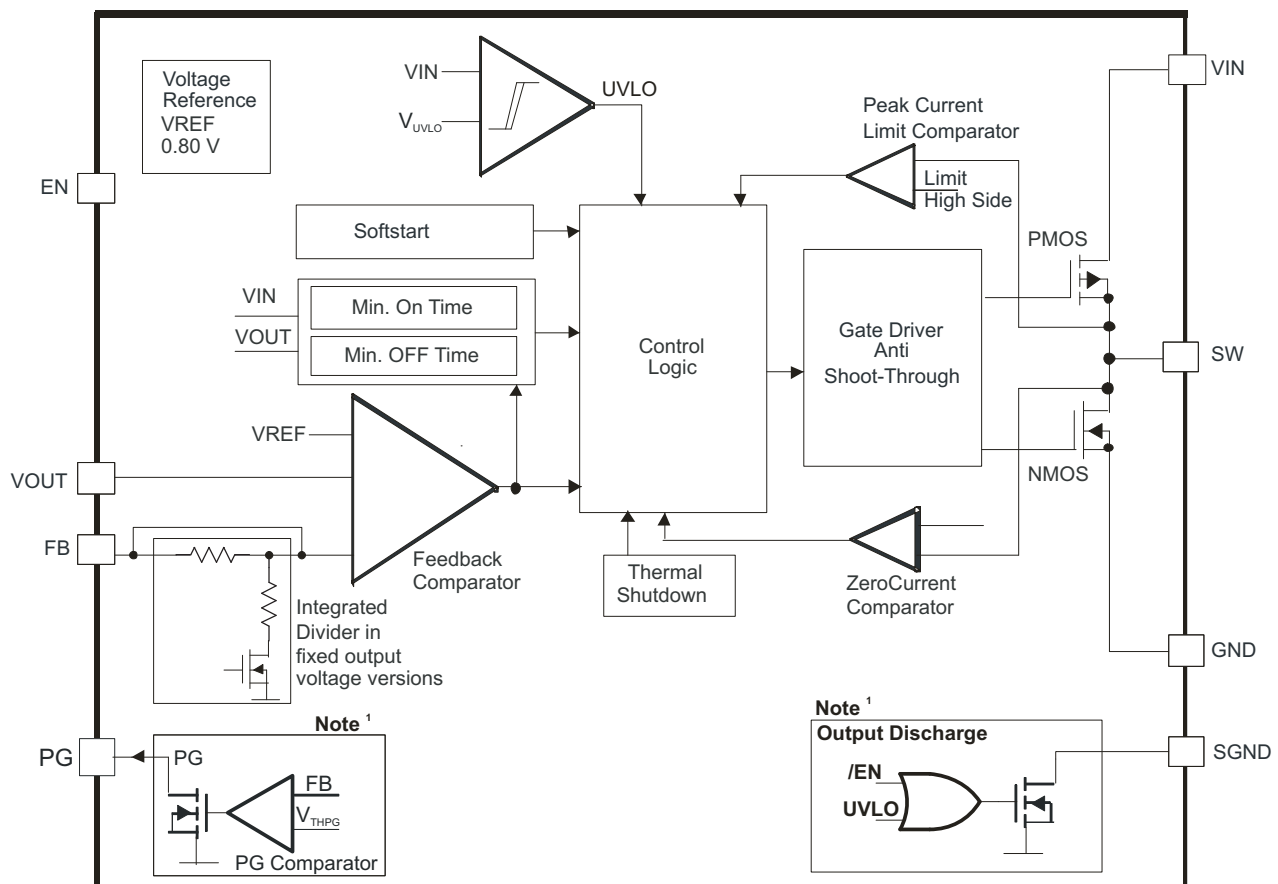

(1) Function available in TPS62120

8.3 Feature Description

8.3.1 Undervoltage Lockout

The undervoltage lockout circuit prevents the device from misoperation at low input voltages. The circuit prevents the converter from turning on the high-side MOSFET switch or low-side MOSFET under undefined conditions. The UVLO threshold is set to 2.5 V typical for rising V_{IN} and 1.85 V typical for falling V_{IN} . The hysteresis between rising and falling UVLO threshold ensures proper start-up even with high-impedance sources. Fully functional operation is permitted for an input voltage down to the falling UVLO threshold level. The converter starts operation again once the input voltage trips the rising UVLO threshold level.

8.3.2 Enable and Shutdown

The device starts operation when EN pin is set high and the input voltage V_{IN} has tripped the UVLO threshold for rising V_{IN} . It starts switching after the regulator start-up time t_{Start} of typically 50 μ s has expired and enters the soft start as previously described. For proper operation, the EN pin must be terminated and must not be left floating.

EN pin low forces the device into shutdown, with a shutdown quiescent current of typically 0.3 μ A.

In this mode, the high-side and low-side MOSFET switches as well as the entire internal-control circuitry are switched off.

In TPS62120 the internal N-MOSFET at pin SGND is activated and connects SGND to GND.

8.3.3 Power Good Output

The Power Good Output is an open-drain output available in TPS62120. The circuit is active once the device is enabled. It is driven by an internal comparator connected to the FB voltage and internal reference. The PG output provides a high level (open-drain high impedance) once the feedback voltage exceeds typical 95% of its nominal value. The PG output is driven to low level once the feedback voltage falls below typical 90% of its nominal value. The PG output is high (high impedance) with an internal delay of typically 2 μ s. A pullup resistor is needed to generate a high level and limit the current into the PG pin to 0.5 mA. The PG pin can be connected through pullup resistors to a voltage up to 5.5 V.

The PG output is pulled low if the device is enabled but the input voltage is below the UVLO threshold or the device is turned into shutdown mode.

8.3.4 SGND Open-Drain Output

This is an NMOS open-drain output with a typical $R_{DS(ON)}$ of 370 Ω and can be used to discharge the output capacitor. The internal NMOS connects SGND pin to GND once the device is in shutdown mode or V_{IN} falls below the UVLO threshold during operation. SGND becomes high impedance once the device is enabled and V_{IN} is above the UVLO threshold. If SGND is connected to the output, the output capacitor is discharged through SGND.

8.3.5 Thermal Shutdown

As soon as the junction temperature, T_J , exceeds 150°C (typical) the device goes into thermal shutdown. In this mode, the high-side and low-side MOSFETs are turned off. The device continues its operation when the junction temperature falls below the thermal shutdown hysteresis.

8.4 Device Functional Modes

8.4.1 Soft Start

The TPS6212x has an internal soft-start circuit which controls the ramp-up of the output voltage and limits the inrush current during start-up. This limits input voltage drop when a battery or a high-impedance power source is connected to the input of the converter.

The soft-start system generates a monotonic ramp up of the output voltage with a ramp of typically 15 mV/μs and reaches an output voltage of 1.8 V in typically 170 μs after EN pin was pulled high. The TPS6212x is able to start into a prebiased output capacitor. The converter starts with the applied bias voltage and ramps the output voltage to its nominal value.

During start-up the device can provide an output current of half of the high-side MOSFET switch current limit I_{LIMF} . Large output capacitors and high load currents may exceed the current capability of the device during start-up. In this case the start-up ramp of the output voltage will be slower.

8.4.2 Main Control Loop

The feedback comparator monitors the voltage on the FB pin and compares it to an internal 800-mV reference voltage.

The feedback comparator trips once the FB voltage falls below the reference voltage. A switching pulse is initiated and the high-side MOSFET switch is turned on. The switch remains turned on at least for the minimum on-time T_{ONmin} of typical 700 ns until the feedback voltage is above the reference voltage or the inductor current reaches the high-side MOSFET switch current limit I_{LIMF} . Once the high-side MOSFET switch turns off, the low-side MOSFET switch is turned on and the inductor current ramps down. The switch is turned on at least for the minimum off time T_{OFFmin} of typically 60 ns. The low-side MOSFET switch stays turned on until the FB voltage falls below the internal reference and trips the FB comparator again. This will turn on the high-side MOSFET switch for a new switching cycle.

If the feedback voltage stays above the internal reference the low-side MOSFET switch is turned on until the zero current comparator trips and indicates that the inductor current has ramped down to zero. In this case, the load current is much lower than the average inductor current provided during one switching cycle. The regulator turns the low-side and high-side MOSFET switches off (high impedance state) and enters a sleep cycle with reduced quiescent current of typically 10 μA until the output voltage falls below the internal reference voltage and the feedback comparator trips again. This is called PFM mode and the switching frequency depends on the load current, input voltage, output voltage and the external inductor value.

Once the high-side switch current limit comparator has tripped its threshold of I_{LIMF} , the high-side MOSFET switch is turned off and the low-side MOSFET switch is turned on until the inductor current has ramped down to zero.

The minimum on time T_{ONmin} for a single pulse can be estimated to:

$$T_{ON} = \frac{V_{OUT}}{V_{IN}} \times 1.3 \mu s \quad (1)$$

Therefore the peak inductor current in PFM mode is approximately:

$$I_{LPMpeak} = \frac{(V_{IN} - V_{OUT})}{L} \times T_{ON} \quad (2)$$

The transition from PFM mode to PWM mode operation and back occurs at a load current of approximately $0.5 \times I_{LPMpeak}$.

With:

- T_{ON} = High-side MOSFET switch on time [μs]
- V_{IN} = Input voltage [V]
- V_{OUT} = Output voltage [V]
- L = Inductance [μH]
- $I_{LPMpeak}$ = PFM inductor peak current [mA]

The maximum switch frequency can be estimated to:

Device Functional Modes (continued)

$$f_{\text{SWmax}} \approx \frac{1}{1.3 \mu\text{s}} = 770 \text{ kHz} \quad (3)$$

8.4.3 100% Duty Cycle Low-Dropout Operation

The device will increase the on time of the high-side MOSFET switch once the input voltage comes close to the output voltage in order to keep the output voltage in regulation. This will reduce the switch frequency.

With further decreasing input voltage V_{IN} the high-side MOSFET switch is turned on completely. In this case the converter provides a low input-to-output voltage difference. This is particularly useful in applications with widely variable supply voltage to achieve longest operation time by taking full advantage of the whole supply voltage span.

The minimum input voltage to maintain regulation depends on the load current and output voltage, and can be calculated as:

$$V_{\text{in}_{\text{min}}} = V_{\text{out}_{\text{max}}} + I_{\text{out}_{\text{max}}} \times (R_{\text{DS(ON)max}} + R_{\text{L}})$$

where

- I_{OUTmax} = maximum output current
 - $R_{\text{DS(ON)max}}$ = maximum P-channel switch $R_{\text{DS(ON)}}$
 - R_{L} = DC resistance of the inductor
 - V_{OUTmax} = nominal output voltage plus maximum output voltage tolerance
- (4)

8.4.4 Short-Circuit Protection

The TPS6212x integrates a high-side MOSFET switch current limit I_{LIMF} to protect the device against short circuit. The current in the high-side MOSFET switch is monitored by current limit comparator and once the current reaches the limit of I_{LIMF} , the high-side MOSFET switch is turned off and the low-side MOSFET switch is turned on to ramp down the inductor current. The high-side MOSFET switch is turned on again once the zero current comparator trips and the inductor current has become zero. In this case, the output current is limited to half of the high-side MOSFET switch current limit $0.5 \times I_{\text{LIMF}}$.

9 Application and Implementation

NOTE

Information in the following applications sections is not part of the TI component specification, and TI does not warrant its accuracy or completeness. TI's customers are responsible for determining suitability of components for their purposes. Customers should validate and test their design implementation to confirm system functionality.

9.1 Application Information

The TPS6212x device is a highly efficient synchronous step-down DC-DC converter optimized for low-power applications. With its wide input voltage range, the device also fits for energy harvesting applications to convert electrical power from electromagnetic transducers.

9.2 Typical Applications

9.2.1 TPS62120 With Open-Drain Output

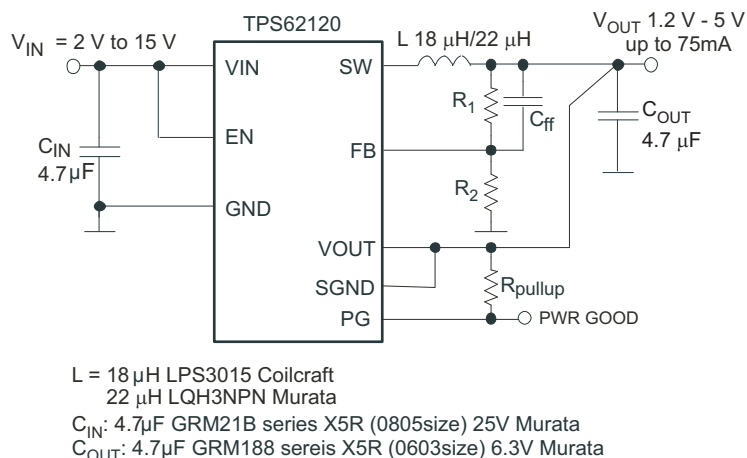

Figure 7. Standard Circuit for TPS62120 With Open-Drain Output

9.2.1.1 Design Requirements

The device operates over an input voltage range from 2 V to 15V. The output voltage is adjustable using an external feedback divider network.

The design guideline provides a component selection to operate the device within the [Recommended Operating Conditions](#).

9.2.1.2 Detailed Design Procedure

9.2.1.2.1 Output Voltage Setting

The output voltage can be calculated to:

$$V_{OUT} = V_{REF} \times \left(1 + \frac{R_1}{R_2}\right) \text{ with an internal reference voltage } V_{REF} \text{ typical } 0.8\text{ V}$$

$$R_1 = \left(\frac{V_{OUT}}{V_{REF}} - 1\right) \times R_2 \tag{5}$$

To minimize the current through the feedback divider network, R_2 should be within the range of 82 k Ω to 360 k Ω . The sum of R_1 and R_2 should not exceed approximately 1 M Ω , to keep the network robust against noise. An external feedforward capacitor C_{ff} is required for optimum regulation performance. R_1 and C_{ff} places a zero in the feedback loop.

Typical Applications (continued)

$$f_z = \frac{1}{2 \times \pi \times R_1 \times C_{ff}} = 25 \text{ kHz} \quad (6)$$

The value for C_{ff} can be calculated as:

$$C_{ff} = \frac{1}{2 \times \pi \times R_1 \times 25 \text{ kHz}} \quad (7)$$

Table 1 shows a selection of suggested values for the feedback divider network for most common output voltages.

Table 1. Suggested Values for Feedback Divider Network

VOLTAGE SETTING (V)	3.06	3.29	2.00	1.80	1.20	5.00
R_1 [k Ω]	510	560	360	300	180	430
R_2 [k Ω]	180	180	240	240	360	82
C_{ff} [pF]	15	22	22	22	27	15

9.2.1.2.2 Output Filter Design (Inductor and Output Capacitor)

The TPS6212x operates with effective inductance values in the range of 10 μH to 33 μH and with effective output capacitance in the range of 1 μF to 33 μF . The device is optimized to operate for an output filter of $L = 22 \mu\text{H}$ and $C_{OUT} = 4.7 \mu\text{F}$. Larger or smaller inductor and capacitor values can be used to optimize the performance of the device for specific operation conditions. For more details, see [Checking Loop Stability](#).

9.2.1.2.3 Inductor Selection

The inductor value affects its peak-to-peak ripple current, the PWM-to-PFM transition point, the output voltage ripple, and the efficiency. The selected inductor has to be rated for its DC resistance and saturation current. The inductor ripple current (ΔI_L) decreases with higher inductance and increases with higher V_{IN} or V_{OUT} and can be estimated according to [Equation 8](#).

[Equation 9](#) calculates the maximum inductor current under static load conditions. The saturation current of the inductor should be rated higher than the maximum inductor current as calculated with [Equation 9](#). This is recommended because during heavy load transient the inductor current will rise above the calculated value. A more conservative way is to select the inductor saturation current according to the high-side MOSFET switch current limit I_{LIMF} .

$$\Delta I_L = \frac{(V_{IN} - V_{OUT})}{L} \times T_{ON} \quad (8)$$

$$I_{Lmax} = I_{outmax} + \frac{\Delta I_L}{2}$$

where

- T_{ON} = See [Equation 1](#)
 - L = Inductor value
 - ΔI_L = Peak-to-peak inductor ripple current
 - I_{Lmax} = Maximum inductor current
- (9)

In DC-DC converter applications, the efficiency is essentially affected by the inductor AC resistance (that is, quality factor) and by the inductor DCR value. To achieve high efficiency operation, care should be taken in selecting inductors featuring a quality factor above 25 at the switching frequency. Increasing the inductor value produces lower RMS currents, but degrades transient response. For a given physical inductor size, increased inductance usually results in an inductor with lower saturation current.

The total losses of the coil consist of both the losses in the DC resistance ($R_{(DC)}$) and the following frequency-dependent components:

- the losses in the core material (magnetic hysteresis loss, especially at high switching frequencies)
- additional losses in the conductor from the skin effect (current displacement at high frequencies)
- magnetic field losses of the neighboring windings (proximity effect)

- radiation losses

The following inductor series from different suppliers have been used with the TPS6212x converters.

Table 2. List of Inductors

INDUCTANCE (μH)	DIMENSIONS (mm^3)	INDUCTOR TYPE	SUPPLIER
22	3 × 3 × 1.5	LQH3NPN	Murata
18/22	3 × 3 × 1.5	LPS3015	Coilcraft

9.2.1.2.4 Output Capacitor Selection

The unique hysteretic PFM/PWM control scheme of the TPS6212x allows the use of ceramic capacitors. Ceramic capacitors with low ESR values have the lowest output voltage ripple and are recommended. The output capacitor requires either an X7R or X5R dielectric. Y5V and Z5U dielectric capacitors, aside from their wide variation in capacitance over temperature, become resistive at high frequencies.

At light load currents the converter operates in power save mode and the output voltage ripple is dependent on the output capacitor value and the PFM peak inductor current. Higher output capacitor values minimize the voltage ripple in PFM mode and tighten DC output accuracy in PFM mode.

9.2.1.2.5 Input Capacitor Selection

Because of the nature of the buck converter having a pulsating input current, a low ESR input capacitor is required for best input voltage filtering and minimizing the interference with other circuits caused by high input voltage spikes. For most applications a 4.7 μF to 10 μF ceramic capacitor is recommended. The voltage rating and DC bias characteristic of ceramic capacitors need to be considered. The input capacitor can be increased without any limit for better input voltage filtering.

For specific applications like energy harvesting a tantalum or tantalum polymer capacitor can be used to achieve a specific DC-DC converter input capacitance. Tantalum capacitors provide much better DC bias performance compared to ceramic capacitors. In this case a 1- μF or 2.2- μF ceramic capacitor should be used in parallel to provide low ESR.

Take care when using only small ceramic input capacitors. When a ceramic capacitor is used at the input and the power is being supplied through long wires, such as from a wall adapter, a load step at the output or V_{IN} step on the input can induce large ringing at the VIN pin. This ringing can couple to the output and be mistaken as loop instability or could even damage the part by exceeding the maximum ratings.

Table 3 shows a list of input and output capacitors.

Table 3. List of Capacitors

CAPACITANCE (μF)	SIZE	CAPACITOR TYPE	USAGE	SUPPLIER
4.7	0603	GRM188 series 6.3 V X5R	C_{OUT}	Murata
2.2	0603	GRM188 series 6.3 V X5R	C_{OUT}	Murata
4.7	0805	GRM21Bseries 25 V X5R	C_{IN}	Murata
10	0805	GRM21Bseries 16 V X5R	C_{IN}	Murata
8.2	B2 (3.5 × 2.8 × 1.9)	20TQC8R2M (20 V)	C_{IN}	Sanyo

9.2.1.2.6 Checking Loop Stability

The first step of circuit and stability evaluation is to look from a steady-state perspective at the following signals:

- Switching node, SW
- Inductor current, I_L
- Output ripple voltage, $V_{\text{O(AC)}}$

These are the basic signals that need to be measured when evaluating a switching converter. When the switching waveform shows large duty cycle jitter or the output voltage or inductor current shows oscillations, the regulation loop may be unstable. This is often a result of board layout and/or L-C combination.

As a next step in the evaluation of the regulation loop, the load transient response is tested. During application of the load transient and the turn on of the high-side MOSFET switch, the output capacitor must supply all of the current required by the load. V_{OUT} immediately shifts by an amount equal to $\Delta I_{(LOAD)} \times ESR$, where ESR is the effective series resistance of C_{OUT} . $\Delta I_{(LOAD)}$ begins to charge or discharge C_{OUT} generating a feedback error signal used by the regulator to return V_{OUT} to its steady-state value. The results are most easily interpreted when the device operates in PWM mode.

During this recovery time, V_{OUT} can be monitored for settling time, overshoot or ringing that helps judge the converter's stability. Without any ringing, the loop has usually more than 45° of phase margin. Because the damping factor of the circuitry is directly related to several resistive parameters (for example, MOSFET $R_{DS(on)}$) which are temperature dependent, the loop stability analysis should be done over the input voltage range, load current range, and temperature range

9.2.1.3 Application Curves

All graphs have been generated using the circuit as shown in Figure 7 unless otherwise noted.

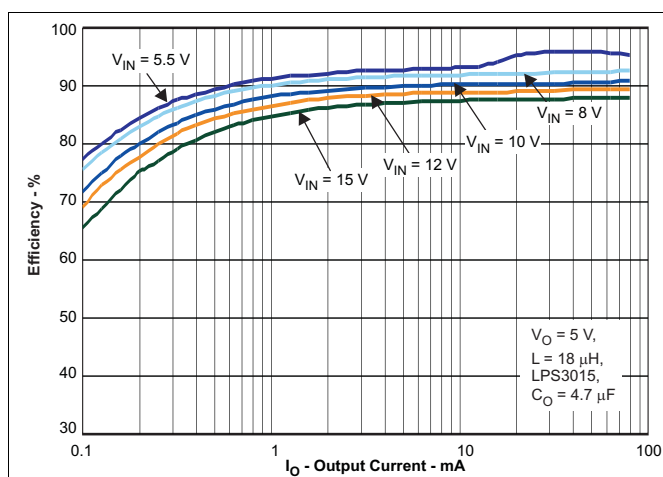

Figure 8. Efficiency vs Output Current I_{OUT} ($V_{OUT} = 5 V$)

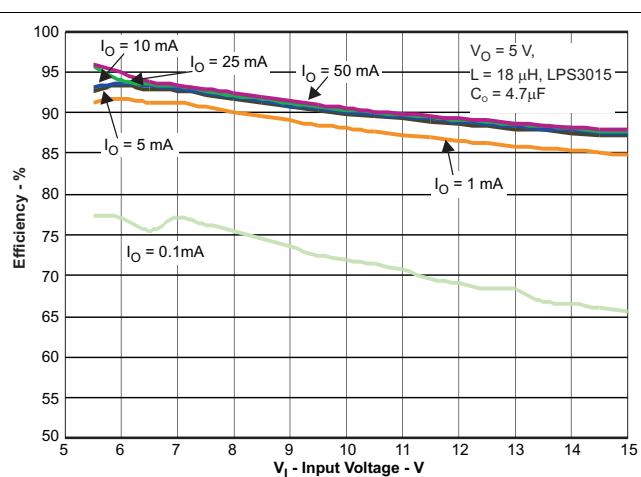

Figure 9. Efficiency vs Input Voltage V_{IN} ($V_{OUT} = 5 V$)

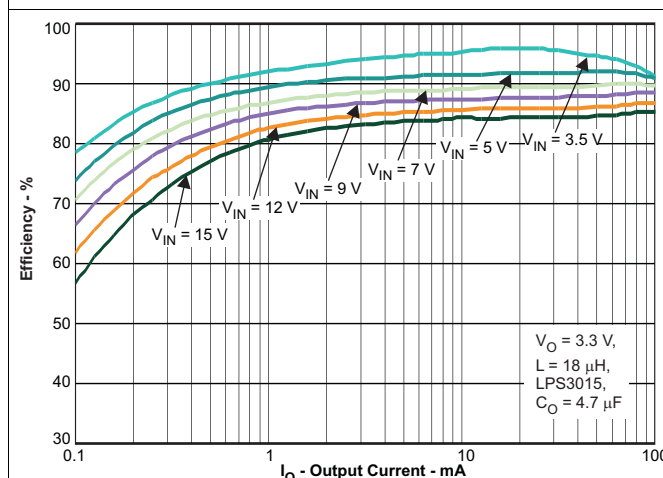

Figure 10. Efficiency vs Output Current I_{OUT} ($V_{OUT} = 3.3 V$)

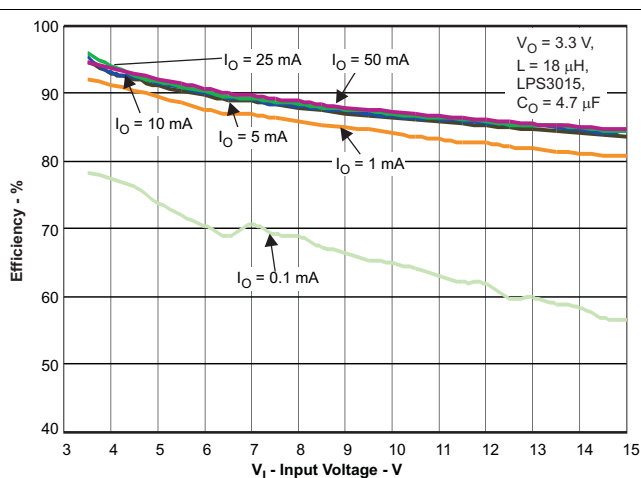

Figure 11. Efficiency vs Input Voltage V_{IN} ($V_{OUT} = 3.3 V$)

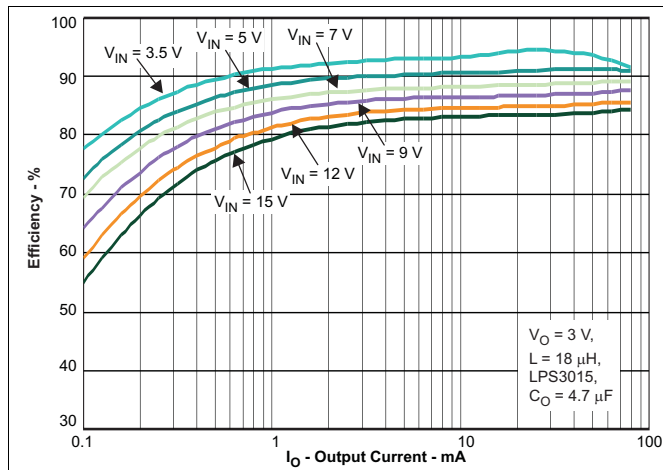

Figure 12. Efficiency vs Output Current $I_{O_{OUT}}$ ($V_{OUT} = 3\text{ V}$)

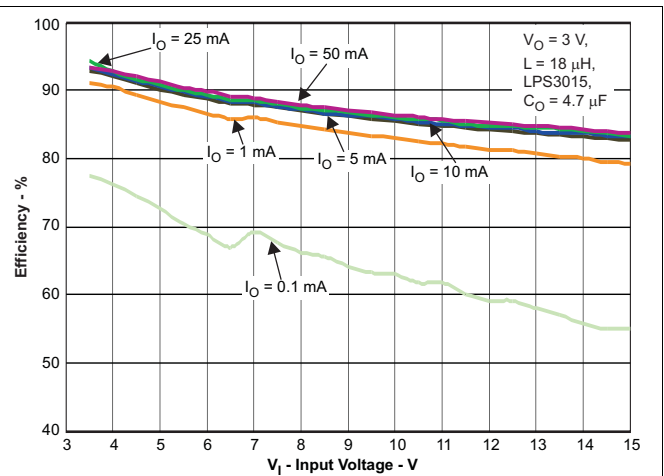

Figure 13. Efficiency vs Input Voltage V_{IN} ($V_{OUT} = 3\text{ V}$)

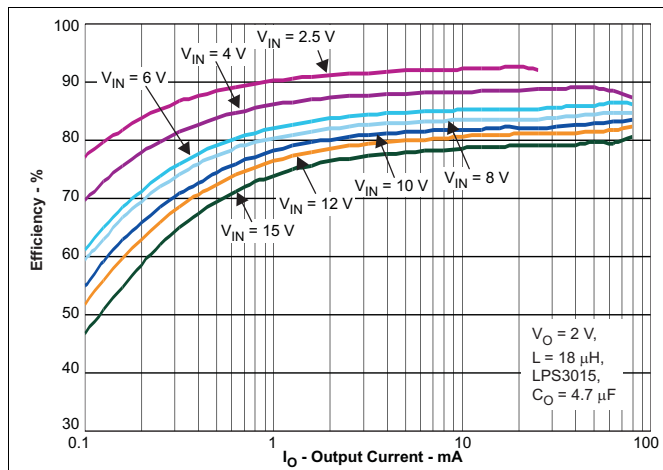

Figure 14. Efficiency vs Output Current $I_{O_{OUT}}$ ($V_{OUT} = 2\text{ V}$)

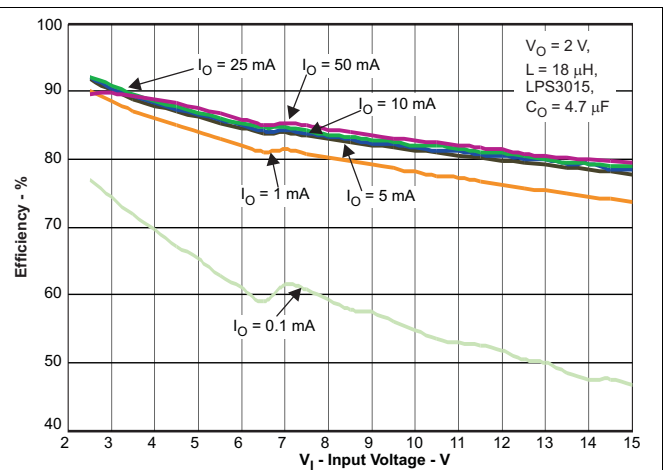

Figure 15. Efficiency vs Input Voltage V_{IN} ($V_{OUT} = 2\text{ V}$)

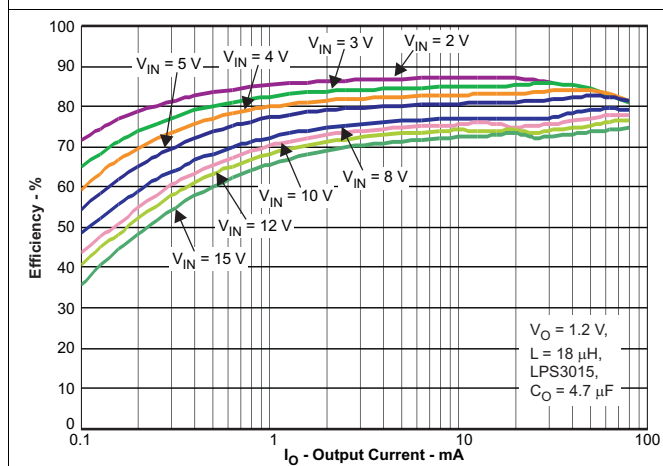

Figure 16. Efficiency vs Output Current $I_{O_{OUT}}$ ($V_{OUT} = 1.2\text{ V}$)

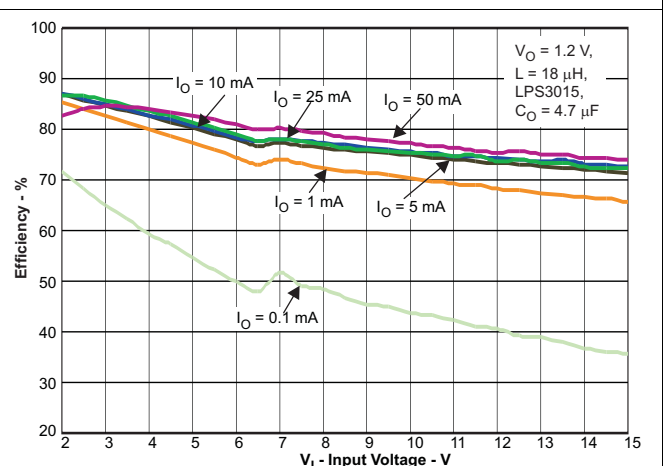

Figure 17. Efficiency vs Input Voltage V_{IN} ($V_{OUT} = 1.2\text{ V}$)

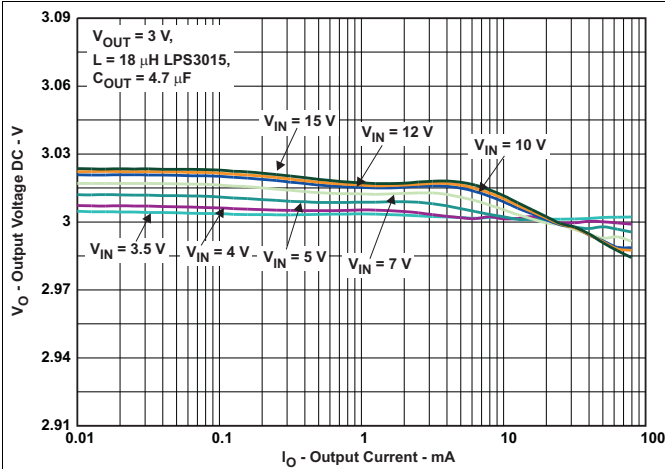

Figure 18. 3.0-V Output Voltage DC Regulation

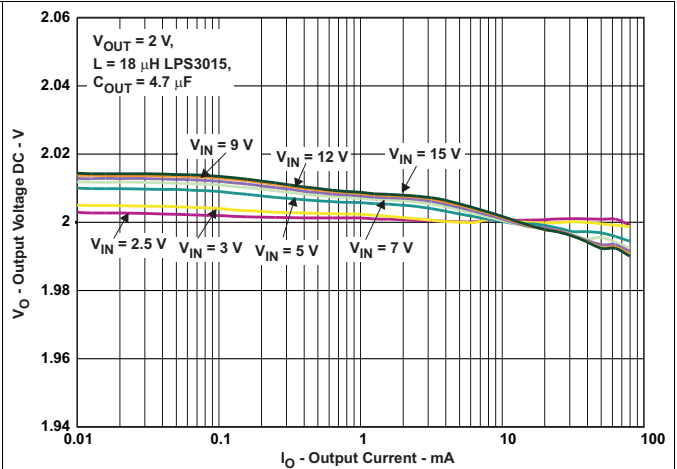

Figure 19. 2.0-V Output Voltage DC Regulation

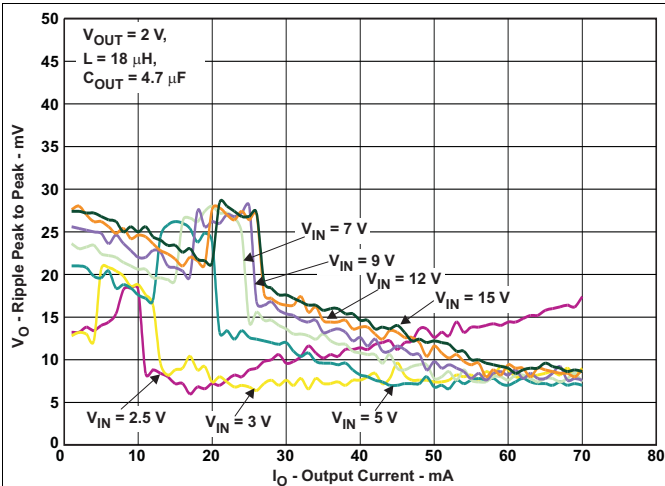

Figure 20. V_{OUT} 2.0-V Output Ripple Voltage Peak to Peak

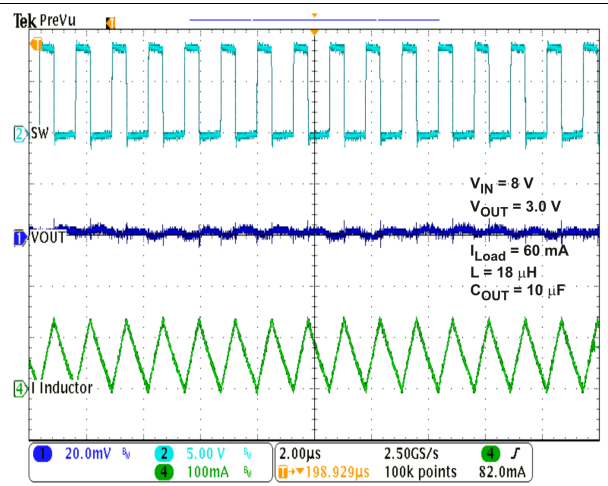

Figure 21. Typical Operation I_{OUT} 60mA

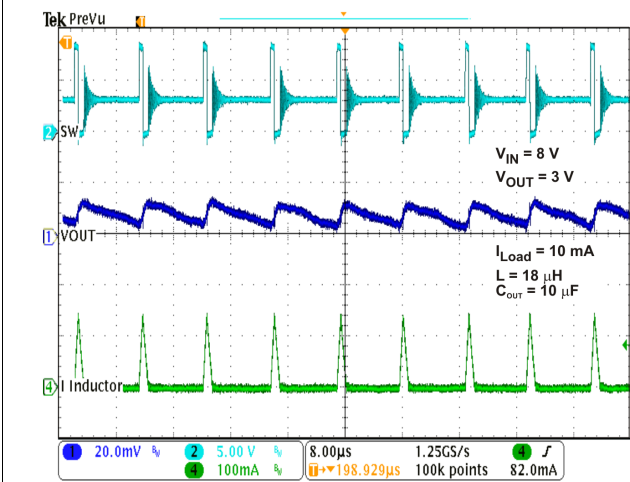

Figure 22. Typical Operation I_{OUT} 10mA

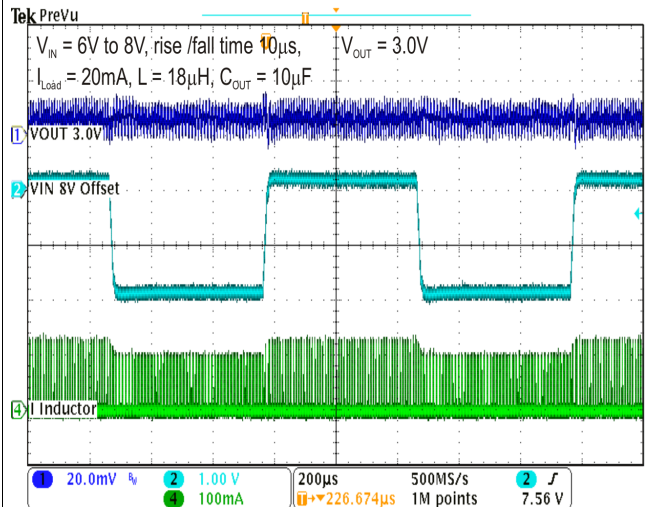
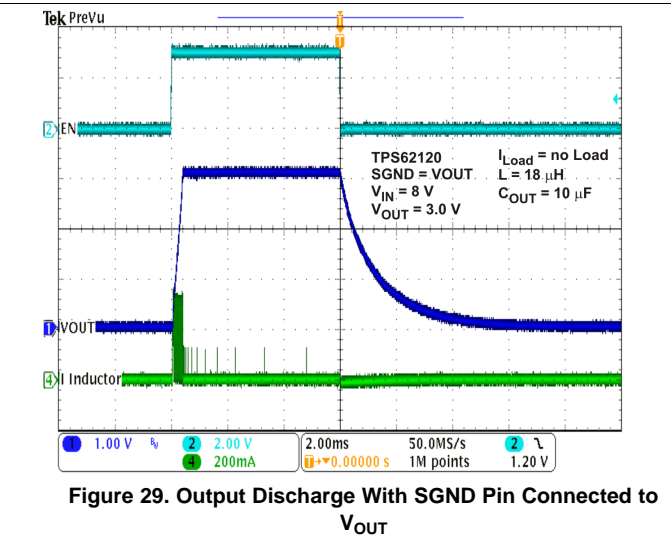
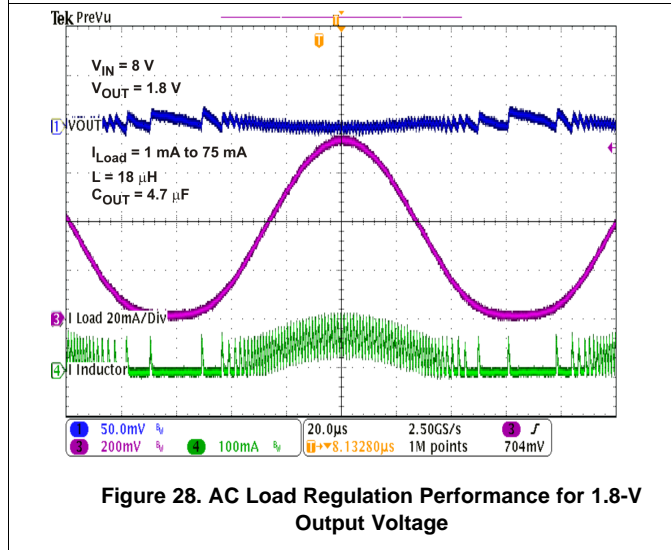
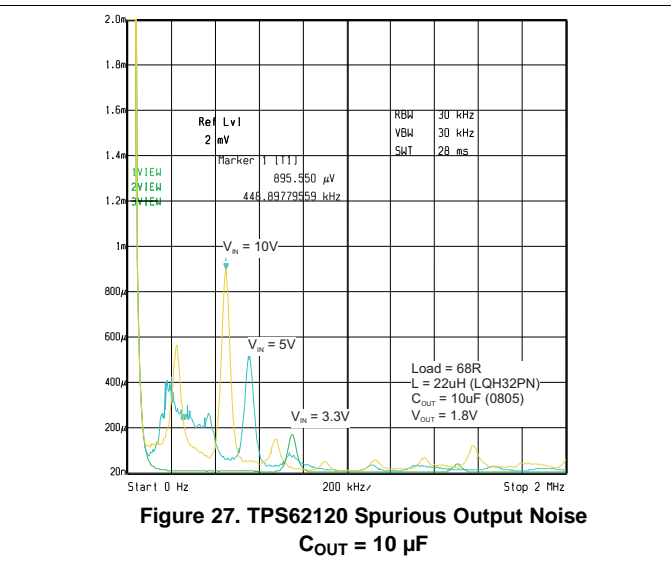
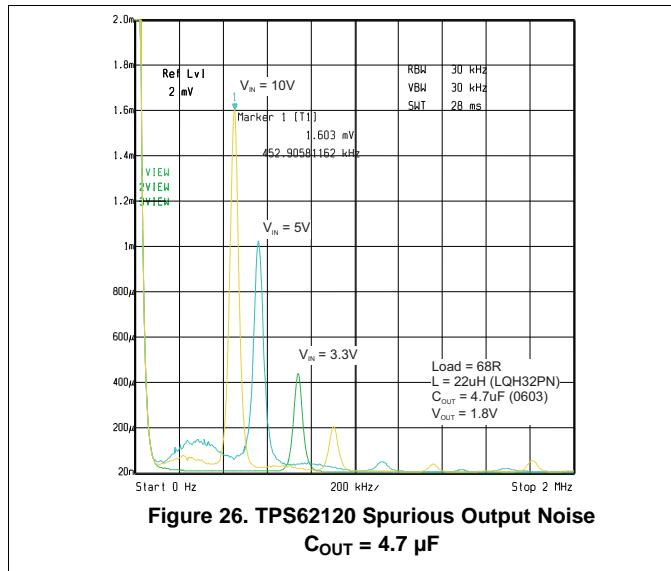
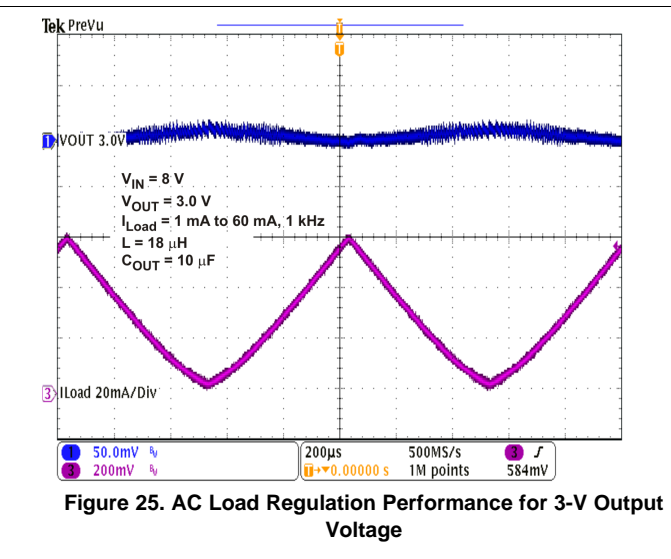
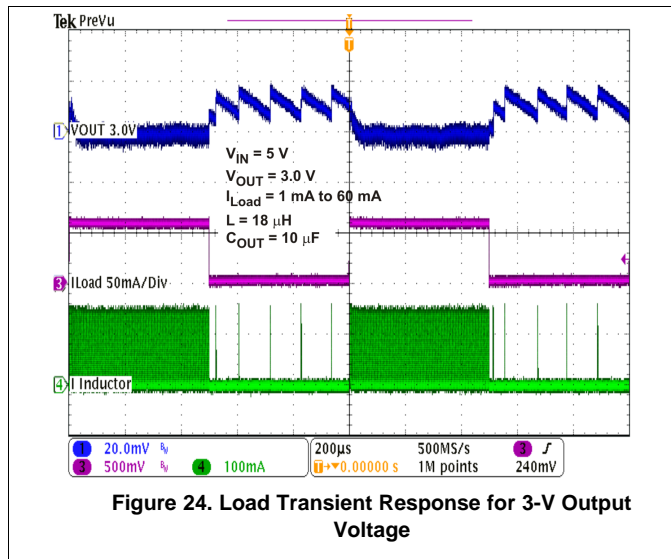
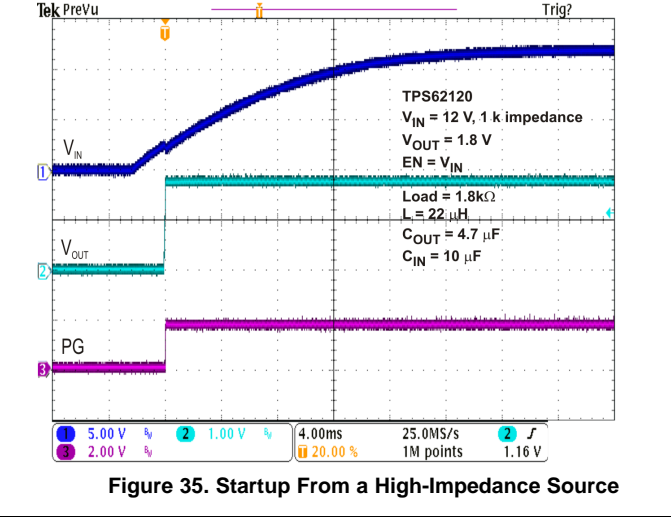
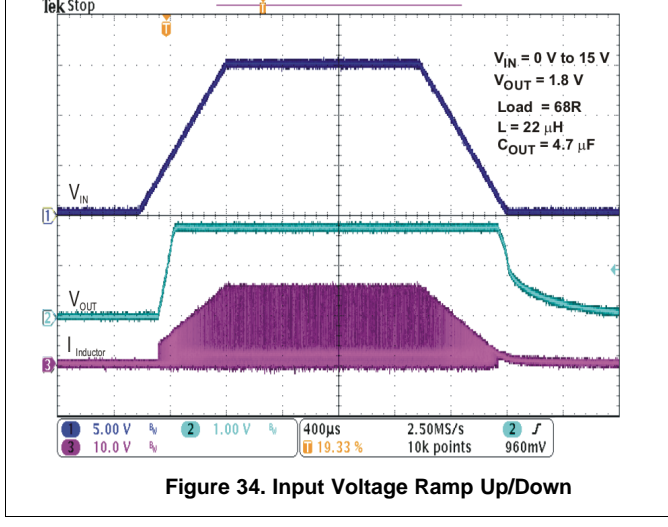
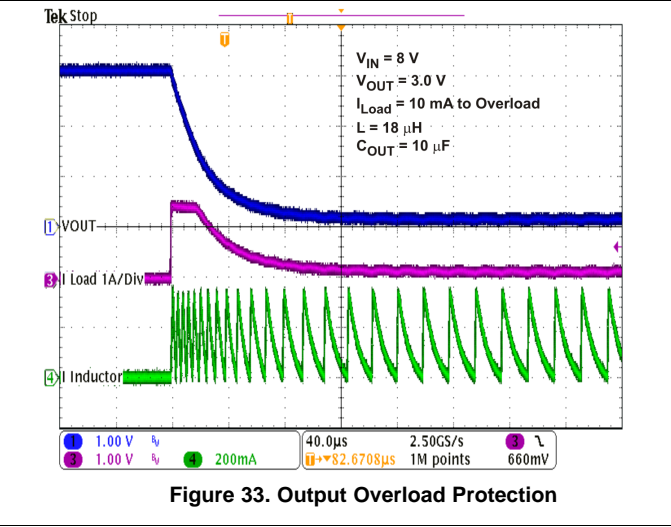
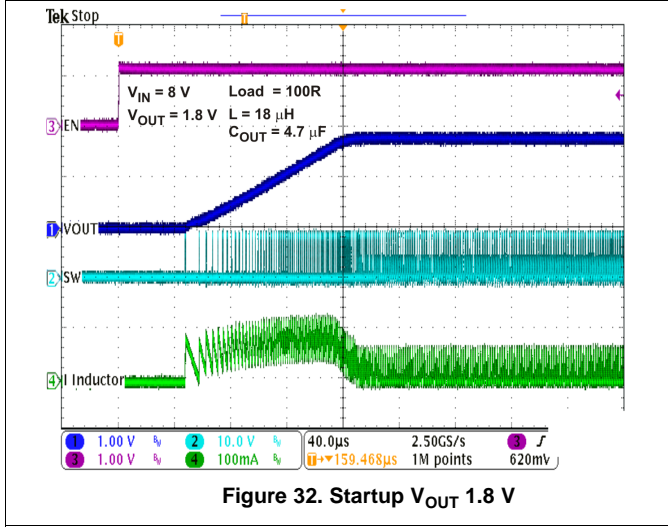
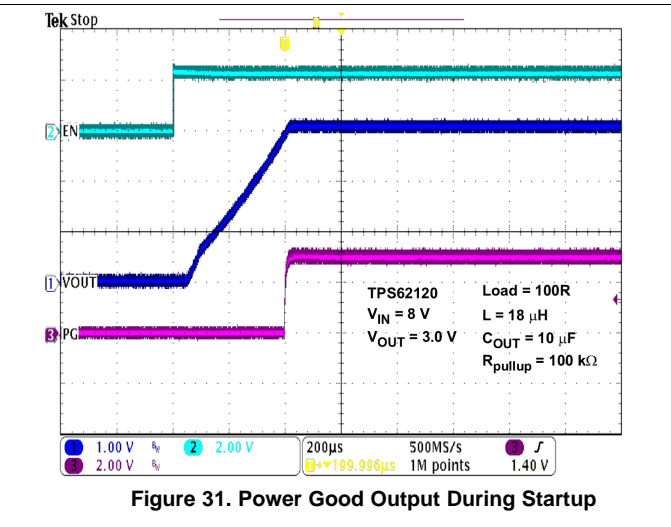
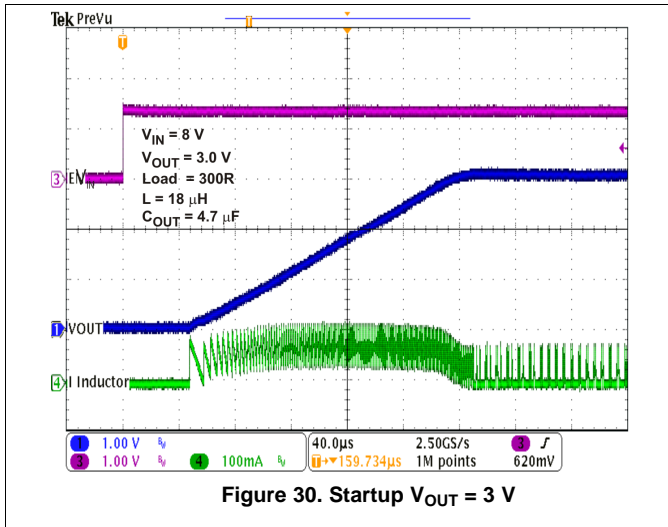

Figure 23. Line Transient Response for 3-V Output Voltage





9.2.2 Standard Circuit for TPS62122

Beside the power good open drain output (PG pin) and the open drain output for output discharge (SGND pin) the TPS62122 provides the same functionality as the TPS62120.

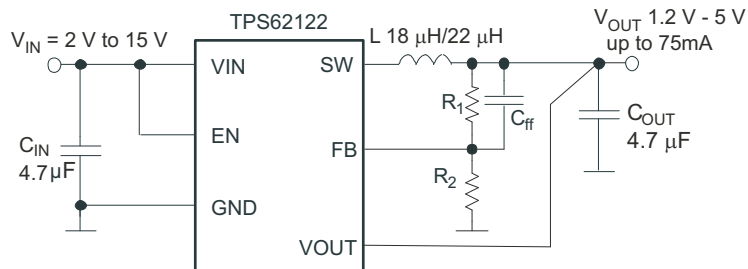

L = 18 μ H LPS3015 Coilcraft
 22 μ H LQH3NPN Murata
 C_{IN} : 4.7 μ F GRM21B series X5R (0805size) 25V Murata
 C_{OUT} : 4.7 μ F GRM188 series X5R (0603size) 6.3V Murata

Figure 36. Standard Circuit for TPS62122

9.3 System Examples

The TPS6212x is operating with a wide input voltage range from 2 V to 15 V. An open-drain power good output and an additional SGND pin is available in the TPS62120 for output voltage regulation and to discharge the output capacitor.

9.3.1 TPS62120 1.8-V Output Voltage Configuration

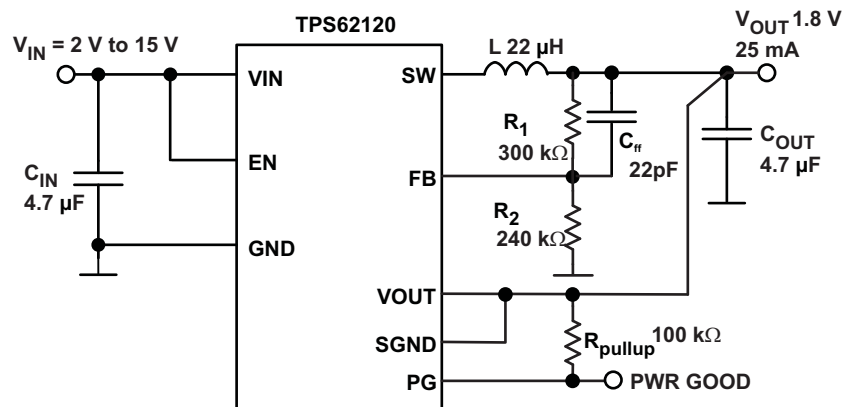

Figure 37. TPS62120 1.8-V Output Voltage Configuration

System Examples (continued)

9.3.2 TPS62120 3.06-V Output Voltage Configuration

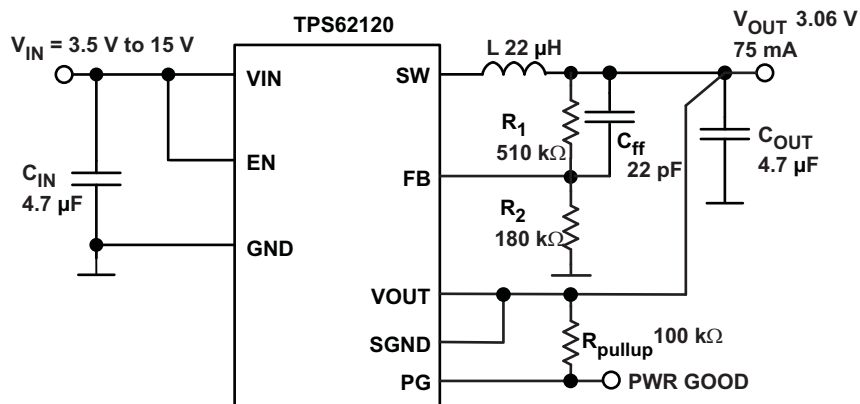

Figure 38. TPS62120 3.06-V Output Voltage Configuration

9.3.3 TPS62122 2.0-V Output Voltage Configuration

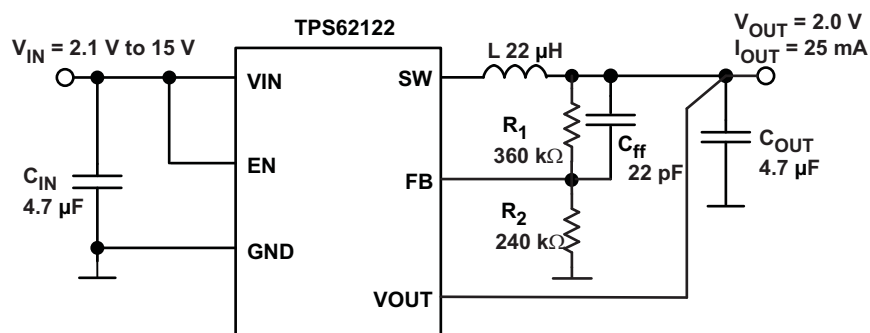

Figure 39. TPS62122 2.0-V Output Voltage Configuration

9.3.4 TPS62120 1.8-V VOUT Configuration Powered From a High-Impedance Source

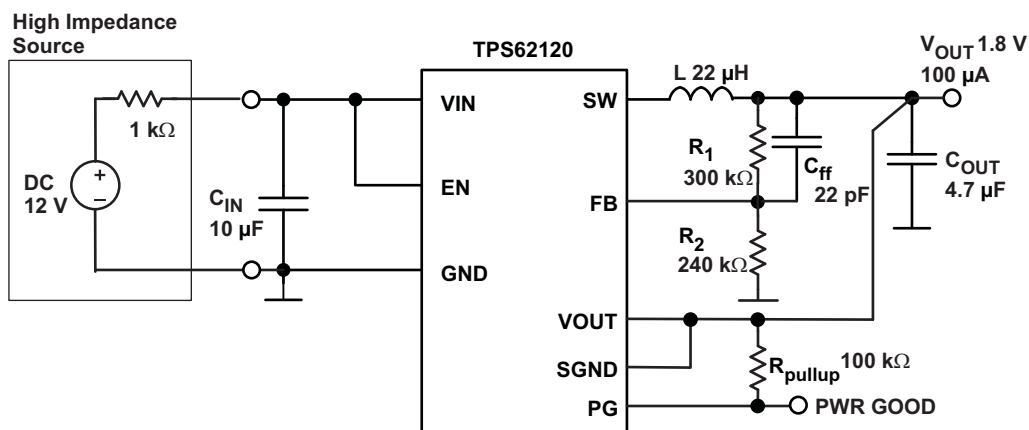

Figure 40. TPS62120 1.8-V VOUT Configuration Powered From a High-Impedance Source

10 Power Supply Recommendations

The TPS6212x device family has no special requirements for its input power supply. The output current of the input power supply needs to be rated according to the supply voltage, output voltage, and output current of the TPS6212x.

11 Layout

11.1 Layout Guidelines

As for all switching power supplies, the layout is an important step in the design. Proper function of the device demands careful attention to PCB layout. Care must be taken in board layout to get the specified performance. If the layout is not carefully done, the regulator could show poor line and/or load regulation, stability issues, as well as EMI problems. It is critical to provide a low inductance, impedance ground path. Therefore, use wide and short traces for the main current paths. The input capacitor should be placed as close as possible to the IC pins as well as the inductor and output capacitor.

Use a common Power GND node and a different node for the signal GND to minimize the effects of ground noise. Keep the common path to the GND PIN, which returns the small signal components and the high current of the output capacitors as short as possible to avoid ground noise. The FB divider network and the VOUT line must be connected to the output capacitor. The VOUT pin of the converter should be connected through a short trace to the output capacitor. The FB line must be routed away from noisy components and traces (for example, SW line).

11.2 Layout Examples

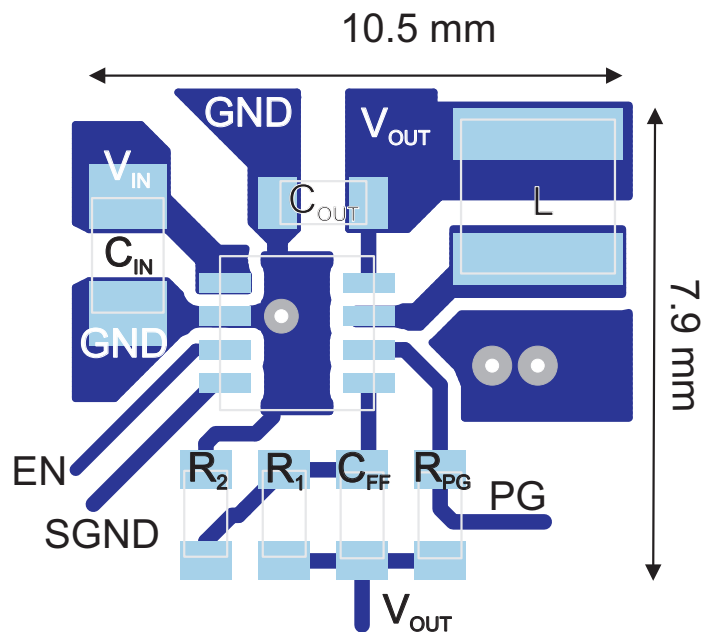

Figure 41. PCB Layout - DCN Package

Layout Examples (continued)

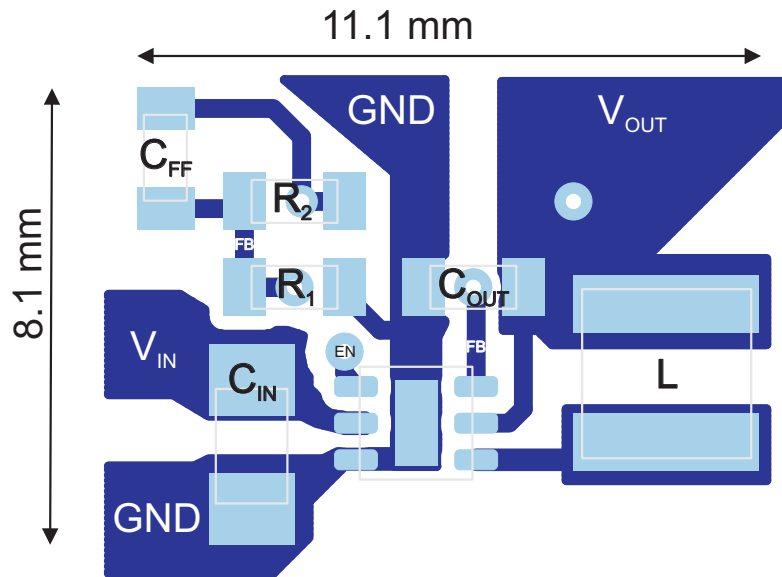

Figure 42. PCB Layout - DRV Package

12 Device and Documentation Support

12.1 Device Support

12.1.1 Third-Party Products Disclaimer

TI'S PUBLICATION OF INFORMATION REGARDING THIRD-PARTY PRODUCTS OR SERVICES DOES NOT CONSTITUTE AN ENDORSEMENT REGARDING THE SUITABILITY OF SUCH PRODUCTS OR SERVICES OR A WARRANTY, REPRESENTATION OR ENDORSEMENT OF SUCH PRODUCTS OR SERVICES, EITHER ALONE OR IN COMBINATION WITH ANY TI PRODUCT OR SERVICE.

12.2 Related Links

The table below lists quick access links. Categories include technical documents, support and community resources, tools and software, and quick access to sample or buy.

Table 4. Related Links

PARTS	PRODUCT FOLDER	SAMPLE & BUY	TECHNICAL DOCUMENTS	TOOLS & SOFTWARE	SUPPORT & COMMUNITY
TPS62120	Click here	Click here	Click here	Click here	Click here
TPS62122	Click here	Click here	Click here	Click here	Click here

12.3 Community Resources

The following links connect to TI community resources. Linked contents are provided "AS IS" by the respective contributors. They do not constitute TI specifications and do not necessarily reflect TI's views; see TI's [Terms of Use](#).

TI E2E™ Online Community *TI's Engineer-to-Engineer (E2E) Community*. Created to foster collaboration among engineers. At e2e.ti.com, you can ask questions, share knowledge, explore ideas and help solve problems with fellow engineers.

Design Support *TI's Design Support* Quickly find helpful E2E forums along with design support tools and contact information for technical support.

12.4 Trademarks

E2E is a trademark of Texas Instruments.
All other trademarks are the property of their respective owners.

12.5 Electrostatic Discharge Caution



These devices have limited built-in ESD protection. The leads should be shorted together or the device placed in conductive foam during storage or handling to prevent electrostatic damage to the MOS gates.

12.6 Glossary

SLYZ022 — *TI Glossary*.

This glossary lists and explains terms, acronyms, and definitions.

13 Mechanical, Packaging, and Orderable Information

The following pages include mechanical, packaging, and orderable information. This information is the most current data available for the designated devices. This data is subject to change without notice and revision of this document. For browser-based versions of this data sheet, refer to the left-hand navigation.

PACKAGING INFORMATION

Orderable Device	Status (1)	Package Type	Package Drawing	Pins	Package Qty	Eco Plan (2)	Lead finish/ Ball material (6)	MSL Peak Temp (3)	Op Temp (°C)	Device Marking (4/5)	Samples
TPS62120DCNR	ACTIVE	SOT-23	DCN	8	3000	RoHS & Green	NIPDAU	Level-1-260C-UNLIM	-40 to 85	QTX	Samples
TPS62120DCNT	ACTIVE	SOT-23	DCN	8	250	RoHS & Green	NIPDAU	Level-1-260C-UNLIM	-40 to 85	QTX	Samples
TPS62122DRVR	ACTIVE	WSON	DRV	6	3000	RoHS & Green	NIPDAU NIPDAUAG	Level-2-260C-1 YEAR	-40 to 85	OFZ	Samples
TPS62122DRVT	ACTIVE	WSON	DRV	6	250	RoHS & Green	NIPDAU NIPDAUAG	Level-2-260C-1 YEAR	-40 to 85	OFZ	Samples

(1) The marketing status values are defined as follows:

ACTIVE: Product device recommended for new designs.

LIFEBUY: TI has announced that the device will be discontinued, and a lifetime-buy period is in effect.

NRND: Not recommended for new designs. Device is in production to support existing customers, but TI does not recommend using this part in a new design.

PREVIEW: Device has been announced but is not in production. Samples may or may not be available.

OBSELETE: TI has discontinued the production of the device.

(2) **RoHS:** TI defines "RoHS" to mean semiconductor products that are compliant with the current EU RoHS requirements for all 10 RoHS substances, including the requirement that RoHS substance do not exceed 0.1% by weight in homogeneous materials. Where designed to be soldered at high temperatures, "RoHS" products are suitable for use in specified lead-free processes. TI may reference these types of products as "Pb-Free".

RoHS Exempt: TI defines "RoHS Exempt" to mean products that contain lead but are compliant with EU RoHS pursuant to a specific EU RoHS exemption.

Green: TI defines "Green" to mean the content of Chlorine (Cl) and Bromine (Br) based flame retardants meet JS709B low halogen requirements of <=1000ppm threshold. Antimony trioxide based flame retardants must also meet the <=1000ppm threshold requirement.

(3) MSL, Peak Temp. - The Moisture Sensitivity Level rating according to the JEDEC industry standard classifications, and peak solder temperature.

(4) There may be additional marking, which relates to the logo, the lot trace code information, or the environmental category on the device.

(5) Multiple Device Markings will be inside parentheses. Only one Device Marking contained in parentheses and separated by a "-" will appear on a device. If a line is indented then it is a continuation of the previous line and the two combined represent the entire Device Marking for that device.

(6) Lead finish/Ball material - Orderable Devices may have multiple material finish options. Finish options are separated by a vertical ruled line. Lead finish/Ball material values may wrap to two lines if the finish value exceeds the maximum column width.

Important Information and Disclaimer:The information provided on this page represents TI's knowledge and belief as of the date that it is provided. TI bases its knowledge and belief on information provided by third parties, and makes no representation or warranty as to the accuracy of such information. Efforts are underway to better integrate information from third parties. TI has taken and

continues to take reasonable steps to provide representative and accurate information but may not have conducted destructive testing or chemical analysis on incoming materials and chemicals. TI and TI suppliers consider certain information to be proprietary, and thus CAS numbers and other limited information may not be available for release.

In no event shall TI's liability arising out of such information exceed the total purchase price of the TI part(s) at issue in this document sold by TI to Customer on an annual basis.

TAPE AND REEL INFORMATION

QUADRANT ASSIGNMENTS FOR PIN 1 ORIENTATION IN TAPE

*All dimensions are nominal

Device	Package Type	Package Drawing	Pins	SPQ	Reel Diameter (mm)	Reel Width W1 (mm)	A0 (mm)	B0 (mm)	K0 (mm)	P1 (mm)	W (mm)	Pin1 Quadrant
TPS62120DCNR	SOT-23	DCN	8	3000	180.0	8.4	3.23	3.17	1.37	4.0	8.0	Q3
TPS62120DCNR	SOT-23	DCN	8	3000	179.0	8.4	3.2	3.2	1.4	4.0	8.0	Q3
TPS62120DCNT	SOT-23	DCN	8	250	180.0	8.4	3.23	3.17	1.37	4.0	8.0	Q3
TPS62120DCNT	SOT-23	DCN	8	250	179.0	8.4	3.2	3.2	1.4	4.0	8.0	Q3
TPS62122DRVR	WSON	DRV	6	3000	180.0	8.4	2.3	2.3	1.15	4.0	8.0	Q2
TPS62122DRVT	WSON	DRV	6	250	178.0	8.4	2.25	2.25	1.0	4.0	8.0	Q2
TPS62122DRVT	WSON	DRV	6	250	179.0	8.4	2.2	2.2	1.2	4.0	8.0	Q2

TAPE AND REEL BOX DIMENSIONS

*All dimensions are nominal

Device	Package Type	Package Drawing	Pins	SPQ	Length (mm)	Width (mm)	Height (mm)
TPS62120DCNR	SOT-23	DCN	8	3000	183.0	183.0	20.0
TPS62120DCNR	SOT-23	DCN	8	3000	200.0	183.0	25.0
TPS62120DCNT	SOT-23	DCN	8	250	183.0	183.0	20.0
TPS62120DCNT	SOT-23	DCN	8	250	200.0	183.0	25.0
TPS62122DRVR	WSON	DRV	6	3000	210.0	185.0	35.0
TPS62122DRVT	WSON	DRV	6	250	205.0	200.0	33.0
TPS62122DRVT	WSON	DRV	6	250	200.0	183.0	25.0

GENERIC PACKAGE VIEW

DRV 6

WSON - 0.8 mm max height

PLASTIC SMALL OUTLINE - NO LEAD



Images above are just a representation of the package family, actual package may vary.
Refer to the product data sheet for package details.

4206925/F

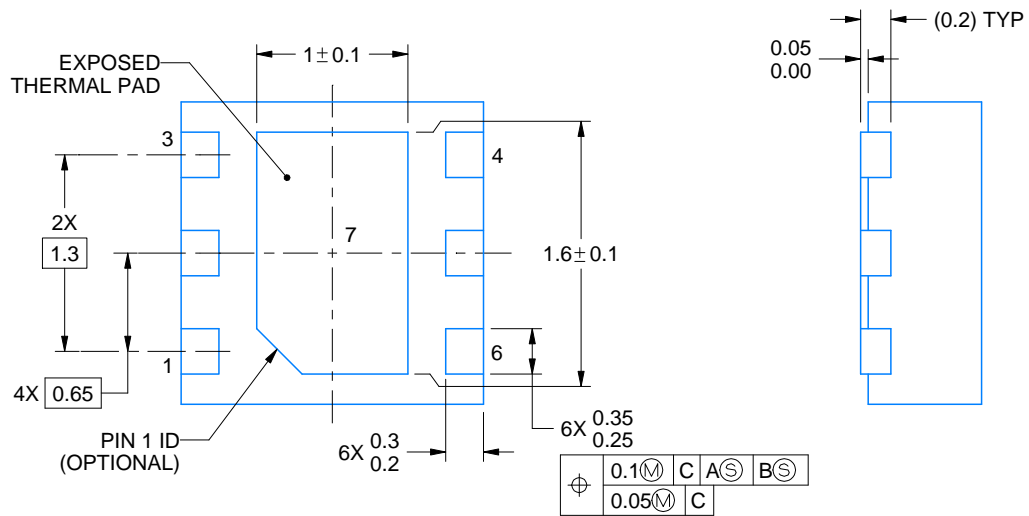
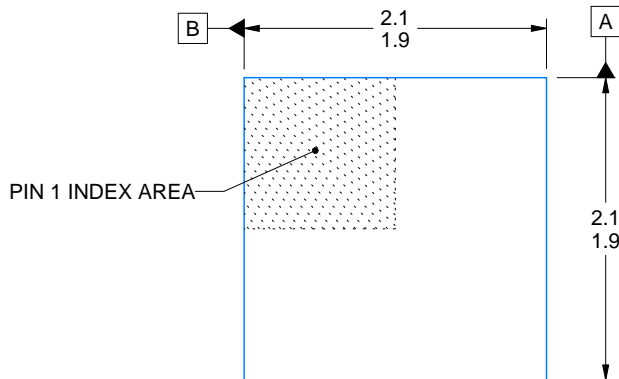
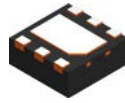

4222173/B 04/2018

NOTES:

1. All linear dimensions are in millimeters. Any dimensions in parenthesis are for reference only. Dimensioning and tolerancing per ASME Y14.5M.
2. This drawing is subject to change without notice.
3. The package thermal pad must be soldered to the printed circuit board for thermal and mechanical performance.

EXAMPLE STENCIL DESIGN

DRV0006A

WSON - 0.8 mm max height

PLASTIC SMALL OUTLINE - NO LEAD



SOLDER PASTE EXAMPLE
BASED ON 0.125 mm THICK STENCIL

EXPOSED PAD #7
88% PRINTED SOLDER COVERAGE BY AREA UNDER PACKAGE
SCALE:30X

4222173/B 04/2018

NOTES: (continued)

6. Laser cutting apertures with trapezoidal walls and rounded corners may offer better paste release. IPC-7525 may have alternate design recommendations.

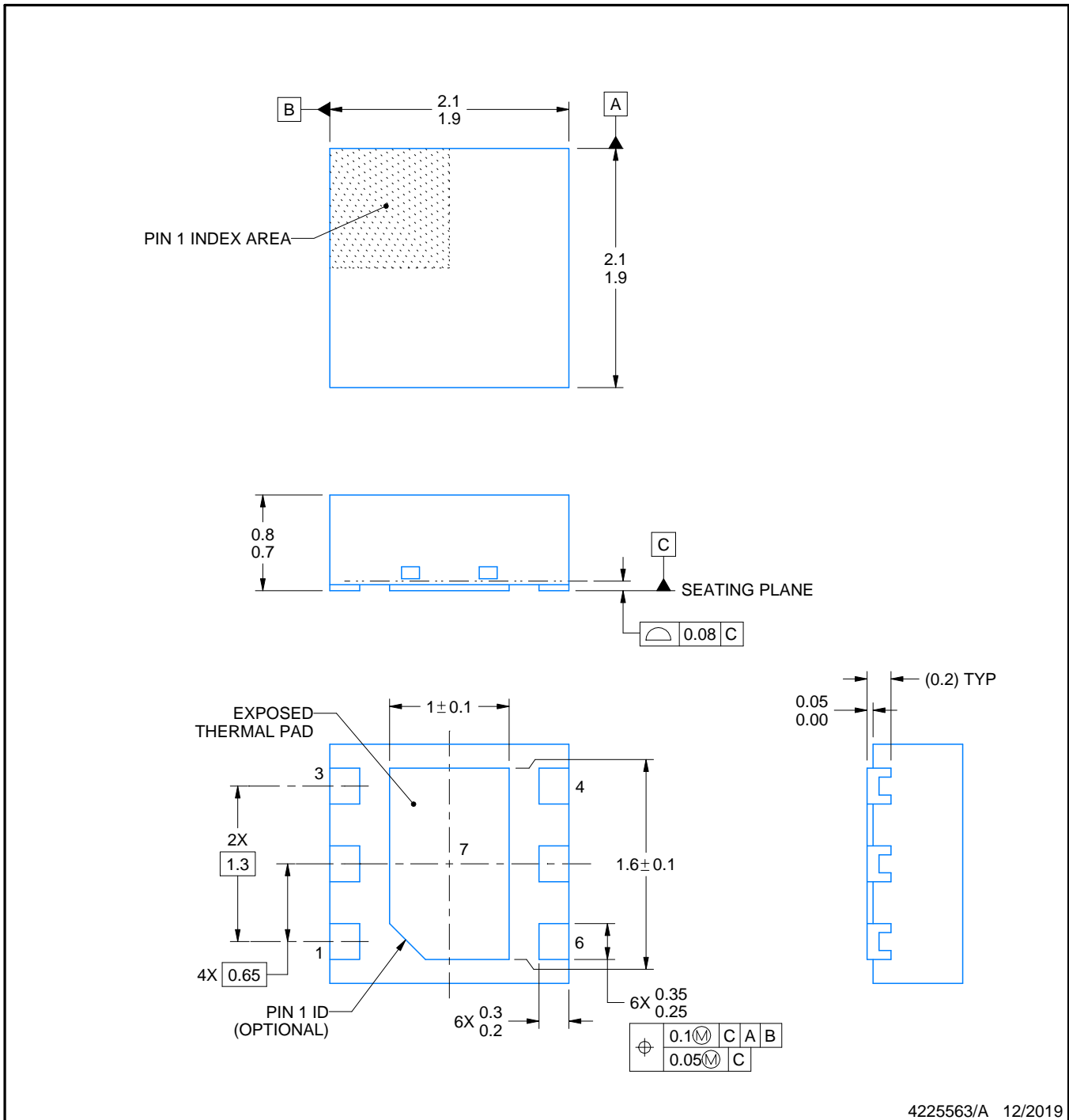
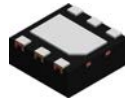

4225563/A 12/2019

NOTES:

1. All linear dimensions are in millimeters. Any dimensions in parenthesis are for reference only. Dimensioning and tolerancing per ASME Y14.5M.
2. This drawing is subject to change without notice.
3. The package thermal pad must be soldered to the printed circuit board for thermal and mechanical performance.

EXAMPLE BOARD LAYOUT

DRV0006D

WSON - 0.8 mm max height

PLASTIC SMALL OUTLINE - NO LEAD

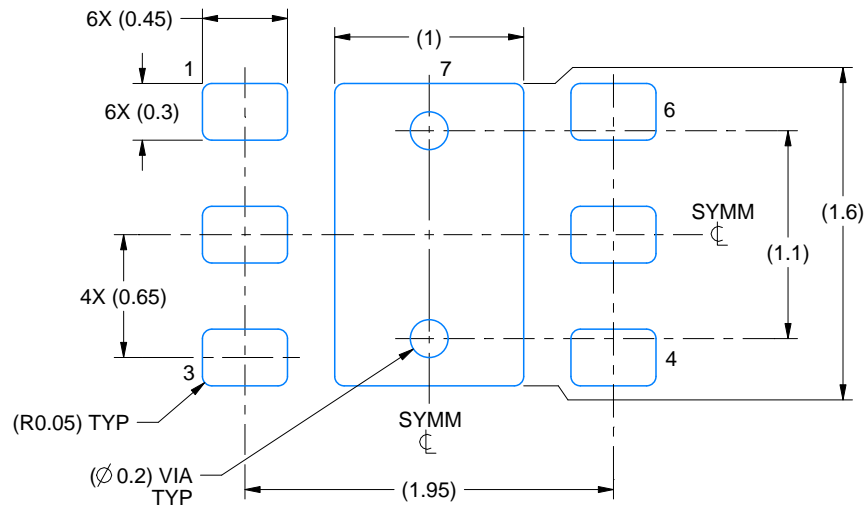

LAND PATTERN EXAMPLE
EXPOSED METAL SHOWN
SCALE:25X

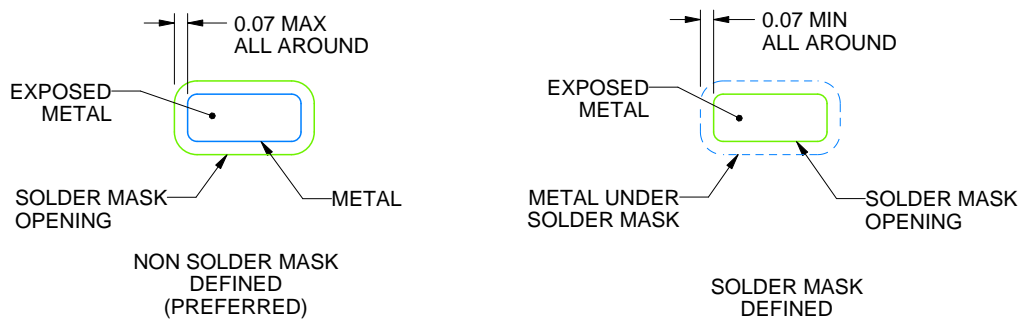

SOLDER MASK DETAILS

4225563/A 12/2019

NOTES: (continued)

4. This package is designed to be soldered to a thermal pad on the board. For more information, see Texas Instruments literature number SLUA271 (www.ti.com/lit/sluea271).
5. Vias are optional depending on application, refer to device data sheet. If some or all are implemented, recommended via locations are shown.

EXAMPLE STENCIL DESIGN

DRV0006D

WSON - 0.8 mm max height

PLASTIC SMALL OUTLINE - NO LEAD



SOLDER PASTE EXAMPLE
BASED ON 0.125 mm THICK STENCIL

EXPOSED PAD #7
88% PRINTED SOLDER COVERAGE BY AREA UNDER PACKAGE
SCALE:30X

4225563/A 12/2019

NOTES: (continued)

6. Laser cutting apertures with trapezoidal walls and rounded corners may offer better paste release. IPC-7525 may have alternate design recommendations.

DCN (R-PDSO-G8)

PLASTIC SMALL-OUTLINE PACKAGE (DIE DOWN)

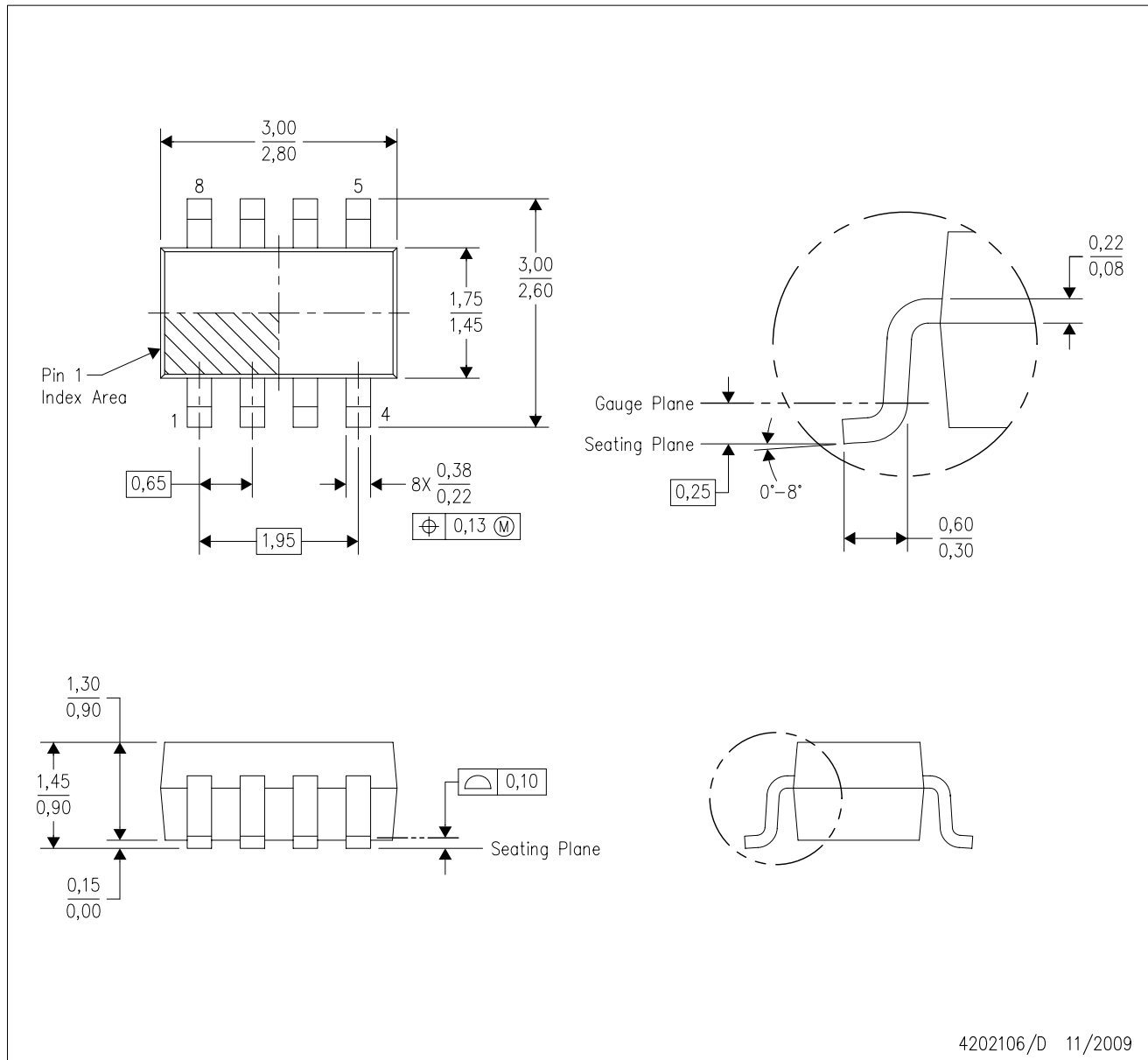

4202106/D 11/2009

- NOTES:
- A. All linear dimensions are in millimeters.
 - B. This drawing is subject to change without notice.
 - C. Package outline exclusive of metal burr & dambar protrusion/intrusion.
 - D. Package outline inclusive of solder plating.
 - E. A visual index feature must be located within the Pin 1 index area.
 - F. Falls within JEDEC MO-178 Variation BA.
 - G. Body dimensions do not include flash or protrusion. Mold flash and protrusion shall not exceed 0.25 per side.

DCN (R-PDSO-G8)

PLASTIC SMALL-OUTLINE PACKAGE (DIE DOWN)



- NOTES:
- A. All linear dimensions are in millimeters.
 - B. This drawing is subject to change without notice.
 - C. Publication IPC-7351 is recommended for alternate designs.
 - D. Laser cutting apertures with trapezoidal walls and also rounding corners will offer better paste release. Customers should contact their board assembly site for stencil design recommendations. Refer to IPC-7525.
 - E. Customers should contact their board fabrication site for solder mask tolerances between and around signal pads.

IMPORTANT NOTICE AND DISCLAIMER

TI PROVIDES TECHNICAL AND RELIABILITY DATA (INCLUDING DATA SHEETS), DESIGN RESOURCES (INCLUDING REFERENCE DESIGNS), APPLICATION OR OTHER DESIGN ADVICE, WEB TOOLS, SAFETY INFORMATION, AND OTHER RESOURCES "AS IS" AND WITH ALL FAULTS, AND DISCLAIMS ALL WARRANTIES, EXPRESS AND IMPLIED, INCLUDING WITHOUT LIMITATION ANY IMPLIED WARRANTIES OF MERCHANTABILITY, FITNESS FOR A PARTICULAR PURPOSE OR NON-INFRINGEMENT OF THIRD PARTY INTELLECTUAL PROPERTY RIGHTS.

These resources are intended for skilled developers designing with TI products. You are solely responsible for (1) selecting the appropriate TI products for your application, (2) designing, validating and testing your application, and (3) ensuring your application meets applicable standards, and any other safety, security, regulatory or other requirements.

These resources are subject to change without notice. TI grants you permission to use these resources only for development of an application that uses the TI products described in the resource. Other reproduction and display of these resources is prohibited. No license is granted to any other TI intellectual property right or to any third party intellectual property right. TI disclaims responsibility for, and you will fully indemnify TI and its representatives against, any claims, damages, costs, losses, and liabilities arising out of your use of these resources.

TI's products are provided subject to [TI's Terms of Sale](#) or other applicable terms available either on [ti.com](https://www.ti.com) or provided in conjunction with such TI products. TI's provision of these resources does not expand or otherwise alter TI's applicable warranties or warranty disclaimers for TI products.

TI objects to and rejects any additional or different terms you may have proposed.

Mailing Address: Texas Instruments, Post Office Box 655303, Dallas, Texas 75265
Copyright © 2023, Texas Instruments Incorporated

Looking for pricing, stock, or lifecycle information?

Click below to explore more details on WIN SOURCE:

 [View TPS62122DRVT on WIN SOURCE](#)

 [Texas Instruments](#) Information

Optimize Your Supply Chain with WIN SOURCE Solutions

-  Global Sourcing Solution
-  Obsolete Management
-  Cost Control Management
-  Shortage Management
-  Alternative Solution
-  Excess Inventory Management