



# THE DATASHEET OF TPS63061DSCT



## TPS6306x High Input Voltage, Buck-Boost Converter With 2-A Switch Current

### 1 Features

- Input Voltage Range: 2.5 V to 12 V
- Efficiency: Up to 93%
- Output Current at 5 V ( $V_{IN} < 10$  V): 2 A in Buck Mode
- Output Current at 5 V ( $V_{IN} > 4$  V): 1.3 A in Boost Mode
- Automatic Transition Between Step Down and Boost Mode
- Typical Device Quiescent Current:  $< 30 \mu\text{A}$
- Fixed and Adjustable Output Voltage Options from 2.5 V to 8 V
- Power-Save Mode for Improved Efficiency at Low Output Power
- Forced Fixed-Frequency Operation at 2.4 MHz and Synchronization Possible
- Power Good Output
- Buck-Boost Overlap Control™
- Load Disconnect During Shutdown
- Overtemperature Protection
- Overvoltage Protection

### 2 Applications

- Dual Li-Ion Application
- DSCs and Camcorders
- Notebook Computer
- Industrial Metering Equipment
- Ultra Mobile PCs and Mobile Internet Devices
- Personal Medical Products
- High-Power LEDs

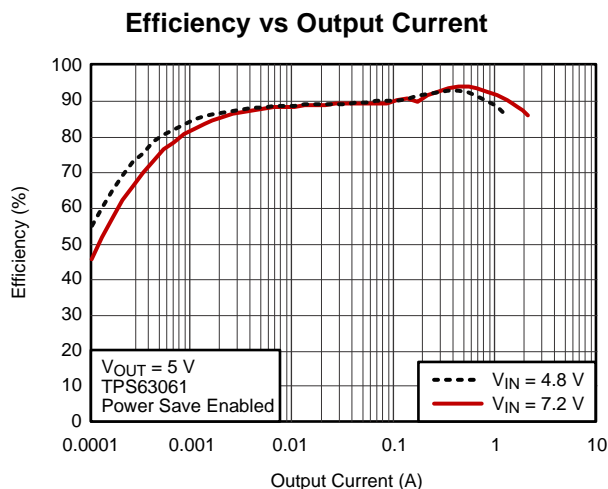

### 3 Description

The TPS6306x devices provide a power supply solution for products powered by either three-cell up to six-cell alkaline, NiCd or NiMH battery, or a one-cell or dual-cell Li-Ion or Li-polymer battery. Output currents can go as high as 2-A while using a dual-cell Li-Ion or Li-polymer battery, and discharge it down to 5 V or lower. The buck-boost converter is based on a fixed frequency, pulse-width-modulation (PWM) controller using synchronous rectification to obtain maximum efficiency. At low load currents, the converter enters power-save mode to maintain high efficiency over a wide load current range. The power-save mode can be disabled, forcing the converter to operate at a fixed switching frequency. The maximum average current in the switches is limited to a typical value of 2.25 A. The output voltage is programmable using an external resistor divider, or is fixed internally on the chip. The converter can be disabled to minimize battery drain. During shutdown, the load is disconnected from the battery.

The devices are available in a 3 mm × 3 mm, 10-pin, WSON (DSC), PowerPAD™ package.

#### Device Information<sup>(1)</sup>

PART NUMBER	PACKAGE	BODY SIZE (NOM)
TPS63060	WSON (10)	3.00 mm × 3.00 mm
TPS63061		

(1) For all available packages, see the orderable addendum at the end of the data sheet.

#### Simplified Schematic

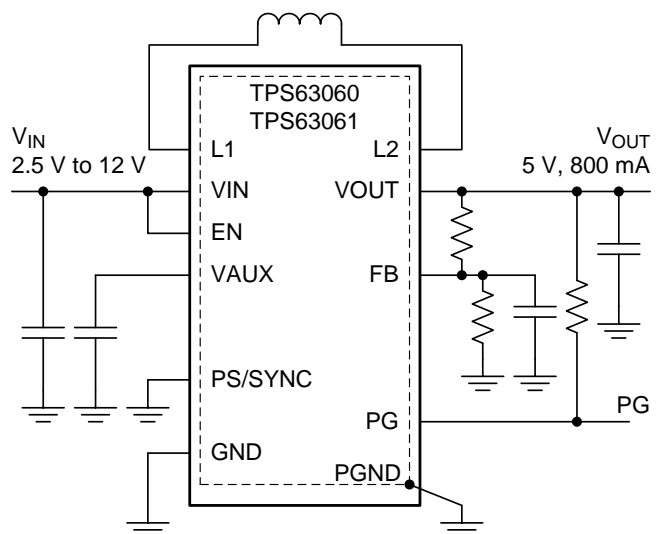

## Table of Contents

<b>1 Features</b> ..... 1 <b>2 Applications</b> ..... 1 <b>3 Description</b> ..... 1 <b>4 Revision History</b> ..... 2 <b>5 Device Comparison Table</b> ..... 3 <b>6 Pin Configuration and Functions</b> ..... 3 <b>7 Specifications</b> ..... 4 7.1 Absolute Maximum Ratings ..... 4 7.2 ESD Ratings..... 4 7.3 Recommended Operating Conditions ..... 4 7.4 Thermal Information ..... 4 7.5 Electrical Characteristics..... 5 7.6 Typical Characteristics ..... 6 <b>8 Detailed Description</b> ..... 6 8.1 Overview ..... 6 8.2 Functional Block Diagrams ..... 7 8.3 Feature Description..... 8	8.4 Device Functional Modes..... 8 <b>9 Application and Implementation</b> ..... 12 9.1 Application Information..... 12 9.2 Typical Application ..... 12 <b>10 Power Supply Recommendations</b> ..... 20 <b>11 Layout</b> ..... 21 11.1 Layout Guidelines ..... 21 11.2 Layout Example ..... 21 <b>12 Device and Documentation Support</b> ..... 22 12.1 Device Support ..... 22 12.2 Documentation Support ..... 22 12.3 Related Links ..... 22 12.4 Trademarks ..... 22 12.5 Electrostatic Discharge Caution..... 22 12.6 Glossary ..... 22 <b>13 Mechanical, Packaging, and Orderable Information</b> ..... 22
---	--

## 4 Revision History

NOTE: Page numbers for previous revisions may differ from page numbers in the current version.

Changes from Revision A (February 2012) to Revision B	Page
<ul style="list-style-type: none"> <li>• Added <i>ESD Ratings</i> table, <i>Feature Description</i> section, <i>Device Functional Modes</i> section, <i>Application and Implementation</i> section, <i>Power Supply Recommendations</i> section, <i>Layout</i> section, <i>Device and Documentation Support</i> section, and <i>Mechanical, Packaging, and Orderable Information</i> section.....</li> </ul>	1

## 5 Device Comparison Table

ORDER NUMBER <sup>(1)(2)</sup>	PACKAGE MARKING	OUTPUT VOLTAGE DC/DC
TPS63060DSC	QUJ	Adjustable
TPS63061DSC	QUK	5 V

- (1) For detailed ordering information please check the *Package Option Addendum* section at the end of this data sheet.  
 (2) Contact the factory to confirm availability of other fixed-output voltage versions.

## 6 Pin Configuration and Functions

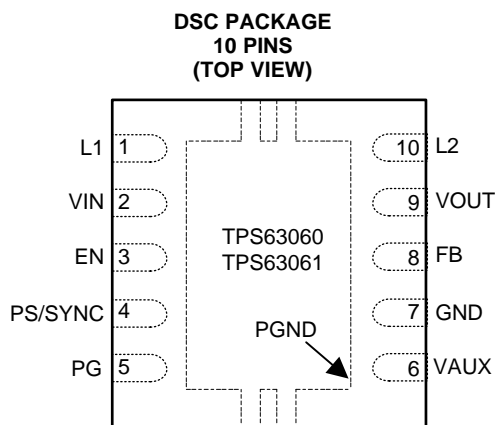

### Pin Functions

PIN		I/O	DESCRIPTION
NAME	NO.		
EN	3	I	Enable input. (1 enabled, 0 disabled)
FB	8	I	Voltage feedback of adjustable versions, must be connected to VOUT on fixed output voltage versions
GND	7		Control and logic ground
L1	1	I	Connection for Inductor
L2	10	I	Connection for Inductor
PG	5	O	Output power good (1 good, 0 failure; open drain)
PS/SYNC	4	I	Enable / disable power save mode (1 disabled, 0 enabled, clock signal for synchronization)
VAUX	6		Connection for Capacitor
VIN	2	I	Supply voltage for power stage
VOUT	9	O	Buck-boost converter output
PowerPAD™			Power ground. Must be soldered to achieve appropriate power dissipation. Must be connected to PGND.

## 7 Specifications

### 7.1 Absolute Maximum Ratings

over operating free-air temperature range (unless otherwise noted)<sup>(1)</sup>

		MIN	MAX	UNIT
Voltage range	EN, FB, PS/SYNC, VIN, VOUT, FB, PG, L2	-0.3	17	V
	L1	-0.3	$V_{IN} + 0.3$	V
	VAUX	-0.3	7.5	V
Operating virtual junction temperature range, $T_J$		-40	150	°C
Storage temperature, $T_{stg}$		-65	150	°C

(1) Stresses beyond those listed under *absolute maximum ratings* may cause permanent damage to the device. These are stress ratings only, and functional operation of the device at these or any other conditions beyond those indicated under *recommended operating conditions* is not implied. Exposure to absolute-maximum-rated conditions for extended periods may affect device reliability.

### 7.2 ESD Ratings

		VALUE	UNIT
$V_{(ESD)}$	Electrostatic discharge	Human-body model (HBM), per ANSI/ESDA/JEDEC JS-001 <sup>(1)</sup>	±3000
		Machine model (MM)	±200
		Charged-device model (CDM), per JEDEC specification JESD22-C101 <sup>(2)</sup>	±1500

(1) JEDEC document JEP155 states that 500-V HBM allows safe manufacturing with a standard ESD control process.

(2) JEDEC document JEP157 states that 250-V CDM allows safe manufacturing with a standard ESD control process.

### 7.3 Recommended Operating Conditions

		MIN	MAX	UNIT
Supply voltage at VIN		2.5	12	V
Output current $I_{OUT}$ <sup>(1)</sup>			1	A
Operating free air temperature range, $T_A$		-40	85	°C
Operating virtual junction temperature range, $T_J$		-40	125	°C

(1)  $10 \leq V_{IN} \leq 12$  V

### 7.4 Thermal Information

THERMAL METRIC <sup>(1)</sup>		TPS63060 TPS63061	UNIT
		DSC	
		10 PINS	
$R_{\theta JA}$	Junction-to-ambient thermal resistance	48.7	°C/W
$R_{\theta JC(top)}$	Junction-to-case (top) thermal resistance	54.8	
$R_{\theta JB}$	Junction-to-board thermal resistance	19.8	
$\Psi_{JT}$	Junction-to-top characterization parameter	1.1	
$\Psi_{JB}$	Junction-to-board characterization parameter	19.6	
$R_{\theta JC(bot)}$	Junction-to-case (bottom) thermal resistance	4.2	

(1) For more information about traditional and new thermal metrics, see the *IC Package Thermal Metrics* application report, [SPRA953](#).

## 7.5 Electrical Characteristics

 over operating free-air temperature range (unless otherwise noted)  $T_A = 25^\circ\text{C}$ 

PARAMETER		TEST CONDITIONS	MIN	TYP	MAX	UNIT	
<b>DC/DC STAGE</b>							
$V_{IN}$	Input voltage range		2.5		12	V	
$V_{IIN}$	Minimum input voltage for startup				2.5	V	
$V_{OUT}$	Output voltage		TPS63060	2.5	8	V	
		$V_{PS/SYNC} = \text{GND}$ Referenced to 5 V	TPS63061	0.6%	5%		
$D_{MIN}$	Minimum duty-cycle in step down conversion			10%	20%		
$V_{FB}$	Feedback voltage	$V_{PS/SYNC} = V_{IN}$	TPS63060	495	500	505	mV
		$V_{PS/SYNC} = \text{GND}$ Referenced to 500 mV		0.6%		5%	
$f_{OSC}$	Oscillator frequency		2200	2400	2600	kHz	
	Frequency range for synchronization		2200	2400	2600	kHz	
$I_{SW}$	Average inductance current limit	$V_{IN} = 5 \text{ V}$	2000	2250	2500	mA	
$R_{DS(on)H}$	High-side MOSFET on-resistance	$V_{IN} = 5 \text{ V}$		90		m $\Omega$	
$R_{DS(on)L}$	Low-side switch MOSFET on-resistance	$V_{IN} = 5 \text{ V}$		95		m $\Omega$	
	Line regulation	Power save mode disabled		0.5%			
	Load regulation	Power save mode disabled		0.5%			
$I_Q$	Input voltage quiescent current	$I_{OUT} = 0 \text{ mA}$ , $V_{EN} = V_{IN} = 5 \text{ V}$ , $V_{OUT} = 5 \text{ V}$		30	60	$\mu\text{A}$	
$I_Q$	Output voltage quiescent current			7	15	$\mu\text{A}$	
$R_{FB}$	FB input impedance	$V_{EN} = \text{HIGH}$	TPS63061	1.5		M $\Omega$	
$I_S$	Shutdown current	$V_{EN} = 0 \text{ V}$ , $V_{IN} = 5 \text{ V}$		0.3	2	$\mu\text{A}$	
<b>CONTROL STAGE</b>							
$V_{AUX}$	Maximum bias voltage	$V_{IN} > V_{OUT}$		$V_{IN}$	7	V	
		$V_{IN} < V_{OUT}$		$V_{OUT}$	7	V	
$I_{AUX}$	Load current at $V_{AUX}$				1	mA	
UVLO	Under voltage lockout threshold	Input voltage falling	1.8	1.9	2.2	V	
	UVLO hysteresis			300		mV	
$V_{IL}$	EN, PS/SYNC input low voltage				0.4	V	
$V_{IH}$	EN, PS/SYNC input high voltage		1.2			V	
	EN, PS/SYNC input current	Clamped on GND or $V_{IN}$		0.01	0.1	$\mu\text{A}$	
	PG output low voltage	$V_{OUT} = 5 \text{ V}$ , $I_{PGL} = 10 \mu\text{A}$		0.04	0.4	V	
	PG output leakage current			0.01	0.1	$\mu\text{A}$	
	Output overvoltage protection		12		16	V	
	Overtemperature protection			140		$^\circ\text{C}$	
	Overtemperature hysteresis			20		$^\circ\text{C}$	

## 7.6 Typical Characteristics

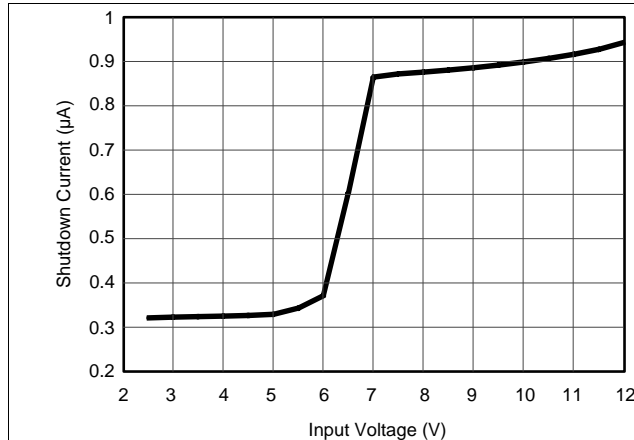

**Figure 1. Shutdown Current vs Input Voltage**

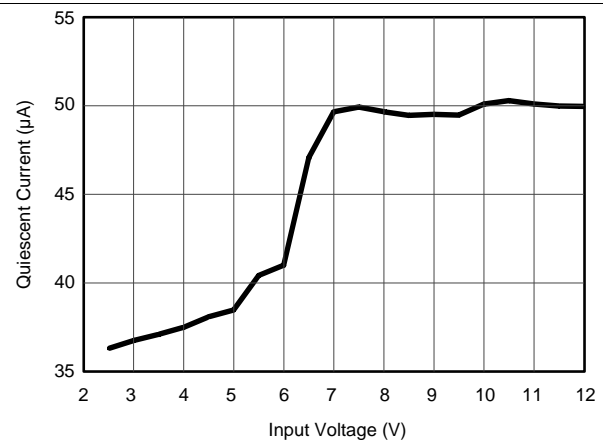

**Figure 2. Quiescent Current vs Input Voltage**

## 8 Detailed Description

### 8.1 Overview

The controller circuit of the device is based on an average current mode topology. The controller also uses input and output voltage feedforward. Changes of input and output voltage are monitored and immediately can change the duty cycle in the modulator to achieve a fast response to those errors. The voltage error amplifier gets its feedback input from the FB pin. At adjustable output voltages, a resistive voltage divider must be connected to that pin. At fixed output voltages, FB must be connected to the output voltage to directly sense the voltage. Fixed output voltage versions use a trimmed internal resistive divider. The device compares the feedback voltage with the internal reference voltage to generate a stable and accurate output voltage.

The device uses four internal N-channel MOSFETs to maintain synchronous power conversion at all possible operating conditions. This enables the device to maintain high efficiency over a wide input voltage and output power range. The device has two separate ground pins (GND and PGND) to avoid ground shift problems due to the high currents in the switches. The reference for all control functions is the GND pin. The power switches are connected to PGND. Both grounds must be connected on the PCB at only one point, ideally, close to the GND pin. Due to the 4-switch topology, the load is always disconnected from the input during shutdown of the converter. An internal temperature sensor protects the device from overheating.

## 8.2 Functional Block Diagrams

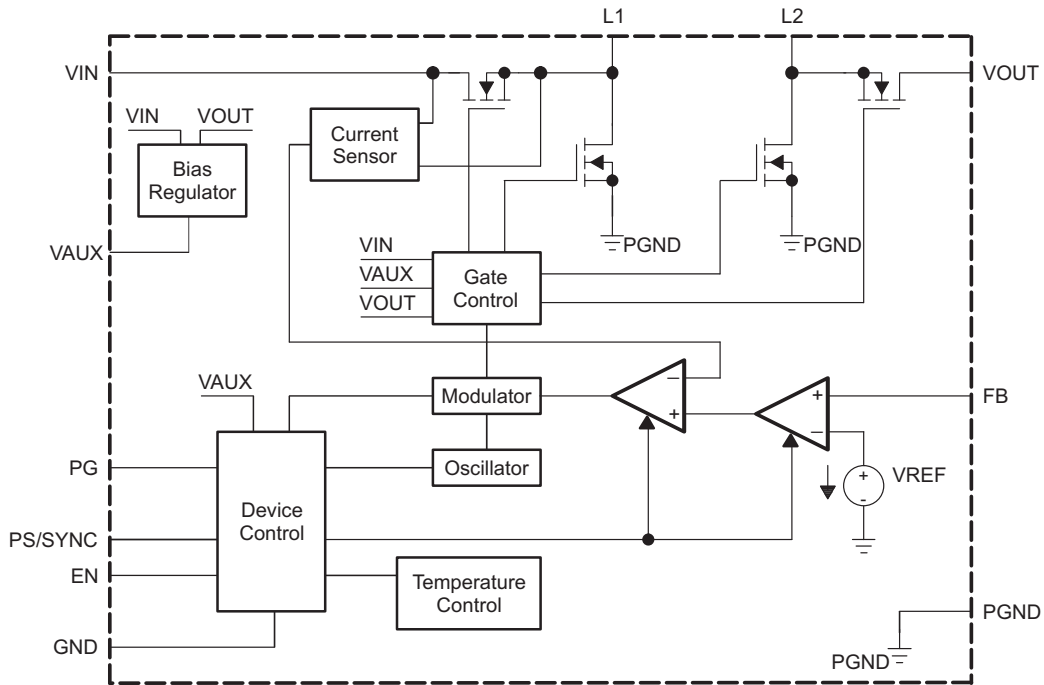

Figure 3. TPS63061 Fixed Output

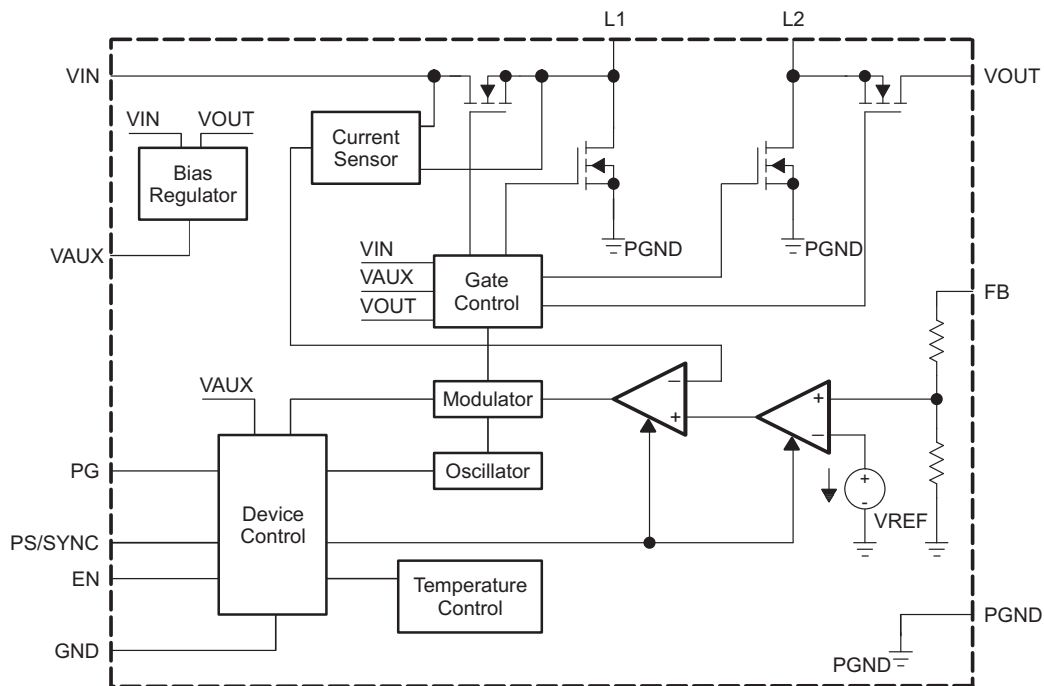

Figure 4. TPS63060 Adjustable

## 8.3 Feature Description

### 8.3.1 Power Good

The device has a built in power good function to indicate whether the output voltage is regulated properly. As soon as the average inductor current gets limited to a value below the current the voltage regulator demands for maintaining the output voltage the power good output gets low impedance. The output is open drain, so its logic function can be adjusted to any voltage level the connected logic is using, by connecting a pull up resistor to the supply voltage of the logic. By monitoring the status of the current control loop, the power good output provides the earliest indication possible for an output voltage break down and leaves the connected application a maximum time to safely react.

### 8.3.2 Soft-Start Function and Short-Circuit Protection

After being enabled, the device starts operating. The average current limit ramps up from an initial 400 mA following the output voltage increasing. At an output voltage of about 1.2 V, the current limit is at its nominal value. If the output voltage does not increase, the current limit does not increase. The device implements no timer. Thus, the output voltage overshoot at startup, as well as the inrush current, remains at a minimum. The device ramps up the output voltage in a controlled manner even if a large capacitor is connected at the output. When the output voltage does not increase above 1.2 V, the device assumes a short circuit at the output, and keeps the current limit low to protect itself and the application. During a short-circuit situation on the output, the device maintains the current limit below 2 A typically (minimum average inductance current).

### 8.3.3 Overvoltage Protection

If, for any reason, the output voltage is not fed back properly to the input of the voltage amplifier, control of the output voltage no longer works. Therefore, overvoltage protection is implemented to avoid the output voltage exceeding critical values for the device and possibly for the system it supplies. The implemented overvoltage protection circuit monitors the output voltage internally as well. If it reaches the overvoltage threshold, the voltage amplifier regulates the output voltage to this value.

### 8.3.4 Undervoltage Lockout

An undervoltage lockout function prevents device start-up if the supply voltage on VIN is lower than approximately its threshold (see the [Electrical Characteristics](#) table). When in operation, the device automatically enters the shutdown mode if the voltage on VIN drops below the undervoltage lockout threshold. The device automatically restarts if the input voltage recovers to the minimum operating input voltage.

### 8.3.5 Overtemperature Protection

The device has a built-in temperature sensor which monitors the internal device temperature. If the temperature exceeds the programmed threshold (see the [Electrical Characteristics](#) table) the device stops operating. As soon as the device temperature has decreased below the programmed threshold, it starts operating again. There is a built-in hysteresis to avoid unstable operation at device temperatures at the overtemperature threshold.

## 8.4 Device Functional Modes

### 8.4.1 Buck-Boost Operation

To regulate the output voltage at all possible input voltage conditions, the device automatically switches from buck operation to boost operation and back as required. It always uses one active switch, one rectifying switch, one switch permanently on, and one switch permanently off. Therefore, it operates as a step down converter (buck) when the input voltage is higher than the output voltage, and as a boost converter when the input voltage is lower than the output voltage. There is no mode of operation in which all 4 switches are permanently switching. Controlling the switches this way allows the converter to maintain high efficiency at the most important point of operation, when the input voltage is close to the output voltage. The RMS current through the switches and the inductor is kept at a minimum, to minimize switching and conduction losses.

### 8.4.2 Control Loop Description

The controller circuit of the device is based on an average current mode topology. The average inductor current is regulated by a fast current regulator loop which is controlled by a voltage control loop. [Figure 5](#) shows the control loop.

Device Functional Modes (continued)

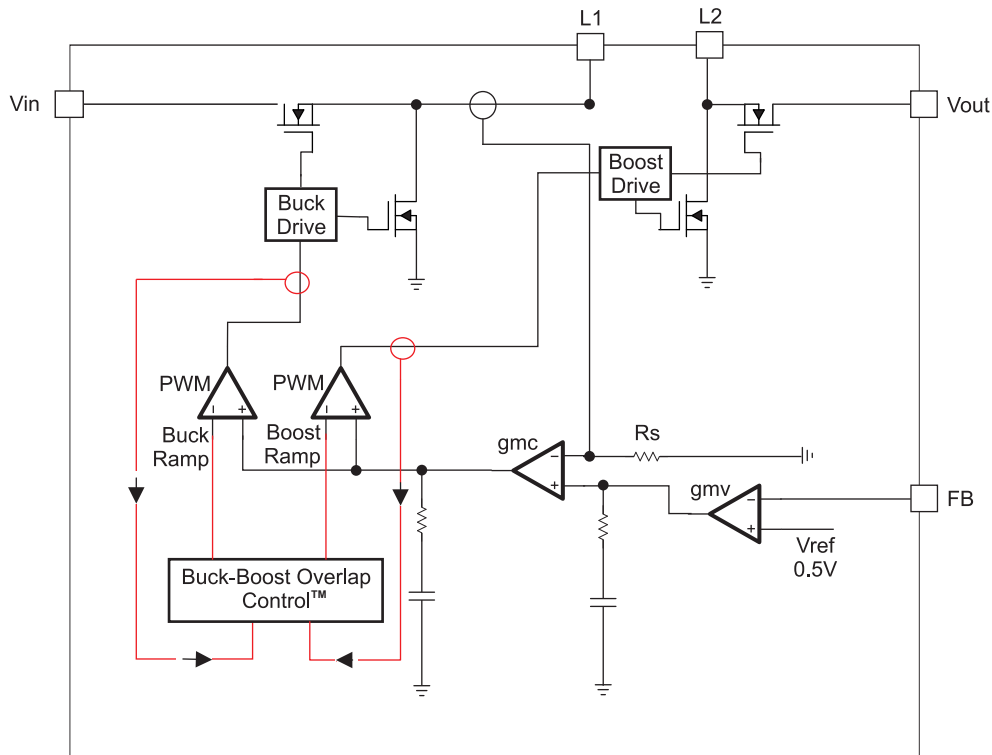

Figure 5. Average Current Mode Control

The non inverting input of the transconductance amplifier,  $g_{MV}$ , is assumed to be constant. The output of  $g_{MV}$  defines the average inductor current. The inductor current is reconstructed by measuring the current through the high side buck MOSFET. This current corresponds exactly to the inductor current in boost mode. In buck mode the current is measured during the on time of the same MOSFET. During the off time, the current is reconstructed internally starting from the peak value at the end of the on-time cycle. The average current is compared to the desired value and the difference, or current error, is amplified and compared to the buck or the boost sawtooth ramp. Depending on which of the two ramps the  $g_{MC}$  amplified output crosses, the device activates either the buck MOSFETs or the boost MOSFETs. When the input voltage is close to the output voltage, one boost cycle always follows a buck cycle. In this condition, no more than three cycles in a row of the same mode are allowed. This control method in the buck-boost region ensures a robust control and the highest efficiency.

## Device Functional Modes (continued)

### 8.4.3 Power-Save Mode and Synchronization

The PS/SYNC pin can be used to select different operation modes. Power save mode improves efficiency at light load. To enable power save mode, PS/SYNC must be set low. The device enters power save mode when the average inductor current falls to a level lower than approximately 100 mA. In that situation, the converter operates with reduced switching frequency and with a minimum quiescent current to maintain high efficiency.

During the power save mode operation, the output voltage is monitored with a comparator by the threshold comp low and comp high. When the device enters power save mode, the converter stops operating and the output voltage drops. The slope of the output voltage depends on the load and the value of output capacitance. As the output voltage falls below the comp low threshold set to 2.5% typical above the output voltage, the device ramps up the output voltage again, by starting operation using a programmed average inductor current higher than required by the current load condition. Operation can last for one or several pulses. The converter continues these pulses until the comp high threshold, set to typically 3.5% above the nominal output voltage, is reached and the average inductor current gets lower than about 100 mA. When the load increases above the minimum forced inductor current of about 100 mA, the device automatically switches to PWM mode.

The power save mode can be disabled by programming the PS/SYNC high. Connecting a clock signal at PS/SYNC forces the device to synchronize to the connected clock frequency.

Synchronization is done by a PLL to lower and higher frequencies compared to the internal clock. The PLL can also tolerate missing clock pulses without the converter malfunctioning. The PS/SYNC input supports standard logic thresholds.

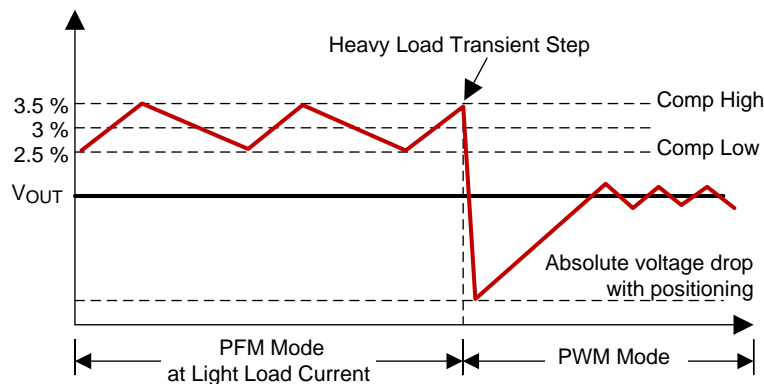

**Figure 6. Power-Save Mode Thresholds and Dynamic Voltage Positioning**

### 8.4.4 Dynamic Voltage Positioning

As shown in Figure 6, the output voltage is typically 3% above the nominal output voltage at light-load currents, as the device is operating in power save mode. This operation mode allows additional headroom for the voltage drop during a load transient from light load to full load. This additional headroom allows the converter to operate with a small output capacitor and maintain a low absolute voltage drop during heavy load transient changes. See Figure 6 for detailed operation of the power save mode operation.

### 8.4.5 Dynamic Current Limit

The dynamic current limit function maintains the output voltage regulation when the power source becomes weaker. The maximum current allowed through the switch depends on the voltage applied at the input terminal of the TPS6306x devices. Figure 7 shows this dependency, and the  $I_{SW}$  vs  $V_{IN}$ . The dynamic current limit has its lowest value when reaching the minimum recommended supply voltage at  $V_{IN}$ .

Given the  $I_{SW}$  value from Figure 7, it is then possible to calculate the output current reached in boost mode using Equation 1 and Equation 2 and in buck mode using Equation 3 and Equation 4.

$$\text{Duty Cycle Boost} \quad D = \frac{V_{OUT} - V_{IN}}{V_{OUT}} \quad (1)$$

$$\text{Maximum Output Current Boost} \quad I_{OUT} = \eta \times I_{SW} \times (1 - D) \quad (2)$$

## Device Functional Modes (continued)

$$\text{Duty Cycle Buck} \quad D = \frac{V_{\text{OUT}}}{V_{\text{IN}}} \quad (3)$$

$$\text{Maximum Output Current Buck} \quad I_{\text{OUT}} = I_{\text{SW}}$$

where

- $\eta$  is the estimated converter efficiency (use the number from the efficiency curves or 0.80 as an assumption)
  - $f$  is the converter switching frequency (typical 2.4 MHz)
  - $L$  is the selected inductor value
- (4)

If the die temperature increases above the recommended maximum temperature, the dynamic current limit becomes active. The current limit is reduced with temperature increasing.

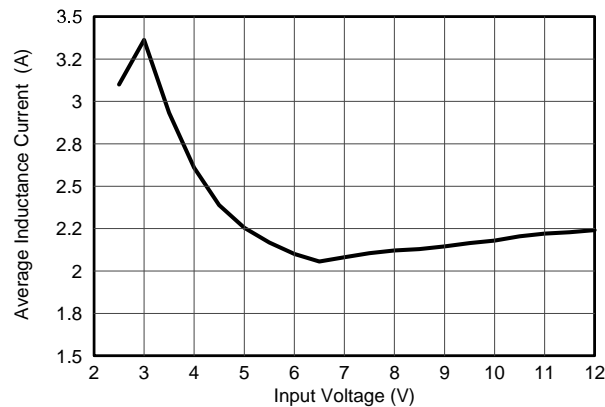

**Figure 7. Average Inductance Current vs Input Voltage**

### 8.4.6 Device Enable

The device operates when EN is set high. The device enters a shutdown sequence when EN is set to GND. During the shutdown sequence, the regulator stops switching, all internal control circuitry is switched off, and the load is disconnected from the input. It is possible for the output voltage to drop below the input voltage during shutdown. During the start-up sequence, the device limits the duty cycle and the peak current in order to avoid high peak currents flowing from the input.

## 9 Application and Implementation

### NOTE

Information in the following applications sections is not part of the TI component specification, and TI does not warrant its accuracy or completeness. TI's customers are responsible for determining suitability of components for their purposes. Customers should validate and test their design implementation to confirm system functionality.

### 9.1 Application Information

The TPS6306x devices provide a power supply solution for products powered by either three-cell up to six-cell alkaline, NiCd or NiMH battery, or a one-cell or dual-cell Li-Ion or Li-polymer battery. Output currents can go as high as 2-A while using a dual-cell Li-Ion or Li-polymer battery, and discharge it down to 5 V or lower.

### 9.2 Typical Application

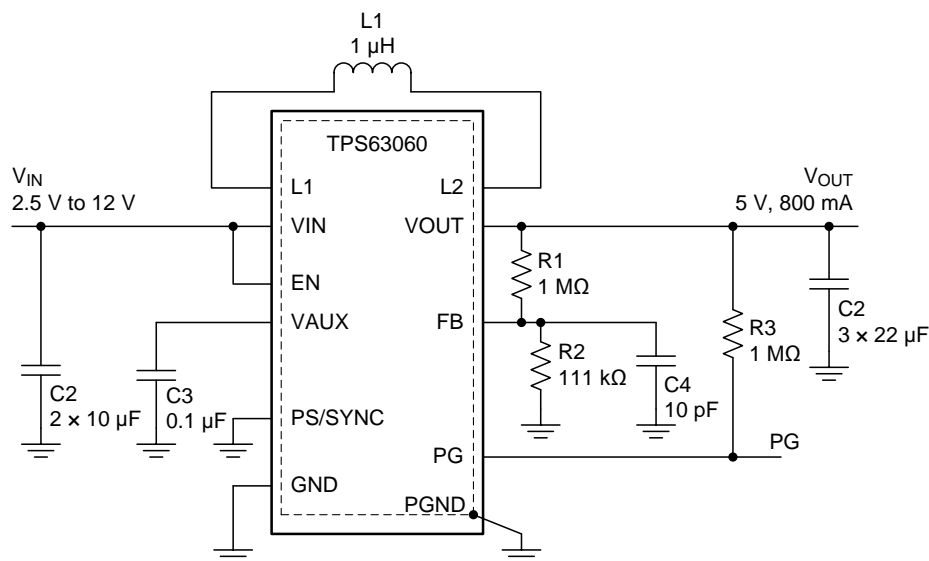

**Figure 8. 5-V Adjustable Buck-Boost Converter Application**

#### 9.2.1 Design Requirements

The design guideline provides a component selection to operate the device within the recommended operating conditions. [Table 1](#) lists the components used in this application.

**Table 1. Components for Application Characteristic Curves**

REFERENCE	DESCRIPTION	MANUFACTURER
	TPS63060 and TPS63061	Texas Instruments
L1	1 µH, 3 mm x 3 mm x 1.5 mm	Coilcraft , XFL4020-102
C1	2 x 10 µF 16V, 0805, X5R ceramic	Taiyo Yuden, EMK212BJ
C2	3 x 22 µF 16V, 0805, X5R ceramic	Taiyo Yuden, LMK212BJ
C3	0.1 µF, X5R ceramic	
C4	10 pF, ceramic	
R1, R2	Depending on the output voltage at TPS63060 and TPS63061: R1=0, C4 and R2 n.a.	

## 9.2.2 Detailed Design Procedure

The first step is the selection of the output filter components. To simplify this process, use [Table 2](#) to compare inductor and capacitor value combinations.

### 9.2.2.1 Step One: Output Filter Design

**Table 2. Output Capacitor and Inductor Combinations**

INDUCTOR VALUE [ $\mu\text{H}$ ] <sup>(1)</sup>	OUTPUT CAPACITOR VALUE [ $\mu\text{F}$ ] <sup>(2)</sup>		
	44	66	100
1.0	√	√ <sup>(3)</sup>	√
1.5	√	√	√

(1) Inductor tolerance and current de-rating is anticipated. The effective inductance can vary by 20% and –30%.

(2) Capacitance tolerance and bias voltage de-rating is anticipated. The effective capacitance can vary by 20% and –50%.

(3) Typical application. Other check mark indicates recommended filter combinations

### 9.2.2.2 Step Two: Inductor Selection

The inductor selection is affected by several parameters including inductor ripple current, output voltage ripple, transition point into power-save mode, and efficiency. See [Table 3](#) for typical inductors.

**Table 3. List of Recommended Inductors**

INDUCTOR VALUE ( $\mu\text{H}$ )	COMPONENT SUPPLIER	SIZE (LxWxH) (mm)	CURRENT SATURATION ( $I_{\text{SAT}}$ ) (A)	DCR (m $\Omega$ )
1	Coilcraft XFL4020-102	4 x 4 x 2.1	5.1	10.8
1	TOKO DEM2815 1226AS-H-1R0N	3 x 3.2 x 1.5	2.7	27
1.5	Coilcraft XFL4020-152	4 x 4 x 2.1	4.4	14.4

For high efficiencies, the inductor should have a low dc resistance to minimize conduction losses. Especially at high-switching frequencies the core material has a higher impact on efficiency. When using small chip inductors, the efficiency is reduced mainly due to higher inductor core losses. This needs to be considered when selecting the appropriate inductor. The inductor value determines the inductor ripple current. The larger the inductor value, the smaller the inductor ripple current and the lower the conduction losses of the converter. Conversely, larger inductor values cause a slower load transient response. To avoid saturation of the inductor, with the chosen inductance value, the peak current for the inductor in steady state operation can be calculated. [Equation 1](#) and [Equation 5](#) show how to calculate the peak current  $I_{\text{PEAK}}$ . Only the equation which defines the switch current in boost mode is reported because this is providing the highest value of current and represents the critical current value for selecting the right inductor.

$$I_{\text{PEAK}} = \frac{I_{\text{OUT}}}{\eta \times (1-D)} + \frac{V_{\text{IN}} \times D}{2 \times f_{\text{SW}} \times L}$$

where

- D is the duty cycle during boost mode operation
- $f_{\text{SW}}$  is the converter switching frequency (typical 2.4 MHz)
- L is the selected inductor value
- $\eta$  is the estimated converter efficiency (use the number from the efficiency curves or 0.80 as an assumption)
- The calculation must be done for the minimum input voltage which is possible to have in boost mode (5)

Calculating the maximum inductor current using the actual operating conditions gives the minimum saturation current of the inductor needed. It's recommended to choose an inductor with a saturation current 20% higher than the value calculated using [Equation 5](#). Possible inductors are listed in [Table 3](#).

### 9.2.2.3 Step Three: Capacitor Selection

#### 9.2.2.3.1 Input Capacitors

To improve transient behavior of the regulator and EMI behavior of the total power supply circuit, this design suggests a minimum input capacitance of 20  $\mu\text{F}$ . Place a ceramic capacitor placed as close as possible to the VIN and PGND pins of the device.

#### 9.2.2.3.2 Output Capacitor

For the output capacitor, use of a small ceramic capacitor placed as close as possible to the VOUT and PGND pins of the device is recommended. If, for any reason, the application requires the use of large capacitors which can not be placed close to the device, use a smaller ceramic capacitor in parallel to the large capacitor. The small capacitor should be placed as close as possible to the VOUT and PGND pins of the device. The recommended typical output capacitor value is 66  $\mu\text{F}$  with a variance as outlined in [Table 1](#).

There is also no upper limit for the output capacitance value. Larger capacitors cause lower output voltage ripple as well as lower output voltage drop during load transients.

When choosing input and output capacitors, it needs to be kept in mind, that the value of capacitance experiences significant losses from their rated value depending on the operating temperature and the operating DC voltage. It is not uncommon for a small surface mount ceramic capacitor to lose 50% and more of its rated capacitance. For this reason, it is important to use a larger value of capacitance or a capacitor with higher voltage rating in order to ensure the required capacitance at the full operating voltage.

#### 9.2.2.3.3 Bypass Capacitor

To make sure that the internal control circuits are supplied with a stable low noise supply voltage, a capacitor is connected between VAUX and GND. Using a ceramic capacitor with a value of 0.1  $\mu\text{F}$  is recommended. The capacitor needs to be placed close to the VAUX pin. The value of this capacitor should not be higher than 0.22  $\mu\text{F}$ .

### 9.2.2.4 Step Four: Setting the Output Voltage

When the adjustable output voltage version TPS63060 is used, the output voltage is set by the external resistor divider. The resistor divider must be connected between VOUT, FB and GND. When the output voltage is regulated properly, the typical value of the voltage at the FB pin is 500mV. The maximum recommended value for the output voltage is 8V. The current through the resistive divider should be about 100 times greater than the current into the FB pin. The typical current into the FB pin is 0.01 $\mu\text{A}$ , and the voltage across the resistor between FB and GND,  $R_2$ , is typically 500 mV. Based on these two values, the recommended value for  $R_2$  should be lower than 500 k $\Omega$ , in order to set the divider current at 3  $\mu\text{A}$  or higher. It is recommended to keep the value for this resistor in the range of 200 k $\Omega$ . From that, the value of the resistor connected between the VOUT pin and the FB pin, ( $R_1$ ) depending on the needed output voltage can be calculated using [Equation 6](#).

$$R_1 = R_2 \times \left( \frac{V_{\text{OUT}}}{V_{\text{FB}}} - 1 \right) \quad (6)$$

Place a small capacitor ( $C_4$ , 10 pF) in parallel with  $R_2$  when using the power save mode and the adjustable version, to provide filtering and improve the efficiency at light load.

9.2.3 Application Curves

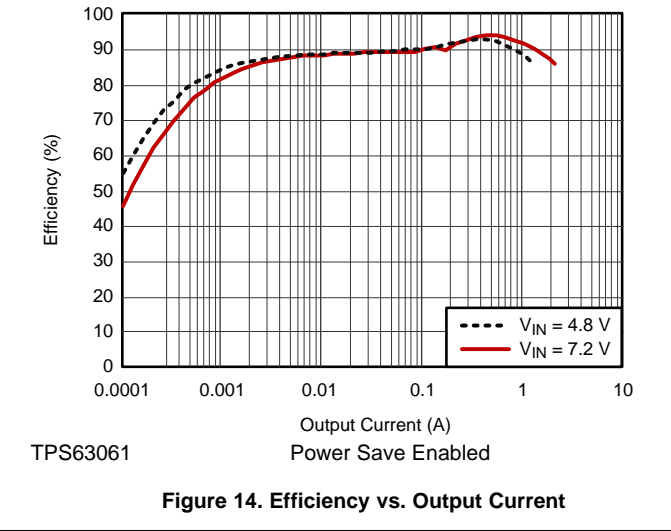
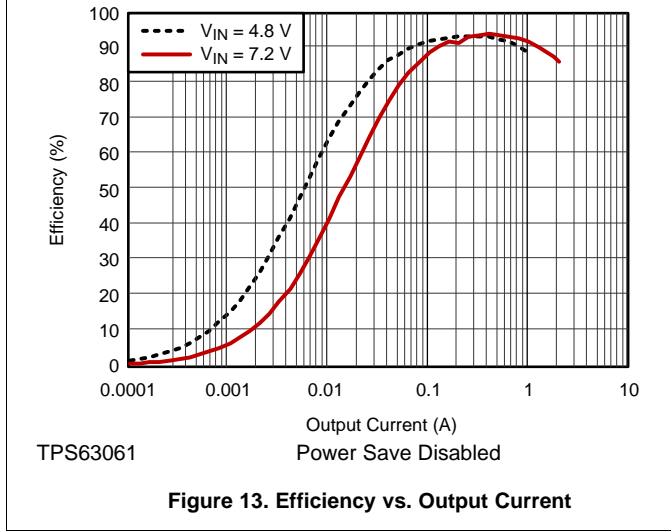
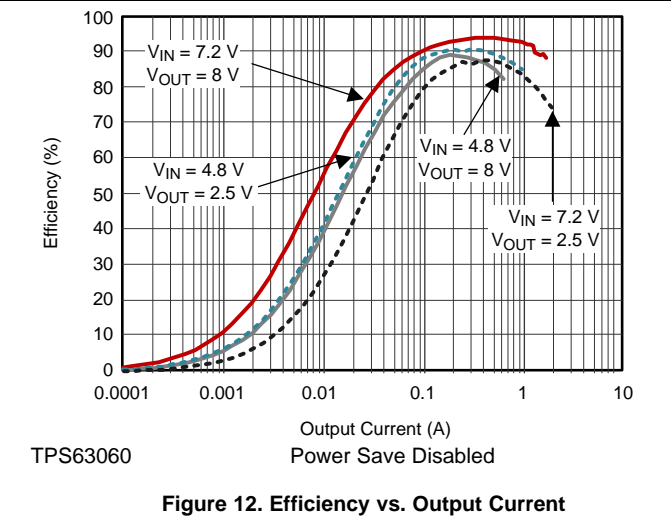
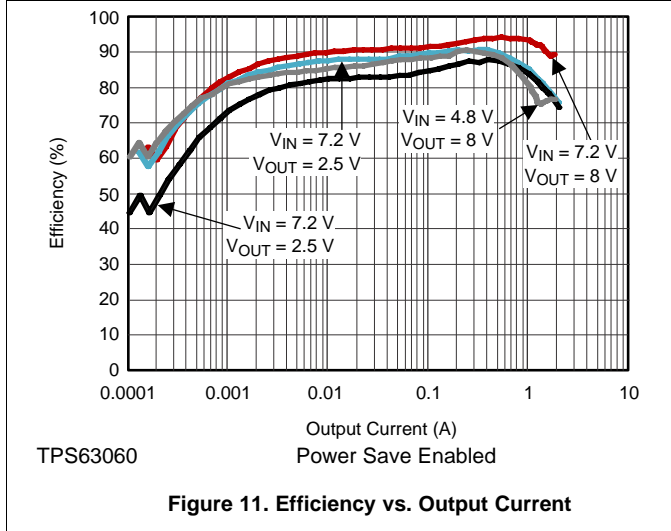
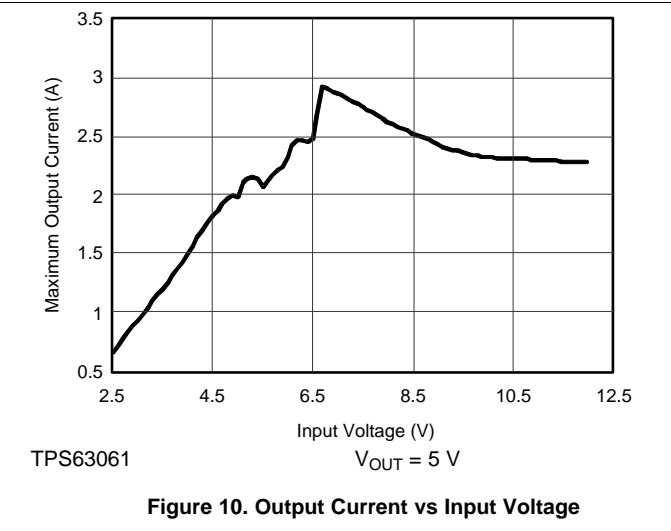
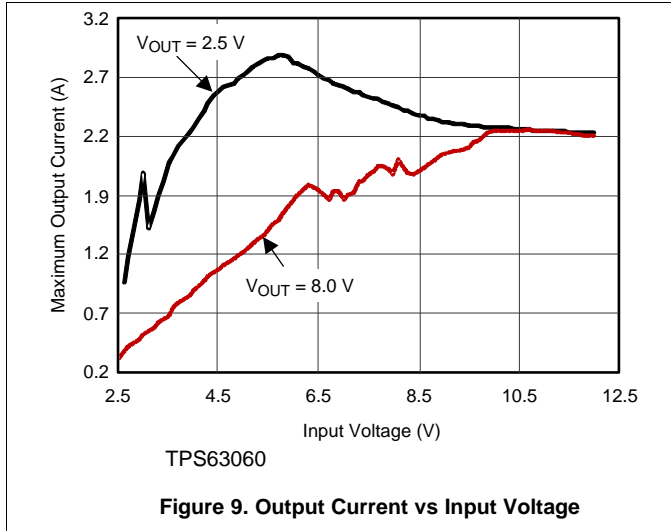

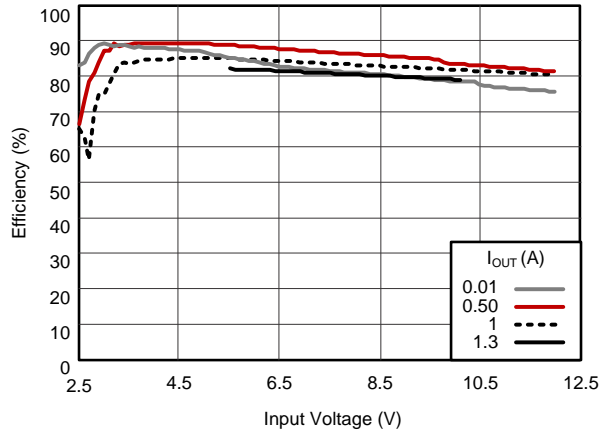

TPS63060  
Power Save Enabled  
 $V_{OUT} = 2.5\text{ V}$

Figure 15. Efficiency vs. Input Voltage

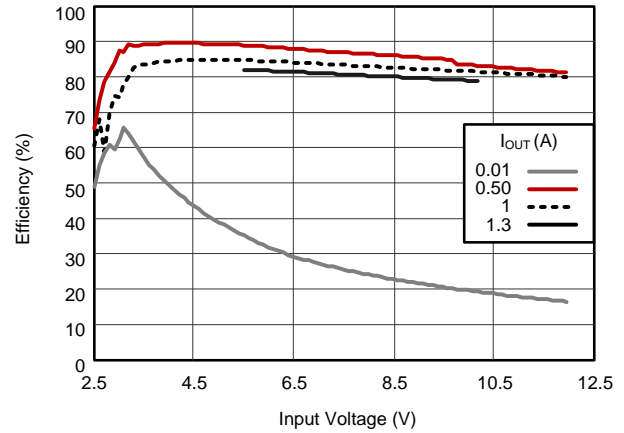

TPS63060  
Power Save Disabled  
 $V_{OUT} = 2.5\text{ V}$

Figure 16. Efficiency vs. Input Voltage

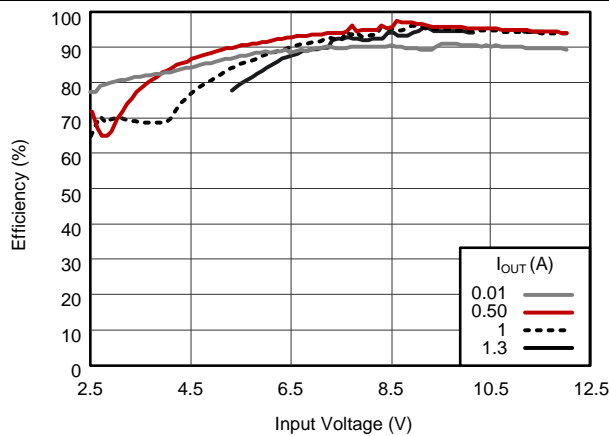

TPS63060  
Power Save Enabled  
 $V_{OUT} = 8\text{ V}$

Figure 17. Efficiency vs. Input Voltage

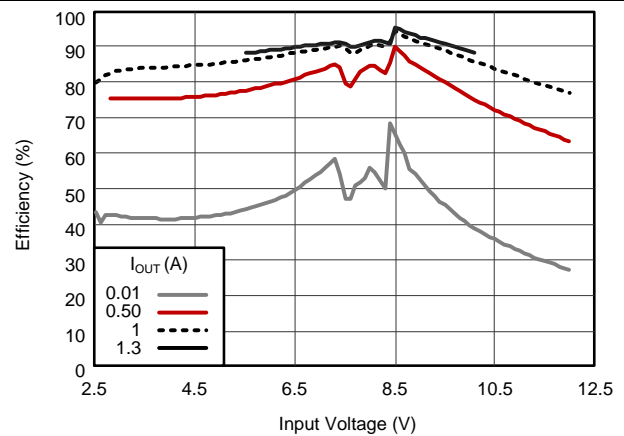

TPS63060  
Power Save Disabled  
 $V_{OUT} = 8\text{ V}$

Figure 18. Efficiency vs. Input Voltage

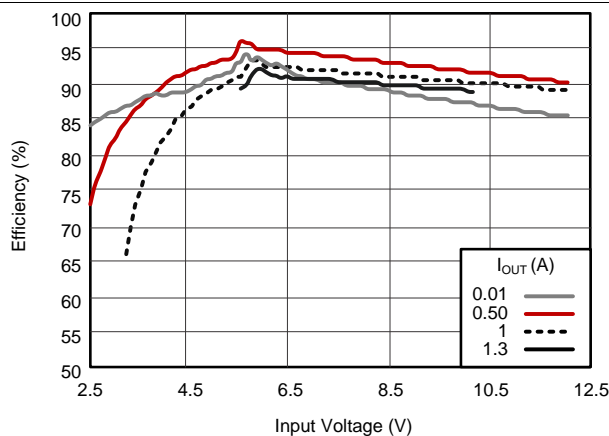

TPS63061  
Power Save Enabled  
 $V_{OUT} = 5\text{ V}$

Figure 19. Efficiency vs. Input Voltage

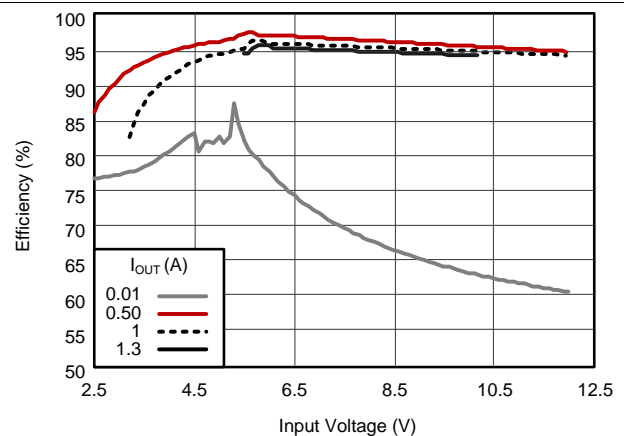

TPS63061  
Power Save Disabled  
 $V_{OUT} = 5\text{ V}$

Figure 20. Efficiency vs. Input Voltage

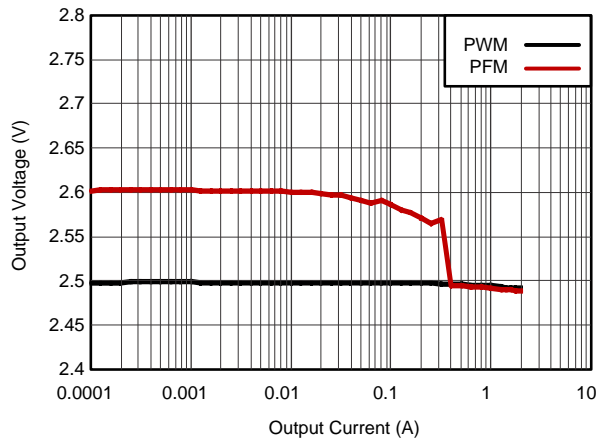

TPS63060  
Power Save Disabled  
 $V_{OUT} = 2.5\text{ V}$   
 $V_{IN} = 7.2\text{ V}$

Figure 21. Output Voltage vs Output Current

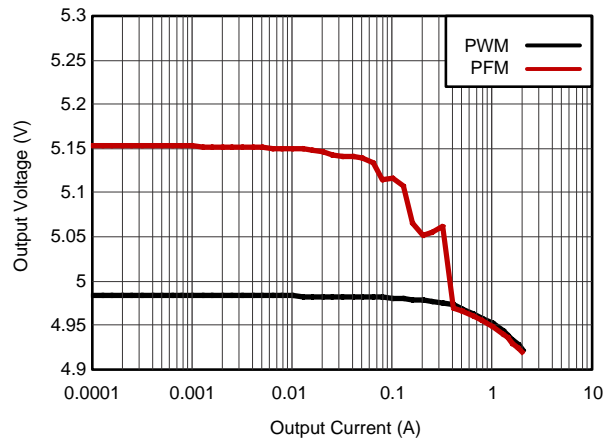

TPS63061  
 $V_{IN} = 7.2\text{ V}$

Figure 22. Output Voltage vs Output Current

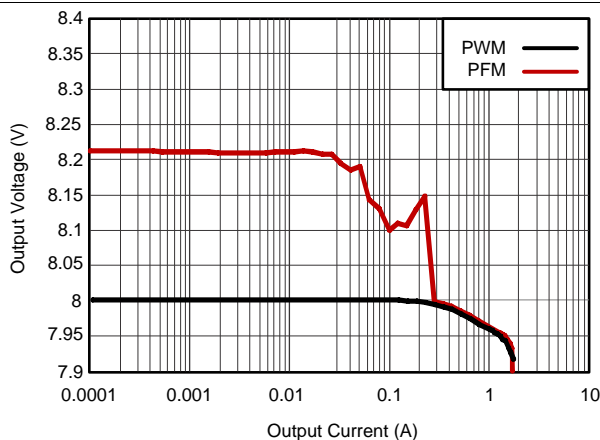

TPS63060  
 $V_{OUT} = 8\text{ V}$   
 $V_{IN} = 7.2\text{ V}$

Figure 23. Output Voltage vs Output Current

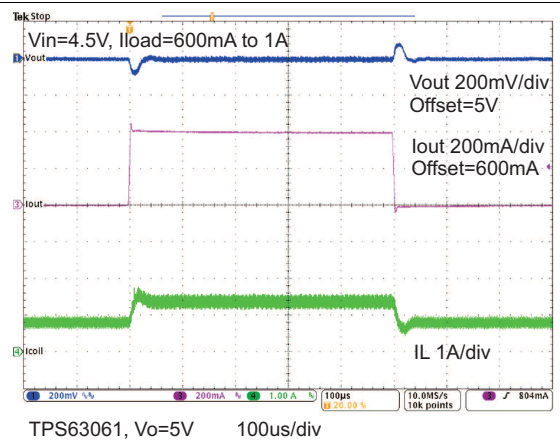

TPS63061,  $V_o=5\text{ V}$  100us/div

Figure 24. Load Transient Response

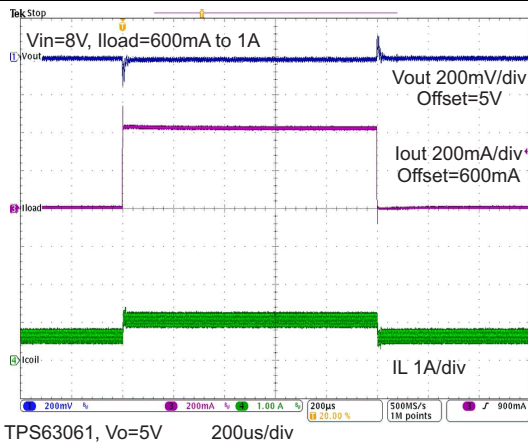

TPS63061,  $V_o=5\text{ V}$  200us/div

Figure 25. Load Transient Response

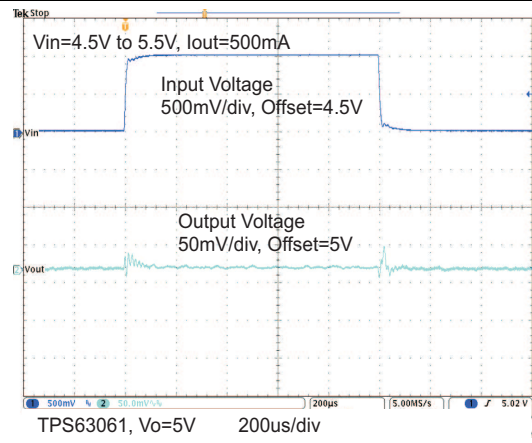

TPS63061,  $V_o=5\text{ V}$  200us/div

Figure 26. Line Transient Response

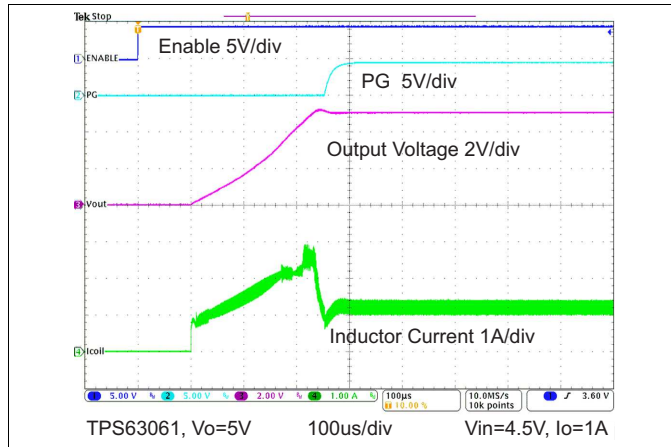

Figure 27. Startup After Enable

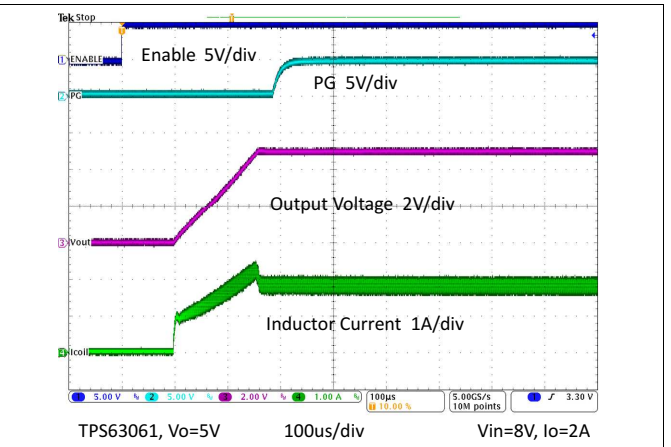

Figure 28. Startup After Enable

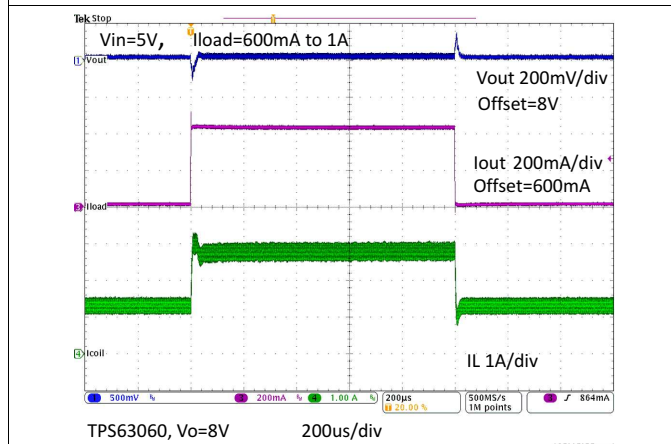

Figure 29. Load Transient

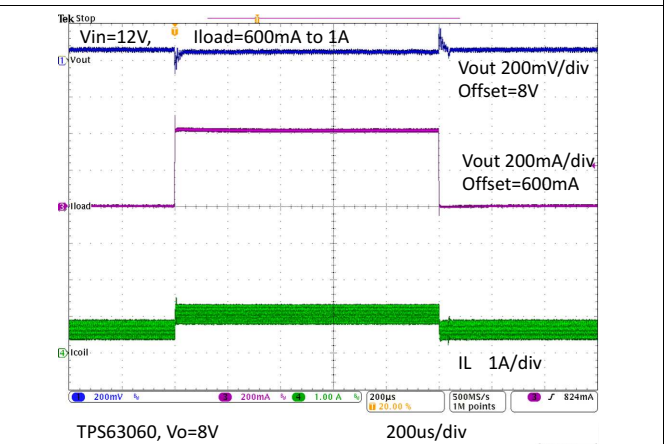

Figure 30. Load Transient

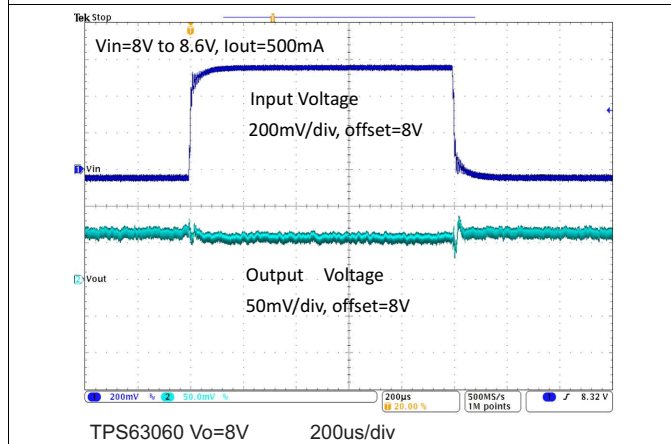

Figure 31. Line Transient

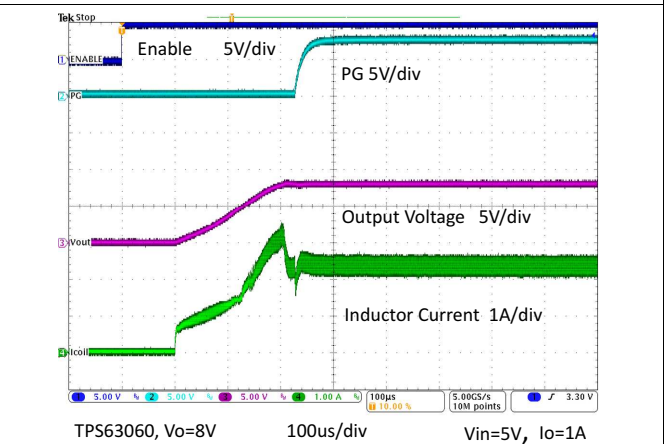
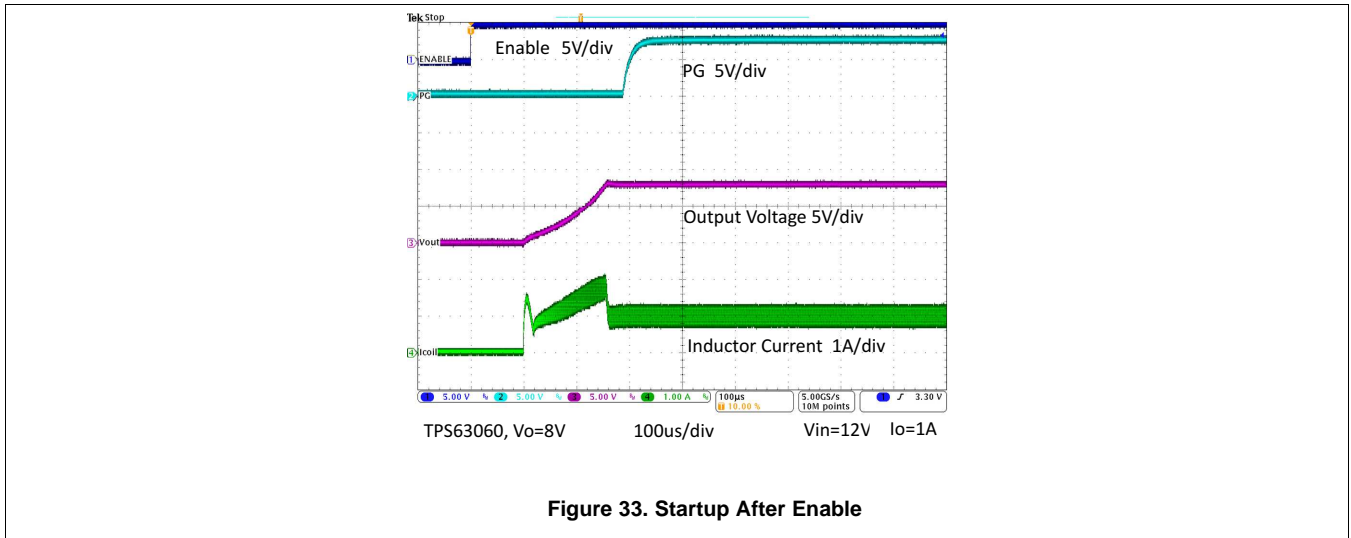

Figure 32. Startup After Enable



## 10 Power Supply Recommendations

The TPS6306x device family has no special requirements for its input power supply. The input supply output current must be rated according to the supply voltage, output voltage and output current of the TPS6306x.

## 11 Layout

### 11.1 Layout Guidelines

For all switching power supplies, the layout is an important step in the design, especially at high peak currents and high switching frequencies. If the layout is not carefully done, the regulator could show stability problems as well as EMI problems. Therefore, use wide and short traces for the main current path and for the power ground tracks. The input capacitor, output capacitor, and the inductor should be placed as close as possible to the device. Use a common ground node for power ground and a different one for control ground to minimize the effects of ground noise. Connect these ground nodes at any place close to one of the ground pins of the device.

The feedback divider should be placed as close as possible to the control ground pin of the device. To lay out the control ground, short traces are recommended as well, separation from the power ground traces. This avoids ground shift problems, which can occur due to superimposition of power ground current and control ground current.

### 11.2 Layout Example

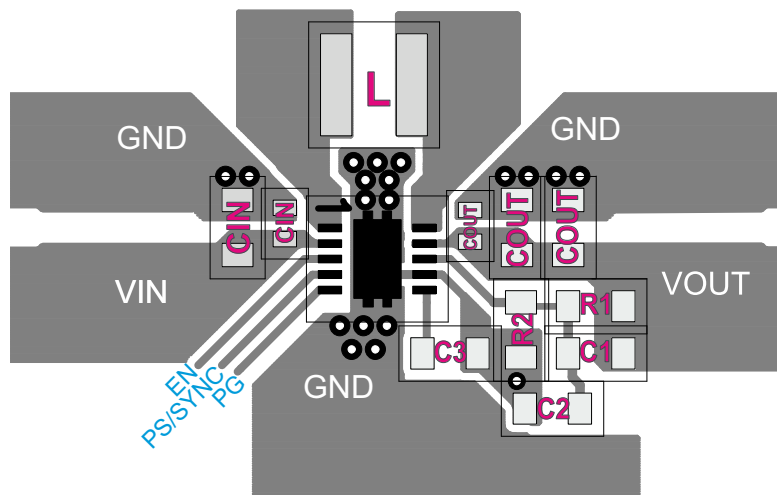

Figure 34. TPS6306x Layout

## 12 Device and Documentation Support

### 12.1 Device Support

#### 12.1.1 Third-Party Products Disclaimer

TI'S PUBLICATION OF INFORMATION REGARDING THIRD-PARTY PRODUCTS OR SERVICES DOES NOT CONSTITUTE AN ENDORSEMENT REGARDING THE SUITABILITY OF SUCH PRODUCTS OR SERVICES OR A WARRANTY, REPRESENTATION OR ENDORSEMENT OF SUCH PRODUCTS OR SERVICES, EITHER ALONE OR IN COMBINATION WITH ANY TI PRODUCT OR SERVICE.

#### 12.1.2 Development Support

- TPS63060EVM-619 2.25-A, Buck-Boost Converter Evaluation Module (click [here](#))
- TPS63060EVM-619 Gerber Files ([SLVC409](#))
- TPS63060 PSpice Transient Model ([SLVM477](#))

### 12.2 Documentation Support

#### 12.2.1 Related Documentation

For related documentation see the following:

- Design Calculations for Buck-Boost Converters ([SLVA535](#))
- Extending the Soft-Start Time in the TPS63010 Buck-Boost Converter ([SLVA553](#))
- Different Methods to Drive LEDs Using TPS63xxx Buck-Boost Converters ([SLVA419](#))

### 12.3 Related Links

[Table 4](#) lists quick access links. Categories include technical documents, support and community resources, tools and software, and quick access to sample or buy.

**Table 4. Related Links**

PARTS	PRODUCT FOLDER	SAMPLE & BUY	TECHNICAL DOCUMENTS	TOOLS & SOFTWARE	SUPPORT & COMMUNITY
TPS63060	<a href="#">Click here</a>	<a href="#">Click here</a>	<a href="#">Click here</a>	<a href="#">Click here</a>	<a href="#">Click here</a>
TPS63061	<a href="#">Click here</a>	<a href="#">Click here</a>	<a href="#">Click here</a>	<a href="#">Click here</a>	<a href="#">Click here</a>

### 12.4 Trademarks

Buck-Boost Overlap Control, PowerPAD are trademarks of Texas Instruments. All other trademarks are the property of their respective owners.

### 12.5 Electrostatic Discharge Caution



These devices have limited built-in ESD protection. The leads should be shorted together or the device placed in conductive foam during storage or handling to prevent electrostatic damage to the MOS gates.

### 12.6 Glossary

[SLYZ022](#) — *TI Glossary*.

This glossary lists and explains terms, acronyms, and definitions.

## 13 Mechanical, Packaging, and Orderable Information

The following pages include mechanical, packaging, and orderable information. This information is the most current data available for the designated devices. This data is subject to change without notice and revision of this document. For browser-based versions of this data sheet, refer to the left-hand navigation.

**PACKAGING INFORMATION**

Orderable Device	Status (1)	Package Type	Package Drawing	Pins	Package Qty	Eco Plan (2)	Lead/Ball Finish (6)	MSL Peak Temp (3)	Op Temp (°C)	Device Marking (4/5)	Samples
TPS63060DSCR	ACTIVE	WSON	DSC	10	3000	Green (RoHS & no Sb/Br)	CU NIPDAU   CU NIPDAUAG	Level-2-260C-1 YEAR	-40 to 85	QUJ	<a href="#">Samples</a>
TPS63060DSCT	ACTIVE	WSON	DSC	10	250	Green (RoHS & no Sb/Br)	CU NIPDAU   CU NIPDAUAG	Level-2-260C-1 YEAR	-40 to 85	QUJ	<a href="#">Samples</a>
TPS63061DSCR	ACTIVE	WSON	DSC	10	3000	Green (RoHS & no Sb/Br)	CU NIPDAU   CU NIPDAUAG	Level-2-260C-1 YEAR	-40 to 85	QUK	<a href="#">Samples</a>
TPS63061DSCT	ACTIVE	WSON	DSC	10	250	Green (RoHS & no Sb/Br)	CU NIPDAU   CU NIPDAUAG	Level-2-260C-1 YEAR	-40 to 85	QUK	<a href="#">Samples</a>

(1) The marketing status values are defined as follows:

**ACTIVE:** Product device recommended for new designs.

**LIFEBUY:** TI has announced that the device will be discontinued, and a lifetime-buy period is in effect.

**NRND:** Not recommended for new designs. Device is in production to support existing customers, but TI does not recommend using this part in a new design.

**PREVIEW:** Device has been announced but is not in production. Samples may or may not be available.

**OBSOLETE:** TI has discontinued the production of the device.

(2) Eco Plan - The planned eco-friendly classification: Pb-Free (RoHS), Pb-Free (RoHS Exempt), or Green (RoHS & no Sb/Br) - please check <http://www.ti.com/productcontent> for the latest availability information and additional product content details.

**TBD:** The Pb-Free/Green conversion plan has not been defined.

**Pb-Free (RoHS):** TI's terms "Lead-Free" or "Pb-Free" mean semiconductor products that are compatible with the current RoHS requirements for all 6 substances, including the requirement that lead not exceed 0.1% by weight in homogeneous materials. Where designed to be soldered at high temperatures, TI Pb-Free products are suitable for use in specified lead-free processes.

**Pb-Free (RoHS Exempt):** This component has a RoHS exemption for either 1) lead-based flip-chip solder bumps used between the die and package, or 2) lead-based die adhesive used between the die and leadframe. The component is otherwise considered Pb-Free (RoHS compatible) as defined above.

**Green (RoHS & no Sb/Br):** TI defines "Green" to mean Pb-Free (RoHS compatible), and free of Bromine (Br) and Antimony (Sb) based flame retardants (Br or Sb do not exceed 0.1% by weight in homogeneous material)

(3) MSL, Peak Temp. - The Moisture Sensitivity Level rating according to the JEDEC industry standard classifications, and peak solder temperature.

(4) There may be additional marking, which relates to the logo, the lot trace code information, or the environmental category on the device.

(5) Multiple Device Markings will be inside parentheses. Only one Device Marking contained in parentheses and separated by a "~" will appear on a device. If a line is indented then it is a continuation of the previous line and the two combined represent the entire Device Marking for that device.

(6) Lead/Ball Finish - Orderable Devices may have multiple material finish options. Finish options are separated by a vertical ruled line. Lead/Ball Finish values may wrap to two lines if the finish value exceeds the maximum column width.

**Important Information and Disclaimer:** The information provided on this page represents TI's knowledge and belief as of the date that it is provided. TI bases its knowledge and belief on information provided by third parties, and makes no representation or warranty as to the accuracy of such information. Efforts are underway to better integrate information from third parties. TI has taken and continues to take reasonable steps to provide representative and accurate information but may not have conducted destructive testing or chemical analysis on incoming materials and chemicals. TI and TI suppliers consider certain information to be proprietary, and thus CAS numbers and other limited information may not be available for release.

In no event shall TI's liability arising out of such information exceed the total purchase price of the TI part(s) at issue in this document sold by TI to Customer on an annual basis.

**OTHER QUALIFIED VERSIONS OF TPS63060 :**

- Enhanced Product: [TPS63060-EP](#)

NOTE: Qualified Version Definitions:

- Enhanced Product - Supports Defense, Aerospace and Medical Applications

**TAPE AND REEL INFORMATION**

**QUADRANT ASSIGNMENTS FOR PIN 1 ORIENTATION IN TAPE**

\*All dimensions are nominal

Device	Package Type	Package Drawing	Pins	SPQ	Reel Diameter (mm)	Reel Width W1 (mm)	A0 (mm)	B0 (mm)	K0 (mm)	P1 (mm)	W (mm)	Pin1 Quadrant
TPS63060DSCR	WSON	DSC	10	3000	330.0	12.4	3.3	3.3	1.1	8.0	12.0	Q2
TPS63060DSCR	WSON	DSC	10	3000	330.0	12.4	3.3	3.3	1.1	8.0	12.0	Q2
TPS63060DSCT	WSON	DSC	10	250	180.0	12.5	3.3	3.3	1.1	8.0	12.0	Q2
TPS63061DSCR	WSON	DSC	10	3000	330.0	12.4	3.3	3.3	1.1	8.0	12.0	Q2
TPS63061DSCT	WSON	DSC	10	250	180.0	12.5	3.3	3.3	1.1	8.0	12.0	Q2

**TAPE AND REEL BOX DIMENSIONS**

\*All dimensions are nominal

Device	Package Type	Package Drawing	Pins	SPQ	Length (mm)	Width (mm)	Height (mm)
TPS63060DSCR	WSON	DSC	10	3000	338.0	355.0	50.0
TPS63060DSCR	WSON	DSC	10	3000	367.0	367.0	35.0
TPS63060DSCT	WSON	DSC	10	250	205.0	200.0	33.0
TPS63061DSCR	WSON	DSC	10	3000	338.0	355.0	50.0
TPS63061DSCT	WSON	DSC	10	250	205.0	200.0	33.0

## GENERIC PACKAGE VIEW

DSC 10

WSON - 0.8 mm max height

PLASTIC SMALL OUTLINE - NO LEAD

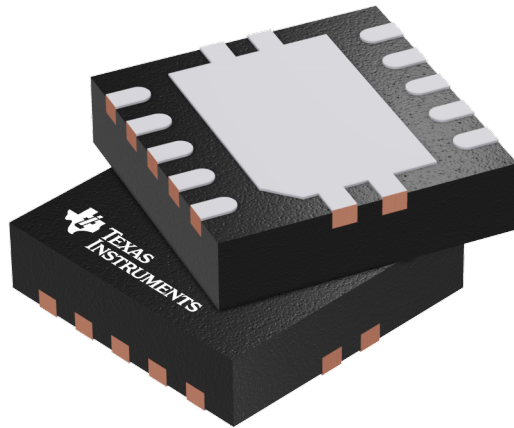

Images above are just a representation of the package family, actual package may vary.  
Refer to the product data sheet for package details.

4207383/F

DSC (S-PWSON-N10)

PLASTIC SMALL OUTLINE NO-LEAD

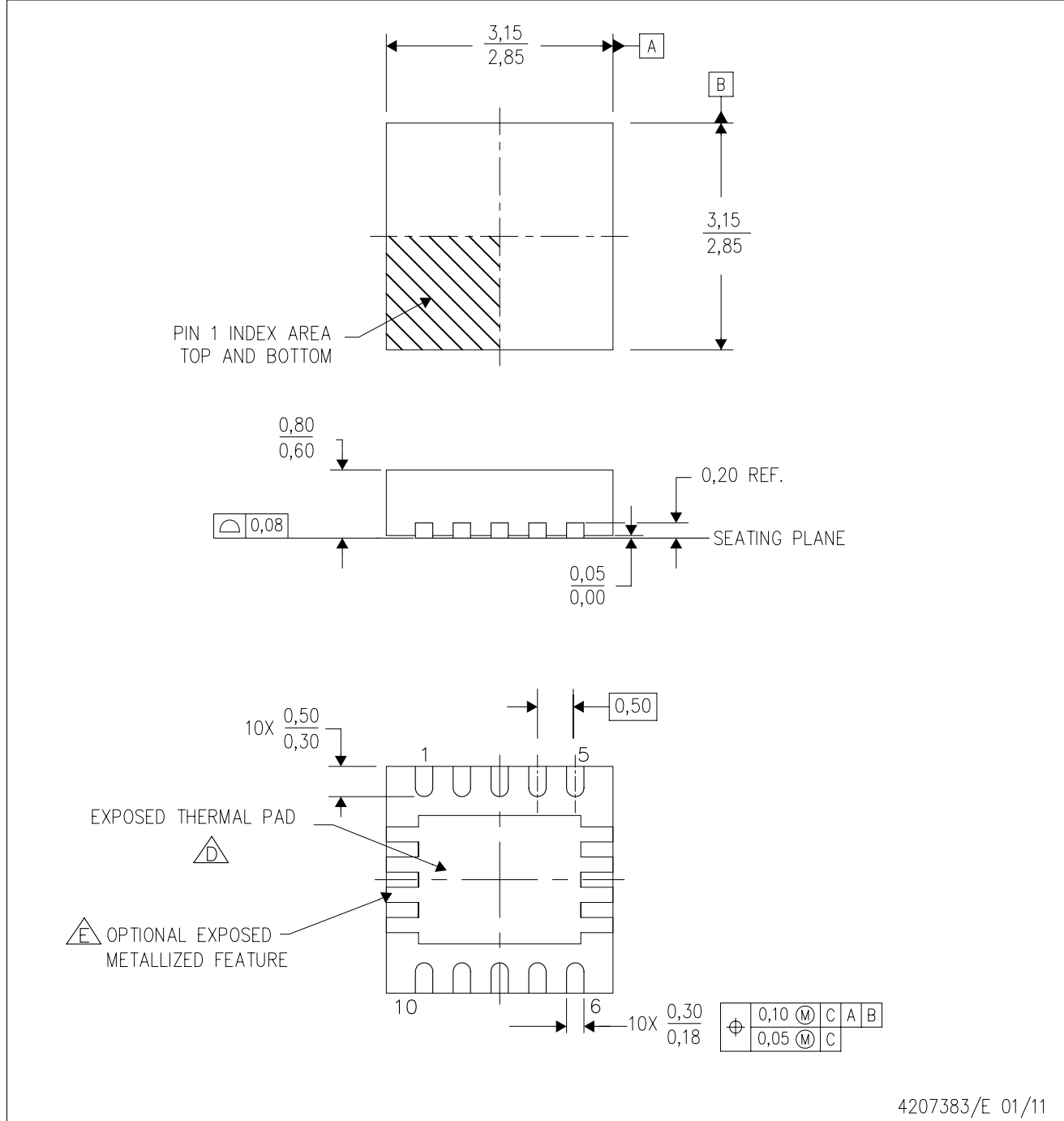

- NOTES:
- A. All linear dimensions are in millimeters. Dimensioning and tolerancing per ASME Y14.5M-1994.
  - B. This drawing is subject to change without notice.
  - C. Small Outline No-Lead (SON) package configuration.
  - D. The package thermal pad must be soldered to the board for thermal and mechanical performance.
  - E. See the Product Data Sheet for details regarding the exposed thermal pad features and dimensions.

# THERMAL PAD MECHANICAL DATA

DSC (S-PWSON-N10)

PLASTIC SMALL OUTLINE NO-LEAD

## THERMAL INFORMATION

This package incorporates an exposed thermal pad that is designed to be attached directly to an external heatsink. The thermal pad must be soldered directly to the printed circuit board (PCB). After soldering, the PCB can be used as a heatsink. In addition, through the use of thermal vias, the thermal pad can be attached directly to the appropriate copper plane shown in the electrical schematic for the device, or alternatively, can be attached to a special heatsink structure designed into the PCB. This design optimizes the heat transfer from the integrated circuit (IC).

For information on the Quad Flatpack No-Lead (QFN) package and its advantages, refer to Application Report, QFN/SON PCB Attachment, Texas Instruments Literature No. SLUA271. This document is available at [www.ti.com](http://www.ti.com).

The exposed thermal pad dimensions for this package are shown in the following illustration.

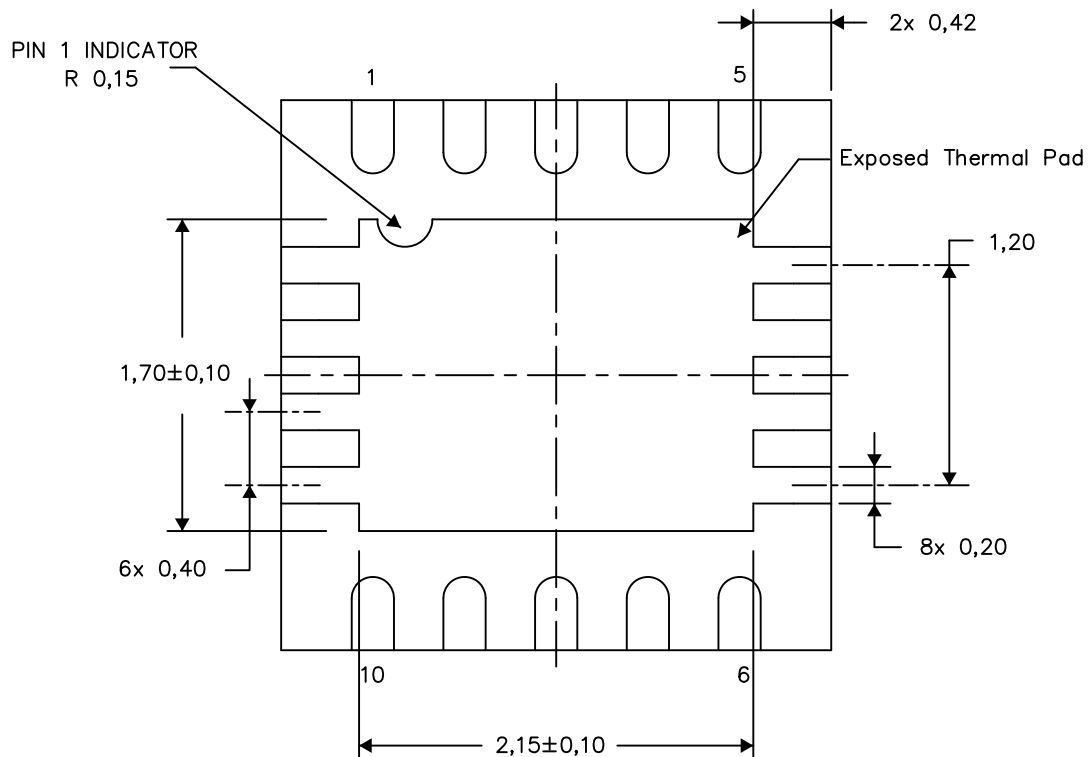

Bottom View

Exposed Thermal Pad Dimensions

4210391-5/Q 08/15

NOTE: A. All linear dimensions are in millimeters

DSC (S-PWSON-N10)

PLASTIC SMALL OUTLINE NO-LEAD

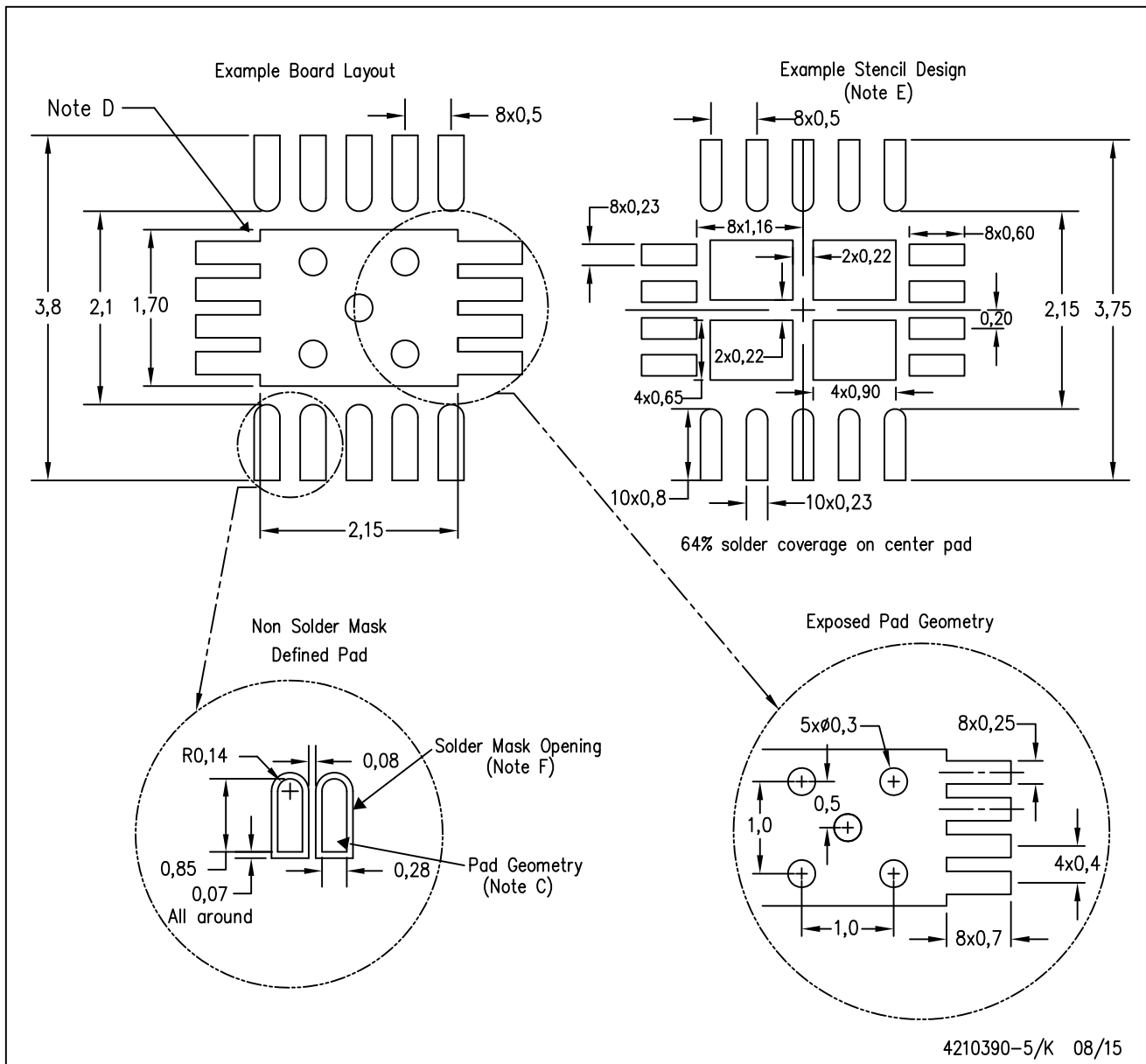

- NOTES:
- All linear dimensions are in millimeters.
  - This drawing is subject to change without notice.
  - Publication IPC-7351 is recommended for alternate designs.
  - This package is designed to be soldered to a thermal pad on the board. Refer to Application Note, Quad Flat-Pack Packages, Texas Instruments Literature No. SLUA271, and also the Product Data Sheets for specific thermal information, via requirements, and recommended board layout. These documents are available at [www.ti.com](http://www.ti.com) <<http://www.ti.com>>.
  - Laser cutting apertures with trapezoidal walls and also rounding corners will offer better paste release. Customers should contact their board assembly site for stencil design recommendations. Refer to IPC 7525 for stencil design considerations.
  - Customers should contact their board fabrication site for minimum solder mask web tolerances between signal pads.

## IMPORTANT NOTICE AND DISCLAIMER

TI PROVIDES TECHNICAL AND RELIABILITY DATA (INCLUDING DATASHEETS), DESIGN RESOURCES (INCLUDING REFERENCE DESIGNS), APPLICATION OR OTHER DESIGN ADVICE, WEB TOOLS, SAFETY INFORMATION, AND OTHER RESOURCES "AS IS" AND WITH ALL FAULTS, AND DISCLAIMS ALL WARRANTIES, EXPRESS AND IMPLIED, INCLUDING WITHOUT LIMITATION ANY IMPLIED WARRANTIES OF MERCHANTABILITY, FITNESS FOR A PARTICULAR PURPOSE OR NON-INFRINGEMENT OF THIRD PARTY INTELLECTUAL PROPERTY RIGHTS.

These resources are intended for skilled developers designing with TI products. You are solely responsible for (1) selecting the appropriate TI products for your application, (2) designing, validating and testing your application, and (3) ensuring your application meets applicable standards, and any other safety, security, or other requirements. These resources are subject to change without notice. TI grants you permission to use these resources only for development of an application that uses the TI products described in the resource. Other reproduction and display of these resources is prohibited. No license is granted to any other TI intellectual property right or to any third party intellectual property right. TI disclaims responsibility for, and you will fully indemnify TI and its representatives against, any claims, damages, costs, losses, and liabilities arising out of your use of these resources.

TI's products are provided subject to TI's Terms of Sale ([www.ti.com/legal/termsofsale.html](http://www.ti.com/legal/termsofsale.html)) or other applicable terms available either on [ti.com](http://ti.com) or provided in conjunction with such TI products. TI's provision of these resources does not expand or otherwise alter TI's applicable warranties or warranty disclaimers for TI products.

Mailing Address: Texas Instruments, Post Office Box 655303, Dallas, Texas 75265  
Copyright © 2019, Texas Instruments Incorporated

## Looking for pricing, stock, or lifecycle information?

Click below to explore more details on WIN SOURCE:

 [View TPS63061DSCT on WIN SOURCE](#)

 [Texas Instruments](#) Information

## Optimize Your Supply Chain with WIN SOURCE Solutions

-  Global Sourcing Solution
-  Obsolete Management
-  Cost Control Management
-  Shortage Management
-  Alternative Solution
-  Excess Inventory Management