



**THE DATASHEET OF  
TPS75003RHLT**



## TPS75003 Configurable Multirail PMIC

### 1 Features

- Two 95% Efficient, 3A Buck Controllers and One 300mA LDO
- Tested and Endorsed by Xilinx for Powering the Spartan™-3, Spartan-3E and Spartan-3L FPGAs
- Adjustable (1.2V to 6.5V for Bucks, 1.0V to 6.5V for LDO) Output Voltages on All Channels
- Input Voltage Range: 2.2V to 6.5V
- Independent Soft-Start for Each Supply
- Independent Enable for Each Supply for Flexible Sequencing
- LDO Stable with 2.2 $\mu$ F Ceramic Output Capacitor
- Small, Low-Profile 4.5mm  $\times$  3.5mm  $\times$  0.9mm VQFN Package

### 2 Applications

- FPGA, DSP, and ASIC Supplies
- Set-Top Boxes
- DSL Modems
- Plasma TV Display Panels

### 3 Description

The TPS75003 is a complete power management solution for FPGA, DSP and other multi-supply applications. The device has been tested with and meets all of the Xilinx Spartan-3, Spartan-3E, and Spartan-3L start-up profile requirements, including monotonic voltage ramp and minimum voltage-rail rise time. Independent enables for each output allow sequencing to minimize demand on the power supply at start-up. Soft-start on each supply limits inrush current during start-up. Two integrated buck controllers allow efficient, cost-effective voltage conversion for both low and high current supplies such as core and I/O. A 300-mA LDO is integrated to provide an auxiliary rail such as  $V_{CCAUX}$  on the Xilinx Spartan-3 FPGA. All three output voltages are externally configurable for maximum flexibility.

The TPS75003 is fully specified from  $-40^{\circ}\text{C}$  to  $+85^{\circ}\text{C}$  and is offered in a VQFN package, yielding a highly compact total solution size with high power dissipation capability.

#### Device Information<sup>(1)</sup>

PART NUMBER	PACKAGE	BODY SIZE (NOM)
TPS75003	VQFN (20)	4.50 mm $\times$ 3.50 mm

(1) For all available packages, see the orderable addendum at the end of the data sheet.

#### Typical Application Schematic

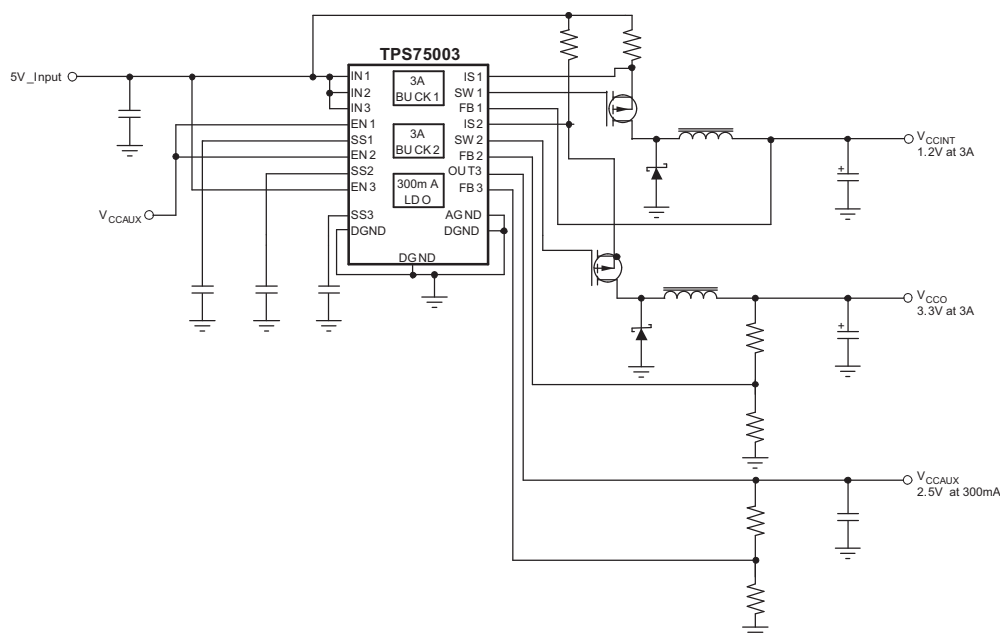

## Table of Contents

<b>1</b>	<b>Features</b> .....	<b>1</b>	<b>8</b>	<b>Application and Implementation</b> .....	<b>15</b>
<b>2</b>	<b>Applications</b> .....	<b>1</b>	8.1	Application Information.....	15
<b>3</b>	<b>Description</b> .....	<b>1</b>	8.2	Typical Application .....	16
<b>4</b>	<b>Revision History</b> .....	<b>2</b>	<b>9</b>	<b>Power Supply Recommendations</b> .....	<b>22</b>
<b>5</b>	<b>Pin Configuration and Functions</b> .....	<b>3</b>	<b>10</b>	<b>Layout</b> .....	<b>23</b>
<b>6</b>	<b>Specifications</b> .....	<b>4</b>	10.1	Layout Guidelines .....	23
6.1	Absolute Maximum Ratings .....	4	10.2	Layout Example .....	24
6.2	ESD Ratings.....	4	<b>11</b>	<b>Device and Documentation Support</b> .....	<b>25</b>
6.3	Recommended Operating Conditions .....	4	11.1	Device Support.....	25
6.4	Thermal Information .....	5	11.2	Documentation Support .....	25
6.5	Electrical Characteristics.....	5	11.3	Receiving Notification of Documentation Updates .....	25
6.6	Typical Characteristics .....	6	11.4	Community Resources.....	25
<b>7</b>	<b>Detailed Description</b> .....	<b>10</b>	11.5	Trademarks .....	25
7.1	Overview .....	10	11.6	Electrostatic Discharge Caution.....	25
7.2	Functional Block Diagram .....	11	11.7	Glossary .....	25
7.3	Feature Description.....	11	<b>12</b>	<b>Mechanical, Packaging, and Orderable Information</b> .....	<b>26</b>

## 4 Revision History

NOTE: Page numbers for previous revisions may differ from page numbers in the current version.

<b>Changes from Revision I (August 2010) to Revision J</b>	<b>Page</b>
• Changed the title of the data sheet and updated the format to the latest TI data sheet format .....	1
• Moved the ESD rating parameters for HBM and CDM from the <i>Absolute Maximum Ratings</i> table to the <i>ESD Ratings</i> table .....	4
• Added the <i>Recommended Operating Conditions</i> table, <i>Overview</i> section, <i>Feature Description</i> section, <i>Design Requirements</i> section, <i>Power Supply Recommendations</i> section, and <i>Device and Documentation Support</i> section .....	4
• Updated the symbols for the thermal resistance parameters in the <i>Thermal Information</i> table.....	5

<b>Changes from Revision H (August 2008) to Revision I</b>	<b>Page</b>
• Replaced the <i>Dissipation Ratings</i> table with the <i>Thermal Information</i> table .....	5

## 5 Pin Configuration and Functions

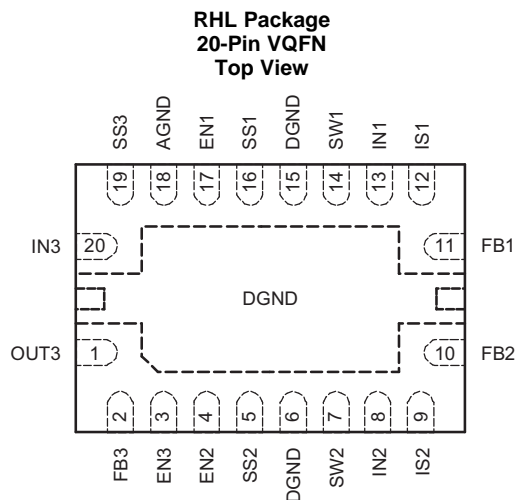

### Pin Functions

PIN		TYPE	DESCRIPTION
NAME	NO.		
AGND	18	GND	Ground connection for LDO.
DGND	6, 15, PAD	GND	Ground connection for BUCK1 and BUCK2 converters. Pins 6 and 15 should be connected to the back side exposed pad by a short metal trace as shown in the <a href="#">PCB Layout Considerations</a> section of this data sheet.
EN1	17	I	Driving the enable pin (ENx) high turns on BUCK1 regulator. Driving this pin low puts it into shutdown mode, reducing operating current. The enable pin does not trigger on fast negative going transients.
EN2	4	I	Same as EN1 but for BUCK2 controller.
EN3	3	I	Same as EN1 but for LDO.
FB1	11	I (Analog)	Feedback pin. Used to set the output voltage of BUCK1 regulator.
FB2	10	I (Analog)	Same as FB1 but for BUCK2 controller.
FB3	2	I (Analog)	Same as FB1 but for LDO.
IN1	13	I (Analog)	Input supply to BUCK1.
IN2	8	I (Analog)	Input supply to BUCK2.
IN3	20	I (Power)	Input supply to LDO.
IS1	12	I (Analog)	Current sense input for BUCK1 regulator. The voltage difference between this pin and IN1 is compared to an internal reference to set current limit. For a robust output start-up ramp, careful layout and bypassing are required. See the <a href="#">Application Information</a> section for details.
IS2	9	I (Analog)	Same as IS1 but compared to IN2 and used for BUCK2 controller.
OUT3	1	O (Power)	Regulated LDO output. A small ceramic capacitor ( $\geq 2.2\mu\text{F}$ ) is needed from this pin to ground to ensure stability.
SS1	16	I (Analog)	Connecting a capacitor between this pin and ground increases start-up time of the BUCK1 regulator by slowing the ramp-up of current limit. This high-impedance pin is noise-sensitive; careful layout is important. See the <a href="#">Typical Characteristics</a> , <a href="#">Application Information</a> , and <a href="#">PCB Layout Considerations</a> sections for details.
SS2	5	I (Analog)	Same as SS1 but for BUCK2 regulator.
SS3	19	I (Analog)	Connecting a capacitor from this pin to ground slows the start-up time of the LDO reference, thereby slowing output voltage ramp-up. See the <a href="#">Application Information</a> section for details.
SW1	14	O (Analog)	Gate drive pin for external BUCK1 P-channel MOSFET.
SW2	7	O (Analog)	Same as SW1 but for BUCK2 controller.

## 6 Specifications

### 6.1 Absolute Maximum Ratings

Over operating free-air temperature range (unless otherwise noted)<sup>(1)</sup>

		MIN	MAX	UNIT
$V_{INX}$	IN1, IN2, IN3 voltage	-0.3	7	V
$V_{ENX}$	EN1, EN2, EN3 voltage	-0.3	$V_{INX} + 0.3$	V
$V_{SWX}$	SW1, SW2, SW3 voltage	-0.3	$V_{INX} + 0.3$	V
$V_{ISX}$	IS1, IS2, IS3 voltage	-0.3	$V_{INX} + 0.3$	V
$V_{OUT3}$	OUT3 voltage	-0.3	7	V
$V_{SSX}$	SS1, SS2, SS3 voltage	-0.3	$V_{INX} + 0.3$	V
$V_{FBX}$	FB1, FB2, FB3 voltage	-0.3	3.3	V
$I_{OUT3}$	Peak LDO output current	Internally limited		
	Continuous total power dissipation	See <a href="#">Thermal Information</a> Table		
$T_J$	Junction temperature	-55	150	°C
$T_{stg}$	Storage temperature	-65	150	°C

- (1) Stresses beyond those listed under *Absolute Maximum Ratings* may cause permanent damage to the device. These are stress ratings only, which do not imply functional operation of the device at these or any other conditions beyond those indicated under *Recommended Operating Conditions*. Exposure to absolute-maximum-rated conditions for extended periods may affect device reliability.

### 6.2 ESD Ratings

			VALUE	UNIT
$V_{(ESD)}$	Electrostatic discharge	Human-body model (HBM), per ANSI/ESDA/JEDEC JS-001 <sup>(1)</sup>	1000	V
		Charged-device model (CDM), per JEDEC specification JESD22-C101 <sup>(2)</sup>	500	

- (1) JEDEC document JEP155 states that 500-V HBM allows safe manufacturing with a standard ESD control process.  
 (2) JEDEC document JEP157 states that 250-V CDM allows safe manufacturing with a standard ESD control process.

### 6.3 Recommended Operating Conditions

over operating free-air temperature range (unless otherwise noted)

		MIN	NOM	MAX	UNIT
$V_{IN1}$	Input voltage at IN1 pin	2.2		6.5	V
$V_{OUT1}$	Output voltage of BUCK1	1.2		$V_{IN1}$	V
$I_{OUT1}$	Maximum output current of BUCK1			3	A
$V_{IN2}$	Input voltage at IN2 pin	2.2		6.5	V
$V_{OUT2}$	Output voltage of BUCK1	1.2		$V_{IN2}$	V
$I_{OUT2}$	Maximum output current of BUCK2			3	A
$V_{IN3}$	Input voltage at IN3 pin	2.2		6.5	V
$V_{OUT3}$	Output voltage of LDO	1		$V_{IN3} - V_{DO}$	V
$I_{OUT3}$	Maximum output current of LDO			300	mA

## 6.4 Thermal Information

THERMAL METRIC <sup>(1)</sup>		TPS75003	
		RHL (VQFN)	
		20 PINS	
Symbol	Description	Value	Unit
$R_{\theta JA}$	Junction-to-ambient thermal resistance	42.6	°C/W
$R_{\theta JC(top)}$	Junction-to-case (top) thermal resistance	51.8	°C/W
$R_{\theta JB}$	Junction-to-board thermal resistance	39.5	°C/W
$\psi_{JT}$	Junction-to-top characterization parameter	0.6	°C/W
$\psi_{JB}$	Junction-to-board characterization parameter	14.2	°C/W
$R_{\theta JC(bot)}$	Junction-to-case (bottom) thermal resistance	2.8	°C/W

(1) For more information about traditional and new thermal metrics, see the [Semiconductor and IC Package Thermal Metrics application report](#).

## 6.5 Electrical Characteristics

$V_{EN1} = V_{IN1}$ ,  $V_{EN2} = V_{IN2}$ ,  $V_{EN3} = V_{IN3}$ ,  $V_{IN1} = V_{IN2} = 2.2V$ ,  $V_{IN3} = 3.0V$ ,  $V_{OUT3} = 2.5V$ ,  $C_{OUT1} = C_{OUT2} = 47\mu F$ ,  $C_{OUT3} = 2.2\mu F$ ,  $T_A = -40^\circ C$  to  $+85^\circ C$ , unless otherwise noted. Typical values are at  $T_A = +25^\circ C$ .

PARAMETER	TEST CONDITIONS	MIN	TYP	MAX	UNIT	
<b>Supply and Logic</b>						
$V_{INX}$	Input Voltage Range (IN1, IN2, IN3) <sup>(1)</sup>	2.2		6.5	V	
$I_Q$	Quiescent Current, $I_Q = I_{DGND} + I_{AGND}$	$I_{OUT1} = I_{OUT2} = 0mA$ , $I_{OUT3} = 1mA$		75	150	$\mu A$
$I_{SHDN}$	Shutdown Supply Current	$V_{EN1} = V_{EN2} = V_{EN3} = 0V$		0.05	3	$\mu A$
$V_{IH1, 2}$	Enable High, enabled (EN1, EN2)	1.4		$V_{INX}$	V	
$V_{IH3}$	Enable High, enabled (EN3)	1.14		$V_{IN3}$	V	
$V_{ILX}$	Enable Low, shutdown (EN1, EN2, EN3)	0		0.3	V	
$I_{ENX}$	Enable pin current (EN1, EN2, EN3)		0.01	0.5	$\mu A$	
<b>Buck Controllers 1 and 2</b>						
$V_{OUT1,2}$	Adjustable Output Voltage Range <sup>(2)</sup>	$V_{FBX}$		$V_{INX}$	V	
$V_{FB1,2}$	Feedback Voltage (FB1, FB2)	1.220			V	
	Feedback Voltage Accuracy <sup>(1)</sup> (FB1, FB2)	-2%		2%		
$I_{FB1,2}$	Current into FB1, FB2 pins	0.01		0.5	$\mu A$	
$V_{IS1,2}$	Reference Voltage for Current Sense	80	100	120	mV	
$I_{IS1,2}$	Current into IS1, IS2 Pins	0.01		0.5	$\mu A$	
$\Delta V_{OUT\%}/\Delta V_{IN}$	Line Regulation <sup>(1)</sup>	Measured with the circuit in <a href="#">Figure 18</a> , $V_{OUT} + 0.5V \leq V_{IN} \leq 6.5V$		0.1	%/V	
$\Delta V_{OUT\%}/\Delta I_{OUT}$	Load Regulation	Measured with the circuit in <a href="#">Figure 18</a> , $30mA \leq I_{OUT} \leq 2A$		0.6	%/A	
$\eta_{1,2}$	Efficiency <sup>(3)</sup>	Measured with the circuit in <a href="#">Figure 18</a> , $I_{OUT} = 1A$		94%		
$t_{STR1,2}$	Startup Time <sup>(3)</sup>	Measured with the circuit in <a href="#">Figure 18</a> , $R_L = 6\Omega$ , $C_{OUT} = 100\mu F$ , $C_{SS} = 2.2nF$		5	ms	

(1) To be in regulation, minimum  $V_{IN1}$  (or  $V_{IN2}$ ) must be greater than  $V_{OUT1,NOM}$  (or  $V_{OUT2,NOM}$ ) by an amount determined by external components. Minimum  $V_{IN3} = V_{OUT3} + V_{DO}$  or 2.2V, whichever is greater.

(2) Maximum  $V_{OUT}$  depends on external components and will be less than  $V_{IN}$ .

(3) Depends on external components.

### Electrical Characteristics (continued)

$V_{EN1} = V_{IN1}$ ,  $V_{EN2} = V_{IN2}$ ,  $V_{EN3} = V_{IN3}$ ,  $V_{IN1} = V_{IN2} = 2.2V$ ,  $V_{IN3} = 3.0V$ ,  $V_{OUT3} = 2.5V$ ,  $C_{OUT1} = C_{OUT2} = 47\mu F$ ,  $C_{OUT3} = 2.2\mu F$ ,  $T_A = -40^\circ C$  to  $+85^\circ C$ , unless otherwise noted. Typical values are at  $T_A = +25^\circ C$ .

PARAMETER	TEST CONDITIONS	MIN	TYP	MAX	UNIT	
$R_{DS,ON1,2}$	Gate Driver P-Channel and N-Channel MOSFET On-Resistance	$V_{IN1,2} > 2.5V$	4		$\Omega$	
		$V_{IN1,2} = 2.2V$	6			
$I_{SW1,2}$	Gate Driver P-Channel and N-Channel MOSFET Drive Current		100		mA	
$t_{ON}$	Minimum On Time	1.36	1.55	1.84	$\mu s$	
$t_{OFF}$	Minimum Off Time	0.44	0.65	0.86	$\mu s$	
<b>LDO</b>						
$V_{OUT3}$	Output Voltage Range	1		$6.5 - V_{DO}$	V	
$V_{FB3}$	Feedback Pin Voltage		0.507		V	
	Feedback Pin Voltage Accuracy <sup>(1)</sup>	$2.95V \leq V_{IN3} \leq 6.5V$ $1mA \leq I_{OUT3} \leq 300mA$	-4%	4%		
$\Delta V_{OUT\%}/\Delta V_{IN}$	Line Regulation <sup>(1)</sup>	$V_{OUT3} + 0.5V \leq V_{IN3} \leq 6.5V$	0.075		%/V	
$\Delta V_{OUT\%}/\Delta I_{OUT}$	Load Regulation	$10mA \leq I_{OUT3} \leq 300mA$	0.01		%/mA	
$V_{DO}$	Dropout Voltage ( $V_{IN} = V_{OUT(NOM)} - 0.1$ ) <sup>(4)</sup>	$I_{OUT3} = 300mA$	250	350	mV	
$I_{CL3}$	Current Limit	$V_{OUT} = 0.9 \times V_{OUT(NOM)}$	375	600	1000	mA
$I_{FB3}$	Current into FB3 pin		0.03	0.1	$\mu A$	
$V_n$	Output Noise	BW = 100Hz – 100kHz, $I_{OUT3} = 300mA$	400		$\mu V_{RMS}$	
$t_{SD}$	Thermal Shutdown Temperature for LDO	Shutdown, Temp Increasing	175		$^\circ C$	
		Reset, Temp Decreasing	160			
UVLO	Under-Voltage Lockout Threshold	$V_{IN}$ Rising	1.80		V	
	Under-Voltage Lockout Hysteresis	$V_{IN}$ Falling	100		mV	

(4)  $V_{DO}$  does not apply when  $V_{OUT} + V_{DO} < 2.2V$ .

## 6.6 Typical Characteristics

Measured using circuit in [Figure 18](#).

### 6.6.1 Buck Converter

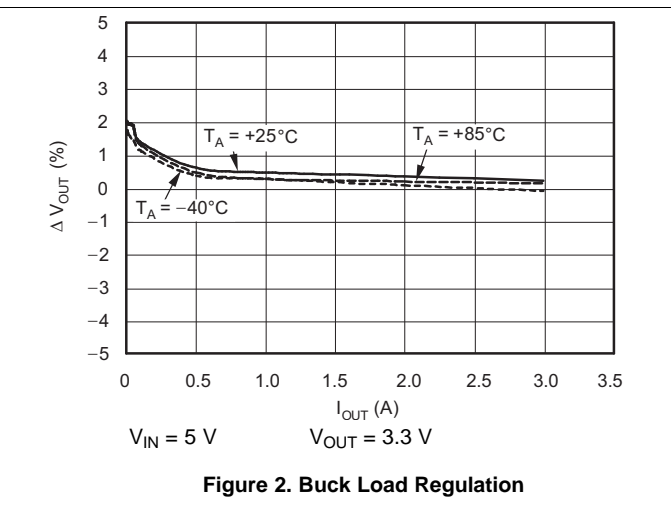
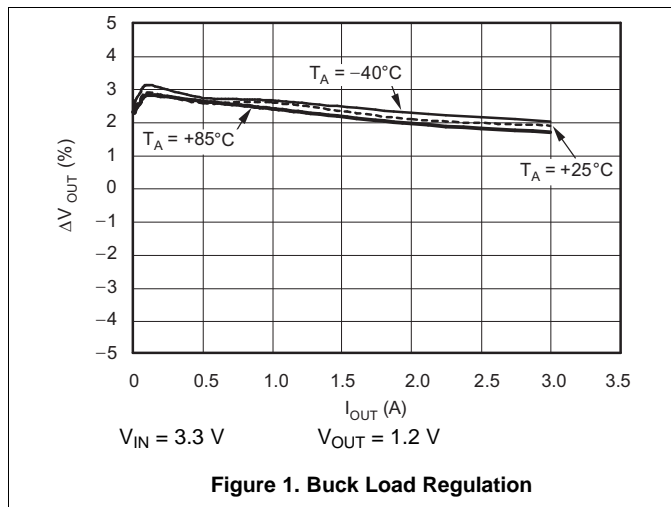

Buck Converter (continued)

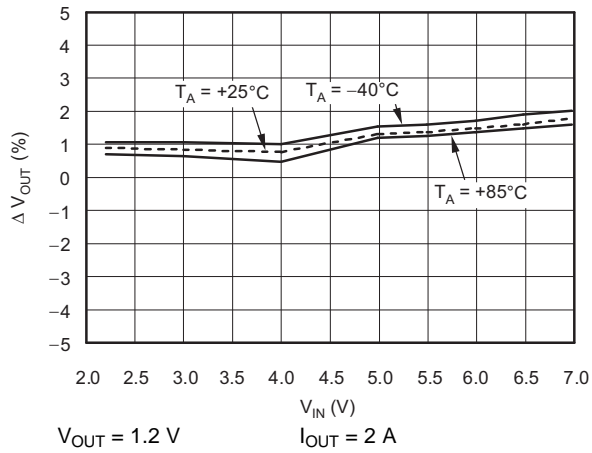

Figure 3. Buck Line Regulation

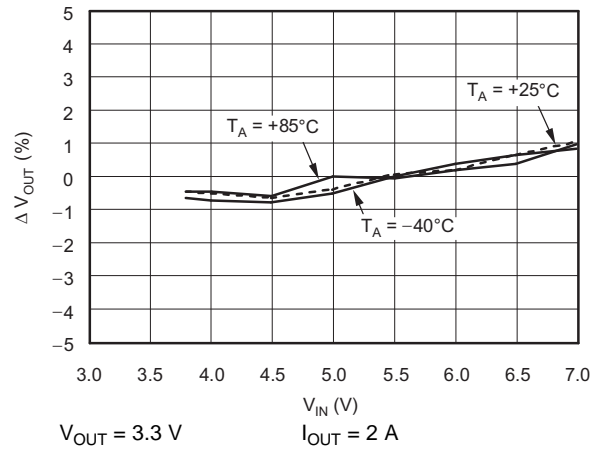

Figure 4. Buck Line Regulation

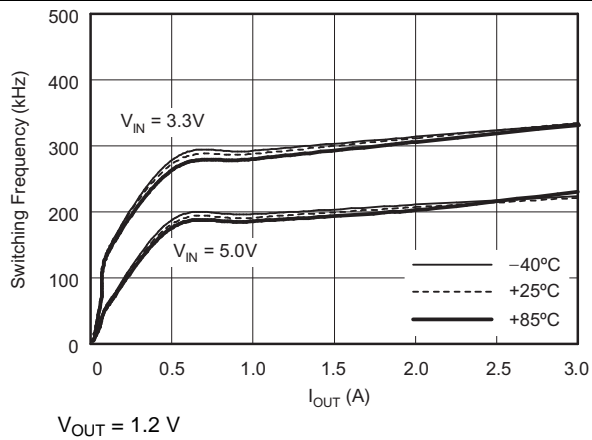

Figure 5. Buck Switching Frequency vs  $I_{OUT}$ ,  $T_A$

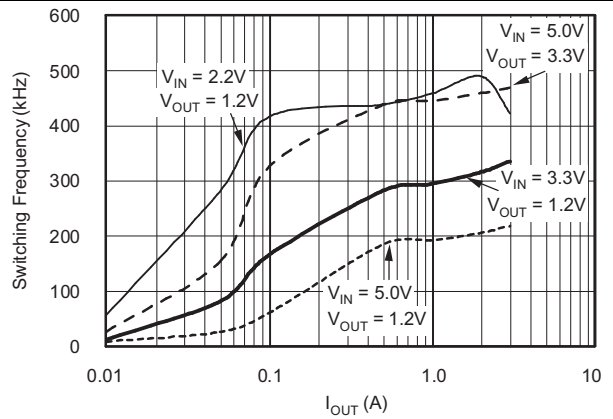

Figure 6. Buck Switching Frequency vs  $I_{OUT}$

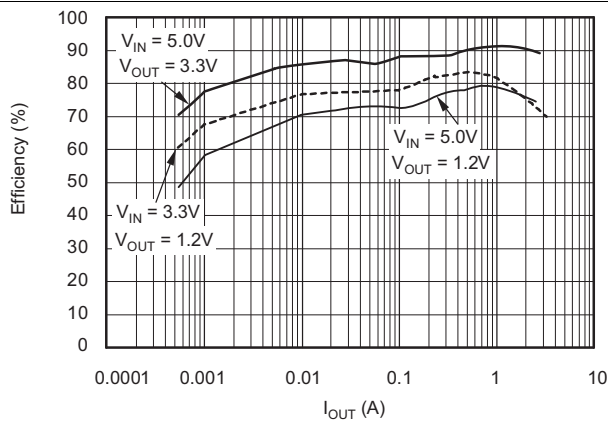

Figure 7. Efficiency vs  $I_{OUT}$

6.6.2 LDO Converter

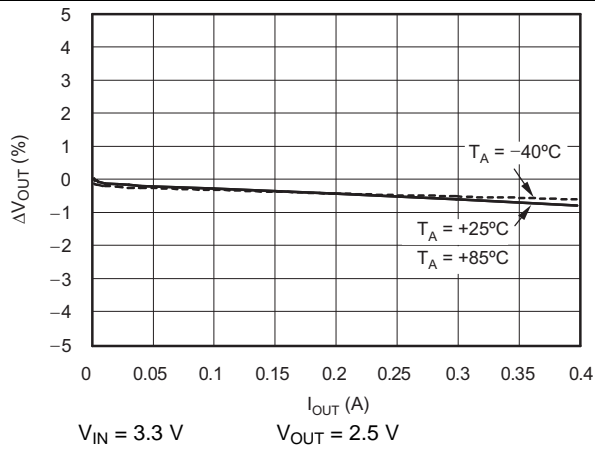

Figure 8. LDO Load Regulation

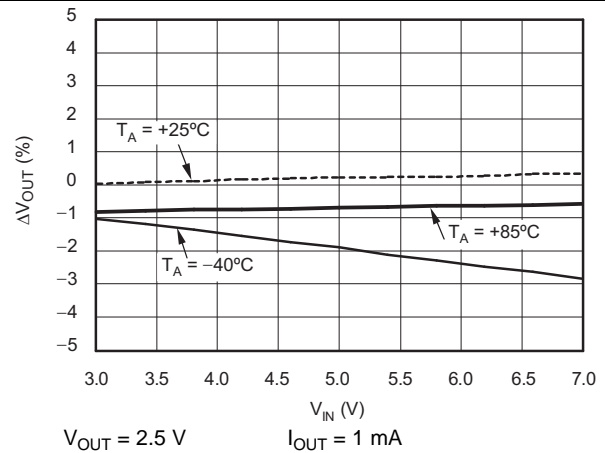

Figure 9. LDO Line Regulation

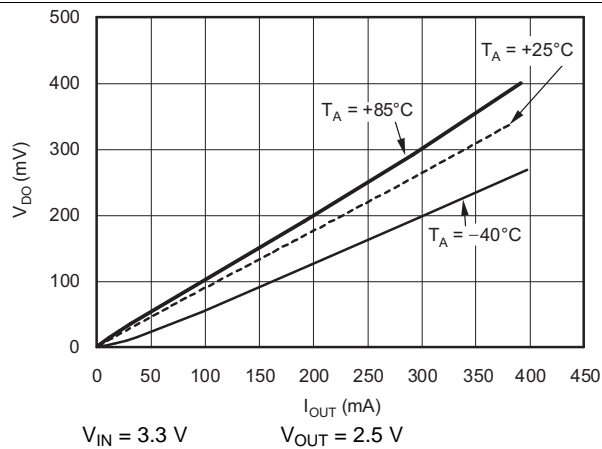

Figure 10. LDO Dropout vs  $I_{OUT}$

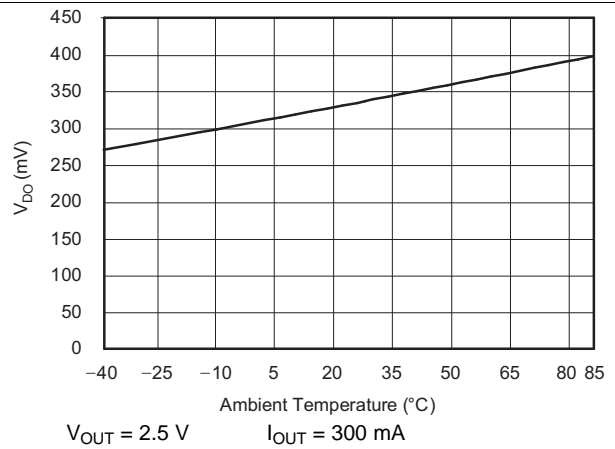

Figure 11. LDO Dropout vs  $T_A$

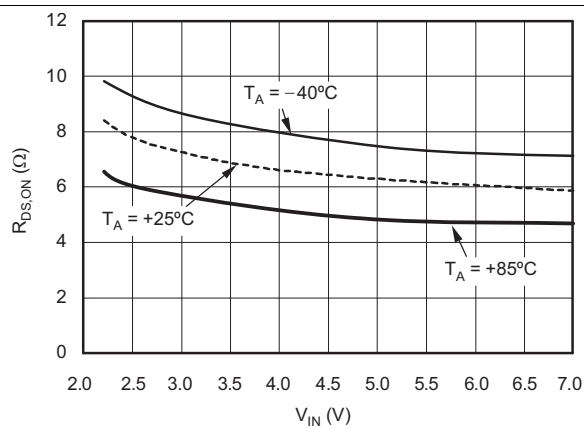

Figure 12.  $R_{DS,ON}$  PMOS vs  $V_{IN}$

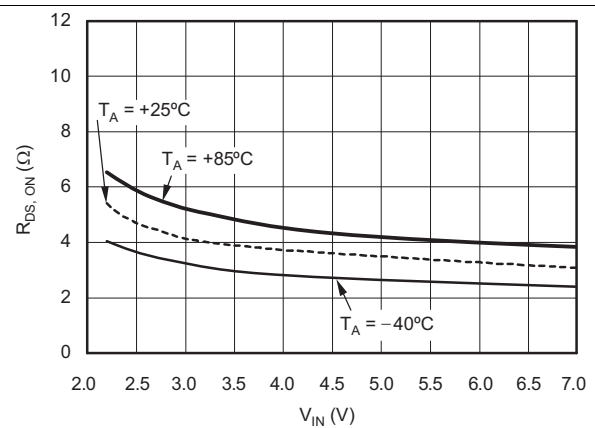
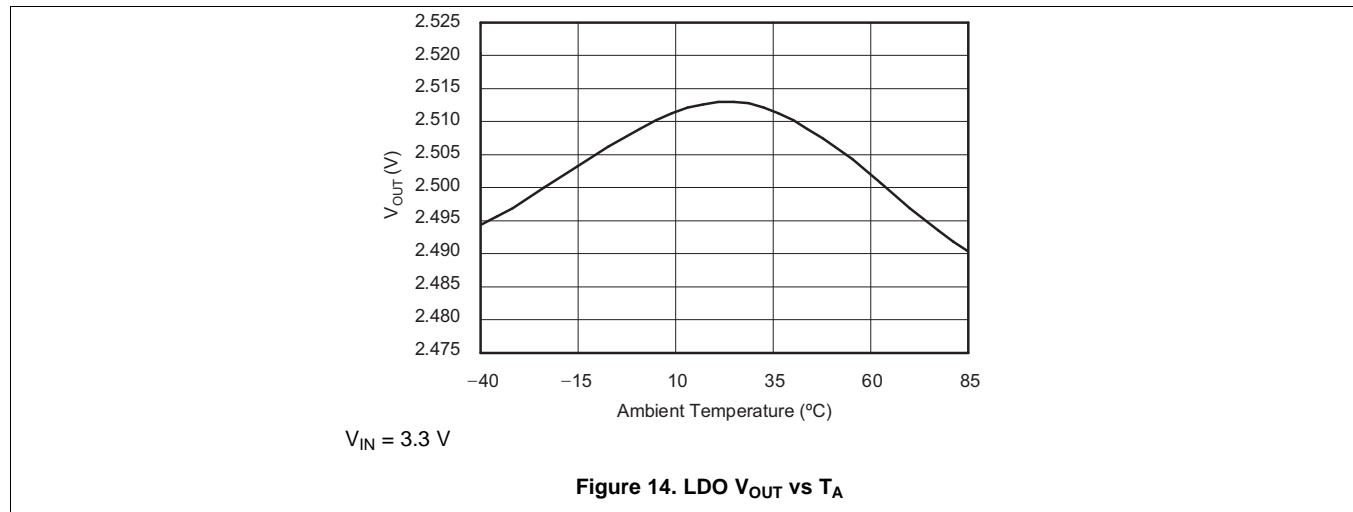

Figure 13.  $R_{DS,ON}$  NMOS vs  $V_{IN}$

**LDO Converter (continued)**



## 7 Detailed Description

### 7.1 Overview

The TPS75003 device is a power management IC (PMIC) with two buck controllers and one integrated LDO regulator. The three voltage regulators have independent enable pins for flexible power sequence timing, and all of the output voltages are set by external feedback resistor dividers. The independent power regulators can be wired in parallel, in series, or connected to separate input voltages as needed to meet the requirements of the application.

The two buck controllers are identical and operate over a input voltage range of 2.2 V to 6.5 V to supply a load with an externally configurable output voltage with up to 3-A of current. The buck controllers drive the gate of a single PMOS FET in an asynchronous buck regulator architecture. The use of a PMOS FET lets the buck regulator operate with 100% duty cycle when the input voltage is approximately equal to or less than the desired output voltage. The buck controllers have an externally configurable current sense feature to limit the output current and protect the PMOS FET. The buck controllers have an externally configurable soft-start feature that ramps the voltage and meet the timing requirements of the load.

The LDO regulator integrates the FET and operates over the same input voltage range of 2.2 V to 6.5 V to supply a load with an externally configurable output voltage with up to 300-mA of current. The LDO regulator includes integrated current limiting and thermal protection features. The LDO regulator also has an externally configurable soft-start feature to ramp the voltage to meet desired timing requirements.

## 7.2 Functional Block Diagram

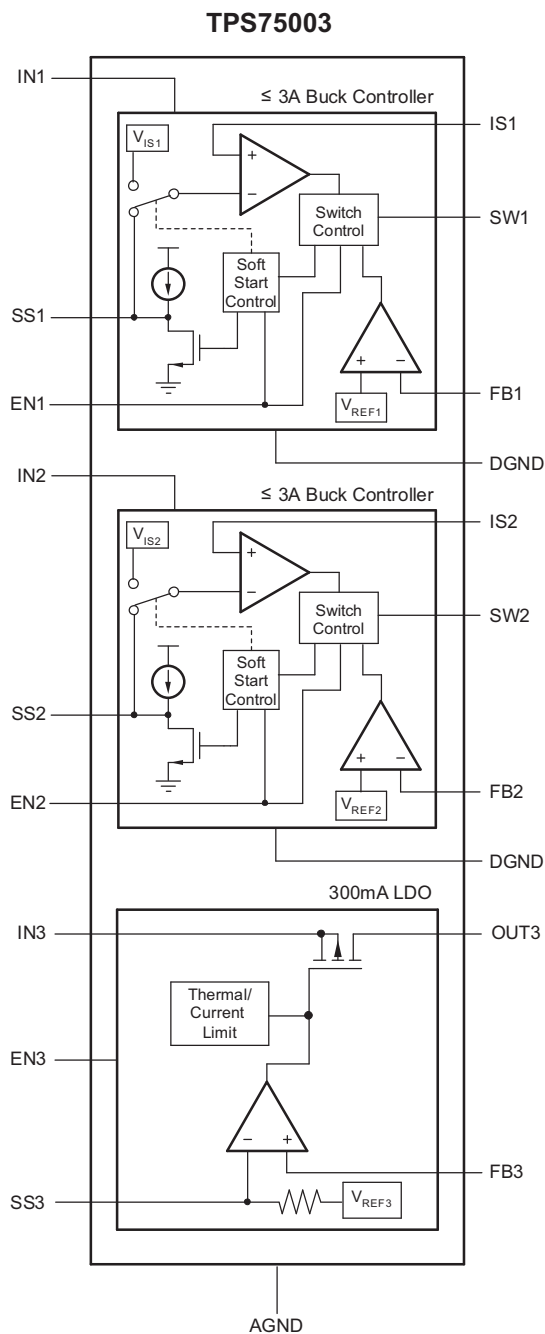

## 7.3 Feature Description

### 7.3.1 Operation (Buck Controllers)

Channels 1 and 2 have two identical non-synchronous buck controllers that use minimum on-time and minimum off-time hysteretic control (see Figure 18. For clarity, BUCK1 is used throughout the discussion of device operation. When  $V_{OUT1}$  is less than its target, an external PMOS (Q1) is turned on for at least the minimum on-time, increasing current through the inductor (L1) until  $V_{OUT1}$  reaches its target value or the current limit (set by R1) is reached. When either of these conditions is met, the PMOS is switched off for at least the minimum off-time of the device. After the minimum off-time has passed, the output voltage is monitored and the switch is turned on again when necessary.

## Feature Description (continued)

When output current is low, the buck controllers operate in discontinuous mode. In this mode, each switching cycle begins at zero inductor current, rises to a maximum value, then falls back to zero current. When current reaches zero on the falling edge, ringing occurs at the resonant frequency of the inductor and stray switch node capacitance. This operation is normal; it does not affect circuit performance, and can be minimized if desired by using an RC snubber, a resistor in series with the gate of the PMOS, or both as shown in [Figure 15](#).

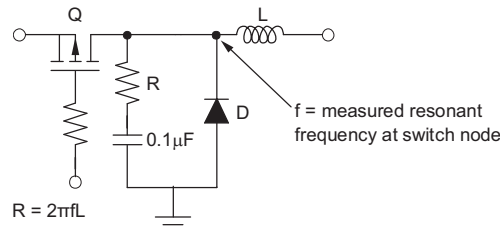

**Figure 15. RC Snubber and Series Gate Resistor Used to Minimize Ringing**

At higher output currents, the TPS75003 device operates in continuous mode. In continuous mode, there is no ringing at the switch node and  $V_{OUT}$  is equal to  $V_{IN}$  times the duty cycle of the switching waveform.

When  $V_{IN}$  approaches or falls to less than  $V_{OUT}$ , the buck controllers operate in 100% duty cycle mode, fully turning on the external PMOS to let regulation occur at a lower dropout than would otherwise be possible.

### 7.3.2 Enable (Buck Controllers)

The enable pins (EN1 and EN2) for the buck controllers are active high. When the enable pin is driven low and input voltage is present at IN1 or IN2, an on-chip FET is turned on to discharge the soft-start pin SS1 or SS2, respectively. If the soft-start feature is being used, enable should be driven high at least 10µs after  $V_{IN}$  is applied to make sure that this discharge cycle occurs.

### 7.3.3 UVLO (Buck Controllers)

The device has an undervoltage lockout circuit to prevent the turnon of the external PMOS (Q1 or Q2) until a reliable operating voltage is reached on the appropriate regulator (IN1 or IN2). This prevents the buck controllers from misoperation at low input voltages.

### 7.3.4 Current Limit (Buck Controllers)

An external resistor (R1 or R2) is used to set the current limit for the external PMOS transistor (Q1 or Q2). These resistors are connected between IN1 and IS1 (or IN2 and IS2) to provide a reference voltage across these pins that is proportional to the current flowing through the PMOS transistor. This reference voltage is compared to an internal reference to determine if an overcurrent condition exists. When current limit is exceeded, the external PMOS is turned off for the minimum off-time. Current limit detection is disabled for 10ns any time the PMOS is turned on to avoid triggering on switching noise. In 100% duty cycle mode, current limit is always enabled. Current limit is calculated using the  $V_{IS1}$  or  $V_{IS2}$  specification in the [Electrical Characteristics](#) section as shown in [Equation 1](#).

$$I_{LIMIT} = \frac{V_{IS1,2}}{R_{1,2}} \quad (1)$$

The current limit resistor must be appropriately rated for the dissipated power determined by its RMS current calculated by [Equation 2](#).

$$I_{RMS} \approx I_{OUT} \sqrt{D} = I_{OUT} \sqrt{\frac{V_{OUT}}{V_{IN}}}$$

$$P_{DISS} = (I_{RMS})^2 \times R \quad (2)$$

## Feature Description (continued)

For low-cost applications the  $I_{S1,2}$  pin can be connected to the drain of the PMOS, using  $R_{DS,ON}$  instead of R1 or R2 to set current limit. Variations in the PMOS  $R_{DS,ON}$  must be considered to make sure that current limit will protect external components such as the inductor, the diode, and the switch itself from damage as a result of overcurrent.

### 7.3.5 Short-Circuit Protection (Buck Controllers)

In an overload condition, the current rating of the external components (PMOS, diode, and inductor) can be exceeded. To help guard against this, the TPS75003 device increases its minimum off-time when the voltage at the feedback pin is less than the reference voltage. When the output is shorted ( $V_{FB}$  is zero), the minimum off-time is increased to approximately  $4\mu s$ . The increase in off-time is proportional to the difference between the voltage at the feedback pin and the internal reference.

### 7.3.6 Soft-Start (Buck Controllers)

The buck controllers each have independent soft-start capability to limit inrush during start-up and to meet timing requirements of the Xilinx Spartan-3 FPGA. Limiting inrush current by using soft-start, or by staggering the turnon of power rails, also guards against voltage drops at the input source due to its output impedance. Refer to the soft-start circuitry shown in Figure 16 and the soft-start timing diagram shown in Figure 17. The BUCK1 controller is discussed in this section; it is identical to BUCK2. Note that pins SS1 and SS2 are very high-impedance and cannot be probed using a typical oscilloscope setup. When input voltage is applied at IN1 and EN1 is driven low, any charge on the SS pin is discharged by an on-chip pulldown transistor. When EN1 is driven high, an on-chip current source starts charging the external soft-start capacitor  $C_{SS1}$ . The voltage on the capacitor is compared to the voltage across the current sense resistor R1 to determine if an overcurrent condition exists. If the voltage drop across the sense resistor becomes greater than the reference voltage, then the external PMOS is shut off for the minimum off-time. This implementation provides a cycle-by-cycle current limit and lets the user configure the soft-start time over a wide range for most applications. For detailed information on selecting  $C_{SS1}$  and  $C_{SS2}$ , see the [Soft-Start Capacitor Selection \(Buck Controllers\)](#) section.

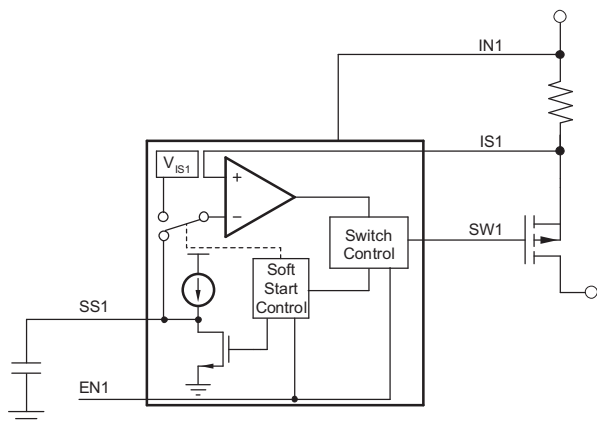

Figure 16. Soft-Start Circuitry

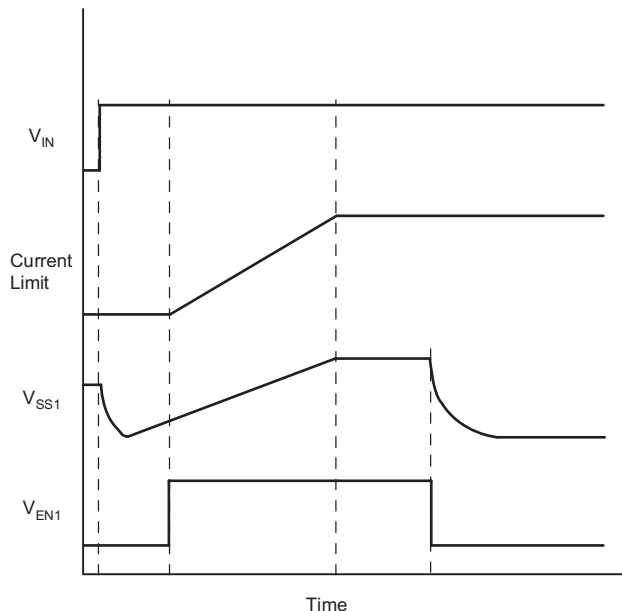

Figure 17. Soft-Start Timing Diagram

### 7.3.7 LDO Operation

The TPS75003 LDO regulator uses a PMOS pass transistor and is offered in an adjustable version to easily configure any output voltage. When used to power  $V_{CC,AUX}$  the LDO regulator output voltage is set to 2.5V; the LDO regulator can optionally be set to other output voltages to power other circuitry. The LDO regulator has integrated soft-start, independent enable, and short-circuit and thermal protection. The LDO regulator can be used to power  $V_{CC,AUX}$  on the Xilinx Spartan-3 FPGA when 3.3V JTAG signals are used as described in the [Using 3.3-V Signals for Spartan-3 Configuration and JTAG Ports application note](#).

### 7.3.8 Internal Current Limit (LDO)

The internal current limit of the LDO regulator helps protect the regulator during fault conditions. When an overcurrent condition is detected, the output voltage is decreased until the current falls to a level that will not damage the device. For good device reliability, the LDO regulator should not operate at the current limit.

### 7.3.9 Enable Pin (LDO)

The active high enable pin (EN3) can be used to put the device into shutdown mode. If shutdown and soft-start capability are not required, EN3 can be tied to IN3.

### 7.3.10 Dropout Voltage (LDO)

The LDO regulator uses a PMOS transistor to achieve low dropout. When  $(V_{IN} - V_{OUT})$  is less than the dropout voltage ( $V_{DO}$ ), the pass transistor is in its linear region of operation, and the input-output resistance is the  $R_{DS,ON}$  of the pass transistor. In this region, the LDO regulator is said to be out of regulation; ripple rejection, line regulation, and load regulation degrade as  $(V_{IN} - V_{OUT})$  decreases to much lower than 0.5V.

### 7.3.11 Transient Response (LDO)

The LDO regulator does not have an on-chip pulldown circuit for output is overvoltage conditions. This feature lets the device be used in applications that connect higher voltage sources such as an alternate power supply to the output. This design also results in an output overshoot of several percent if the load current quickly drops to zero. The amplitude of overshoot can be reduced by increasing  $C_{OUT}$ ; the duration of overshoot can be decreased by adding a load resistor.

### 7.3.12 Thermal Protection (LDO)

Thermal protection disables the output when the junction temperature,  $T_J$ , reaches unsafe levels. When the junction temperature cools, the output is enabled again. The thermal protection circuit may cycle on and off depending on the power dissipation, thermal resistance, and ambient temperature. This cycling limits the dissipation of the regulator, protecting it from damage. For good long term reliability, the device should not be continuously operated at or near thermal shutdown.

### 7.3.13 Power Dissipation (LDO)

The TPS75003 device is available in a QFN-style package with an exposed lead frame on the package underside. The exposed lead frame is the primary path for removing heat and should be soldered to a PC board that is configured to remove the amount of power dissipated by the LDO regulator, as calculated by [Equation 3](#).

$$P_D = (V_{IN3} - V_{OUT3}) \times I_{OUT3} \quad (3)$$

Power dissipation can be minimized by using the lowest possible input voltage necessary to ensure the required output voltage. The two buck converters do not contribute a significant amount of dissipated power. Using heavier copper will increase the overall effectiveness of removing heat from the device. The addition of plated through-holes to heat-dissipating layers will also improve the heatsink effectiveness.

## 8 Application and Implementation

### NOTE

Information in the following applications sections is not part of the TI component specification, and TI does not warrant its accuracy or completeness. TI's customers are responsible for determining suitability of components for their purposes. Customers should validate and test their design implementation to confirm system functionality.

### 8.1 Application Information

The TPS75003 is an integrated power management IC designed specifically to power DSPs and FPGAs such as the Xilinx Spartan-3, Spartan-3E and Spartan-3L. Two non-synchronous buck controllers can be configured to supply up to 3A for both CORE and I/O rails. A low dropout linear regulator powers auxiliary rails up to 300mA. All channels have independent enable and soft-start, allowing control of inrush current and output voltage ramp time as required by the application.

Table 1 through Table 4 show component values that have been tested for use with up to 3A load currents. Inductors in Table 1 are tested up to the respective saturation currents. Other similar external components can be substituted as desired; however, in all cases the circuits that are used should be tested for compliance to application requirements.

**Table 1. Inductors Tested with the TPS75003**

PART NUMBER	MANUFACTURER	INDUCTANCE	DC RESISTANCE	SATURATION CURRENT
SLF7032T-100M1R4	TDK	10 $\mu$ H $\pm$ 20%	53m $\Omega$ $\pm$ 20%	1.4A
SLF6025-150MR88	TDK	15 $\mu$ H $\pm$ 20%	85m $\Omega$ $\pm$ 20%	0.88A
CDRH6D28-5R0	Sumida	5 $\mu$ H	23m $\Omega$	2.4A
CDRH6D38-5R0	Sumida	5 $\mu$ H	18m $\Omega$	2.9A
CDRH103R-100	Sumida	10 $\mu$ H	45m $\Omega$	2.4A
CDRH4D28-100	Sumida	10 $\mu$ H	96m $\Omega$	1.0A
CDRH8D43-150	Sumida	15 $\mu$ H	42m $\Omega$	2.9A
CDRH5D18-6R2	Sumida	6.2 $\mu$ H	71m $\Omega$	1.4A
DO3316P-472	Coilcraft	4.7 $\mu$ H	18m $\Omega$	5.4A
MSS7341-153	Coilcraft	15 $\mu$ H	55m $\Omega$	1.6A
MSS7341-223	Coilcraft	22 $\mu$ H	82m $\Omega$	1.26A
744052006	Würth	6.2 $\mu$ H	80m $\Omega$	1.45A
74451115	Würth	15 $\mu$ H	90m $\Omega$	0.8A

**Table 2. PMOS Transistors Tested with the TPS75003**

PART NUMBER	MANUFACTURER	R <sub>DS,ON</sub> (TYP)	V <sub>DS</sub>	I <sub>D</sub>	PACKAGE
SI5457DC-T1-GE3	Vishay	0.056 $\Omega$ at VGS = -2.5V	-20V	-6A at +25°C	1206-8
SI2301BDS-T1-E3	Vishay	0.15 $\Omega$ at VGS = -2.5V	-20V	-2.0A at +25°C	SOT-23
SI2323DS-T1-E3	Vishay	0.052 $\Omega$ at VGS = -2.5V	-20V	-4.1A at +25°C	SOT-23
FDG328P	Fairchild	0.12 $\Omega$ at VGS = -2.5V	-20V	-1.5A	SC70-6

**Table 3. Diodes Tested with the TPS75003**

PART NUMBER	MANUFACTURER	V <sub>R</sub>	I <sub>F</sub>	PACKAGE
FSV240AF	ON Semiconductor / Fairchild	40V	2.0A	DO-214-2
FSV340FP	ON Semiconductor / Fairchild	40V	3.0A	SOD-123-2
SS32	ON Semiconductor / Fairchild	20V	3.0A	DO-214AB
ZHCS2000TA	Zetex	40V	2.0A	SOT-23-6
B320AE-13	Diodes Inc.	20V	3.0A	SMA

**Table 4. Capacitors Tested with the TPS75003**

PART NUMBER	MANUFACTURER	CAPACITANCE	ESR	VOLTAGE RATING
10TPB47M (PosCap)	Panasonic	47 $\mu$ F	0.07 $\Omega$	10V
T491D476M010AT	Kemet	47 $\mu$ F	0.8 $\Omega$	10V
T495D476K016ATE180	Kemet	47 $\mu$ F	0.18 $\Omega$	16V
TR3C476K016C0300	Vishay	47 $\mu$ F	0.3 $\Omega$	16V
T495D107M006ATE050	Kemet	100 $\mu$ F	0.05 $\Omega$	6.3V
TPSC107M006R0075	AVX	100 $\mu$ F	0.075 $\Omega$	6.3V
6TPE100MPB (PosCap)	Panasonic	100 $\mu$ F	0.025 $\Omega$	6.3V
TR3C107K6R3C0125	Vishay	100 $\mu$ F	0.25 $\Omega$	6.3V

## 8.2 Typical Application

Figure 18 shows a typical application circuit for powering the Xilinx Spartan-3 FPGA.

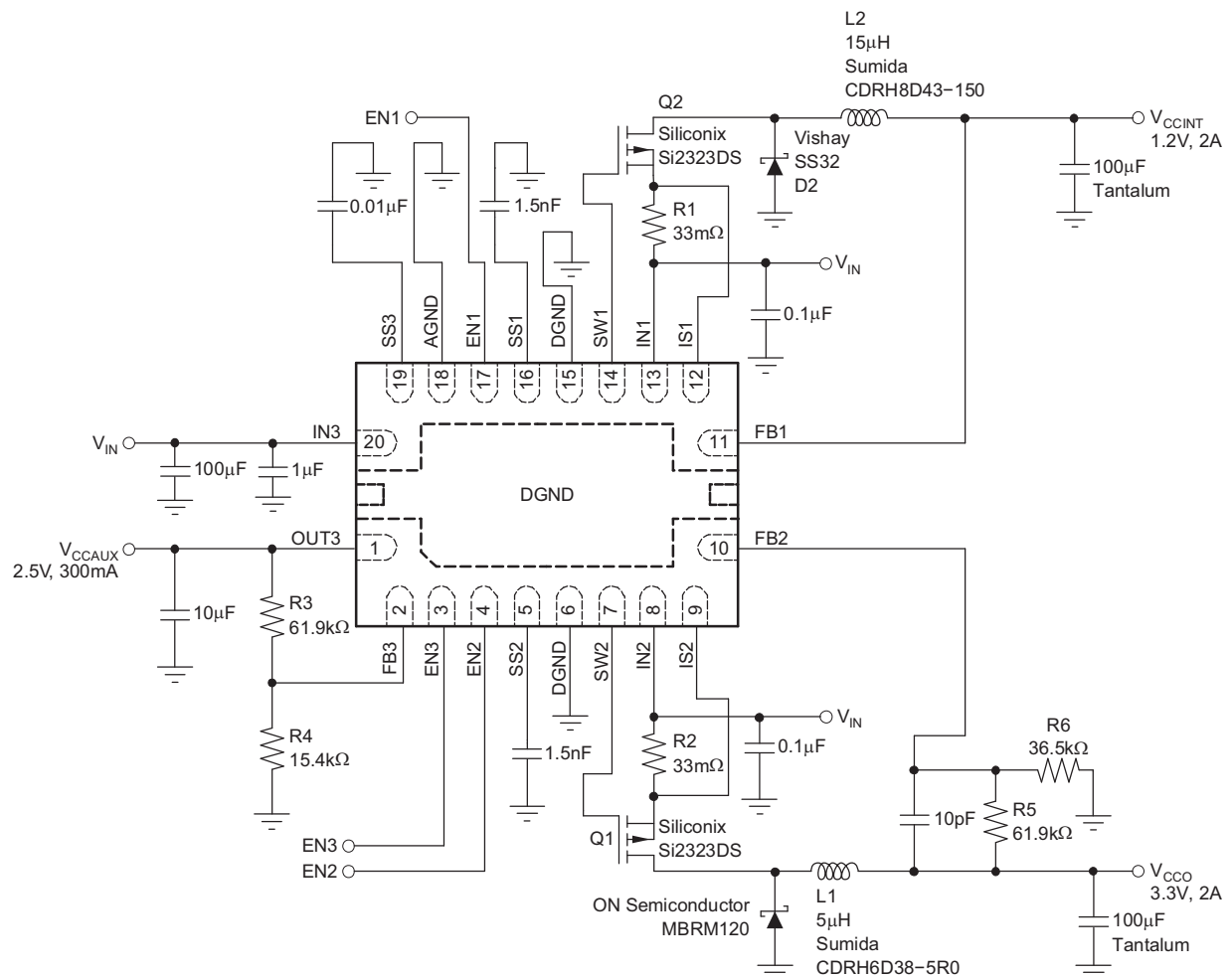

**Figure 18. Typical Application Circuit for Powering the Xilinx Spartan-3 FPGA**

## Typical Application (continued)

### 8.2.1 Design Requirements

Table 5 lists the design requirements that are met by the application shown in Figure 18

**Table 5. Design Parameters for Xilinx Spartan-3 FPGA Design**

PARAMETER	DESCRIPTION	VALUE	UNIT
V <sub>IN</sub>	Input power supply to all regulators: BUCK1 (IN1), BUCK2 (IN2), and LDO (IN3)	3.3 to 6.5	V
V <sub>OUT1</sub>	Output of BUCK1 regulator V <sub>CCINT</sub> , core rail power for the FPGA	1.2	V
I <sub>OUT1</sub>	Load current of FPGA for V <sub>CCINT</sub> rail	2	A
V <sub>OUT2</sub>	Output of BUCK2 regulator V <sub>CCO</sub> , I/O rail power for the FPGA	3.3	V
I <sub>OUT2</sub>	Load current of FPGA for V <sub>CCO</sub> rail	2	A
V <sub>OUT3</sub>	Output of LDO regulator V <sub>CCAUX</sub> , auxiliary rail power for the FPGA	2.5	V
I <sub>OUT3</sub>	Load current of FPGA for V <sub>CCAUX</sub> rail	300	mA

### 8.2.2 Detailed Design Procedure

#### 8.2.2.1 Input Capacitor C<sub>IN1</sub>, C<sub>IN2</sub> Selection (Buck Controllers)

It is good analog design practice to place input capacitors near the inputs of the device in order to ensure a low impedance input supply. 10μF to 22μF of capacitance for each buck converter is adequate for most applications, and should be placed within 100mils (0.01in, or 2.54mm) of the IN1 and IN2 pins to minimize the effects of pulsed current switching noise on the soft-start circuitry during the first ~1V of output voltage ramp. Low ESR capacitors also help to minimize noise on the supply line. The minimum value of capacitance can be estimated using Equation 4:

$$C_{IN, MIN} + \frac{(1/2)L \times (\Delta I_L)^2}{V_{(RIPPLE)} \times V_{IN}} \approx \frac{(1/2)L \times (0.3 \times I_{OUT})^2}{V_{(RIPPLE)} \times V_{IN}} \quad (4)$$

Note that the capacitors must be able to handle the RMS current in continuous conduction mode, which can be calculated using Equation 5:

$$I_{C,IN(RMS)} \approx I_{OUT} \sqrt{\left( \frac{V_{OUT}}{V_{IN,MIN}} \right)} \quad (5)$$

#### 8.2.2.2 Inductor Value Selection (Buck Controllers)

The inductor is chosen based on inductance value and maximum current rating. Larger inductors reduce current ripple (and therefore, output voltage ripple) but are physically larger and more expensive. Inductors with lower DC resistance typically improve efficiency, but also have higher cost and larger physical size. The buck converters work well with inductor values between 4.7μH and 47μH in most applications. When selecting an inductor, the current rating should exceed the current limit set by R<sub>IS</sub> or R<sub>DS,ON</sub> (see the [Current Limit \(Buck Controllers\)](#) section). To determine the minimum inductor size, first determine if the device will operate in minimum on-time or minimum off-time mode. The device will operate in minimum on-time mode if Equation 6 is satisfied:

$$V_{IN} - V_{OUT} - I_{OUT} \times R_{DS,ON} - R_L \times I_{OUT} \geq \frac{t_{OFF,MIN} \times (V_{OUT} + V_{SCHOTTKY} + R_L \times I_{OUT})}{t_{ON,MIN}}$$

where

- R<sub>L</sub> = the inductor DC resistance (6)

Minimum inductor size needed when operating in minimum on-time mode is given by Equation 7:

$$L_{\text{MIN}} = \frac{(V_{\text{IN}} - V_{\text{OUT}} - I_{\text{OUT}} \times R_{\text{DS,ON}} - R_{\text{L}} \times I_{\text{OUT}}) \times t_{\text{ON,MIN}}}{\Delta I_{\text{L}}} \quad (7)$$

Minimum inductor size needed when operating in minimum off-time mode is given by [Equation 8](#):

$$L_{\text{MIN}} = \frac{(V_{\text{OUT}} + V_{\text{SCHOTTKY}} + R_{\text{L}} \times I_{\text{OUT}}) \times t_{\text{OFF,MIN}}}{\Delta I_{\text{L}}}$$

where

- $\Delta I_{\text{L}} = (20\% - 30\%) \times I_{\text{OUT-MAX}}$  (8)

### 8.2.2.3 External PMOS Transistor Selection (Buck Controllers)

The external PMOS transistor is selected based on threshold voltage ( $V_{\text{T}}$ ), on-resistance ( $R_{\text{DS,ON}}$ ), gate capacitance ( $C_{\text{G}}$ ) and voltage rating. The PMOS  $V_{\text{T}}$  magnitude must be much lower than the lowest voltage at IN1 or IN2 that will be used. A  $V_{\text{T}}$  magnitude that is 0.5V less than the lowest input voltage is normally sufficient. The PMOS gate will see voltages from 0V to the maximum input voltage, so gate-to-source breakdown should be a few volts higher than the maximum input supply. The drain-to-source of the device will also see this full voltage swing, and should therefore be a few volts higher than the maximum input supply. The RMS current in the PMOS can be estimated by using [Equation 9](#):

$$I_{\text{PMOS(RMS)}} \approx I_{\text{OUT}} \sqrt{D} = I_{\text{OUT}} \sqrt{\frac{V_{\text{OUT}}}{V_{\text{IN}}}} \quad (9)$$

The power dissipated in the PMOS is comprised of both conduction and switching losses. Switching losses are typically insignificant. The conduction losses are a function of the RMS current and the  $R_{\text{DS,ON}}$  of the PMOS, and are calculated by [Equation 10](#):

$$P_{(\text{cond})} = (I_{\text{OUT}} \sqrt{D})^2 \times R_{\text{DS,ON}} \times (1 + \text{TC} \times [T_{\text{J}} - 25^{\circ}\text{C}]) \approx (I_{\text{OUT}} \sqrt{D}) \times R_{\text{DS,ON}} \quad (10)$$

### 8.2.2.4 Diode Selection (Buck Controllers)

The diode is off when the PMOS is on, and on when the PMOS is off. Since it will be turned on and off at a relatively high frequency, a Schottky diode is recommended for good performance. The peak current rating of the diode should exceed the peak current limit set by the sense resistor  $R_{\text{IS1,2}}$ . A diode with low reverse leakage current and low forward voltage at operating current will optimize efficiency. [Equation 11](#) calculates the estimated average power dissipation:

$$I_{(\text{diode})(\text{RMS})} \approx I_{\text{OUT}} (1 - D) = I_{\text{OUT}} \left( 1 - \frac{V_{\text{OUT}}}{V_{\text{IN}}} \right) \quad (11)$$

### 8.2.2.5 Output Capacitor Selection (Buck Controllers)

The output capacitor is selected based on output voltage ripple and transient response requirements. As a result of the nature of the hysteretic control loop, a minimum ESR of a few tens of mΩ should be maintained for good operation unless a feed-forward resistor is used. Low ESR bulk tantalum or PosCap capacitors work best in most applications. A 1.0μF ceramic capacitor can be used in parallel with this capacitor to filter higher frequency spikes. The output voltage ripple can be estimated by [Equation 12](#):

$$\Delta V_{\text{PP}} = \Delta I \times \left[ \text{ESR} + \left( \frac{1}{8 \times C_{\text{OUT}} \times f} \right) \right] \approx 1.1 \Delta I \times \text{ESR} \quad (12)$$

To calculate the capacitance needed to achieve a given voltage ripple as a result of a load transient from zero output to full current, use [Equation 13](#):

$$C_{\text{OUT}} = \frac{L \times \Delta I_{\text{OUT}}^2}{(V_{\text{IN}} - V_{\text{OUT}}) \times \Delta V} \quad (13)$$

If only ceramic or other very low ESR output capacitor configurations are desired, additional voltage ripple must be passed to the feedback pin. For detailed application information, refer to the [Using Ceramic Output Capacitors with the TPS6420x and TPS75003 Buck Controllers](#) application report.

### 8.2.2.6 Output Voltage Ripple Effect on $V_{OUT}$ (Buck Controllers)

Output voltage ripple causes  $V_{OUT}$  to be higher or lower than the target value by half of the peak-to-peak voltage ripple. For minimum on-time, the ripple adds to the voltage; for minimum off-time, it subtracts from the voltage.

### 8.2.2.7 Soft-Start Capacitor Selection (Buck Controllers)

The soft-start for BUCK1 and BUCK2 is not intended to be a precision function. However, the startup time (from a positive transition on Enable to  $V_{OUT}$  reaching its final value) has a linear relationship to  $C_{SS}$  up to approximately 800pF, which results in a startup time of approximately 4ms. Above this value of  $C_{SS}$ , the variation in start-up time increases rapidly. This variation can occur from unit to unit and even between the two BUCK controllers in one device. Therefore, do not depend on the soft-start feature for sequencing multiple supplies if values of  $C_{SS}$  greater than 800pF are used.

BUCK1 is discussed in this section; it is identical to BUCK2. Soft-start is implemented on the buck controllers by ramping current limit from 0 to its target value (set by  $R_1$ ) over a user-defined time. This time is set by the external soft-start cap connected to pin SS1. If SS1 is left open, a small on-chip capacitor will provide a current limit ramp time of approximately 250 $\mu$ s. [Figure 19](#) shows the effects of  $R_1$  and SS1 on the current limit start-up ramp.

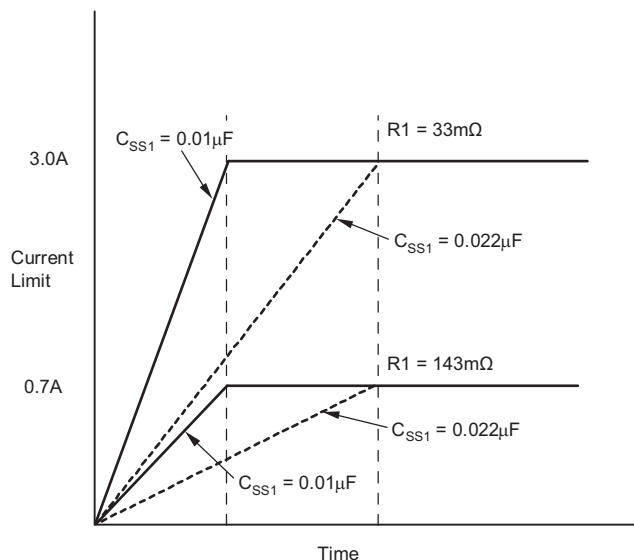

**Figure 19. Effects of  $C_{SS1}$  and  $R_1$  on Current Ramp Limit**

This soft-start current limit ramp can be used to provide inrush current control or output voltage ramp control. While the current limit ramp can be easily understood by looking at [Figure 19](#), the output voltage ramp is a complex function of many variables. The dominant variables in this process are  $V_{OUT1}$ ,  $C_{SS1}$ ,  $I_{OUT1}$ , and  $R_1$ . Less important variables are  $V_{IN1}$  and  $L_1$ .

The best way to set a target start-up time is through bench measurement under target conditions, adjusting  $C_{SS1}$  to get the desired startup profile. To stay above a minimum start-up time, set the nominal start-up time to approximately five times the minimum. To stay below a maximum time, set the nominal start-up time at one-fifth of the maximum. Fastest start-up times occur at maximum  $V_{IN1}$ , with minimum  $V_{OUT1}$ ,  $L_1$ ,  $C_{OUT1}$ ,  $C_{SS1}$ , and  $I_{OUT1}$ . Slowest start-up times occur under opposite conditions.

Refer to [Figure 21](#) to [Figure 25](#) for characterization curves showing how the start-up profile is affected by these critical parameters.

### 8.2.2.8 Output Voltage Setting Selection (Buck Controllers)

Output voltage is set using two resistors as shown for Buck2 in [Figure 18](#). Output voltage is then calculated using [Equation 14](#):

$$V_{OUT} = V_{FB} \left( \frac{R5}{R6} + 1 \right)$$

where

- $V_{FB} = 1.22V$  (14)

### 8.2.2.9 Input Capacitor Selection (LDO)

Although an input capacitor is not required, it is good analog design practice to connect a 0.1μF to 10μF low ESR capacitor across the input supply near the regulator. This capacitor counteracts reactive input sources and improves transient response, stability, and ripple rejection. A higher value capacitor may be needed if large, fast rise-time load transients are anticipated, or if the device is located far from its power source.

### 8.2.2.10 Output Capacitor Selection (LDO)

A 2.2μF or greater capacitor is required near the output of the device to ensure stability. The LDO is stable with any capacitor type, including ceramic. If improved transient response or ripple rejection is required, larger and/or lower ESR output capacitors can be used.

### 8.2.2.11 Soft-Start Capacitor Selection (LDO)

The LDO uses an external soft-start capacitor,  $C_{SS3}$ , to provide an RC-ramped reference voltage to the control loop. See the [Functional Block Diagram](#). This is a voltage-controlled soft-start, as compared to the current-controlled soft-start used by the buck controllers. The start-up waveform can be approximated by [Equation 15](#):

$$V_{OUT}(t) = V_{OUT,SET} \left( 1 - e^{-\frac{t}{RC}} \right)$$

where

- $R = 480 \times 10^3$
- $C =$  capacitance in μF from SS3 to GND (15)

The time taken to reach 90% of final  $V_{OUT}$  can be approximated by [Equation 16](#):

$$T_{90\%} = 2.3 \times (480 \times 10^3) C_{SS3} (\mu F) \quad (16)$$

### 8.2.2.12 Setting Output Voltage (LDO)

Output voltage is set using two resistors as shown in [Figure 18](#). Output voltage is then calculated using [Equation 17](#):

$$V_{OUT} = V_{FB} \left( \frac{R3}{R4} + 1 \right)$$

where

- $V_{FB} = 0.507V$  (17)

8.2.3 Application Curves

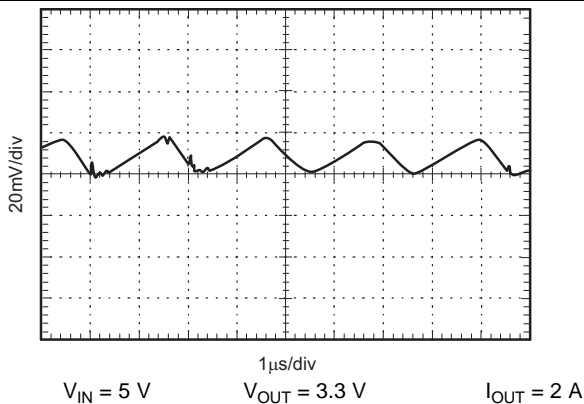
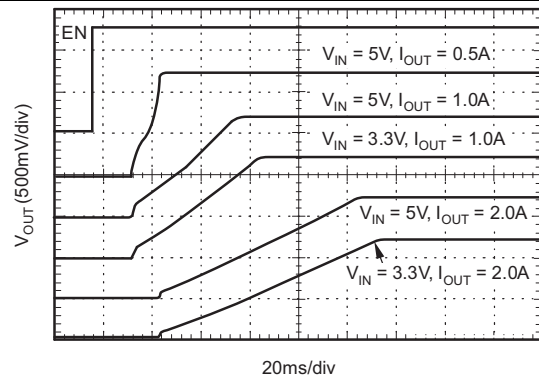

Figure 20. Buck Output Voltage Ripple



See the [Soft-Start Capacitor Selection \(Buck Controllers\)](#) section.

$V_{OUT} = 1.2\text{ V}$        $C_{SS} = 0.01\text{ }\mu\text{F}$

Figure 21. Buck Start-Up vs  $V_{IN}$  and  $I_{OUT}$

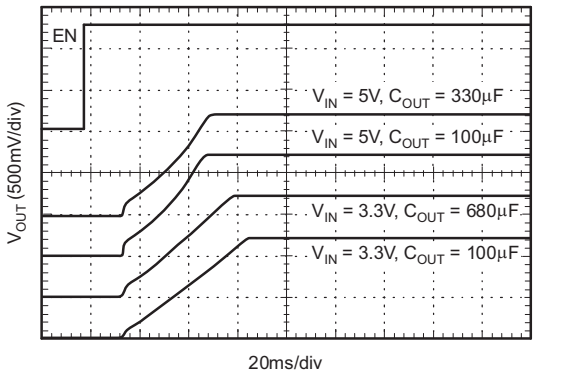

See the [Soft-Start Capacitor Selection \(Buck Controllers\)](#) section.

$V_{OUT} = 1.2\text{ V}$        $C_{SS} = 0.01\text{ }\mu\text{F}$

Figure 22. Buck Start-Up vs  $V_{IN}$  and  $C_{OUT}$

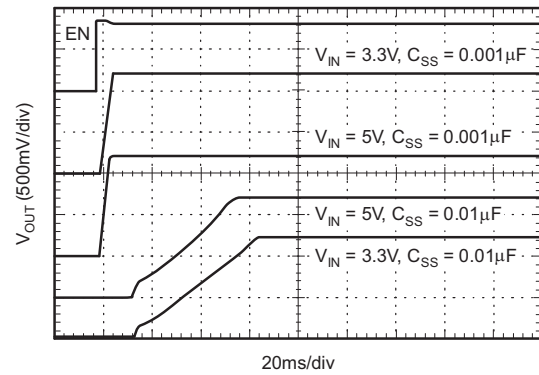

See the [Soft-Start Capacitor Selection \(Buck Controllers\)](#) section.

$V_{OUT} = 1.2\text{ V}$        $I_{OUT} = 1\text{ A}$

Figure 23. Buck Start-Up vs  $V_{IN}$  and  $C_{SS}$

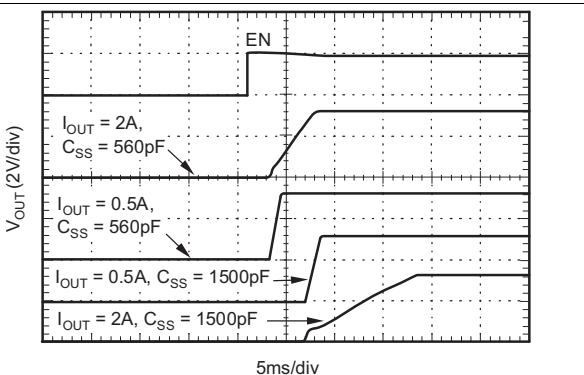

See the [Soft-Start Capacitor Selection \(Buck Controllers\)](#) section.

$V_{IN} = 5\text{ V}$        $V_{OUT} = 3.3\text{ V}$

Figure 24. Buck Start-Up vs  $I_{OUT}$  and  $C_{SS}$

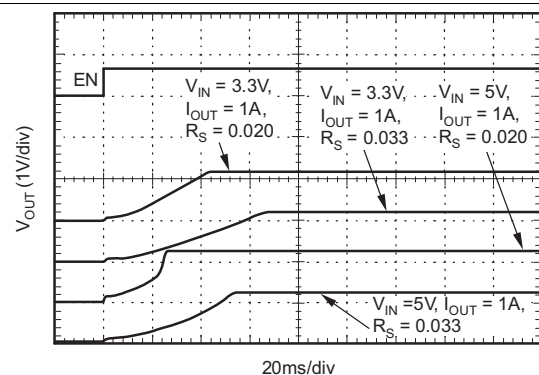

See the [Soft-Start Capacitor Selection \(Buck Controllers\)](#) section.

$V_{OUT} = 1.2\text{ V}$        $C_{SS} = 0.01\text{ }\mu\text{F}$

Figure 25. Buck Start-Up vs  $V_{IN}$  and  $R_{SENSE}$

## 9 Power Supply Recommendations

There are three separate blocks internal to the TPS75003 device: two identical buck controllers and one integrated LDO regulator. The input voltage,  $V_{INX}$ , to the IN1 and IN2 pins must be within the range specified in the [Electrical Characteristics](#) and must be greater than the nominal output voltage of BUCK1 or BUCK2, respectively. However, the maximum output voltages,  $V_{OUT1}$  and  $V_{OUT2}$ , are determined by external component selection and cannot be specified. The input voltage to the LDO regulator,  $V_{IN3}$ , must be greater than the drop-out voltage ( $V_{DO}$ ) added to  $V_{OUT3}$  or an absolute value of 2.2 V, whichever is greater. The power supply into the IN1, IN2, and IN3 pins do not need to be equal to each other but all of the design values must adhere to the minimum and maximum specifications of the TPS75003 and external components. Other considerations are based on the relationship of pins used inside the TPS75003 device.

The power supply into IN1 is used as the power supply to drive the gate of the switch connected at SW1. The difference between the voltages at the IN1 pin and IS1 pin is the input to the sensing which controls current limit. The power supply connected at IN1 must be the power supply connected to 33-m $\Omega$  sense resistor, and the opposite terminal of the sense resistor must connect directly to IS1 and the source pin(s) of the external PMOS FET.

Similarly, the power supply into IN2 is used as the power supply to drive the gate of the switch connected at SW2. The difference between the voltages at the IN2 pin and IS2 pin is the input to the sensing which controls current limit. The power supply connected at IN2 must be the power supply connected to 33-m $\Omega$  sense resistor, and the opposite terminal of the sense resistor must connect directly to IS2 and the source pins of the external PMOS FET.

The power supply into IN3 is used as the power supply to the LDO regulator and all internal support circuitry. Unlike the BUCK1 and BUCK2 controllers, the power does not bypass the TPS75003 device. Therefore, the output of the LDO is named OUT3 and up to 300-mA of current will go directly from IN3 to OUT3.

## 10 Layout

### 10.1 Layout Guidelines

#### 10.1.1 PCB Layout Considerations

As with any switching regulators, careful attention must be paid to board layout. A typical application circuit and corresponding recommended printed circuit board (PCB) layout with emphasis on the most sensitive areas are shown in Figure 26 through Figure 28.

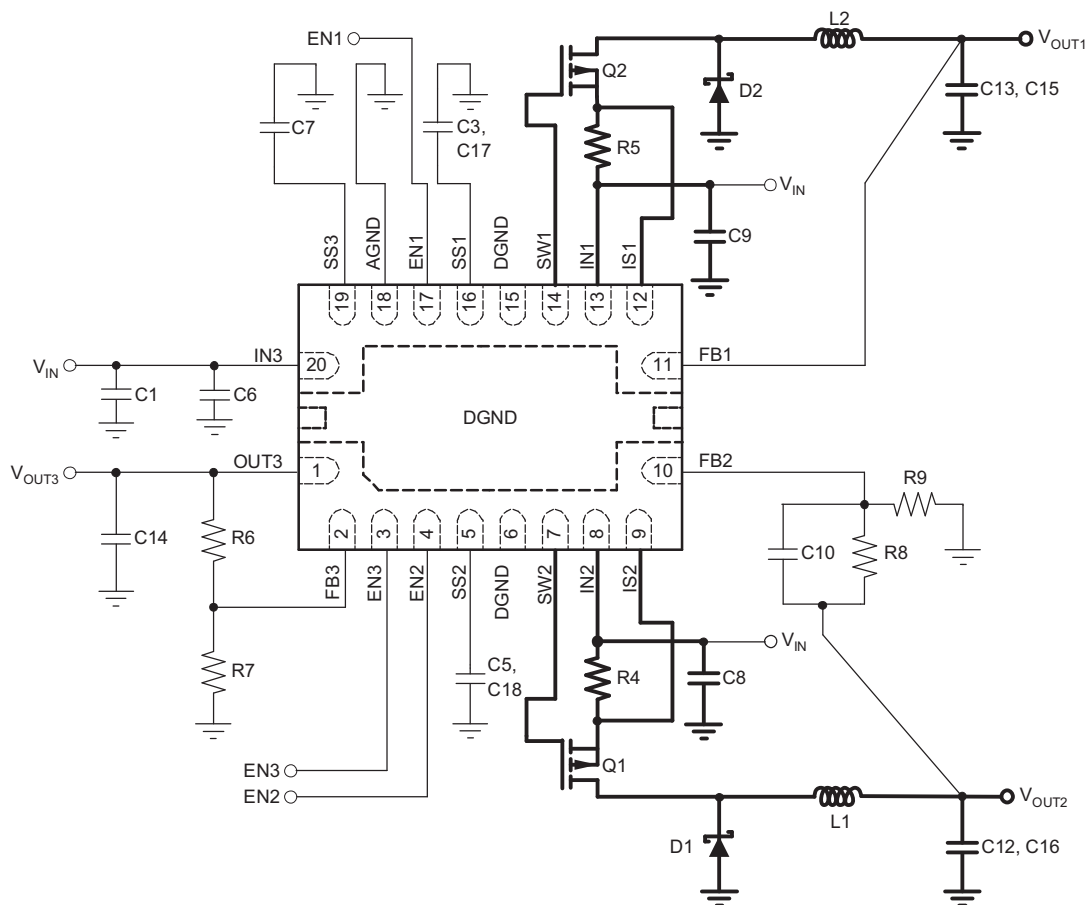

Note: Most sensitive areas are highlighted by bold lines.

Figure 26. Typical Application Circuit

## 10.2 Layout Example

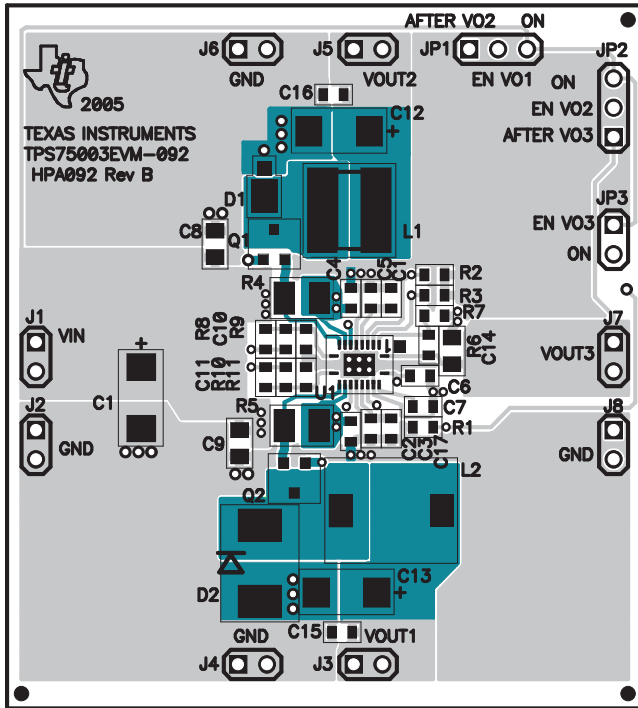

Most sensitive areas are highlighted in green.

**Figure 27. Recommended PCB Layout, Component Side, Top View**

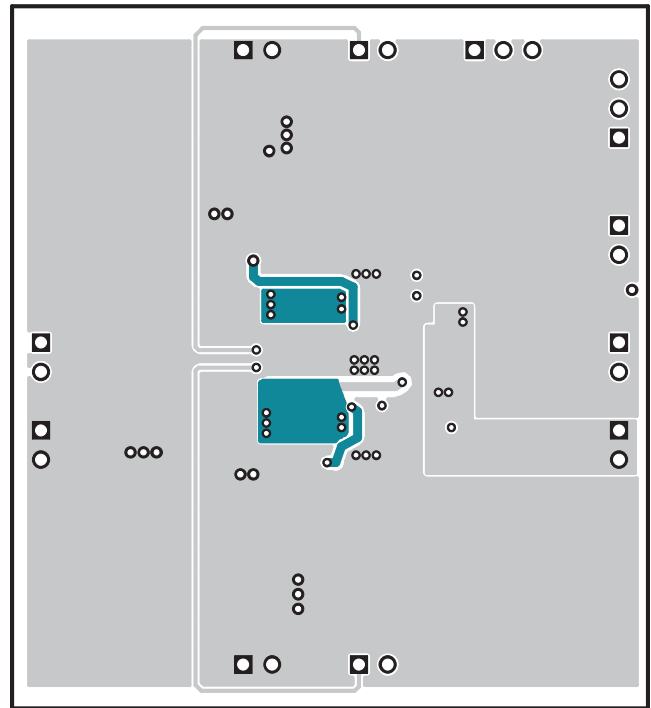

Most sensitive areas are highlighted in green.

**Figure 28. Recommended PCB Layout, Bottom Side, Top View**

## 11 Device and Documentation Support

### 11.1 Device Support

#### 11.1.1 Third-Party Products Disclaimer

TI'S PUBLICATION OF INFORMATION REGARDING THIRD-PARTY PRODUCTS OR SERVICES DOES NOT CONSTITUTE AN ENDORSEMENT REGARDING THE SUITABILITY OF SUCH PRODUCTS OR SERVICES OR A WARRANTY, REPRESENTATION OR ENDORSEMENT OF SUCH PRODUCTS OR SERVICES, EITHER ALONE OR IN COMBINATION WITH ANY TI PRODUCT OR SERVICE.

#### 11.1.2 Development Support

For development support, refer to:

- [Design Spreadsheet for the TPS75003](#)
- [TPS75003: Gerber Software for TPS75003](#)

### 11.2 Documentation Support

#### 11.2.1 Related Documentation

For related documentation see the following:

- Texas Instruments, [TPS75003EVM User's Guide](#)
- Texas Instruments, [Using 3.3-V Signals for Spartan-3 Configuration and JTAG Ports application note](#)
- Texas Instruments, [Using Ceramic Output Capacitors with the TPS6420x and TPS75003 Buck Controllers application report](#)

### 11.3 Receiving Notification of Documentation Updates

To receive notification of documentation updates, navigate to the device product folder on ti.com. In the upper right corner, click on *Alert me* to register and receive a weekly digest of any product information that has changed. For change details, review the revision history included in any revised document.

### 11.4 Community Resources

The following links connect to TI community resources. Linked contents are provided "AS IS" by the respective contributors. They do not constitute TI specifications and do not necessarily reflect TI's views; see TI's [Terms of Use](#).

**TI E2E™ Online Community** *TI's Engineer-to-Engineer (E2E) Community*. Created to foster collaboration among engineers. At e2e.ti.com, you can ask questions, share knowledge, explore ideas and help solve problems with fellow engineers.

**Design Support** *TI's Design Support* Quickly find helpful E2E forums along with design support tools and contact information for technical support.

### 11.5 Trademarks

E2E is a trademark of Texas Instruments.

Spartan is a trademark of Xilinx, Inc.

All other trademarks are the property of their respective owners.

### 11.6 Electrostatic Discharge Caution



This integrated circuit can be damaged by ESD. Texas Instruments recommends that all integrated circuits be handled with appropriate precautions. Failure to observe proper handling and installation procedures can cause damage.

ESD damage can range from subtle performance degradation to complete device failure. Precision integrated circuits may be more susceptible to damage because very small parametric changes could cause the device not to meet its published specifications.

### 11.7 Glossary

[SLYZ022](#) — *TI Glossary*.

This glossary lists and explains terms, acronyms, and definitions.

## 12 Mechanical, Packaging, and Orderable Information

The following pages include mechanical, packaging, and orderable information. This information is the most current data available for the designated devices. This data is subject to change without notice and revision of this document. For browser-based versions of this data sheet, refer to the left-hand navigation.

**PACKAGING INFORMATION**

Orderable Device	Status (1)	Package Type	Package Drawing	Pins	Package Qty	Eco Plan (2)	Lead finish/ Ball material (6)	MSL Peak Temp (3)	Op Temp (°C)	Device Marking (4/5)	Samples
TPS75003RHLLR	ACTIVE	VQFN	RHL	20	3000	RoHS & Green	NIPDAU	Level-1-260C-UNLIM	-40 to 85	75003	<a href="#">Samples</a>
TPS75003RHLLRG4	ACTIVE	VQFN	RHL	20	3000	RoHS & Green	NIPDAU	Level-1-260C-UNLIM	-40 to 85	75003	<a href="#">Samples</a>
TPS75003RHLLT	ACTIVE	VQFN	RHL	20	250	RoHS & Green	NIPDAU	Level-1-260C-UNLIM	-40 to 85	75003	<a href="#">Samples</a>
TPS75003RHLLTG4	ACTIVE	VQFN	RHL	20	250	RoHS & Green	NIPDAU	Level-1-260C-UNLIM	-40 to 85	75003	<a href="#">Samples</a>

(1) The marketing status values are defined as follows:

**ACTIVE:** Product device recommended for new designs.

**LIFEBUY:** TI has announced that the device will be discontinued, and a lifetime-buy period is in effect.

**NRND:** Not recommended for new designs. Device is in production to support existing customers, but TI does not recommend using this part in a new design.

**PREVIEW:** Device has been announced but is not in production. Samples may or may not be available.

**OBSELETE:** TI has discontinued the production of the device.

(2) **RoHS:** TI defines "RoHS" to mean semiconductor products that are compliant with the current EU RoHS requirements for all 10 RoHS substances, including the requirement that RoHS substance do not exceed 0.1% by weight in homogeneous materials. Where designed to be soldered at high temperatures, "RoHS" products are suitable for use in specified lead-free processes. TI may reference these types of products as "Pb-Free".

**RoHS Exempt:** TI defines "RoHS Exempt" to mean products that contain lead but are compliant with EU RoHS pursuant to a specific EU RoHS exemption.

**Green:** TI defines "Green" to mean the content of Chlorine (Cl) and Bromine (Br) based flame retardants meet JS709B low halogen requirements of <=1000ppm threshold. Antimony trioxide based flame retardants must also meet the <=1000ppm threshold requirement.

(3) MSL, Peak Temp. - The Moisture Sensitivity Level rating according to the JEDEC industry standard classifications, and peak solder temperature.

(4) There may be additional marking, which relates to the logo, the lot trace code information, or the environmental category on the device.

(5) Multiple Device Markings will be inside parentheses. Only one Device Marking contained in parentheses and separated by a "-" will appear on a device. If a line is indented then it is a continuation of the previous line and the two combined represent the entire Device Marking for that device.

(6) Lead finish/Ball material - Orderable Devices may have multiple material finish options. Finish options are separated by a vertical ruled line. Lead finish/Ball material values may wrap to two lines if the finish value exceeds the maximum column width.

**Important Information and Disclaimer:**The information provided on this page represents TI's knowledge and belief as of the date that it is provided. TI bases its knowledge and belief on information provided by third parties, and makes no representation or warranty as to the accuracy of such information. Efforts are underway to better integrate information from third parties. TI has taken and

continues to take reasonable steps to provide representative and accurate information but may not have conducted destructive testing or chemical analysis on incoming materials and chemicals. TI and TI suppliers consider certain information to be proprietary, and thus CAS numbers and other limited information may not be available for release.

In no event shall TI's liability arising out of such information exceed the total purchase price of the TI part(s) at issue in this document sold by TI to Customer on an annual basis.

**OTHER QUALIFIED VERSIONS OF TPS75003 :**

- Enhanced Product: [TPS75003-EP](#)

NOTE: Qualified Version Definitions:

- Enhanced Product - Supports Defense, Aerospace and Medical Applications

**TAPE AND REEL INFORMATION**

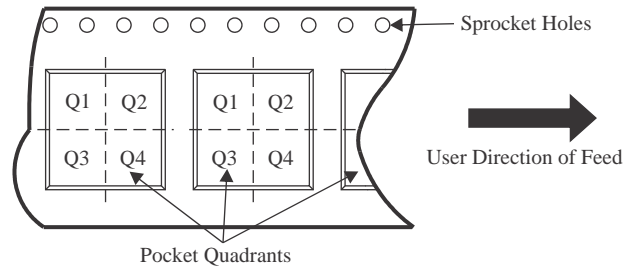
**QUADRANT ASSIGNMENTS FOR PIN 1 ORIENTATION IN TAPE**

\*All dimensions are nominal

Device	Package Type	Package Drawing	Pins	SPQ	Reel Diameter (mm)	Reel Width W1 (mm)	A0 (mm)	B0 (mm)	K0 (mm)	P1 (mm)	W (mm)	Pin1 Quadrant
TPS75003RHLR	VQFN	RHL	20	3000	330.0	12.4	3.8	4.8	1.6	8.0	12.0	Q1
TPS75003RHLT	VQFN	RHL	20	250	180.0	12.4	3.8	4.8	1.6	8.0	12.0	Q1

**TAPE AND REEL BOX DIMENSIONS**

\*All dimensions are nominal

Device	Package Type	Package Drawing	Pins	SPQ	Length (mm)	Width (mm)	Height (mm)
TPS75003RHRLR	VQFN	RHL	20	3000	356.0	356.0	35.0
TPS75003RHILT	VQFN	RHL	20	250	210.0	185.0	35.0

## GENERIC PACKAGE VIEW

**RHL 20**

**VQFN - 1 mm max height**

**3.5 x 4.5 mm, 0.5 mm pitch**

PLASTIC QUAD FLATPACK - NO LEAD

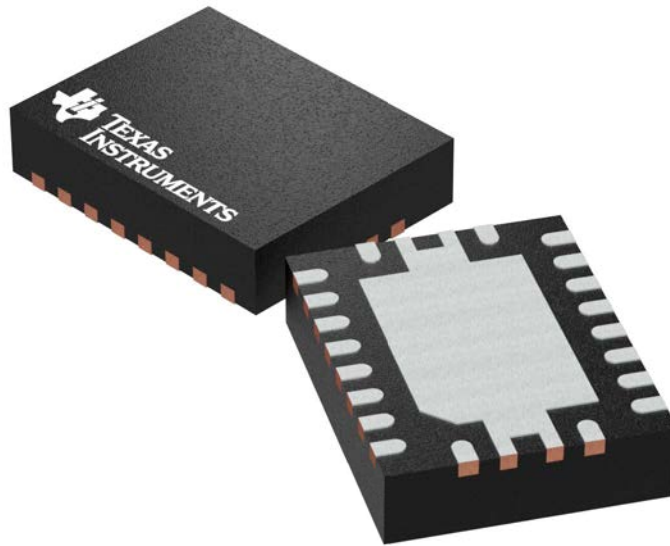

Images above are just a representation of the package family, actual package may vary.  
Refer to the product data sheet for package details.

4205346/L



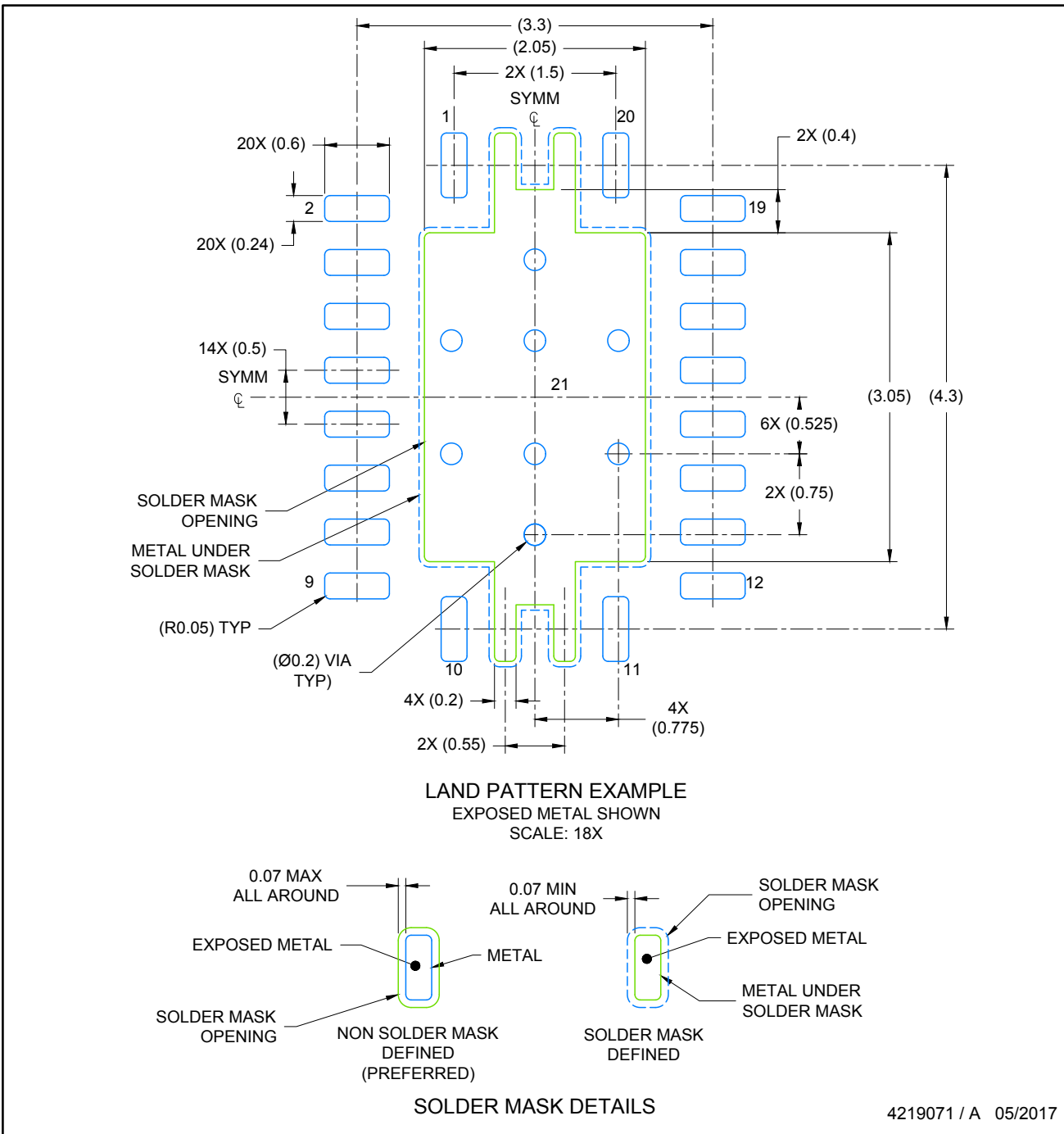

NOTES: (continued)

4. This package is designed to be soldered to a thermal pad on the board. For more information, see Texas Instruments literature number SLUA271 ([www.ti.com/lit/slua271](http://www.ti.com/lit/slua271)).
5. Solder mask tolerances between and around signal pads can vary based on board fabrication site.
6. Vias are optional depending on application, refer to device data sheet. If any vias are implemented, refer to their locations shown on this view. It is recommended that vias under paste be filled, plugged or tented.

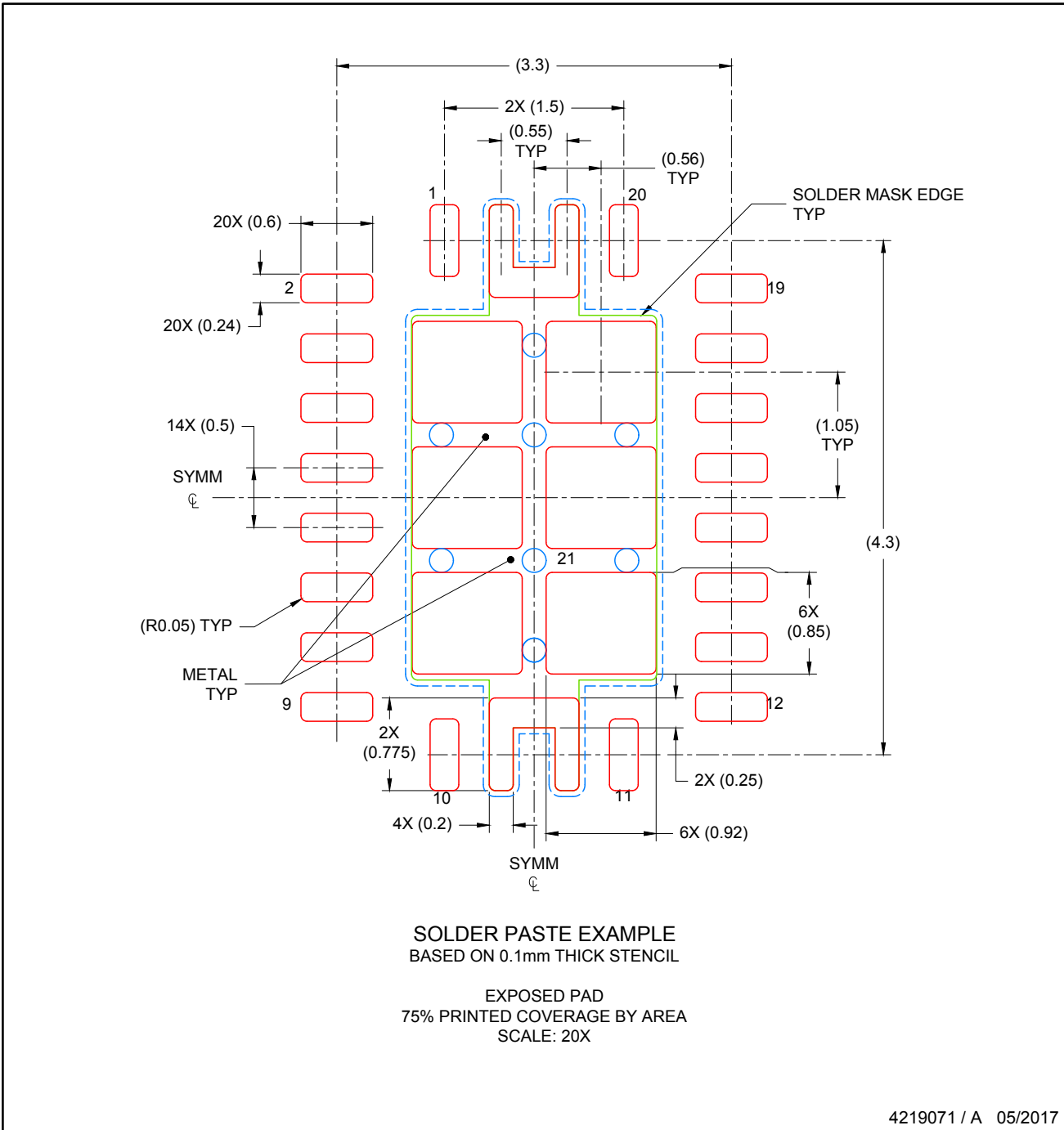

NOTES: (continued)

7. Laser cutting apertures with trapezoidal walls and rounded corners may offer better paste release. IPC-7525 may have alternate design recommendations..

## IMPORTANT NOTICE AND DISCLAIMER

TI PROVIDES TECHNICAL AND RELIABILITY DATA (INCLUDING DATA SHEETS), DESIGN RESOURCES (INCLUDING REFERENCE DESIGNS), APPLICATION OR OTHER DESIGN ADVICE, WEB TOOLS, SAFETY INFORMATION, AND OTHER RESOURCES "AS IS" AND WITH ALL FAULTS, AND DISCLAIMS ALL WARRANTIES, EXPRESS AND IMPLIED, INCLUDING WITHOUT LIMITATION ANY IMPLIED WARRANTIES OF MERCHANTABILITY, FITNESS FOR A PARTICULAR PURPOSE OR NON-INFRINGEMENT OF THIRD PARTY INTELLECTUAL PROPERTY RIGHTS.

These resources are intended for skilled developers designing with TI products. You are solely responsible for (1) selecting the appropriate TI products for your application, (2) designing, validating and testing your application, and (3) ensuring your application meets applicable standards, and any other safety, security, regulatory or other requirements.

These resources are subject to change without notice. TI grants you permission to use these resources only for development of an application that uses the TI products described in the resource. Other reproduction and display of these resources is prohibited. No license is granted to any other TI intellectual property right or to any third party intellectual property right. TI disclaims responsibility for, and you will fully indemnify TI and its representatives against, any claims, damages, costs, losses, and liabilities arising out of your use of these resources.

TI's products are provided subject to [TI's Terms of Sale](#) or other applicable terms available either on [ti.com](http://ti.com) or provided in conjunction with such TI products. TI's provision of these resources does not expand or otherwise alter TI's applicable warranties or warranty disclaimers for TI products.

TI objects to and rejects any additional or different terms you may have proposed.

Mailing Address: Texas Instruments, Post Office Box 655303, Dallas, Texas 75265  
Copyright © 2022, Texas Instruments Incorporated

## Looking for pricing, stock, or lifecycle information?

Click below to explore more details on WIN SOURCE:

 [View TPS75003RHLT on WIN SOURCE](#)

 [Texas Instruments](#) Information

## Optimize Your Supply Chain with WIN SOURCE Solutions

-  Global Sourcing Solution
-  Obsolete Management
-  Cost Control Management
-  Shortage Management
-  Alternative Solution
-  Excess Inventory Management