



**THE DATASHEET OF  
TPS7A6201QKTTRQ1**



# TPS7A6201-Q1 300-mA, 40-V, Low-Dropout Regulator With 25- $\mu$ A Quiescent Current

## 1 Features

- AEC-Q100 qualified for automotive applications:
  - Temperature grade 1:  $-40^{\circ}\text{C}$  to  $125^{\circ}\text{C}$ ,  $T_A$
  - Junction Temperature:  $-40^{\circ}\text{C}$  to  $150^{\circ}\text{C}$ ,  $T_J$
- Low dropout voltage:
  - 300 mV at  $I_{OUT} = 150$  mA
- 7-V to 40-V wide input voltage range with up to 45-V transients
- 300-mA maximum output current
- Ultra-low quiescent current:
  - $I_{QUIESCENT} = 25$   $\mu\text{A}$  (typical) at light loads
  - $I_{SLEEP} < 2$   $\mu\text{A}$  when EN = Low
- 2.5-V to 7-V adjustable output voltage
- Low-ESR ceramic output stability capacitor
- Integrated fault protection:
  - Short-circuit and overcurrent protection
  - Thermal shutdown
- Low input voltage tracking
- Thermally enhanced power package:
  - 5-pin TO-263 (KTT, D2PAK)

## 2 Applications

- [Automotive head units](#)
- [Battery management systems \(BMS\)](#)
- [Hybrid instrument clusters](#)

## 3 Description

The TPS7A6201-Q1 is a low-dropout linear voltage regulator designed for low power consumption and quiescent current less than 25  $\mu\text{A}$  in light-load applications. This device features an integrated over-current protection, and is designed to achieve stable operation even with low-ESR ceramic output capacitors. The output voltage can be programmed using external resistors. The low-voltage tracking feature allows for a smaller input capacitor and can possibly eliminate the need of using a boost converter during cold crank conditions. Because of these features, this device is well suited in power supplies for various automotive applications.

### Device Information<sup>(1)</sup>

PART NUMBER	PACKAGE	BODY SIZE (NOM)
TPS7A6201-Q1	TO-263 (5)	10.16 mm x 8.42 mm

(1) For all available packages, see the orderable addendum at the end of the data sheet.

### Typical Regulator Stability

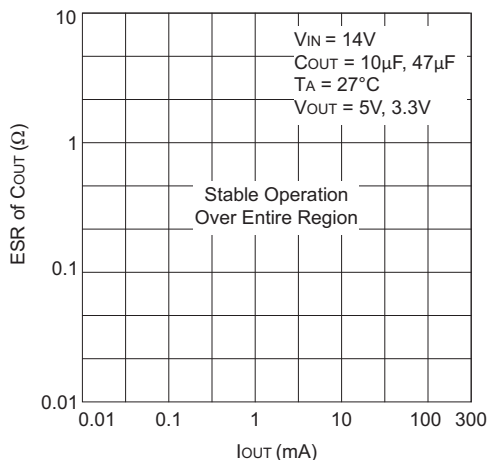

### Application Schematic

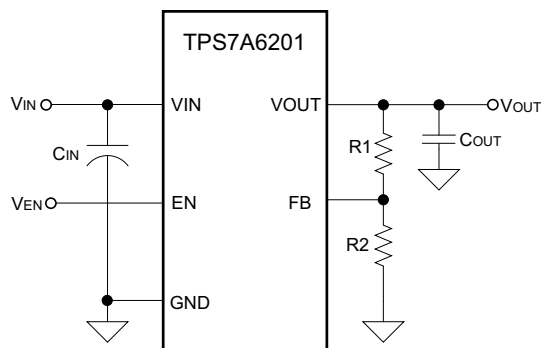

## Table of Contents

<b>1 Features</b> .....	<b>1</b>	7.4 Device Functional Modes.....	<b>14</b>
<b>2 Applications</b> .....	<b>1</b>	<b>8 Application and Implementation</b> .....	<b>14</b>
<b>3 Description</b> .....	<b>1</b>	8.1 Application Information.....	<b>14</b>
<b>4 Revision History</b> .....	<b>2</b>	8.2 Typical Application .....	<b>15</b>
<b>5 Pin Configuration and Functions</b> .....	<b>4</b>	<b>9 Power Supply Recommendations</b> .....	<b>16</b>
<b>6 Specifications</b> .....	<b>4</b>	<b>10 Layout</b> .....	<b>17</b>
6.1 Absolute Maximum Ratings .....	<b>4</b>	10.1 Layout Guidelines .....	<b>17</b>
6.2 ESD Ratings.....	<b>4</b>	10.2 Layout Example .....	<b>19</b>
6.3 Recommended Operating Conditions.....	<b>5</b>	<b>11 Device and Documentation Support</b> .....	<b>20</b>
6.4 Thermal Information .....	<b>5</b>	11.1 Receiving Notification of Documentation Updates	<b>20</b>
6.5 Electrical Characteristics.....	<b>5</b>	11.2 Community Resources.....	<b>20</b>
6.6 Typical Characteristics .....	<b>7</b>	11.3 Trademarks .....	<b>20</b>
<b>7 Detailed Description</b> .....	<b>10</b>	11.4 Electrostatic Discharge Caution.....	<b>20</b>
7.1 Overview .....	<b>10</b>	11.5 Glossary .....	<b>20</b>
7.2 Functional Block Diagram .....	<b>10</b>	<b>12 Mechanical, Packaging, and Orderable</b>	
7.3 Feature Description.....	<b>11</b>	<b>Information</b> .....	<b>20</b>

## 4 Revision History

NOTE: Page numbers for previous revisions may differ from page numbers in the current version.

### Changes from Revision D (May 2018) to Revision E

Page

• Changed AEC-Q100 <i>Features</i> bullets to conform to new standard .....	<b>1</b>
• Changed input voltage range from 11 V to 7 V throughout document .....	<b>1</b>
• Changed <i>Applications</i> section .....	<b>1</b>
• Added footnote to $V_{IN}$ row in <i>Recommended Operating Conditions</i> table .....	<b>5</b>
• Added footnote to $V_{IN}$ row in <i>Electrical Characteristics</i> table .....	<b>5</b>
• Deleted <i>Dissipation Ratings</i> table.....	<b>6</b>

### Changes from Revision C (July 2016) to Revision D

Page

• Changed 4 V to 11 V in fourth <i>Features</i> bullet .....	<b>1</b>
• Changed <i>Programmable</i> to <i>Adjustable</i> in <i>Output Voltage Features</i> bullet .....	<b>1</b>
• Changed $V_{IN}$ , $V_{EN}$ parameter row in <i>Recommended Operating Conditions</i> table: separated $V_{IN}$ and $V_{EN}$ into different rows, changed $V_{IN}$ minimum specification from 4 V to 11 V .....	<b>5</b>
• Changed $V_{IN}$ parameter minimum specification from 4 V to 11 V in <i>Electrical Characteristics</i> table.....	<b>5</b>
• Changed 4 V to 11 V in <i>Input voltage range</i> row of <i>Design Parameters</i> table .....	<b>15</b>
• Changed 4 V to 11 V in first sentence of <i>Power Supply Recommendations</i> section.....	<b>16</b>

### Changes from Revision B (March 2012) to Revision C

Page

• Added <i>ESD Ratings</i> table, <i>Feature Description</i> section, <i>Device Functional Modes</i> , <i>Application and Implementation</i> section, <i>Power Supply Recommendations</i> section, <i>Layout</i> section, <i>Device and Documentation Support</i> section, and <i>Mechanical, Packaging, and Orderable Information</i> section. ....	<b>1</b>
• Removed <i>Ordering Information</i> table, see POA at the end of the data sheet .....	<b>1</b>
• Changed <i>Thermal Information</i> table .....	<b>5</b>

**Changes from Revision A (December 2011) to Revision B****Page**

- 
- Added value to test conditions field in Regulated Output Voltage 6.1 ( $I_{OUT} = 10 \text{ mA to } 300 \text{ mA}$ ,  $V_{IN} = V_{OUT} + 1 \text{ V to } 16 \text{ V}$ ) . **5**
-

## 5 Pin Configuration and Functions

KTTPackage  
5-Pin TO-263  
Top View

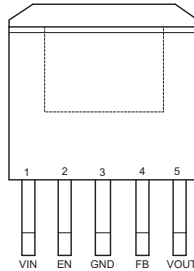

Pin Functions

PIN NO.	PIN NAME	I/O	DESCRIPTION
1	VIN	I	Input voltage pin: The unregulated input voltage is supplied to this pin. A bypass capacitor shall be connected between VIN pin and GND pin to dampen input line transients.
2	EN	I	Enable pin: This is a high voltage tolerant input pin with an internal pulldown. A high input to this pin activates the device and turns the regulator ON. This input can be connected to VIN terminal for self bias applications. If this pin is not connected, the device stays disabled.
3	GND	I/O	Ground pin: This is signal ground pin of the IC.
4	FB	I	Feedback pin: This pin is used to connect external resistors to ground to program the output voltage.
5	VOUT	O	Regulated output voltage pin: This is a regulated output voltage pin with a limitation on maximum output current. An external resistor divider is connected at this pin to program the output voltage. To achieve stable operation and prevent oscillation, an external output capacitor (C <sub>OUT</sub> ) with low ESR shall be connected between this pin and GND pin.

## 6 Specifications

### 6.1 Absolute Maximum Ratings

over operating free-air temperature range (unless otherwise noted)<sup>(1)</sup>

		MIN	MAX	UNIT
V <sub>IN</sub> , V <sub>EN</sub>	Unregulated inputs <sup>(2)</sup>	-0.3	45	V
V <sub>OUT</sub>	Regulated output		7	V
V <sub>FB</sub>	Feedback voltage	-0.3	7	V
T <sub>OP</sub>	Operating ambient temperature	-40	125	°C
T <sub>LEAD</sub>	Lead temperature (soldering, 10 s)		260	°C
T <sub>stg</sub>	Storage temperature	-65	150	°C

(1) Stresses beyond those listed under *Absolute Maximum Ratings* may cause permanent damage to the device. These are stress ratings only, and functional operation of the device at these or any other conditions beyond those indicated under *Recommended Operating Conditions* is not implied. Exposure to absolute-maximum-rated conditions for extended periods may affect device reliability. All voltage values are with respect to GND.

(2) Absolute maximum voltage for duration less than 480 ms.

### 6.2 ESD Ratings

		VALUE	UNIT	
V <sub>(ESD)</sub>	Electrostatic discharge	Human-body model (HBM), per ANSI/ESDA/JEDEC JS-001 <sup>(1)(2)</sup>	±2000	V

(1) JEDEC document JEP155 states that 500-V HBM allows safe manufacturing with a standard ESD control process.

(2) Tested in accordance with JEDEC Standard 22, Test Method A114-A (100-pF capacitor discharged through a 1.5-kΩ resistor into each pin).

### 6.3 Recommended Operating Conditions

		MIN	MAX	UNIT
$V_{IN}$	Unregulated input voltage	7 <sup>(1)</sup>	40	V
$V_{EN}$	Enable pin voltage	4	40	V
$T_J$	Operating junction temperature	-40	150	°C

- (1)  $V_{IN}$  can go down to 4 V for 130 ms or less and remain functional. If  $V_{IN}$  is less than 7 V for longer than 130 ms, then some devices may turn off until the input voltage rises above 7 V.

### 6.4 Thermal Information

THERMAL METRIC <sup>(1)</sup>		TPS7A6201-Q1		UNIT
		KTT (TO-263)		
		5 PINS		
$R_{\theta JA}$	Junction-to-ambient thermal resistance	High-K <sup>(2)</sup>	30.2	°C/W
		Low-K <sup>(3)</sup>	34.4	
$R_{\theta JC(top)}$	Junction-to-case (top) thermal resistance		38.9	°C/W
$R_{\theta JB}$	Junction-to-board thermal resistance		7.4	°C/W
$\psi_{JT}$	Junction-to-top characterization parameter		3.8	°C/W
$\psi_{JB}$	Junction-to-board characterization parameter		7.4	°C/W
$R_{\theta JC(bot)}$	Junction-to-case (bottom) thermal resistance		1.5	°C/W
$\theta_{JP}$	Thermal impedance junction to exposed pad KTT (D2PAK) package		10.4	°C/W

- (1) For more information about traditional and new thermal metrics, see the [Semiconductor and IC Package Thermal Metrics](#) application report.
- (2) The thermal data is based on JEDEC standard high K profile – JESD 51-5. The copper pad is soldered to the thermal land pattern. Also correct attachment procedure must be incorporated.
- (3) The thermal data is based on JEDEC standard low K profile – JESD 51-3. The copper pad is soldered to the thermal land pattern. Also correct attachment procedure must be incorporated.

### 6.5 Electrical Characteristics

$V_{IN} = 14$  V,  $T_J = -40$ °C to 150°C (unless otherwise noted)

PARAMETER		TEST CONDITIONS	MIN	TYP	MAX	UNIT
<b>INPUT VOLTAGE (VIN PIN)</b>						
$V_{IN}$	Input voltage		7 <sup>(1)</sup>		40	V
$I_{QUIESCENT}$	Quiescent current	$V_{IN} = 8.2$ V to 18 V, $V_{EN} = 5$ V, $I_{OUT} = 0.01$ mA to 0.75 mA		25	40	μA
$I_{SLEEP}$	Sleep/shutdown current	$V_{IN} = 8.2$ V to 18 V, $V_{EN} < 0.8$ V, $I_{OUT} = 0$ mA (no load), $T_A = 125$ °C			3	μA
$V_{IN-UVLO}$	Undervoltage lockout voltage	Ramp $V_{IN}$ down until output is turned OFF		3.16		V
$V_{IN(POWERUP)}$	Power-up voltage	Ramp $V_{IN}$ up until output is turned ON		3.45		V
<b>ENABLE INPUT (EN PIN)</b>						
$V_{IL}$	Logic input low level		0		0.8	V
$V_{IH}$	Logic input high level		2.5		40	V
<b>REGULATED OUTPUT VOLTAGE (VOUT PIN)</b>						
$V_{REF}$	Internal Reference Voltage	$I_{OUT} = 10$ mA to 300 mA, $V_{IN} = V_{OUT} + 1$ V to 16 V	-2%		2%	
$\Delta V_{LINE-REG}$	Line regulation	$V_{IN} = 6$ V to 28 V, $I_{OUT} = 10$ mA, $V_{OUT} = 7$ V			15	mV
		$[V_{IN} = 6$ V to 28 V, $I_{OUT} = 10$ mA, $V_{OUT} = 3.3$ V] <sup>(2)</sup>			20	
$\Delta V_{LOAD-REG}$	Load regulation	$I_{OUT} = 10$ mA to 300 mA, $V_{IN} = 14$ V, $V_{OUT} = 7$ V			25	mV
		$[I_{OUT} = 10$ mA to 300 mA, $V_{IN} = 14$ V, $V_{OUT} = 3.3$ V] <sup>(2)</sup>			35	

- (1)  $V_{IN}$  can go down to 4 V for 130 ms or less and remain functional. If  $V_{IN}$  is less than 7 V for longer than 130 ms, then some devices may turn off until the input voltage rises above 7 V.
- (2) Specified by design – not tested.

**Electrical Characteristics (continued)**
 $V_{IN} = 14\text{ V}$ ,  $T_J = -40^{\circ}\text{C}$  to  $150^{\circ}\text{C}$  (unless otherwise noted)

PARAMETER		TEST CONDITIONS	MIN	TYP	MAX	UNIT
$V_{\text{DROPOUT}}^{(3)}$	Dropout voltage ( $V_{\text{IN}} - V_{\text{OUT}}$ )	$I_{\text{OUT}} = 250\text{ mA}$			500	mV
		$I_{\text{OUT}} = 150\text{ mA}$			300	
$R_{\text{SW}}^{(2)}$	Switch resistance	$V_{\text{IN}}$ to $V_{\text{OUT}}$ resistance			2	$\Omega$
$I_{\text{OUT}}$	Output current	$V_{\text{OUT}}$ in regulation	0		300	mA
$I_{\text{CL}}$	Output current limit	$V_{\text{OUT}} = 0\text{ V}$ ( $V_{\text{OUT}}$ pin is shorted to ground)	350		1000	mA
$\text{PSRR}^{(2)}$	Power supply ripple rejection	$V_{\text{IN-RIPPLE}} = 0.5\text{ Vpp}$ , $I_{\text{OUT}} = 300\text{ mA}$ , frequency = 100 Hz, $V_{\text{OUT}} = 5\text{ V}$ and $V_{\text{OUT}} = 3.3\text{ V}$		60		dB
		$V_{\text{IN-RIPPLE}} = 0.5\text{ Vpp}$ , $I_{\text{OUT}} = 300\text{ mA}$ , frequency = 150 kHz, $V_{\text{OUT}} = 5\text{ V}$ and $V_{\text{OUT}} = 3.3\text{ V}$		30		
<b>OPERATING TEMPERATURE RANGE</b>						
$T_J$	Operating junction temperature		-40		150	$^{\circ}\text{C}$
$T_{\text{SHUTDOWN}}$	Thermal shutdown trip point			165		$^{\circ}\text{C}$
$T_{\text{HYST}}$	Thermal shutdown hysteresis			10		$^{\circ}\text{C}$

(3) This test is done with  $V_{\text{OUT}}$  is in regulation and  $V_{\text{IN}} - V_{\text{OUT}}$  parameter is measured when  $V_{\text{OUT}}$  (programmed output voltage, for example, 5 V or 3.3 V) drops by 100 mV at specified loads.

### 6.6 Typical Characteristics

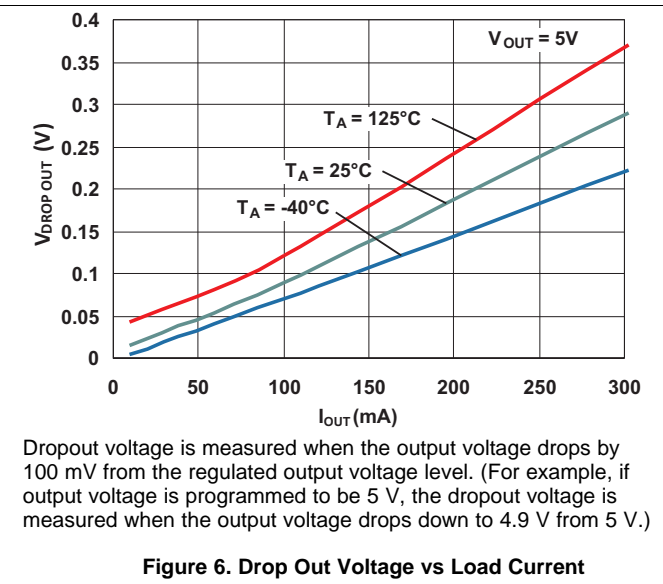
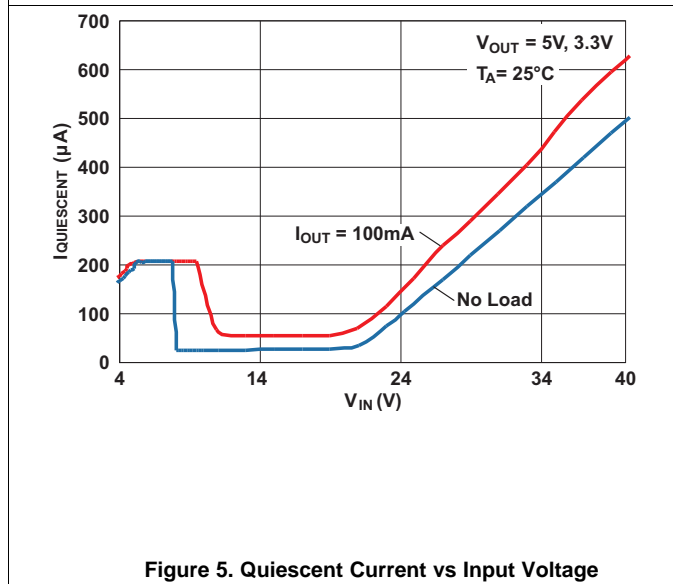
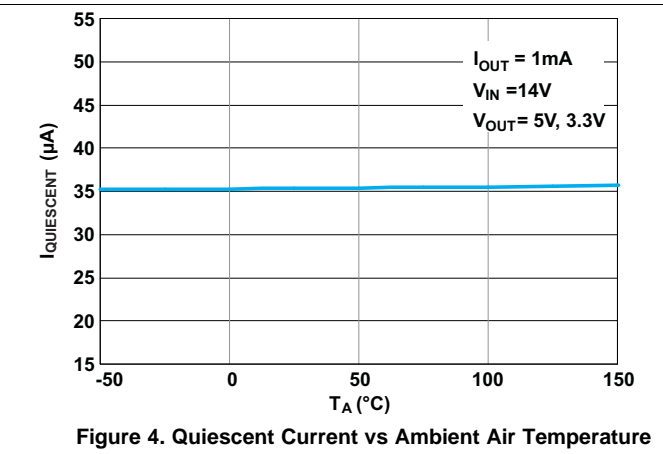
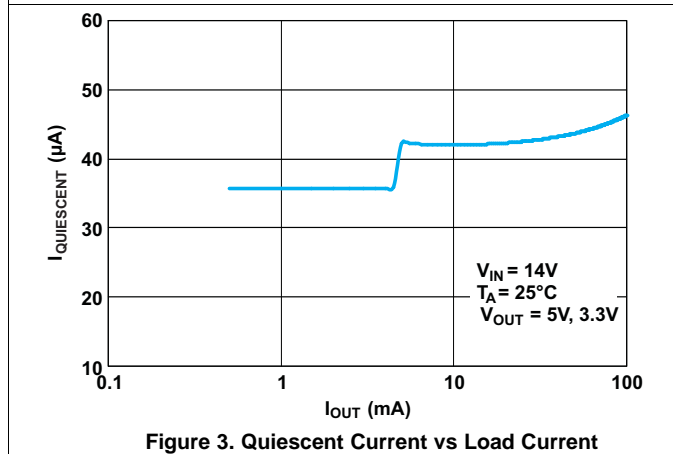
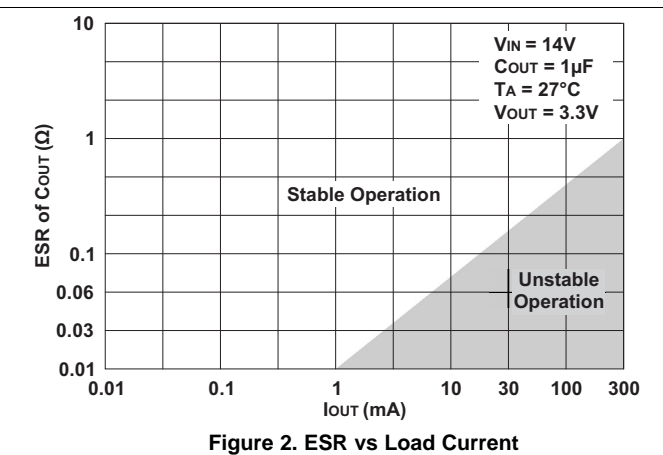
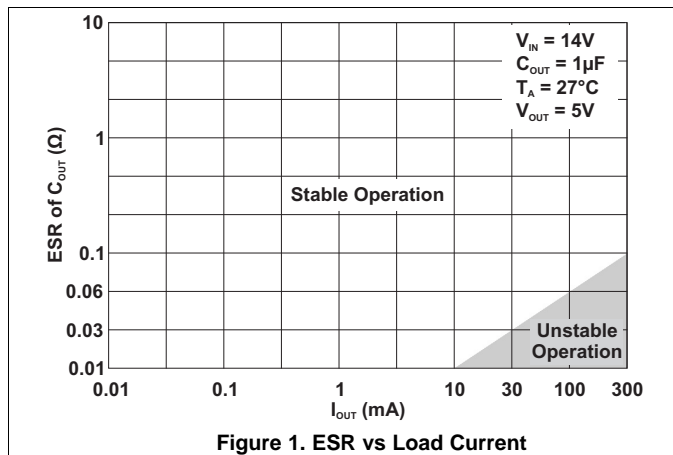

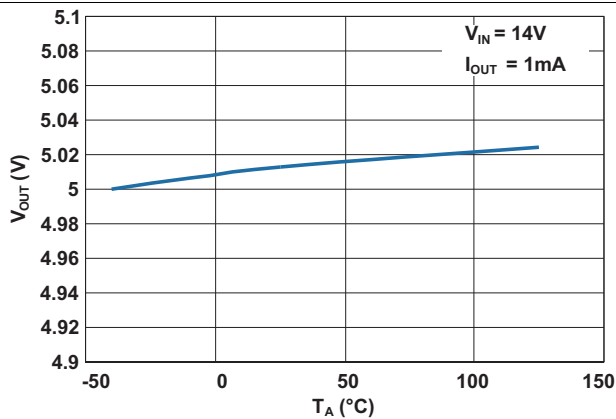
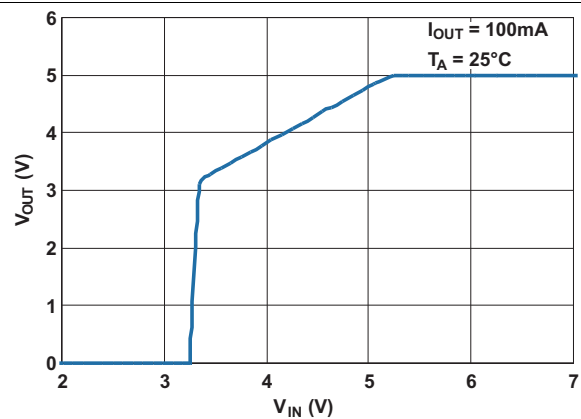
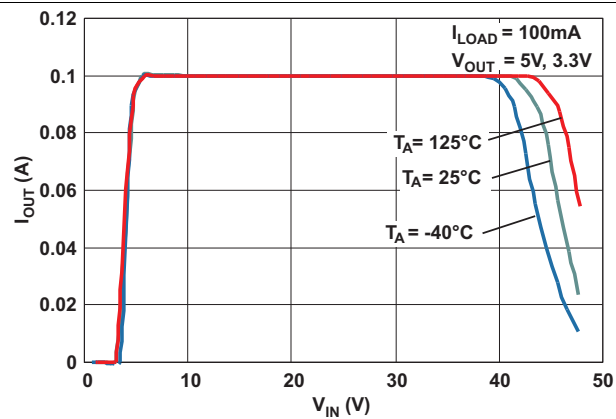
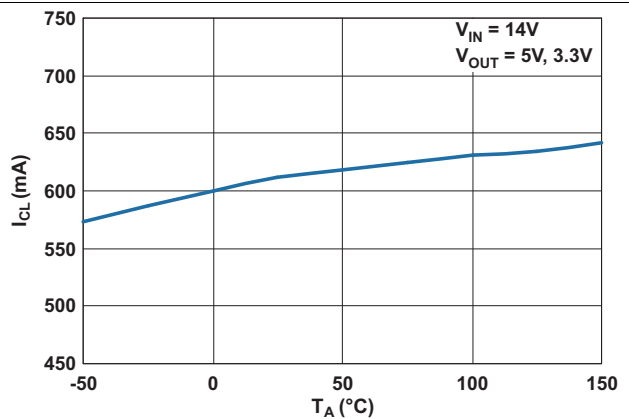
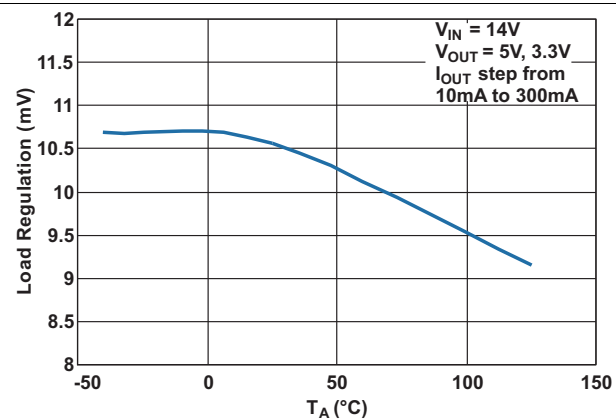
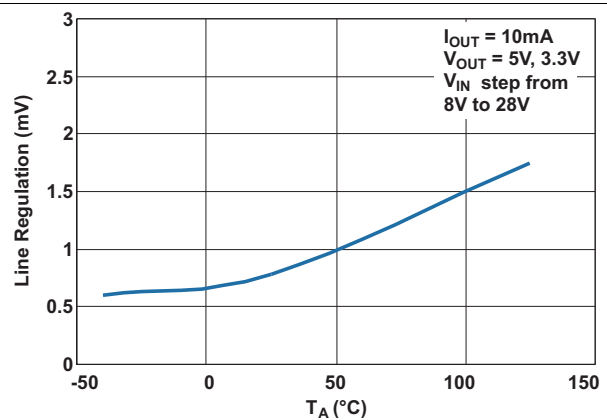
**Typical Characteristics (continued)**

**Figure 7. Output Voltage vs Ambient Air Temperature**  
 ( $V_{OUT}$  Programmed to 5 V)

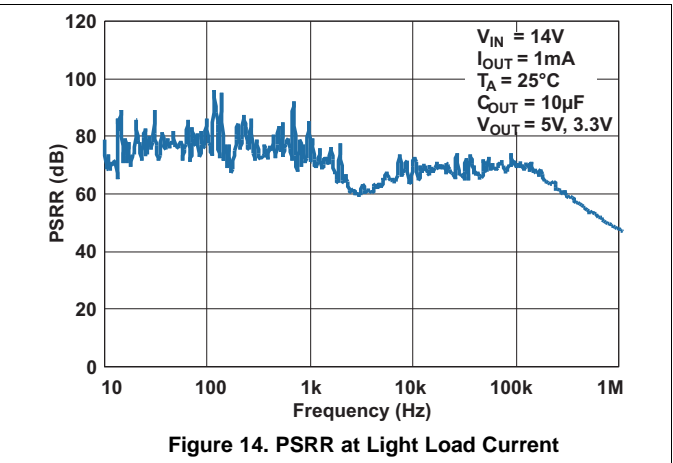
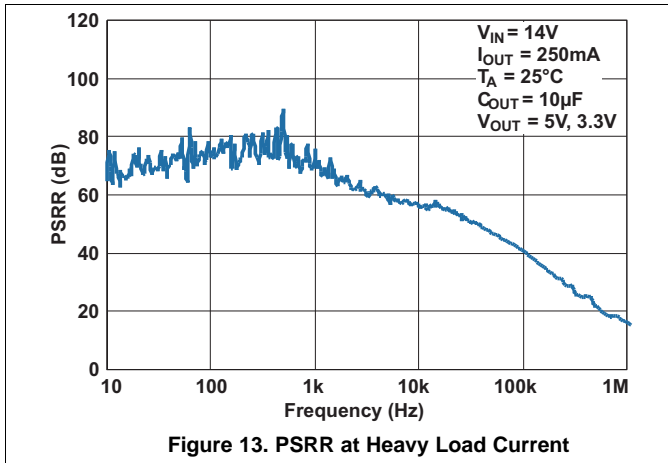
**Figure 8. Output Voltage vs Input Voltage**  
 ( $V_{OUT}$  Programmed to 5 V)

**Figure 9. Output Current vs Input Voltage**

**Figure 10. Output Current Limit vs Ambient Air Temperature**

**Figure 11. Load Regulation vs Ambient Air Temperature**

**Figure 12. Line Regulation vs Ambient Air Temperature**

Typical Characteristics (continued)



## 7 Detailed Description

### 7.1 Overview

The TPS7A6201-Q1 device is a monolithic, low-dropout linear voltage regulator with programmable output voltage and integrated fault protection. This voltage regulator is designed for low power consumption and quiescent current less than 25  $\mu\text{A}$  in light-load applications.

This device is available in the 5-pin package option TO-263 (D2PAK/TO-263).

The following section describes the features of TPS7A6201-Q1 voltage regulator in detail.

### 7.2 Functional Block Diagram

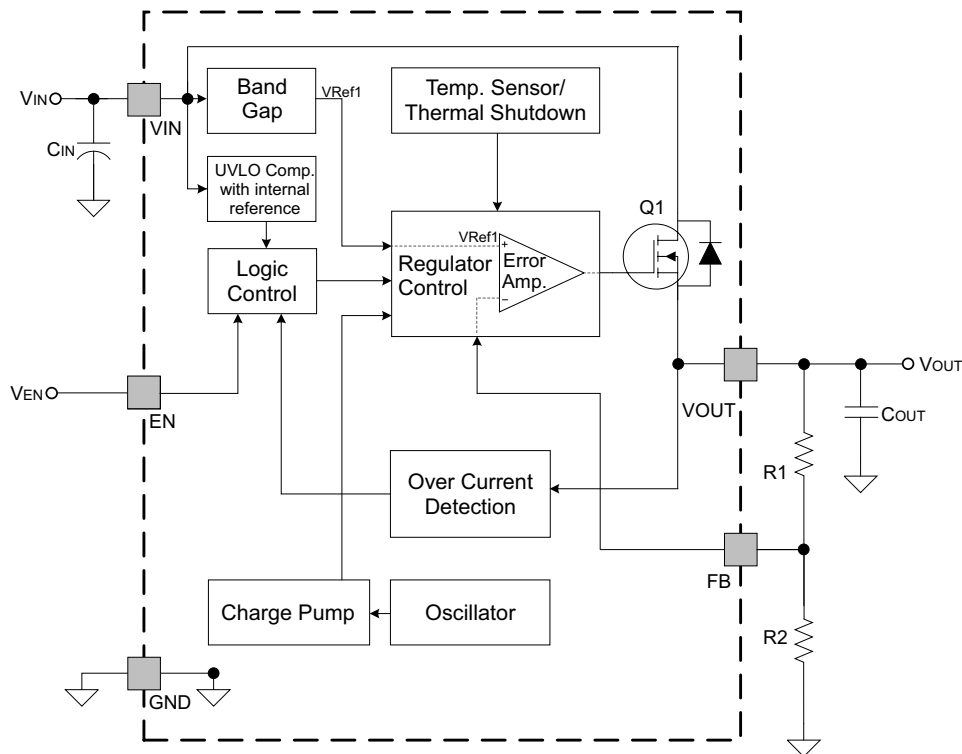

## 7.3 Feature Description

### 7.3.1 Power Up

During power up, the regulator incorporates a protection scheme to limit the current through pass element and output capacitor. When the input voltage exceeds a certain threshold ( $V_{IN(PowerUp)}$ ) level, the output voltage begins to ramp up as shown in [Figure 15](#).

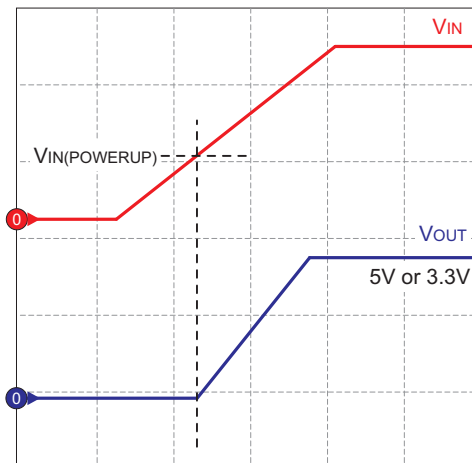

**Figure 15. Power-Up Operation**

### 7.3.2 Adjustable Output Voltage

The regulated output voltage ( $V_{OUT}$ ) can be programmed by connecting external resistors to FB pin. Calculate the feedback resistor values using [Equation 1](#).

$$V_{OUT} = V_{REF} \left[ 1 + \frac{R1}{R2} \right]$$

where

- $V_{OUT}$  = desired output voltage
  - $V_{REF}$  = reference voltage ( $V_{REF} = 1.23$  V typically)
  - $R1, R2$  = feedback resistors (see the [Functional Block Diagram](#))
- (1)

The overall tolerance of the regulated output voltage depends on the tolerance of internal reference voltage and external feedback resistors, and is given by [Equation 2](#).

$$tol_{V_{OUT}} = tol_{V_{REF}} + \left[ \frac{R1}{R1 + R2} \right] [tol_{R1} + tol_{R2}]$$

where

- $tol_{V_{OUT}}$  = tolerance of output voltage
  - $tol_{V_{REF}}$  = tolerance of internal reference voltage ( $tol_{V_{REF}} = \pm 1.5\%$  typically)
  - $tol_{R1}, tol_{R2}$  = tolerance of feedback resistors  $R1, R2$
- (2)

For a tighter tolerance on  $V_{OUT}$ , select lower-value feedback resistors. TI recommends selecting feedback resistors such that the sum of  $R1$  and  $R2$  is between 20 k $\Omega$  and 200 k $\Omega$ .

### 7.3.3 Enable Input

This device has a high-voltage-tolerant EN pin that can be used to enable and disable a device from an external microcontroller or a digital control circuit. A high input to this pin activates the device and turns the regulator on. This input can also be connected to  $V_{IN}$  terminal for self bias applications. An internal pulldown resistor is connected to this pin; therefore, if this pin is left unconnected, the device stays disabled.

## Feature Description (continued)

### 7.3.4 Charge Pump Operation

This device has an internal charge pump which turns on or off depending on the input voltage and the output current. The charge pump switching circuitry shall not cause conducted emissions to exceed required thresholds on the input voltage line. For a given output current, the charge pump stays on at lower input voltages and turns off at higher input voltages. The charge pump switching thresholds are hysteretic. Figure 16 and Figure 17 shows typical switching thresholds for the charge pump at light ( $I_{OUT} < \sim 2$  mA) and heavy ( $I_{OUT} > \sim 2$  mA) loads respectively.

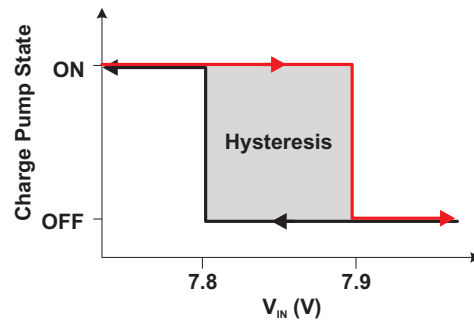

Figure 16. Charge Pump Operation at Light Loads

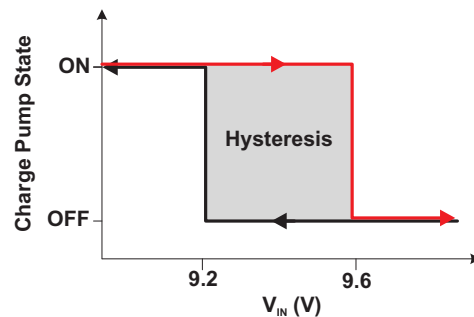

Figure 17. Charge Pump Operation at Heavy Loads

### 7.3.5 Undervoltage Shutdown

This device has an integrated undervoltage lockout (UVLO) circuit to shut down the output if the input voltage ( $V_{IN}$ ) falls below an internally fixed UVLO threshold level ( $V_{IN-UVLO}$ ); see Figure 18. This ensures that the regulator is not latched into an unknown state during low input voltage conditions. The regulator normally powers up when the input voltage exceeds the  $V_{IN(POWERUP)}$  threshold.

### 7.3.6 Low Voltage Tracking

At low-input voltages, the regulator drops out of regulation, and the output voltage tracks input minus a voltage based on the load current and switch resistance (see Figure 18). This allows for a smaller input capacitor and can possibly eliminate the need of using a boost converter during cold crank conditions.

## Feature Description (continued)

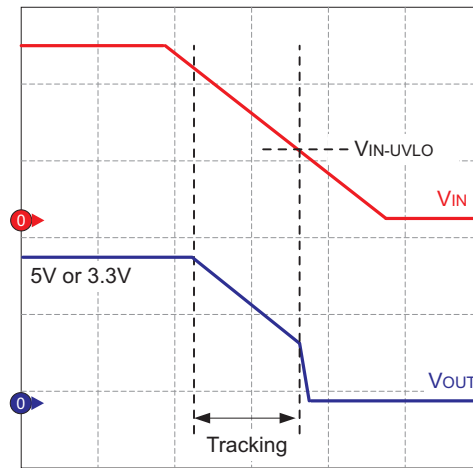

Figure 18. Low Voltage Tracking Operation

### 7.3.7 Integrated Fault Protection

The device features integrated fault protection, making it ideal for use in automotive applications. To keep the device in safe area of operation during certain fault conditions, internal current-limit protection and current-limit foldback are used to limit the maximum output current. This protects the device from excessive power dissipation. For example, during a short-circuit condition on the output, current through the pass element is limited to  $I_{CL}$  to protect the device from excessive power dissipation.

### 7.3.8 Thermal Shutdown

The device incorporates a thermal shutdown (TSD) circuit as protection from overheating. For continuous normal operation, the junction temperature must not exceed the TSD trip point. If the junction temperature exceeds the TSD trip point, the output is turned off. When the junction temperature falls below TSD trip point, the output is turned on again, as shown in Figure 19.

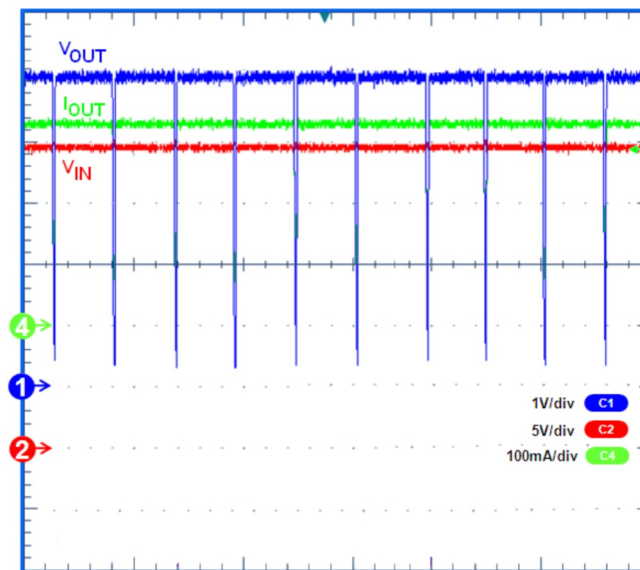

Figure 19. Thermal Cycling Waveform for TPS7A6201-Q1 ( $V_{IN} = 24\text{ V}$ ,  $I_{OUT} = 300\text{ mA}$ ,  $V_{OUT} = 5\text{ V}$ )

## 7.4 Device Functional Modes

### 7.4.1 Low Power Mode

At light loads and high-input voltages ( $V_{IN}$  > approximately 8 V such that charge pump is off) the device operates in low power mode, and the quiescent current consumption is reduced to 25  $\mu$ A (typical) as shown in [Table 1](#).

**Table 1. Typical Quiescent Current Consumption**

$I_{OUT}$	CHARGE PUMP ON	CHARGE PUMP OFF
$I_{OUT}$ < approximately 2 mA (Light load)	250 $\mu$ A	25 $\mu$ A (Low Power Mode)
$I_{OUT}$ > approximately 2 mA (Heavy load)	280 $\mu$ A	70 $\mu$ A

## 8 Application and Implementation

### NOTE

Information in the following applications sections is not part of the TI component specification, and TI does not warrant its accuracy or completeness. TI's customers are responsible for determining suitability of components for their purposes. Customers should validate and test their design implementation to confirm system functionality.

### 8.1 Application Information

The TPS7A6201-Q1 is a low-dropout linear voltage regulator designed for low power consumption and quiescent current less than 25  $\mu$ A in light-load applications.

## 8.2 Typical Application

Figure 20 shows the typical application circuit for the TPS7A6201-Q1 device. Depending upon an end application, different values of external components may be used. To program the output voltage, feedback resistors (R1 and R2) must be carefully selected. Using small resistors results in higher current consumption, whereas, using very large resistors impacts the sensitivity of the regulator. Therefore, TI recommends selecting feedback resistors such that the sum of R1 and R2 is between 20 kΩ and 200 kΩ. Also, the overall tolerance of the regulated output voltage depends on the tolerance of the internal reference voltage and external feedback resistors.

A larger output capacitor may be required during fast load steps to prevent output from temporarily dropping down. TI recommends a low-ESR ceramic capacitor with a dielectric of type X5R or X7R. Additionally, a bypass capacitor can be connected at the output to decouple high-frequency noise as per the end application.

**Example:** If the desired regulated output voltage is 5 V, upon selecting R2, R1 can be calculated using Equation 1 (and vice versa). Knowing  $V_{REF} = 1.23\text{ V}$  (typical),  $V_{OUT} = 5\text{ V}$ , and selecting  $R2 = 20\text{ k}\Omega$ , R1 is calculated to be 61.3 kΩ.

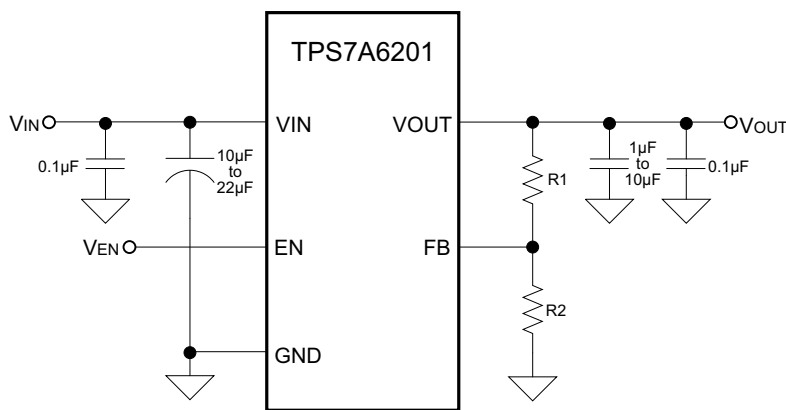

**Figure 20. Typical Application Schematic for TPS7A6201-Q1**

### 8.2.1 Design Requirements

Table 2 lists the design parameters for this example.

**Table 2. Design Parameters**

PARAMETER	EXAMPLE VALUE
Input voltage range	7 V to 40 V
Output voltage	5 V
Output current rating	200 mA
Output capacitor range	10 µF to 47 µF
Output capacitor ESR range	10 mΩ to 10 Ω

### 8.2.2 Detailed Design Procedure

To begin the design process, determine the following:

- Input voltage range
- Output voltage
- Output current rating
- Input capacitor
- Output capacitor

#### 8.2.2.1 Input Capacitor

The device requires an input bypass capacitor, the value of which depends on the application. The typical recommended value for the bypass capacitor is 10 µF. The voltage rating must be greater than the maximum input voltage.

### 8.2.2.2 Output Capacitor

The device requires an output capacitor to stabilize the output voltage. TI recommends selecting a capacitor between 10  $\mu\text{F}$  and 47  $\mu\text{F}$  with ESR range from 10  $\text{m}\Omega$  to 10  $\Omega$ .

### 8.2.2.3 Feedback Resistor

The regulated output voltage (VOUT) can be programmed by connecting external resistors to FB pin. Calculate the feedback resistor values using [Equation 1](#) ( $R1 = 61.3\text{K}\ \Omega$ ,  $R2 = 20\text{K}\ \Omega$ ).

## 8.2.3 Application Curve

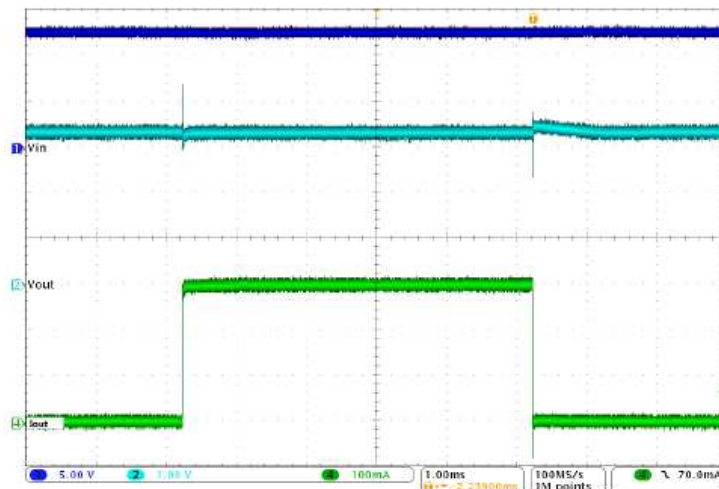

Figure 21. Load Transient Waveform

## 9 Power Supply Recommendations

Design of the device is for operation from an input voltage supply with a range from 7 V to 40 V. This input supply must be well regulated. If the input supply is located more than a few inches from the device, TI recommends adding an electrolytic capacitor with a value of 22  $\mu\text{F}$  and a ceramic bypass capacitor at the input.

## 10 Layout

### 10.1 Layout Guidelines

For the LDO power supply, especially these high voltage and large current ones, layout is an important step. If layout is not carefully designed, the regulator could not deliver enough output current because of the thermal limitation. To improve the thermal performance of the device, and maximize the current output at high ambient temperature, TI recommends spreading the thermal pad as large as possible and place enough thermal vias on the thermal pad. [Figure 25](#) provides an example layout.

#### 10.1.1 Power Dissipation and Thermal Considerations

Calculate the power dissipated in the device using [Equation 3](#).

$$P_D = I_{OUT} \times (V_{IN} - V_{OUT}) + I_{QUIESCENT} \times V_{IN}$$

where

- $P_D$  = continuous power dissipation
- $I_{OUT}$  = output current
- $V_{IN}$  = input voltage
- $V_{OUT}$  = output voltage
- $I_{QUIESCENT}$  = quiescent current

(3)

As  $I_{QUIESCENT} \ll I_{OUT}$ , therefore, the term  $I_{QUIESCENT} \times V_{IN}$  in [Equation 3](#) can be ignored.

For device under operation at a given ambient air temperature ( $T_A$ ), calculate the junction temperature ( $T_J$ ) [Equation 4](#).

$$T_J = T_A + (R_{\theta JA} \times P_D)$$

where

- $R_{\theta JA}$  = junction to ambient air thermal impedance

(4)

Calculate the rise in junction temperature due to power dissipation using [Equation 5](#).

$$\Delta T = T_J - T_A = (R_{\theta JA} \times P_D)$$

(5)

For a given maximum junction temperature ( $T_{J-Max}$ ), calculate the maximum ambient air temperature ( $T_{A-Max}$ ) at which the device can operate using [Equation 6](#).

$$T_{A-Max} = T_{J-Max} - (R_{\theta JA} \times P_D)$$

(6)

#### Example

If  $I_{OUT} = 100$  mA,  $V_{OUT} = 5$  V,  $V_{IN} = 14$  V,  $I_{QUIESCENT} = 250$   $\mu$ A, and  $R_{\theta JA} = 30^\circ\text{C/W}$ , the continuous power dissipated in the device is 0.9 W. The rise in junction temperature due to power dissipation is 27°C. For a maximum junction temperature of 150°C, maximum ambient air temperature at which the device can operate is 123°C.

For adequate heat dissipation, TI recommends soldering the thermal pad (exposed heat sink) to thermal land pad on the PCB. Doing this provides a heat conduction path from die to the PCB and reduces overall package thermal resistance. [Figure 22](#) illustrates the power derating curves for the TPS7A6201-Q1 device in the KTT (TO-263) package..

**Layout Guidelines (continued)**

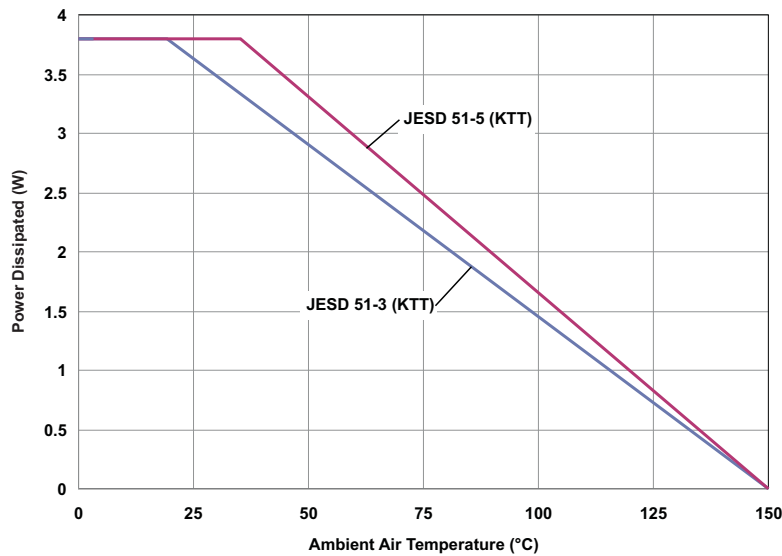

**Figure 22. Power Derating Curves**

For optimum thermal performance, TI recommends using a high-K PCB with thermal vias between ground plane and solder pad or thermal land pad. This is shown in [Figure 23](#) (a) and (b). Furthermore, heat spreading capabilities of a PCB can be considerably improved by using a thicker ground plane and a thermal land pad with a larger surface area.

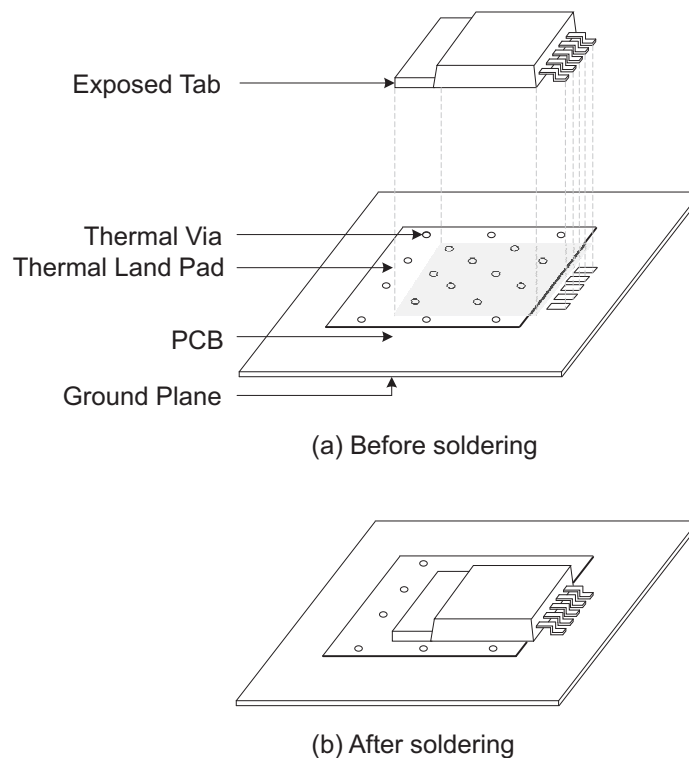

**Figure 23. Using Multilayer PCB and Thermal Vias for Adequate Heat Dissipation**

### Layout Guidelines (continued)

Keeping other factors constant, surface area of the thermal land pad contributes to heat dissipation only to a certain extent. Figure 24 shows a variation of  $R_{\theta JA}$  with surface area of the thermal land pad (soldered to the exposed pad) for KTT package.

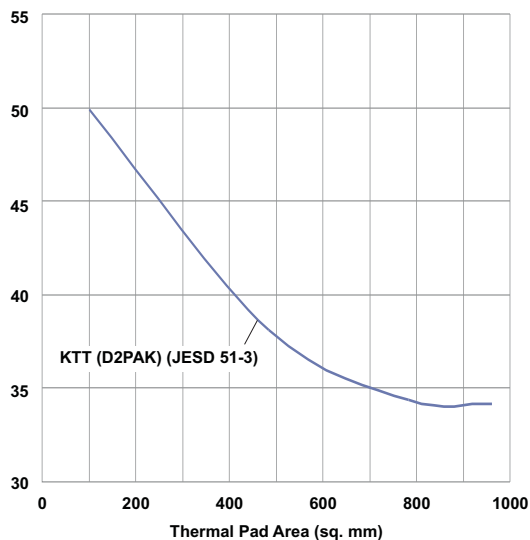

Figure 24.  $R_{\theta JA}$  vs Thermal Pad Area

### 10.2 Layout Example

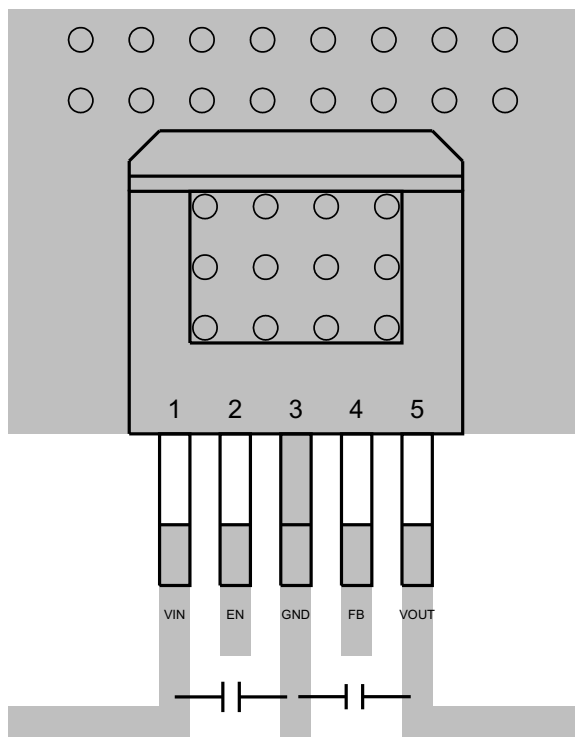

Figure 25. Layout Recommendation

## 11 Device and Documentation Support

### 11.1 Receiving Notification of Documentation Updates

To receive notification of documentation updates, navigate to the device product folder on ti.com. In the upper right corner, click on *Alert me* to register and receive a weekly digest of any product information that has changed. For change details, review the revision history included in any revised document.

### 11.2 Community Resources

TI E2E™ [support forums](#) are an engineer's go-to source for fast, verified answers and design help — straight from the experts. Search existing answers or ask your own question to get the quick design help you need.

Linked content is provided "AS IS" by the respective contributors. They do not constitute TI specifications and do not necessarily reflect TI's views; see TI's [Terms of Use](#).

### 11.3 Trademarks

E2E is a trademark of Texas Instruments.  
All other trademarks are the property of their respective owners.

### 11.4 Electrostatic Discharge Caution



These devices have limited built-in ESD protection. The leads should be shorted together or the device placed in conductive foam during storage or handling to prevent electrostatic damage to the MOS gates.

### 11.5 Glossary

[SLYZ022](#) — *TI Glossary*.

This glossary lists and explains terms, acronyms, and definitions.

## 12 Mechanical, Packaging, and Orderable Information

The following pages include mechanical, packaging, and orderable information. This information is the most current data available for the designated devices. This data is subject to change without notice and revision of this document. For browser-based versions of this data sheet, refer to the left-hand navigation.

**PACKAGING INFORMATION**

Orderable Device	Status (1)	Package Type	Package Drawing	Pins	Package Qty	Eco Plan (2)	Lead finish/ Ball material (6)	MSL Peak Temp (3)	Op Temp (°C)	Device Marking (4/5)	Samples
TPS7A6201QKTTTRQ1	ACTIVE	DDPAK/ TO-263	KTT	5	500	RoHS & Green	SN	Level-3-245C-168 HR	-40 to 125	7A6201Q1	<b>Samples</b>

(1) The marketing status values are defined as follows:

**ACTIVE:** Product device recommended for new designs.

**LIFEBUY:** TI has announced that the device will be discontinued, and a lifetime-buy period is in effect.

**NRND:** Not recommended for new designs. Device is in production to support existing customers, but TI does not recommend using this part in a new design.

**PREVIEW:** Device has been announced but is not in production. Samples may or may not be available.

**OBSOLETE:** TI has discontinued the production of the device.

(2) **RoHS:** TI defines "RoHS" to mean semiconductor products that are compliant with the current EU RoHS requirements for all 10 RoHS substances, including the requirement that RoHS substance do not exceed 0.1% by weight in homogeneous materials. Where designed to be soldered at high temperatures, "RoHS" products are suitable for use in specified lead-free processes. TI may reference these types of products as "Pb-Free".

**RoHS Exempt:** TI defines "RoHS Exempt" to mean products that contain lead but are compliant with EU RoHS pursuant to a specific EU RoHS exemption.

**Green:** TI defines "Green" to mean the content of Chlorine (Cl) and Bromine (Br) based flame retardants meet JS709B low halogen requirements of <=100ppm threshold. Antimony trioxide based flame retardants must also meet the <=1000ppm threshold requirement.

(3) MSL, Peak Temp. - The Moisture Sensitivity Level rating according to the JEDEC industry standard classifications, and peak solder temperature.

(4) There may be additional marking, which relates to the logo, the lot trace code information, or the environmental category on the device.

(5) Multiple Device Markings will be inside parentheses. Only one Device Marking contained in parentheses and separated by a "~" will appear on a device. If a line is indented then it is a continuation of the previous line and the two combined represent the entire Device Marking for that device.

(6) Lead finish/Ball material - Orderable Devices may have multiple material finish options. Finish options are separated by a vertical ruled line. Lead finish/Ball material values may wrap to two lines if the finish value exceeds the maximum column width.

**Important Information and Disclaimer:**The information provided on this page represents TI's knowledge and belief as of the date that it is provided. TI bases its knowledge and belief on information provided by third parties, and makes no representation or warranty as to the accuracy of such information. Efforts are underway to better integrate information from third parties. TI has taken and continues to take reasonable steps to provide representative and accurate information but may not have conducted destructive testing or chemical analysis on incoming materials and chemicals. TI and TI suppliers consider certain information to be proprietary, and thus CAS numbers and other limited information may not be available for release.

In no event shall TI's liability arising out of such information exceed the total purchase price of the TI part(s) at issue in this document sold by TI to Customer on an annual basis.

## TAPE AND REEL INFORMATION



### QUADRANT ASSIGNMENTS FOR PIN 1 ORIENTATION IN TAPE

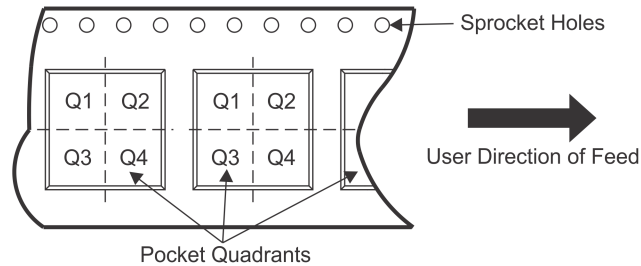

\*All dimensions are nominal

Device	Package Type	Package Drawing	Pins	SPQ	Reel Diameter (mm)	Reel Width W1 (mm)	A0 (mm)	B0 (mm)	K0 (mm)	P1 (mm)	W (mm)	Pin1 Quadrant
TPS7A6201QKTTRQ1	DDPAK/ TO-263	KTT	5	500	330.0	24.4	10.6	15.8	4.9	16.0	24.0	Q2

**TAPE AND REEL BOX DIMENSIONS**

\*All dimensions are nominal

Device	Package Type	Package Drawing	Pins	SPQ	Length (mm)	Width (mm)	Height (mm)
TPS7A6201QKTTRQ1	DDPAK/TO-263	KTT	5	500	340.0	340.0	38.0



KTT (R-PSFM-G5)

PLASTIC FLANGE-MOUNT PACKAGE



- NOTES:
- A. All linear dimensions are in millimeters.
  - B. This drawing is subject to change without notice.
  - C. Body dimensions do not include mold flash or protrusion. Mold flash or protrusion not to exceed 0.005 (0,13) per side.
- $\triangle$  Falls within JEDEC TO-263 variation BA, except minimum lead thickness, maximum seating height, and minimum body length.

KTT (R-PSFM-G5)

PLASTIC FLANGE-MOUNT PACKAGE

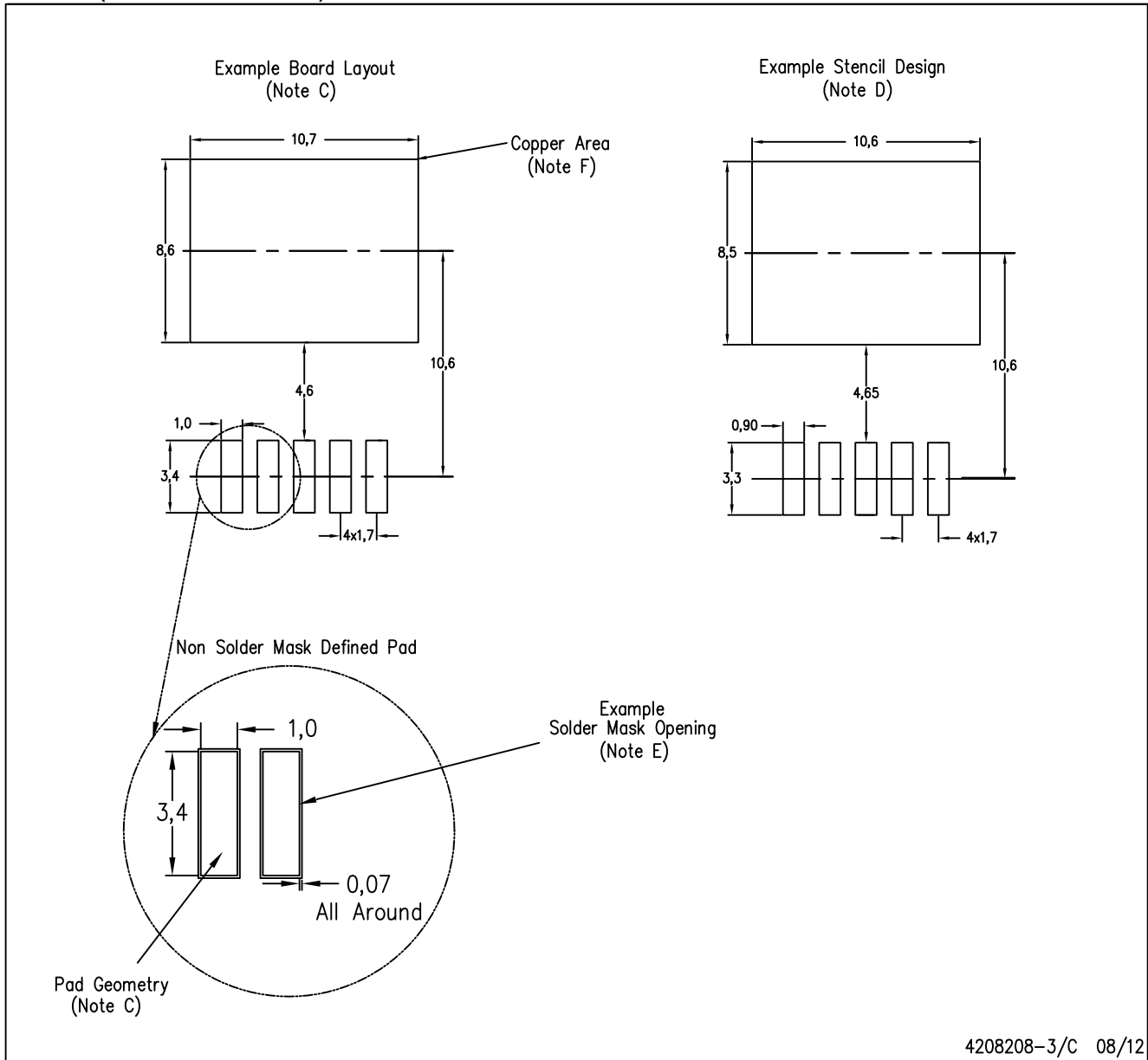

4208208-3/C 08/12

- NOTES:
- All linear dimensions are in millimeters.
  - This drawing is subject to change without notice.
  - Publication IPC-SM-782 is recommended for alternate designs.
  - Laser cutting apertures with trapezoidal walls and also rounding corners will offer better paste release. Customers should contact their board assembly site for stencil design recommendations. Refer to IPC-7525.
  - Customers should contact their board fabrication site for solder mask tolerances between and around signal pads.
  - This package is designed to be soldered to a thermal pad on the board. Refer to the Product Datasheet for specific thermal information, via requirements, and recommended thermal pad size. For thermal pad sizes larger than shown a solder mask defined pad is recommended in order to maintain the solderable pad geometry while increasing copper area.

## IMPORTANT NOTICE AND DISCLAIMER

TI PROVIDES TECHNICAL AND RELIABILITY DATA (INCLUDING DATASHEETS), DESIGN RESOURCES (INCLUDING REFERENCE DESIGNS), APPLICATION OR OTHER DESIGN ADVICE, WEB TOOLS, SAFETY INFORMATION, AND OTHER RESOURCES "AS IS" AND WITH ALL FAULTS, AND DISCLAIMS ALL WARRANTIES, EXPRESS AND IMPLIED, INCLUDING WITHOUT LIMITATION ANY IMPLIED WARRANTIES OF MERCHANTABILITY, FITNESS FOR A PARTICULAR PURPOSE OR NON-INFRINGEMENT OF THIRD PARTY INTELLECTUAL PROPERTY RIGHTS.

These resources are intended for skilled developers designing with TI products. You are solely responsible for (1) selecting the appropriate TI products for your application, (2) designing, validating and testing your application, and (3) ensuring your application meets applicable standards, and any other safety, security, or other requirements. These resources are subject to change without notice. TI grants you permission to use these resources only for development of an application that uses the TI products described in the resource. Other reproduction and display of these resources is prohibited. No license is granted to any other TI intellectual property right or to any third party intellectual property right. TI disclaims responsibility for, and you will fully indemnify TI and its representatives against, any claims, damages, costs, losses, and liabilities arising out of your use of these resources.

TI's products are provided subject to TI's Terms of Sale ([www.ti.com/legal/termsofsale.html](http://www.ti.com/legal/termsofsale.html)) or other applicable terms available either on [ti.com](http://ti.com) or provided in conjunction with such TI products. TI's provision of these resources does not expand or otherwise alter TI's applicable warranties or warranty disclaimers for TI products.

Mailing Address: Texas Instruments, Post Office Box 655303, Dallas, Texas 75265  
Copyright © 2020, Texas Instruments Incorporated

## Looking for pricing, stock, or lifecycle information?

Click below to explore more details on WIN SOURCE:

 [View TPS7A6201QKTTRQ1 on WIN SOURCE](#)

 [Texas Instruments](#) Information

## Optimize Your Supply Chain with WIN SOURCE Solutions

-  Global Sourcing Solution
-  Obsolete Management
-  Cost Control Management
-  Shortage Management
-  Alternative Solution
-  Excess Inventory Management