



**THE DATASHEET OF  
AZ1085CS2-ADJTRE1**



## Description

The AZ1085C is a series of low dropout positive voltage regulators with a maximum dropout of 1.5V at 3A of load current.

The series features on-chip thermal shutdown. It also includes a bandgap reference and a current limiting circuit.

The AZ1085C is available in 1.5V, 1.8V, 2.5V, 3.3V, 5.0V and adjustable versions. The fixed versions integrate the adjust resistors. The adjustable version can set the output voltage with two external resistors.

The AZ1085C series is available in standard packages of TO263, TO263-2, TO252-2 (3), TO252-2 (4) and TO252-2 (5).

## Applications

- High Efficiency Linear Regulators
- Battery Charger
- Post Regulation for Switching Supplies
- Microprocessor Supply
- Mother Board Power Supplies
- DVD-Video Player
- Telecom Equipment
- Set Top Boxes and Web Boxes Modules' Supply

## Features

- Low Dropout Voltage: Typical 1.3V at 3A
- Current Limiting and Thermal Protection
- Output Current: 3A
- Current Limit: 4.5A
- Operating Junction Temperature: 0 to +125°C
- Compatible with Low ESR Ceramic Capacitor
- Line Regulation: 0.015% (Typ)
- Load Regulation: 0.1% (Typ)
- Lead-Free Packages: TO263, TO263-2
  - **Totally Lead-Free; RoHS Compliant (Notes 1 & 2)**
- Lead-Free Packages, Available in "Green" Molding Compound: TO263, TO263-2, TO252-2 (3), TO252-2 (4), TO252-2 (5)
  - **Totally Lead-Free & Fully RoHS Compliant (Notes 1 & 2)**
  - **Halogen and Antimony Free. "Green" Device (Note 3)**

- Notes:
1. No purposely added lead. Fully EU Directive 2002/95/EC (RoHS), 2011/65/EU (RoHS 2) & 2015/863/EU (RoHS 3) compliant.
  2. See <https://www.diodes.com/quality/lead-free/> for more information about Diodes Incorporated's definitions of Halogen- and Antimony-free, "Green" and Lead-free.
  3. Halogen- and Antimony-free "Green" products are defined as those which contain <900ppm bromine, <900ppm chlorine (<1500ppm total Br + Cl) and <1000ppm antimony compounds.

## Pin Assignments

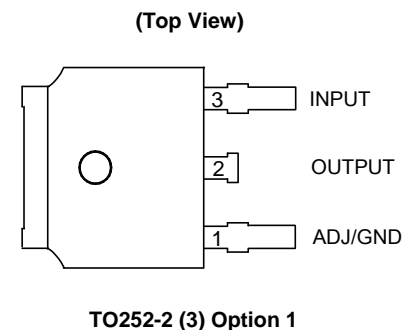
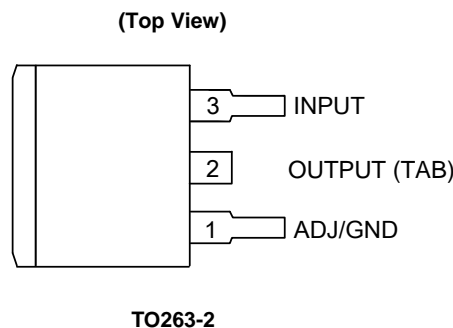
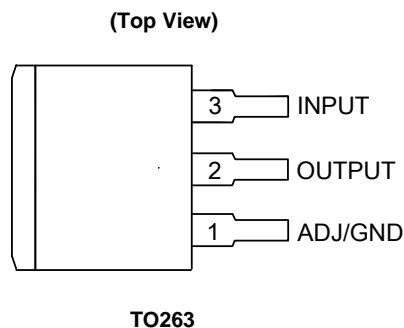

**Pin Assignments (Cont.)**

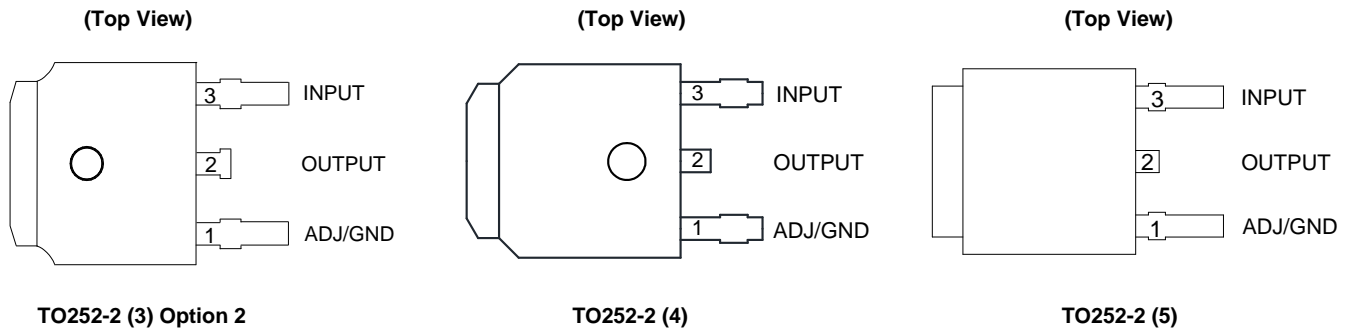

**Typical Applications Circuit**

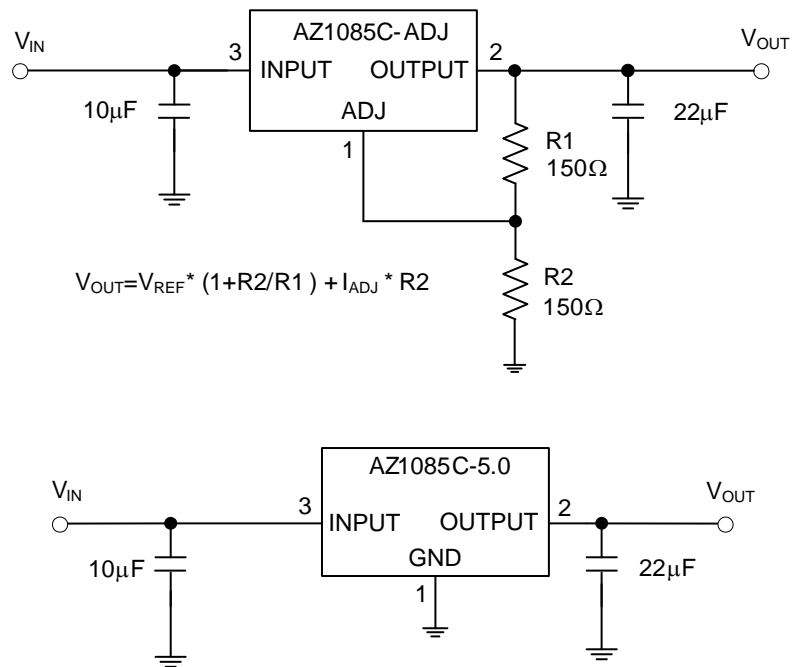

**Functional Block Diagram**

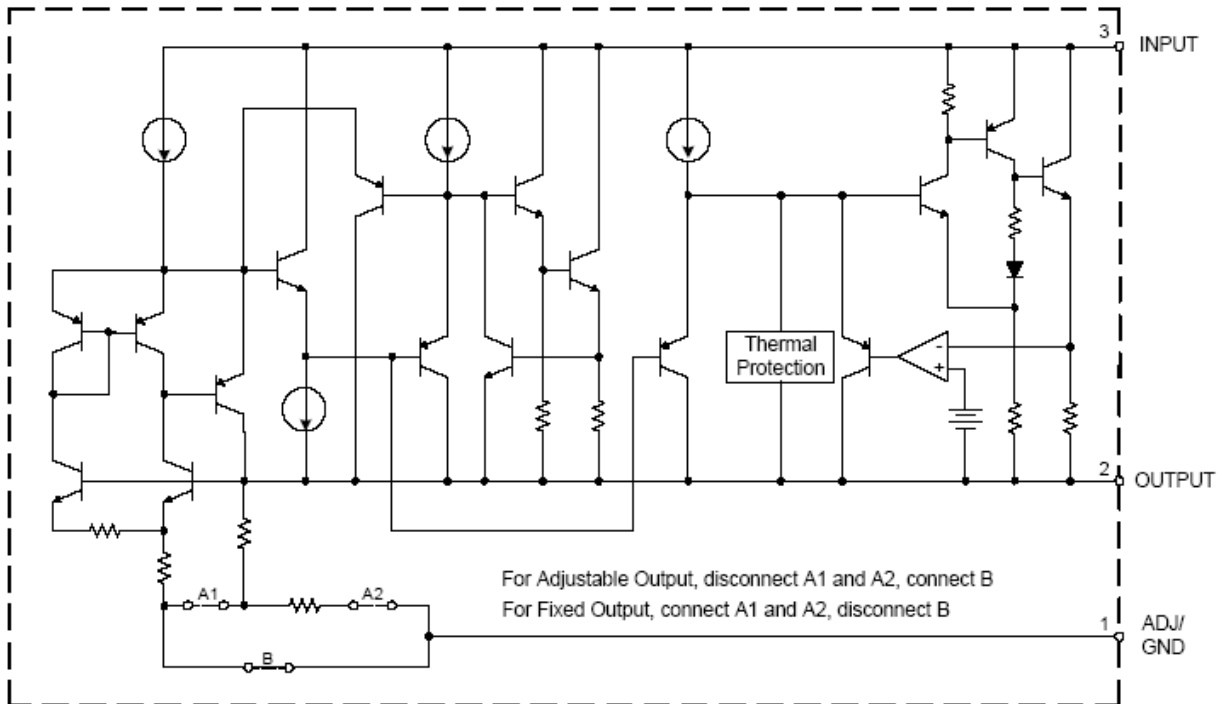

**Absolute Maximum Ratings** (Note 4)

Symbol	Parameter	Rating		Unit
$V_{IN}$	Input Voltage	13.2		V
$T_J$	Operating Junction Temperature	+150		°C
$T_{STG}$	Storage Temperature Range	-65 to +150		°C
$T_{LEAD}$	Lead Temperature (Soldering, 10sec.)	+260		°C
$\theta_{JA}$	Thermal Resistance (Note 5)	TO263	75	°C/W
		TO263-2	75	
		TO252-2 (3)/TO252-2 (4)/ TO252-2 (5)	100	
ESD	ESD (Human Body Model)	2000		V

- Notes:
- Stresses greater than those listed under "Absolute Maximum Ratings" may cause permanent damage to the device. These are stress ratings only, and functional operation of the device at these or any other conditions beyond those indicated under "Recommended Operating Conditions" is not implied. Exposure to "Absolute Maximum Ratings" for extended periods may affect device reliability.
  - Absolute maximum ratings indicate limits beyond which damage to the component may occur. Electrical specifications do not apply when operating the device outside of its operating ratings. The maximum allowable power dissipation is a function of the maximum junction temperature,  $T_{J(max)}$ , the junction-to-ambient thermal resistance,  $\theta_{JA}$ , and the ambient temperature,  $T_A$ . The maximum allowable power dissipation at any ambient temperature is calculated using:  $P_{D(max)} = (T_{J(max)} - T_A) / \theta_{JA}$ . Exceeding the maximum allowable power dissipation will result in excessive die temperature, and the regulator will go into thermal shutdown.

## Recommended Operating Conditions

Symbol	Parameter	Min	Max	Unit
$V_{IN}$	Input Voltage	—	12	V
$T_J$	Operating Junction Temperature Range	0	+125	°C

**Electrical Characteristics** (Typicals and limits appearing in normal type apply for  $T_J = +25^\circ\text{C}$ . Limits appearing in **Boldface** type apply over the entire operating junction temperature range 0 to +125°C.)

Symbol	Parameter	Conditions	Min	Typ	Max	Unit
$V_{REF}$	Reference Voltage	AZ1085C-ADJ, $I_{OUT} = 10\text{mA}$ , $V_{IN} - V_{OUT} = 3\text{V}$ , $T_J = +25^\circ\text{C}$ , $10\text{mA} \leq I_{OUT} \leq 3\text{A}$ , $1.5\text{V} \leq V_{IN} - V_{OUT} \leq 5\text{V}$	1.238 <b>1.225</b>	1.250 <b>1.250</b>	1.262 <b>1.275</b>	V
$V_{OUT}$	Output Voltage	AZ1085C-1.5, $I_{OUT} = 0\text{mA}$ , $V_{IN} = 4.5\text{V}$ , $T_J = +25^\circ\text{C}$ , $10\text{mA} \leq I_{OUT} \leq 3\text{A}$ , $3.0\text{V} \leq V_{IN} \leq 6\text{V}$	1.485 <b>1.47</b>	1.5 <b>1.5</b>	1.515 <b>1.53</b>	V
		AZ1085C-1.8, $I_{OUT} = 0\text{mA}$ , $V_{IN} = 4.8\text{V}$ , $T_J = +25^\circ\text{C}$ , $10\text{mA} \leq I_{OUT} \leq 3\text{A}$ , $3.3\text{V} \leq V_{IN} \leq 7\text{V}$	1.782 <b>1.764</b>	1.8 <b>1.8</b>	1.818 <b>1.836</b>	V
		AZ1085C-2.5, $I_{OUT} = 0\text{mA}$ , $V_{IN} = 5.5\text{V}$ , $T_J = +25^\circ\text{C}$ , $10\text{mA} \leq I_{OUT} \leq 3\text{A}$ , $4.0\text{V} \leq V_{IN} \leq 7\text{V}$	2.475 <b>2.45</b>	2.5 <b>2.5</b>	2.525 <b>2.55</b>	V
		AZ1085C-3.3, $I_{OUT} = 0\text{mA}$ , $V_{IN} = 6.3\text{V}$ , $T_J = +25^\circ\text{C}$ , $10\text{mA} \leq I_{OUT} \leq 3\text{A}$ , $4.8\text{V} \leq V_{IN} \leq 8\text{V}$	3.267 <b>3.234</b>	3.3 <b>3.3</b>	3.333 <b>3.366</b>	V
		AZ1085C-5.0, $I_{OUT} = 0\text{mA}$ , $V_{IN} = 8\text{V}$ , $T_J = +25^\circ\text{C}$ , $10\text{mA} \leq I_{OUT} \leq 3\text{A}$ , $6.5\text{V} \leq V_{IN} \leq 10\text{V}$	4.95 <b>4.9</b>	5 <b>5</b>	5.05 <b>5.1</b>	V
$\Delta V_{OUT}$	Line Regulation	AZ1085C-ADJ, $I_{OUT} = 10\text{mA}$ , $2.85\text{V} \leq V_{IN} \leq 10\text{V}$	—	0.015 <b>0.035</b>	0.2 <b>0.2</b>	%
		AZ1085C-1.5, $I_{OUT} = 10\text{mA}$ , $3.0\text{V} \leq V_{IN} \leq 10\text{V}$	—	0.5 <b>1</b>	6 <b>6</b>	mV
		AZ1085C-1.8, $I_{OUT} = 10\text{mA}$ , $3.3\text{V} \leq V_{IN} \leq 10\text{V}$	—	0.5 <b>1</b>	6 <b>6</b>	mV
		AZ1085C-2.5, $I_{OUT} = 10\text{mA}$ , $4.0\text{V} \leq V_{IN} \leq 10\text{V}$	—	0.5 <b>1</b>	6 <b>6</b>	mV
		AZ1085C-3.3, $I_{OUT} = 10\text{mA}$ , $4.8\text{V} \leq V_{IN} \leq 10\text{V}$	—	0.5 <b>1</b>	6 <b>6</b>	mV
		AZ1085C-5.0, $I_{OUT} = 10\text{mA}$ , $6.5\text{V} \leq V_{IN} \leq 10\text{V}$	—	0.5 <b>1</b>	10 <b>10</b>	mV

**Electrical Characteristics** (Cont. Typicals and limits appearing in normal type apply for  $T_J = +25^\circ\text{C}$ . Limits appearing in **Boldface** type apply over the entire operating junction temperature range 0 to  $+125^\circ\text{C}$ .)

Symbol	Parameter	Conditions	Min	Typ	Max	Unit
$\Delta V_{OUT}$	Load Regulation	AZ1085C-ADJ, $0\text{mA} \leq I_{OUT} \leq 3\text{A}$ , $V_{IN}-V_{OUT} = 3\text{V}$	—	0.1 <b>0.2</b>	0.3 <b>0.4</b>	%
		AZ1085C-1.5, $0\text{mA} \leq I_{OUT} \leq 3\text{A}$ , $V_{IN}-V_{OUT} = 3\text{V}$	—	3 <b>7</b>	15 <b>20</b>	mV
		AZ1085C-1.8, $0\text{mA} \leq I_{OUT} \leq 3\text{A}$ , $V_{IN}-V_{OUT} = 3\text{V}$	—	3 <b>7</b>	15 <b>20</b>	mV
		AZ1085C-2.5, $0\text{mA} \leq I_{OUT} \leq 3\text{A}$ , $V_{IN}-V_{OUT} = 3\text{V}$	—	3 <b>7</b>	15 <b>20</b>	mV
		AZ1085C-3.3, $0\text{mA} \leq I_{OUT} \leq 3\text{A}$ , $V_{IN}-V_{OUT} = 3\text{V}$	—	3 <b>7</b>	15 <b>20</b>	mV
		AZ1085C-5.0, $0\text{mA} \leq I_{OUT} \leq 3\text{A}$ , $V_{IN}-V_{OUT} = 3\text{V}$	—	5 <b>10</b>	20 <b>35</b>	mV
$V_{DROP}$	Dropout Voltage	$I_{OUT} = 3\text{A}$ , $\Delta V_{REF}$ , $\Delta V_{OUT} = 1\%$	—	<b>1.3</b>	<b>1.5</b>	V
$\theta_{JC}$	Thermal Resistance (Junction to Case)	TO263	—	6.34	—	$^\circ\text{C/W}$
		TO263-2	—	6.34	—	
		TO252-2 (3)/TO252-2 (4)/TO252-2 (5)	—	7.36	—	
$I_{LIMIT}$	Current Limit	$V_{IN}-V_{OUT} = 3\text{V}$	3.2	4.5	—	A
$I_{LOAD (MIN)}$	Minimum Load Current	$V_{IN} = 10\text{V}$ (AZ1085C-ADJ)	—	<b>3</b>	<b>10</b>	mA
$I_Q$	Quiescent Current	$V_{IN} = 10\text{V}$ (AZ1085C)	—	<b>5</b>	<b>10</b>	mA
PSRR	Ripple Rejection	$f_{RIPPLE} = 120\text{Hz}$ , $C_{OUT} = 25\mu\text{F}$ , $I_{OUT} = 3\text{A}$ , $V_{IN}-V_{OUT} = 3\text{V}$	<b>60</b>	<b>72</b>	—	dB
$I_{ADJ}$	Adjust Pin Current	$V_{IN} = 4.25\text{V}$ , $I_{OUT} = 10\text{mA}$	—	55	<b>120</b>	$\mu\text{A}$
$\Delta I_{ADJ}$	Adjust Pin Current Change	$10\text{mA} \leq I_{OUT} \leq 3\text{A}$ , $1.5\text{V} \leq V_{IN}-V_{OUT} \leq 6\text{V}$	—	<b>0.2</b>	<b>5</b>	$\mu\text{A}$
—	Long Term Stability	$T_A = +125^\circ\text{C}$ , 1000Hrs	—	0.5	—	%
—	Temperature Stability	$I_{OUT} = 10\text{mA}$ , $V_{IN}-V_{OUT} = 1.5\text{V}$	—	<b>0.5</b>	—	%
—	RMS Noise (% of $V_{OUT}$ )	$T_A = +25^\circ\text{C}$ , $10\text{Hz} \leq f \leq 10\text{kHz}$	—	0.003	—	%

**Performance Characteristics**

**Line Regulation vs. Junction Temperature**

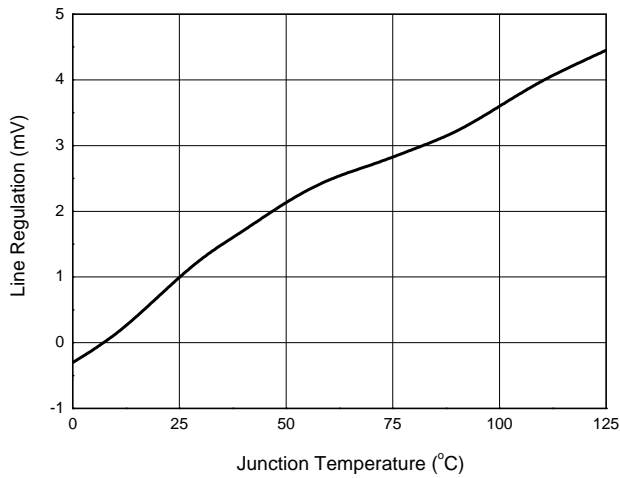

**Load Regulation vs. Junction Temperature**

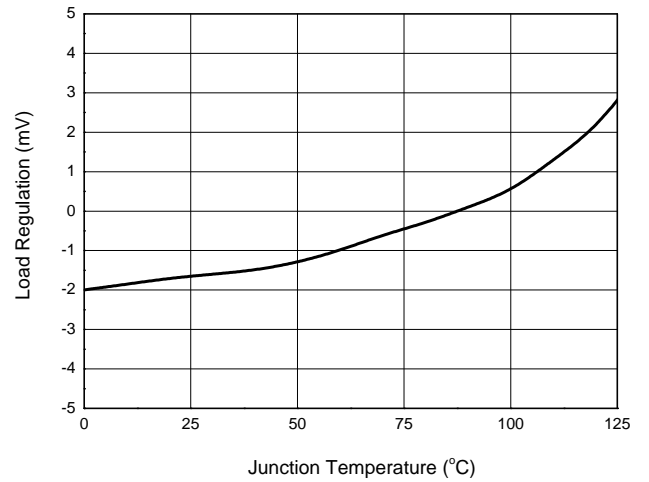

**Dropout Voltage vs. Junction Temperature**

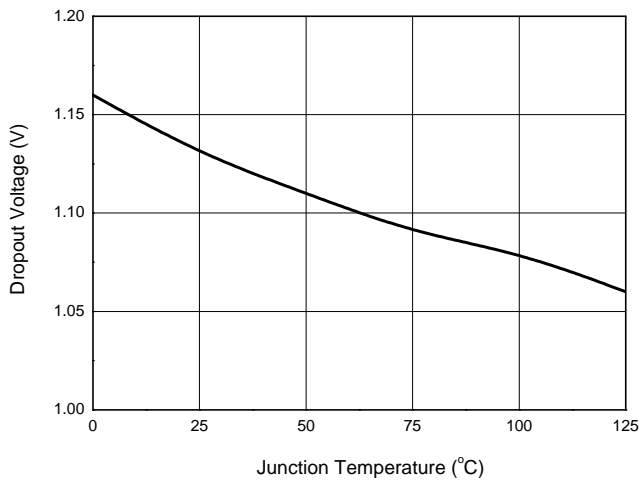

**Output Voltage vs. Junction Temperature**

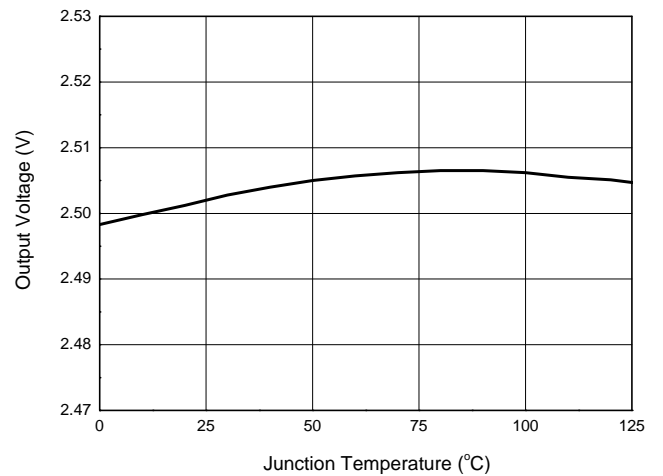

**Short Circuit Current vs. Dropout Voltage**

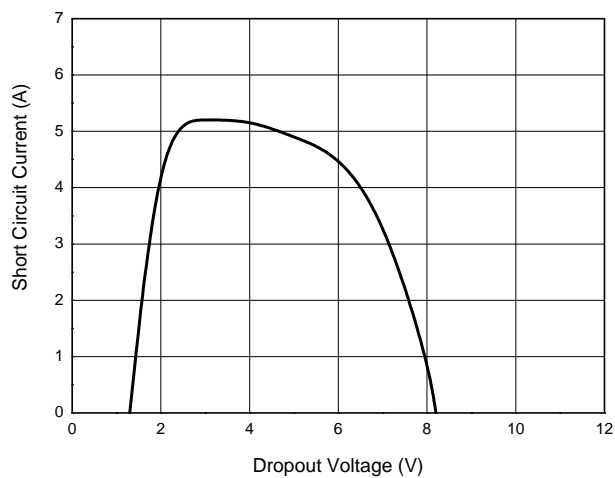

**Dropout Voltage vs. Output Current**

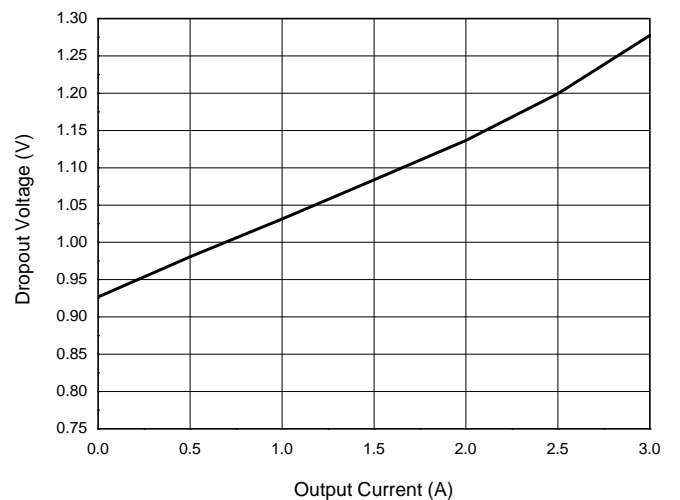

**Performance Characteristics (Cont.)**

**Reference Voltage vs. Junction Temperature**

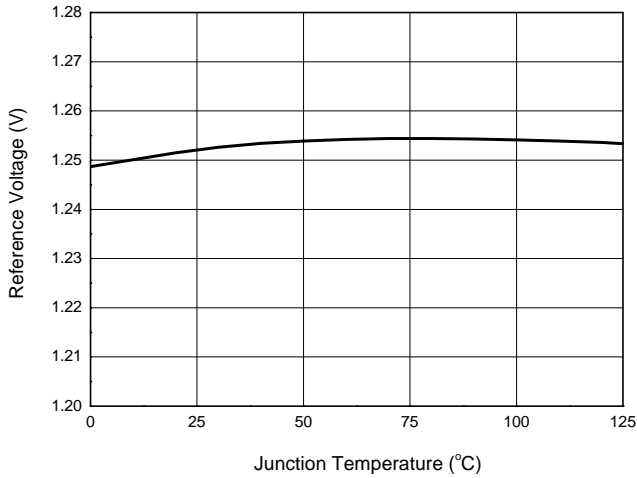

**Minimum Load Current vs. Junction Temperature**

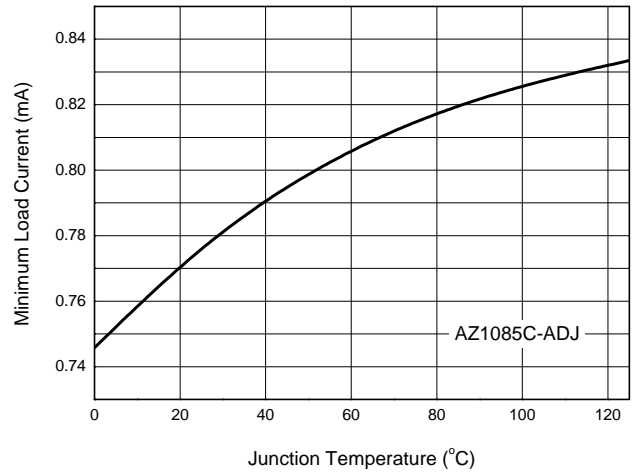

**Adjust Pin Current vs. Junction Temperature**

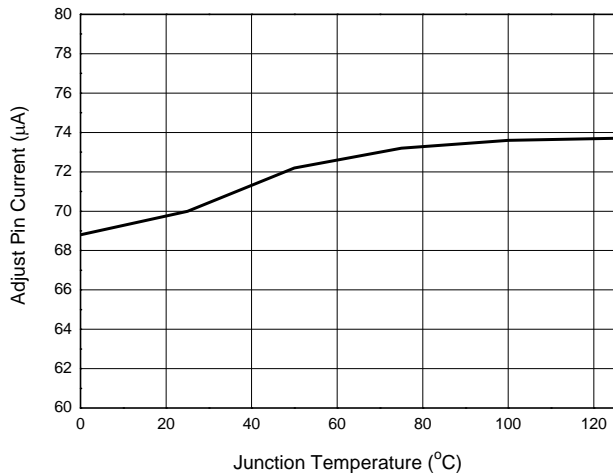

**Adjust Pin Current vs. Output Current**

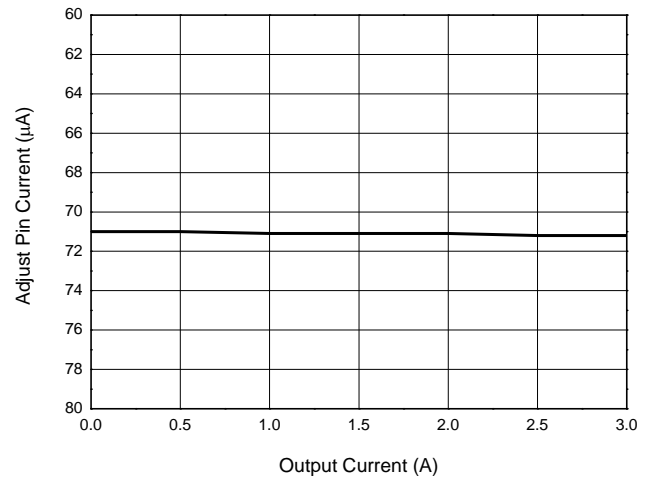

**Load Transient Response**  
(Conditions:  $V_{IN} = 5.5V$ ,  $V_{OUT} = 2.5V$ ,  
 $I_{OUT} = 100mA$  to  $3A$ ,  $C_{IN} = C_{OUT} = 10\mu F$ )

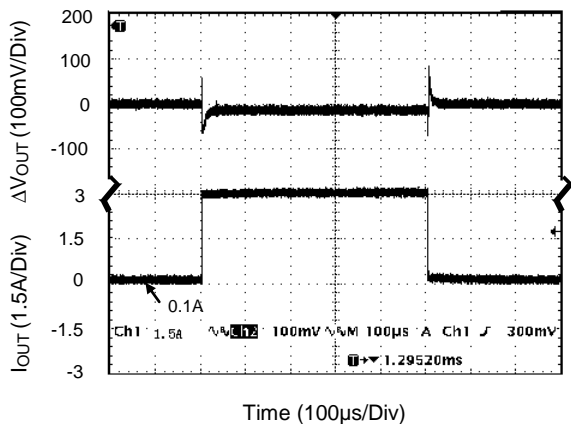

**Line Transient Response**  
(Conditions:  $V_{IN} = 4.5V$  to  $6.5V$ ,  $V_{OUT} = 2.5V$ ,  
 $I_{OUT} = 200mA$ ,  $C_{IN} = 1\mu F$ ,  $C_{OUT} = 10\mu F$ )

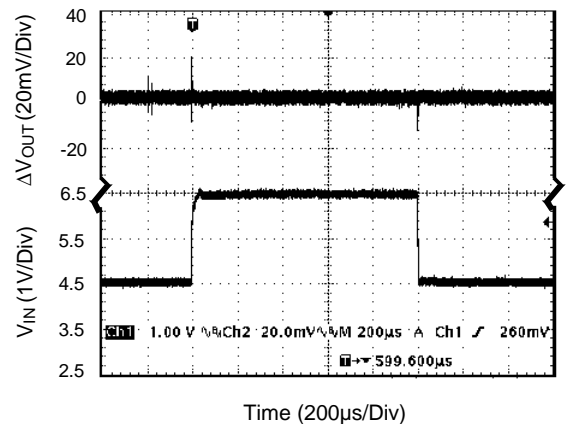

**Performance Characteristics (Cont.)**

**Power Dissipation vs. Case Temperature**

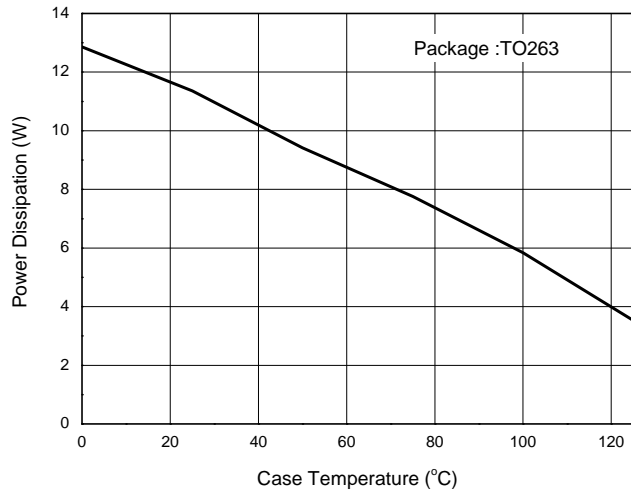

**PSRR vs. Frequency**

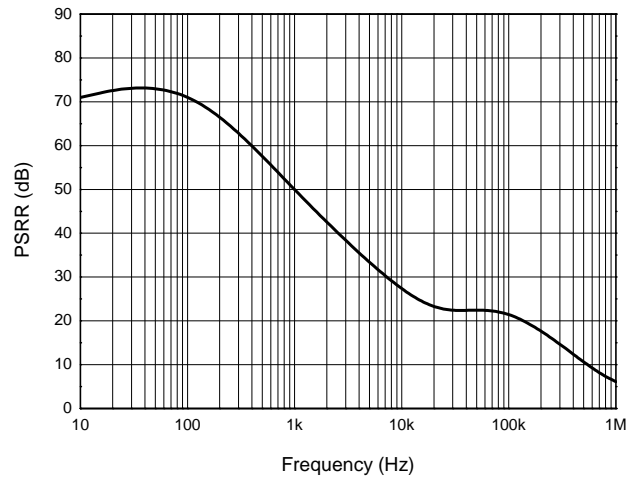

## Ordering Information

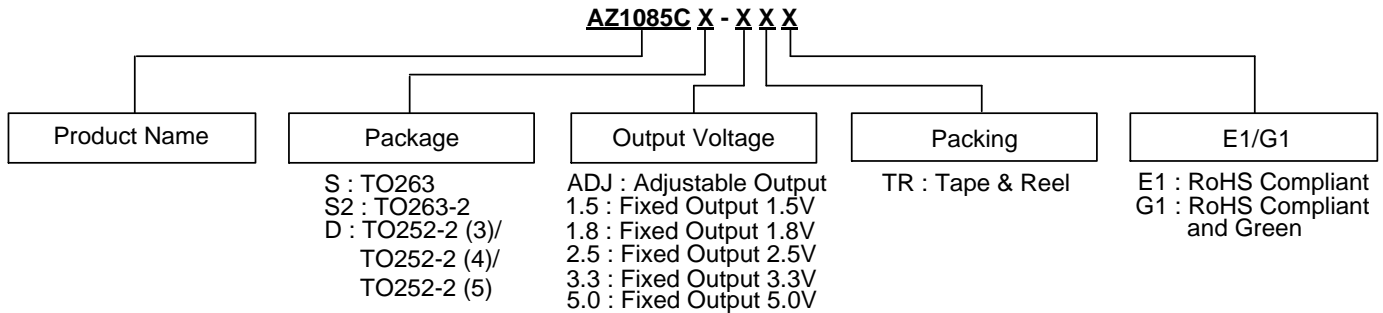

Package	Temperature Range	Part Number		Marking ID		Packing
		RoHS Compliant	RoHS Compliant and Green	RoHS Compliant	RoHS Compliant and Green	
TO263	0 to +125°C	AZ1085CS-ADJTRE1	AZ1085CS-ADJTRG1	AZ1085CS-ADJE1	AZ1085CS-ADJG1	800/Tape & Reel
TO263	0 to +125°C	AZ1085CS-1.5TRE1	AZ1085CS-1.5TRG1	AZ1085CS-1.5E1	AZ1085CS-1.5G1	800/Tape & Reel
TO263	0 to +125°C	AZ1085CS-1.8TRE1	AZ1085CS-1.8TRG1	AZ1085CS-1.8E1	AZ1085CS-1.8G1	800/Tape & Reel
TO263	0 to +125°C	AZ1085CS-2.5TRE1	AZ1085CS-2.5TRG1	AZ1085CS-2.5E1	AZ1085CS-2.5G1	800/Tape & Reel
TO263	0 to +125°C	AZ1085CS-3.3TRE1	AZ1085CS-3.3TRG1	AZ1085CS-3.3E1	AZ1085CS-3.3G1	800/Tape & Reel
TO263	0 to +125°C	AZ1085CS-5.0TRE1	AZ1085CS-5.0TRG1	AZ1085CS-5.0E1	AZ1085CS-5.0G1	800/Tape & Reel
TO263-2	0 to +125°C	AZ1085CS2-ADJTRE1	AZ1085CS2-ADJTRG1	AZ1085CS2-ADJE1	AZ1085CS2-ADJG1	800/Tape & Reel
TO263-2	0 to +125°C	AZ1085CS2-1.5TRE1	AZ1085CS2-1.5TRG1	AZ1085CS2-1.5E1	AZ1085CS2-1.5G1	800/Tape & Reel
TO263-2	0 to +125°C	AZ1085CS2-1.8TRE1	AZ1085CS2-1.8TRG1	AZ1085CS2-1.8E1	AZ1085CS2-1.8G1	800/Tape & Reel
TO263-2	0 to +125°C	AZ1085CS2-2.5TRE1	AZ1085CS2-2.5TRG1	AZ1085CS2-2.5E1	AZ1085CS2-2.5G1	800/Tape & Reel
TO263-2	0 to +125°C	AZ1085CS2-3.3TRE1	AZ1085CS2-3.3TRG1	AZ1085CS2-3.3E1	AZ1085CS2-3.3G1	800/Tape & Reel
TO263-2	0 to +125°C	AZ1085CS2-5.0TRE1	AZ1085CS2-5.0TRG1	AZ1085CS2-5.0E1	AZ1085CS2-5.0G1	800/Tape & Reel
TO252-2 (3)/(4)/(5)	0 to +125°C	—	AZ1085CD-ADJTRG1	—	AZ1085CD-ADJG1	2500/Tape & Reel
TO252-2 (3)/(4)/(5)	0 to +125°C	—	AZ1085CD-1.5TRG1	—	AZ1085CD-1.5G1	2500/Tape & Reel
TO252-2 (3)/(4)/(5)	0 to +125°C	—	AZ1085CD-1.8TRG1	—	AZ1085CD-1.8G1	2500/Tape & Reel
TO252-2 (3)/(4)/(5)	0 to +125°C	—	AZ1085CD-2.5TRG1	—	AZ1085CD-2.5G1	2500/Tape & Reel
TO252-2 (3)/(4)/(5)	0 to +125°C	—	AZ1085CD-3.3TRG1	—	AZ1085CD-3.3G1	2500/Tape & Reel
TO252-2 (3)/(4)/(5)	0 to +125°C	—	AZ1085CD-5.0TRG1	—	AZ1085CD-5.0G1	2500/Tape & Reel

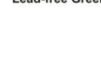

**Marking Information**

(1) TO252-2 Series

(Top View)

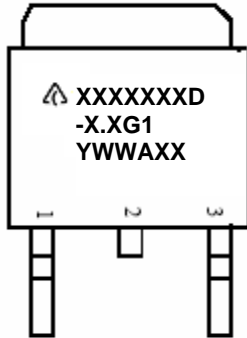

First and Second Lines: Logo and Marking ID  
(See Ordering Information)  
Third Line: Date Code  
Y: Year  
WW: Work Week of Molding  
A: Assembly House Code  
XX: 7th and 8th Digits of Batch Number

(2) TO263-2 Series

(Top View)

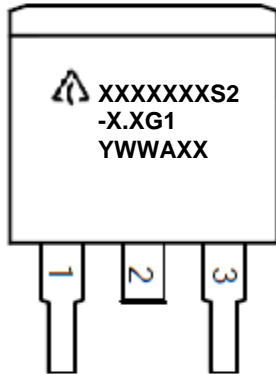

First and Second Lines: Logo and Marking ID  
(See Ordering Information) (G1 may be E1 depending on product)  
Third Line: Date Code  
Y: Year  
WW: Work Week of Molding  
A: Assembly House Code  
XX: 7th and 8th Digits of Batch Number

(3) TO263 Series

(Top View)

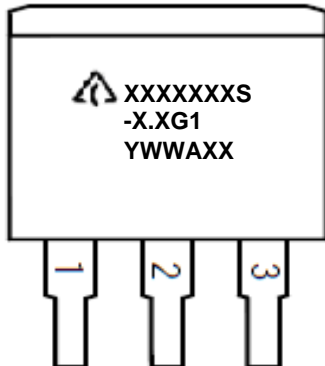

First and Second Lines: Logo and Marking ID  
(See Ordering Information) (G1 may be E1 depending on product)  
Third Line: Date Code  
Y: Year  
WW: Work Week of Molding  
A: Assembly House Code  
XX: 7th and 8th Digits of Batch Number

**Package Outline Dimensions** (All dimensions in mm(inch).)

(1) Package Type: TO263

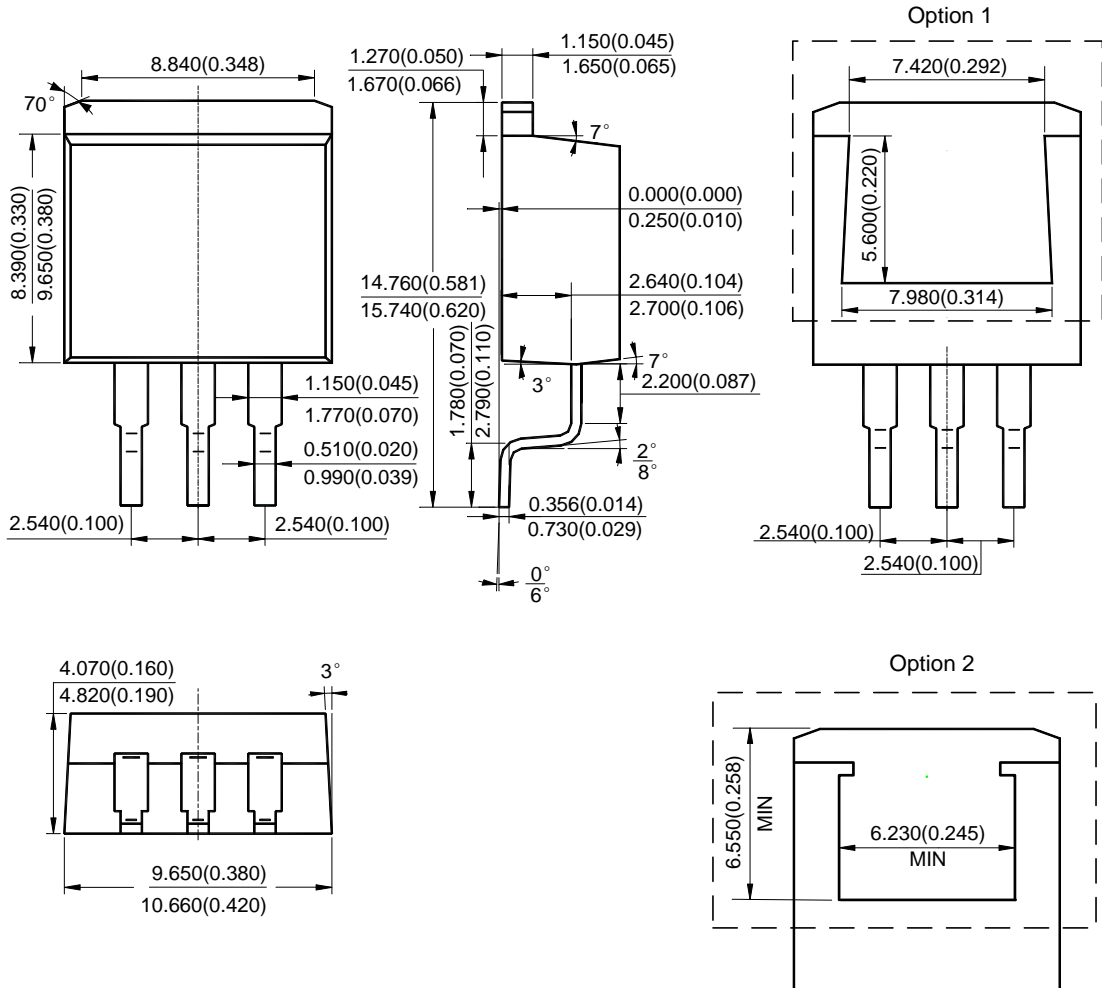



**Package Outline Dimensions** (Cont. All dimensions in mm(inch).)

(3) Package Type: TO252-2 (3)

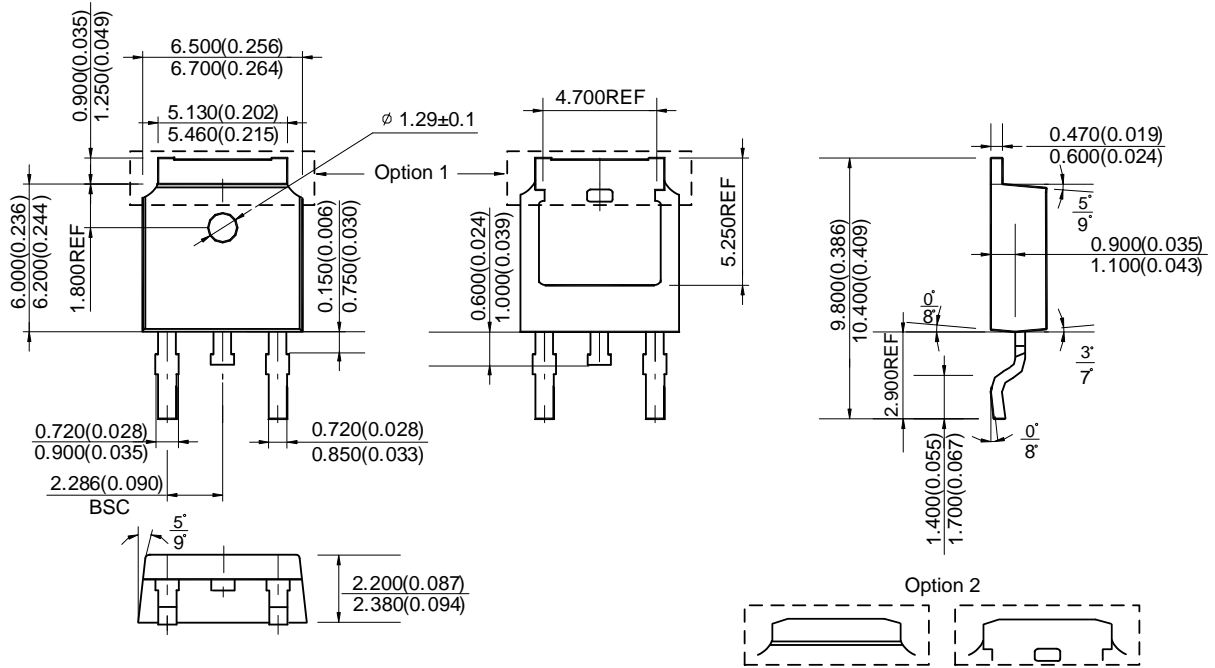

**Package Outline Dimensions** (Cont. All dimensions in mm(inch).)

(4) Package Type: TO252-2 (4)

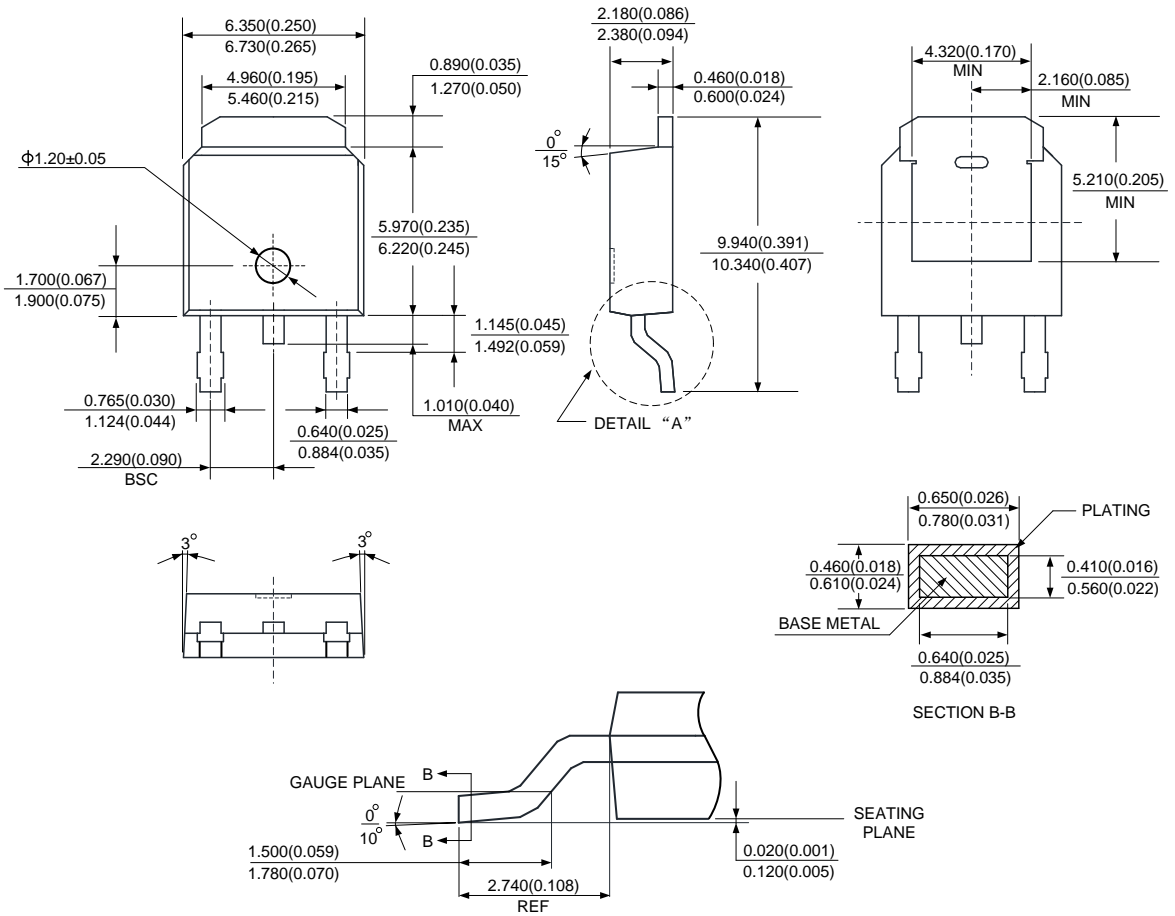

**Package Outline Dimensions** (Cont. All dimensions in mm(inch).)

(5) Package Type: TO252-2 (5)

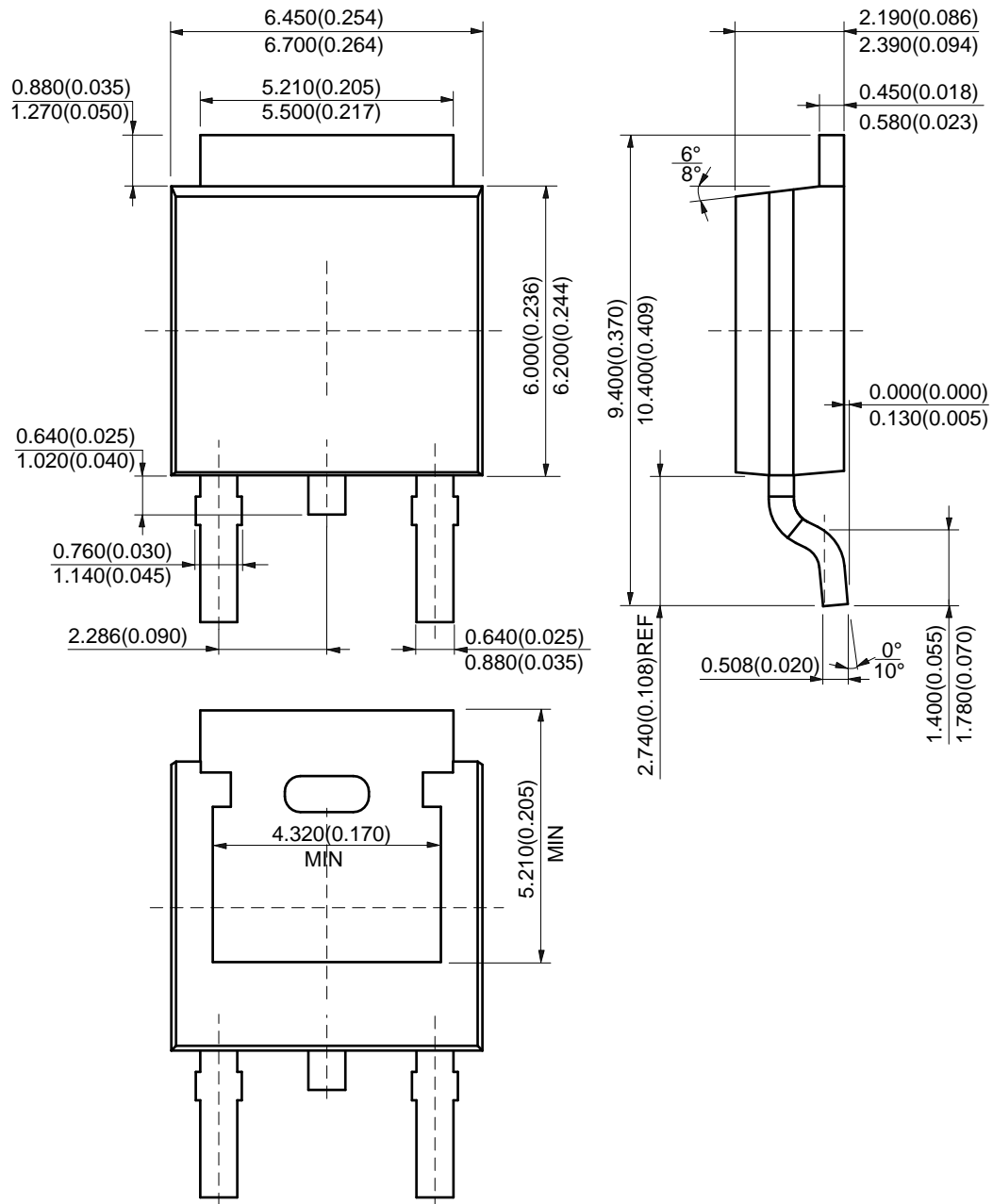

**Suggested Pad Layout**

(1) Package Type: TO263

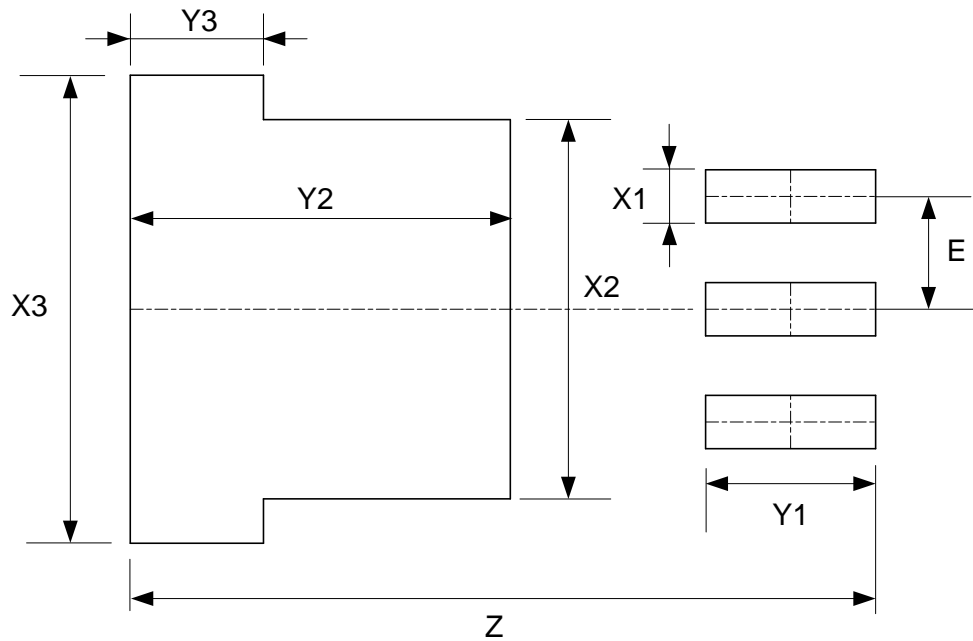

Dimensions	Z (mm)/(inch)	X1 (mm)/(inch)	X2 (mm)/(inch)	X3 (mm)/(inch)
Value	16.760/0.660	1.200/0.047	8.540/0.336	10.540/0.415
Dimensions	Y1 (mm)/(inch)	Y2 (mm)/(inch)	Y3 (mm)/(inch)	E (mm)/(inch)
Value	3.830/0.151	8.560/0.337	3.000/0.118	2.540/0.100

**Suggested Pad Layout (Cont.)**

(2) Package Type: TO263-2

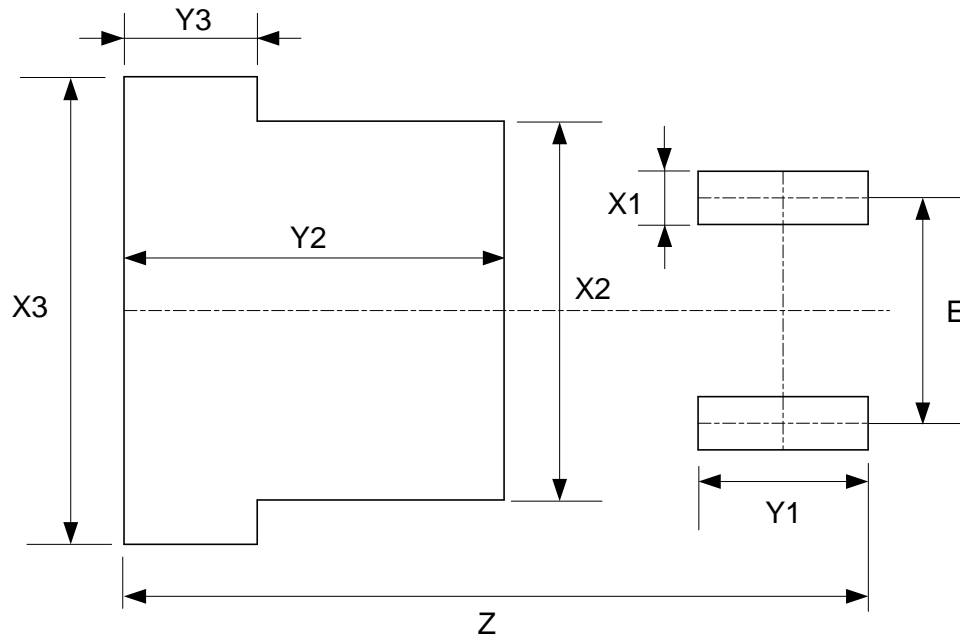

Dimensions	Z (mm)/(inch)	X1 (mm)/(inch)	X2 (mm)/(inch)	X3 (mm)/(inch)
Value	16.760/0.660	1.200/0.047	8.540/0.336	10.540/0.415
Dimensions	Y1 (mm)/(inch)	Y2 (mm)/(inch)	Y3 (mm)/(inch)	E (mm)/(inch)
Value	3.830/0.151	8.560/0.337	3.000/0.118	5.080/0.200

**Suggested Pad Layout (Cont.)**

(3) Package Type: TO252-2 (3)

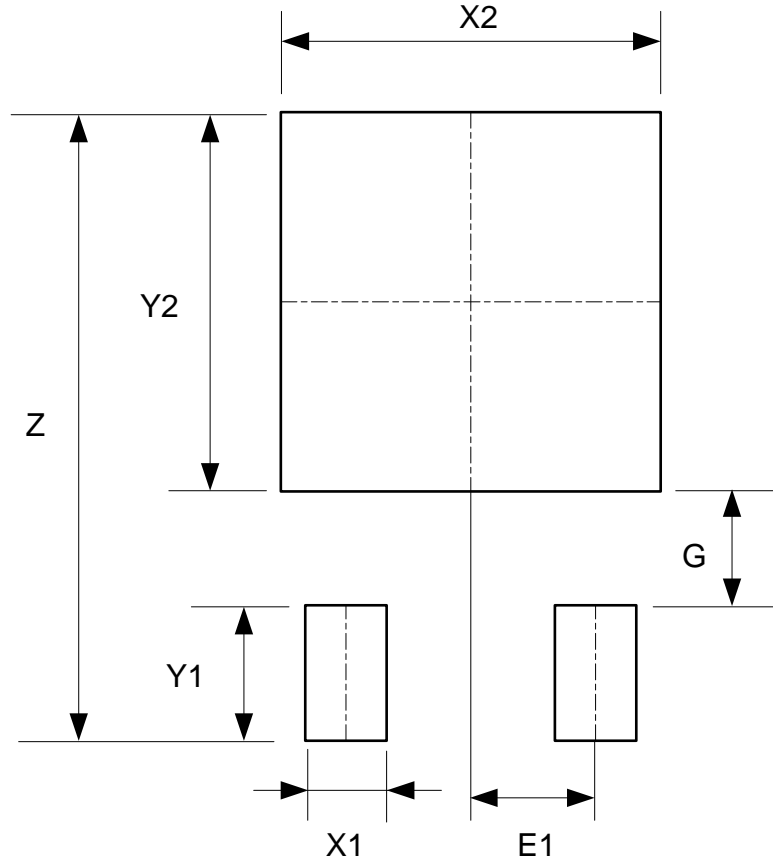

Dimensions	Z (mm)/(inch)	X1 (mm)/(inch)	X2=Y2 (mm)/(inch)	Y1 (mm)/(inch)	G (mm)/(inch)	E1 (mm)/(inch)
Value	11.600/0.457	1.500/0.059	7.000/0.276	2.500/0.098	2.100/0.083	2.300/0.091

**Suggested Pad Layout (Cont.)**

(4) Package Type: TO252-2 (4)

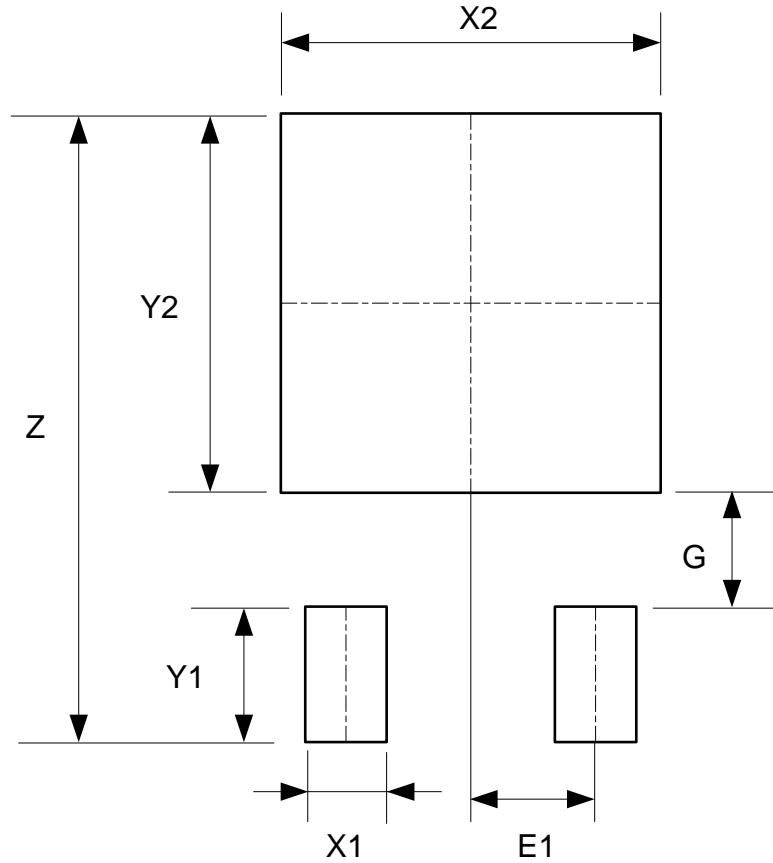

Dimensions	Z (mm)/(inch)	X1 (mm)/(inch)	X2=Y2 (mm)/(inch)	Y1 (mm)/(inch)	G (mm)/(inch)	E1 (mm)/(inch)
Value	11.600/0.457	1.500/0.059	7.000/0.276	2.500/0.098	2.100/0.083	2.300/0.091

**Suggested Pad Layout (Cont.)**

(5) Package Type: TO252-2 (5)

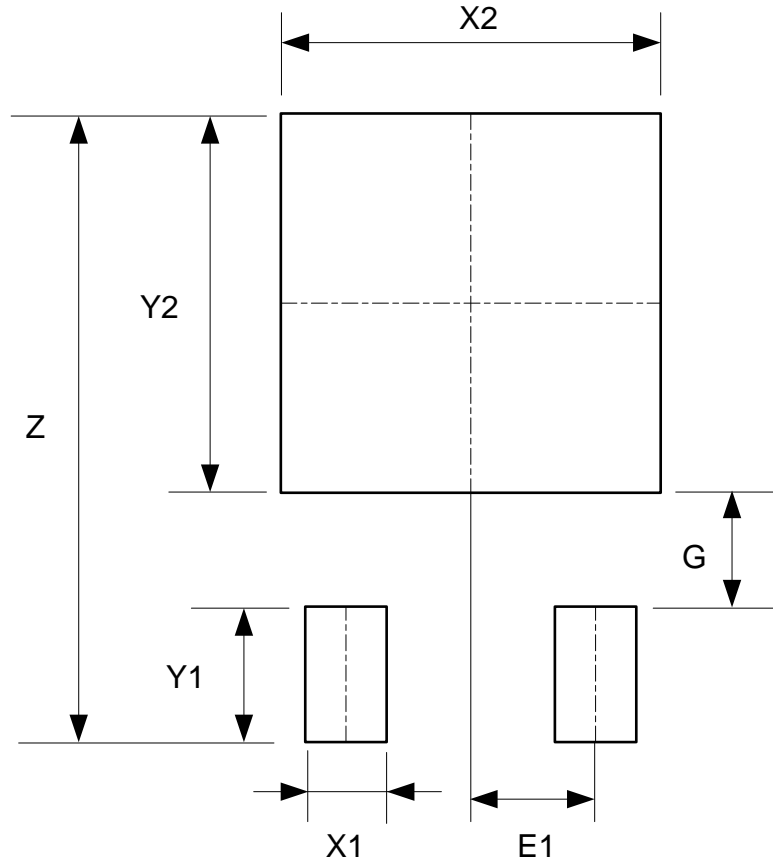

Dimensions	Z (mm)/(inch)	X1 (mm)/(inch)	X2=Y2 (mm)/(inch)	Y1 (mm)/(inch)	G (mm)/(inch)	E1 (mm)/(inch)
Value	11.600/0.457	1.500/0.059	7.000/0.276	2.500/0.098	2.100/0.083	2.300/0.091

**IMPORTANT NOTICE**

DIODES INCORPORATED MAKES NO WARRANTY OF ANY KIND, EXPRESS OR IMPLIED, WITH REGARDS TO THIS DOCUMENT, INCLUDING, BUT NOT LIMITED TO, THE IMPLIED WARRANTIES OF MERCHANTABILITY AND FITNESS FOR A PARTICULAR PURPOSE (AND THEIR EQUIVALENTS UNDER THE LAWS OF ANY JURISDICTION).

Diodes Incorporated and its subsidiaries reserve the right to make modifications, enhancements, improvements, corrections or other changes without further notice to this document and any product described herein. Diodes Incorporated does not assume any liability arising out of the application or use of this document or any product described herein; neither does Diodes Incorporated convey any license under its patent or trademark rights, nor the rights of others. Any Customer or user of this document or products described herein in such applications shall assume all risks of such use and will agree to hold Diodes Incorporated and all the companies whose products are represented on Diodes Incorporated website, harmless against all damages.

Diodes Incorporated does not warrant or accept any liability whatsoever in respect of any products purchased through unauthorized sales channel. Should Customers purchase or use Diodes Incorporated products for any unintended or unauthorized application, Customers shall indemnify and hold Diodes Incorporated and its representatives harmless against all claims, damages, expenses, and attorney fees arising out of, directly or indirectly, any claim of personal injury or death associated with such unintended or unauthorized application.

Products described herein may be covered by one or more United States, international or foreign patents pending. Product names and markings noted herein may also be covered by one or more United States, international or foreign trademarks.

This document is written in English but may be translated into multiple languages for reference. Only the English version of this document is the final and determinative format released by Diodes Incorporated.

**LIFE SUPPORT**

Diodes Incorporated products are specifically not authorized for use as critical components in life support devices or systems without the express written approval of the Chief Executive Officer of Diodes Incorporated. As used herein:

A. Life support devices or systems are devices or systems which:

1. are intended to implant into the body, or
2. support or sustain life and whose failure to perform when properly used in accordance with instructions for use provided in the labeling can be reasonably expected to result in significant injury to the user.

B. A critical component is any component in a life support device or system whose failure to perform can be reasonably expected to cause the failure of the life support device or to affect its safety or effectiveness.

Customers represent that they have all necessary expertise in the safety and regulatory ramifications of their life support devices or systems, and acknowledge and agree that they are solely responsible for all legal, regulatory and safety-related requirements concerning their products and any use of Diodes Incorporated products in such safety-critical, life support devices or systems, notwithstanding any devices- or systems-related information or support that may be provided by Diodes Incorporated. Further, Customers must fully indemnify Diodes Incorporated and its representatives against any damages arising out of the use of Diodes Incorporated products in such safety-critical, life support devices or systems.

Copyright © 2018, Diodes Incorporated

[www.diodes.com](http://www.diodes.com)

## Looking for pricing, stock, or lifecycle information?

Click below to explore more details on WIN SOURCE:

- ⊖ [View AZ1085CS2-ADJTRE1 on WIN SOURCE](#)
- ⊖ [Diodes Incorporated Information](#)

## Optimize Your Supply Chain with WIN SOURCE Solutions

- ✓ Global Sourcing Solution
- ✓ Obsolete Management
- ✓ Cost Control Management
- ✓ Shortage Management
- ✓ Alternative Solution
- ✓ Excess Inventory Management