



**THE DATASHEET OF
SN74TVC3010DW**



- **Designed to be Used in Voltage-Limiting Applications**
- **6.5-Ω On-State Connection Between Ports A and B**
- **Flow-Through Pinout for Ease of Printed Circuit Board Trace Routing**
- **Direct Interface With GTL+ Levels**
- **ESD Protection Exceeds JESD 22**
 - 2000-V Human-Body Model (A114-A)
 - 1000-V Charged-Device Model (C101)

**DBQ, DGV, DW, OR PW PACKAGE
(TOP VIEW)**

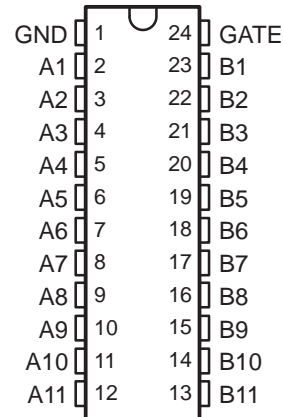

description/ordering information

The SN74TVC3010 provides 11 parallel NMOS pass transistors with a common gate. The low on-state resistance of the switch allows connections to be made with minimal propagation delay.

The device can be used as a 10-bit switch with the gates cascaded together to a reference transistor. The low-voltage side of each pass transistor is limited to a voltage set by the reference transistor. This is done to protect components with inputs that are sensitive to high-state voltage-level overshoots. (See Application Information in this data sheet.)

All of the transistors in the TVC array have the same electrical characteristics; therefore, any one of them can be used as the reference transistor. Since, within the device, the characteristics from transistor to transistor are equal, the maximum output high-state voltage (V_{OH}) is approximately the reference voltage (V_{REF}), with minimal deviation from one output to another. This is a large benefit of the TVC solution over discrete devices. Because the fabrication of the transistors is symmetrical, either port connection of each bit can be used as the low-voltage side, and the I/O signals are bidirectional through each FET.

ORDERING INFORMATION

T _A	PACKAGE†	ORDERABLE PART NUMBER	TOP-SIDE MARKING	
–40°C to 85°C	SOIC – DW	Tube	SN74TVC3010DW	
		Tape and reel	SN74TVC3010DWR	
	SSOP (QSOP) – DBQ	Tape and reel	SN74TVC3010DBQR	TVC3010
	TSSOP – PW	Tape and reel	SN74TVC3010PWR	TT010
	TVSOP – DGV	Tape and reel	SN74TVC3010DGVR	TT010

† Package drawings, standard packing quantities, thermal data, symbolization, and PCB design guidelines are available at www.ti.com/sc/package.



Please be aware that an important notice concerning availability, standard warranty, and use in critical applications of Texas Instruments semiconductor products and disclaimers thereto appears at the end of this data sheet.

PRODUCTION DATA information is current as of publication date. Products conform to specifications per the terms of Texas Instruments standard warranty. Production processing does not necessarily include testing of all parameters.



POST OFFICE BOX 655303 • DALLAS, TEXAS 75265

Copyright © 2003, Texas Instruments Incorporated

application operating conditions (see Figure 3)

		MIN	TYP	MAX	UNIT
VBIAS	BIAS voltage	VREF + 0.6	2.1	5	V
VGATE	GATE voltage	VREF + 0.6	2.1	5	V
VREF	Reference voltage	0	1.5	4.4	V
V _{DPU}	Drain pullup voltage	2.36	2.5	2.64	V
I _{PASS}	Pass-transistor current		14		mA
I _{REF}	Reference-transistor current		5		μA
T _A	Operating free-air temperature	-40		85	°C

electrical characteristics over recommended operating free-air temperature range (unless otherwise noted)

PARAMETER	TEST CONDITIONS			MIN	TYP†	MAX	UNIT
V _{IK}	V _{BIAS} = 0,	I _I = -18 mA				-1.2	V
V _{OL}	I _{REF} = 5 μA, V _{DPU} = 2.625 V,	V _{REF} = 1.365 V, R _{DPU} = 150 Ω	V _S = 0.175 V, See Figure 1			350	mV
C _{i(GATE)}	V _I = 3 V or 0				24		pF
C _{io(off)}	V _O = 3 V or 0				4	12	pF
C _{io(on)}	V _O = 3 V or 0				12	30	pF
r _{on‡}	I _{REF} = 5 μA, V _{DPU} = 2.625 V,	V _{REF} = 1.365 V, R _{DPU} = 150 Ω	V _S = 0.175 V, See Figure 1			12.5	Ω

† All typical values are at T_A = 25°C.

‡ Measured by the voltage drop between the A and B terminals at the indicated current through the switch. On-state resistance is determined by the lowest voltage of the two (A or B) terminals.

switching characteristics over recommended operating free-air temperature range, V_{DPU} = 2.36 V to 2.64 V (unless otherwise noted) (see Figure 1)

PARAMETER	FROM (INPUT)	TO (OUTPUT)	MIN	MAX	UNIT
t _{PLH}	A or B	B or A	0	4	ns
t _{PHL}			0	4	

SN74TVC3010 10-BIT VOLTAGE CLAMP

SCDS088G – APRIL 1999 – REVISED AUGUST 2003

PARAMETER MEASUREMENT INFORMATION

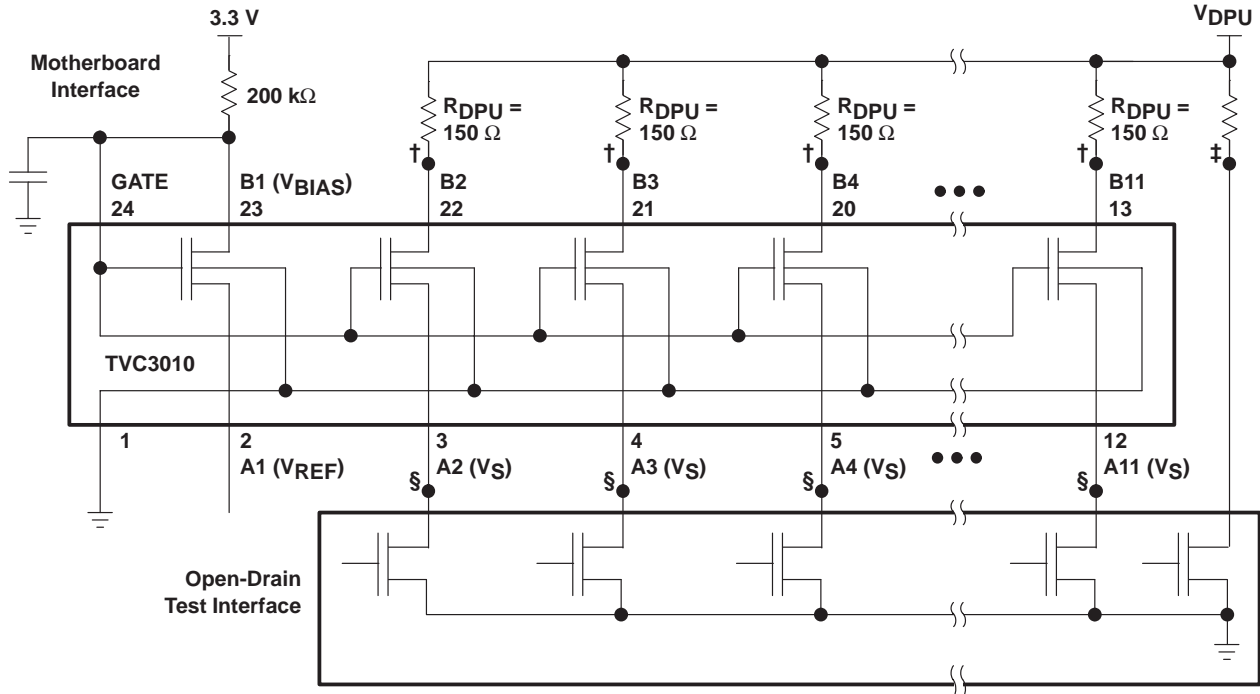

TESTER CALIBRATION SETUP (see Note C)

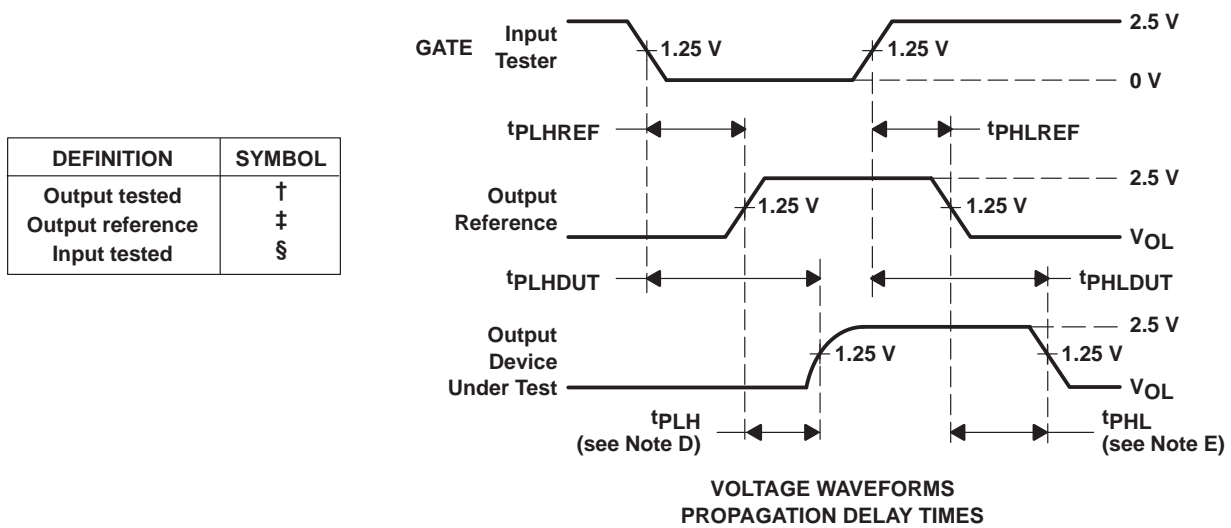

- NOTES:
- A. All input pulses are supplied by generators having the following characteristics: $PRR \leq 10 \text{ MHz}$, $Z_O = 50 \Omega$, $t_r \leq 2 \text{ ns}$, $t_f \leq 2 \text{ ns}$.
 - B. The outputs are measured one at a time with one transition per measurement.
 - C. Test procedure: t_{PLHREF} and t_{PHLREF} are obtained by measuring the propagation delay of a reference measuring point. t_{PLHDUT} and t_{PHLDUT} are obtained by measuring the propagation delay of the device under test.
 - D. $t_{PLH} = t_{PLHDUT} - t_{PLHREF}$
 - E. $t_{PHL} = t_{PHLDUT} - t_{PHLREF}$

Figure 1. Tester Calibration Setup and Voltage Waveforms

APPLICATION INFORMATION

TVC background information

In personal computer (PC) architecture, there are industry-accepted bus standards. These standards define, among other things, the I/O voltage levels at which the bus communicates. Examples include the GTL+ host bus, the AGP graphics port, and the PCI local bus. In new designs, the system components must communicate with existing bus infrastructure. Providing an evolutionary upgrade path is important in the design of PC architecture, but the existing bus standards must be preserved.

To achieve the ever-present need for smaller, faster, lighter devices that draw less power, yet have faster performance, most new high-performance digital integrated circuits are being designed and produced with advanced submicron semiconductor process technologies. These devices have thin gate-oxide or short channel lengths and very low absolute-maximum voltages that can be tolerated at the inputs/outputs (I/Os) without causing damage. In many cases, the I/Os of these devices are not tolerant of the high-state voltage levels on the preexisting buses with which they must communicate. Therefore, it became necessary to protect the I/Os of devices by limiting the I/O voltages.

The Texas Instruments (TI) translation voltage-clamp (TVC) family was designed specifically for protecting sensitive I/Os (see Figure 2). The information in this data sheet describes the I/O-protection application of the TVC family and should enable the design engineer to successfully implement an I/O-protection circuit utilizing the TI TVC solution.

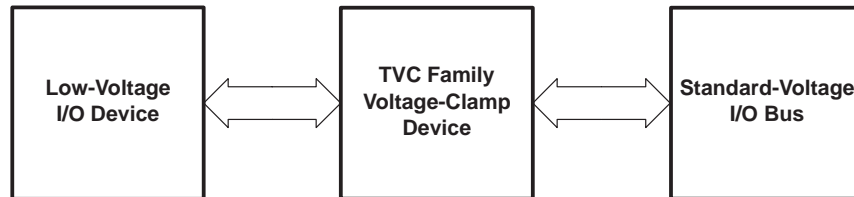

Figure 2. Thin Gate-Oxide Protection Application

SN74TVC3010 10-BIT VOLTAGE CLAMP

SCDS088G – APRIL 1999 – REVISED AUGUST 2003

APPLICATION INFORMATION

TVC voltage-limiting application

For the voltage-limiting configuration, the common GATE input must be connected to one side (A or B) of any one of the transistors (see Figure 3). This connection determines the V_{BIAS} input of the reference transistor. The V_{BIAS} input is connected through a pullup resistor (typically, 200 k Ω) to the V_{DD} supply. A filter capacitor on V_{BIAS} is recommended. The opposite side of the reference transistor is used as the reference voltage (V_{REF}) connection. The V_{REF} input must be less than $V_{DDREF} - 1$ V to bias the reference transistor into conduction. The reference transistor regulates the gate voltage (V_{GATE}) of all the pass transistors. V_{GATE} is determined by the characteristic gate-to-source voltage difference (V_{GS}) because $V_{GATE} = V_{REF} + V_{GS}$. The low-voltage side of the pass transistors has a high-level voltage limited to a maximum of $V_{GATE} - V_{GS}$, or V_{REF} .

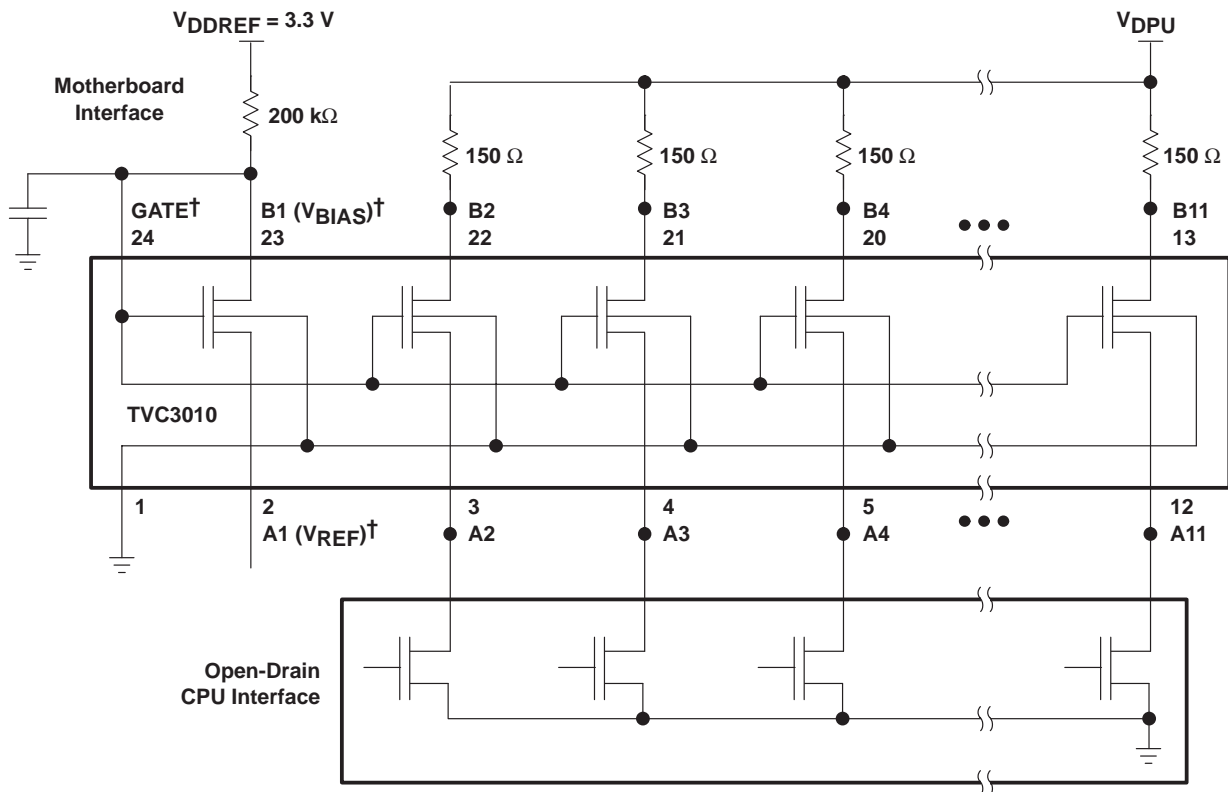

† V_{REF} and V_{BIAS} can be applied to any one of the pass transistors. GATE must be connected externally to V_{BIAS} .

Figure 3. Typical Application Circuit

APPLICATION INFORMATION

electrical characteristics

The electrical characteristics of the NMOS transistors used in the TVC devices are illustrated by TI SPICE simulations. Figure 4 shows the test configuration for the TI SPICE simulations. The results, shown in Figures 5 and 6, show the current through a pass transistor versus the voltage at the source for different reference voltages. The plots of the dc characteristics clearly reveal that the device clamps at the desired reference voltage for the varying device environments.

Figure 5 shows the V-I characteristics, with low reference voltages and a reference-transistor drain-supply voltage of 3.3 V. To further investigate the spread of the V-I characteristic curves, V_{REF} was held at 2.5 V and I_{REF} was increased by raising V_{DDREF} (see Figure 6). The result was a tighter grouping of the V-I curves.

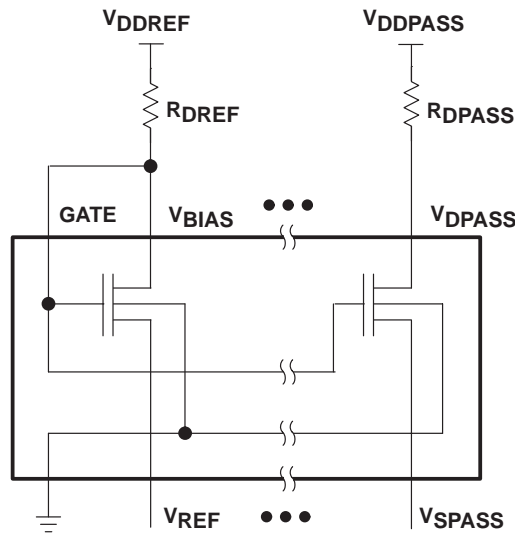

Figure 4. TI SPICE Simulation Schematic and Voltage-Node Names

SN74TVC3010 10-BIT VOLTAGE CLAMP

SCDS088G – APRIL 1999 – REVISED AUGUST 2003

APPLICATION INFORMATION

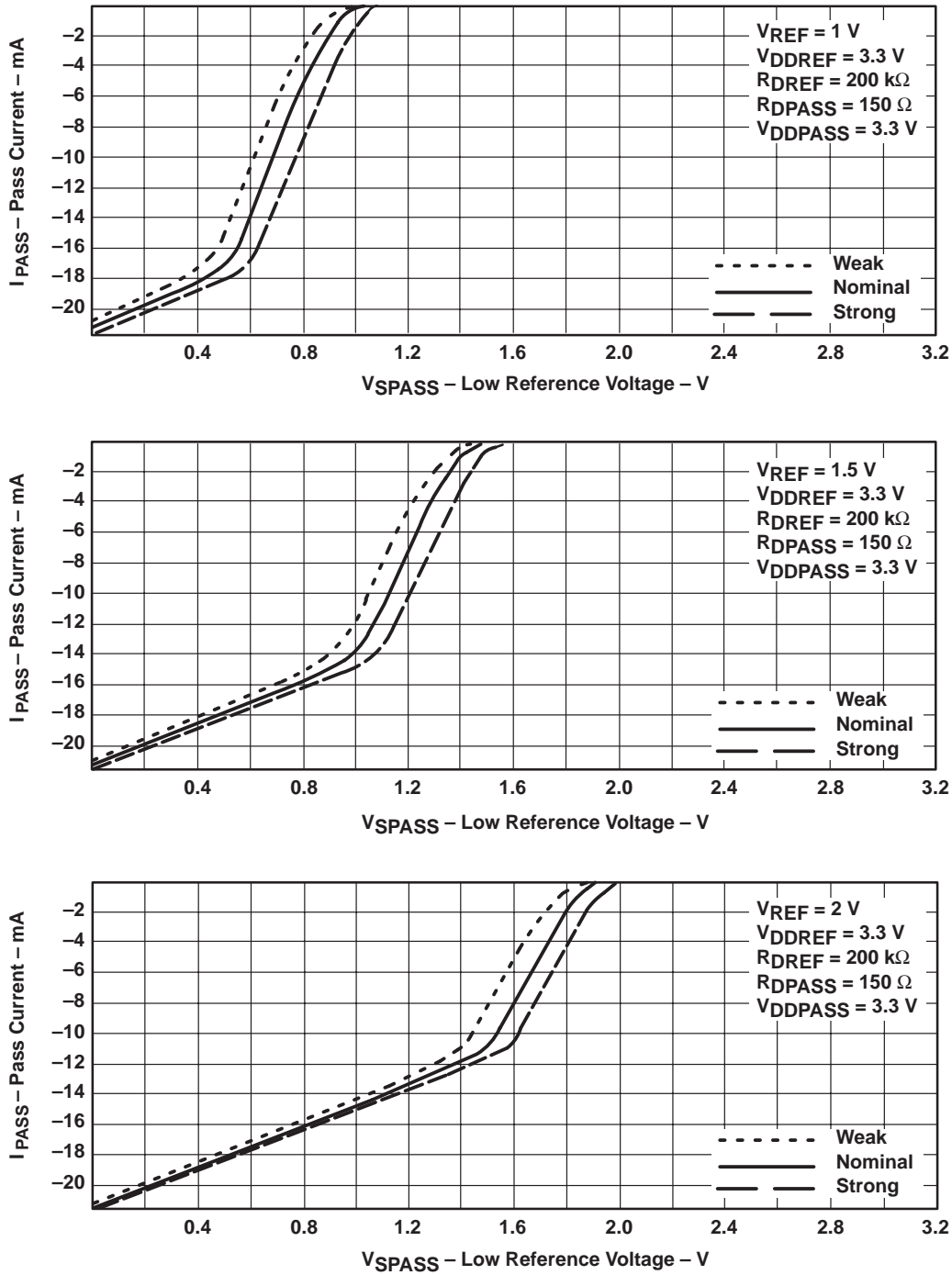

Figure 5. Electrical Characteristics at Low V_{REF} Voltages

APPLICATION INFORMATION

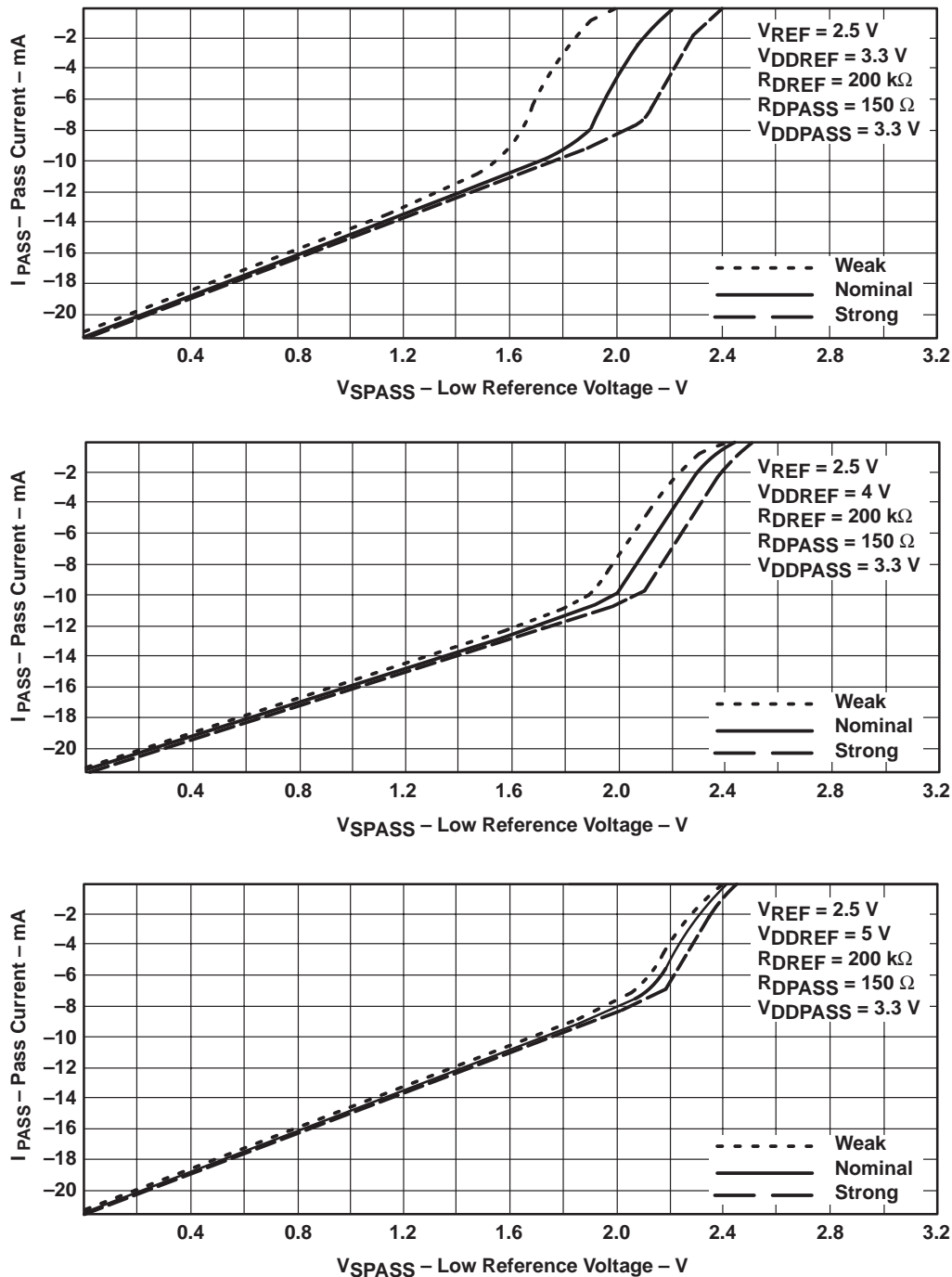

Figure 6. Electrical Characteristics at $V_{REF} = 2.5\text{ V}$

SN74TVC3010

10-BIT VOLTAGE CLAMP

SCDS088G – APRIL 1999 – REVISED AUGUST 2003

APPLICATION INFORMATION

features and benefits

The TVC family has several features that benefit a system designer when implementing a sensitive-I/O-protection solution. Table 1 lists these features and their associated benefits.

Table 1. Features and Benefits

FEATURES	BENEFITS
Any FET can be used as the reference transistor.	Ease of layout
All FETs on one die, tight process control	Very low spread of V_O relative to V_{REF}
No active control logic (passive device)	No logic power supply (V_{CC}) required
Flow-through pinout	Ease of trace routing
Devices offered in different bit-widths and packages	Optimizes design and cost effectiveness
Designer flexibility with V_{REF} input	Allows migration to lower-voltage I/Os without board redesign

conclusion

The TI TVC family provides the designer with a solution for protection of circuits with I/Os that are sensitive to high-state voltage-level overshoots. The flexibility of TVC enables a low-voltage migration path for advanced designs to align with industry standards.

frequently asked questions (FAQ)

- Q: Can any of the transistors in the array be used as the reference transistor?

A: Yes, any transistor can be used as long as its V_{BIAS} pin is connected to the GATE pin.
- Q: In the recommended operating conditions table of the data sheet, the typical V_{BIAS} is 3.3 V. Should V_{BIAS} be equal to or greater than V_{REF} on the reference transistor?

A: V_{BIAS} is a variable that is determined by V_{REF} . V_{BIAS} is connected to V_{DD} through a resistor to allow the bias voltage to be controlled by V_{REF} . V_{DD} can be as high as 5.5 V. V_{REF} needs to be at least 1 V less than V_{DDREF} on the reference transistor.
- Q: Do both A and B ports have 5-V I/O tolerance or is 5-V I/O tolerance provided only on the low-voltage side?

A: Both ports are 5-V tolerant.

PACKAGING INFORMATION

Orderable Device	Status (1)	Package Type	Package Drawing	Pins	Package Qty	Eco Plan (2)	Lead finish/ Ball material (6)	MSL Peak Temp (3)	Op Temp (°C)	Device Marking (4/5)	Samples
SN74TVC3010DBQR	NRND	SSOP	DBQ	24	2500	RoHS & Green	NIPDAU	Level-2-260C-1 YEAR	-40 to 85	TVC3010	
SN74TVC3010DGVR	NRND	TVSOP	DGV	24	2000	RoHS & Green	NIPDAU	Level-1-260C-UNLIM	-40 to 85	TT010	
SN74TVC3010DW	NRND	SOIC	DW	24	25	RoHS & Green	NIPDAU	Level-1-260C-UNLIM	-40 to 85	TVC3010	
SN74TVC3010DWR	NRND	SOIC	DW	24	2000	RoHS & Green	NIPDAU	Level-1-260C-UNLIM	-40 to 85	TVC3010	
SN74TVC3010PW	NRND	TSSOP	PW	24	60	RoHS & Green	NIPDAU	Level-1-260C-UNLIM	-40 to 85	TT010	
SN74TVC3010PWR	NRND	TSSOP	PW	24	2000	RoHS & Green	NIPDAU	Level-1-260C-UNLIM	-40 to 85	TT010	

(1) The marketing status values are defined as follows:

ACTIVE: Product device recommended for new designs.

LIFEBUY: TI has announced that the device will be discontinued, and a lifetime-buy period is in effect.

NRND: Not recommended for new designs. Device is in production to support existing customers, but TI does not recommend using this part in a new design.

PREVIEW: Device has been announced but is not in production. Samples may or may not be available.

OBSELETE: TI has discontinued the production of the device.

(2) **RoHS:** TI defines "RoHS" to mean semiconductor products that are compliant with the current EU RoHS requirements for all 10 RoHS substances, including the requirement that RoHS substance do not exceed 0.1% by weight in homogeneous materials. Where designed to be soldered at high temperatures, "RoHS" products are suitable for use in specified lead-free processes. TI may reference these types of products as "Pb-Free".

RoHS Exempt: TI defines "RoHS Exempt" to mean products that contain lead but are compliant with EU RoHS pursuant to a specific EU RoHS exemption.

Green: TI defines "Green" to mean the content of Chlorine (Cl) and Bromine (Br) based flame retardants meet JS709B low halogen requirements of <=1000ppm threshold. Antimony trioxide based flame retardants must also meet the <=1000ppm threshold requirement.

(3) MSL, Peak Temp. - The Moisture Sensitivity Level rating according to the JEDEC industry standard classifications, and peak solder temperature.

(4) There may be additional marking, which relates to the logo, the lot trace code information, or the environmental category on the device.

(5) Multiple Device Markings will be inside parentheses. Only one Device Marking contained in parentheses and separated by a "~" will appear on a device. If a line is indented then it is a continuation of the previous line and the two combined represent the entire Device Marking for that device.

(6) Lead finish/Ball material - Orderable Devices may have multiple material finish options. Finish options are separated by a vertical ruled line. Lead finish/Ball material values may wrap to two lines if the finish value exceeds the maximum column width.

Important Information and Disclaimer:The information provided on this page represents TI's knowledge and belief as of the date that it is provided. TI bases its knowledge and belief on information provided by third parties, and makes no representation or warranty as to the accuracy of such information. Efforts are underway to better integrate information from third parties. TI has taken and

continues to take reasonable steps to provide representative and accurate information but may not have conducted destructive testing or chemical analysis on incoming materials and chemicals. TI and TI suppliers consider certain information to be proprietary, and thus CAS numbers and other limited information may not be available for release.

In no event shall TI's liability arising out of such information exceed the total purchase price of the TI part(s) at issue in this document sold by TI to Customer on an annual basis.

TAPE AND REEL INFORMATION

QUADRANT ASSIGNMENTS FOR PIN 1 ORIENTATION IN TAPE

*All dimensions are nominal

Device	Package Type	Package Drawing	Pins	SPQ	Reel Diameter (mm)	Reel Width W1 (mm)	A0 (mm)	B0 (mm)	K0 (mm)	P1 (mm)	W (mm)	Pin1 Quadrant
SN74TVC3010DBQR	SSOP	DBQ	24	2500	330.0	16.4	6.5	9.0	2.1	8.0	16.0	Q1
SN74TVC3010DGVR	TVSOP	DGV	24	2000	330.0	12.4	6.9	5.6	1.6	8.0	12.0	Q1
SN74TVC3010DWR	SOIC	DW	24	2000	330.0	24.4	10.75	15.7	2.7	12.0	24.0	Q1
SN74TVC3010PWR	TSSOP	PW	24	2000	330.0	16.4	6.95	8.3	1.6	8.0	16.0	Q1

TAPE AND REEL BOX DIMENSIONS



*All dimensions are nominal

Device	Package Type	Package Drawing	Pins	SPQ	Length (mm)	Width (mm)	Height (mm)
SN74TVC3010DBQR	SSOP	DBQ	24	2500	356.0	356.0	35.0
SN74TVC3010DGVR	TVSOP	DGV	24	2000	356.0	356.0	35.0
SN74TVC3010DWR	SOIC	DW	24	2000	350.0	350.0	43.0
SN74TVC3010PWR	TSSOP	PW	24	2000	356.0	356.0	35.0

TUBE

*All dimensions are nominal

Device	Package Name	Package Type	Pins	SPQ	L (mm)	W (mm)	T (μm)	B (mm)
SN74TVC3010DW	DW	SOIC	24	25	506.98	12.7	4826	6.6
SN74TVC3010PW	PW	TSSOP	24	60	530	10.2	3600	3.5

PW0024A

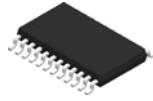

PACKAGE OUTLINE

TSSOP - 1.2 mm max height

SMALL OUTLINE PACKAGE

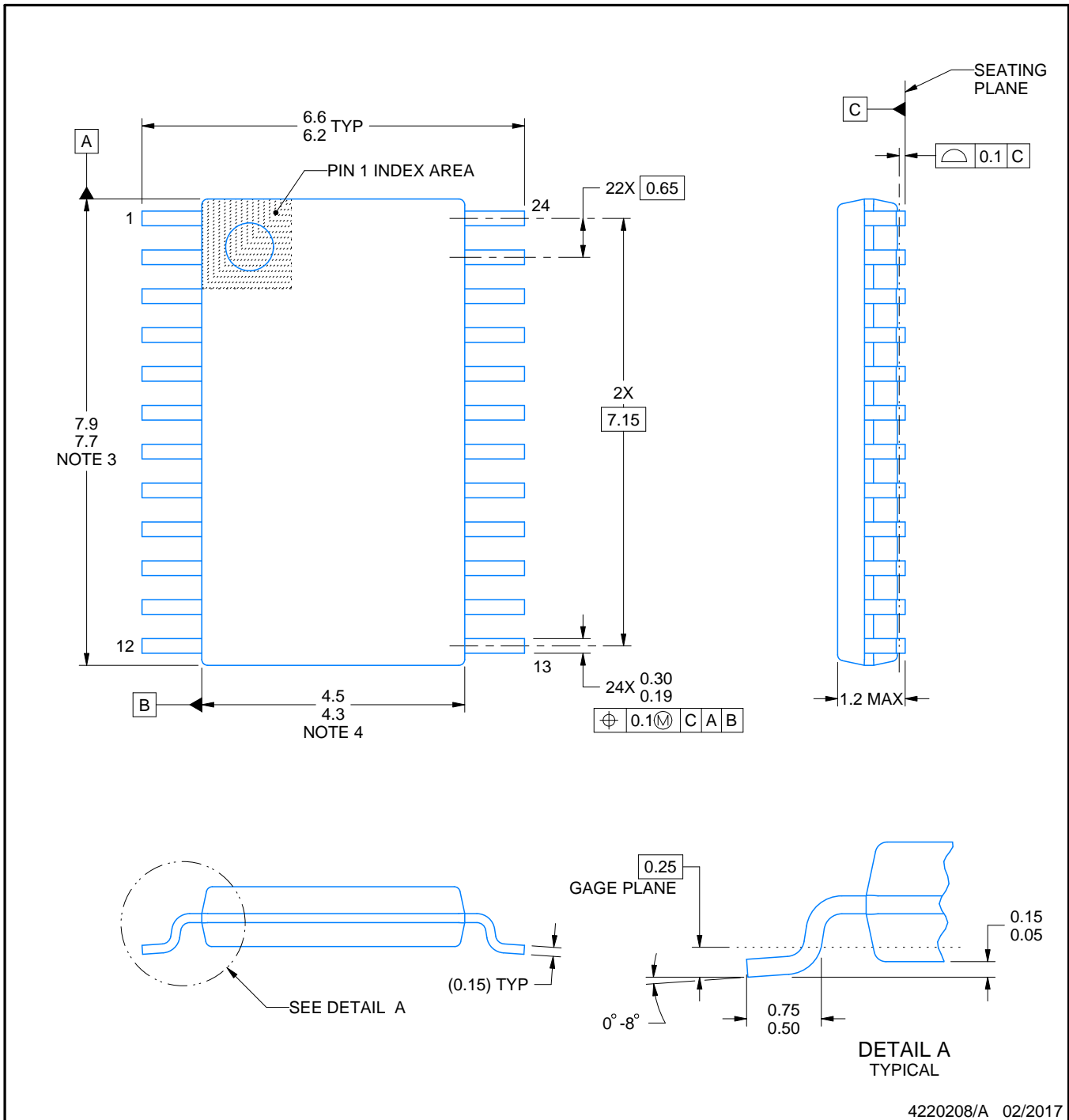

4220208/A 02/2017

NOTES:

1. All linear dimensions are in millimeters. Any dimensions in parenthesis are for reference only. Dimensioning and tolerancing per ASME Y14.5M.
2. This drawing is subject to change without notice.
3. This dimension does not include mold flash, protrusions, or gate burrs. Mold flash, protrusions, or gate burrs shall not exceed 0.15 mm per side.
4. This dimension does not include interlead flash. Interlead flash shall not exceed 0.25 mm per side.
5. Reference JEDEC registration MO-153.

EXAMPLE BOARD LAYOUT

PW0024A

TSSOP - 1.2 mm max height

SMALL OUTLINE PACKAGE

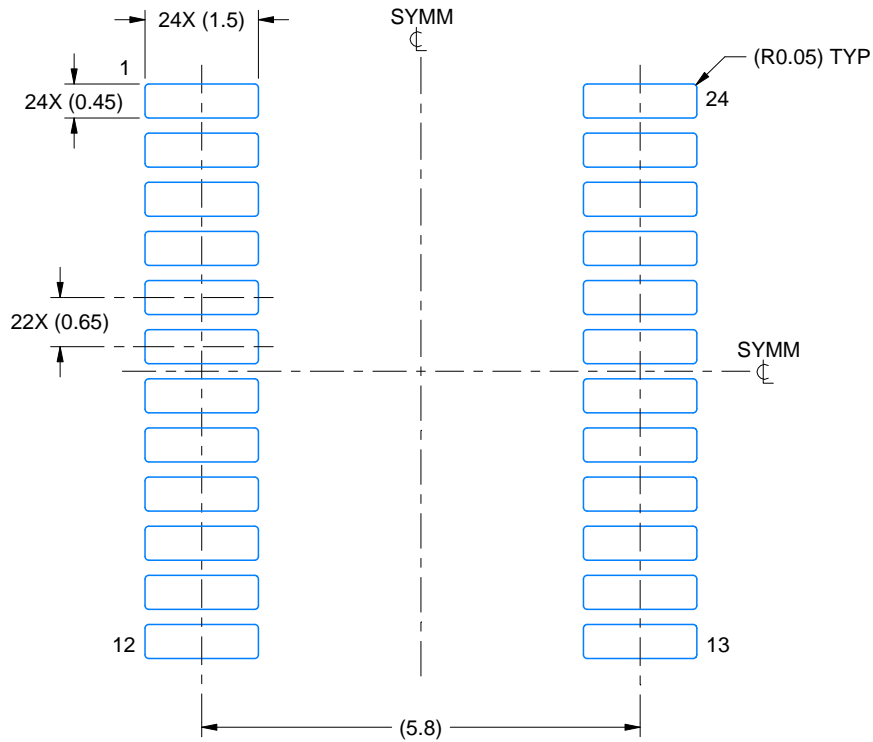

LAND PATTERN EXAMPLE
EXPOSED METAL SHOWN
SCALE: 10X

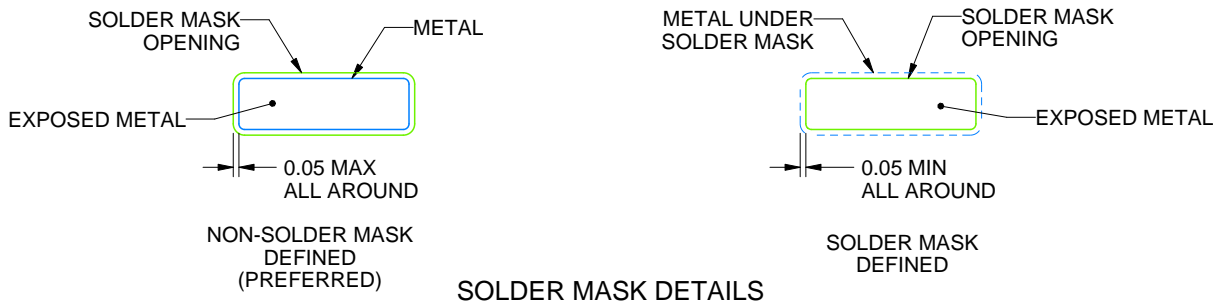

SOLDER MASK DETAILS

4220208/A 02/2017

NOTES: (continued)

- 6. Publication IPC-7351 may have alternate designs.
- 7. Solder mask tolerances between and around signal pads can vary based on board fabrication site.

EXAMPLE STENCIL DESIGN

PW0024A

TSSOP - 1.2 mm max height

SMALL OUTLINE PACKAGE

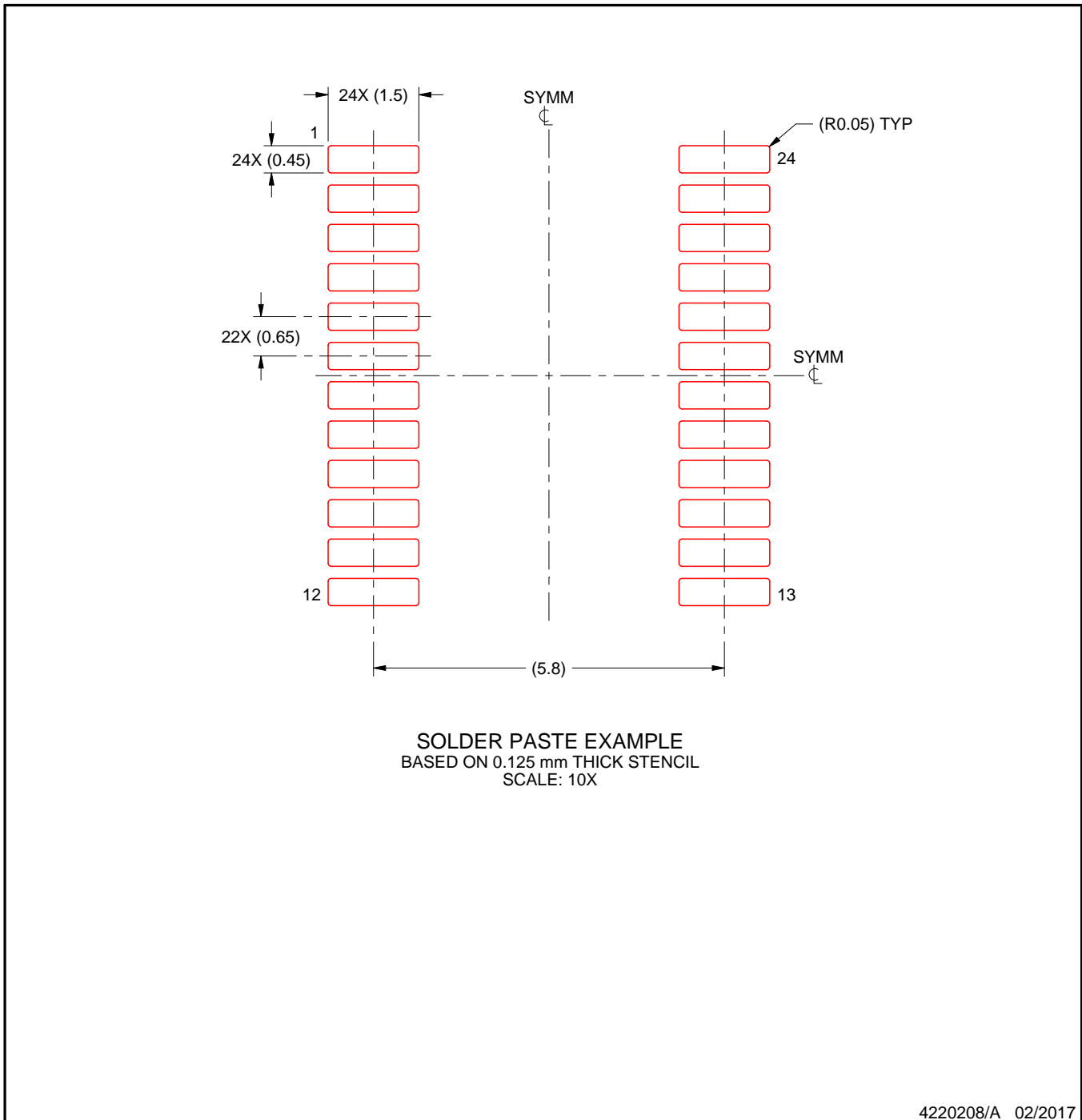

NOTES: (continued)

8. Laser cutting apertures with trapezoidal walls and rounded corners may offer better paste release. IPC-7525 may have alternate design recommendations.
9. Board assembly site may have different recommendations for stencil design.

DGV (R-PDSO-G**)

PLASTIC SMALL-OUTLINE

24 PINS SHOWN



- NOTES: A. All linear dimensions are in millimeters.
 B. This drawing is subject to change without notice.
 C. Body dimensions do not include mold flash or protrusion, not to exceed 0,15 per side.
 D. Falls within JEDEC: 24/48 Pins – MO-153
 14/16/20/56 Pins – MO-194

DW (R-PDSO-G24)

PLASTIC SMALL OUTLINE

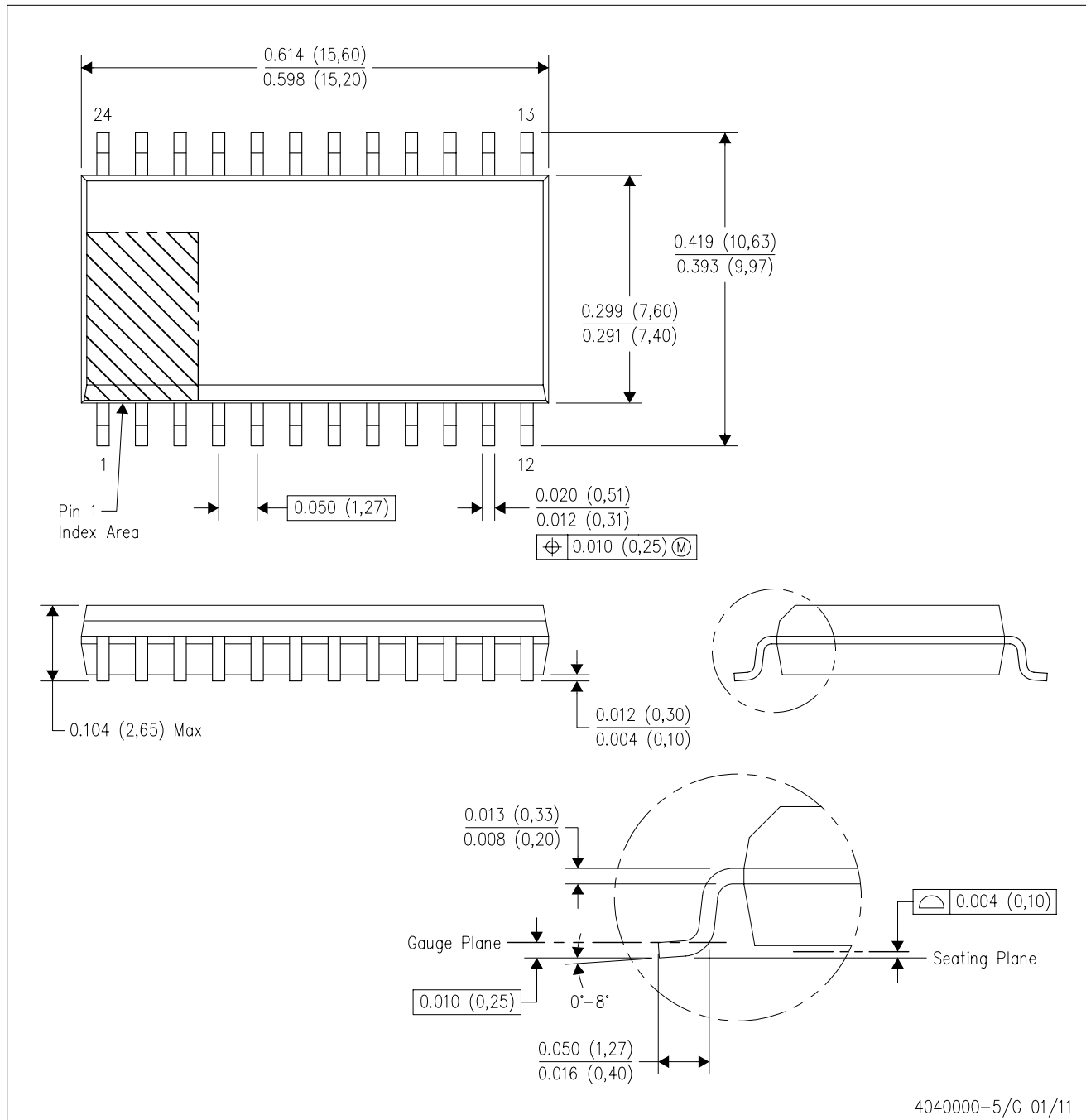

- NOTES:
- A. All linear dimensions are in inches (millimeters). Dimensioning and tolerancing per ASME Y14.5M-1994.
 - B. This drawing is subject to change without notice.
 - C. Body dimensions do not include mold flash or protrusion not to exceed 0.006 (0,15).
 - D. Falls within JEDEC MS-013 variation AD.

IMPORTANT NOTICE AND DISCLAIMER

TI PROVIDES TECHNICAL AND RELIABILITY DATA (INCLUDING DATA SHEETS), DESIGN RESOURCES (INCLUDING REFERENCE DESIGNS), APPLICATION OR OTHER DESIGN ADVICE, WEB TOOLS, SAFETY INFORMATION, AND OTHER RESOURCES "AS IS" AND WITH ALL FAULTS, AND DISCLAIMS ALL WARRANTIES, EXPRESS AND IMPLIED, INCLUDING WITHOUT LIMITATION ANY IMPLIED WARRANTIES OF MERCHANTABILITY, FITNESS FOR A PARTICULAR PURPOSE OR NON-INFRINGEMENT OF THIRD PARTY INTELLECTUAL PROPERTY RIGHTS.

These resources are intended for skilled developers designing with TI products. You are solely responsible for (1) selecting the appropriate TI products for your application, (2) designing, validating and testing your application, and (3) ensuring your application meets applicable standards, and any other safety, security, regulatory or other requirements.

These resources are subject to change without notice. TI grants you permission to use these resources only for development of an application that uses the TI products described in the resource. Other reproduction and display of these resources is prohibited. No license is granted to any other TI intellectual property right or to any third party intellectual property right. TI disclaims responsibility for, and you will fully indemnify TI and its representatives against, any claims, damages, costs, losses, and liabilities arising out of your use of these resources.

TI's products are provided subject to [TI's Terms of Sale](#) or other applicable terms available either on [ti.com](https://www.ti.com) or provided in conjunction with such TI products. TI's provision of these resources does not expand or otherwise alter TI's applicable warranties or warranty disclaimers for TI products.

TI objects to and rejects any additional or different terms you may have proposed.

Mailing Address: Texas Instruments, Post Office Box 655303, Dallas, Texas 75265
Copyright © 2024, Texas Instruments Incorporated

Looking for pricing, stock, or lifecycle information?

Click below to explore more details on WIN SOURCE:

 [View SN74TVC3010DW on WIN SOURCE](#)

 [Texas Instruments](#) Information

Optimize Your Supply Chain with WIN SOURCE Solutions

-  Global Sourcing Solution
-  Obsolete Management
-  Cost Control Management
-  Shortage Management
-  Alternative Solution
-  Excess Inventory Management