



**THE DATASHEET OF
UC385TDKTTT-1G3**





- Fast Transient Response
- 10-mA to 5-A Load Current
- Short Circuit Protection
- Maximum Dropout of 500-mV at 5-A Load Current
- Separate Bias (VB) and VIN Pins
- Available in Adjustable or Fixed Output Voltages
- 5-Pin Package Allows Kelvin Sensing of Load Voltage
- Reverse Current Protection

5-PIN TO-220
T PACKAGE (TOP VIEW)

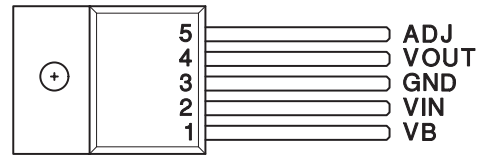

5-PIN TO-263
TD PACKAGE
(TOP VIEW)

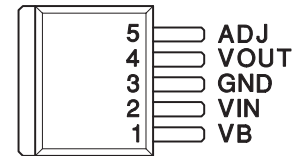

Note: Tab = Ground

description

The UC385 is a low dropout linear regulator providing a quick response to fast load changes. Combined with its precision onboard reference, the UC385 excels at driving GTL and BTL buses. Due to its fast response to load transients, the total capacitance required to decouple the regulator's output can be significantly decreased when compared to standard LDO linear regulators.

Dropout voltage (VIN to VOUT) is only 490 mV maximum and 350 mV typical at 5-A load (0°C to 100°C).

The onboard bandgap reference is stable with temperature and scaled for a 1.2 V input to the internal power amplifier. The UC385 is available in fixed output voltages of 1.5 V, 2.1 V, or 2.5 V. The output voltage of the adjustable version can be set with two external resistors. If the external resistors are omitted, the output voltage defaults to 1.2 V.

block diagram

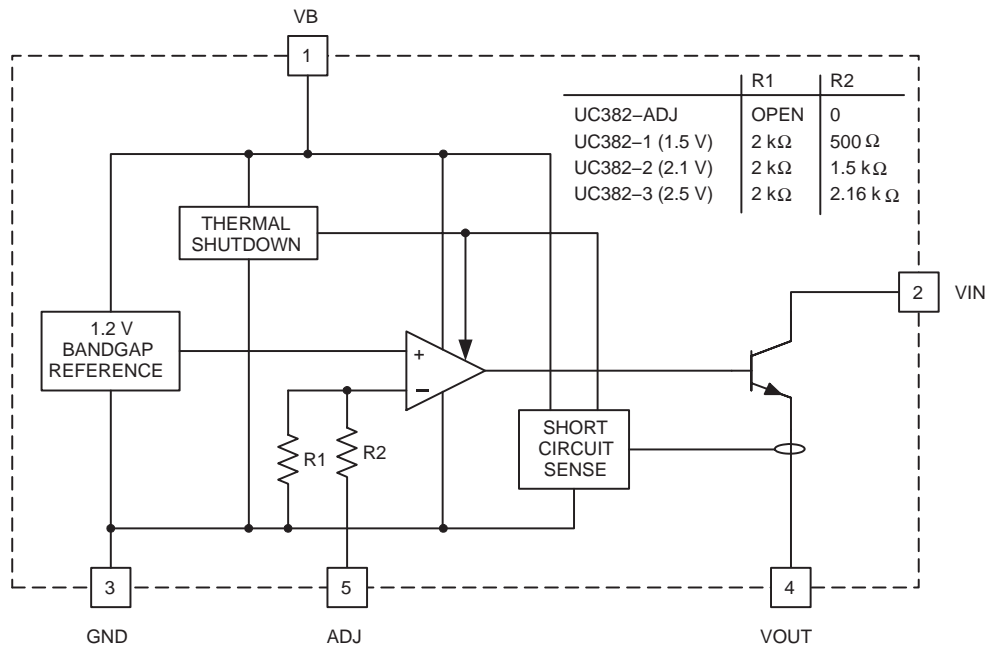

UDG-00084

Please be aware that an important notice concerning availability, standard warranty, and use in critical applications of Texas Instruments semiconductor products and disclaimers thereto appears at the end of this data sheet.



All trademarks are the property of their respective owners.

PRODUCTION DATA information is current as of publication date. Products conform to specifications per the terms of Texas Instruments standard warranty. Production processing does not necessarily include testing of all parameters.



www.ti.com

Copyright © 1998–2009, Texas Instruments Incorporated

UC285-1, UC285-2, UC285-3, UC285-ADJ, UC385-1, UC385-2, UC385-3, UC385-ADJ

FAST TRANSIENT RESPONSE 5-A

LOW-DROPOUT REGULATOR

SLUS212F – NOVEMBER 1999 – REVISED MAY 2009

absolute maximum ratings over operating free-air temperature (unless otherwise noted)†

VB	13 V
VIN	7.5 V
Output voltage	1.2 V to –6.0 V
Storage temperature	–65°C to 150°C
Junction temperature	–55°C to 150°C
Lead temperature (soldering, 10 seconds)	300°C

† Stresses beyond those listed under “absolute maximum ratings” may cause permanent damage to the device. These are stress ratings only, and functional operation of the device at these or any other conditions beyond those indicated under “recommended operating conditions” is not implied. Exposure to absolute-maximum-rated conditions for extended periods may affect device reliability.

AVAILABLE OPTIONS(1)

T _J	PACKAGED DEVICES							
	TO-220 (T)				TO-263 (TD)(2)			
	OUTPUT VOLTAGE				OUTPUT VOLTAGE			
	1.5 V	2.1 V	2.5 V	1.2 V or ADJ	1.5 V	2.1 V	2.5 V	1.2 V or ADJ
–40°C to 100°C	285T-1	285T-2	285T-3	285T-ADJ	285TD-1	285TD-2	285TD-3	285TD-ADJ
0°C to 100°C	385T-1	385T-2	385T-3	385T-ADJ	385TD-1	385TD-2	385TD-3	385TD-ADJ

- For more package and ordering information, see the Package Option Addendum located at the end of this data sheet.
- For 50 piece reel, add KTTT (e.g., UC285TDKTTT-1); for 500 piece reel, add TR (e.g., UC285TDTR-1).

electrical characteristics unless otherwise stated, these parameters apply for T_A = –40°C to 100°C for the UC285-x series and 0°C to 100°C for the UC385-x, V_B = 5 V; V_{IN} = 3.3 V, V_{OUT} = 2.5 V, T_A = T_J.

PARAMETER	TEST CONDITION		MIN	TYP	MAX	UNIT
UC385-3 Fixed 2.5 V, 5-A Family						
Output voltage	UC385-3	I _{VOUT} = 100 mA	2.475	2.5	2.525	V
	UC285-3	I _{VOUT} = 100 mA	2.45	2.5	2.525	V
Load regulation	I _{VOUT} = 10 mA to 5 A			0.5	4	mV
VIN PSRR			80	110		dB
VB PSRR			50	65		dB
VIN dropout voltage (VIN - VOUT)	I _{VOUT} = 5 A, T _J = 25°C			350	425	mV
	UC385-3	I _{VOUT} = 5 A		350	490	mV
	UC285-3	I _{VOUT} = 5 A		350	500	mV
VB dropout (VB - VOUT)	UC385-3	I _{VOUT} = 5 A		1.8	2.1	V
	UC285-3	I _{VOUT} = 5 A		1.8	2.2	V
Short circuit current limit			5.1		7.5	A
VB current	I _{VOUT} = 10 mA			8	15	mA
	I _{VOUT} = 5 A			40	100	mA
VIN current	I _{VOUT} = 5 A		4.9	4.96		A
UC385-2 Fixed 2.1 V, 5-A Family						
Output voltage	UC385-2	I _{VOUT} = 100 mA	2.079	2.1	2.121	V
	UC285-2	I _{VOUT} = 100 mA	2.058	2.1	2.121	V
Load regulation	I _{VOUT} = 10 mA to 5 A			0.5	4	mV
VIN PSRR			80	110		dB
VB PSRR			50	67		dB

UC285-1, UC285-2, UC285-3, UC285-ADJ, UC385-1, UC385-2, UC385-3, UC385-ADJ FAST TRANSIENT RESPONSE 5-A LOW-DROPOUT REGULATOR

SLUS212F – NOVEMBER 1999 – REVISED MAY 2009

electrical characteristics unless otherwise stated, these parameters apply for $T_A = -40^\circ\text{C}$ to 100°C for the UC285-x series and 0°C to 100°C for the UC385-x, $V_B = 5\text{ V}$; $V_{IN} = 3.3\text{ V}$, $V_{OUT} = 2.5\text{ V}$, $T_A = T_J$.

PARAMETER		TEST CONDITION	MIN	TYP	MAX	UNIT
UC385-2 Fixed 2.1 V, 5-A Family (continued)						
VIN dropout voltage (VIN - VOUT)		I _{VOUT} = 5 A, T _J = 25°C		350	425	mV
	UC385-2	I _{VOUT} = 5 A		350	490	mV
	UC285-2	I _{VOUT} = 5 A		350	500	mV
VB dropout (VB - VOUT)	UC385-2	I _{VOUT} = 5 A		1.8	2.1	V
	UC285-2	I _{VOUT} = 5 A		1.8	2.2	V
Short circuit current limit			5.1		7.5	A
VB current	I _{VOUT} = 10 mA			8	15	mA
	I _{VOUT} = 5 A			40	100	mA
VIN current		I _{VOUT} = 5 A	4.9	4.96		A
UC385-1 Fixed 1.5 V, 5-A Family						
Output voltage	UC385-1	I _{VOUT} = 100 mA	1.485	1.5	1.515	V
	UC285-1	I _{VOUT} = 100 mA	1.470	1.5	1.515	V
Load regulation		I _{VOUT} = 10 mA to 5 A		0.5	4	mV
VIN PSRR			80	110		dB
VB PSRR			50	65		dB
VIN dropout voltage (VIN - VOUT)		I _{VOUT} = 5 A, T _J = 25°C		350	425	mV
	UC285-1	I _{VOUT} = 5 A		350	490	mV
	UC285-2	I _{VOUT} = 5 A		350	500	mV
VB dropout (VB - VOUT)	UC385-1	I _{VOUT} = 5 A		1.8	2.1	V
	UC285-1	I _{VOUT} = 5 A		1.8	2.2	V
Short circuit current limit			5.1		7.5	A
VB current	I _{VOUT} = 10 mA			8	15	mA
	I _{VOUT} = 5 A			40	100	mA
VIN = current		I _{VOUT} = 5 A	4.9	4.96		A
UC385-ADJ Adjustable, 5-A Family						
ADJ voltage	UC385-ADJ	I _{VOUT} = 100 mA	1.188	1.2	1.212	V
	UC285-ADJ	I _{VOUT} = 100 mA	1.176	1.2	1.212	V
Load regulation		I _{VOUT} = 10 mA to 5 A		0.5	4	mV
VIN PSRR		V _{OUT} programmed for 2.5 V	80	110		dB
VB PSRR V _{OUT}		Programmed for 2.5 V	50	65		dB
VIN dropout voltage (VIN - VOUT)		I _{VOUT} = 5 A, T _J = 25°C		350	425	mV
	UC385-ADJ	I _{VOUT} = 5 A		350	490	mV
	UC285-ADJ	I _{VOUT} = 5 A		350	500	mV
VB dropout (VB - VOUT)	UC385-ADJ	I _{VOUT} = 5 A		1.8	2.1	V
	UC285-ADJ	I _{VOUT} = 5 A		1.8	2.2	V
Short circuit current limit			5.1		7.5	A
VB current	I _{VOUT} = 10 mA			8	15	mA
	I _{VOUT} = 5 A			40	100	mA
VIN current		I _{VOUT} = 5 A	4.9	4.96		A

UC285-1, UC285-2, UC285-3, UC285-ADJ, UC385-1, UC385-2, UC385-3, UC385-ADJ

FAST TRANSIENT RESPONSE 5-A

LOW-DROPOUT REGULATOR

SLUS212F – NOVEMBER 1999 – REVISED MAY 2009

pin descriptions

ADJ: In the adjustable version, the user programs the output voltage with two external resistors. The resistors should be 0.1% for high accuracy. The output amplifier is configured as a noninverting operational amplifier. The resistors should meet the criteria of $R3 \parallel R4 < 100 \Omega$. Connect ADJ to VOUT for an output voltage of 1.2 V. Note that the point at which the feedback network is connected to the output is the Kelvin sense point.

GND: For accurate results, the GND pin should be referenced to the load ground.

VB: Supplies power to all circuits of the regulator except the output power transistor. The 2-V headroom from VB to VOUT allows the use of a Darlington output stage for inherently low output impedance and fast response. (Dropout is derated for junction temperatures below 0°C.)

VIN: Supplies the current to the collector of the output power transistor only. The dropout ($V_{IN}-V_{OUT}$) is under 100 mV for light loads; maximum dropout is 490 mV at 5 A for $T_J = 0^\circ\text{C}$ to 100°C . (Dropout is derated for junction temperatures over 100°C .)

VOUT: This pin should be connected to the load via a low impedance path. Avoid connectors which add significant inductance and resistance. Note that even though a Kelvin sense is available through a 5-pin package, care must be taken since voltage drops along wire traces add to the dropout voltage.

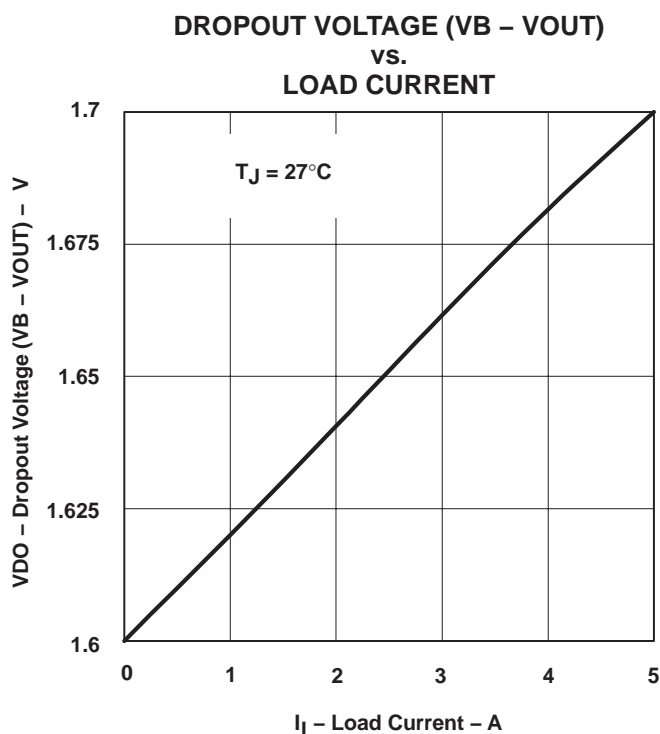

Figure 1

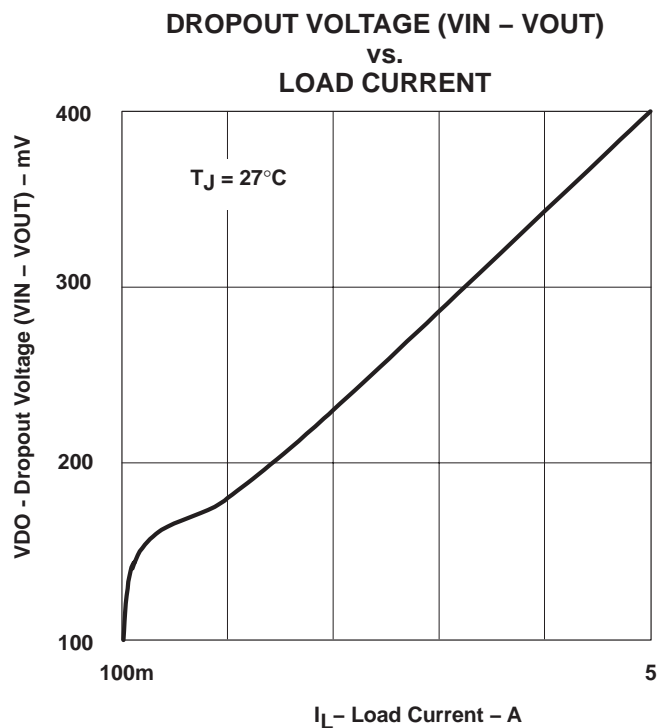

Figure 2

APPLICATION INFORMATION

The UC385 is easy to use. The adjustable version requires two resistors to set the output voltage. The fixed versions of the UC385 require no external resistors. All versions of the UC385 require decoupling capacitors on the input and output. In a typical application, V_B and V_{IN} are driven from switching power supplies which may have large filter capacitors at their outputs. If the UC385 is further than 12 inches from the power supply, it is recommended to add local decoupling as close as possible to the linear regulator.

Decouple the output of the UC385 with at least 100 μF of high quality tantalum or Sanyo OSCON capacitors close to the V_{OUT} pin for maximum stability. Many applications involving ultrafast GTL or BTL applications require additional capacitance close to the load. The exact amount will vary according to speed and magnitude of the load transients and the tolerance allowed for transients on V_{OUT} . When specifying the decoupling capacitors, the series resistance of the capacitor bank is an important factor in its ability to filter load transients.

The UC385 allows for Kelvin sensing the voltage at the load. This improves regulation performance and eliminates the voltage drops due to wire trace resistance. This voltage drop must be added to the headroom (V_{IN} to V_{OUT} and V_B to V_{OUT}). The dropout of 350 mV is measured at the pins and does not include additional drops due to trace resistance.

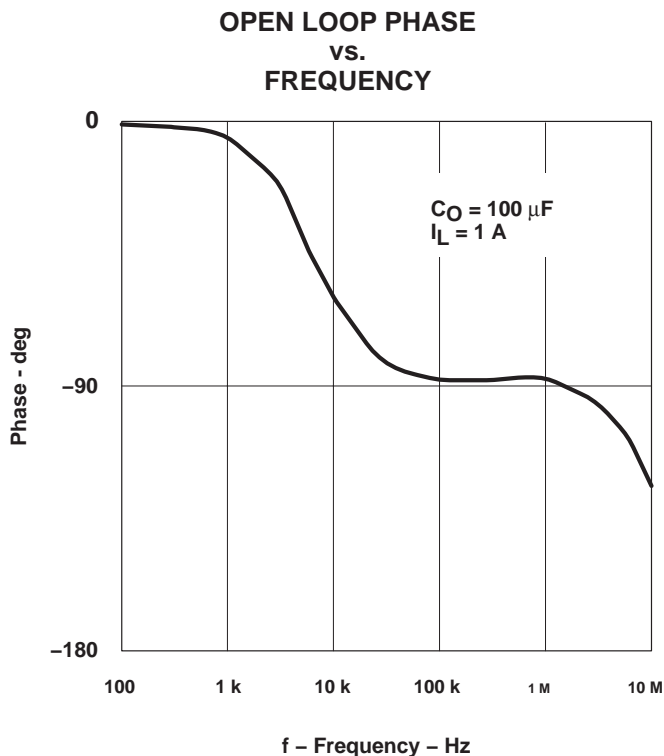

Figure 3

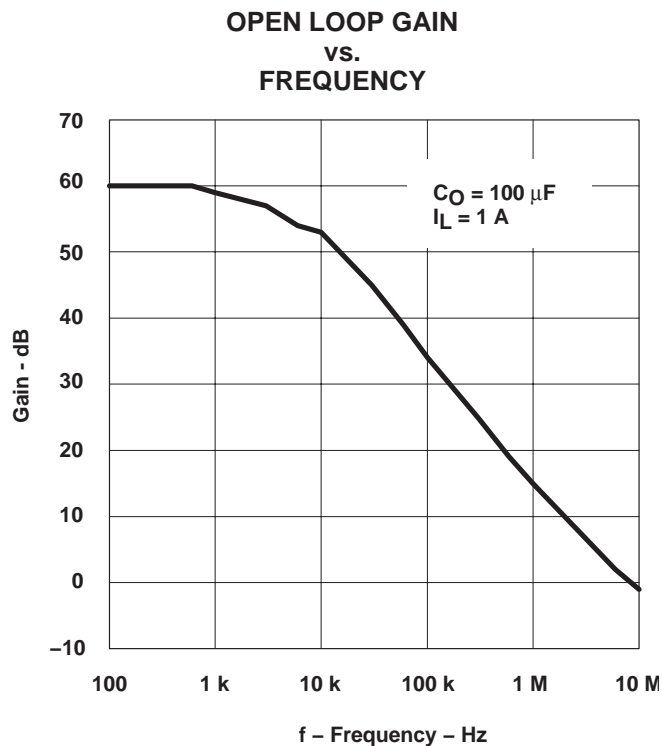

Figure 4

UC285-1, UC285-2, UC285-3, UC285-ADJ, UC385-1, UC385-2, UC385-3, UC385-ADJ
FAST TRANSIENT RESPONSE 5-A
LOW-DROPOUT REGULATOR

SLUS212F – NOVEMBER 1999 – REVISED MAY 2009

APPLICATION INFORMATION

**POWER SUPPLY REJECTION RATIO (VB INPUT)
 vs.
 FREQUENCY**

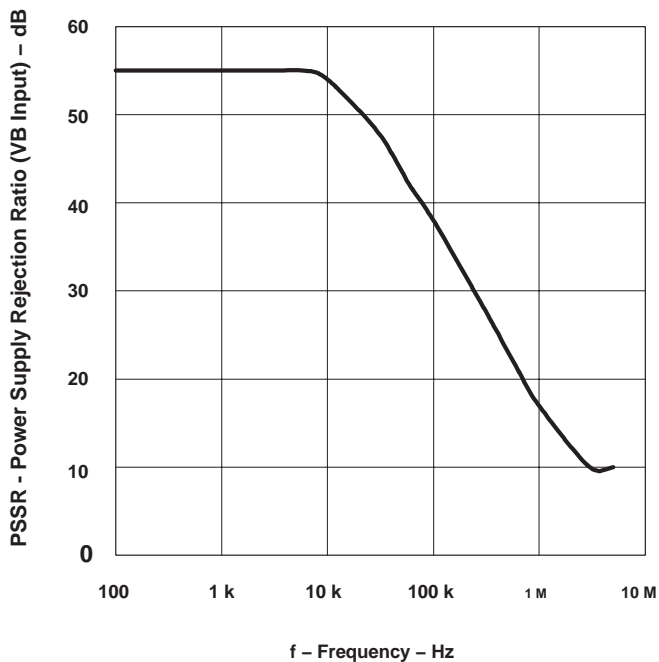
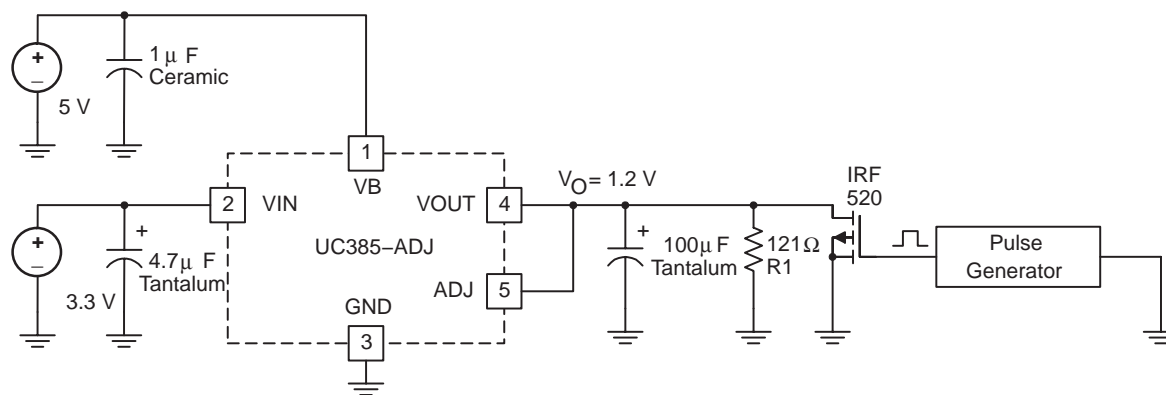

Figure 5



UDG-00085

Figure 6. Transient Test Circuit

APPLICATION INFORMATION

10 mA to 3 A/ μ s Load Transient Response

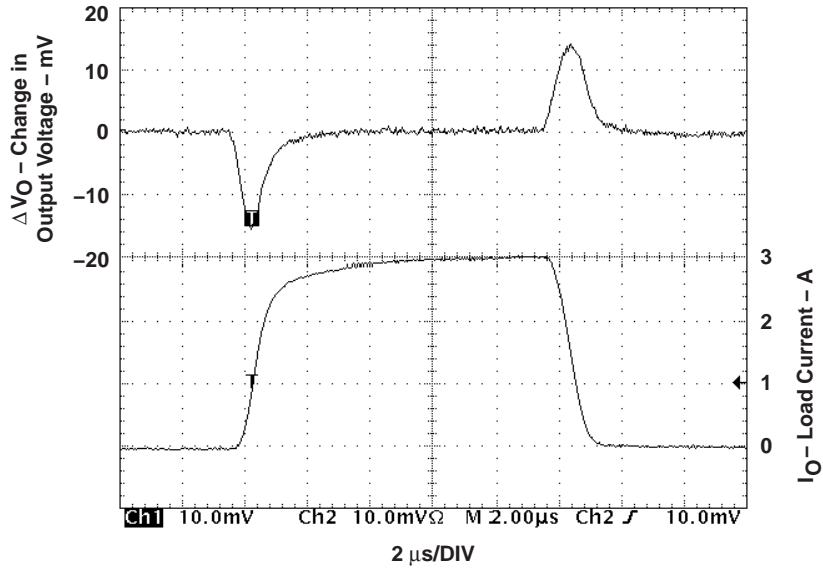
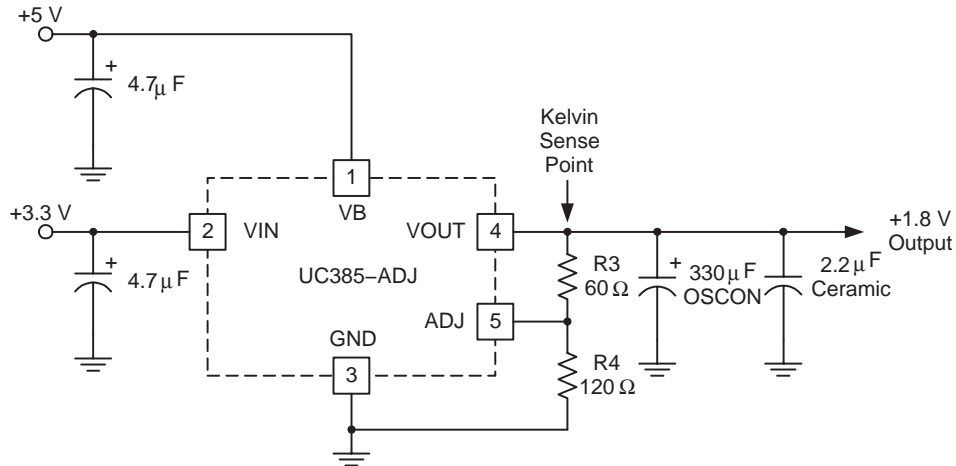

Figure 7



UDG-00086

Figure 8. Typical UC385-ADJ Application

UC285-1, UC285-2, UC285-3, UC285-ADJ, UC385-1, UC385-2, UC385-3, UC385-ADJ

FAST TRANSIENT RESPONSE 5-A

LOW-DROPOUT REGULATOR

SLUS212F – NOVEMBER 1999 – REVISED MAY 2009

APPLICATION INFORMATION

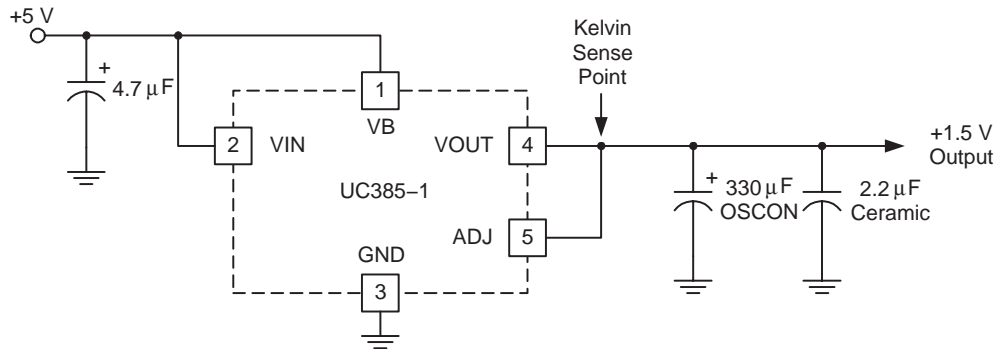

UDG-00087

Figure 9. Typical UC385-1, -2, or -3 Application

Revision History

DATE	REV	PAGE	SECTION	DESCRIPTION
5/09	F	2	Absolute Maximum Ratings	Added VB.

NOTE: Page numbers for previous revisions may differ from page numbers in the current version.

PACKAGING INFORMATION

Orderable Device	Status ⁽¹⁾	Package Type	Package Drawing	Pins	Package Qty	Eco Plan ⁽²⁾	Lead/Ball Finish	MSL Peak Temp ⁽³⁾
UC285T-1	ACTIVE	TO-220	KC	5	50	Green (RoHS & no Sb/Br)	CU SN	N / A for Pkg Type
UC285T-1G3	ACTIVE	TO-220	KC	5	50	Green (RoHS & no Sb/Br)	CU SN	N / A for Pkg Type
UC285T-3	ACTIVE	TO-220	KC	5	50	Green (RoHS & no Sb/Br)	CU SN	N / A for Pkg Type
UC285T-3G3	ACTIVE	TO-220	KC	5	50	Green (RoHS & no Sb/Br)	CU SN	N / A for Pkg Type
UC285T-ADJ	ACTIVE	TO-220	KC	5	50	Green (RoHS & no Sb/Br)	CU SN	N / A for Pkg Type
UC285T-ADJG3	ACTIVE	TO-220	KC	5	50	Green (RoHS & no Sb/Br)	CU SN	N / A for Pkg Type
UC285TD-1	OBSOLETE	DDPAK/ TO-263	KTT	5		TBD	Call TI	Call TI
UC285TD-2	OBSOLETE	DDPAK/ TO-263	KTT	5		TBD	Call TI	Call TI
UC285TD-3	OBSOLETE	DDPAK/ TO-263	KTT	5		TBD	Call TI	Call TI
UC285TD-ADJ	OBSOLETE	DDPAK/ TO-263	KTT	5		TBD	Call TI	Call TI
UC285TDKTTT-1	ACTIVE	DDPAK/ TO-263	KTT	5	50	Green (RoHS & no Sb/Br)	CU SN	Level-2-260C-1 YEAR
UC285TDKTTT-1G3	ACTIVE	DDPAK/ TO-263	KTT	5	50	Green (RoHS & no Sb/Br)	CU SN	Level-2-260C-1 YEAR
UC285TDKTTT-3	ACTIVE	DDPAK/ TO-263	KTT	5	50	Green (RoHS & no Sb/Br)	CU SN	Level-2-260C-1 YEAR
UC285TDKTTT-3G3	ACTIVE	DDPAK/ TO-263	KTT	5	50	Green (RoHS & no Sb/Br)	CU SN	Level-2-260C-1 YEAR
UC285TDKTTT-ADJ	ACTIVE	DDPAK/ TO-263	KTT	5	50	Green (RoHS & no Sb/Br)	CU SN	Level-2-260C-1 YEAR
UC285TDKTTT-ADJG3	ACTIVE	DDPAK/ TO-263	KTT	5	50	Green (RoHS & no Sb/Br)	CU SN	Level-2-260C-1 YEAR
UC385T-1	ACTIVE	TO-220	KC	5	50	Green (RoHS & no Sb/Br)	CU SN	N / A for Pkg Type
UC385T-1G3	ACTIVE	TO-220	KC	5	50	Green (RoHS & no Sb/Br)	CU SN	N / A for Pkg Type
UC385T-2	ACTIVE	TO-220	KC	5	50	Green (RoHS & no Sb/Br)	CU SN	N / A for Pkg Type
UC385T-2G3	ACTIVE	TO-220	KC	5	50	Green (RoHS & no Sb/Br)	CU SN	N / A for Pkg Type
UC385T-3	ACTIVE	TO-220	KC	5	50	Green (RoHS & no Sb/Br)	CU SN	N / A for Pkg Type
UC385T-3G3	ACTIVE	TO-220	KC	5	50	Green (RoHS & no Sb/Br)	CU SN	N / A for Pkg Type
UC385T-ADJ	ACTIVE	TO-220	KC	5	50	Green (RoHS & no Sb/Br)	CU SN	N / A for Pkg Type
UC385T-ADJG3	ACTIVE	TO-220	KC	5	50	Green (RoHS & no Sb/Br)	CU SN	N / A for Pkg Type
UC385TD-1	OBSOLETE	DDPAK/ TO-263	KTT	5		TBD	Call TI	Call TI

Orderable Device	Status ⁽¹⁾	Package Type	Package Drawing	Pins	Package Qty	Eco Plan ⁽²⁾	Lead/Ball Finish	MSL Peak Temp ⁽³⁾
UC385TD-2	OBSOLETE	DDPAK/ TO-263	KTT	5		TBD	Call TI	Call TI
UC385TD-3	OBSOLETE	DDPAK/ TO-263	KTT	5		TBD	Call TI	Call TI
UC385TD-ADJ	OBSOLETE	DDPAK/ TO-263	KTT	5		TBD	Call TI	Call TI
UC385TDKTTT-1	ACTIVE	DDPAK/ TO-263	KTT	5	50	Green (RoHS & no Sb/Br)	CU SN	Level-2-260C-1 YEAR
UC385TDKTTT-1G3	ACTIVE	DDPAK/ TO-263	KTT	5	50	Green (RoHS & no Sb/Br)	CU SN	Level-2-260C-1 YEAR
UC385TDKTTT-3	ACTIVE	DDPAK/ TO-263	KTT	5	50	Green (RoHS & no Sb/Br)	CU SN	Level-2-260C-1 YEAR
UC385TDKTTT-3G3	ACTIVE	DDPAK/ TO-263	KTT	5	50	Green (RoHS & no Sb/Br)	CU SN	Level-2-260C-1 YEAR
UC385TDKTTT-ADJ	ACTIVE	DDPAK/ TO-263	KTT	5	50	Green (RoHS & no Sb/Br)	CU SN	Level-2-260C-1 YEAR
UC385TDKTTT-ADJG3	ACTIVE	DDPAK/ TO-263	KTT	5	50	Green (RoHS & no Sb/Br)	CU SN	Level-2-260C-1 YEAR
UC385TDTR-1	ACTIVE	DDPAK/ TO-263	KTT	5	500	Green (RoHS & no Sb/Br)	CU SN	Level-2-260C-1 YEAR
UC385TDTR-1G3	ACTIVE	DDPAK/ TO-263	KTT	5	500	Green (RoHS & no Sb/Br)	CU SN	Level-2-260C-1 YEAR
UC385TDTR-3	ACTIVE	DDPAK/ TO-263	KTT	5	500	Green (RoHS & no Sb/Br)	CU SN	Level-2-260C-1 YEAR
UC385TDTR-3G3	ACTIVE	DDPAK/ TO-263	KTT	5	500	Green (RoHS & no Sb/Br)	CU SN	Level-2-260C-1 YEAR
UC385TDTR-ADJ	ACTIVE	DDPAK/ TO-263	KTT	5	500	Green (RoHS & no Sb/Br)	CU SN	Level-2-260C-1 YEAR
UC385TDTR-ADJE3	ACTIVE	DDPAK/ TO-263	KTT	5	500	Green (RoHS & no Sb/Br)	CU SN	Level-2-260C-1 YEAR
UC385TDTR-ADJG3	ACTIVE	DDPAK/ TO-263	KTT	5	500	Green (RoHS & no Sb/Br)	CU SN	Level-2-260C-1 YEAR
UC385TH-ADJ	OBSOLETE	TO-220	KC	5		TBD	Call TI	Call TI

⁽¹⁾ The marketing status values are defined as follows:

ACTIVE: Product device recommended for new designs.

LIFEBUY: TI has announced that the device will be discontinued, and a lifetime-buy period is in effect.

NRND: Not recommended for new designs. Device is in production to support existing customers, but TI does not recommend using this part in a new design.

PREVIEW: Device has been announced but is not in production. Samples may or may not be available.

OBSOLETE: TI has discontinued the production of the device.

⁽²⁾ Eco Plan - The planned eco-friendly classification: Pb-Free (RoHS), Pb-Free (RoHS Exempt), or Green (RoHS & no Sb/Br) - please check <http://www.ti.com/productcontent> for the latest availability information and additional product content details.

TBD: The Pb-Free/Green conversion plan has not been defined.

Pb-Free (RoHS): TI's terms "Lead-Free" or "Pb-Free" mean semiconductor products that are compatible with the current RoHS requirements for all 6 substances, including the requirement that lead not exceed 0.1% by weight in homogeneous materials. Where designed to be soldered at high temperatures, TI Pb-Free products are suitable for use in specified lead-free processes.

Pb-Free (RoHS Exempt): This component has a RoHS exemption for either 1) lead-based flip-chip solder bumps used between the die and package, or 2) lead-based die adhesive used between the die and leadframe. The component is otherwise considered Pb-Free (RoHS compatible) as defined above.

Green (RoHS & no Sb/Br): TI defines "Green" to mean Pb-Free (RoHS compatible), and free of Bromine (Br) and Antimony (Sb) based flame retardants (Br or Sb do not exceed 0.1% by weight in homogeneous material)

⁽³⁾ MSL, Peak Temp. -- The Moisture Sensitivity Level rating according to the JEDEC industry standard classifications, and peak solder temperature.

Important Information and Disclaimer:The information provided on this page represents TI's knowledge and belief as of the date that it is provided. TI bases its knowledge and belief on information provided by third parties, and makes no representation or warranty as to the accuracy of such information. Efforts are underway to better integrate information from third parties. TI has taken and continues to take reasonable steps to provide representative and accurate information but may not have conducted destructive testing or chemical analysis on incoming materials and chemicals. TI and TI suppliers consider certain information to be proprietary, and thus CAS numbers and other limited information may not be available for release.

In no event shall TI's liability arising out of such information exceed the total purchase price of the TI part(s) at issue in this document sold by TI to Customer on an annual basis.

TAPE AND REEL INFORMATION

QUADRANT ASSIGNMENTS FOR PIN 1 ORIENTATION IN TAPE

*All dimensions are nominal

Device	Package Type	Package Drawing	Pins	SPQ	Reel Diameter (mm)	Reel Width W1 (mm)	A0 (mm)	B0 (mm)	K0 (mm)	P1 (mm)	W (mm)	Pin1 Quadrant
UC285TDKTTT-1	DDPAK/ TO-263	KTT	5	50	330.0	24.4	10.6	15.6	4.9	16.0	24.0	Q2
UC285TDKTTT-3	DDPAK/ TO-263	KTT	5	50	330.0	24.4	10.6	15.6	4.9	16.0	24.0	Q2
UC285TDKTTT-ADJ	DDPAK/ TO-263	KTT	5	50	330.0	24.4	10.6	15.6	4.9	16.0	24.0	Q2
UC385TDKTTT-1	DDPAK/ TO-263	KTT	5	50	330.0	24.4	10.6	15.6	4.9	16.0	24.0	Q2
UC385TDKTTT-3	DDPAK/ TO-263	KTT	5	50	330.0	24.4	10.6	15.6	4.9	16.0	24.0	Q2
UC385TDKTTT-ADJ	DDPAK/ TO-263	KTT	5	50	330.0	24.4	10.6	15.6	4.9	16.0	24.0	Q2
UC385TDTR-1	DDPAK/ TO-263	KTT	5	500	330.0	24.4	10.6	15.6	4.9	16.0	24.0	Q2
UC385TDTR-3	DDPAK/ TO-263	KTT	5	500	330.0	24.4	10.6	15.6	4.9	16.0	24.0	Q2
UC385TDTR-ADJ	DDPAK/ TO-263	KTT	5	500	330.0	24.4	10.6	15.6	4.9	16.0	24.0	Q2

TAPE AND REEL BOX DIMENSIONS



*All dimensions are nominal

Device	Package Type	Package Drawing	Pins	SPQ	Length (mm)	Width (mm)	Height (mm)
UC285TDKTTT-1	DDPAK/TO-263	KTT	5	50	346.0	346.0	41.0
UC285TDKTTT-3	DDPAK/TO-263	KTT	5	50	346.0	346.0	41.0
UC285TDKTTT-ADJ	DDPAK/TO-263	KTT	5	50	346.0	346.0	41.0
UC385TDKTTT-1	DDPAK/TO-263	KTT	5	50	346.0	346.0	41.0
UC385TDKTTT-3	DDPAK/TO-263	KTT	5	50	346.0	346.0	41.0
UC385TDKTTT-ADJ	DDPAK/TO-263	KTT	5	50	346.0	346.0	41.0
UC385TDTR-1	DDPAK/TO-263	KTT	5	500	346.0	346.0	41.0
UC385TDTR-3	DDPAK/TO-263	KTT	5	500	346.0	346.0	41.0
UC385TDTR-ADJ	DDPAK/TO-263	KTT	5	500	346.0	346.0	41.0

KTT (R-PSFM-G5)

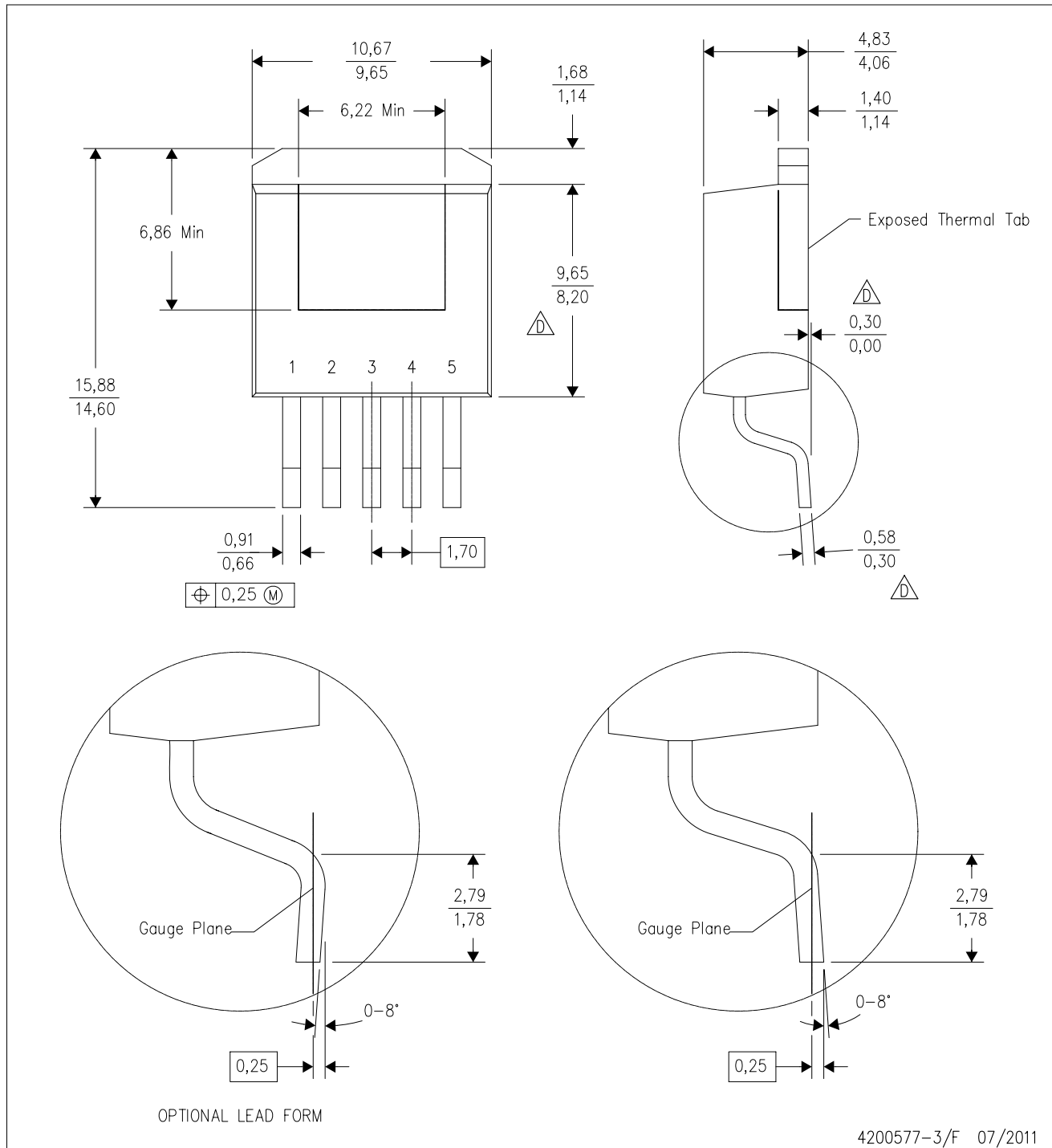
PLASTIC FLANGE-MOUNT PACKAGE



- NOTES:
- All linear dimensions are in millimeters.
 - This drawing is subject to change without notice.
 - Body dimensions do not include mold flash or protrusion. Mold flash or protrusion not to exceed 0.005 (0,13) per side.
-  Falls within JEDEC TO-263 variation BA, except minimum lead thickness, maximum seating height, and minimum body length.

KTT (R-PSFM-G5)

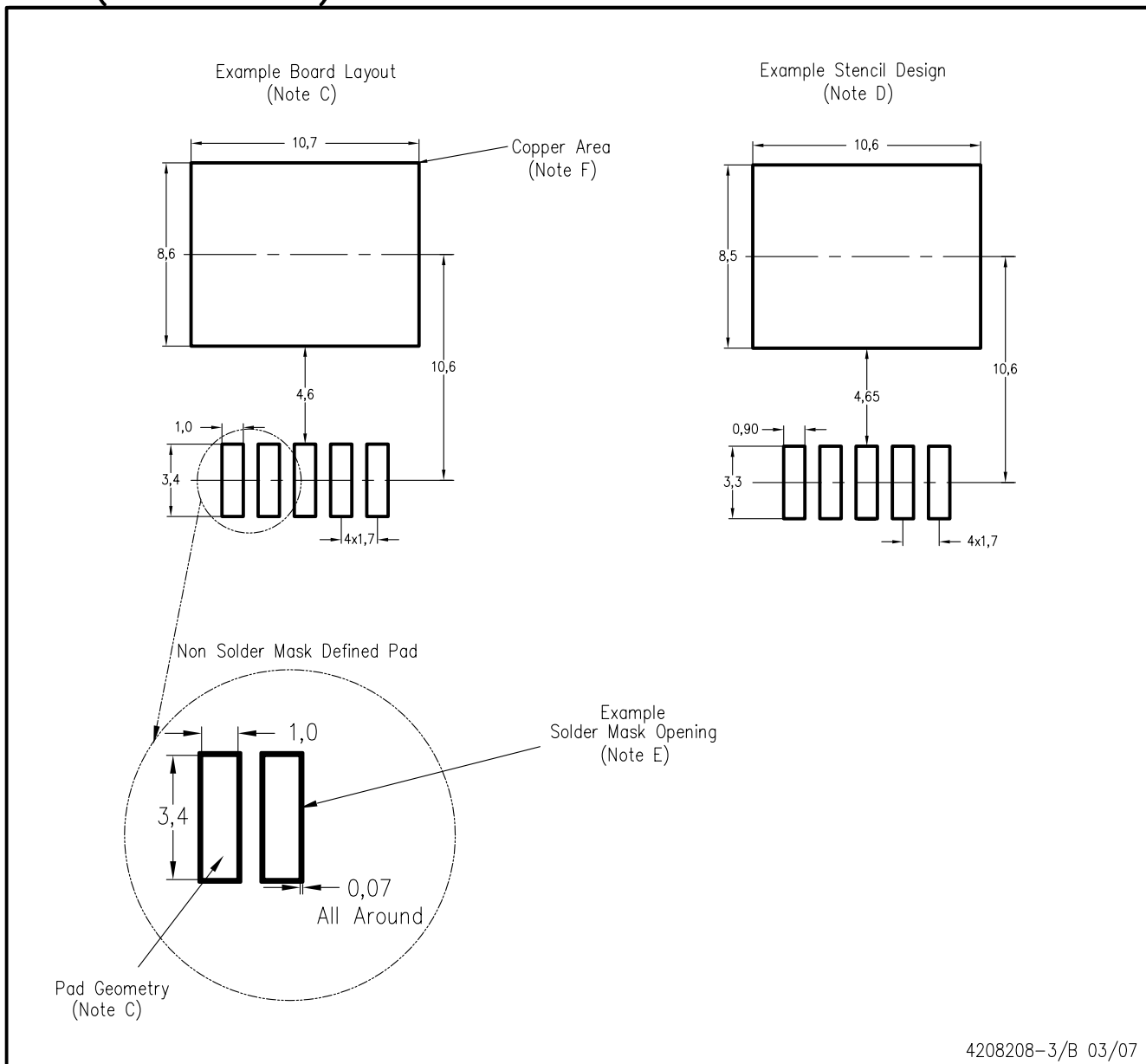

- NOTES:
- A. All linear dimensions are in millimeters.
 - B. This drawing is subject to change without notice.
 - C. Publication IPC-SM-782 is recommended for alternate designs.
 - D. Laser cutting apertures with trapezoidal walls and also rounding corners will offer better paste release. Customers should contact their board assembly site for stencil design recommendations. Refer to IPC-7525.
 - E. Customers should contact their board fabrication site for solder mask tolerances between and around signal pads.
 - F. This package is designed to be soldered to a thermal pad on the board. Refer to the Product Datasheet for specific thermal information, via requirements, and recommended thermal pad size. For thermal pad sizes larger than shown a solder mask defined pad is recommended in order to maintain the solderable pad geometry while increasing copper area.

KC (R-PSFM-T5)

PLASTIC FLANGE-MOUNT PACKAGE

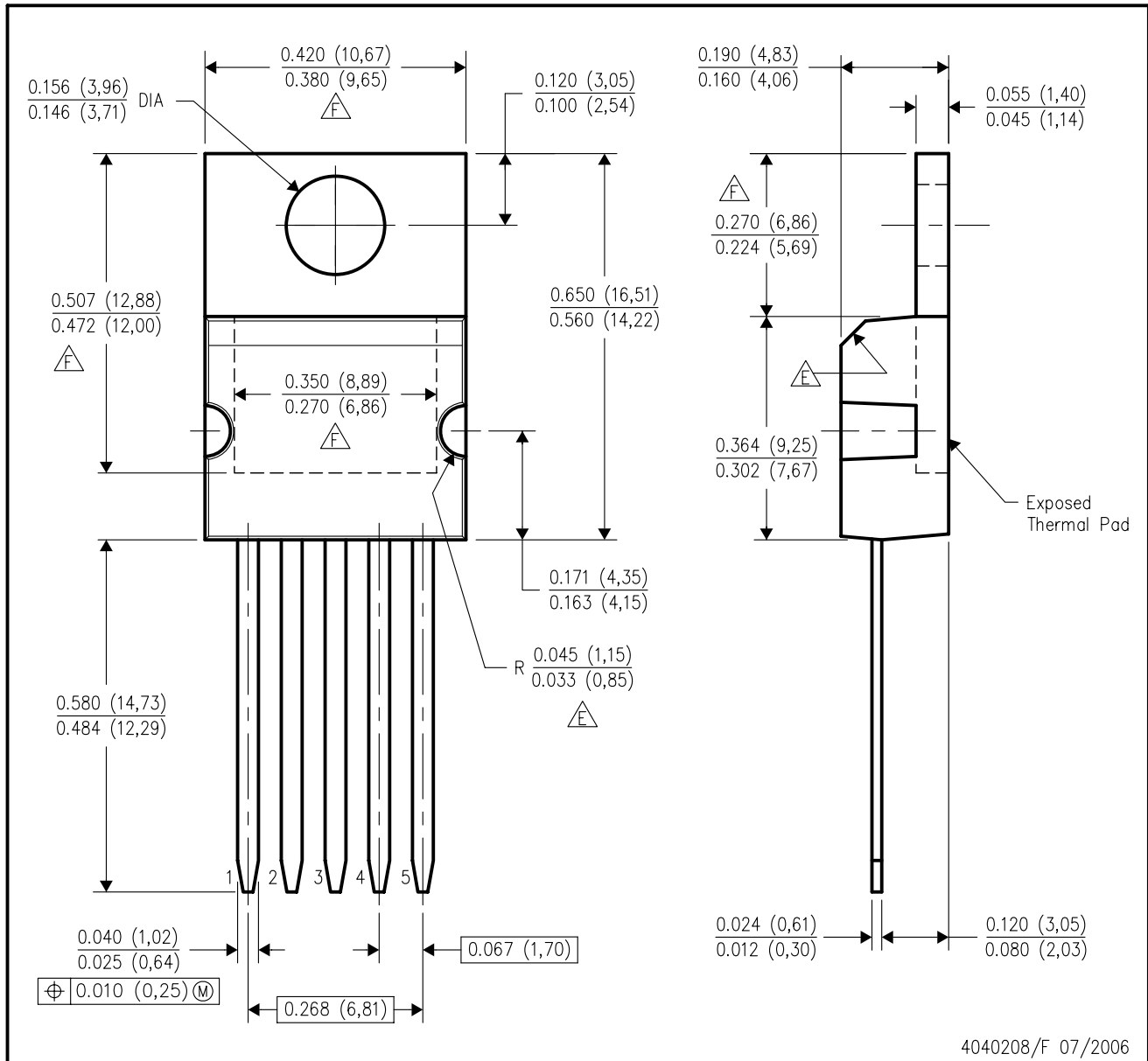

- NOTES:
- All linear dimensions are in inches (millimeters).
 - This drawing is subject to change without notice.
 - All lead dimensions apply before solder dip.
 - The center lead is in electrical contact with the mounting tab.
- \triangle These features are optional.
- \triangle Thermal pad contour optional within these dimensions.

IMPORTANT NOTICE

Texas Instruments Incorporated and its subsidiaries (TI) reserve the right to make corrections, modifications, enhancements, improvements, and other changes to its products and services at any time and to discontinue any product or service without notice. Customers should obtain the latest relevant information before placing orders and should verify that such information is current and complete. All products are sold subject to TI's terms and conditions of sale supplied at the time of order acknowledgment.

TI warrants performance of its hardware products to the specifications applicable at the time of sale in accordance with TI's standard warranty. Testing and other quality control techniques are used to the extent TI deems necessary to support this warranty. Except where mandated by government requirements, testing of all parameters of each product is not necessarily performed.

TI assumes no liability for applications assistance or customer product design. Customers are responsible for their products and applications using TI components. To minimize the risks associated with customer products and applications, customers should provide adequate design and operating safeguards.

TI does not warrant or represent that any license, either express or implied, is granted under any TI patent right, copyright, mask work right, or other TI intellectual property right relating to any combination, machine, or process in which TI products or services are used. Information published by TI regarding third-party products or services does not constitute a license from TI to use such products or services or a warranty or endorsement thereof. Use of such information may require a license from a third party under the patents or other intellectual property of the third party, or a license from TI under the patents or other intellectual property of TI.

Reproduction of TI information in TI data books or data sheets is permissible only if reproduction is without alteration and is accompanied by all associated warranties, conditions, limitations, and notices. Reproduction of this information with alteration is an unfair and deceptive business practice. TI is not responsible or liable for such altered documentation. Information of third parties may be subject to additional restrictions.

Resale of TI products or services with statements different from or beyond the parameters stated by TI for that product or service voids all express and any implied warranties for the associated TI product or service and is an unfair and deceptive business practice. TI is not responsible or liable for any such statements.

TI products are not authorized for use in safety-critical applications (such as life support) where a failure of the TI product would reasonably be expected to cause severe personal injury or death, unless officers of the parties have executed an agreement specifically governing such use. Buyers represent that they have all necessary expertise in the safety and regulatory ramifications of their applications, and acknowledge and agree that they are solely responsible for all legal, regulatory and safety-related requirements concerning their products and any use of TI products in such safety-critical applications, notwithstanding any applications-related information or support that may be provided by TI. Further, Buyers must fully indemnify TI and its representatives against any damages arising out of the use of TI products in such safety-critical applications.

TI products are neither designed nor intended for use in military/aerospace applications or environments unless the TI products are specifically designated by TI as military-grade or "enhanced plastic." Only products designated by TI as military-grade meet military specifications. Buyers acknowledge and agree that any such use of TI products which TI has not designated as military-grade is solely at the Buyer's risk, and that they are solely responsible for compliance with all legal and regulatory requirements in connection with such use.

TI products are neither designed nor intended for use in automotive applications or environments unless the specific TI products are designated by TI as compliant with ISO/TS 16949 requirements. Buyers acknowledge and agree that, if they use any non-designated products in automotive applications, TI will not be responsible for any failure to meet such requirements.

Following are URLs where you can obtain information on other Texas Instruments products and application solutions:

Products

Audio	www.ti.com/audio
Amplifiers	amplifier.ti.com
Data Converters	dataconverter.ti.com
DLP® Products	www.dlp.com
DSP	dsp.ti.com
Clocks and Timers	www.ti.com/clocks
Interface	interface.ti.com
Logic	logic.ti.com
Power Mgmt	power.ti.com
Microcontrollers	microcontroller.ti.com
RFID	www.ti-rfid.com
RF/IF and ZigBee® Solutions	www.ti.com/lprf

Applications

Communications and Telecom	www.ti.com/communications
Computers and Peripherals	www.ti.com/computers
Consumer Electronics	www.ti.com/consumer-apps
Energy and Lighting	www.ti.com/energy
Industrial	www.ti.com/industrial
Medical	www.ti.com/medical
Security	www.ti.com/security
Space, Avionics and Defense	www.ti.com/space-avionics-defense
Transportation and Automotive	www.ti.com/automotive
Video and Imaging	www.ti.com/video
Wireless	www.ti.com/wireless-apps

TI E2E Community Home Page

e2e.ti.com

Mailing Address: Texas Instruments, Post Office Box 655303, Dallas, Texas 75265
Copyright © 2011, Texas Instruments Incorporated

Looking for pricing, stock, or lifecycle information?

Click below to explore more details on WIN SOURCE:

 [View UC385TDKTTT-1G3 on WIN SOURCE](#)

 [Texas Instruments](#) Information

Optimize Your Supply Chain with WIN SOURCE Solutions

-  Global Sourcing Solution
-  Obsolete Management
-  Cost Control Management
-  Shortage Management
-  Alternative Solution
-  Excess Inventory Management