



**THE DATASHEET OF
UC3901QTR**



Isolated Feedback Generator

FEATURES

- An Amplitude-Modulation System for Transformer Coupling an Isolated Feedback Error Signal
- Low-Cost Alternative to Optical Couplers
- Internal 1% Reference and Error Amplifier
- Internal Carrier Oscillator Usable to 5MHz
- Modulator Synchronizable to an External Clock
- Loop Status Monitor

DESCRIPTION

The UC1901 family is designed to solve many of the problems associated with closing a feedback control loop across a voltage isolation boundary. As a stable and reliable alternative to an optical coupler, these devices feature an amplitude modulation system which allows a loop error signal to be coupled with a small RF transformer or capacitor.

The programmable, high-frequency oscillator within the UC1901 series permits the use of smaller, less expensive transformers which can readily be built to meet the isolation requirements of today's line-operated power systems. As an alternative to RF operation, the external clock input to these devices allows synchronization to a system clock or to the switching frequency of a SMPS.

An additional feature is a status monitoring circuit which provides an active-low output when the sensed error voltage is within $\pm 10\%$ of the reference. The DRIVERB output, DRIVERA output, and STATUS output are disabled until the input supply has reached a sufficient level to allow proper operation of the device.

Since these devices can also be used as a DC driver for optical couplers, the benefits of 4.5 to 40V supply operation, a 1% accurate reference, and a high gain general purpose amplifier offer advantages even though an AC system may not be desired.

UC1901 SIMPLIFIED SCHEMATIC

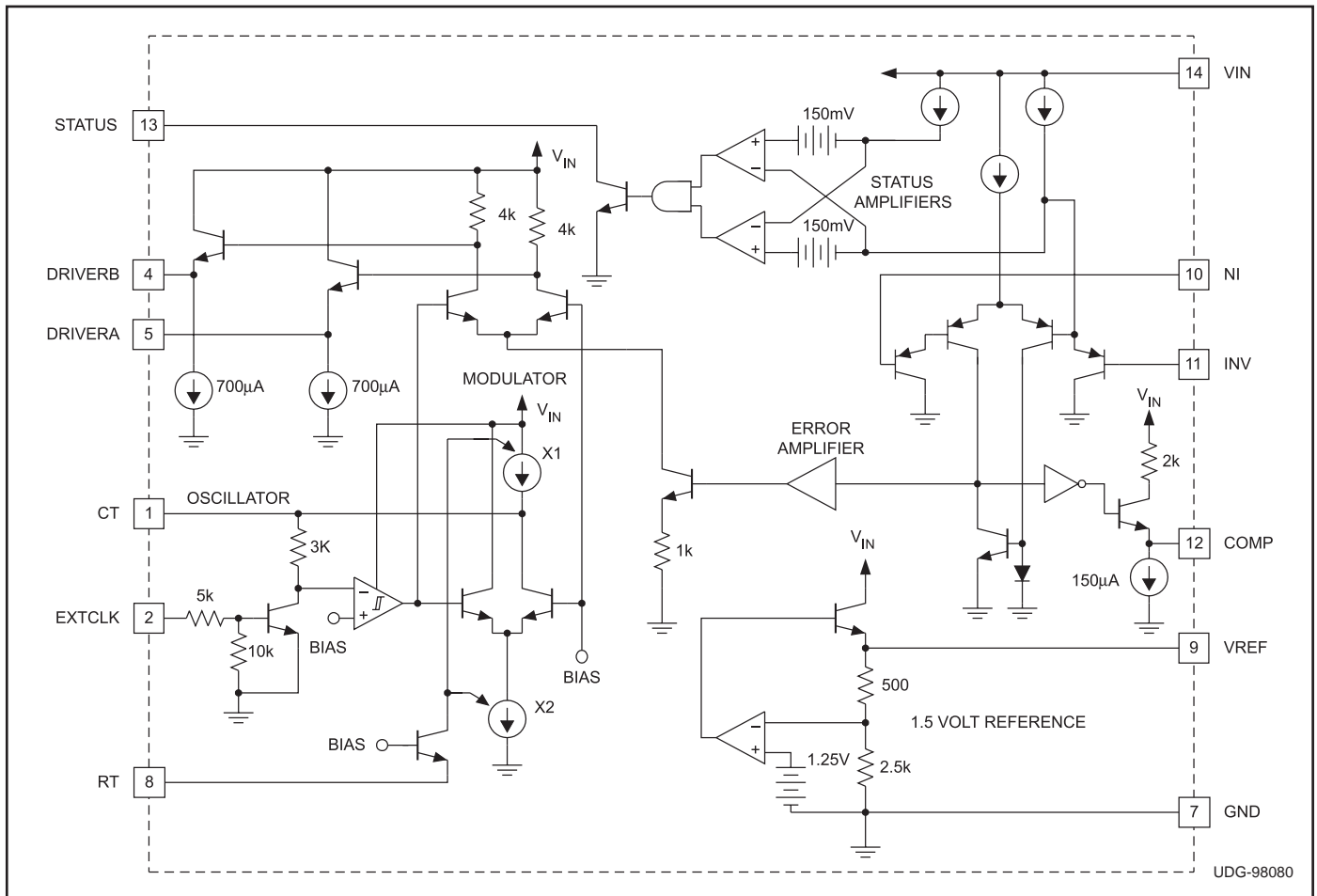

ABSOLUTE MAXIMUM RATINGS (Note 1)

Input Supply Voltage, V_{IN}	40V
Reference Output Current	-10mA
Driver Output Currents	-35mA
Status Indicator Voltage	40V
Status Indicator Current	20mA
Ext. Clock Input	40V
Error Amplifier Inputs	-0.5V to +35V
Power Dissipation at $T_A = 25^\circ\text{C}$	1000mW
Power Dissipation at $T_c = 25^\circ\text{C}$	2000mW
Operating Junction Temperature	-55°C to +150°C
Storage Temperature	-65°C to +150°C
Lead Temperature (Soldering, 10 seconds)	300°C

Note 1: Voltages are referenced to ground, Pin 7. Currents are positive into, negative out of the specified terminal.

Note 2: Consult Packaging section of Databook for thermal limitations and considerations of package.

CONNECTION DIAGRAMS

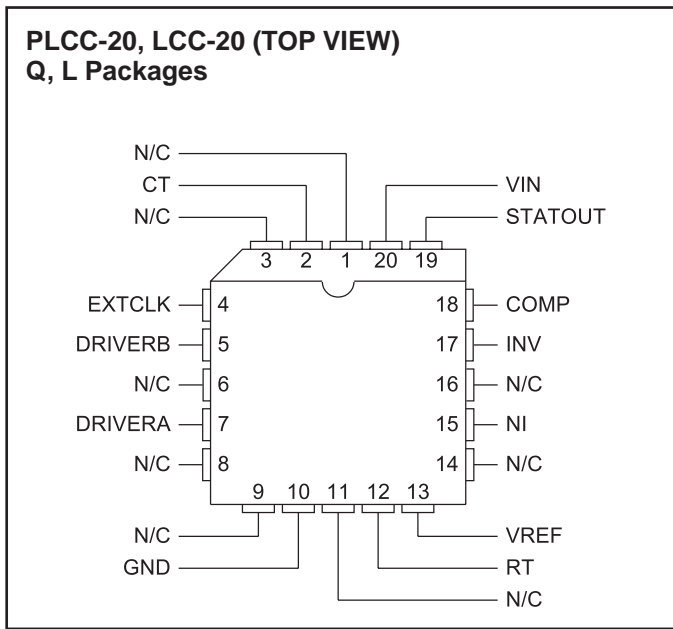
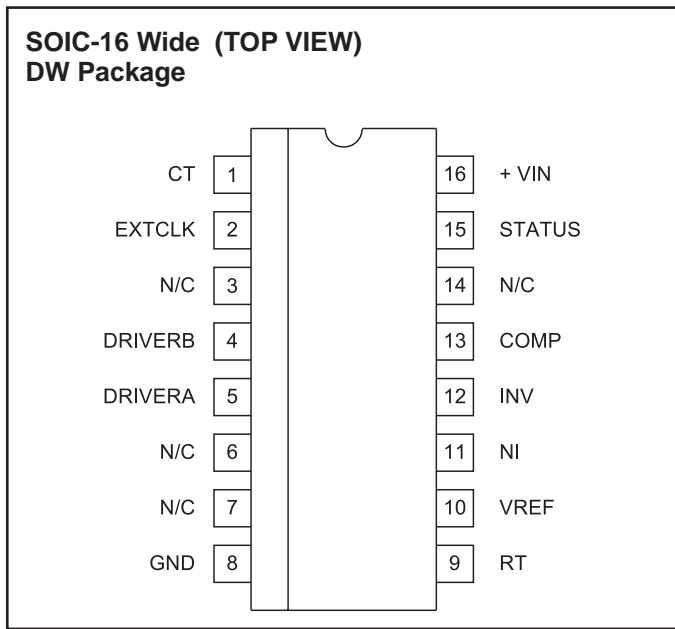
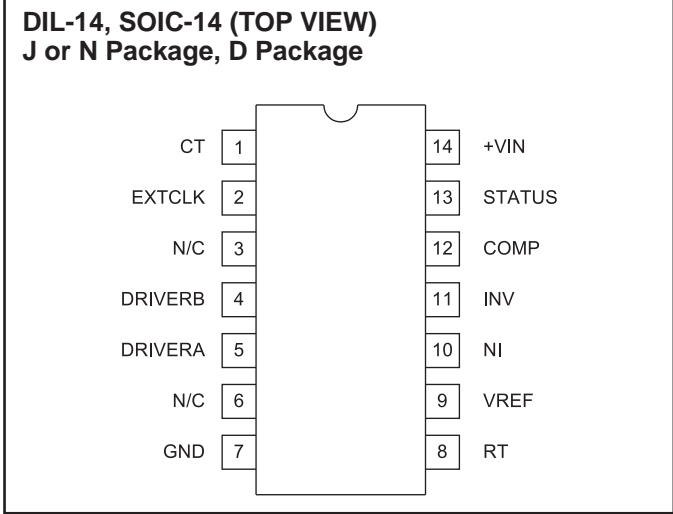

TEMPERATURE AND PACKAGE SELECTION GUIDE

	TEMPERATURE RANGE	AVAILABLE PACKAGES
UC1901	-55°C to +125°C	J, L
UC2901	-40°C to +85°C	D, DW, J, N, Q
UC3901	0°C to +70°C	D, DW, J, N, Q

ELECTRICAL CHARACTERISTICS Unless otherwise stated, these specifications apply for $V_{IN} = 10V$, $R_T = 10k\Omega$, $C_T = 820pF$, $T_A = T_J$.

PARAMETER	TEST CONDITIONS	UC1901/UC2901			UC3901			UNITS
		MIN	TYP	MAX	MIN	TYP	MAX	
Reference Section								
Output Voltage	$T_J = 25^\circ C$	1.485	1.5	1.515	1.47	1.5	1.53	V
	$T_{MIN} \leq T_J \leq T_{MAX}$	1.470	1.5	1.530	1.455	1.5	1.545	
Line Regulation	$V_{IN} = 4.5$ to $35V$		2	10		2	15	mV
Load Regulation	$I_{OUT} = 0$ to $5mA$		4	10		4	15	mV
Short Circuit Current	$T_J = 25^\circ C$		-35	-55		-35	-55	mV
Error Amplifier Section (To Compensation Terminal)								
Input Offset Voltage	$V_{CM} = 1.5V$		1	4		1	8	mV
Input Bias Current	$V_{CM} = 1.5V$		-1	-3		-1	-6	μA
Input Offset Current	$V_{CM} = 1.5V$		0.1	1		0.1	2	μA
Small Signal Open Loop Gain		40	60		40	60		dB
CMRR	$V_{CM} = 0.5$ to $7.5V$	60	80		60	80		dB
PSRR	$V_{IN} = 5$ to $25V$	80	100		80	100		dB
Output Swing, ΔV_o		0.4	0.7		0.4	0.7		V
Maximum Sink Current		90	150		90	150		μA
Maximum Source Current		-2	-3		-2	-3		mA
Gain Band Width Product			1			1		MHz
Slew Rate			0.3			0.3		V/ μS
Modulators/Drivers Section (From Compensation Terminal)								
Voltage Gain		11	12	13	10	12	14	dB
Output Swing		± 1.6	± 2.8		± 1.6	± 2.8		V
Driver Sink Current		500	700		500	700		μA
Driver Source Current		-15	-35		-15	-35		mA
Gain Band Width Product			25			25		MHz
Oscillator Section								
Initial Accuracy	$T_J = 25^\circ C$	140	150	160	130	150	170	kHz
	$T_{MIN} \leq T_J \leq T_{MAX}$	130		170	120		180	kHz
Line Sensitivity	$V_{IN} = 5$ to $35V$.15	.35		.15	.60	%/V
Maximum Frequency	$R_T = 10k$, $C_T = 10pF$		5			5		MHz
Ext. Clock Low Threshold	Pin 1 (C_T) = V_{IN}	0.5			0.5			V
Ext. Clock High Threshold	Pin 1 (C_T) = V_{IN}			1.6			1.6	V
Status Indicator Section								
Input Voltage Window	@ E/A Inputs, $V_{CM} = 1.5V$	± 135	± 150	± 165	± 130	± 150	± 170	mV
Saturation Voltage	E/A Δ Input = $0V$, $I_{SINK} = 1.6mA$			0.45			0.45	V
Max. Output Current	Pin 13 = $3V$, E/A Δ Input = $0.0V$	8	15		8	15		mA
Leakage Current	Pin 13 = $40V$, E/A Δ Input = $0.2V$.05	1		.05	5	μA
Supply Current	$V_{IN} = 35V$		5	8		5	10	mA
UVLO Section								
Drivers Enabled Threshold	At Input Supply V_{IN}		3.9	4.5		3.9	4.5	V
Status Output Enabled Threshold	At Input Supply V_{IN}		3.9	4.5		3.9	4.5	V
Change in Reference Output	When V_{IN} Reaches UVLO Threshold		-2	-30		-2	-30	mV

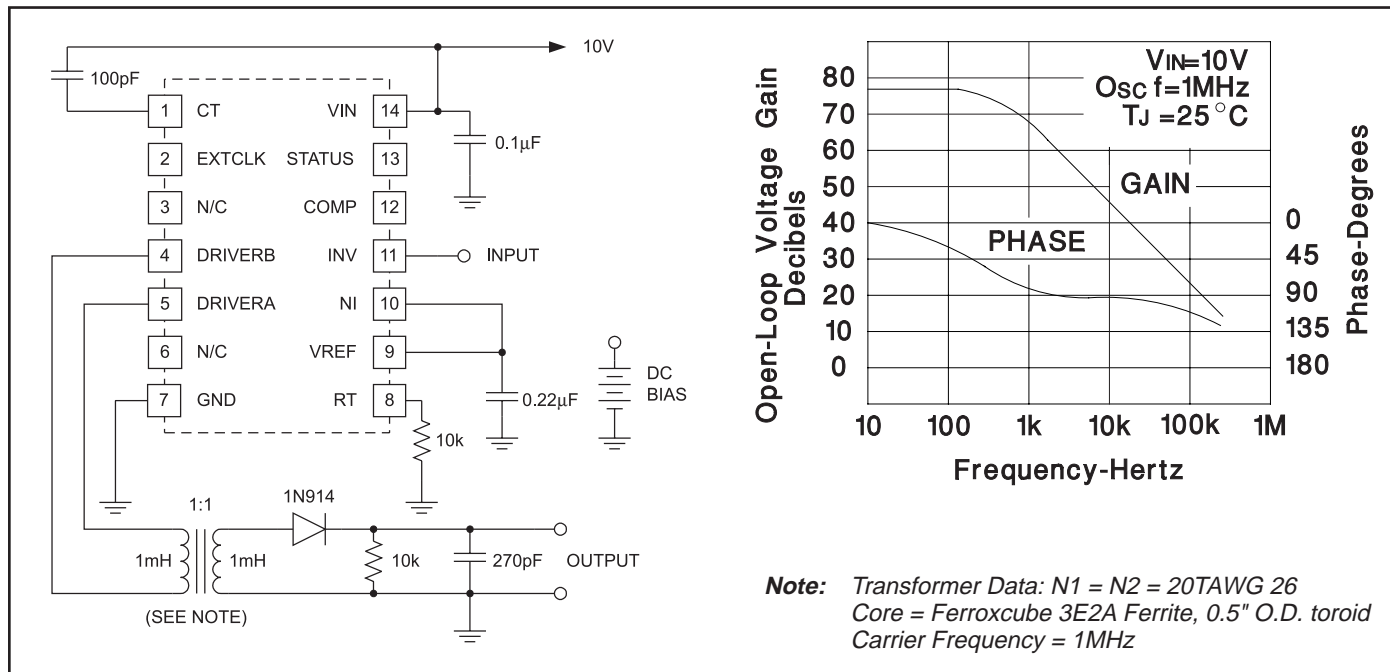

Figure 1. Transformer Coupled Open Loop Transfer Function

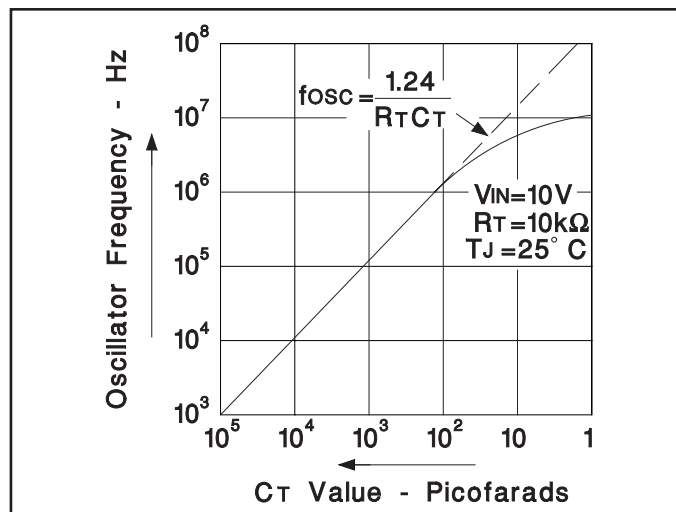

Figure 2. Oscillator Frequency

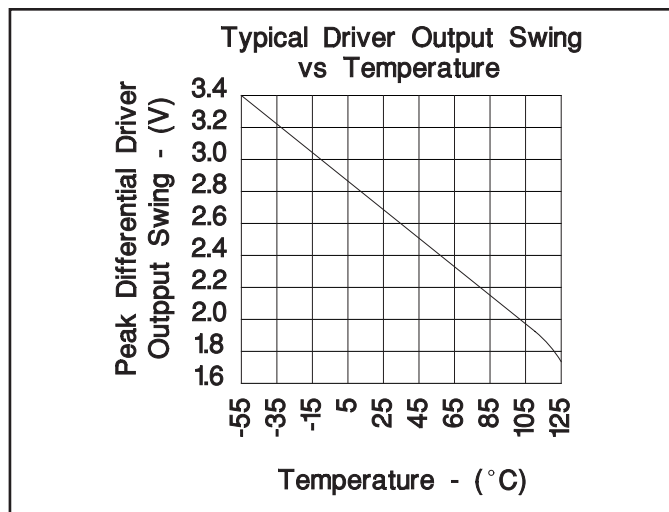

Figure 3. Typical Driver Output Swing vs Temperature

APPLICATION INFORMATION

The error amplifier compensation terminal, Pin 12, is intended as a source of feedback to the amplifier's inverting input at Pin 11. For most applications, a series DC blocking capacitor should be part of the feedback network. The amplifier is internally compensated for unity feedback.

The waveform at the driver outputs is a squarewave with an amplitude that is proportional to the error amplifier input signal. There is a fixed 12dB of gain from the error amplifier compensation pin to the modulator driver outputs. The frequency of the output waveform is controlled by either the internal oscillator or an external clock signal.

With the internal oscillator the squarewave will have a fixed 50% duty cycle. If the internal oscillator is disabled by connecting Pin 1, C_R , to V_{IN} then the frequency and duty cycle of the output will be determined by the input clock waveform at Pin 2. If the oscillator remains disabled and there is not clock input at Pin 2, there will be a linear 12dB of signal gain to one or the other of the driver outputs depending on the DC state of Pin 2.

The driver outputs are emitter followers which will source a minimum of 15mA of current. The sink current, internally limited at 700 μ A, can be increased by adding resistors to ground at the driver outputs.

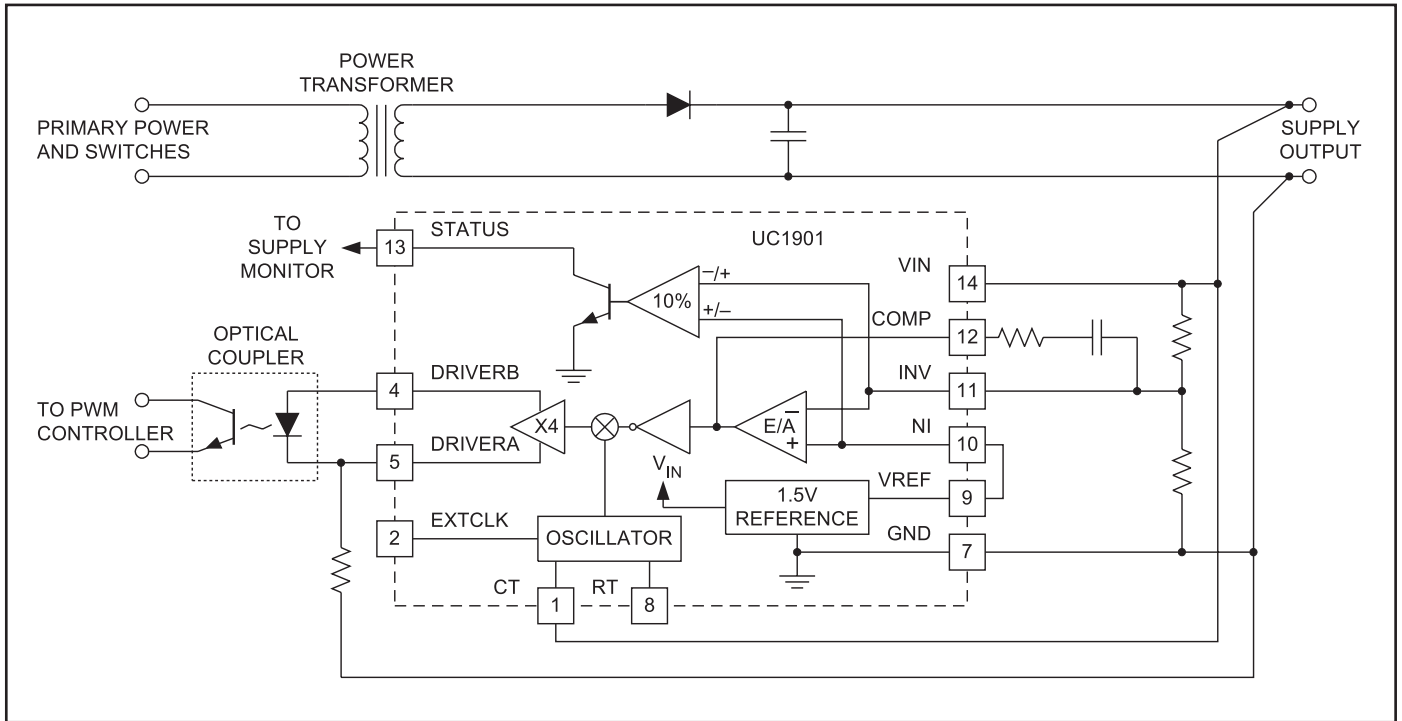

PACKAGING INFORMATION

Orderable Device	Status (1)	Package Type	Package Drawing	Pins	Package Qty	Eco Plan (2)	Lead finish/ Ball material (6)	MSL Peak Temp (3)	Op Temp (°C)	Device Marking (4/5)	Samples
5962-89441012A	ACTIVE	LCCC	FK	20	55	Non-RoHS & Green	SNPB	N / A for Pkg Type	-55 to 125	5962-89441012A UC1901L/ 883B	Samples
5962-8944101CA	ACTIVE	CDIP	J	14	25	Non-RoHS & Green	SNPB	N / A for Pkg Type	-55 to 125	5962-8944101CA UC1901J/883B	Samples
5962-8944101VCA	ACTIVE	CDIP	J	14	25	Non-RoHS & Green	SNPB	N / A for Pkg Type	-55 to 125	5962-8944101VCA UC1901JQMLV	Samples
UC1901J	ACTIVE	CDIP	J	14	25	Non-RoHS & Green	SNPB	N / A for Pkg Type	-55 to 125	UC1901J	Samples
UC1901J883B	ACTIVE	CDIP	J	14	25	Non-RoHS & Green	SNPB	N / A for Pkg Type	-55 to 125	5962-8944101CA UC1901J/883B	Samples
UC1901L	ACTIVE	LCCC	FK	20	55	Non-RoHS & Green	SNPB	N / A for Pkg Type	-55 to 125	UC1901L	Samples
UC1901L883B	ACTIVE	LCCC	FK	20	55	Non-RoHS & Green	SNPB	N / A for Pkg Type	-55 to 125	5962-89441012A UC1901L/ 883B	Samples
UC2901D	ACTIVE	SOIC	D	14	50	RoHS & Green	NIPDAU	Level-2-260C-1 YEAR	-40 to 85	UC2901D	Samples
UC2901DTR	ACTIVE	SOIC	D	14	2500	RoHS & Green	NIPDAU	Level-2-260C-1 YEAR	-40 to 85	UC2901D	Samples
UC2901J	ACTIVE	CDIP	J	14	25	Non-RoHS & Green	SNPB	N / A for Pkg Type	-40 to 85	UC2901J	Samples
UC2901N	ACTIVE	PDIP	N	14	25	RoHS & Green	NIPDAU	N / A for Pkg Type	-40 to 85	UC2901N	Samples
UC3901D	ACTIVE	SOIC	D	14	50	RoHS & Green	NIPDAU	Level-2-260C-1 YEAR	0 to 70	UC3901D	Samples
UC3901DTR	LIFEBUY	SOIC	D	14	2500	RoHS & Green	NIPDAU	Level-2-260C-1 YEAR	0 to 70	UC3901D	
UC3901DW	LIFEBUY	SOIC	DW	16	40	RoHS & Green	NIPDAU	Level-2-260C-1 YEAR	0 to 70	UC3901DW	
UC3901N	ACTIVE	PDIP	N	14	25	RoHS & Green	NIPDAU	N / A for Pkg Type	0 to 70	UC3901N	Samples

(1) The marketing status values are defined as follows:
ACTIVE: Product device recommended for new designs.

LIFEBUY: TI has announced that the device will be discontinued, and a lifetime-buy period is in effect.

NRND: Not recommended for new designs. Device is in production to support existing customers, but TI does not recommend using this part in a new design.

PREVIEW: Device has been announced but is not in production. Samples may or may not be available.

OBSOLETE: TI has discontinued the production of the device.

⁽²⁾ **RoHS:** TI defines "RoHS" to mean semiconductor products that are compliant with the current EU RoHS requirements for all 10 RoHS substances, including the requirement that RoHS substance do not exceed 0.1% by weight in homogeneous materials. Where designed to be soldered at high temperatures, "RoHS" products are suitable for use in specified lead-free processes. TI may reference these types of products as "Pb-Free".

RoHS Exempt: TI defines "RoHS Exempt" to mean products that contain lead but are compliant with EU RoHS pursuant to a specific EU RoHS exemption.

Green: TI defines "Green" to mean the content of Chlorine (Cl) and Bromine (Br) based flame retardants meet JS709B low halogen requirements of <=1000ppm threshold. Antimony trioxide based flame retardants must also meet the <=1000ppm threshold requirement.

⁽³⁾ MSL, Peak Temp. - The Moisture Sensitivity Level rating according to the JEDEC industry standard classifications, and peak solder temperature.

⁽⁴⁾ There may be additional marking, which relates to the logo, the lot trace code information, or the environmental category on the device.

⁽⁵⁾ Multiple Device Markings will be inside parentheses. Only one Device Marking contained in parentheses and separated by a "~" will appear on a device. If a line is indented then it is a continuation of the previous line and the two combined represent the entire Device Marking for that device.

⁽⁶⁾ Lead finish/Ball material - Orderable Devices may have multiple material finish options. Finish options are separated by a vertical ruled line. Lead finish/Ball material values may wrap to two lines if the finish value exceeds the maximum column width.

Important Information and Disclaimer:The information provided on this page represents TI's knowledge and belief as of the date that it is provided. TI bases its knowledge and belief on information provided by third parties, and makes no representation or warranty as to the accuracy of such information. Efforts are underway to better integrate information from third parties. TI has taken and continues to take reasonable steps to provide representative and accurate information but may not have conducted destructive testing or chemical analysis on incoming materials and chemicals. TI and TI suppliers consider certain information to be proprietary, and thus CAS numbers and other limited information may not be available for release.

In no event shall TI's liability arising out of such information exceed the total purchase price of the TI part(s) at issue in this document sold by TI to Customer on an annual basis.

OTHER QUALIFIED VERSIONS OF UC1901, UC1901-SP, UC2901, UC2901-MIL, UC3901 :

● Catalog : [UC3901](#), [UC1901](#)

● Enhanced Product : [UC2901-EP](#), [UC2901-EP](#)

● Military : [UC1901](#)

● Space : [UC1901-SP](#), [UC1901-SP](#)

NOTE: Qualified Version Definitions:

- Catalog - TI's standard catalog product
- Enhanced Product - Supports Defense, Aerospace and Medical Applications
- Military - QML certified for Military and Defense Applications
- Space - Radiation tolerant, ceramic packaging and qualified for use in Space-based application

TAPE AND REEL INFORMATION

QUADRANT ASSIGNMENTS FOR PIN 1 ORIENTATION IN TAPE

*All dimensions are nominal

Device	Package Type	Package Drawing	Pins	SPQ	Reel Diameter (mm)	Reel Width W1 (mm)	A0 (mm)	B0 (mm)	K0 (mm)	P1 (mm)	W (mm)	Pin1 Quadrant
UC2901DTR	SOIC	D	14	2500	330.0	16.4	6.5	9.0	2.1	8.0	16.0	Q1
UC3901DTR	SOIC	D	14	2500	330.0	16.4	6.5	9.0	2.1	8.0	16.0	Q1

TAPE AND REEL BOX DIMENSIONS

*All dimensions are nominal

Device	Package Type	Package Drawing	Pins	SPQ	Length (mm)	Width (mm)	Height (mm)
UC2901DTR	SOIC	D	14	2500	356.0	356.0	35.0
UC3901DTR	SOIC	D	14	2500	356.0	356.0	35.0

TUBE

*All dimensions are nominal

Device	Package Name	Package Type	Pins	SPQ	L (mm)	W (mm)	T (μm)	B (mm)
5962-89441012A	FK	LCCC	20	55	506.98	12.06	2030	NA
UC1901L	FK	LCCC	20	55	506.98	12.06	2030	NA
UC1901L883B	FK	LCCC	20	55	506.98	12.06	2030	NA
UC2901D	D	SOIC	14	50	506.6	8	3940	4.32
UC2901N	N	PDIP	14	25	506	13.97	11230	4.32
UC3901D	D	SOIC	14	50	506.6	8	3940	4.32
UC3901DW	DW	SOIC	16	40	507	12.83	5080	6.6
UC3901N	N	PDIP	14	25	506	13.97	11230	4.32

IMPORTANT NOTICE AND DISCLAIMER

TI PROVIDES TECHNICAL AND RELIABILITY DATA (INCLUDING DATA SHEETS), DESIGN RESOURCES (INCLUDING REFERENCE DESIGNS), APPLICATION OR OTHER DESIGN ADVICE, WEB TOOLS, SAFETY INFORMATION, AND OTHER RESOURCES "AS IS" AND WITH ALL FAULTS, AND DISCLAIMS ALL WARRANTIES, EXPRESS AND IMPLIED, INCLUDING WITHOUT LIMITATION ANY IMPLIED WARRANTIES OF MERCHANTABILITY, FITNESS FOR A PARTICULAR PURPOSE OR NON-INFRINGEMENT OF THIRD PARTY INTELLECTUAL PROPERTY RIGHTS.

These resources are intended for skilled developers designing with TI products. You are solely responsible for (1) selecting the appropriate TI products for your application, (2) designing, validating and testing your application, and (3) ensuring your application meets applicable standards, and any other safety, security, regulatory or other requirements.

These resources are subject to change without notice. TI grants you permission to use these resources only for development of an application that uses the TI products described in the resource. Other reproduction and display of these resources is prohibited. No license is granted to any other TI intellectual property right or to any third party intellectual property right. TI disclaims responsibility for, and you will fully indemnify TI and its representatives against, any claims, damages, costs, losses, and liabilities arising out of your use of these resources.

TI's products are provided subject to [TI's Terms of Sale](#) or other applicable terms available either on [ti.com](https://www.ti.com) or provided in conjunction with such TI products. TI's provision of these resources does not expand or otherwise alter TI's applicable warranties or warranty disclaimers for TI products.

TI objects to and rejects any additional or different terms you may have proposed.

Mailing Address: Texas Instruments, Post Office Box 655303, Dallas, Texas 75265
Copyright © 2024, Texas Instruments Incorporated

Looking for pricing, stock, or lifecycle information?

Click below to explore more details on WIN SOURCE:

 [View UC3901QTR](#) on WIN SOURCE

 [Texas Instruments](#) Information

Optimize Your Supply Chain with WIN SOURCE Solutions

-  Global Sourcing Solution
-  Obsolete Management
-  Cost Control Management
-  Shortage Management
-  Alternative Solution
-  Excess Inventory Management