



**THE DATASHEET OF
AZ4052MTR-G1**



DUAL 4-CHANNEL ANALOG MULTIPLEXER/DEMULTIPLEXER

Description

The AZ4052 is high-speed si-gate CMOS device. The AZ4052 is dual 4-channel analog multiplexers or demultiplexers with common select logic. Each multiplexer has four independent inputs/outputs (pins nY0 to nY3) and a common input/output (pin nZ). The common channel select logics include two digital select inputs (pins S0 and S1) and an active LOW enable input (pin \bar{E}). When pin \bar{E} = LOW, one of the four switches is selected (Low-impedance On-state) with pins S0 and S1. When pin \bar{E} = HIGH, all switches are in the high-impedance Off-state, independent of pins S0 and S1. V_{CC} and GND are the supply voltage pins for the digital control inputs (pins S0, S1 and \bar{E}). The V_{CC} to GND ranges are 3.0V to 10V. The analog inputs/outputs (pins nY0 to nY3 and nZ) can swing between V_{CC} as a positive limit and V_{EE} as a negative limit. V_{CC} - V_{EE} may not exceed 10V. For operation as a digital multiplexer/demultiplexer, V_{EE} is connected to GND (Typically Ground).

The AZ4052 is available in standard packages of SOIC-16 and DIP-16.

Features

- Wide Operation Voltage: $\pm 5.0V$ or 10V
- Low On-resistance:
 - 55 Ω (Typ.) at V_{CC} - V_{EE} = 5V
 - 40 Ω (Typ.) at V_{CC} - V_{EE} = 10V
- Ultra Low THD+N: 0.003% @ 10V, 0.008% @ 5.0V
- Ultra Low Crosstalk: -120dB
- Ultra Low Noise: 6.0 μV_{RMS}
- Operating Temperature: -40°C to +85°C
- **Totally Lead-Free & Fully RoHS Compliant (Notes 1 & 2)**
- **Halogen and Antimony Free. "Green" Device (Note 3)**

Applications

- LCD TV/PDP TV/CRT TV
- 4:1 Multi-channel Signal Selecting

Function Table

Control Input			On Channel	
\bar{E}	S1	S0	-	
L	L	L	nY0	nZ
L	L	H	nY1	nZ
L	H	L	nY2	nZ
L	H	H	nY3	nZ
H	X	X	None	

Notes: 1. No purposely added lead. Fully EU Directive 2002/95/EC (RoHS) & 2011/65/EU (RoHS 2) compliant.
 2. See http://www.diodes.com/quality/lead_free.html for more information about Diodes Incorporated's definitions of Halogen- and Antimony-free, "Green" and Lead-free.
 3. Halogen- and Antimony-free "Green" products are defined as those which contain <900ppm bromine, <900ppm chlorine (<1500ppm total Br + Cl) and <1000ppm antimony compounds.

Pin Assignments

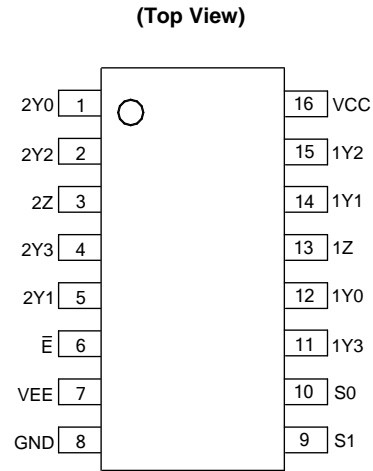

SOIC-16

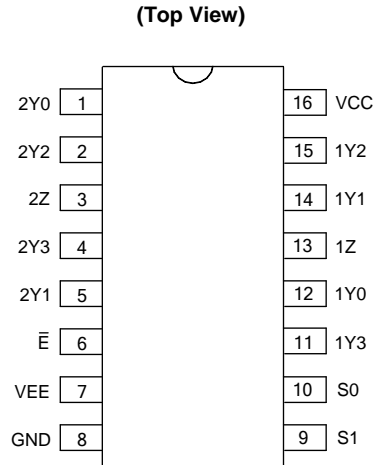

DIP-16

Typical Applications Circuit

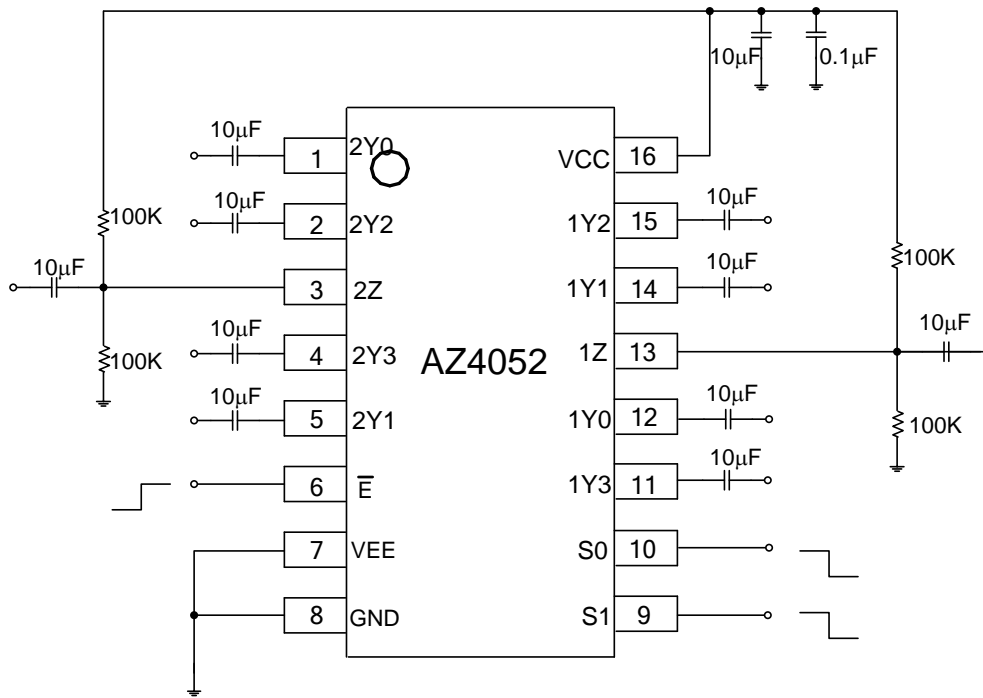

Pin Description

Pin Number	Pin Name	Function
1	2Y0	2CH signal input or output terminal 0
2	2Y2	2CH signal input or output terminal 2
3	2Z	2CH common signal input or output terminal
4	2Y3	2CH signal input or output terminal 3
5	2Y1	2CH signal input or output terminal 1
6	\bar{E}	Enable input (Active LOW)
7	VEE	Negative supply voltage
8	GND	Ground (0V)
9	S1	Select logic input terminal 1
10	S0	Select logic input terminal 0
11	1Y3	1CH signal input or output terminal 3
12	1Y0	1CH signal input or output terminal 0
13	1Z	1CH common signal input or output terminal
14	1Y1	1CH signal input or output terminal 1
15	1Y2	1CH signal input or output terminal 2
16	VCC	Positive supply voltage

Functional Block Diagram

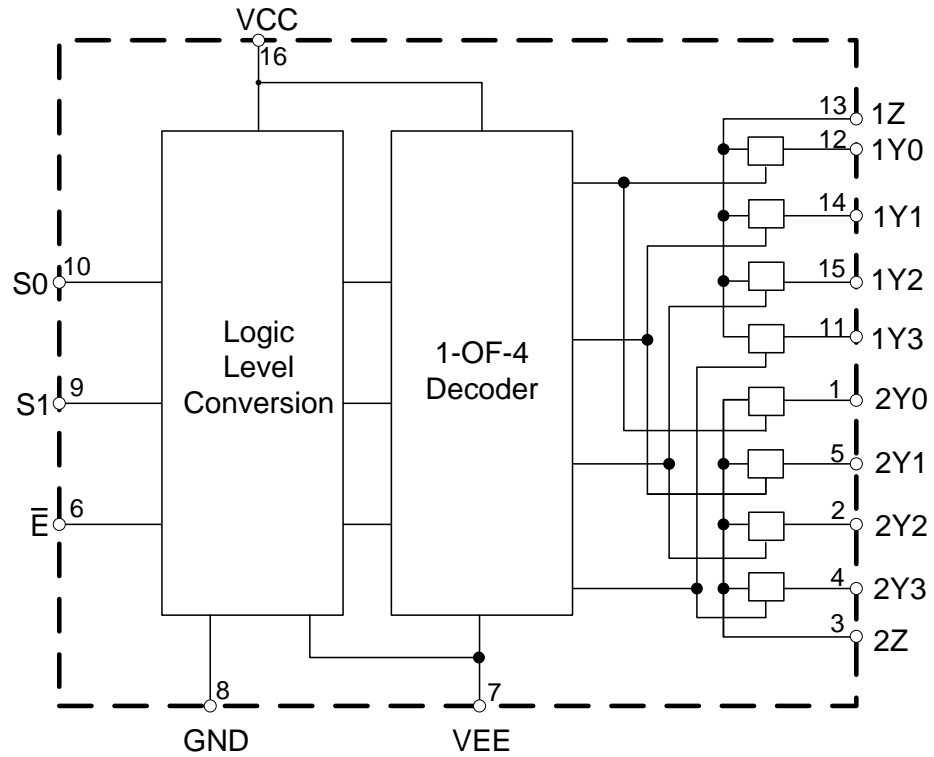

Schematic Diagram (One Switch)

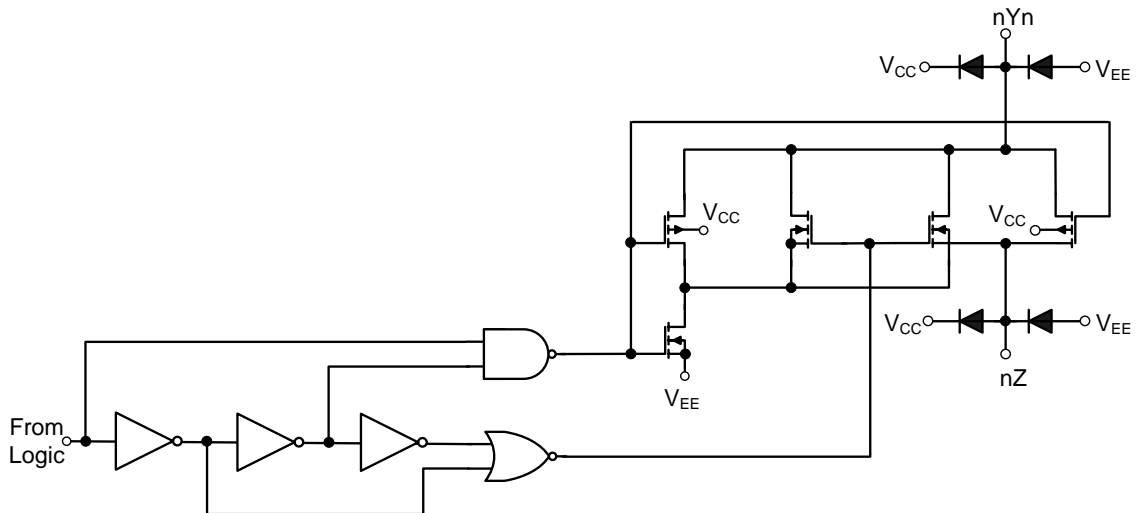

Absolute Maximum Ratings (Notes 4 & 5)

Symbol	Parameter	Condition	Rating	Unit
V_{CC}	Power Supply Voltage	–	-0.5 to 11.0	V
I_{IK}	Input Diode Current	$V_I < -0.5V, V_I > V_{CC}+0.5V$	20	mA
I_{SK}	Switch Diode Current	$V_S < -0.5V, V_S > V_{CC}+0.5V$	20	mA
I_S	Switch Current	$-0.5V < V_S < V_{CC}+0.5V$	25	mA
I_{EE}	V_{EE} Current	–	20	mA
I_{CC} I_{GND}	V_{CC} Current GND Current	–	50	mA
P_D	Power Dissipation	$T_A = -40^{\circ}C$ to $+85^{\circ}C$ (Note 6)	500	mW
T_{STG}	Storage Temperature Range	–	-65 to +150	$^{\circ}C$
T_J	Operating Junction Temperature Range	–	+150	$^{\circ}C$
P_S	Power Dissipation Per Switch	–	100	mW
–	ESD (Machine Model)	–	100	V
–	ESD (Human Body Model)	–	1,000	V

- Notes:
- Stresses greater than those listed under “Absolute Maximum Ratings” may cause permanent damage to the device. These are stress ratings only, and functional operation of the device at these or any other conditions beyond those indicated under “Recommended Operating Conditions” is not implied. Exposure to “Absolute Maximum Ratings” for extended periods may affect device reliability.
 - To avoid drawing V_{CC} current out of pins nZ, when switch current flows in pins nYn, the voltage drop across the bidirectional switch must not exceed 0.4V. If the switch current flows into pins nZ, no VCC current will flow out of pins nYn. In this case there is no limit for the voltage drop across the switch, but the voltages at pins nYn and nZ may not exceed V_{CC} or V_{EE} .
 - Above $+70^{\circ}C$ derate linearly with 12mW/K (DIP-16 package). Above $+70^{\circ}C$ derate linearly with 8mW/K (SOIC-16 package).

Recommended Operating Conditions

Symbol	Parameter	Condition	Min	Type	Max	Unit
V_{IN}	Supply Voltage	V_{CC} -GND	3.0	–	10	V
		V_{CC} - V_{EE}	3.0	–	10	
V_I	Logic Input Voltage	–	V_{EE}	–	V_{CC}	V
V_{IS}/V_{OS}	Switch Signal Input/Output Voltage	–	V_{EE}	–	V_{CC}	V
T_A	Operating Ambient Temperature Range	–	-40	–	+85	$^{\circ}C$
t_r, t_f	Input Rise and Fall Time	$V_{CC} = 5.0V$	–	6.0	400	ns
		$V_{CC} = 10V$	–	6.0	250	

Electrical Characteristics

DC Characteristics

V_{IS} is the input voltage at pins nYn or nZ, whichever is assigned as an input; V_{OS} is the output voltage at pins nZ or nYn, whichever is assigned as an output, voltages are referenced to GND (Ground = 0V).

Symbol	Parameter	Conditions			Min	Typ	Max	Unit	
		Other	V _{CC} (V)	V _{EE} (V)					
V _{IH}	High-level Input Voltage	-	5.0	-	2.8	-	-	V	
			10	-	6.0	-	-		
V _{IL}	Low-level Input Voltage	-	5.0	-	-	-	1.5	V	
			10	-	-	-	3.0		
I _{LI}	Input Leakage Current	V _I = V _{CC} or GND	5.0	0	-	-	±1.0	µA	
			10	0	-	-	±1.0	µA	
I _S (Off)	Analog Switch Off-state Current	V _I = V _{IH} or V _{IL} , V _S = V _{CC} -V _{EE} (Figure 1)	5.0	-	-	-	±1.0	µA	
			Per Channel	10	0	-	-	±1.0	µA
			All Channels	10	0	-	-	±2.0	µA
I _S (On)	Analog Switch On-state Current	V _I = V _{IH} or V _{IL} , V _S = V _{CC} -V _{EE} (Figure 2)	10	0	-	-	±2.0	µA	
I _{CC}	Quiescent Supply Current	V _I = V _{CC} or GND, V _{IS} = V _{EE} or V _{CC} , V _{OS} = V _{CC} or V _{EE}	5.0	0	-	50	160	µA	
			10	0	-	100	320	µA	

Resistance R_{ON}

V_{IS} is the input voltage at pins nYn or nZ, which is assigned as an input ((Note 7) see figure 3)

Symbol	Parameter	Conditions				Min	Typ	Max	Unit
		Other	V _{CC} (V)	V _{EE} (V)	I _S (µA)				
R _{ON} (Peak)	On-resistance (Peak)	V _{IS} = V _{CC} to V _{EE} , V _I = V _{IH} or V _{IL}	5.0	0	1,000	-	73	180	Ω
			10	0	1,000	-	47	120	Ω
R _{ON} (Rail)	On-resistance (Rail)	V _{IS} = V _{EE} , V _I = V _{IH} or V _{IL}	5.0	0	1,000	-	55	130	Ω
			10	0	1,000	-	40	100	Ω
		V _{IS} = V _{CC} , V _I = V _{IH} or V _{IL}	5.0	0	1,000	-	61	150	Ω
			10	0	1,000	-	45	110	Ω
R _{ON}	Maximum On-resistance Difference Between Any Two Channels	V _{IS} = V _{CC} to V _{EE} , V _I = V _{IH} or V _{IL}	5.0	0	-	-	5	-	Ω
			10	0	-	-	6	-	Ω

Note: 7. When supply voltages (V_{CC}-V_{EE}) near 2.0V the analog switch On-resistance becomes extremely non-linear. When using a supply of 2V, it is recommended to use these devices only for transmitting digital signals.

Electrical Characteristics (continued)

AC Characteristics

GND = 0V, $t_r = t_f = 6\text{ns}$, $C_L = 50\text{pF}$

Symbol	Parameter	Conditions			Min	Typ	Max	Unit
		Other	V _{CC} (V)	V _{EE} (V)				
t _{PHL} /t _{PLH}	Propagation Delay V _{IS} to V _{OS}	R _L = ∞ (Figure 20)	5.0	0	-	15	25	ns
			5.0	-5.0	-	12	25	ns
t _{PZH} /t _{PZL}	Turn-on Time \bar{E} , Sn to V _{OS}	R _L = 1kΩ (Figure 21 and 22)	5.0	0	-	38	81	ns
			5.0	-5.0	-	26	81	ns
t _{PHZ} /t _{PLZ}	Turn-off Time \bar{E} , Sn to V _{OS}	R _L = 1kΩ (Figure 21 and 22)	5.0	0	-	27	63	ns
			5.0	-5.0	-	22	48	ns

Recommended conditions and typical values, GND = 0V, T_A = +25°C, C_L = 50pF. V_{IS} is the input voltage at pins nYn or nZ, whichever is assigned as an input. V_{OS} is the output voltage at pins nYn or nZ, whichever is assigned as an output.

Symbol	Parameter	Conditions				Min	Typ	Max	Unit
		Other	V _{IS} (p-p) (V)	V _{CC} (V)	V _{EE} (V)				
d _{SIN}	Sine-wave Distortion	f = 1kHz, R _L = 10kΩ (Figure 4)	0.5	5.0	0	-	0.008	-	%
			1.5	10	0	-	0.003	-	%
		f = 10kHz, R _L = 10kΩ (Figure 4)	0.5	5.0	0	-	0.008	-	%
			1.5	10	0	-	0.003	-	%
α _{OFF} (Feedthrough)	Switch OFF Signal Feed-through	R _L = 10kΩ, f = 1MHz (Figure 5), V _{IS} = 1V _{RMS}	-	5.0	0	-	-50	-	dB
			-	5.0	-5.0	-	-50	-	dB
α _{CT(S)}	Crosstalk Between Two Channels	R _L = 10kΩ, f = 1kHz (Figure 6), V _{IS} = 1V _{RMS}	-	5.0	0	-	-120	-	dB
			-	5.0	-5.0	-	-120	-	dB
	Crosstalk Between Two Switches / Multiplexers	R _L = 10kΩ, f = 1kHz (Figure 6), V _{IS} = 1V _{RMS}	-	5.0	0	-	-60	-	dB
			-	5.0	-5.0	-	-60	-	dB
V _{CT(P-P)}	Crosstalk Voltage Between Control and Any Switch (Peak-to-peak Value)	R _L = 10kΩ, f = 1MHz, \bar{E} or Sn, Square-wave Between V _{CC} and GND, $t_r = t_f = 6\text{ns}$ (Figure 7)	-	5.0	0	-	110	-	mV
f _{MAX}	Frequency Response (-3dB)	R _L = 10kΩ (Figure 4)	-	5.0	0	-	70	-	MHz
			-	5.0	-5.0	-	70	-	MHz
V _{NOISE}	Output Noise Voltage	A-weighted	-	5.0	0	-	6.0	-	μV _{RMS}

Typical Test Circuit

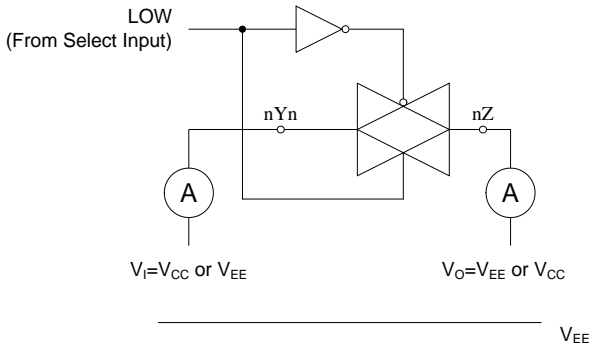

Figure 1. Test Circuit for Measuring OFF-state Current

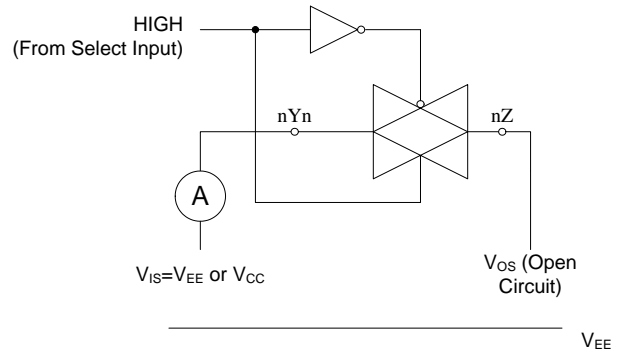

Figure 2. Test Circuit for Measuring ON-state Current

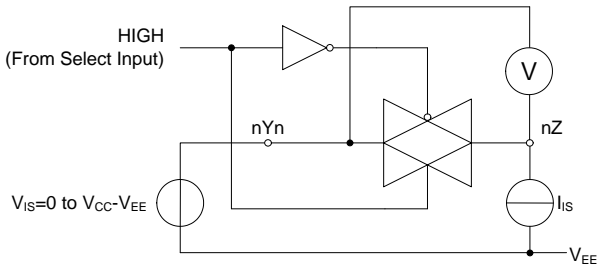

Figure 3. Test Circuit for Measuring Ron

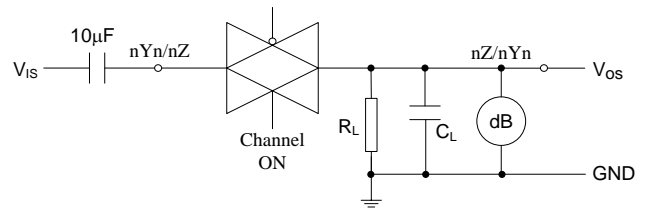

Figure 4. Test Circuit for Measuring Sine-wave Distortion and Minimum Frequency Response

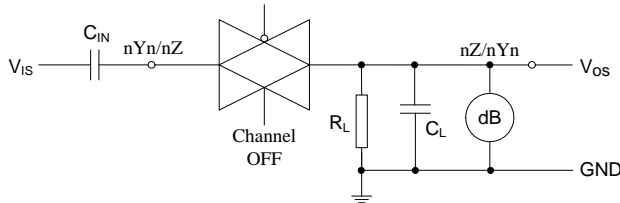
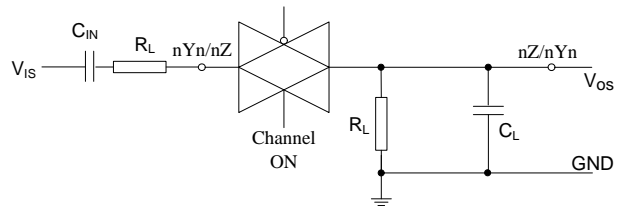
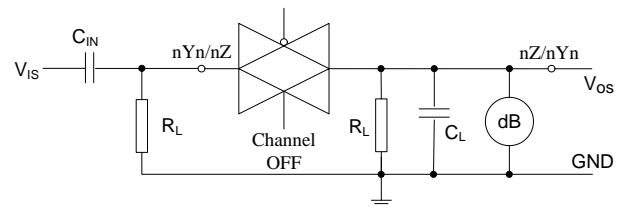

Figure 5. Test Circuit for Measuring Switch Off Signal Feed-through



(a) Channel ON Condition



(b) Channel OFF Condition

Figure 6. Test Circuits for Measuring Crosstalk between Any Two Switches/Multiplexers

Typical Test Circuit (continued)

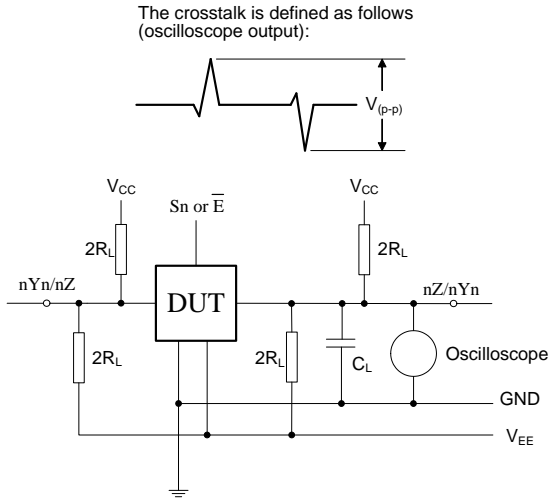

Figure 7. Test Circuit for Measuring Crosstalk Performance

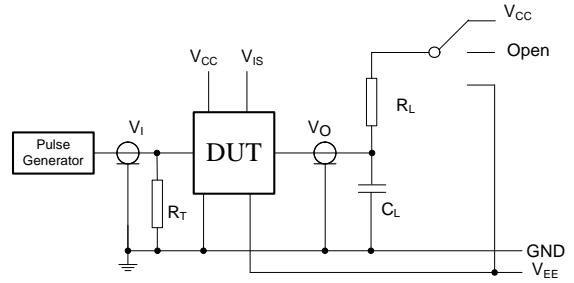

Figure 8. Test Circuit for Measuring AC between Control and Any Switch

Performance Characteristics

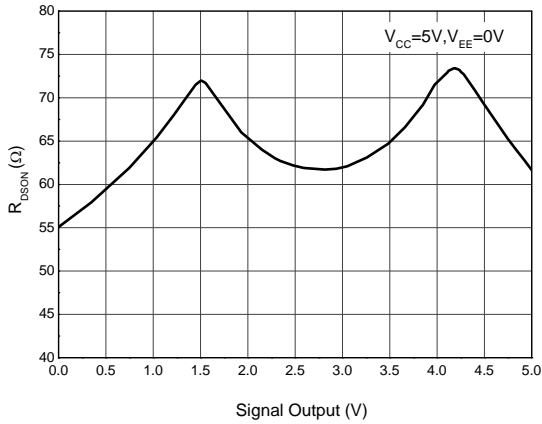

Figure 9. RDSON vs. Signal Output

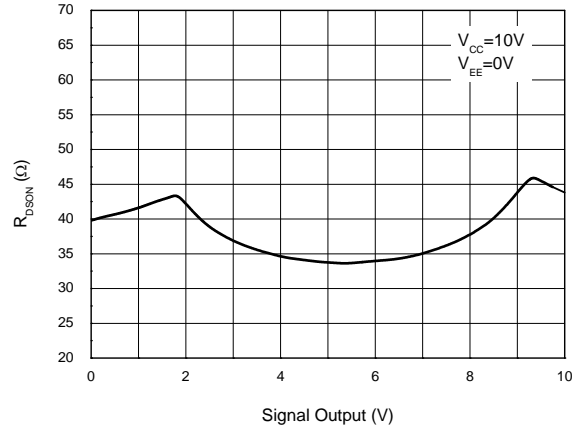

Figure 10. RDSON vs. Signal Output

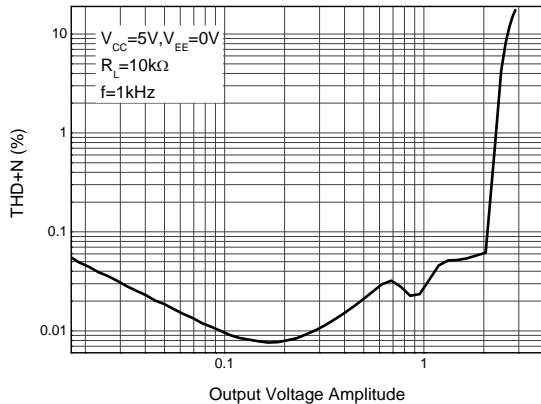

Figure 11. THD+N vs. Output Voltage Amplitude

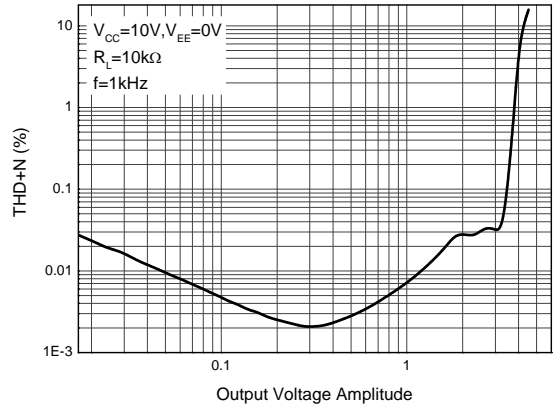

Figure 12. THD+N vs. Output Voltage Amplitude

Performance Characteristics (continued)

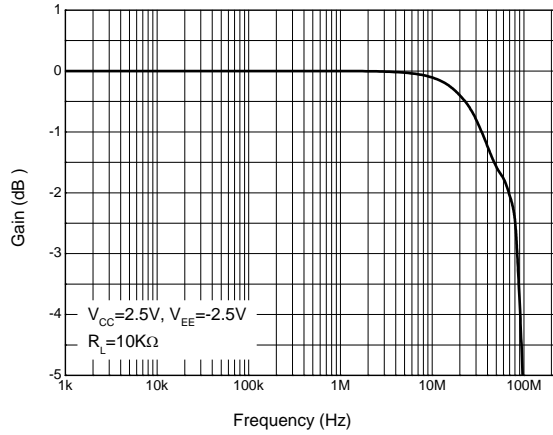

Figure 13. Frequency Response

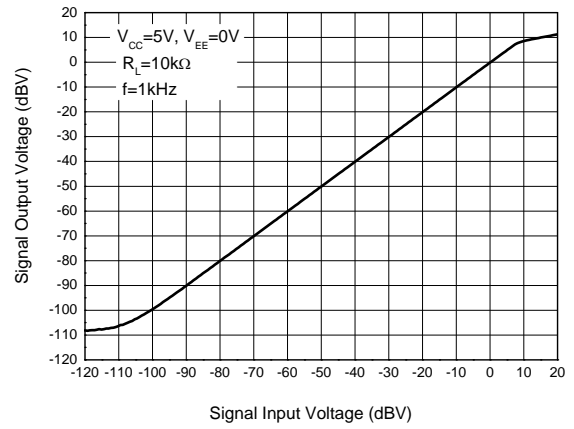

Figure 14. Linear Range

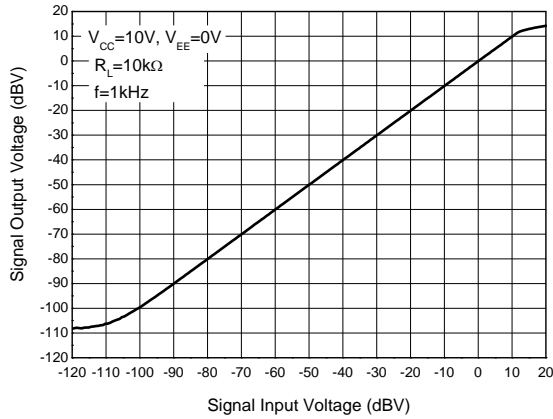

Figure 15. Linear Range

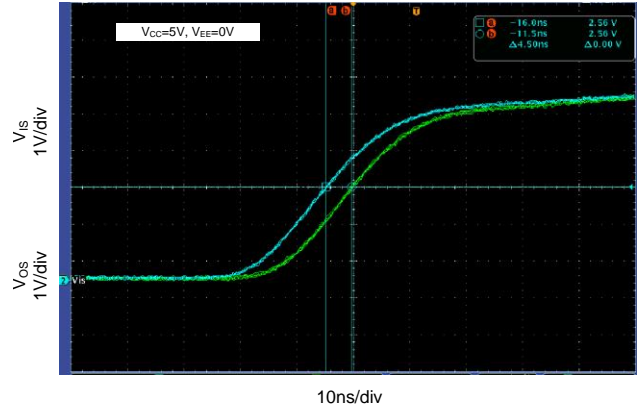

Figure 16. Propagation Delay

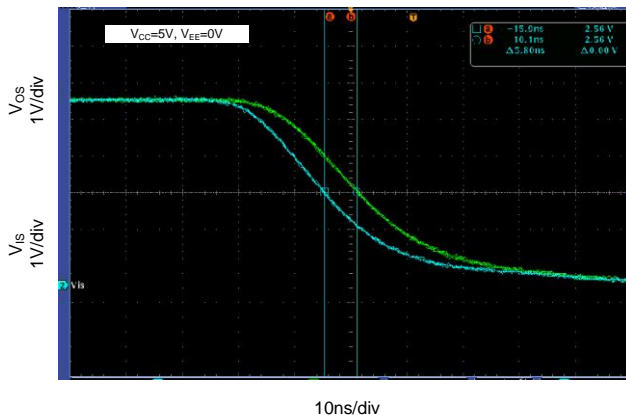

Figure 17. Propagation Delay

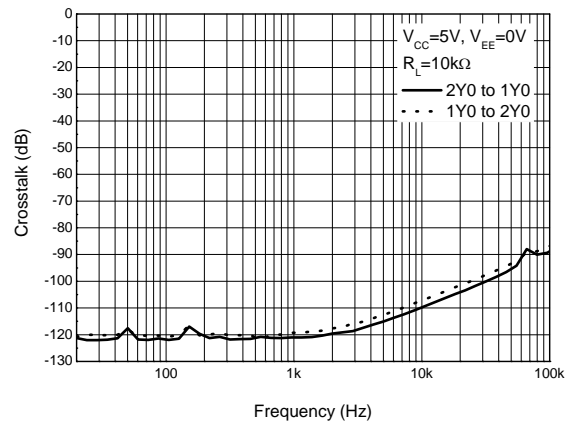

Figure 18. Crosstalk vs. Frequency

Performance Characteristics (cont.)

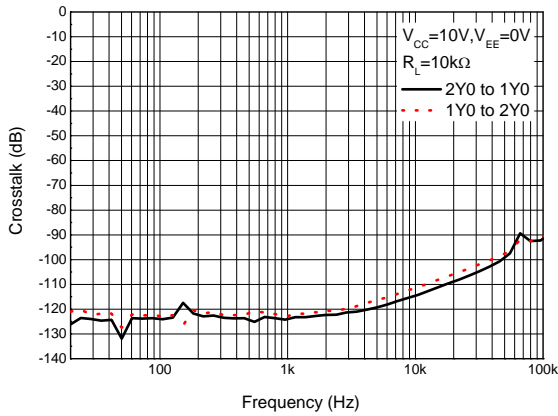

Figure 19. Crosstalk vs. Frequency

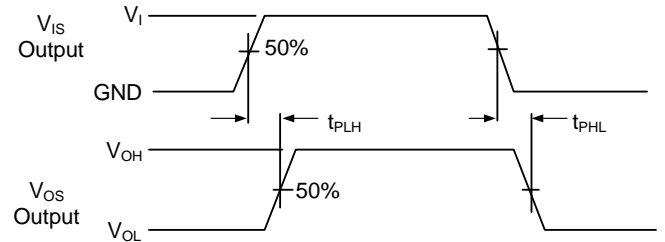

Figure 20. Waveforms Showing the Input (VIS) to Output (VOS) Propagation Delays

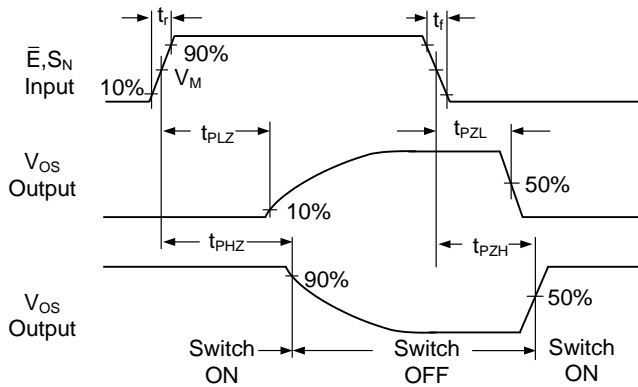

Figure 21. Waveforms Showing the Turn-on and Turn-off Times (VM = 50%, VI = GND to VCC)

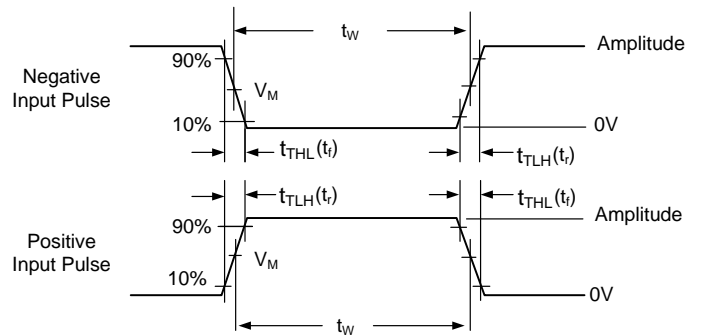
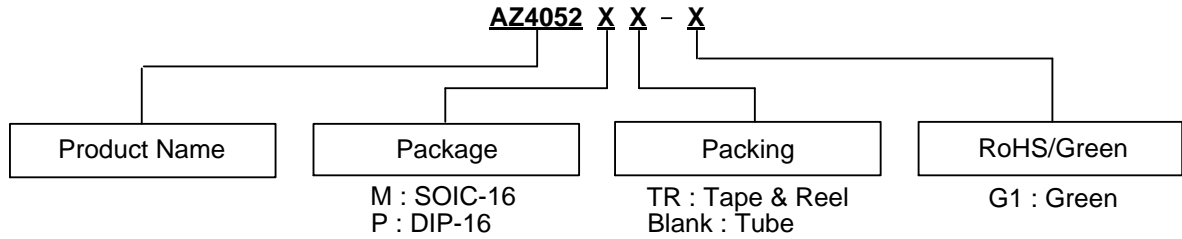

Figure 22. Input Pulse Definitions

Amplitude	VM	tr and tf	
		Fmax Pulse Width	Other
VCC	50%	<2ns	6ns

Ordering Information



Package	Temperature Range	Part Number	Marking ID	Packing
SOIC-16	-40 to +85°C	AZ4052M-G1	AZ4052M-G1	25/Tube
		AZ4052MTR-G1	AZ4052M-G1	4,000/13"/ Tape & Reel
DIP-16	-40 to +85°C	AZ4052P-G1	AZ4052P-G1	25/Tube

DIP16 Marking Information:

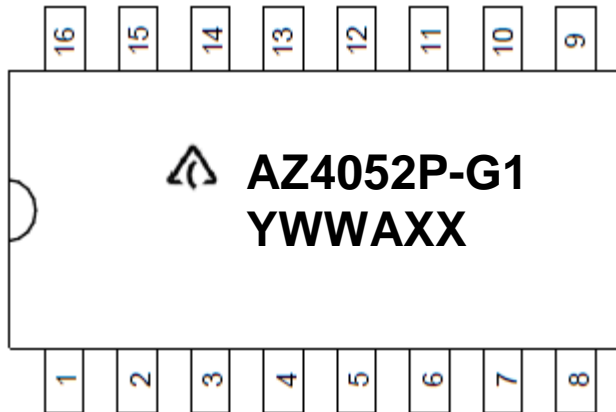

First line: Logo and Marking ID
 Second line: Date Code
 Y: year
 WW: work week of molding
 A: assembly house code
 XX: 7th and 8th digits of Batch Number

SOIC16 Marking Information:

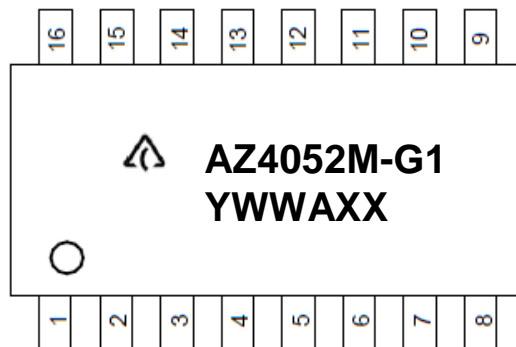

First line: Logo and Marking ID
 Second line: Date Code
 Y: year
 WW: work week of molding
 A: assembly house code
 XX: 7th and 8th digits of Batch Number

Package Outline Dimensions (All dimensions in mm(inch).)

Please see <http://www.diodes.com/package-outlines.html> for the latest version.

(1) Package Type: SOIC-16

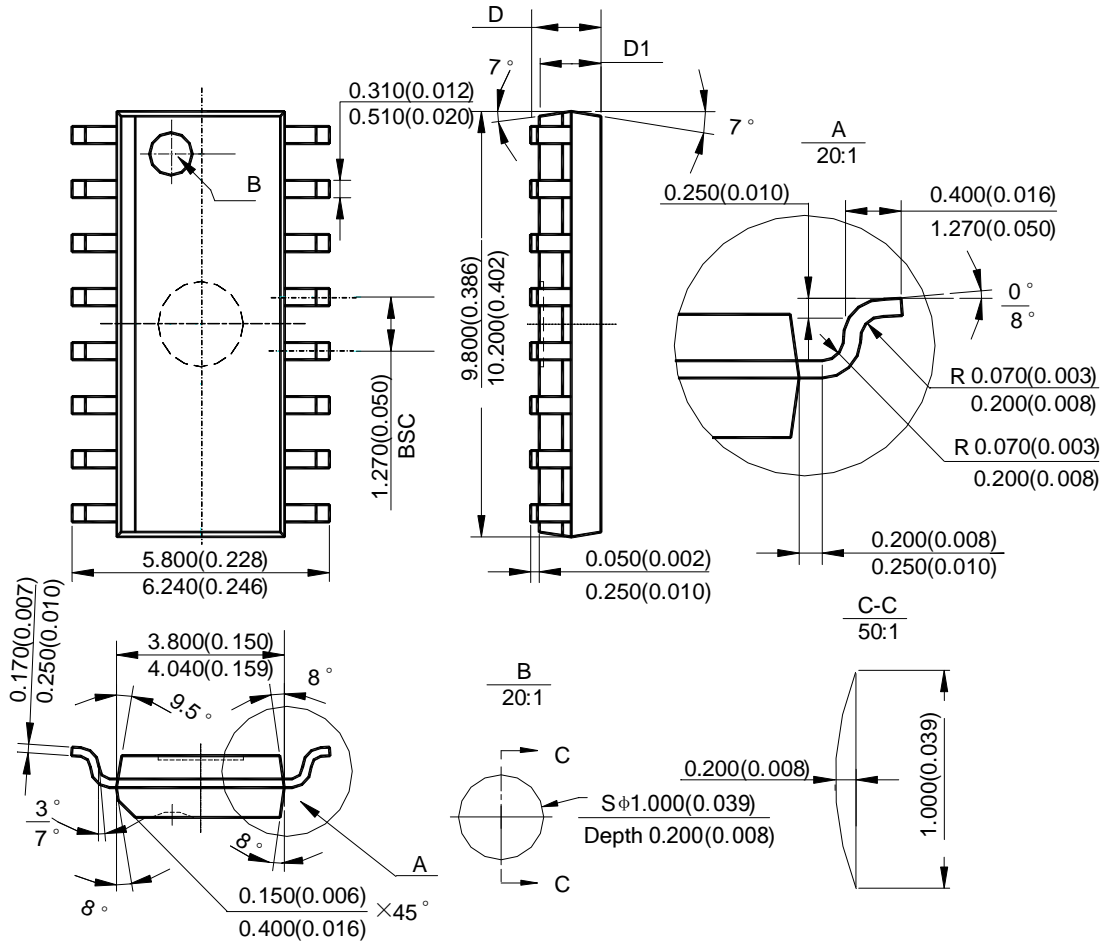

Note: Eject hole, oriented hole and mold mark is optional.

Symbol	D				D1			
	min(mm)	max(mm)	min(inch)	max(inch)	min(mm)	max(mm)	min(inch)	max(inch)
Option1	1.350	1.750	0.053	0.069	1.250	1.650	0.049	0.065
Option2	-	1.260	-	0.050	1.020	-	0.040	-

Package Outline Dimensions (continued... All dimensions in mm(inch).)

Please see <http://www.diodes.com/package-outlines.html> for the latest version.

(2) Package Type: DIP-16

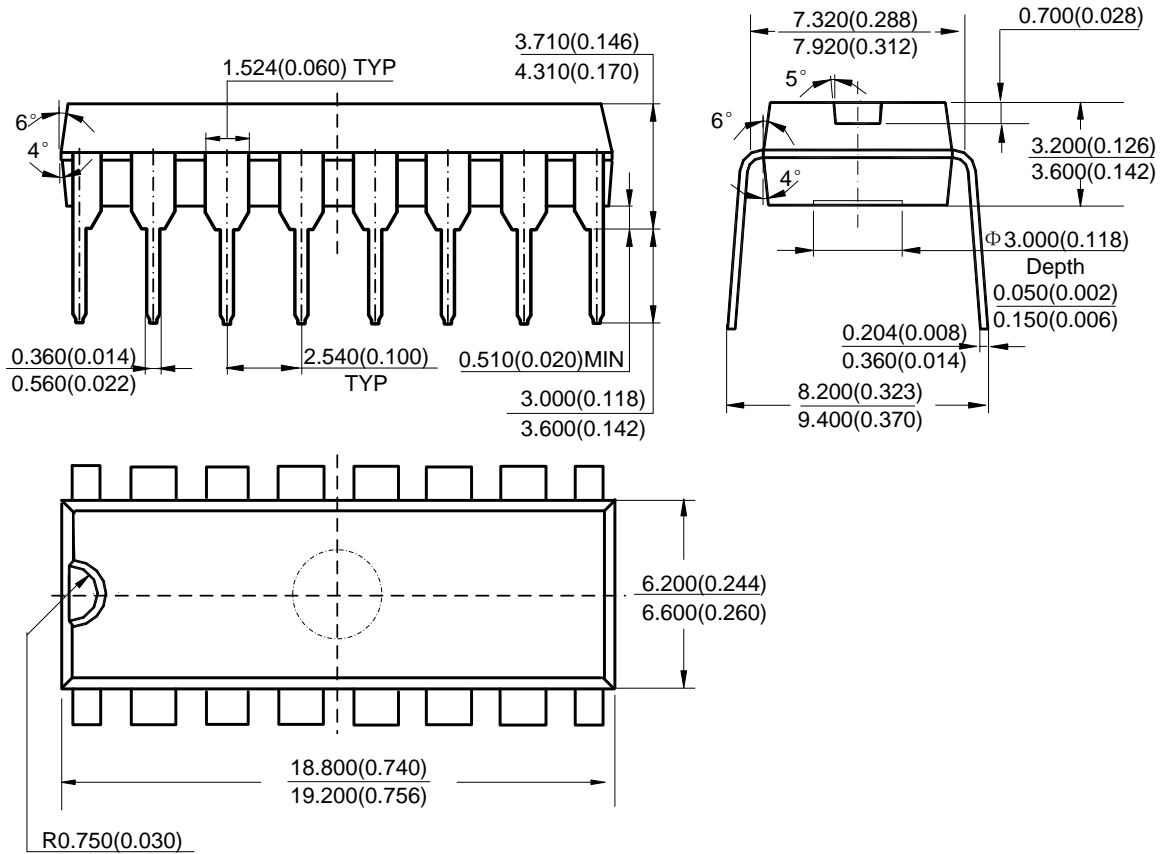

Note: Eject hole, oriented hole and mold mark is optional.

Suggested Pad Layout

Please see <http://www.diodes.com/package-outlines.html> for the latest version.

(1) Package Type: SOIC-16

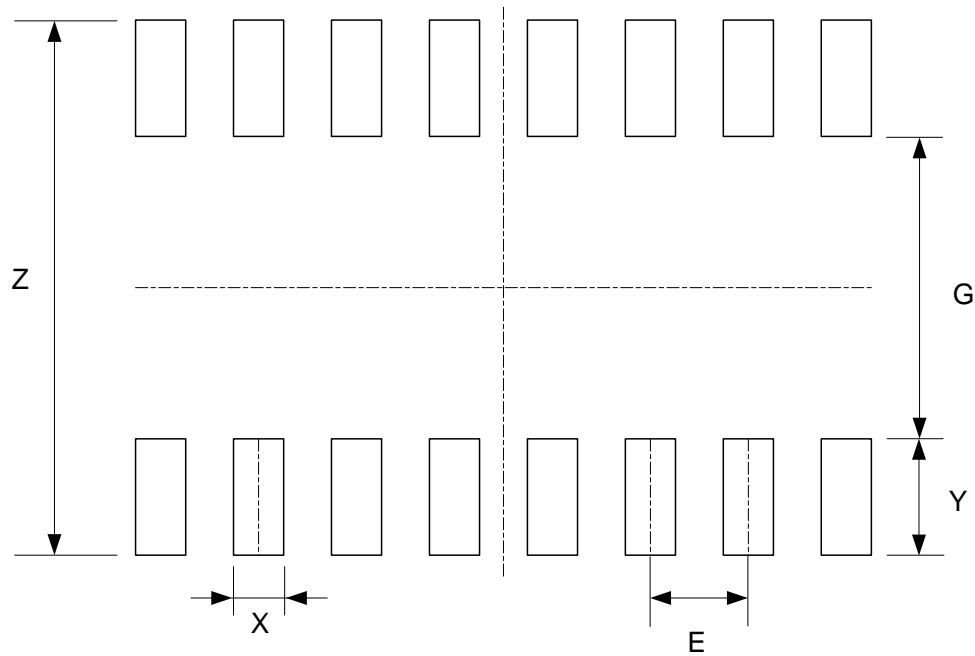

Dimensions	Z (mm)/(inch)	G (mm)/(inch)	X (mm)/(inch)	Y (mm)/(inch)	E (mm)/(inch)
Value	6.900/0.272	3.900/0.154	0.650/0.026	1.500/0.059	1.270/0.050

IMPORTANT NOTICE

DIODES INCORPORATED MAKES NO WARRANTY OF ANY KIND, EXPRESS OR IMPLIED, WITH REGARDS TO THIS DOCUMENT, INCLUDING, BUT NOT LIMITED TO, THE IMPLIED WARRANTIES OF MERCHANTABILITY AND FITNESS FOR A PARTICULAR PURPOSE (AND THEIR EQUIVALENTS UNDER THE LAWS OF ANY JURISDICTION).

Diodes Incorporated and its subsidiaries reserve the right to make modifications, enhancements, improvements, corrections or other changes without further notice to this document and any product described herein. Diodes Incorporated does not assume any liability arising out of the application or use of this document or any product described herein; neither does Diodes Incorporated convey any license under its patent or trademark rights, nor the rights of others. Any Customer or user of this document or products described herein in such applications shall assume all risks of such use and will agree to hold Diodes Incorporated and all the companies whose products are represented on Diodes Incorporated website, harmless against all damages.

Diodes Incorporated does not warrant or accept any liability whatsoever in respect of any products purchased through unauthorized sales channel. Should Customers purchase or use Diodes Incorporated products for any unintended or unauthorized application, Customers shall indemnify and hold Diodes Incorporated and its representatives harmless against all claims, damages, expenses, and attorney fees arising out of, directly or indirectly, any claim of personal injury or death associated with such unintended or unauthorized application.

Products described herein may be covered by one or more United States, international or foreign patents pending. Product names and markings noted herein may also be covered by one or more United States, international or foreign trademarks.

This document is written in English but may be translated into multiple languages for reference. Only the English version of this document is the final and determinative format released by Diodes Incorporated.

LIFE SUPPORT

Diodes Incorporated products are specifically not authorized for use as critical components in life support devices or systems without the express written approval of the Chief Executive Officer of Diodes Incorporated. As used herein:

A. Life support devices or systems are devices or systems which:

1. are intended to implant into the body, or
2. support or sustain life and whose failure to perform when properly used in accordance with instructions for use provided in the labeling can be reasonably expected to result in significant injury to the user.

B. A critical component is any component in a life support device or system whose failure to perform can be reasonably expected to cause the failure of the life support device or to affect its safety or effectiveness.

Customers represent that they have all necessary expertise in the safety and regulatory ramifications of their life support devices or systems, and acknowledge and agree that they are solely responsible for all legal, regulatory and safety-related requirements concerning their products and any use of Diodes Incorporated products in such safety-critical, life support devices or systems, notwithstanding any devices- or systems-related information or support that may be provided by Diodes Incorporated. Further, Customers must fully indemnify Diodes Incorporated and its representatives against any damages arising out of the use of Diodes Incorporated products in such safety-critical, life support devices or systems.

Copyright © 2016, Diodes Incorporated

www.diodes.com

Looking for pricing, stock, or lifecycle information?

Click below to explore more details on WIN SOURCE:

 [View AZ4052MTR-G1 on WIN SOURCE](#)

 [Diodes Incorporated](#) Information

Optimize Your Supply Chain with WIN SOURCE Solutions

-  Global Sourcing Solution
-  Obsolete Management
-  Cost Control Management
-  Shortage Management
-  Alternative Solution
-  Excess Inventory Management