



**THE DATASHEET OF
AZ431AZ-AE1**



Description

The AZ431-A is a three-terminal adjustable shunt regulator with guaranteed thermal stability over a full operation range. It features sharp turn-on characteristics, low temperature coefficient and low output impedance, which make it ideal substitute for Zener diode in applications such as switching power supply, charger and other adjustable regulators.

The output voltage of AZ431-A can be set to any value between V_{REF} (2.5V) and the corresponding maximum cathode voltage (36V).

The AZ431-A precision reference is offered in two voltage tolerance: 0.4% and 0.8%.

This IC is available in 3 packages: TO92 (Bulk or Ammo Packing), SOT23 and SOT89.

Features

- Programmable Precise Output Voltage from 2.5V to 36V
- High Stability under Capacitive Load
- Low Temperature Deviation: 4.5mV Typical
- Low Equivalent Full-range Temperature Coefficient with 20PPM/°C Typical
- Sink Current Capacity from 1mA to 100mA
- Low Output Noise
- Wide Operating Range of -40 to +125°C
- Lead-Free Packages: TO92, SOT23, SOT89
 - **Totally Lead-Free; RoHS Compliant (Notes 1 & 2)**
- Lead-Free Packages, Available in "Green" Molding Compound: TO92, SOT23
 - **Totally Lead-Free & Fully RoHS Compliant (Notes 1 & 2)**
 - **Halogen and Antimony Free. "Green" Device (Note 3)**

Applications

- Charger
- Voltage Adapter
- Switching Power Supply
- Graphic Card
- Precision Voltage Reference

Pin Assignments

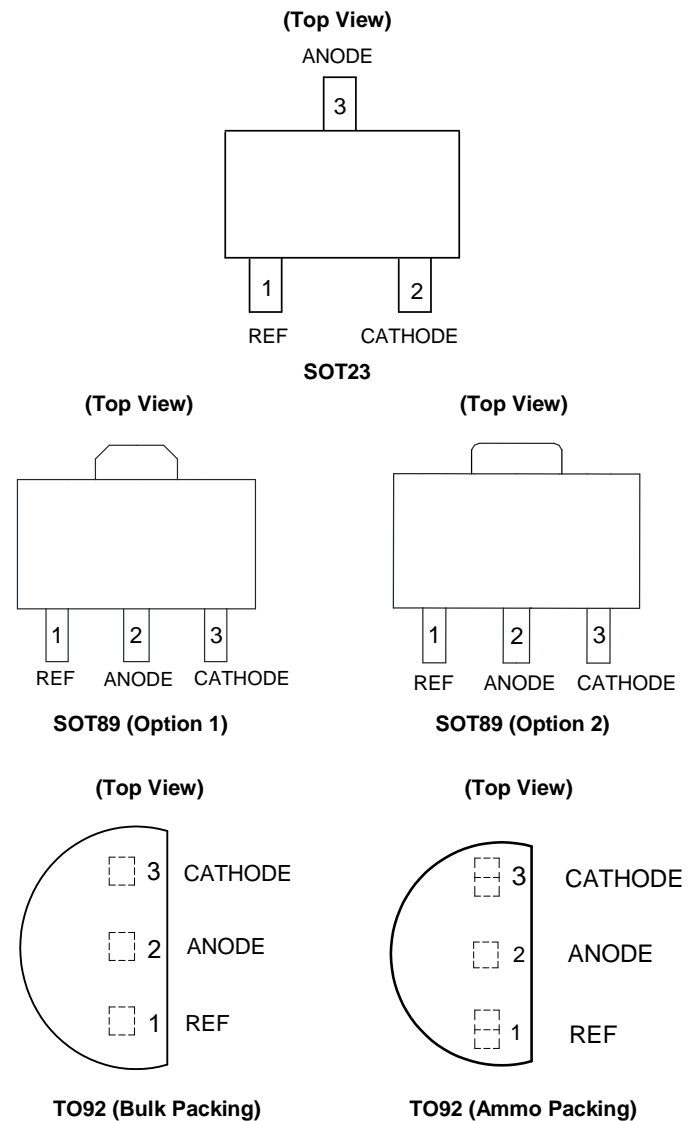

- Notes:
1. No purposely added lead. Fully EU Directive 2002/95/EC (RoHS), 2011/65/EU (RoHS 2) & 2015/863/EU (RoHS 3) compliant.
 2. See <https://www.diodes.com/quality/lead-free/> for more information about Diodes Incorporated's definitions of Halogen- and Antimony-free, "Green" and Lead-free.
 3. Halogen- and Antimony-free "Green" products are defined as those which contain <900ppm bromine, <900ppm chlorine (<1500ppm total Br + Cl) and <1000ppm antimony compounds.

Typical Applications Circuit

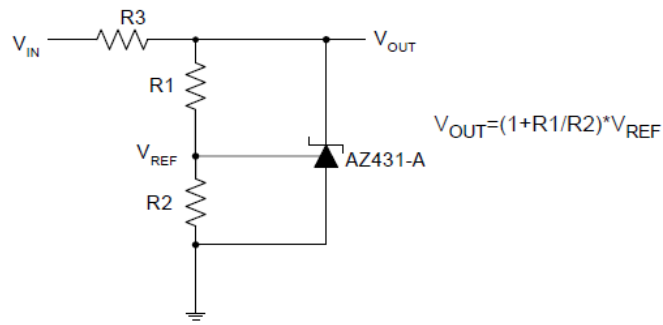

Shunt Regulator

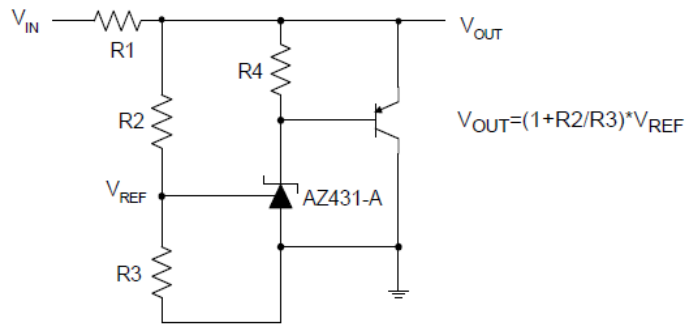

High Current Shunt Regulator

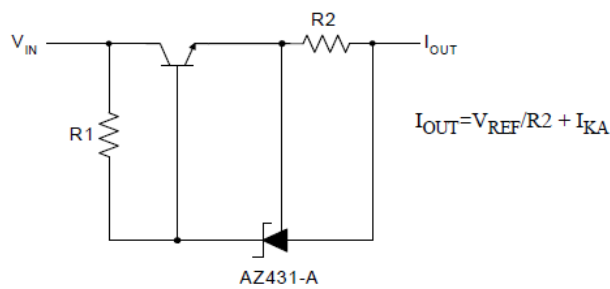

Current Source or Current Limit

Typical Applications Circuit (Cont.)

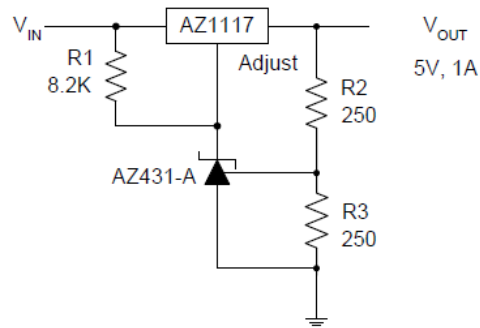

Precision 5V 1A Regulator

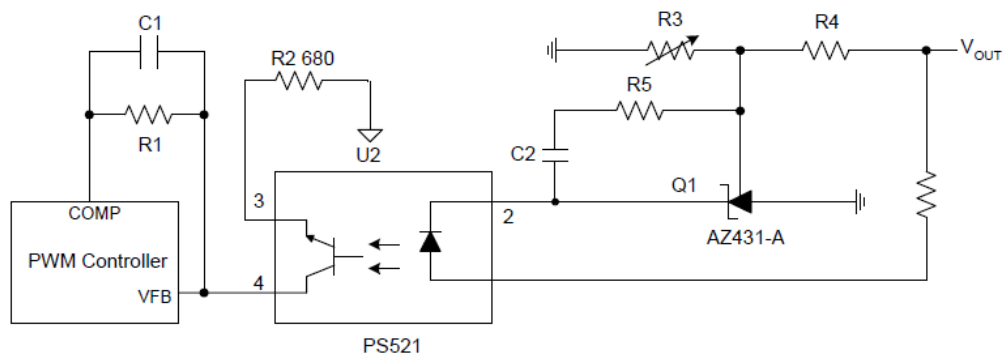

PWM Converter with Reference

Functional Block Diagram

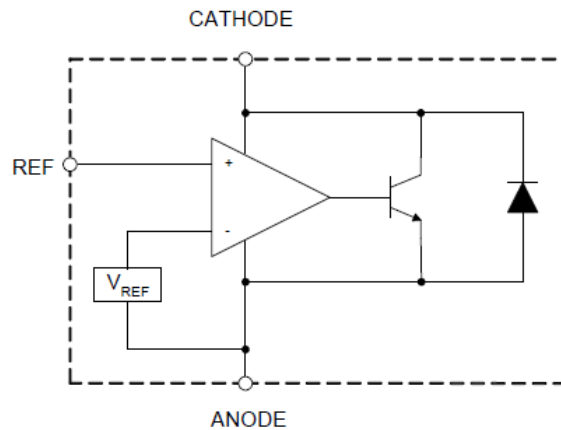

Absolute Maximum Ratings (Note 4)

Symbol	Parameter		Rating	Unit
V_{KA}	Cathode Voltage		40	V
I_{KA}	Cathode Current Range (Continuous)		-100 to 150	mA
I_{REF}	Reference Input Current Range		10	mA
P_D	Power Dissipation		Z, R Package: 770	mW
			N Package: 370	
θ_{JA}	Thermal Resistance (Junction to Ambient)	SOT23	380	°C/W
		TO92	165	
		SOT89	165	
T_J	Junction Temperature		+150	°C
T_{STG}	Storage Temperature Range		-65 to +150	°C
ESD	ESD (Human Body Model)		2000	V

Note 4: Stresses greater than those listed under "Absolute Maximum Ratings" may cause permanent damage to the device. These are stress ratings only, and functional operation of the device at these or any other conditions beyond those indicated under "Recommended Operating Conditions" is not implied. Exposure to "Absolute Maximum Ratings" for extended periods may affect device reliability.

Recommended Operating Conditions

Symbol	Parameter	Min	Max	Unit
V_{KA}	Cathode Voltage	V_{REF}	36	V
I_{KA}	Cathode Current	1.0	100	mA
T_A	Operating Ambient Temperature Range	-40	+125	°C

Electrical Characteristics (@ $T_A = +25^\circ\text{C}$, unless otherwise specified.)

Symbol	Test Circuit	Parameter	Conditions	Min	Typ	Max	Unit	
V_{REF}	4	Reference Voltage	$V_{KA} = V_{REF}, I_{KA} = 10\text{mA}$	0.4%	2.490	2.500	2.510	V
				0.8%	2.480	2.500	2.520	
ΔV_{REF}	4	Deviation of Reference Voltage Over Full Temperature Range	$V_{KA} = V_{REF}, I_{KA} = 10\text{mA}$	0 to $+70^\circ\text{C}$	—	4.5	8	mV
				-40 to $+85^\circ\text{C}$	—	4.5	10	
				-40 to $+125^\circ\text{C}$	—	4.5	16	
$\frac{\Delta V_{REF}}{\Delta V_{KA}}$	5	Ratio of Change in Reference Voltage to the Change in Cathode Voltage	$I_{KA} = 10\text{mA}$	$\Delta V_{KA} = 10\text{V to } V_{REF}$	—	-1.0	-2.7	mV/V
				$\Delta V_{KA} = 36\text{V to } 10\text{V}$	—	-0.5	-2.0	
I_{REF}	5	Reference Current	$I_{KA} = 10\text{mA}, R1 = 10\text{k}\Omega, R2 = \infty$	—	0.7	4	μA	
ΔI_{REF}	5	Deviation of Reference Current Over Full Temperature Range	$I_{KA} = 10\text{mA}, R1 = 10\text{k}\Omega, R2 = \infty, T_A = -40$ to $+125^\circ\text{C}$	—	0.4	1.2	μA	
$I_{KA}(\text{Min})$	4	Minimum Cathode Current for Regulation	$V_{KA} = V_{REF}$	—	0.4	1.0	mA	
$I_{KA}(\text{Off})$	6	Off-state Cathode Current	$V_{KA} = 36\text{V}, V_{REF} = 0$	—	0.05	1.0	μA	
Z_{KA}	4	Dynamic Impedance	$V_{KA} = V_{REF}, I_{KA} = 1$ to $100\text{mA}, f \leq 1.0\text{kHz}$	—	0.15	0.5	Ω	
θ_{JC}	—	Thermal Resistance	SOT23	—	135.48	—	$^\circ\text{C/W}$	
	—		TO92	—	81.63	—		
	—		SOT89	—	29.80	—		

Electrical Characteristics (Cont.)

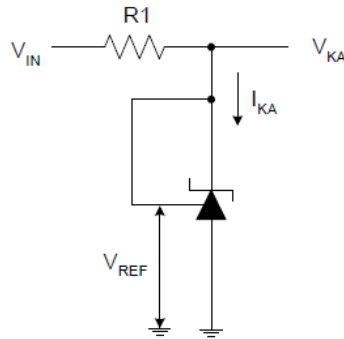

Test Circuit 4 for $V_{KA} = V_{REF}$

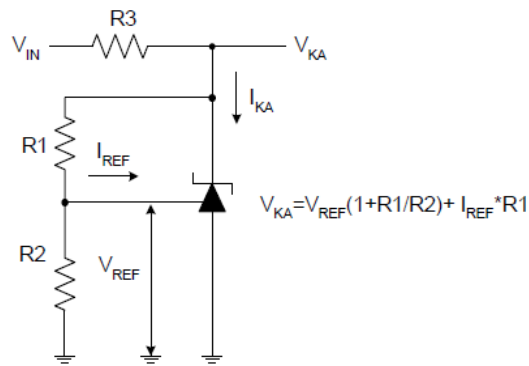

Test Circuit 5 for $V_{KA} > V_{REF}$

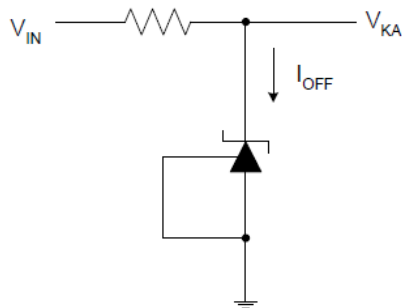

Test Circuit 6 for I_{OFF}

Performance Characteristics

Reference Voltage vs. Ambient Temperature

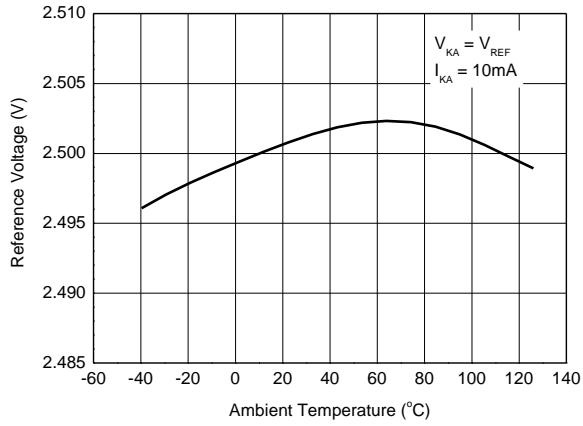

Reference Current vs. Ambient Temperature

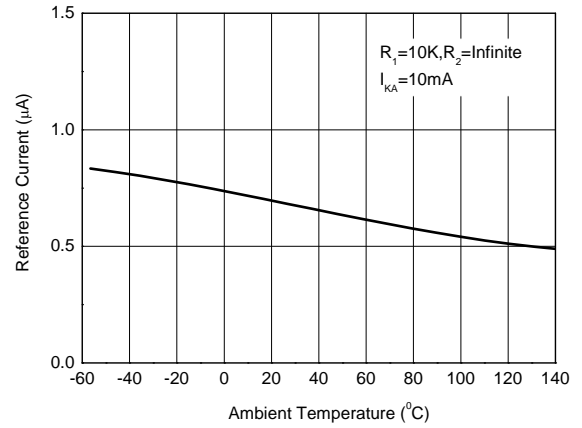

Cathode Current vs. Cathode Voltage

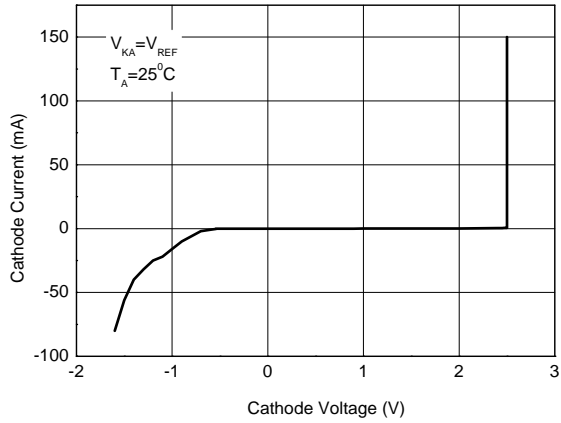

Cathode Current vs. Cathode Voltage

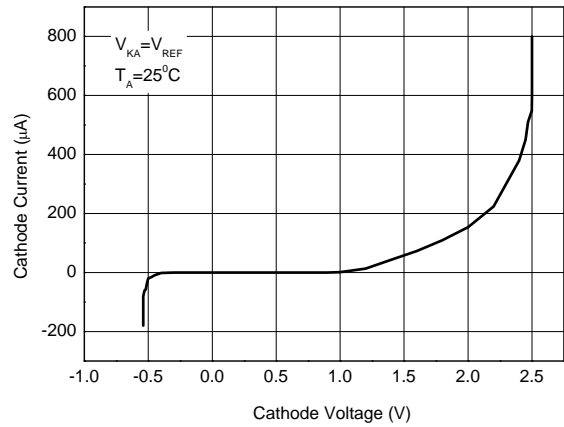

Off-State Cathode Current vs. Ambient Temperature

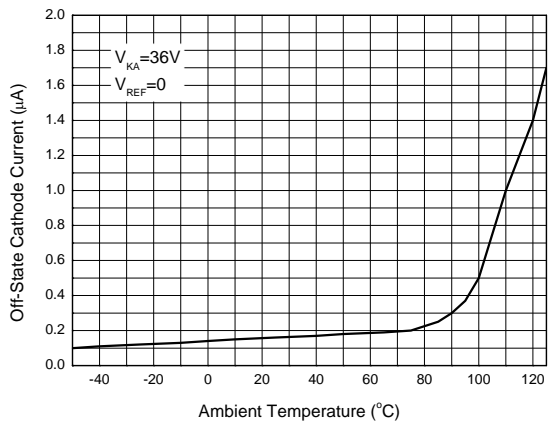

Ratio of Delta Reference Voltage to the Ratio of Delta Cathode Voltage

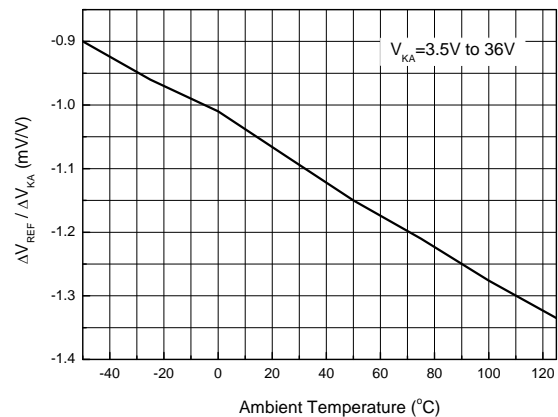

Performance Characteristics (Cont.)

Small Signal Voltage Gain vs. Frequency

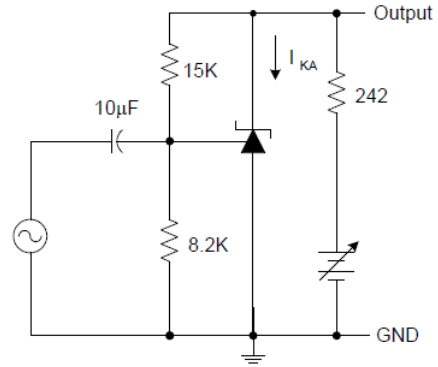
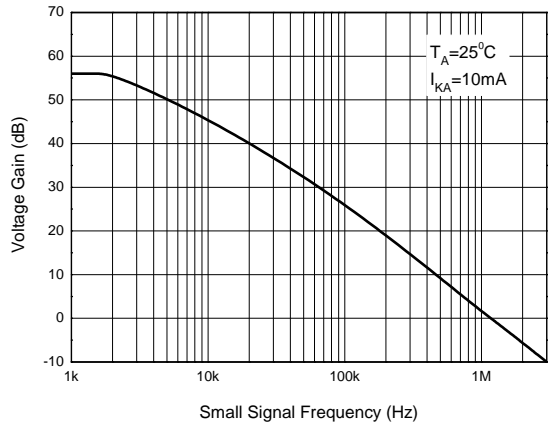

Reference Impedance vs. Frequency

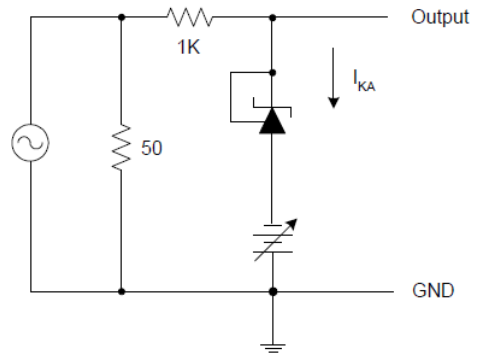
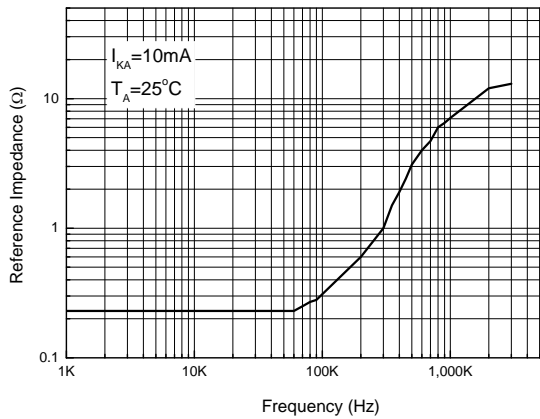

Stability Boundary Conditions vs. Load Capacitance

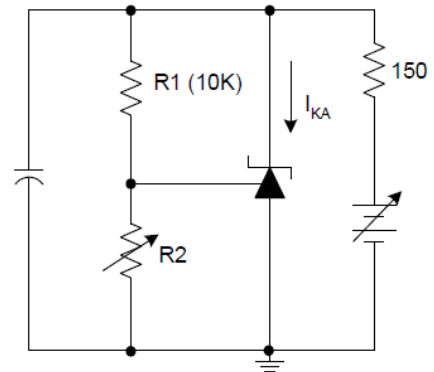
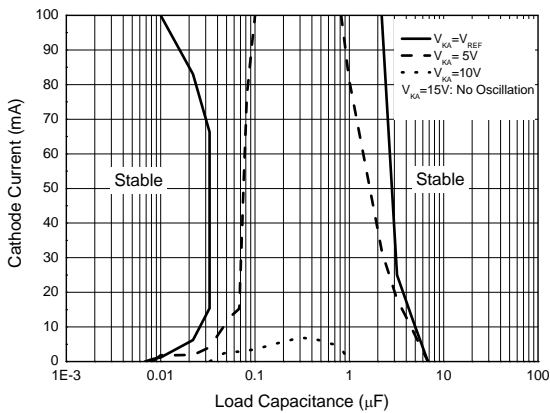

Performance Characteristics (Cont.)

Pulse Response of Input and Output Voltage

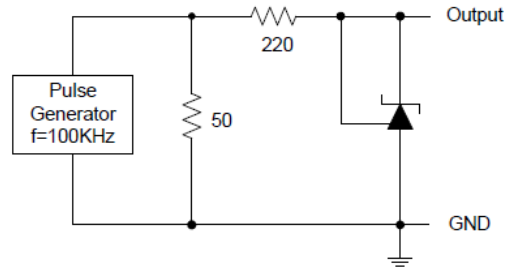
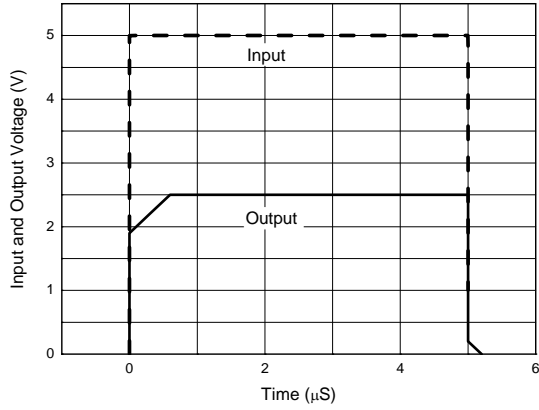

Ordering Information

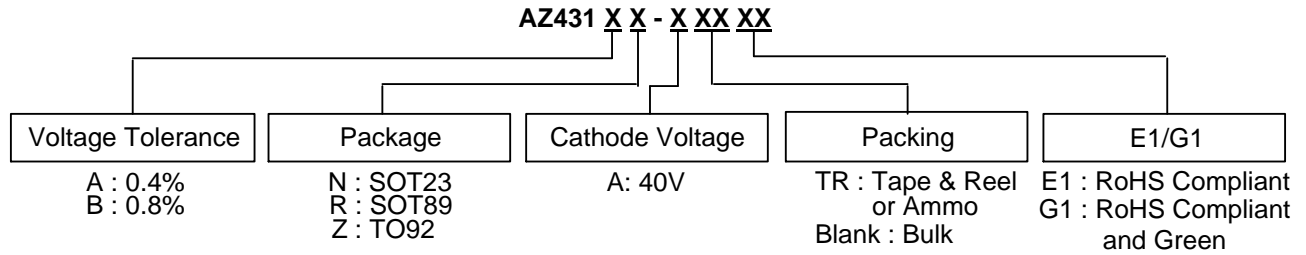

	Part Number	Voltage Tolerance	Package (Note 6)	RoHS Compliant Lead Free / Green	Marking ID	Packing	Quantity	Status (Note 5)	Alternative
 Lead-Free	AZ431AN-ATRE1	0.4%	SOT23	Lead Free	EA1	Tape & Reel	3000	NRND	AZ431AN-ATRG1
	AZ431BN-ATRE1	0.8%		Lead Free	EA2	Tape & Reel	3000	NRND	AZ431BN-ATRG1
	AZ431AN-ATRG1	0.4%		Green	GA1	Tape & Reel	3000	In Production	—
	AZ431BN-ATRG1	0.8%		Green	GA2	Tape & Reel	3000	In Production	—
 Lead-free Green	AZ431AK-ATRE1	0.4%	SOT25	Lead Free	E3A	Tape & Reel	3000	End of Life	None
	AZ431BK-ATRE1	0.8%		Lead Free	E3B	Tape & Reel	3000	End of Life	None
	AZ431AK-ATRG1	0.4%		Green	G3A	Tape & Reel	3000	End of Life	None
	AZ431BK-ATRG1	0.8%		Green	G3B	Tape & Reel	3000	End of Life	None
 Lead-Free	AZ431AZ-AE1	0.4%	TO92	Lead Free	AZ431AZ-AE1	Bulk	1000	In Production	—
	AZ431AZ-ATRE1	0.4%		Lead Free	AZ431AZ-AE1	Ammo	2000	In Production	—
	AZ431BZ-AE1	0.8%		Lead Free	AZ431BZ-AE1	Bulk	1000	In Production	—
	AZ431BZ-ATRE1	0.8%		Lead Free	AZ431BZ-AE1	Ammo	2000	In Production	—
	AZ431AZ-AG1	0.4%		Green	AZ431AZ-AG1	Bulk	1000	End of Life	AZ431AZ-ATRG1
	AZ431AZ-ATRG1	0.4%		Green	AZ431AZ-AG1	Ammo	2000	In Production	—
	AZ431BZ-AG1	0.8%		Green	AZ431BZ-AG1	Bulk	1000	End of Life	AZ431BZ-ATRG1
	AZ431BZ-ATRG1	0.8%		Green	AZ431BZ-AG1	Ammo	2000	In Production	—
 Lead-Free	AZ431AR-ATRE1	0.4%	SOT89	Lead Free	E43A	Tape & Reel	1000	NRND	None
	AZ431BR-ATRE1	0.8%		Lead Free	E43B	Tape & Reel	1000	NRND	None
	AZ431AR-ATRG1	0.4%		Green	G43A	Tape & Reel	1000	End of Life	None
	AZ431BR-ATRG1	0.8%		Green	G43B	Tape & Reel	1000	End of Life	None

- Notes:
5. All variants with SOT25 package are End of Life without alternatives.
NRND: Not Recommended for New Design.
 6. For packaging details, go to our website at: <https://www.diodes.com/design/support/packaging/diodes-packaging/>.

Marking Information

(1) TO92 (Bulk Packing)

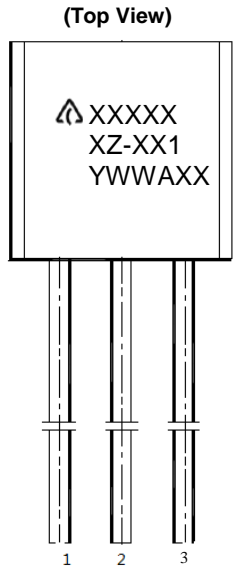

First and Second Lines: Logo and Marking ID
(See Ordering Information)
Third Line: Date Code
Y: Year
WW: Work Week of Molding
A: Assembly House Code
XX: 7th and 8th Digits of Batch Number

(2) TO92 (Ammo Packing)

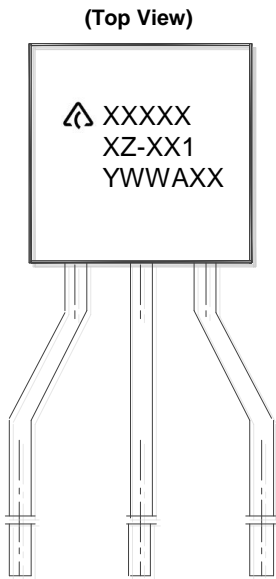

First and Second Lines: Logo and Marking ID
(See Ordering Information)
Third Line: Date Code
Y: Year
WW: Work Week of Molding
A: Assembly House Code
XX: 7th and 8th Digits of Batch Number

(3) SOT23

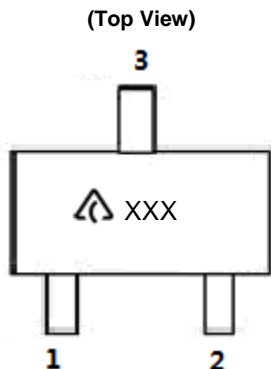



 : Logo
XXX: Marking ID
(See Ordering Information)

Marking Information (Cont.)

(4) SOT89

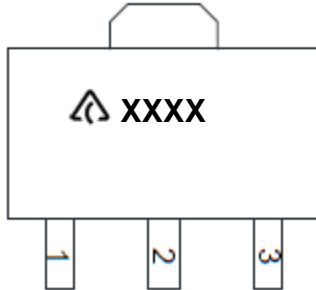
(Top View)



 : Logo
XXXX: Marking ID
(See Ordering Information)

Package Outline Dimensions (All dimensions in mm.)

(1) Package Type: TO92 (Bulk Packing)

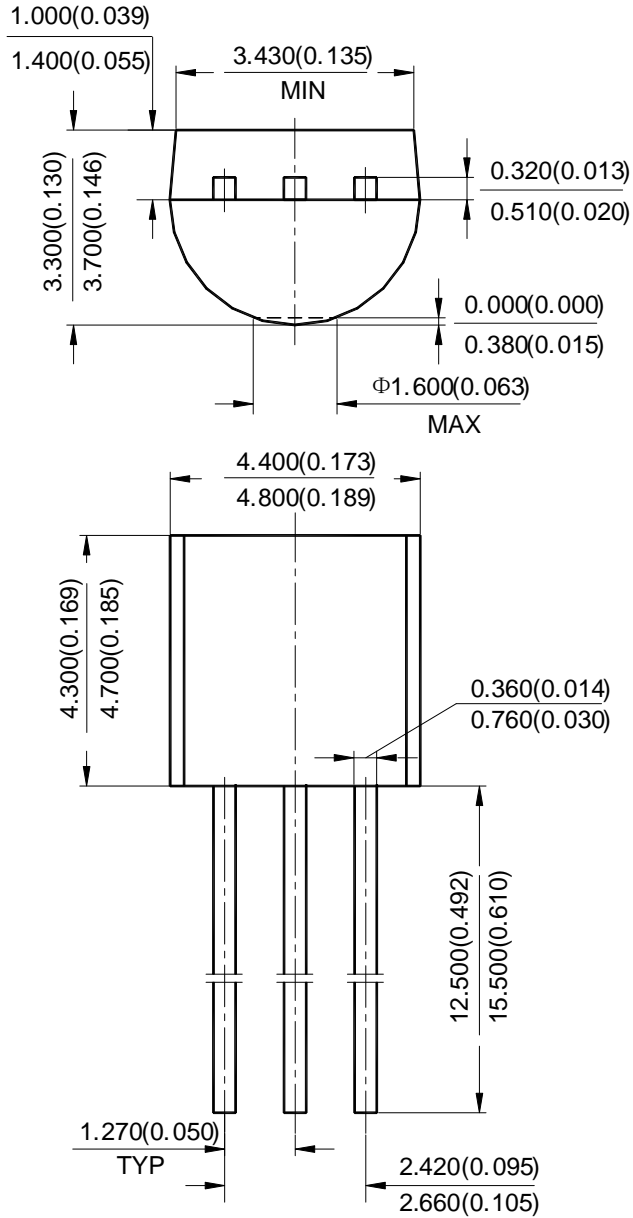

Package Outline Dimensions (Cont. All dimensions in mm.)

(2) Package Type: TO92 (Ammo Packing)

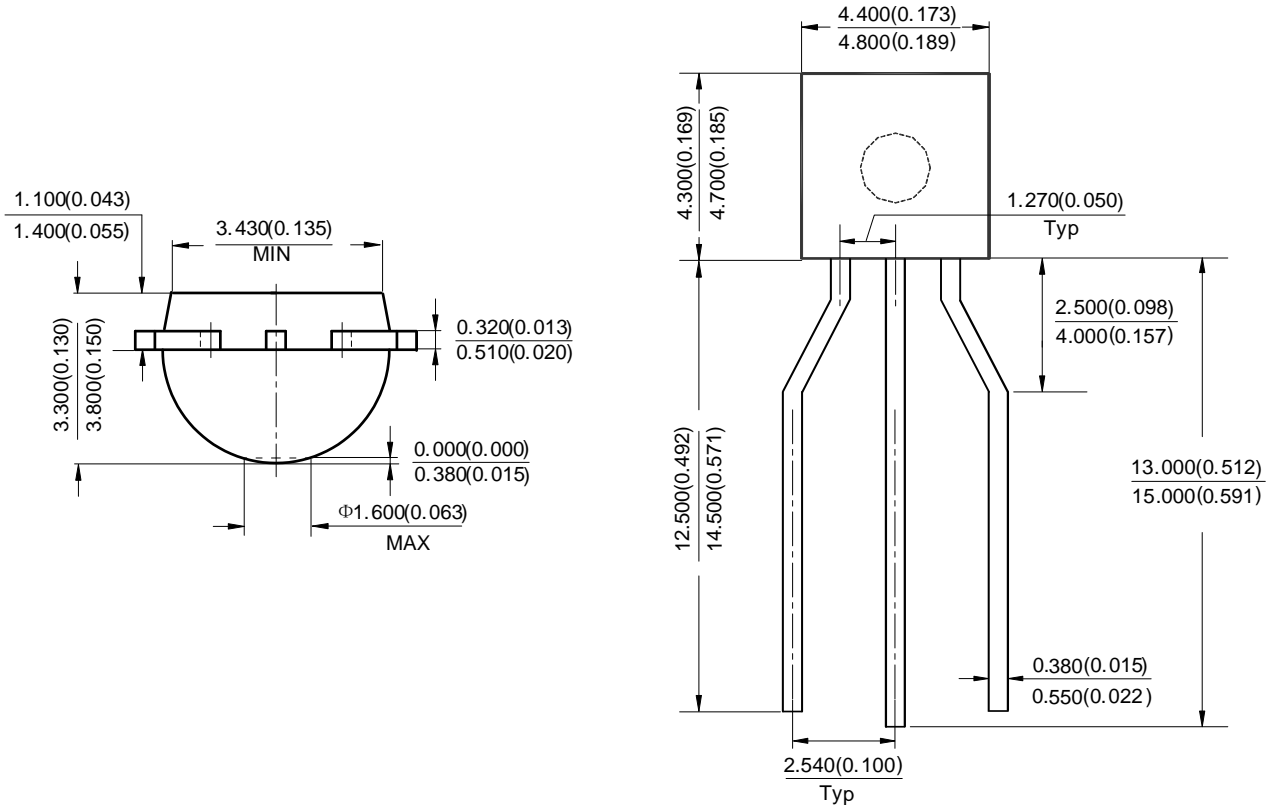

Package Outline Dimensions (Cont. All dimensions in mm.)

(3) Package Type: SOT23

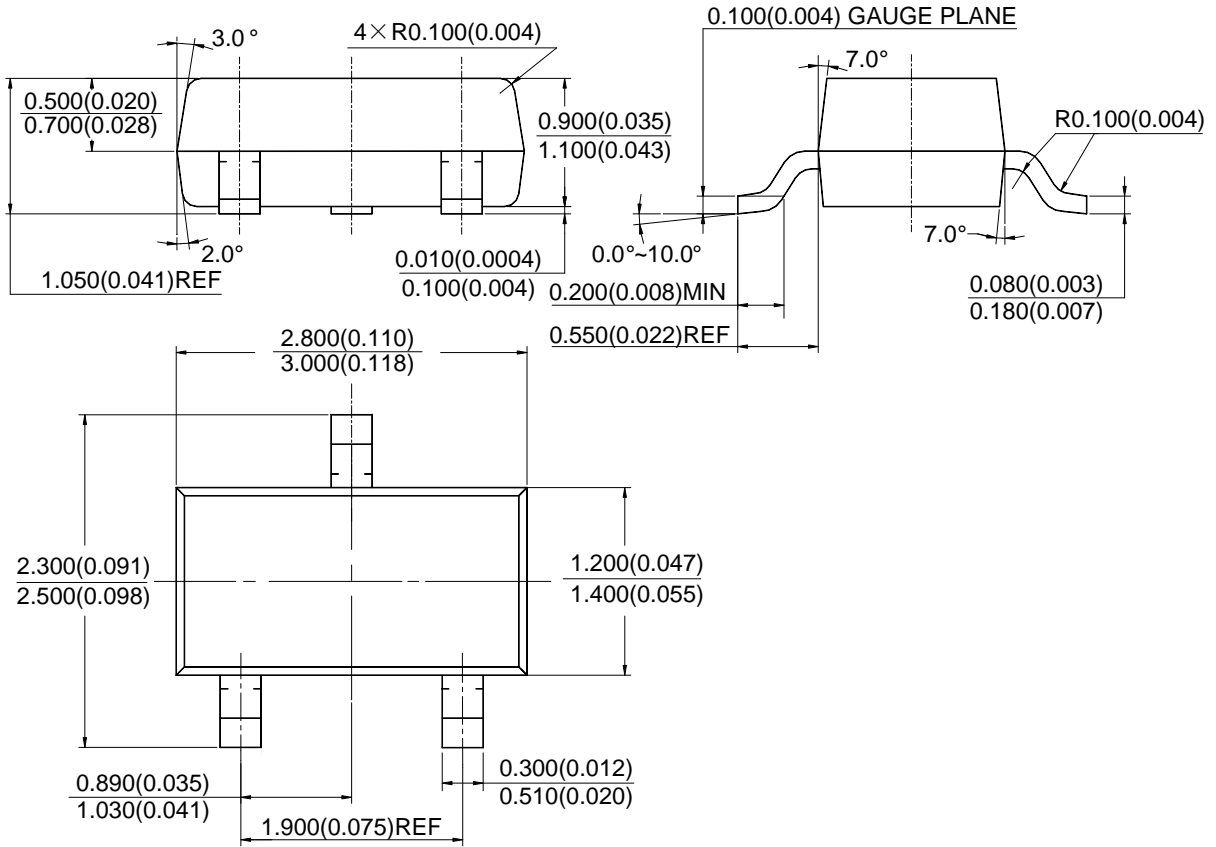

Package Outline Dimensions (Cont. All dimensions in mm.)

(4) Package Type: SOT89

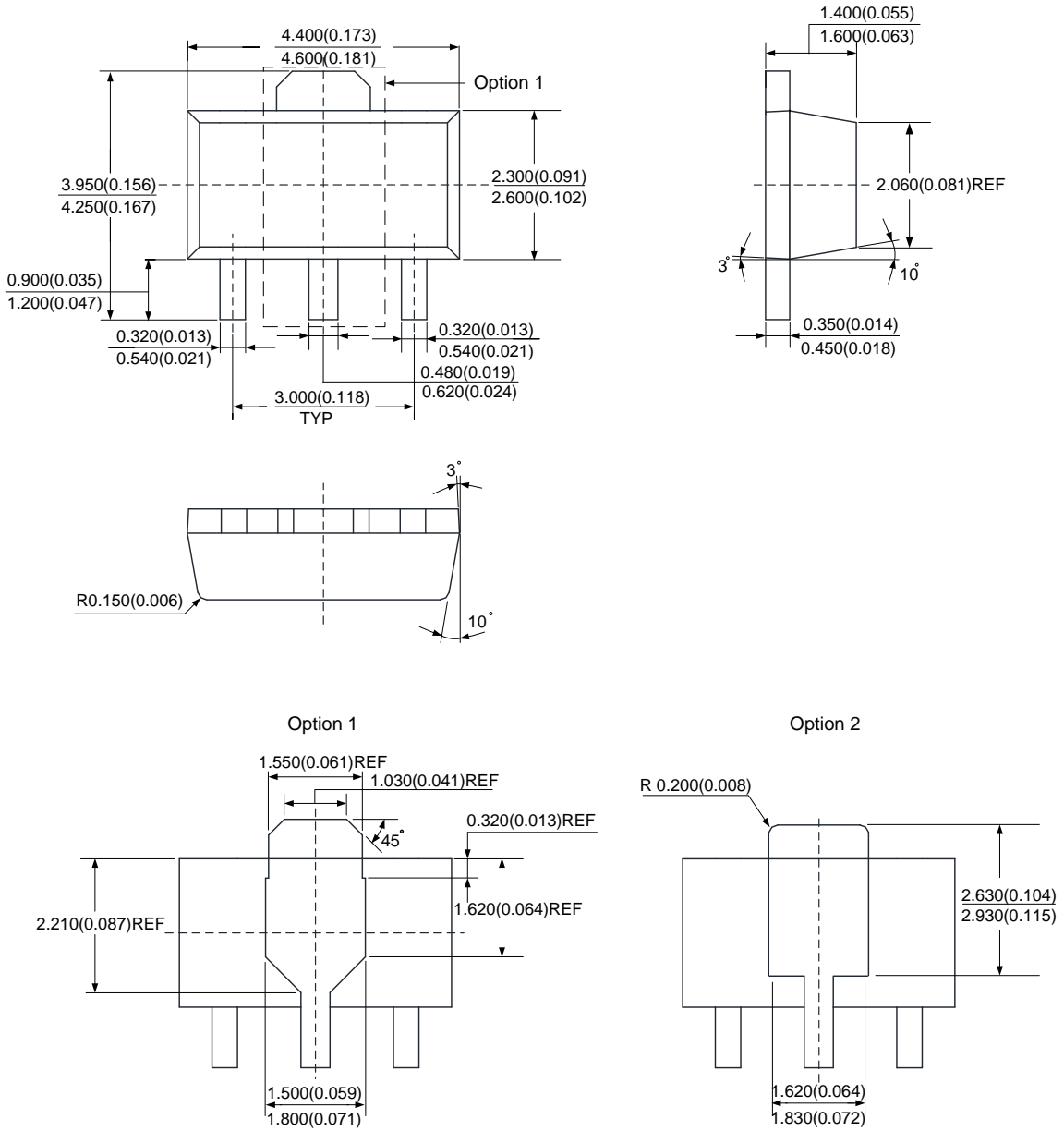

Suggested Pad Layout

(1) Package Type: SOT23

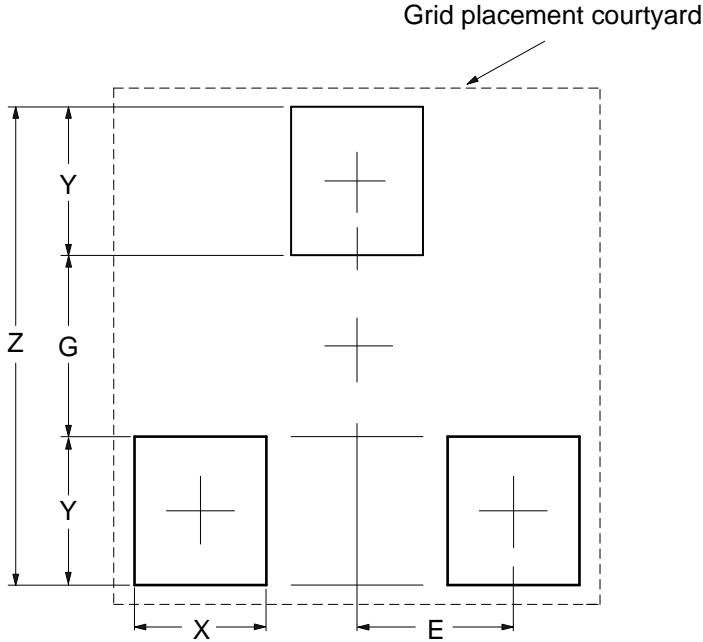

Dimensions	Z (mm)/(inch)	G (mm)/(inch)	X (mm)/(inch)	Y (mm)/(inch)	E (mm)/(inch)
Value	2.900/0.114	1.100/0.043	0.800/0.031	0.900/0.035	0.950/0.037

Suggested Pad Layout (Cont.)

(2) Package Type: SOT89

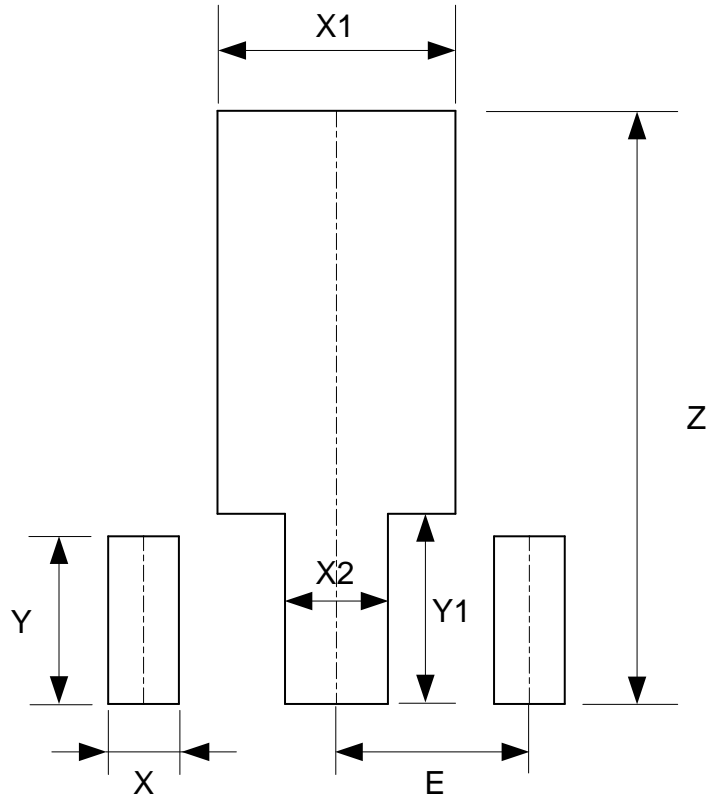

Dimensions	Z (mm)/(inch)	X (mm)/(inch)	X1 (mm)/(inch)	X2 (mm)/(inch)	Y (mm)/(inch)	Y1 (mm)/(inch)	E (mm)/(inch)
Value	4.600/0.181	0.550/0.022	1.850/0.073	0.800/0.031	1.300/0.051	1.475/0.058	1.500/0.059

IMPORTANT NOTICE

DIODES INCORPORATED MAKES NO WARRANTY OF ANY KIND, EXPRESS OR IMPLIED, WITH REGARDS TO THIS DOCUMENT, INCLUDING, BUT NOT LIMITED TO, THE IMPLIED WARRANTIES OF MERCHANTABILITY AND FITNESS FOR A PARTICULAR PURPOSE (AND THEIR EQUIVALENTS UNDER THE LAWS OF ANY JURISDICTION).

Diodes Incorporated and its subsidiaries reserve the right to make modifications, enhancements, improvements, corrections or other changes without further notice to this document and any product described herein. Diodes Incorporated does not assume any liability arising out of the application or use of this document or any product described herein; neither does Diodes Incorporated convey any license under its patent or trademark rights, nor the rights of others. Any Customer or user of this document or products described herein in such applications shall assume all risks of such use and will agree to hold Diodes Incorporated and all the companies whose products are represented on Diodes Incorporated website, harmless against all damages.

Diodes Incorporated does not warrant or accept any liability whatsoever in respect of any products purchased through unauthorized sales channel. Should Customers purchase or use Diodes Incorporated products for any unintended or unauthorized application, Customers shall indemnify and hold Diodes Incorporated and its representatives harmless against all claims, damages, expenses, and attorney fees arising out of, directly or indirectly, any claim of personal injury or death associated with such unintended or unauthorized application.

Products described herein may be covered by one or more United States, international or foreign patents pending. Product names and markings noted herein may also be covered by one or more United States, international or foreign trademarks.

This document is written in English but may be translated into multiple languages for reference. Only the English version of this document is the final and determinative format released by Diodes Incorporated.

LIFE SUPPORT

Diodes Incorporated products are specifically not authorized for use as critical components in life support devices or systems without the express written approval of the Chief Executive Officer of Diodes Incorporated. As used herein:

A. Life support devices or systems are devices or systems which:

1. are intended to implant into the body, or
2. support or sustain life and whose failure to perform when properly used in accordance with instructions for use provided in the labeling can be reasonably expected to result in significant injury to the user.

B. A critical component is any component in a life support device or system whose failure to perform can be reasonably expected to cause the failure of the life support device or to affect its safety or effectiveness.

Customers represent that they have all necessary expertise in the safety and regulatory ramifications of their life support devices or systems, and acknowledge and agree that they are solely responsible for all legal, regulatory and safety-related requirements concerning their products and any use of Diodes Incorporated products in such safety-critical, life support devices or systems, notwithstanding any devices- or systems-related information or support that may be provided by Diodes Incorporated. Further, Customers must fully indemnify Diodes Incorporated and its representatives against any damages arising out of the use of Diodes Incorporated products in such safety-critical, life support devices or systems.

Copyright © 2018, Diodes Incorporated

www.diodes.com

Looking for pricing, stock, or lifecycle information?

Click below to explore more details on WIN SOURCE:

-  [View AZ431AZ-AE1 on WIN SOURCE](#)
-  [Diodes Incorporated Information](#)

Optimize Your Supply Chain with WIN SOURCE Solutions

-  Global Sourcing Solution
-  Obsolete Management
-  Cost Control Management
-  Shortage Management
-  Alternative Solution
-  Excess Inventory Management