



**THE DATASHEET OF
AZ431LANTR-G1**



Description

The AZ431L series ICs are low voltage three-terminal adjustable regulators with guaranteed thermal stability over a full operation range. These ICs feature sharp turn-on characteristics, low temperature coefficient and low output impedance, which make them ideal substitutes for Zener diodes in applications such as switching power supply, charger, motherboard and other adjustable regulators.

The output voltage can be set to any value between 1.24V and 18V with two external resistors.

The AZ431L precision reference is offered in two voltage tolerance: 0.5% and 1.0%.

These ICs are available in 4 packages: TO92 (bulk or ammo packing), SOT23, SOT25 and SOT89.

Features

- Wide Programmable Precise Output Voltage from 1.24V to 18V
- High Stability under Capacitive Load
- Low Temperature Deviation: 3mV Typical
- Low Equivalent Full-range Temperature Coefficient: 20PPM/°C Typical
- Low Dynamic Output Resistance: 0.05Ω Typical
- High Sink Current Capacity from 0.1mA to 100mA
- Low Output Noise
- Wide Operating Range of -40 to +125°C
- Lead-Free Packages: TO92, SOT23, SOT25, SOT89
 - **Totally Lead-Free; RoHS Compliant (Notes 1 & 2)**
- Lead-Free Packages, Available in "Green" Molding Compound: TO92, SOT23, SOT25, SOT89
 - **Totally Lead-Free & Fully RoHS Compliant (Notes 1 & 2)**
 - **Halogen and Antimony Free. "Green" Device (Note 3)**

Applications

- Graphic Card
- PC Motherboard
- Voltage Adapter
- Switching Power Supply
- Charger

- Notes:
1. No purposely added lead. Fully EU Directive 2002/95/EC (RoHS), 2011/65/EU (RoHS 2) & 2015/863/EU (RoHS 3) compliant.
 2. See <https://www.diodes.com/quality/lead-free/> for more information about Diodes Incorporated's definitions of Halogen- and Antimony-free, "Green" and Lead-free.
 3. Halogen- and Antimony-free "Green" products are defined as those which contain <900ppm bromine, <900ppm chlorine (<1500ppm total Br + Cl) and <1000ppm antimony compounds.

Pin Assignments

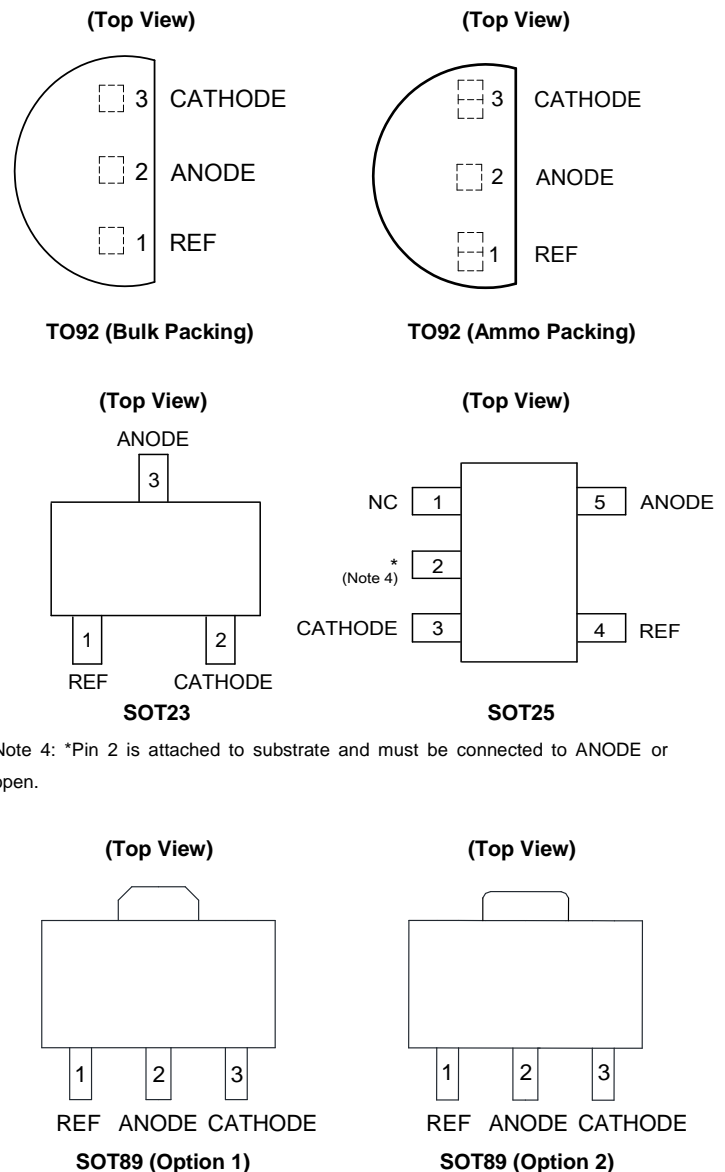

Note 4: *Pin 2 is attached to substrate and must be connected to ANODE or open.

Typical Applications Circuit

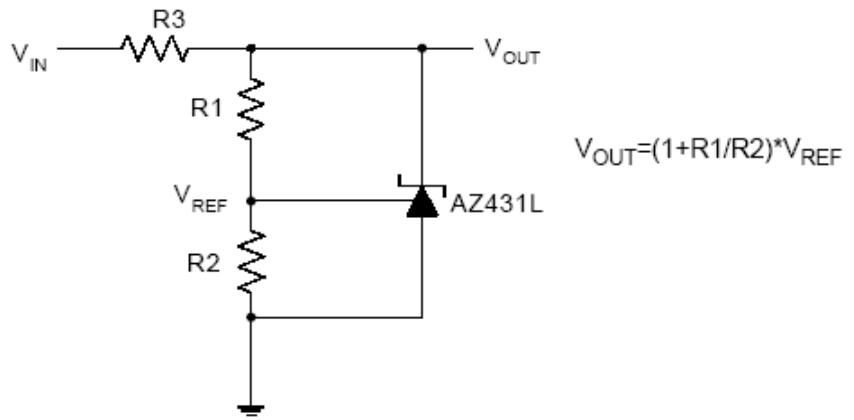

$$V_{OUT} = (1 + R1/R2) * V_{REF}$$

Shunt Regulator

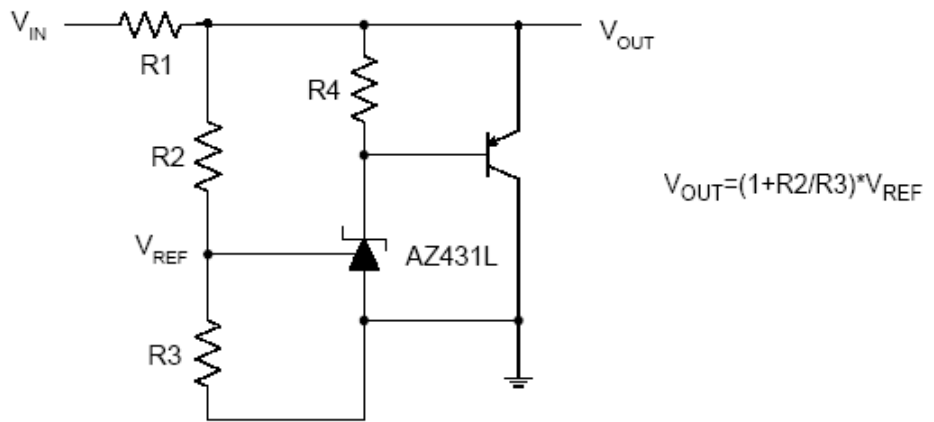

$$V_{OUT} = (1 + R2/R3) * V_{REF}$$

High Current Shunt Regulator

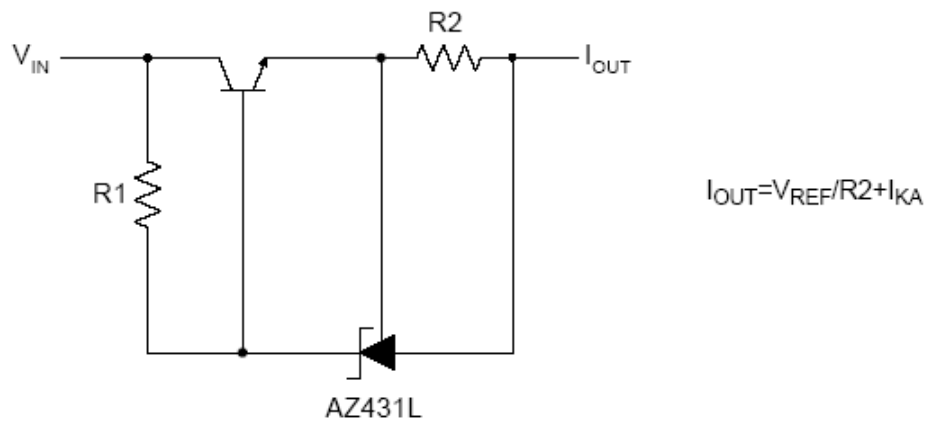

$$I_{OUT} = V_{REF}/R2 + I_{KA}$$

Current Source or Current Limit

Typical Applications Circuit (Cont.)

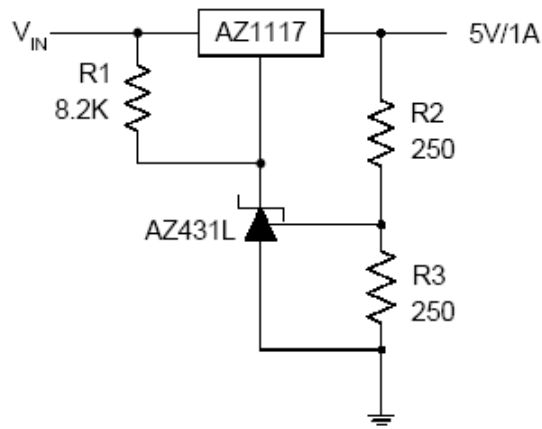

Precision 5V 1A Regulator

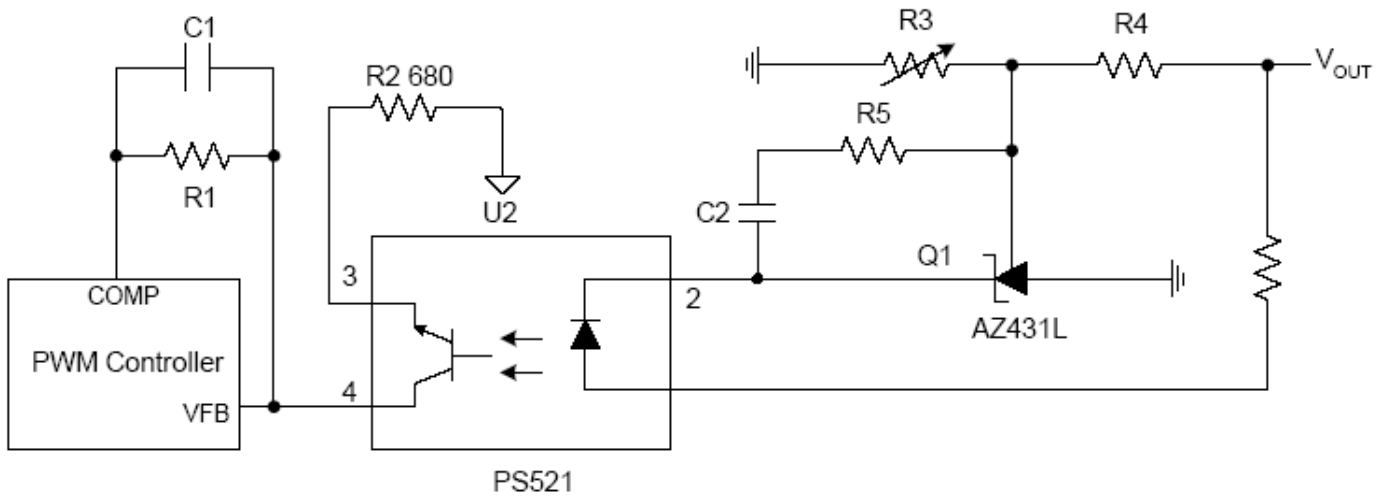

PWM Converter with Reference

Functional Block Diagram

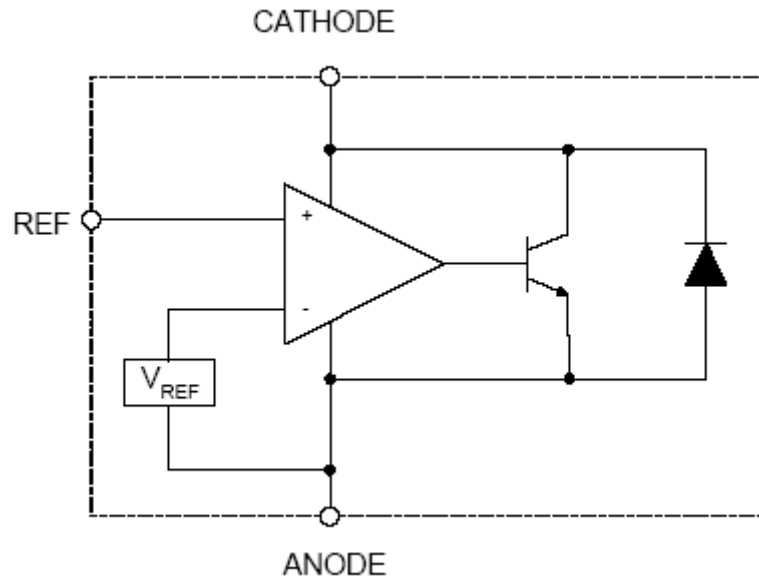

Absolute Maximum Ratings (Note 5)

Symbol	Parameter	Rating		Unit
V_{KA}	Cathode Voltage	20		V
I_{KA}	Cathode Current Range (Continuous)	-100 to 100		mA
I_{REF}	Reference Input Current Range	10		mA
P_D	Power Dissipation	Z, R Package	770	mW
		N, K Package	370	
T_J	Junction Temperature	+150		°C
T_{STG}	Storage Temperature Range	-65 to +150		°C

Note 5: Stresses greater than those listed under “Absolute Maximum Ratings” may cause permanent damage to the device. These are stress ratings only, and functional operation of the device at these or any other conditions beyond those indicated under “Recommended Operating Conditions” is not implied. Exposure to “Absolute Maximum Ratings” for extended periods may affect device reliability.

Recommended Operating Conditions

Symbol	Parameter	Min	Max	Unit
V_{KA}	Cathode Voltage	V_{REF}	18	V
I_{KA}	Cathode Current	0.1	100	mA
—	Operating Ambient Temperature Range	-40	+125	°C

Electrical Characteristics (Operating Conditions: $T_A = +25\text{ }^\circ\text{C}$, unless otherwise noted.)

Symbol	Parameter		Test Circuit	Conditions	Min	Typ	Max	Unit	
V_{REF}	Reference Voltage	0.5%	4	$V_{KA} = V_{REF}, I_{KA} = 10\text{mA}$	1.234	1.240	1.246	V	
		1.0%			1.228	1.240	1.252		
ΔV_{REF}	Deviation of Reference Voltage Over Full Temperature Range		4	$V_{KA} = V_{REF}, I_{KA} = 10\text{mA}$	0 to $+70\text{ }^\circ\text{C}$	—	2	10	mV
					-40 to $+85\text{ }^\circ\text{C}$	—	3	10	
					-40 to $+125\text{ }^\circ\text{C}$	—	4	15	
$\frac{\Delta V_{REF}}{\Delta V_{KA}}$	Ratio of Change in V_{REF} to the Change in Cathode Voltage		5	$I_{KA} = 10\text{mA}, \Delta V_{KA}: V_{REF} \text{ to } 16\text{V}$	—	-0.5	-1.5	mV/V	
I_{REF}	Reference Input Current		5	$I_{KA} = 10\text{mA}, R1 = 10\text{k}\Omega, R2 = \infty$	—	0.15	0.4	μA	
ΔI_{REF}	Deviation of Reference Current Over Full Temperature Range		5	$I_{KA} = 10\text{mA}, R1 = 10\text{k}\Omega, R2 = \infty, T_A = -40 \text{ to } +125\text{ }^\circ\text{C}$	—	0.1	0.4	μA	
I_{KA} (Min)	Minimum Cathode Current for Regulation		4	$V_{KA} = V_{REF}$	—	55	80	μA	
I_{KA} (Off)	Off-state Cathode Current		6	$V_{REF} = 0, V_{KA} = 18\text{V}$	—	0.04	0.10	μA	
				$V_{KA} = 6, V_{REF} = 0$	—	0.01	0.05		
Z_{KA}	Dynamic Impedance		4	$V_{KA} = V_{REF}, I_{KA} = 1 \text{ to } 100\text{mA}, f \leq 1.0\text{kHz}$	—	0.05	0.15	Ω	
θ_{JC}	Thermal Resistance		—	SOT23	—	84.84	—	$^\circ\text{C/W}$	
				SOT25	—	84.84	—		
				TO92	—	140.80	—		
				SOT89	—	29.80	—		

Electrical Characteristics (Cont.)

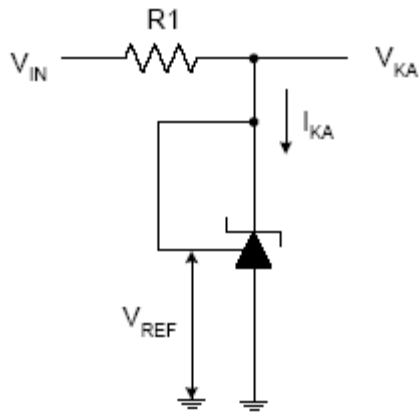

Test Circuit 4 for $V_{KA} = V_{REF}$

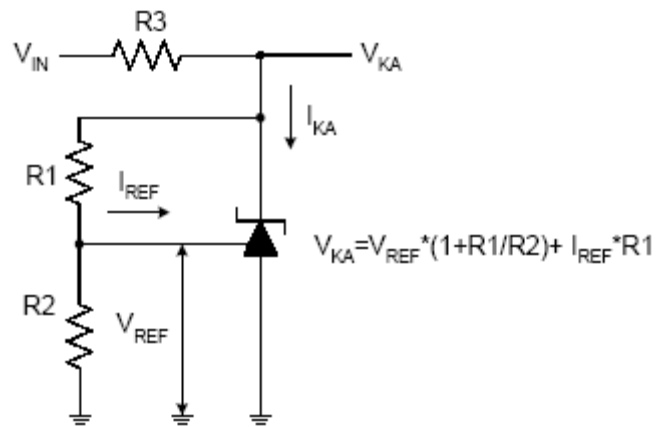

Test Circuit 5 for $V_{KA} > V_{REF}$

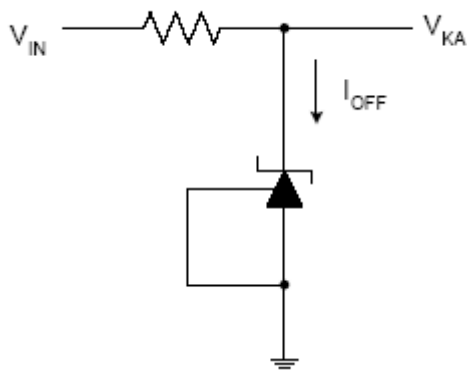

Test Circuit 6 for I_{OFF}

Performance Characteristics

Reference Voltage vs. Ambient Temperature

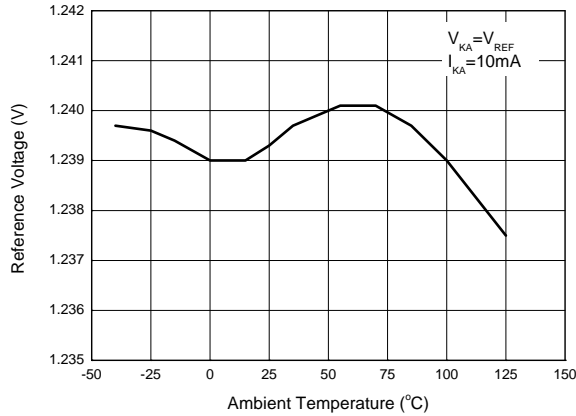

Reference Current vs. Ambient Temperature

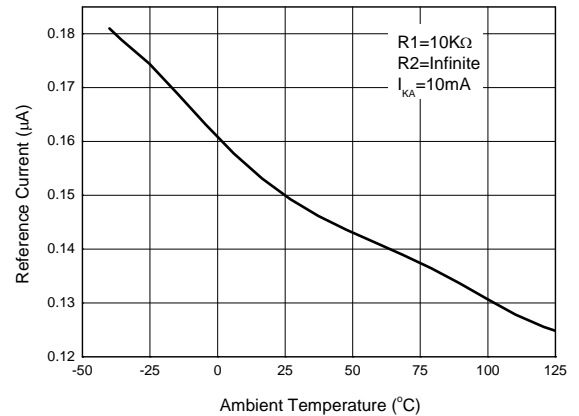

Cathode Current vs. Cathode Voltage

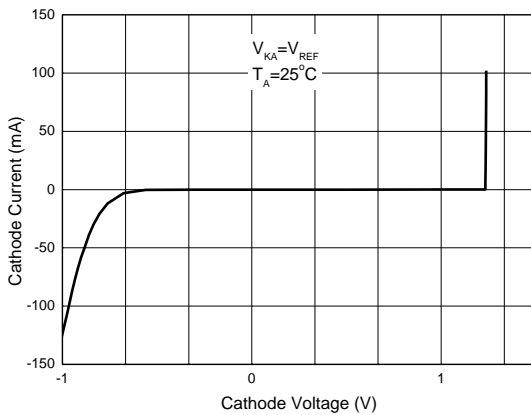

Cathode Current vs. Cathode Voltage

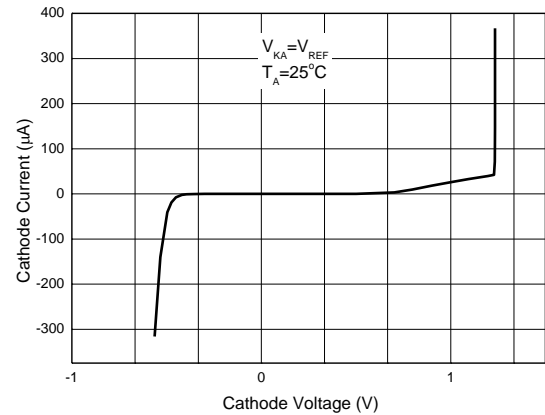

Small Signal Voltage Gain vs. Frequency

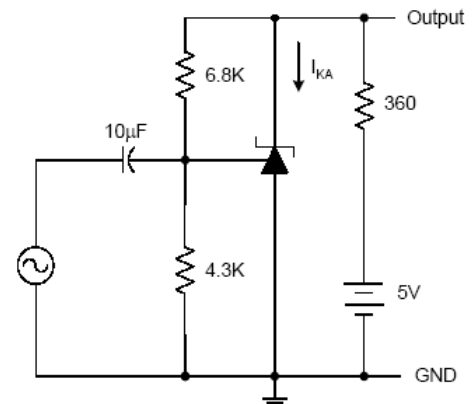
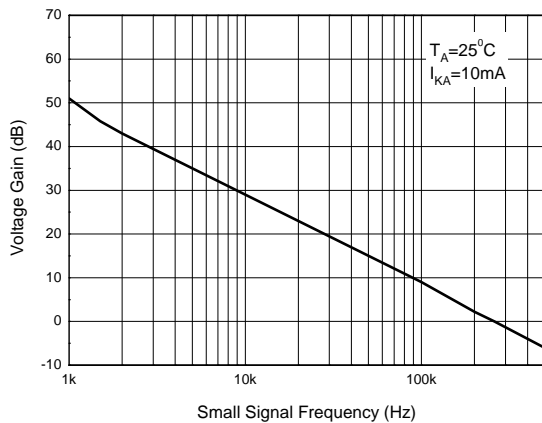

Performance Characteristics (Cont.)

Dynamic Impedance vs. Frequency

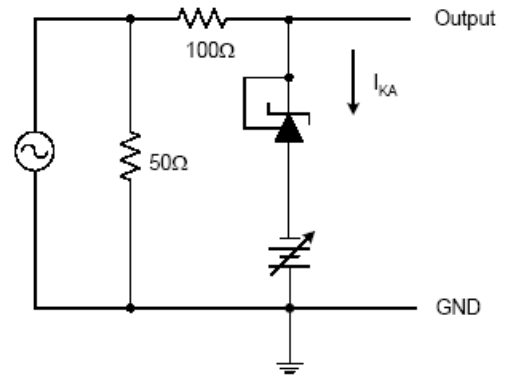
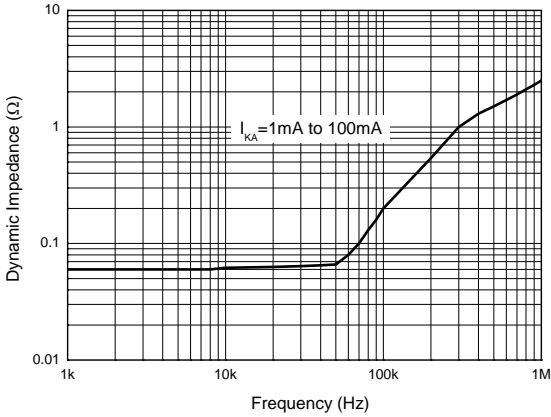

Pulse Response of Input and Output Voltage

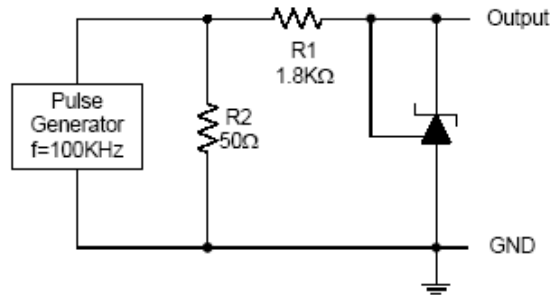
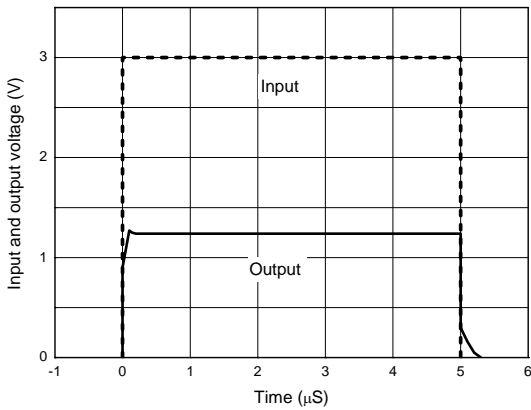



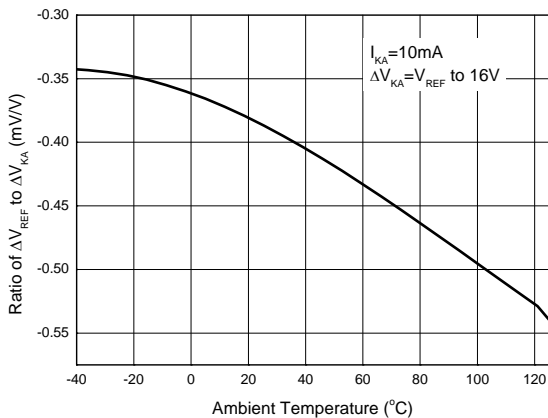

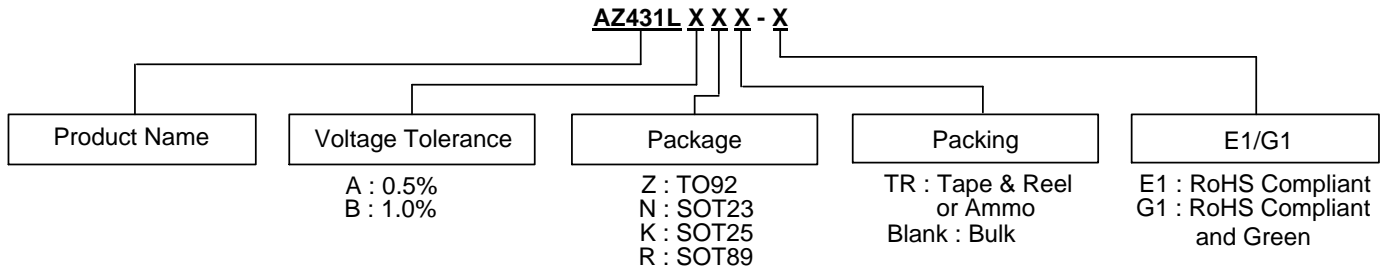

Ratio of Delta Reference Voltage to the Ratio of Cathode Voltage vs. Ambient Temperature



Ordering Information



Part Number	Voltage Tolerance	Package (Note 7)	RoHS Compliant Lead Free / Green	Marking ID	Packing	Quantity	Status (Note 6)	Alternative
AZ431LAZ-E1	0.5%	TO92	Lead Free	AZ431LAZ-E1	Bulk	1000	End of Life	AZ431LAZTR-E1
 AZ431LAZTR-E1	0.5%	TO92	Lead Free	AZ431LAZ-E1	Ammo	2000	In Production	—
AZ431LBZ-E1	1.0%	TO92	Lead Free	AZ431LBZ-E1	Bulk	1000	End of Life	AZ431LBZTR-E1
AZ431LBZTR-E1	1.0%	TO92	Lead Free	AZ431LBZ-E1	Ammo	2000	In Production	—
AZ431LAZ-G1	0.5%	TO92	Green	AZ431LAZ-G1	Bulk	1000	End of Life	AZ431LAZTR-E1
 AZ431LAZTR-G1	0.5%	TO92	Green	AZ431LAZ-G1	Ammo	2000	In Production	—
AZ431LBZ-G1	1.0%	TO92	Green	AZ431LBZ-G1	Bulk	1000	In Production	—
AZ431LBZTR-G1	1.0%	TO92	Green	AZ431LBZ-G1	Ammo	2000	In Production	—
 AZ431LANTR-E1	0.5%	SOT23	Lead Free	EA6	Tape & Reel	3000	NRND	None
AZ431LBNTR-E1	1.0%	SOT23	Lead Free	EA7	Tape & Reel	3000	NRND	None
 AZ431LANTR-G1	0.5%	SOT23	Green	GA6	Tape & Reel	3000	In Production	—
AZ431LBNTR-G1	1.0%	SOT23	Green	GA7	Tape & Reel	3000	In Production	—
 AZ431LAKTR-E1	0.5%	SOT25	Lead Free	E5A	Tape & Reel	3000	NRND	None
AZ431LBKTR-E1	1.0%	SOT25	Lead Free	E6A	Tape & Reel	3000	NRND	None
 AZ431LAKTR-G1	0.5%	SOT25	Green	G5A	Tape & Reel	3000	In Production	—
AZ431LBKTR-G1	1.0%	SOT25	Green	G6A	Tape & Reel	3000	In Production	—
 AZ431LARTR-E1	0.5%	SOT89	Lead Free	E41A	Tape & Reel	1000	End of Life	AZ431LARTR-G1
AZ431LBRTR-E1	1.0%	SOT89	Lead Free	E41B	Tape & Reel	1000	NRND	None
 AZ431LARTR-G1	0.5%	SOT89	Green	G41A	Tape & Reel	1000	In Production	—
AZ431LBRTR-G1	1.0%	SOT89	Green	G41B	Tape & Reel	1000	In Production	—

Notes: 6. NRND: Not Recommended For New Design.

7. For packaging details, go to our website at: <https://www.diodes.com/design/support/packaging/diodes-packaging/>.

Marking Information

(1) TO92 (Bulk Packing)

(Front View)

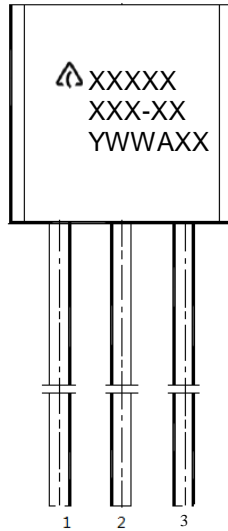

First and Second Lines: Logo and Marking ID
(See Ordering Information)
Third Line: Date Code
Y: Year
WW: Work Week of Molding
A: Assembly House Code
XX: Internal Code

(2) TO92 (Ammo Packing)

(Front View)

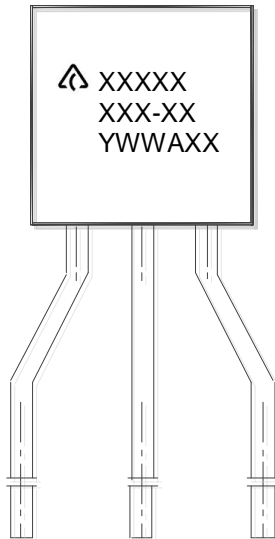

First and Second Lines: Logo and Marking ID
(See Ordering Information)
Third Line: Date Code
Y: Year
WW: Work Week of Molding
A: Assembly House Code
XX: Internal Code

(3) SOT23

(Top View)

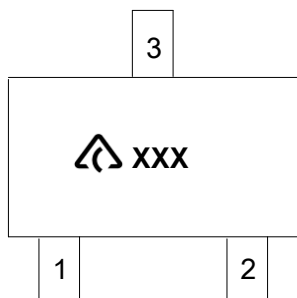

 : Logo
XXX: Marking ID (See Ordering Information)

Marking Information (Cont.)

(4) SOT89

(Top View)

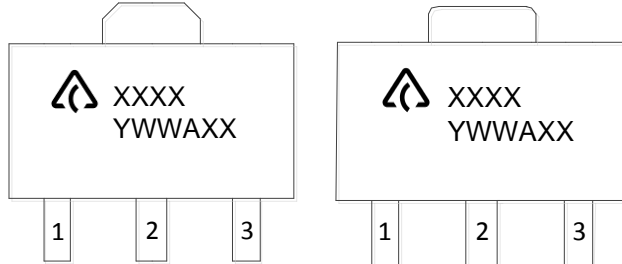

First Line: Logo and Marking ID (See Ordering Information)
Second Line: Date Code
Y: Year
WW: Work Week of Molding
A: Assembly House Code
XX: Internal Code

(5) SOT25

(Top View)

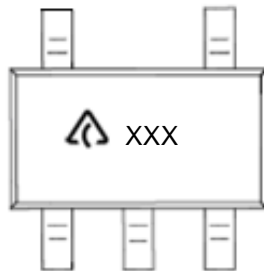

 : Logo
XXX: Marking ID (See Ordering Information)

Package Outline Dimensions (All dimensions in mm (inch).)

(1) Package Type: TO92 (Bulk Packing)

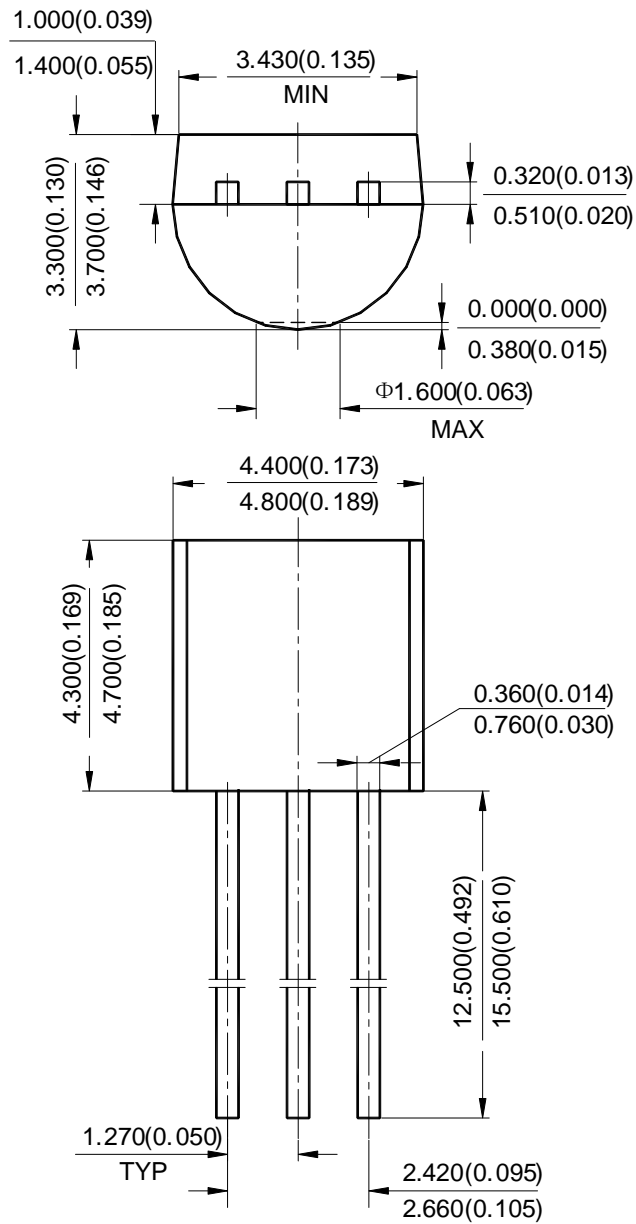

Package Outline Dimensions (Cont. All dimensions in mm(inch).)

(2) Package Type: TO92 (Ammo Packing)

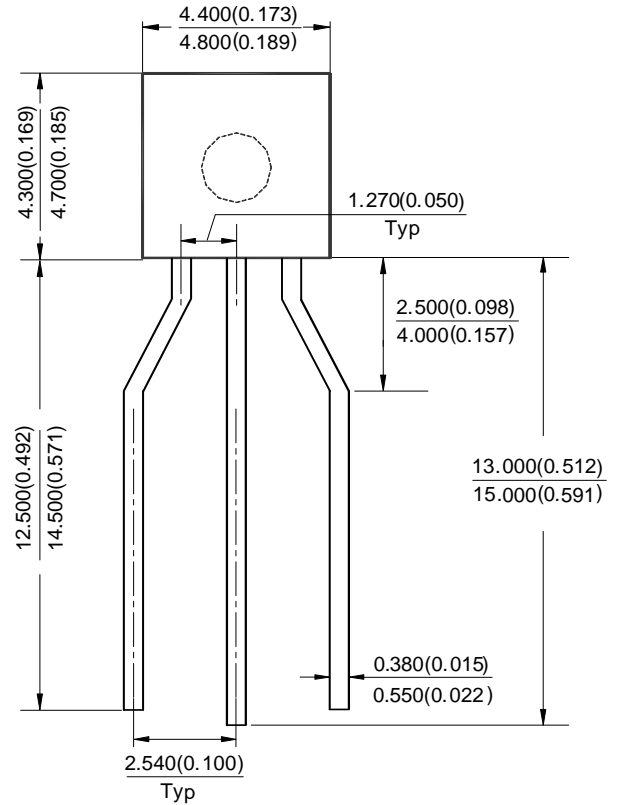
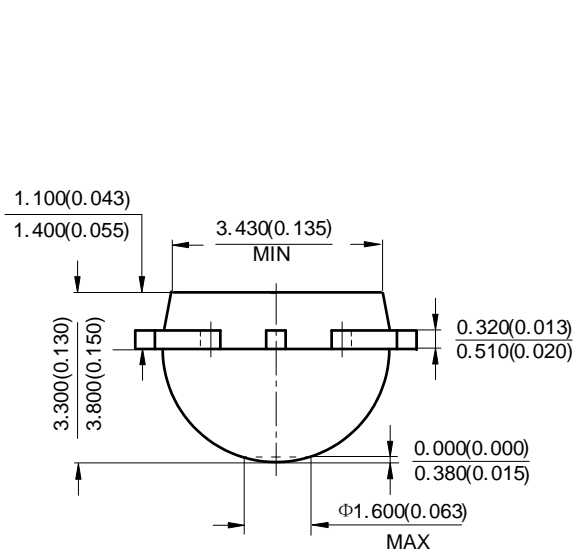

Package Outline Dimensions (Cont. All dimensions in mm(inch).)

(3) Package Type: SOT23

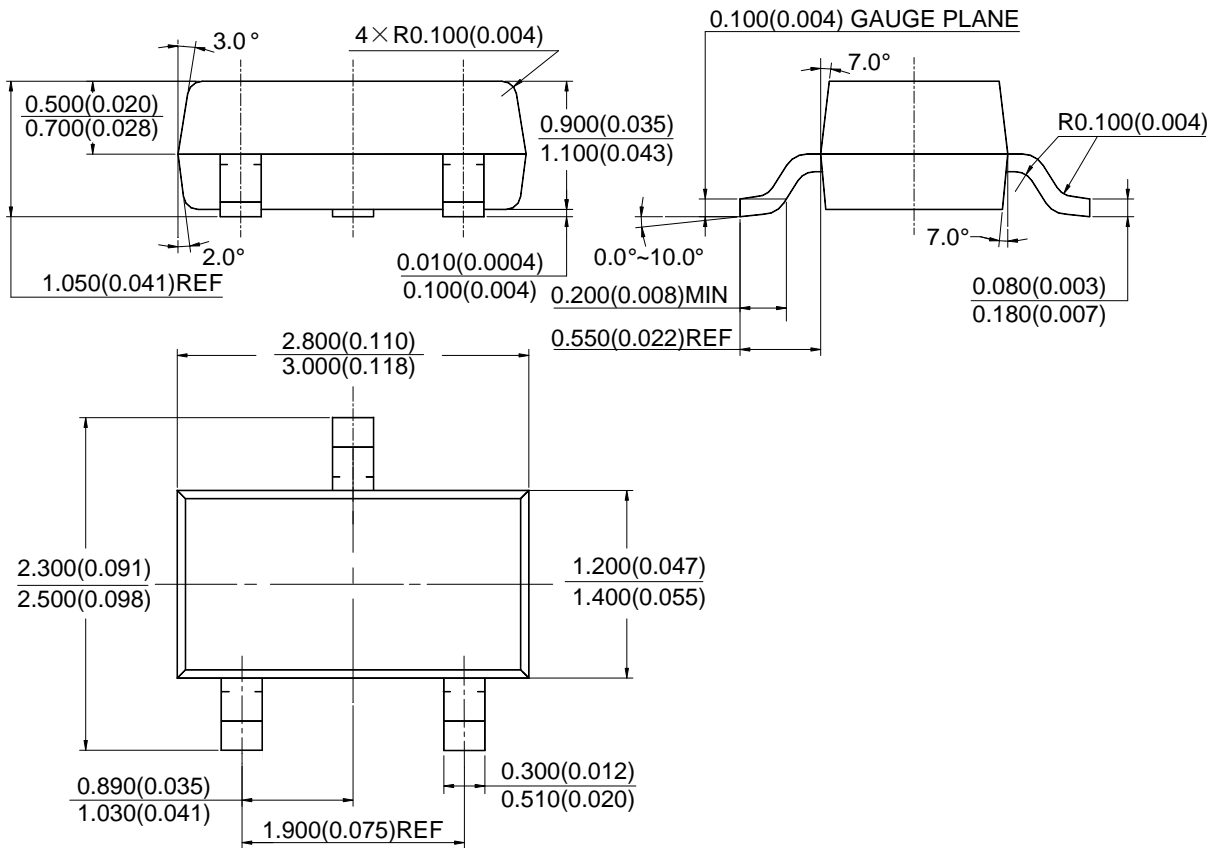

Package Outline Dimensions (Cont. All dimensions in mm(inch).)

(4) Package Type: SOT25

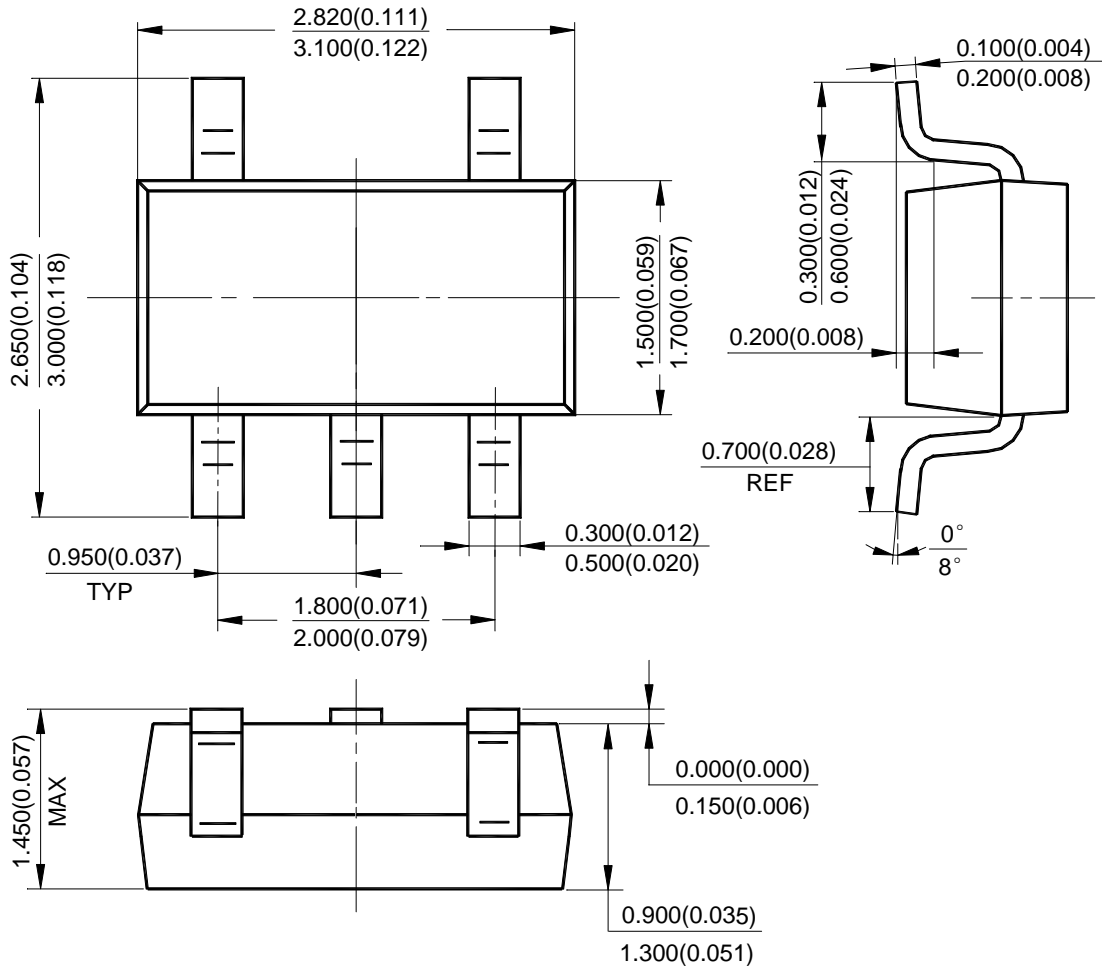

Package Outline Dimensions (Cont. All dimensions in mm(inch).)

(5) Package Type: SOT89

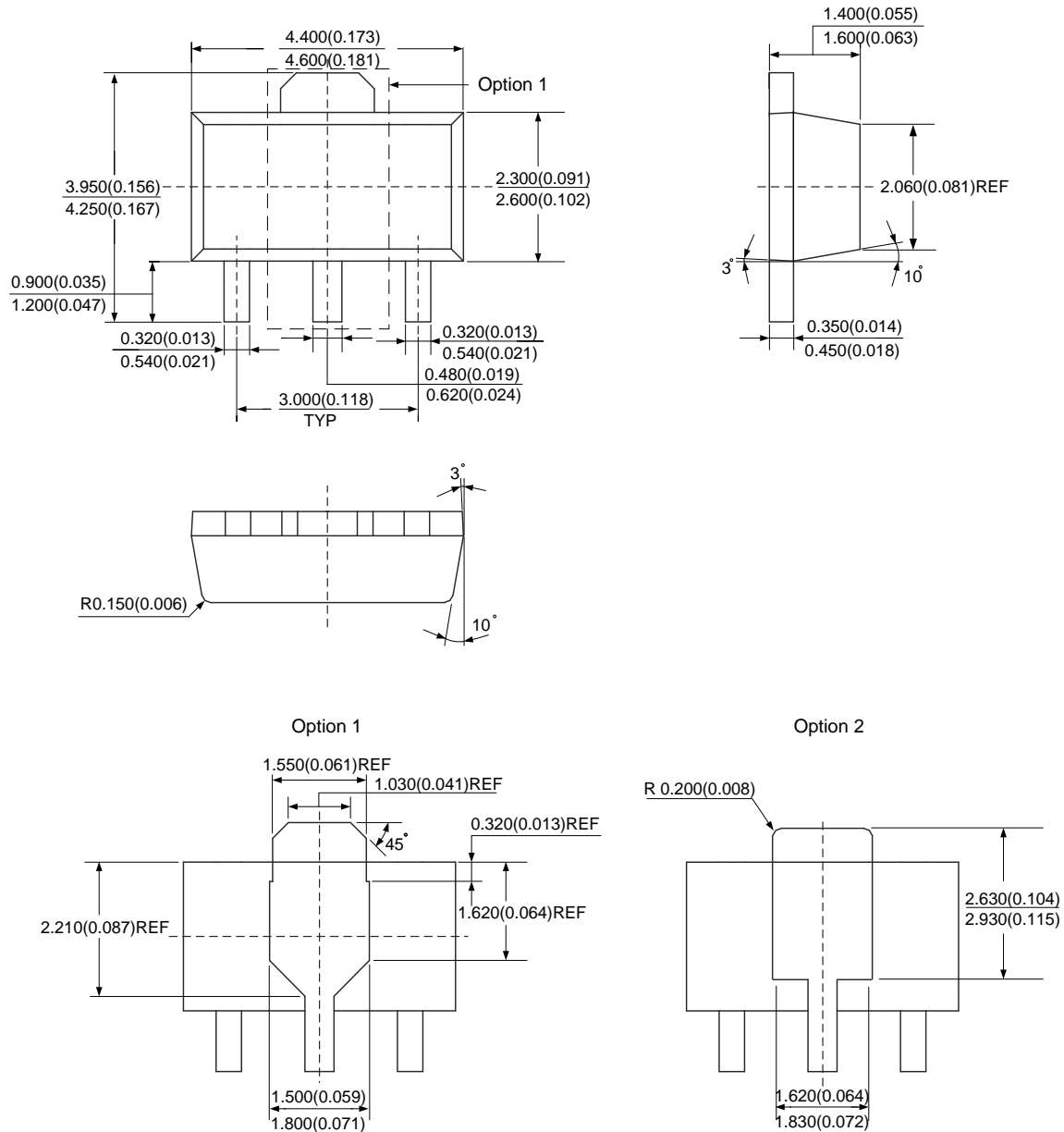

Suggested Pad Layout

(1) Package Type: SOT23

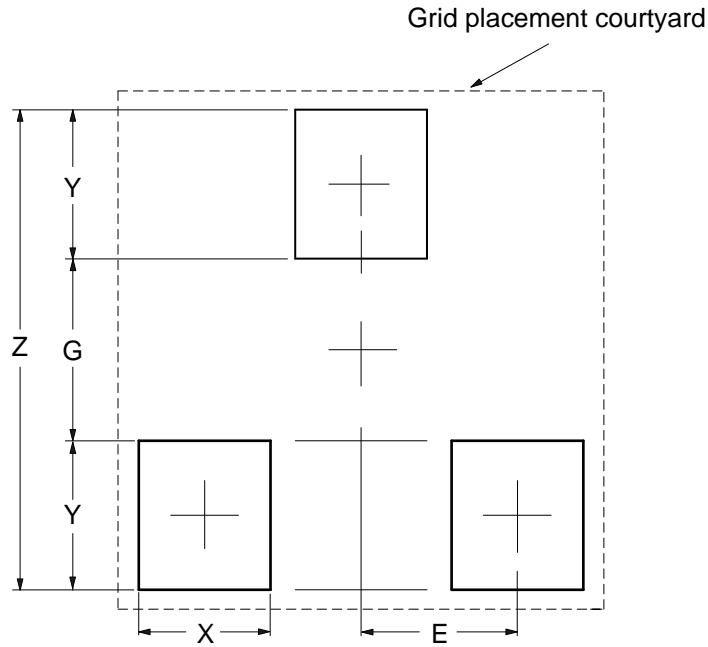

Dimensions	Z (mm)/(inch)	G (mm)/(inch)	X (mm)/(inch)	Y (mm)/(inch)	E (mm)/(inch)
Value	2.900/0.114	1.100/0.043	0.800/0.031	0.900/0.035	0.950/0.037

Suggested Pad Layout (Cont.)

(2) Package Type: SOT25

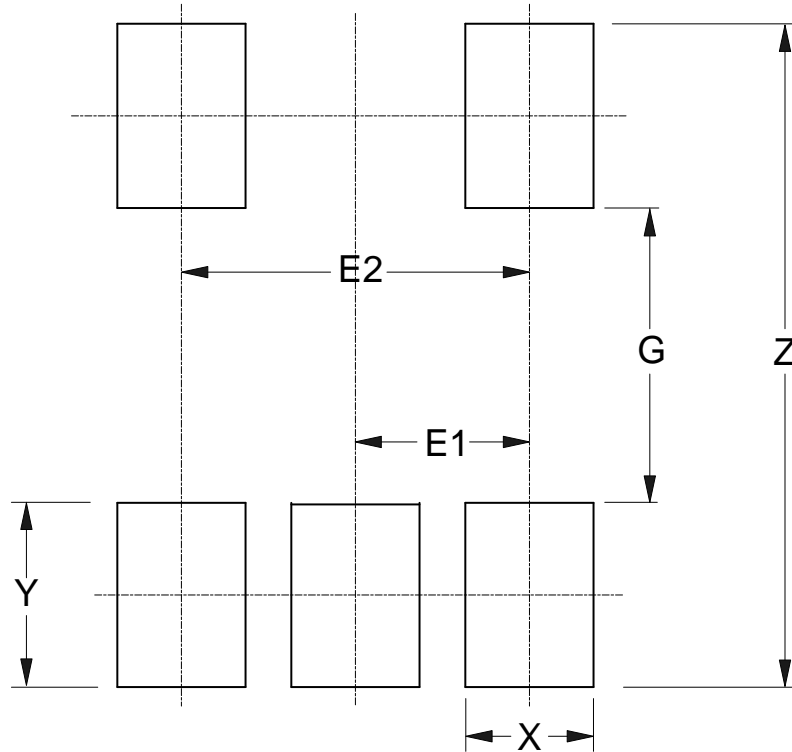

Dimensions	Z (mm)/(inch)	G (mm)/(inch)	X (mm)/(inch)	Y (mm)/(inch)	E1 (mm)/(inch)	E2 (mm)/(inch)
Value	3.600/0.142	1.600/0.063	0.700/0.028	1.000/0.039	0.950/0.037	1.900/0.075

Suggested Pad Layout (Cont.)

(3) Package Type: SOT89

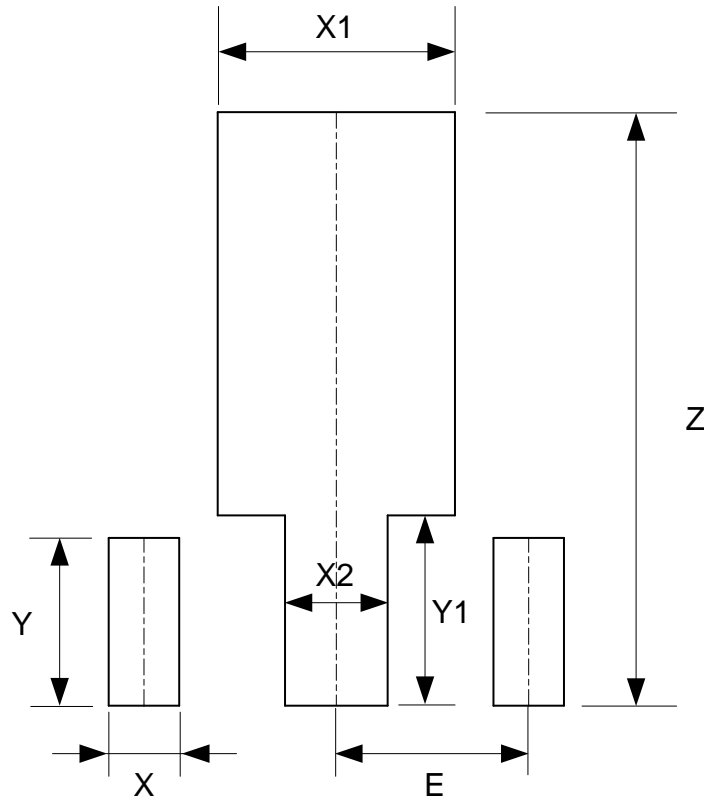

Dimensions	Z (mm)/(inch)	X (mm)/(inch)	X1 (mm)/(inch)	X2 (mm)/(inch)	Y (mm)/(inch)	Y1 (mm)/(inch)	E (mm)/(inch)
Value	4.600/0.181	0.550/0.022	1.850/0.073	0.800/0.031	1.300/0.051	1.475/0.058	1.500/0.059

IMPORTANT NOTICE

DIODES INCORPORATED MAKES NO WARRANTY OF ANY KIND, EXPRESS OR IMPLIED, WITH REGARDS TO THIS DOCUMENT, INCLUDING, BUT NOT LIMITED TO, THE IMPLIED WARRANTIES OF MERCHANTABILITY AND FITNESS FOR A PARTICULAR PURPOSE (AND THEIR EQUIVALENTS UNDER THE LAWS OF ANY JURISDICTION).

Diodes Incorporated and its subsidiaries reserve the right to make modifications, enhancements, improvements, corrections or other changes without further notice to this document and any product described herein. Diodes Incorporated does not assume any liability arising out of the application or use of this document or any product described herein; neither does Diodes Incorporated convey any license under its patent or trademark rights, nor the rights of others. Any Customer or user of this document or products described herein in such applications shall assume all risks of such use and will agree to hold Diodes Incorporated and all the companies whose products are represented on Diodes Incorporated website, harmless against all damages.

Diodes Incorporated does not warrant or accept any liability whatsoever in respect of any products purchased through unauthorized sales channel. Should Customers purchase or use Diodes Incorporated products for any unintended or unauthorized application, Customers shall indemnify and hold Diodes Incorporated and its representatives harmless against all claims, damages, expenses, and attorney fees arising out of, directly or indirectly, any claim of personal injury or death associated with such unintended or unauthorized application.

Products described herein may be covered by one or more United States, international or foreign patents pending. Product names and markings noted herein may also be covered by one or more United States, international or foreign trademarks.

This document is written in English but may be translated into multiple languages for reference. Only the English version of this document is the final and determinative format released by Diodes Incorporated.

LIFE SUPPORT

Diodes Incorporated products are specifically not authorized for use as critical components in life support devices or systems without the express written approval of the Chief Executive Officer of Diodes Incorporated. As used herein:

A. Life support devices or systems are devices or systems which:

1. are intended to implant into the body, or
2. support or sustain life and whose failure to perform when properly used in accordance with instructions for use provided in the labeling can be reasonably expected to result in significant injury to the user.

B. A critical component is any component in a life support device or system whose failure to perform can be reasonably expected to cause the failure of the life support device or to affect its safety or effectiveness.

Customers represent that they have all necessary expertise in the safety and regulatory ramifications of their life support devices or systems, and acknowledge and agree that they are solely responsible for all legal, regulatory and safety-related requirements concerning their products and any use of Diodes Incorporated products in such safety-critical, life support devices or systems, notwithstanding any devices- or systems-related information or support that may be provided by Diodes Incorporated. Further, Customers must fully indemnify Diodes Incorporated and its representatives against any damages arising out of the use of Diodes Incorporated products in such safety-critical, life support devices or systems.

Copyright © 2018, Diodes Incorporated

www.diodes.com

Looking for pricing, stock, or lifecycle information?

Click below to explore more details on WIN SOURCE:

 [View AZ431LANTR-G1 on WIN SOURCE](#)

 [Diodes Incorporated](#) Information

Optimize Your Supply Chain with WIN SOURCE Solutions

-  Global Sourcing Solution
-  Obsolete Management
-  Cost Control Management
-  Shortage Management
-  Alternative Solution
-  Excess Inventory Management