



**THE DATASHEET OF
AD9229BCPZ-65**



FEATURES

- Four ADCs in 1 package**
- Serial LVDS digital output data rates to 780 Mbps (ANSI-644)**
- Data and frame clock outputs**
- SNR = 69.5 dB (to Nyquist)**
- Excellent linearity**
 - DNL = ± 0.3 LSB (typical)**
 - INL = ± 0.4 LSB (typical)**
- 400 MHz full power analog bandwidth**
- Power dissipation**
 - 1,350 mW at 65 MSPS**
 - 985 mW at 50 MSPS**
- 1 V p-p to 2 V p-p input voltage range**
- 3.0 V supply operation**
- Power-down mode**
- Digital test pattern enable for timing alignments**

APPLICATIONS

- Digital beam-forming systems for ultrasound**
- Wireless and wired broadband communications**
- Communication test equipment**

GENERAL DESCRIPTION

The AD9229 is a quad, 12-bit, 65 MSPS analog-to-digital converter (ADC) with an on-chip sample-and-hold circuit that is designed for low cost, low power, small size, and ease of use. The product operates at up to a 65 MSPS conversion rate and is optimized for outstanding dynamic performance in applications where a small package size is critical.

The ADC requires a single 3 V power supply and TTL-/CMOS-compatible sample rate clock for full performance operation. No external reference or driver components are required for many applications.

The ADC automatically multiplies the sample rate clock for the appropriate LVDS serial data rate. A data clock (DCO) for capturing data on the output and a frame clock (FCO) trigger for signaling a new output byte are provided. Power-down is supported and typically consumes 3 mW when enabled.

Fabricated with an advanced CMOS process, the AD9229 is available in a Pb-free, 48-lead LFCSP package. It is specified over the industrial temperature range of -40°C to $+85^{\circ}\text{C}$.

Rev. C

Information furnished by Analog Devices is believed to be accurate and reliable. However, no responsibility is assumed by Analog Devices for its use, nor for any infringements of patents or other rights of third parties that may result from its use. Specifications subject to change without notice. No license is granted by implication or otherwise under any patent or patent rights of Analog Devices. Trademarks and registered trademarks are the property of their respective owners.

FUNCTIONAL BLOCK DIAGRAM

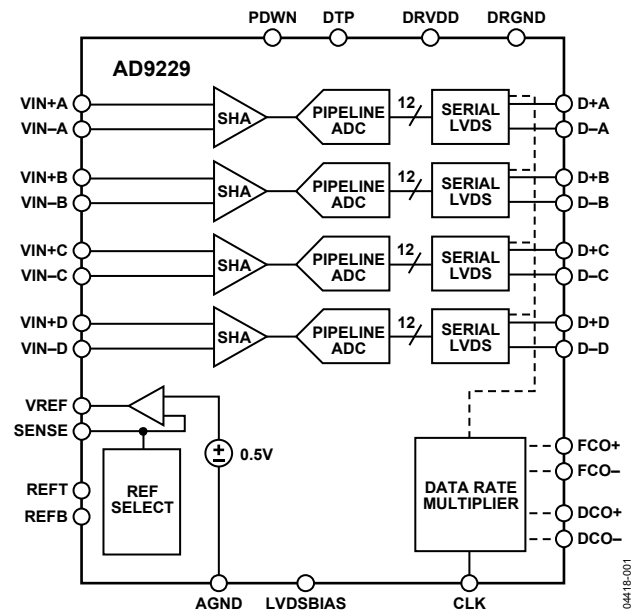

Figure 1.

PRODUCT HIGHLIGHTS

1. Four ADCs are contained in a small, space-saving package.
2. A data clock out (DCO) is provided, which operates up to 390 MHz and supports double-data rate operation (DDR).
3. The outputs of each ADC are serialized LVDS with data rates up to 780 Mbps (12 bits \times 65 MSPS).
4. The AD9229 operates from a single 3.0 V power supply.
5. Packaged in a Pb-free, 48-lead LFCSP package.
6. The internal clock duty cycle stabilizer maintains performance over a wide range of input clock duty cycles.

TABLE OF CONTENTS

Features	1	Equivalent Circuits.....	10
Applications	1	Typical Performance Characteristics	11
Functional Block Diagram	1	Terminology.....	16
General Description	1	Theory of Operation	18
Revision History	2	Analog Input Considerations	18
Specifications	3	Clock Input Considerations	19
AC Specifications	4	Evaluation Board.....	24
Digital Specifications	5	Power Supplies	24
Switching Specifications.....	6	Input Signals	24
Timing Diagram	7	Output Signals	24
Absolute Maximum Ratings	8	Default Operation and Jumper Selection Settings	25
Explanation of Test Levels	8	Alternate Analog Input Drive Configuration	25
ESD Caution.....	8	Outline Dimensions.....	39
Pin Configuration and Function Descriptions	9	Ordering Guide	39

REVISION HISTORY

9/2020—Rev. B to Rev. C

Changed CP-48-8 to CP-48-9.....	Throughout
Changes to Figure 3.....	9
Updated Outline Dimensions.....	39
Changes to Ordering Guide.....	39

5/2010—Rev. A to Rev. B

Change to Item 47 in Table 11.....	38
Updated Outline Dimensions.....	39
Change to Ordering Guide.....	39

9/2005—Rev. 0 to Rev. A

Change to Specifications	3
Changes to Differential Input Configurations Section	19
Changes to Exposed Paddle Thermal Heat Slug Recommendations Section.....	23
Changes to Evaluation Board Section	24
Changes to Table 11	36

3/2005—Revision 0: Initial Version

SPECIFICATIONS

AVDD = 3.0 V, DRVDD = 3.0 V, maximum conversion rate, 2 V p-p differential input, 1.0 V internal reference, AIN = -0.5 dBFS, unless otherwise noted.

Table 1.

Parameter	Temperature	Test Level	AD9229-50			AD9229-65			Unit
			Min	Typ	Max	Min	Typ	Max	
RESOLUTION			12			12			Bits
ACCURACY			Guaranteed			Guaranteed			
No Missing Codes	Full	VI	Guaranteed			Guaranteed			
Offset Error	Full	VI	±5		±25	±5		±25	mV
Offset Matching	Full	VI	±5		±25	±5		±25	mV
Gain Error ¹	Full	VI	±0.3		±2.5	±0.3		±2.5	% FS
Gain Matching ¹	Full	VI	±0.2		±1.5	±0.2		±1.5	% FS
Differential Nonlinearity (DNL)	25°C	V	±0.3			±0.3			LSB
	Full	VI	±0.3		±0.6	±0.3		±0.7	LSB
Integral Nonlinearity (INL)	25°C	V	±0.6			±0.4			LSB
	Full	VI	±0.6		±1	±0.4		±1	LSB
TEMPERATURE DRIFT									
Offset Error	Full	V	±2			±3			ppm/°C
Gain Error ¹	Full	V	±12			±12			ppm/°C
Reference Voltage, VREF = 1 V	Full	V	±16			±16			ppm/°C
REFERENCE									
Output Voltage Error, VREF = 1 V	Full	VI	±10		±30	±10		±30	mV
Load Regulation @ 1.0 mA, VREF = 1 V	Full	V	3			3			mV
Output Voltage Error, VREF = 0.5 V	Full	VI	±8		±17	±8		±17	mV
Load Regulation @ 0.5 mA, VREF = 0.5 V	Full	V	0.2			0.2			mV
Input Resistance	Full	V	7			7			kΩ
ANALOG INPUTS									
Differential Input Voltage Range VREF = 1 V	Full	VI	2			2			V p-p
Differential Input Voltage Range VREF = 0.5 V	Full	VI	1			1			V p-p
Common Mode Voltage	Full	V	1.5			1.5			V
Input Capacitance ²	Full	V	7			7			pF
Analog Bandwidth, Full Power	Full	V	400			400			MHz
POWER SUPPLY									
AVDD	Full	IV	2.7	3.0	3.6	2.7	3.0	3.6	V
DRVDD	Full	IV	2.7	3.0	3.6	2.7	3.0	3.6	V
IAVDD	Full	VI		300	330		420	455	mA
DRVDD	Full	VI		28	31		29	33	mA
Power Dissipation ³	Full	VI		985	1083		1350	1465	mW
Power-Down Dissipation	Full	V		3			3		mW
CROSSTALK ⁴	Full	V	-95			-95			dB

¹ Gain error and gain temperature coefficients are based on the ADC only, with a fixed 1.0 V external reference and a 2 V p-p differential analog input.

² Input capacitance refers to the effective capacitance between one differential input pin and AGND. Refer to Figure 4 for the equivalent analog input structure.

³ Power dissipation measured with rated encode and 2.4 MHz analog input at -0.5 dBFS.

⁴ Typical specification over the first Nyquist zone.

AC SPECIFICATIONS

AVDD = 3.0 V, DRVDD = 3.0 V, maximum conversion rate, 2 V p-p differential input, 1.0 V internal reference, AIN = -0.5 dBFS, unless otherwise noted.

Table 2.

Parameter		Temperature	Test Level	AD9229-50			AD9229-65			Unit
				Min	Typ	Max	Min	Typ	Max	
SIGNAL-TO-NOISE RATIO (SNR)	$f_{IN} = 2.4$ MHz	Full	IV	69.5	70.4		69.0	70.2		dB
	$f_{IN} = 10.3$ MHz	25°C	V		70.4			70.2		dB
	$f_{IN} = 25$ MHz	Full	VI	68.7	69.6					dB
	$f_{IN} = 30$ MHz	Full	VI				68.0	69.5		dB
	$f_{IN} = 70$ MHz	25°C	V		67.2			67.1		dB
SIGNAL-TO-NOISE RATIO (SINAD)	$f_{IN} = 2.4$ MHz	Full	V		70.0			69.8		dB
	$f_{IN} = 10.3$ MHz	25°C	V		70.0			69.8		dB
	$f_{IN} = 25$ MHz	Full	VI	68.4	69.4					dB
	$f_{IN} = 30$ MHz	Full	VI				67.3	69.0		dB
	$f_{IN} = 70$ MHz	25°C	V		66.8			66.7		dB
EFFECTIVE NUMBER OF BITS (ENOB)	$f_{IN} = 2.4$ MHz	Full	V		11.3			11.3		Bits
	$f_{IN} = 10.3$ MHz	25°C	V		11.3			11.3		Bits
	$f_{IN} = 25$ MHz	Full	VI	11.1	11.2					Bits
	$f_{IN} = 30$ MHz	Full	VI				10.9	11.2		Bits
	$f_{IN} = 70$ MHz	25°C	V		10.8			10.8		Bits
SPURIOUS-FREE DYNAMIC RANGE (SFDR)	$f_{IN} = 2.4$ MHz	Full	V		85			85		dBc
	$f_{IN} = 10.3$ MHz	25°C	V		85			85		dBc
	$f_{IN} = 25$ MHz	Full	VI	76	85					dBc
	$f_{IN} = 30$ MHz	Full	VI				73	85		dBc
	$f_{IN} = 70$ MHz	25°C	V		78			77		dBc
WORST HARMONIC (Second or Third)	$f_{IN} = 2.4$ MHz	Full	V		-85			-85		dBc
	$f_{IN} = 10.3$ MHz	25°C	V		-85			-85		dBc
	$f_{IN} = 25$ MHz	Full	VI		-85	-76				dBc
	$f_{IN} = 30$ MHz	Full	VI					-85	-73	dBc
	$f_{IN} = 70$ MHz	25°C	V		-78			-77		dBc
WORST OTHER (Excluding Second or Third)	$f_{IN} = 2.4$ MHz	Full	V		-90			-90		dBc
	$f_{IN} = 10.3$ MHz	25°C	V		-90			-90		dBc
	$f_{IN} = 25$ MHz	Full	VI		-88	-81.7				dBc
	$f_{IN} = 30$ MHz	Full	VI					-88	-79.7	dBc
	$f_{IN} = 70$ MHz	25°C	V		-85			-83		dBc
TWO-TONE INTERMODULATION DISTORTION (IMD) AIN1 and AIN2 = -7.0 dBFS	$f_{IN1} = 15$ MHz	25°C	V		-73			-73		dBc
	$f_{IN2} = 16$ MHz $f_{IN1} = 69$ MHz $f_{IN2} = 70$ MHz	25°C	V		-68.5			-68.5		dBc

DIGITAL SPECIFICATIONS

AVDD = 3.0 V, DRVDD = 3.0 V, maximum conversion rate, 2 V p-p differential input, 1.0 V internal reference, AIN = -0.5 dBFS, unless otherwise noted.

Table 3.

Parameter	Temperature	Test Level	AD9229-50			AD9229-65			Unit
			Min	Typ	Max	Min	Typ	Max	
CLOCK INPUT									
Logic Compliance			TTL/CMOS			TTL/CMOS			
High Level Input Voltage	Full	IV	2.0			2.0			V
Low Level Input Voltage	Full	IV			0.8			0.8	V
High Level Input Current	Full	VI		0.5	±10		0.5	±10	µA
Low Level Input Current	Full	VI		0.5	±10		0.5	±10	µA
Input Capacitance	25°C	V		2			2		pF
LOGIC INPUTS (PDWN)									
Logic 1 Voltage	Full	IV	2.0			2.0			V
Logic 0 Voltage	Full	IV			0.8			0.8	V
High Level Input Current	Full	IV		0.5	±10		0.5	±10	µA
Low Level Input Current	Full	IV		0.5	±10		0.5	±10	µA
Input Capacitance	25°C	V		2			2		pF
DIGITAL OUTPUTS (D+, D-)									
Logic Compliance			LVDS			LVDS			
Differential Output Voltage	Full	VI	260		440	260		440	mV
Output Offset Voltage	Full	VI	1.15	1.25	1.35	1.15	1.25	1.35	V
Output Coding	Full	VI		Offset binary			Offset binary		

AD9229

SWITCHING SPECIFICATIONS

AVDD = 3.0 V, DRVDD = 3.0 V, maximum conversion rate, 2 V p-p differential input, 1.0 V internal reference, AIN = -0.5 dBFS, unless otherwise noted.

Table 4.

Parameter	Temp	Test Level	AD9229-50			AD9229-65			Unit
			Min	Typ	Max	Min	Typ	Max	
CLOCK									
Maximum Clock Rate	Full	VI	50			65			MSPS
Minimum Clock Rate	Full	IV			10			10	MSPS
Clock Pulse Width High (t _{EH})	Full	VI	8	10		6.2	7.7		ns
Clock Pulse Width Low (t _{EL})	Full	VI	8	10		6.2	7.7		ns
OUTPUT PARAMETERS									
Propagation Delay (t _{PD})	Full	VI	3.3	6.5	7.9	3.3	6.5	7.9	ns
Rise Time (t _r) (20% to 80%)	Full	V		250			250		ps
Fall Time (t _f) (20% to 80%)	Full	V		250			250		ps
FCO Propagation Delay (t _{FCO})	Full	V		6.5			6.5		ns
DCO Propagation Delay (t _{CPD})	Full	V		t _{FCO} + (t _{SAMPLE/24})			t _{FCO} + (t _{SAMPLE/24})		ns
DCO-to-Data Delay (t _{DATA})	Full	IV	(t _{SAMPLE/24}) - 250	(t _{SAMPLE/24})	(t _{SAMPLE/24}) + 250	(t _{SAMPLE/24}) - 250	(t _{SAMPLE/24})	(t _{SAMPLE/24}) + 250	ps
DCO-to-FCO Delay (t _{FRAME})	Full	IV	(t _{SAMPLE/24}) - 250	(t _{SAMPLE/24})	(t _{SAMPLE/24}) + 250	(t _{SAMPLE/24}) - 250	(t _{SAMPLE/24})	(t _{SAMPLE/24}) + 250	ps
Data-to-Data Skew (t _{DATA-MAX} - t _{DATA-MIN})	Full	IV		±100	±250		±100	±250	ps
Wake-Up Time	25°C	V		4			4		ms
Pipeline Latency	Full	IV		10			10		CLK cycles
APERTURE									
Aperture Delay (t _A)	25°C	V		1.8			1.8		ns
Aperture Uncertainty (Jitter)	25°C	V		<1			<1		ps rms
OUT-OF-RANGE RECOVERY TIME	25°C	V		2			2		CLK cycles

TIMING DIAGRAM

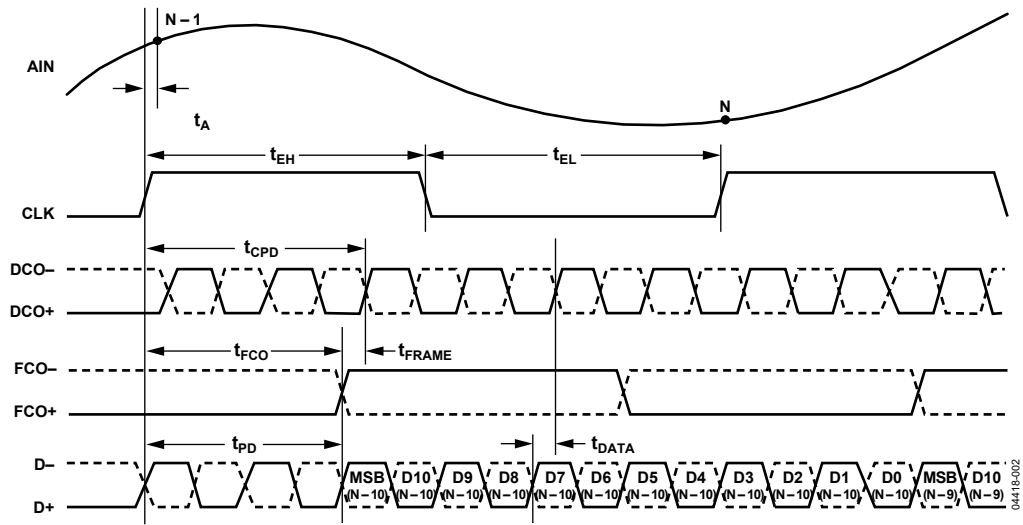

Figure 2. Timing Diagram

ABSOLUTE MAXIMUM RATINGS

Table 5.

Parameter	With Respect To	Rating
ELECTRICAL		
AVDD	AGND	-0.3 V to +3.9 V
DRVDD	DRGND	-0.3 V to +3.9 V
AGND	DRGND	-0.3 V to +0.3 V
AVDD	DRVDD	-3.9 V to +3.9 V
Digital Outputs (D+, D-, DCO+, DCO-, FCO+, FCO-)	DRGND	-0.3 V to DRVDD
LVDSBIAS	DRGND	-0.3 V to DRVDD
CLK	AGND	-0.3 V to AVDD
VIN+, VIN-	AGND	-0.3 V to AVDD
PDWN, DTP	AGND	-0.3 V to AVDD
REFT, REFB	AGND	-0.3 V to AVDD
VREF, SENSE	AGND	-0.3 V to AVDD
ENVIRONMENTAL		
Operating Temperature Range (Ambient)		-40°C to +85°C
Maximum Junction Temperature		150°C
Lead Temperature (Soldering, 10 sec)		300°C
Storage Temperature Range (Ambient)		-65°C to +150°C
Thermal Impedance ¹		25°C/W

Stresses above those listed under Absolute Maximum Ratings may cause permanent damage to the device. This is a stress rating only; functional operation of the device at these or any other conditions above those indicated in the operational section of this specification is not implied. Exposure to absolute maximum rating conditions for extended periods may affect device reliability.

EXPLANATION OF TEST LEVELS

- I. 100% production tested.
- II. 100% production tested at 25°C and guaranteed by design and characterization at specified temperatures.
- III. Sample tested only.
- IV. Parameter is guaranteed by design and characterization testing.
- V. Parameter is a typical value only.
- VI. 100% production tested at 25°C and guaranteed by design and characterization for industrial temperature range.

¹ θ_{JA} for a 4-layer PCB with a solid ground plane in still air.

ESD CAUTION

ESD (electrostatic discharge) sensitive device. Electrostatic charges as high as 4000 V readily accumulate on the human body and test equipment and can discharge without detection. Although this product features proprietary ESD protection circuitry, permanent damage may occur on devices subjected to high energy electrostatic discharges. Therefore, proper ESD precautions are recommended to avoid performance degradation or loss of functionality.



PIN CONFIGURATION AND FUNCTION DESCRIPTIONS

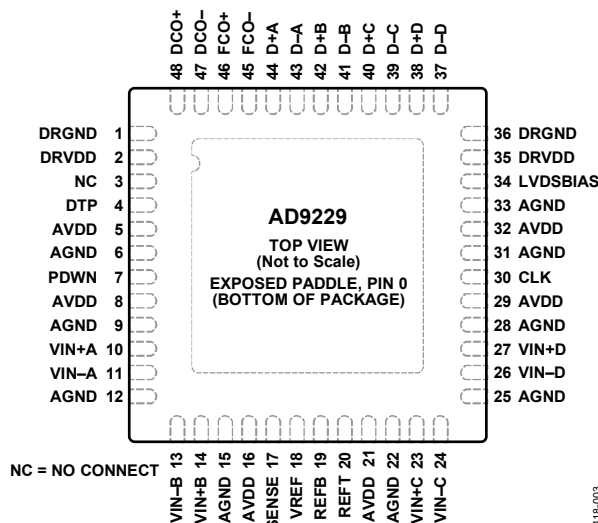

Figure 3. LFCSP Top View

Table 6. Pin Function Descriptions

Pin No.	Mnemonic	Description	Pin No.	Mnemonic	Description
5, 8, 16, 21, 29, 32	AVDD	Analog Supply	26	VIN-D	ADC D Analog Input—Complement
6, 9, 12, 15, 22, 25, 28, 31, 33	AGND	Analog Ground	27	VIN+D	ADC D Analog Input—True
2, 35	DRVDD	Digital Output Supply	30	CLK	Input Clock
1, 36	DRGND	Digital Ground	34	LVDSBIAS	LVDS Output Current Set Resistor Pin
0	AGND	Exposed Paddle/Thermal Heat Slug (Located on Bottom of Package)	37	D-D	ADC D Complement Digital Output
3	NC	No Connect	38	D+D	ADC D True Digital Output
4	DTP	Digital Test Pattern Enable	39	D-C	ADC C Complement Digital Output
7	PDWN	Power-Down Selection (AVDD = Power Down)	40	D+C	ADC C True Digital Output
10	VIN+A	ADC A Analog Input—True	41	D-B	ADC B Complement Digital Output
11	VIN-A	ADC A Analog Input—Complement	42	D+B	ADC B True Digital Output
13	VIN-B	ADC B Analog Input—Complement	43	D-A	ADC A Complement Digital Output
14	VIN+B	ADC B Analog Input—True	44	D+A	ADC A True Digital Output
17	SENSE	Reference Mode Selection	45	FCO-	Frame Clock Indicator—Complement Output
18	VREF	Voltage Reference Input/Output	46	FCO+	Frame Clock Indicator—True Output
19	REFB	Differential Reference (Bottom)	47	DCO-	Data Clock Output—Complement
20	REFT	Differential Reference (Top)	48	DCO+	Data Clock Output—True
23	VIN+C	ADC C Analog Input—True			
24	VIN-C	ADC C Analog Input—Complement			

EQUIVALENT CIRCUITS

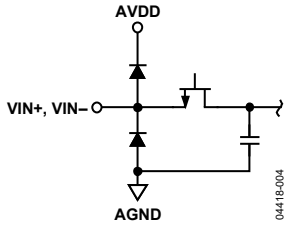

Figure 4. Equivalent Analog Input Circuit

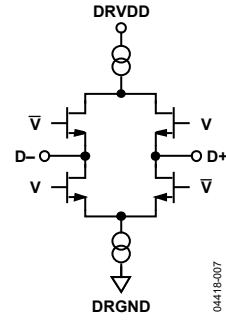

Figure 7. Equivalent Digital Output Circuit

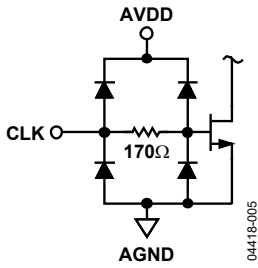

Figure 5. Equivalent Clock Input Circuit

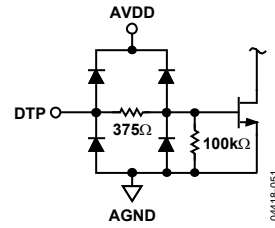

Figure 8. Equivalent DTP Input Circuit

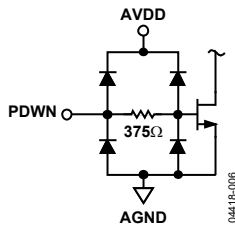

Figure 6. Equivalent Digital Input Circuit

TYPICAL PERFORMANCE CHARACTERISTICS

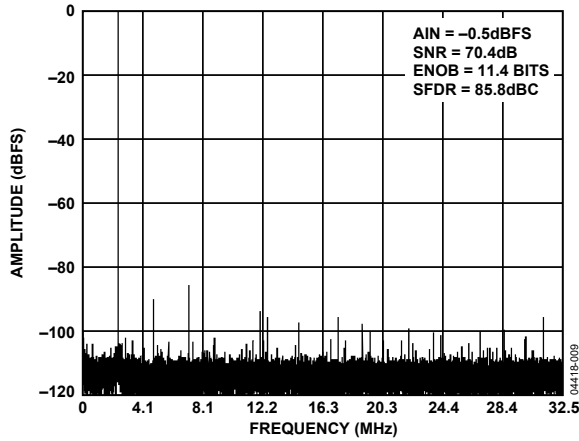

Figure 9. Single-Tone 32k FFT with $f_{IN} = 2.4$ MHz, $f_{SAMPLE} = 65$ MSPS

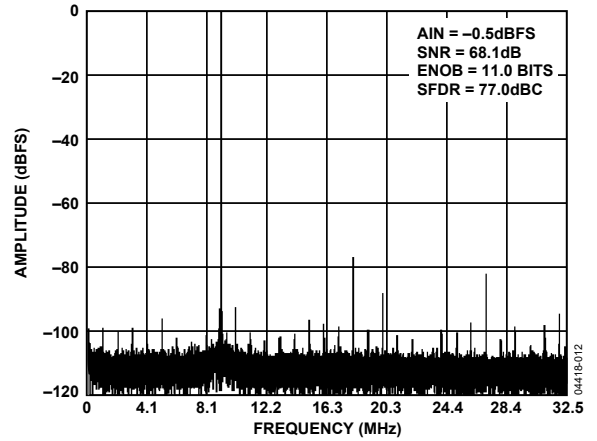

Figure 12. Single-Tone 32k FFT with $f_{IN} = 120$ MHz, $f_{SAMPLE} = 65$ MSPS

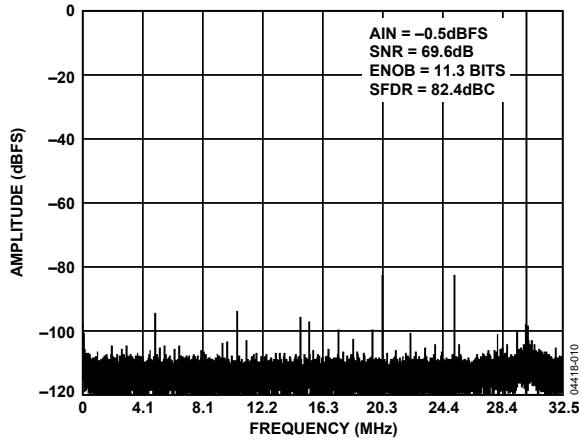

Figure 10. Single-Tone 32k FFT with $f_{IN} = 30$ MHz, $f_{SAMPLE} = 65$ MSPS

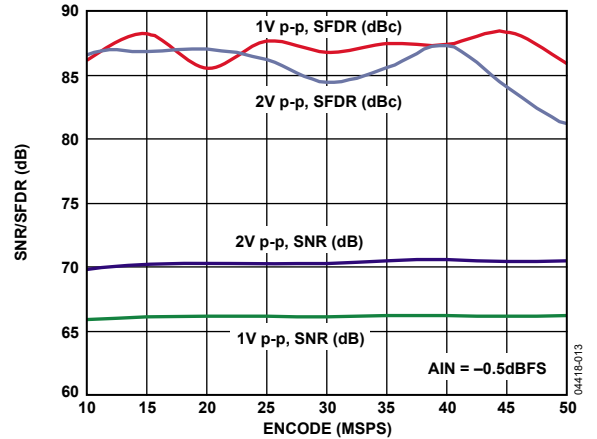

Figure 13. SNR/SFDR vs. f_{SAMPLE} , $f_{IN} = 10.3$ MHz, $f_{SAMPLE} = 50$ MSPS

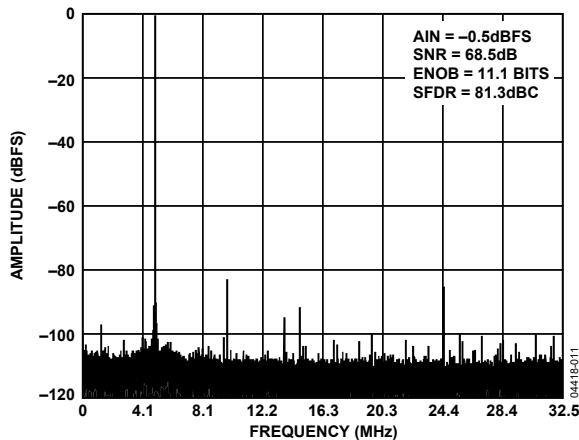

Figure 11. Single-Tone 32k FFT with $f_{IN} = 70$ MHz, $f_{SAMPLE} = 65$ MSPS

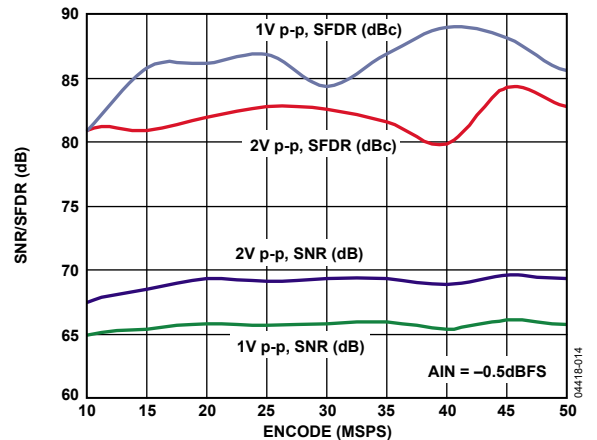

Figure 14. SNR/SFDR vs. f_{SAMPLE} , $f_{IN} = 25$ MHz, $f_{SAMPLE} = 50$ MSPS

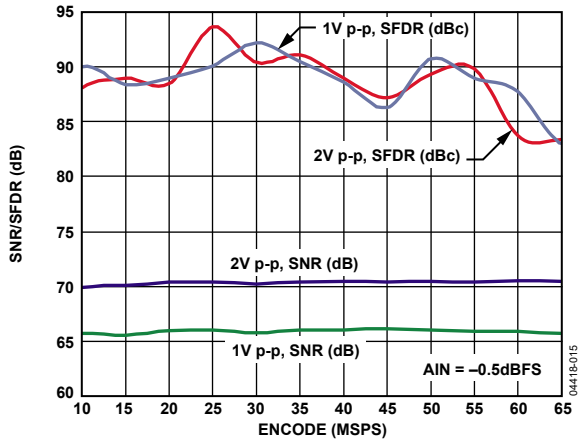

Figure 15. SNR/SFDR vs. f_{SAMPLE} , $f_{IN} = 10.3$ MHz, $f_{SAMPLE} = 65$ MSPS

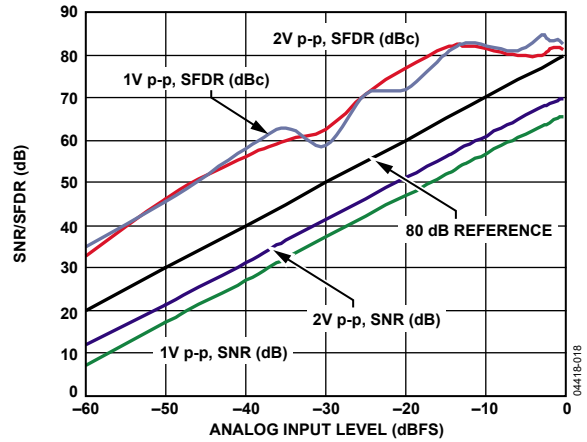

Figure 18. SNR/SFDR vs. Analog Input Level, $f_{IN} = 25$ MHz, $f_{SAMPLE} = 50$ MSPS

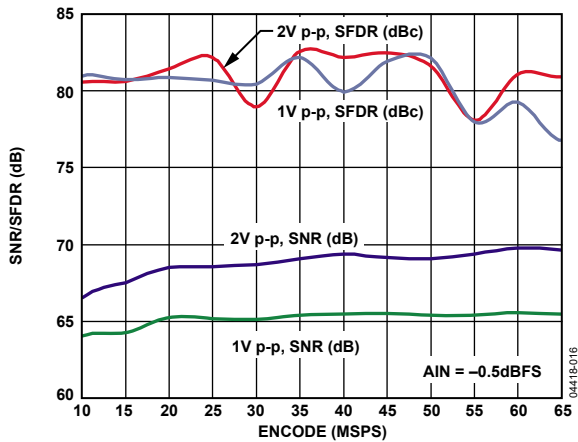

Figure 16. SNR/SFDR vs. f_{SAMPLE} , $f_{IN} = 30$ MHz, $f_{SAMPLE} = 65$ MSPS

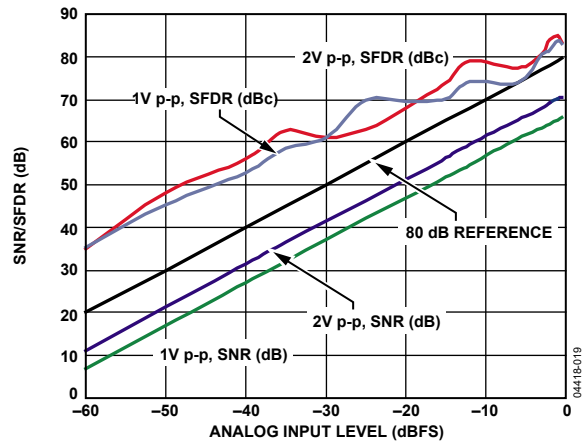

Figure 19. SNR/SFDR vs. Analog Input Level, $f_{IN} = 10.3$ MHz, $f_{SAMPLE} = 65$ MSPS

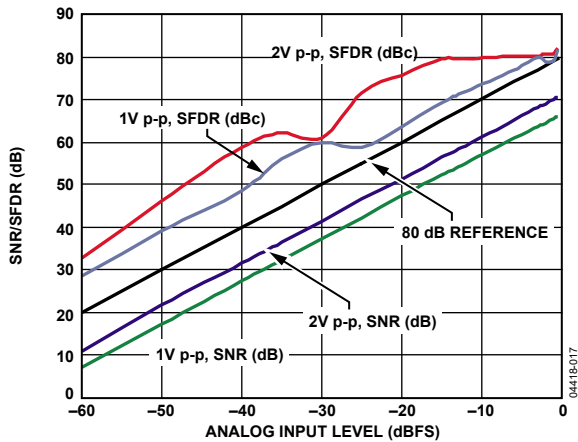

Figure 17. SNR/SFDR vs. Analog Input Level, $f_{IN} = 10.3$ MHz, $f_{SAMPLE} = 50$ MSPS

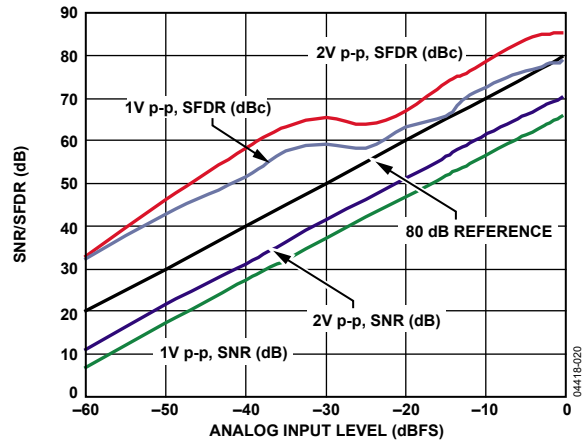

Figure 20. SNR/SFDR vs. Analog Input Level, $f_{IN} = 30$ MHz, $f_{SAMPLE} = 65$ MSPS

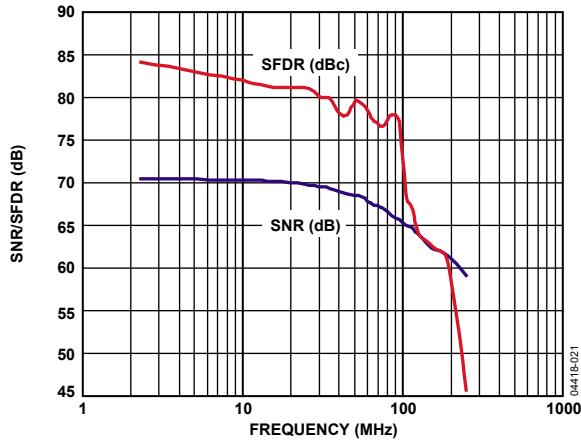

Figure 21. SNR/SFDR vs. f_{IN} , $f_{SAMPLE} = 65$ MHz

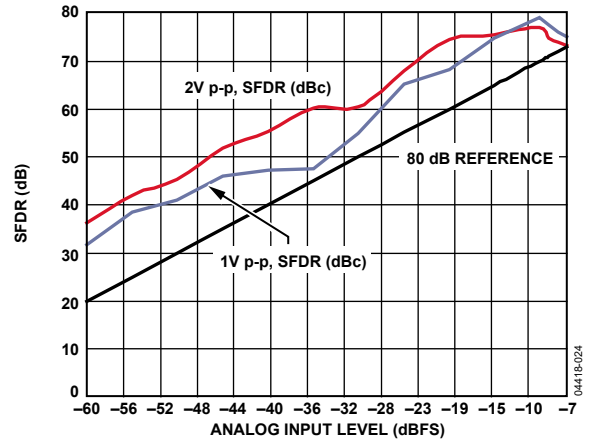

Figure 24. Two-Tone SFDR vs. Analog Input Level, $f_{IN1} = 15$ MHz and $f_{IN2} = 16$ MHz, $f_{SAMPLE} = 65$ MSPS

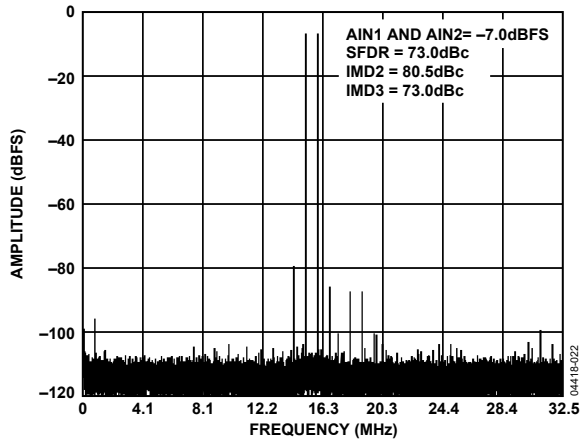

Figure 22. Two-Tone 32k FFT with $f_{IN1} = 15$ MHz and $f_{IN2} = 16$ MHz, $f_{SAMPLE} = 65$ MSPS

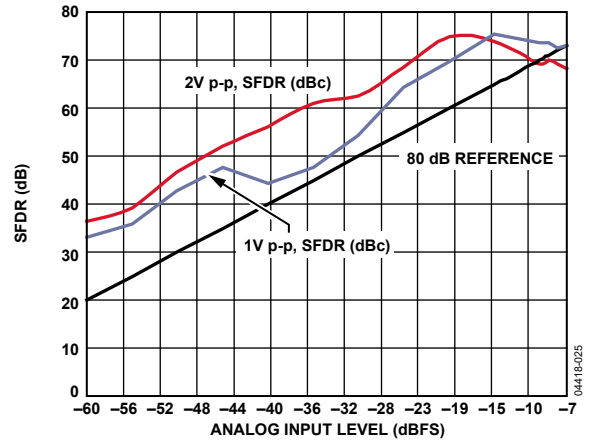

Figure 25. Two-Tone SFDR vs. Analog Input Level, $f_{IN1} = 69$ MHz and $f_{IN2} = 70$ MHz, $f_{SAMPLE} = 65$ MSPS

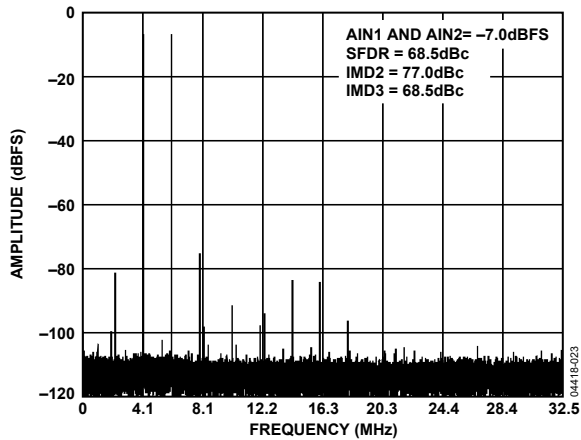

Figure 23. Two-Tone 32k FFT with $f_{IN1} = 69$ MHz and $f_{IN2} = 70$ MHz, $f_{SAMPLE} = 65$ MSPS

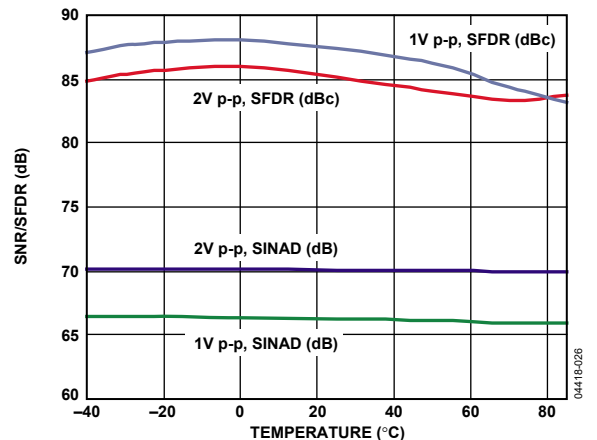

Figure 26. SINAD/SFDR vs. Temperature, $f_{IN} 10.3$ MHz, $f_{SAMPLE} = 65$ MSPS

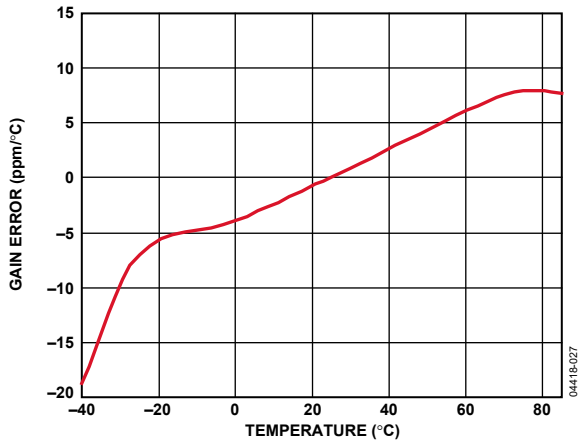

Figure 27. Gain Error vs. Temperature

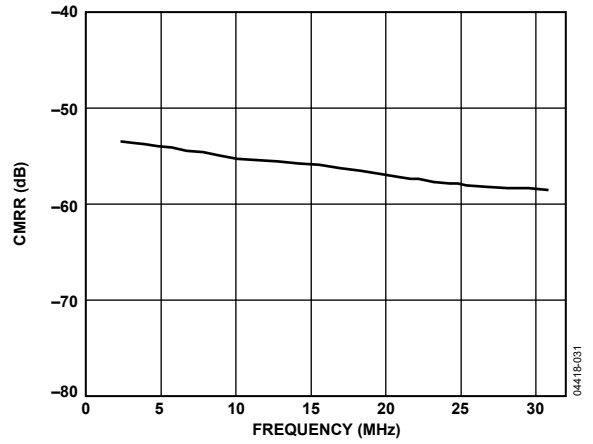

Figure 30. CMRR vs. Frequency, $f_{\text{SAMPLE}} = 65 \text{ MSPS}$

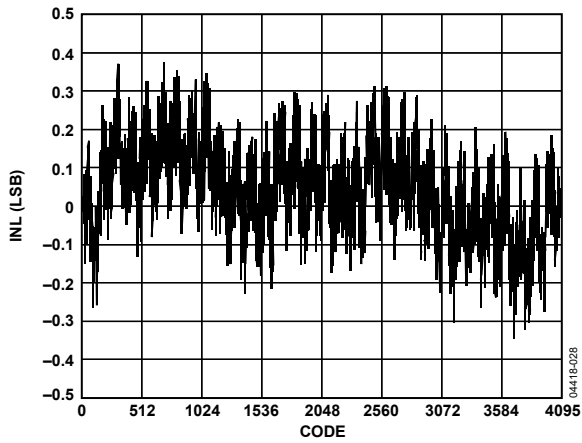

Figure 28. Typical INL, $f_{\text{IN}} = 2.4 \text{ MHz}$, $f_{\text{SAMPLE}} = 65 \text{ MSPS}$

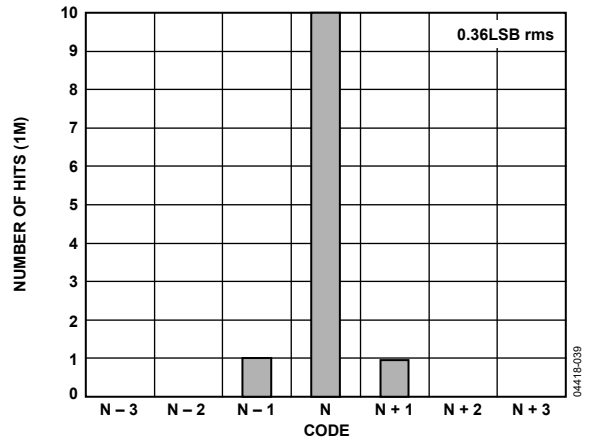

Figure 31. Input Referred Noise Histogram, $f_{\text{SAMPLE}} = 65 \text{ MSPS}$

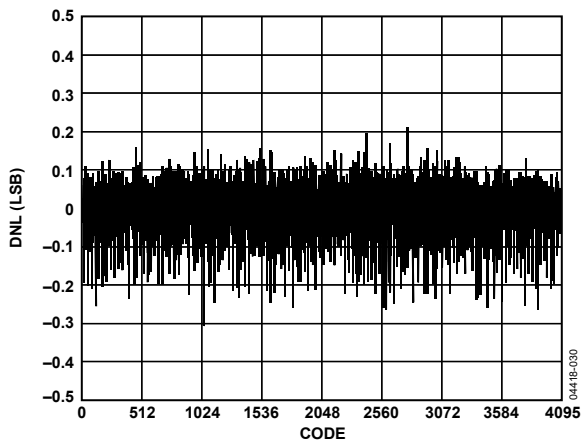

Figure 29. Typical DNL, $f_{\text{IN}} = 2.4 \text{ MHz}$, $f_{\text{SAMPLE}} = 65 \text{ MSPS}$

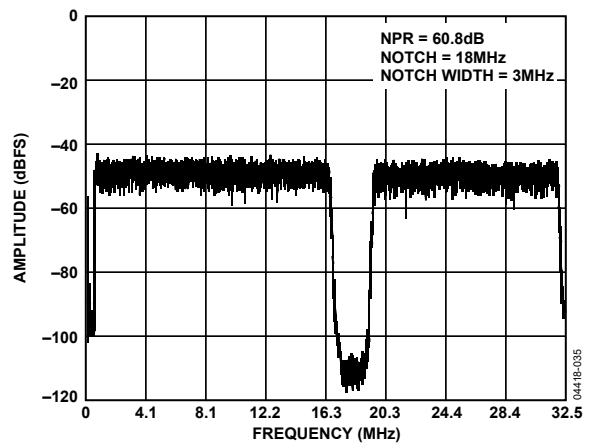

Figure 32. Noise Power Ratio (NPR), $f_{\text{SAMPLE}} = 65 \text{ MSPS}$

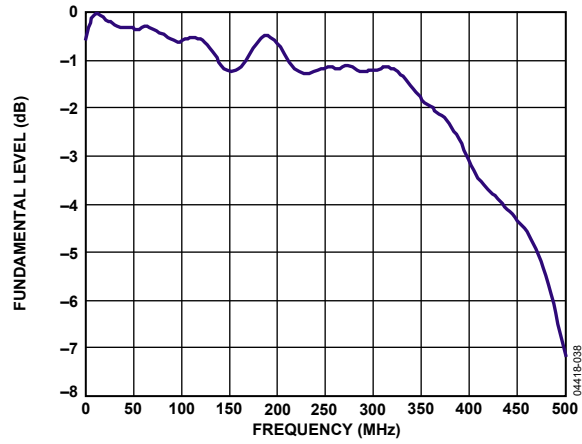

Figure 33. Full Power Bandwidth vs. Frequency, $f_{SAMPLE} = 65$ MSPS

TERMINOLOGY

Analog Bandwidth

Analog bandwidth is the analog input frequency at which the spectral power of the fundamental frequency (as determined by the FFT analysis) is reduced by 3 dB from full scale.

Aperture Delay

Aperture delay is a measure of the sample-and-hold amplifier (SHA) performance and is measured from the 50% point rising edge of the clock input to the time at which the input signal is held for conversion.

Aperture Uncertainty (Jitter)

Aperture jitter is the variation in aperture delay for successive samples and can be manifested as frequency-dependent noise on the ADC input.

Clock Pulse Width and Duty Cycle

Pulse width high is the minimum amount of time that the clock pulse should be left in the Logic 1 state to achieve rated performance. Pulse width low is the minimum time the clock pulse should be left in the low state. At a given clock rate, these specifications define an acceptable clock duty cycle.

Common Mode Rejection Ratio (CMRR)

CMRR is defined as the amount of rejection on the differential analog inputs when a common signal is applied. Typically expressed as 20 log (differential gain/common-mode gain).

Crosstalk

Crosstalk is defined as the measure of any feedthrough coupling onto the quiet channel when all other channels are driven by a full-scale signal.

Differential Analog Input Voltage Range

The peak-to-peak differential voltage that must be applied to the converter to generate a full-scale response. Peak differential voltage is computed by observing the voltage on a pin and subtracting the voltage from a second pin that is 180° out of phase.

Differential Nonlinearity (DNL, No Missing Codes)

An ideal ADC exhibits code transitions that are exactly 1 LSB apart. DNL is the deviation from this ideal value. Guaranteed no missing codes to an n-bit resolution indicates that all 2ⁿ codes, respectively, must be present over all operating ranges.

Effective Number of Bits (ENOB)

For a sine wave, SINAD can be expressed in terms of the number of bits. Using the following formula, it is possible to obtain a measure of performance expressed as N, the effective number of bits:

$$N = (\text{SINAD} - 1.76)/6.02$$

Full Power Bandwidth

Full power bandwidth is the measured –3 dB point at the analog front-end input relative to the frequency measured.

Gain Error

The largest gain error is specified and is considered the difference between the measured and ideal full-scale input voltage range.

Gain Matching

Expressed as a percentage of FSR and computed using the following equation:

$$\text{Gain Matching} = \frac{FSR_{\max} - FSR_{\min}}{\left(\frac{FSR_{\max} + FSR_{\min}}{2}\right)} \times 100\%$$

where FSR_{\max} is the most positive gain error of the ADCs, and FSR_{\min} is the most negative gain error of the ADCs.

Input-Referred Noise

Input-referred noise is a measure of the wideband noise generated by the ADC core. Histograms of the output codes are created while a dc signal is applied to the ADC input. Input-referred noise is calculated using the standard deviation of the histograms and presented in terms of LSB rms.

Integral Nonlinearity (INL)

INL refers to the deviation of each individual code from a line drawn from negative full scale through positive full scale. The point used as negative full scale occurs 0.5 LSB before the first code transition. Positive full scale is defined as a level 1.5 LSB beyond the last code transition. The deviation is measured from the middle of each code to the true straight line.

Noise Power Ratio (NPR)

NPR is the full-scale rms noise power injected into the ADC vs. the rejected band of interest (notch depth measured).

Offset Error

The largest offset error is specified and is considered the difference between the measured and ideal voltage at the analog input that produces the midscale code at the outputs.

Offset Matching

Expressed in millivolts and computed using the following equation:

$$\text{Offset Matching} = \text{OFF}_{\max} - \text{OFF}_{\min}$$

where OFF_{\max} is the most positive offset error, and OFF_{\min} is the most negative offset error.

Out-of-Range Recovery Time

Out-of-range recovery time is the time it takes for the ADC to reacquire the analog input after a transient from 10% above positive full scale to 10% above negative full scale, or from 10% below negative full scale to 10% below positive full scale.

Output Propagation Delay

The delay between the clock logic threshold and the time when all bits are within valid logic levels.

Second and Third Harmonic Distortion

The ratio of the rms signal amplitude to the rms value of the second or third harmonic component, reported in decibels relative to the carrier.

Signal-to Noise and Distortion (SINAD) Ratio

SINAD is the ratio of the rms value of the measured input signal to the rms sum of all other spectral components below the Nyquist frequency, including harmonics but excluding dc. The value for SINAD is expressed in decibels.

Signal-to-Noise Ratio (SNR)

SNR is the ratio of the rms value of the measured input signal to the rms sum of all other spectral components below the Nyquist frequency, excluding the first six harmonics and dc. The value for SNR is expressed in decibels.

Spurious-Free Dynamic Range (SFDR)

SFDR is the difference in decibels between the rms amplitude of the input signal and the peak spurious signal.

Temperature Drift

The temperature drift for offset error and gain error specifies the maximum change from the initial (25°C) value to the value at T_{MIN} or T_{MAX} .

Two-Tone SFDR

The ratio of the rms value of either input tone to the rms value of the peak spurious component. The peak spurious component may or may not be an IMD product. It may be reported in decibels relative to the carrier (that is, degrades as signal levels are lowered) or in decibels relative to full scale (always related back to converter full scale).

THEORY OF OPERATION

The AD9229 architecture consists of a front-end switched capacitor sample-and-hold amplifier (SHA) followed by a pipelined ADC. The pipelined ADC is divided into three sections: a 4-bit first stage followed by eight 1.5-bit stages and a final 3-bit flash. Each stage provides sufficient overlap to correct for flash errors in the preceding stages. The quantized outputs from each stage are combined into a final 12-bit result in the digital correction logic. The pipelined architecture permits the first stage to operate on a new input sample while the remaining stages operate on preceding samples. Sampling occurs on the rising edge of the clock.

Each stage of the pipeline, excluding the last, consists of a low resolution flash ADC connected to a switched capacitor DAC and interstage residue amplifier (MDAC). The residue amplifier magnifies the difference between the reconstructed DAC output and the flash input for the next stage in the pipeline. One bit of redundancy is used in each stage to facilitate digital correction of flash errors. The last stage simply consists of a flash ADC.

The input stage contains a differential SHA that can be configured as ac- or dc-coupled in differential or single-ended modes. The output staging block aligns the data, carries out the error correction, and passes the data to the output buffers. The data is then serialized and aligned to the frame and output clock.

ANALOG INPUT CONSIDERATIONS

The analog input to the AD9229 is a differential switched-capacitor SHA that has been designed for optimum performance while processing a differential input signal. The SHA input can support a wide common-mode range and maintain excellent performance. An input common-mode voltage of midsupply minimizes signal-dependent errors and provides optimum performance.

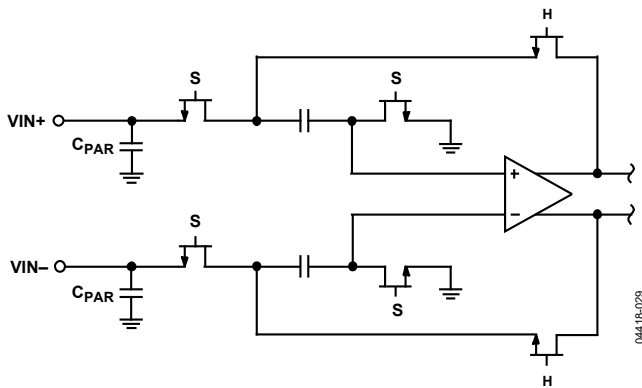

Figure 34. Switched-Capacitor SHA Input

The clock signal alternately switches the SHA between sample mode and hold mode (see Figure 34). When the SHA is switched into sample mode, the signal source must be capable

of charging the sample capacitors and settling within one-half of a clock cycle. A small resistor in series with each input can help reduce the peak transient current required from the output stage of the driving source. Also, a small shunt capacitor can be placed across the inputs to provide dynamic charging currents. This passive network creates a low-pass filter at the ADC's input; therefore, the precise values are dependent on the application.

The analog inputs of the AD9229 are not internally dc-biased. In ac-coupled applications, the user must provide this bias externally. For optimum performance, set the device so that $V_{CM} = AVDD/2$; however, the device can function over a wider range with reasonable performance (see Figure 35 and Figure 36).

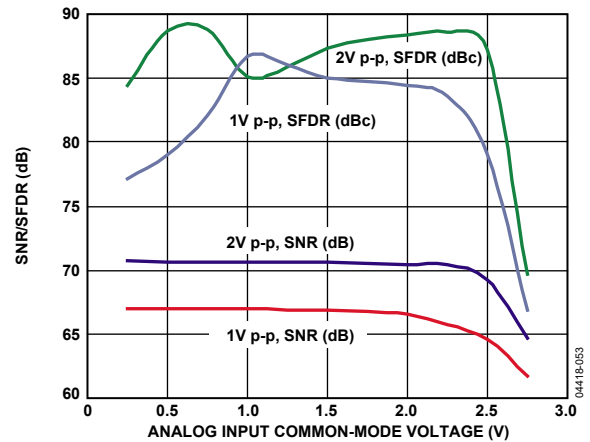

Figure 35. SNR/SFDR vs. Common-Mode Voltage, $f_{IN} = 2.4$ MHz, $f_{SAMPLE} = 65$ MSPS

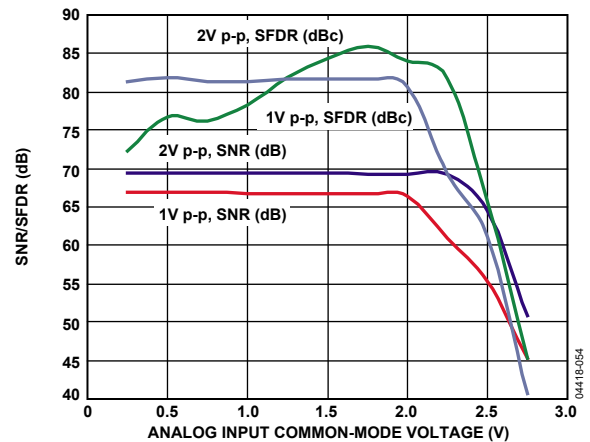

Figure 36. SNR/SFDR vs. Common-Mode Voltage, $f_{IN} = 30$ MHz, $f_{SAMPLE} = 65$ MSPS

For best dynamic performance, the source impedances driving $VIN+$ and $VIN-$ should be matched such that common-mode settling errors are symmetrical. These errors are reduced by the common-mode rejection of the ADC.

An internal reference buffer creates the positive and negative reference voltages, REFT and REFB, respectively, that defines the span of the ADC core. The output common-mode of the reference buffer is set to midsupply, and the REFT and REFB voltages and span are defined as

$$REFT = 1/2 (AVDD + VREF)$$

$$REFB = 1/2 (AVDD - VREF)$$

$$Span = 2 \times (REFT - REFB) = 2 \times VREF$$

It can be seen from the equations above that the REFT and REFB voltages are symmetrical about the midsupply voltage and, by definition, the input span is twice the value of the VREF voltage.

The internal voltage reference can be pin-strapped to fixed values of 0.5 V or 1.0 V or adjusted within the same range, as discussed in the Internal Reference Connection section. Maximum SNR performance is achieved by setting the AD9229 to the largest input span of 2 V p-p.

The SHA should be driven from a source that keeps the signal peaks within the allowable range for the selected reference voltage. The minimum and maximum common-mode input levels are defined in Figure 35 and Figure 36.

Differential Input Configurations

Optimum performance is achieved by driving the AD9229 in a differential input configuration. For ultrasound applications, the AD8332 differential driver provides excellent performance and a flexible interface to the ADC (see Figure 37).

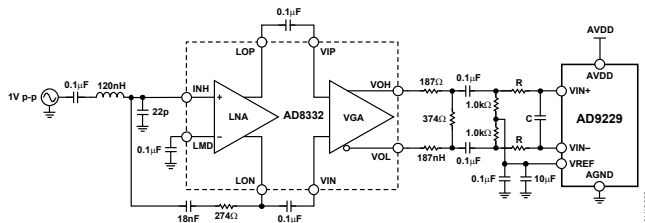

Figure 37. Differential Input Configuration Using the AD8332

However, the noise performance of most amplifiers is not adequate to achieve the true performance of the AD9229. For applications where SNR is a key parameter, differential transformer coupling is the recommended input configuration. An example of this is shown in Figure 38.

In any configuration, the value of the shunt capacitor, C, is dependent on the input frequency and may need to be reduced or removed.

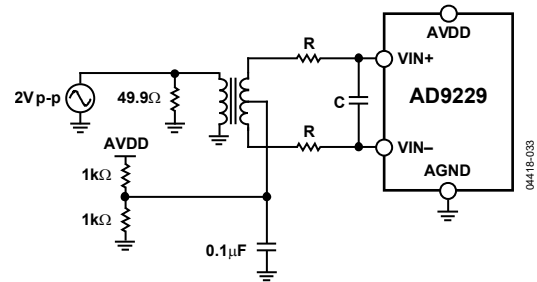

Figure 38. Differential Transformer—Coupled Configuration

Single-Ended Input Configuration

A single-ended input can provide adequate performance in cost-sensitive applications. In this configuration, SFDR and distortion performance degrade due to the large input common-mode swing. However, if the source impedances on each input are matched, there should be little effect on SNR performance. Figure 39 details a typical single-ended input configuration.

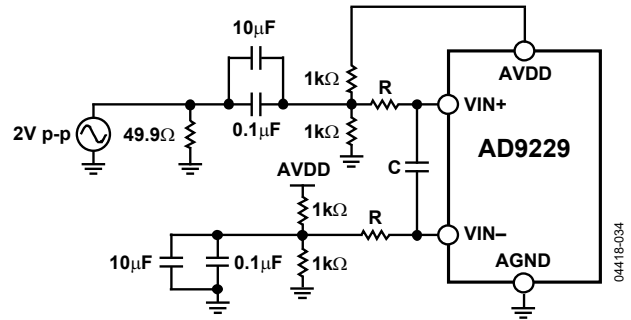

Figure 39. Single-Ended Input Configuration

CLOCK INPUT CONSIDERATIONS

Typical high speed ADCs use both clock edges to generate a variety of internal timing signals and, as a result, may be sensitive to clock duty cycle. Typically, a 10% tolerance is required on the clock duty cycle to maintain dynamic performance characteristics. The AD9229 has a self-contained clock duty cycle stabilizer that retimes the nonsampling edge, providing an internal clock signal with a nominal 50% duty cycle. This allows a wide range of clock input duty cycles without affecting the performance of the AD9229.

An on-board phase-locked loop (PLL) multiplies the input clock rate for the purpose of shifting the serial data out. The stability criteria for the PLL limits the minimum sample clock rate of the ADC to 10 MSPS. Assuming steady state operation of the input clock, any sudden change in the sampling rate could create an out-of-lock condition leading to invalid outputs at the DCO, FCO, and data out pins.

High speed, high resolution ADCs are sensitive to the quality of the clock input. The degradation in SNR at a given full-scale input frequency (f_A) due only to aperture jitter (t_A) can be calculated with the following equation:

$$SNR \text{ degradation} = 20 \times \log_{10} [1/2 \times \pi \times f_A \times t_A]$$

In the equation, the rms aperture jitter, t_A , represents the root sum square of all jitter sources, which include the clock input, analog input signal, and ADC aperture jitter specification. Applications that require undersampling are particularly sensitive to jitter.

The clock input should be treated as an analog signal in cases where aperture jitter may affect the dynamic range of the AD9229. Power supplies for clock drivers should be separated from the ADC output driver supplies to avoid modulating the clock signal with digital noise. Low jitter, crystal-controlled oscillators make the best clock sources. If the clock is generated from another type of source (by gating, dividing, or other methods), it should be retimed by the original clock at the last step.

Power Dissipation and Power-Down Mode

As shown in Figure 40 and Figure 41, the power dissipated by the AD9229 is proportional to its sample rate. The digital power dissipation does not vary much because it is determined primarily by the DRVDD supply and bias current of the LVDS output drivers.

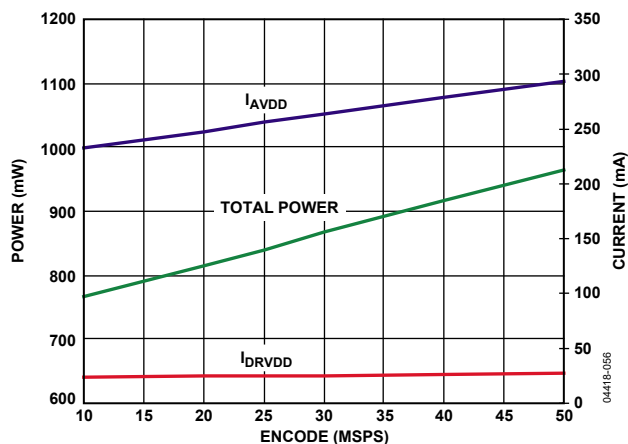

Figure 40. Supply Current vs. f_{SAMPLE} for $f_{IN} = 10.3$ MHz, $f_{SAMPLE} = 50$ MSPS

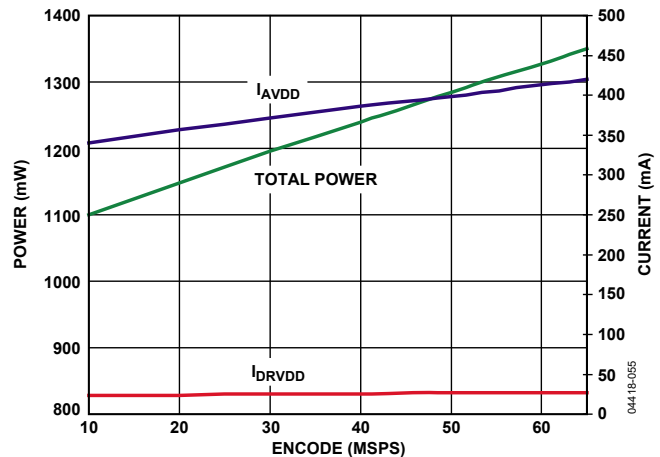

Figure 41. Supply Current vs. f_{SAMPLE} for $f_{IN} = 10.3$ MHz, $f_{SAMPLE} = 65$ MSPS

By asserting the PDWN pin high, the AD9229 is placed in power-down mode. In this state, the ADC typically dissipates 3 mW. During power-down, the LVDS output drivers are placed in a high impedance state. Reasserting the PDWN pin low returns the AD9229 to normal operating mode.

In power-down mode, low power dissipation is achieved by shutting down the reference, reference buffer, PLL, and biasing networks. The decoupling capacitors on REFT and REFB are discharged when entering standby mode and then must be recharged when returning to normal operation. As a result, the wake-up time is related to the time spent in the power-down mode; shorter cycles result in proportionally shorter wake-up times. With the recommended 0.1 μ F and 10 μ F decoupling capacitors on REFT and REFB, it takes approximately 1 sec to fully discharge the reference buffer decoupling capacitors and 4 ms to restore full operation.

Digital Outputs

The AD9229's differential outputs conform to the ANSI-644 LVDS standard. To set the LVDS bias current, place a resistor (RSET is nominally equal to 4.0 k Ω) to ground at the LVDSBIAS pin. The RSET resistor current is derived on-chip and sets the output current at each output equal to a nominal 3.5 mA. A 100 Ω differential termination resistor placed at the LVDS receiver inputs results in a nominal 350 mV swing at the receiver. To adjust the differential signal swing, simply change the resistor to a different value, as shown in Table 7.

Table 7. LVDSBIAS Pin Configuration

RSET	Differential Output Swing
3.7 k Ω	375 mV p-p
4.0 k Ω (default)	350 mV p-p
4.3 k Ω	325 mV p-p

The AD9229's LVDS outputs facilitate interfacing with LVDS receivers in custom ASICs and FPGAs that have LVDS capability for superior switching performance in noisy environments. Single point-to-point net topologies are recommended with a 100 Ω termination resistor placed as close to the receiver as possible. It is recommended to keep the trace length no longer than 12 inches and to keep differential output traces close together and at equal lengths.

The format of the output data is offset binary. An example of the output coding format can be found in Table 8.

Table 8. Digital Output Coding

Code	(VIN+) – (VIN–), Input Span = 2 V p-p (V)	(VIN+) – (VIN–), Input Span = 1 V p-p (V)	Digital Output Offset Binary (D11 ... D0)
4095	1.000	0.500	1111 1111 1111
2048	0	0	1000 0000 0000
2047	–0.000488	–0.000244	0111 1111 1111
0	–1.00	–0.5000	0000 0000 0000

Timing

Data from each ADC is serialized and provided on a separate channel. The data rate for each serial stream is equal to 12 bits times the sample clock rate, with a maximum of 780 bps (12 bits \times 65 MSPS = 780 bps). The lowest typical conversion rate is 10 MSPS.

Two output clocks are provided to assist in capturing data from the AD9229. The DCO is used to clock the output data and is equal to six times the sampling clock (CLK) rate. Data is clocked out of the AD9229 and can be captured on the rising and falling edges of the DCO that supports double-data rate (DDR) capturing. The frame clock out (FCO) is used to signal the start of a new output byte and is equal to the sampling clock rate. See the timing diagram shown in Figure 2 for more information.

DTP Pin

The digital test pattern (DTP) pin can be enabled for two types of test patterns, as summarized in Table 9. When the DTP is tied to AVDD/3, all the ADC channel outputs shift out the following pattern: 1000 0000 0000. When the DTP is tied to 2 \times AVDD/3, all the ADC channel outputs shift out the following pattern: 1010 1010 1010. The FCO and DCO outputs still work as usual while all channels shift out the test pattern. This pattern allows the user to perform timing alignment adjustments between the FCO, DCO, and the output data. For normal operation, this pin should be tied to AGND.

Table 9. Digital Test Pattern Pin Settings

Selected DTP	DTP Voltage	Resulting D+ and D–	Resulting FCO and DCO
Normal operation	AGND	Normal operation	Normal operation
DTP1	AVDD/3	1000 0000 0000	Normal operation
DTP2	2 \times AVDD/3	1010 1010 1010	Normal operation
Restricted	AVDD	N/A	N/A

Voltage Reference

A stable and accurate 0.5 V voltage reference is built into the AD9229. The input range can be adjusted by varying the reference voltage applied to the AD9229, using either the internal reference or an externally applied reference voltage. The input span of the ADC tracks reference voltage changes linearly.

When applying the decoupling capacitors to the VREF, REFT, and REFB pins, use ceramic, low ESR capacitors. These capacitors should be close to the ADC pins and on the same layer of the PCB as the AD9229. The recommended capacitor values and configurations for the AD9229 reference pin can be found in Figure 42 and Figure 43.

Table 10. Reference Settings

Selected Mode	SENSE Voltage	Resulting VREF (V)	Resulting Differential Span (V p-p)
External Reference	AVDD	N/A	2 \times external reference
Internal, 1 V p-p FSR Programmable	VREF 0.2 V to VREF	0.5 0.5 \times (1 + R2/R1)	1.0 2 \times VREF
Internal, 2 V p-p FSR	AGND to 0.2 V	1.0	2.0

Internal Reference Connection

A comparator within the AD9229 detects the potential at the SENSE pin and configures the reference into four possible states (summarized in Table 10). If SENSE is grounded, the reference amplifier switch is connected to the internal resistor divider (see Figure 42), setting VREF to 1 V. Connecting the SENSE pin to the VREF pin switches the amplifier output to the SENSE pin, configuring the internal op amp circuit as a voltage follower and providing a 0.5 V reference output. If an external resistor divider is connected as shown in Figure 43, the switch is again set to the SENSE pin. This puts the reference amplifier in a noninverting mode and defines the VREF output as

$$V_{REF} = 0.5 \times \left(1 + \frac{R2}{R1} \right)$$

In all reference configurations, REFT and REFB establish their input span of the ADC core. The analog input full-scale range of the ADC equals twice the voltage at the reference pin for either an internal or an external reference configuration.

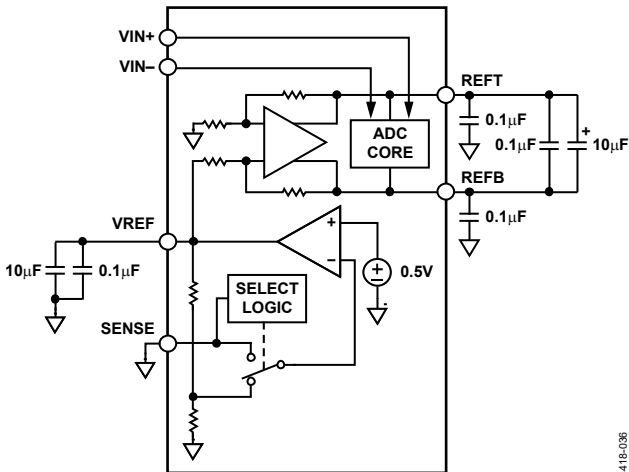

Figure 42. Internal Reference Configuration

04418-036

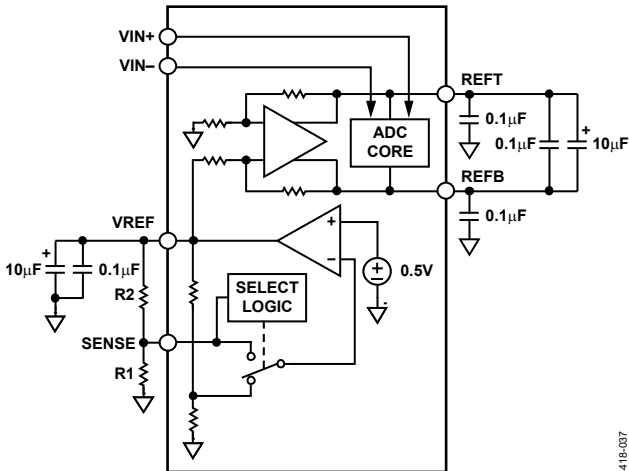

Figure 43. Programmable Reference Configuration

04418-037

If the internal reference of the AD9229 is used to drive multiple converters to improve gain matching, the loading of the reference by the other converters must be considered. Figure 44 depicts how the internal reference voltage is affected by loading.

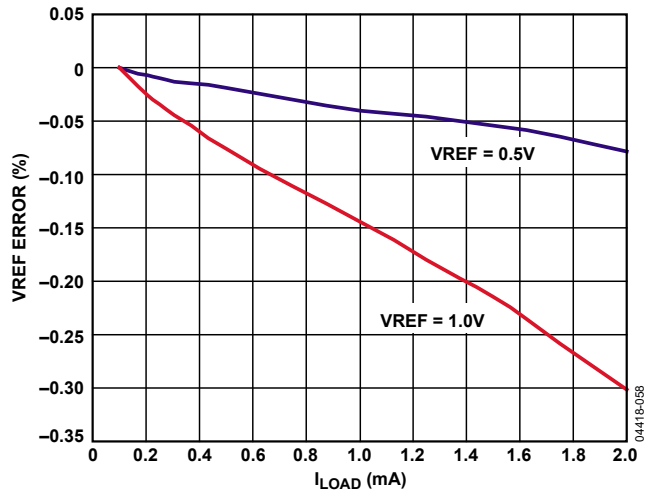

Figure 44. VREF Accuracy vs. Load

04418-038

External Reference Operation

The use of an external reference may be necessary to enhance the gain accuracy of the ADC or improve thermal drift characteristics. Figure 45 shows the typical drift characteristics of the internal reference.

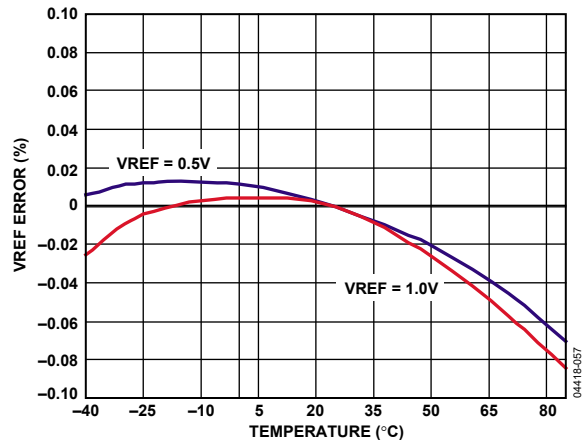

Figure 45. Typical VREF Drift

04418-037

When the SENSE pin is tied to AVDD, the internal reference is disabled, allowing the use of an external reference. The external reference is loaded with an equivalent 7 kΩ load. An internal reference buffer generates the positive and negative full-scale references, REFT and REFB, for the ADC core. Therefore, the external reference must be limited to a maximum of 1 V.

Power and Ground Recommendations

When connecting power to the AD9229, it is recommended that two separate 3.0 V supplies be used: one for analog (AVDD) and one for digital (DRVDD). If only one supply is available, it should be routed to the AVDD first and tapped off and isolated with a ferrite bead or filter choke with decoupling capacitors preceding. The user can employ several different decoupling capacitors to cover both high and low frequencies.

These should be located close to the point of entry at the PC board level and close to the parts with minimal trace length.

A single PC board ground plane should be sufficient when using the AD9229. With proper decoupling and smart partitioning of the PC board's analog, digital, and clock sections, optimum performance is easily achieved.

Exposed Paddle Thermal Heat Slug Recommendations

It is mandatory that the exposed paddle on the underside of the ADC be connected to analog ground (AGND) to achieve the best electrical and thermal performance of the AD9229. A continuous exposed copper plane on the PCB should mate to the AD9229 exposed paddle, Pin 0. The copper plane should have several vias to achieve the lowest possible resistive thermal path for heat dissipation to flow through the bottom of the PCB. These vias should be solder or epoxy filled (plugged).

To maximize the solder coverage and adhesion between the ADC and PCB, overlay a silkscreen to partition the continuous copper plane on the PCB into several uniform sections. This provides several tie points between the two during the reflow process. Using one continuous plane with no silkscreen partitions only guarantees one tie point between the ADC and PCB. See Figure 46 for a PCB layout example. For detailed information on packaging and the PCB layout of chip scale packages, visit www.analog.com.

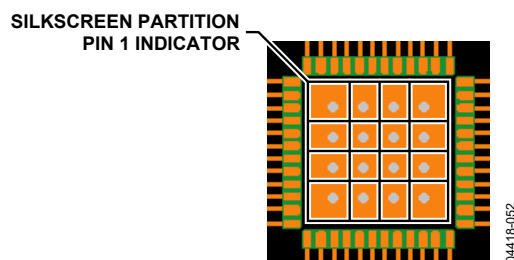

Figure 46. Typical PCB Layout

EVALUATION BOARD

The AD9229 evaluation board provides all of the support circuitry required to operate the ADC in its various modes and configurations. The converter can be driven differentially through a transformer (default) or through the AD8332 driver. The ADC can also be driven in a single-ended fashion. Separate power pins are provided to isolate the DUT from the AD8332 drive circuitry. Each input configuration can be selected by proper connection of various jumpers (see Figure 48 to Figure 52). Figure 47 shows the typical bench characterization setup used to evaluate the ac performance of the AD9229. It is critical that the signal sources used for the analog input and clock have very low phase noise (<1 ps rms jitter) to realize the ultimate performance of the converter. Proper filtering of the analog input signal to remove harmonics and lower the integrated or broadband noise at the input is also necessary to achieve the specified noise performance.

See Figure 47 to Figure 57 for complete schematics and layout plots that demonstrate the routing and grounding techniques that should be applied at the system level.

POWER SUPPLIES

This evaluation board comes with a wall mountable switching power supply that provides a 6 V, 2 A maximum output. Simply connect the supply to the rated 100 V to 240 V ac wall outlet at 47 Hz to 63 Hz. The other end is a 2.1 mm inner diameter jack that connects to the PCB at P503. Once on the PC board, the 6 V supply is fused and conditioned before connecting to three low dropout linear regulators that supply the proper bias to each of the various sections on the board.

When operating the evaluation board in a nondefault condition, L504 to L506 can be removed to disconnect the

switching power supply. This enables the user to individually bias each section of the board. Use P501 to connect a different supply for each section. At least one 3.0 V supply is needed with a 1 A current capability for AVDD_DUT and DRVDD_DUT; however, it is recommended that separate supplies be used for both analog and digital. To operate the evaluation board using the VGA option, a separate 5.0 V analog supply is needed in addition to the other 3.0 V supplies. The 5.0 V supply, or AVDD_VGA, should have a 1 A current capability as well.

INPUT SIGNALS

When connecting the clock and analog source, use clean signal generators with low phase noise, such as Rohde & Schwarz SMHU or HP8644 signal generators or the equivalent. Use 1 m long, shielded, RG-58, 50 Ω coaxial cable for making connections to the evaluation board. Dial in the desired frequency and amplitude within the ADC's specifications tables. Typically, most ADI evaluation boards can accept a ~2.8 V p-p or 13 dBm sine wave input for the clock. When connecting the analog input source, it is recommended to use a multipole, narrow-band band-pass filter with 50 Ω terminations. ADI uses TTE, Allen Avionics, and K&L types of band-pass filters. The filter should be connected directly to the evaluation board if possible.

OUTPUT SIGNALS

The default setup uses the HSC-ADC-FPGA high speed deserialization board, which deserializes the digital output data and converts it to parallel CMOS. These two channels interface directly with ADI's standard dual-channel FIFO data capture board (HSC-ADC-EVALA-DC). Two of the four channels can then be evaluated at the same time. For more information on channel settings on these boards and their optional settings, visit www.analog.com/FIFO.

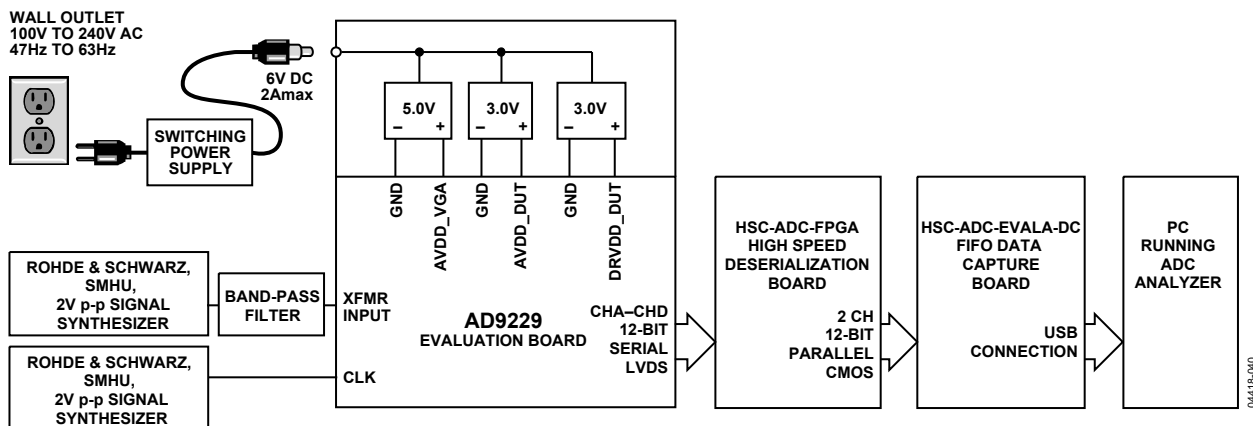

Figure 47. Evaluation Board Connections

DEFAULT OPERATION AND JUMPER SELECTION SETTINGS

The following is a list of the default and optional settings or modes allowed on the AD9229 Rev C evaluation board.

- **POWER:** Connect the switching power supply that is supplied in the evaluation kit between a rated 100 V to 240 V ac wall outlet at 47 Hz to 63 Hz and P503.
- **AIN:** The evaluation board is set up for a transformer coupled analog input with optimum 50 Ω impedance matching out to 400 MHz. For more bandwidth response, the 2.2 pF differential capacitor across the analog inputs could be changed or removed. The common mode of the analog inputs is developed from the center tap of the transformer or AVDD_DUT/2.
- **VREF:** VREF is set to 1.0 V by tying the SENSE pin to ground, R224. This causes the ADC to operate in 2.0 V p-p full-scale range. A number of other VREF options are available on the evaluation board, including 1.0 V p-p full-scale range, a variable range that the user can set by choosing R219 and R220 as well as a separate external reference option using the ADR510 or ADR520. Simply populate R218 and R222 and remove C208. To use these optional VREF modes, switch the jumper setting on R221 to R224. Proper use of the VREF options is noted in the Voltage Reference section.
- **CLOCK:** The clock input circuitry is derived from a simple logic circuit using a high speed inverter that adds a very low amount of jitter to the clock path. The clock input is 50 Ω terminated and ac-coupled to handle sine wave type inputs. If using an oscillator, two oscillator footprint options are also available (OSC200-201) to check the ADC's performance. J203 and J204 give the user flexibility in using the enable pin, which is common on most oscillators.
- **PWDN:** To enable the power-down feature, simply short JP201 to AVDD on the PWDN pin.
- **DTP:** To enable one of the two digital test patterns on digital outputs of the ADC, use JP202. If Pins 2 and 3 on JP202 are tied together (1.0 V source), this enables test pattern 1000 0000 0000. If Pins 1 and 2 on JP202 are tied together (2.0 V source), this enables test pattern 1010 1010 1010. See the DTP Pin section for more details.
- **LVDSBIAS:** To change the level of the LVDS output level swing, simply change the value of R204. Other recommended values can be found in the Digital Outputs section.
- **D+, D-:** If an alternate data capture method to the setup described in Figure 47 is used, optional receiver terminations, R205 to R210, can be installed next to the high speed backplane connector.

ALTERNATE ANALOG INPUT DRIVE CONFIGURATION

The following is a brief description of the alternate analog input drive configuration using the AD8332 dual VGA. This particular drive option may need to be populated, in which case all the necessary components are listed in Table 11. This table lists the necessary settings to properly configure the evaluation board for this option. For more details on the AD8332 dual VGA, how it works, and its optional pin settings, consult the AD8332 data sheet.

To configure the analog input to drive the VGA instead of the default transformer option, the following components need to be removed and/or changed.

1. Remove R102, R115, R128, R141, T101, T102, T103, and T1044 in the default analog input path.
2. Populate R101, R114, R127, and R140 with 0 Ω resistors in the analog input path.
3. Populate R106, R107, R119, R120, R132, R133, R144, and R145 with 10 k Ω resistors to provide an input common-mode level to the analog input.
4. Populate R105, R113, R118, R124, R131, R137, R151, and R43 with 0 Ω resistors in the analog input path.
5. Currently L305 to L312 and L405 to L412 are populated with 0 Ω resistors to allow signal connection. This area allows the user to design a filter if additional requirements are necessary.

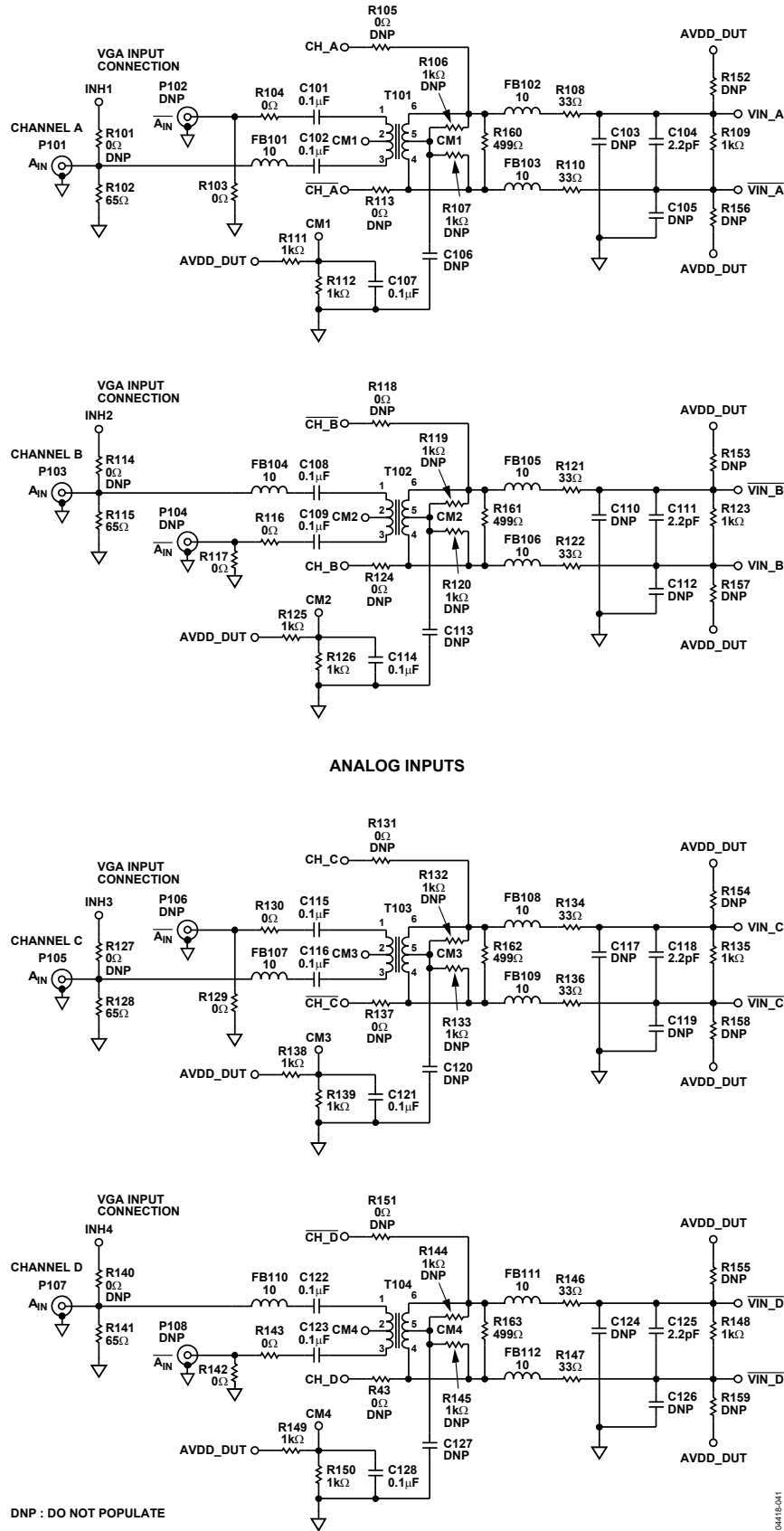
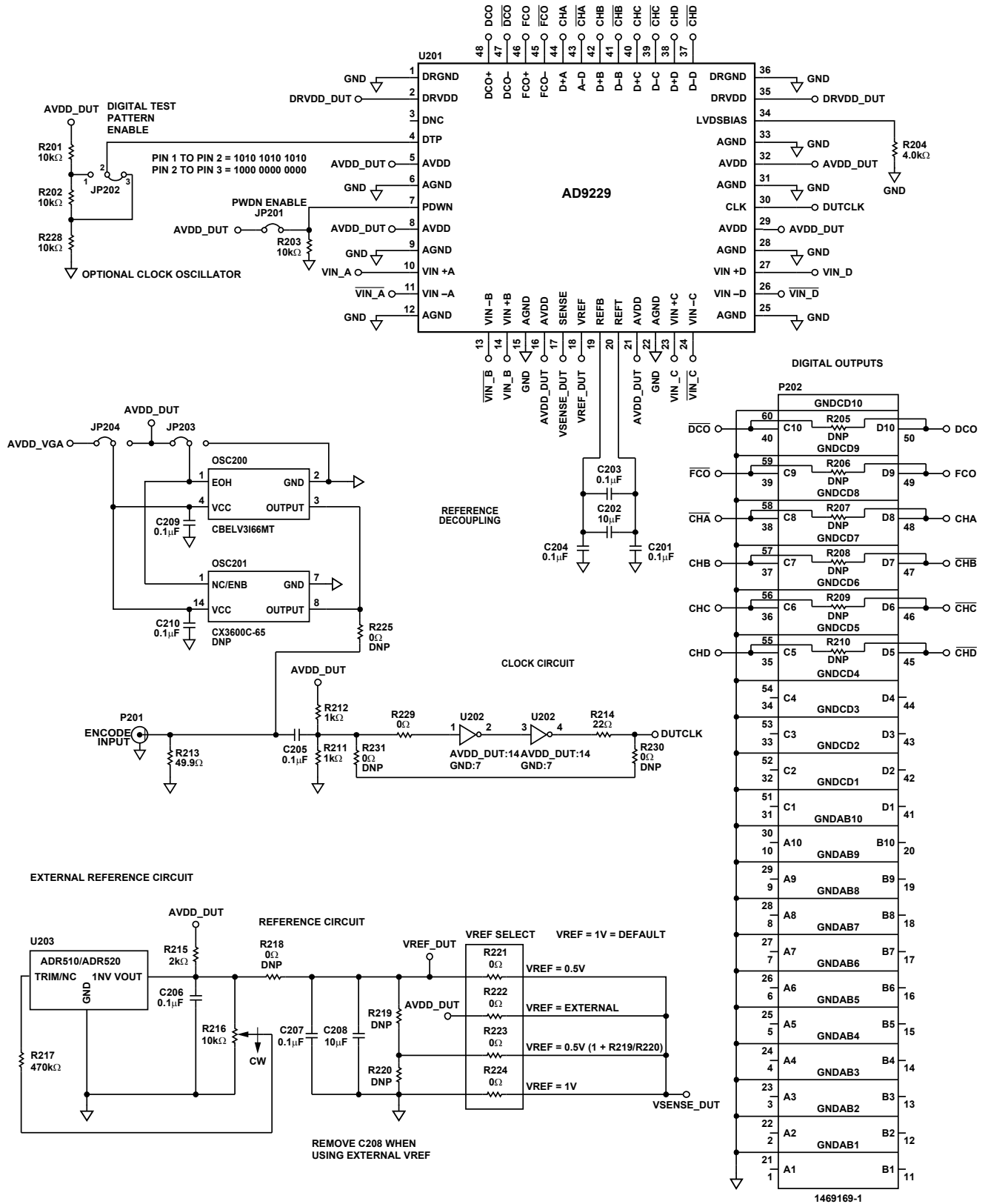

Figure 48. Evaluation Board Schematic, DUT Analog Inputs



DNP : DO NOT POPULATE

R205-R210
OPTIONAL OUTPUT
TERMINATIONS

04115-02

Figure 49. Evaluation Board Schematic, DUT, VREF, Clock Inputs, and Digital Output Interface

OPTIONAL VGA DRIVE CIRCUIT FOR CHANNELS C AND D

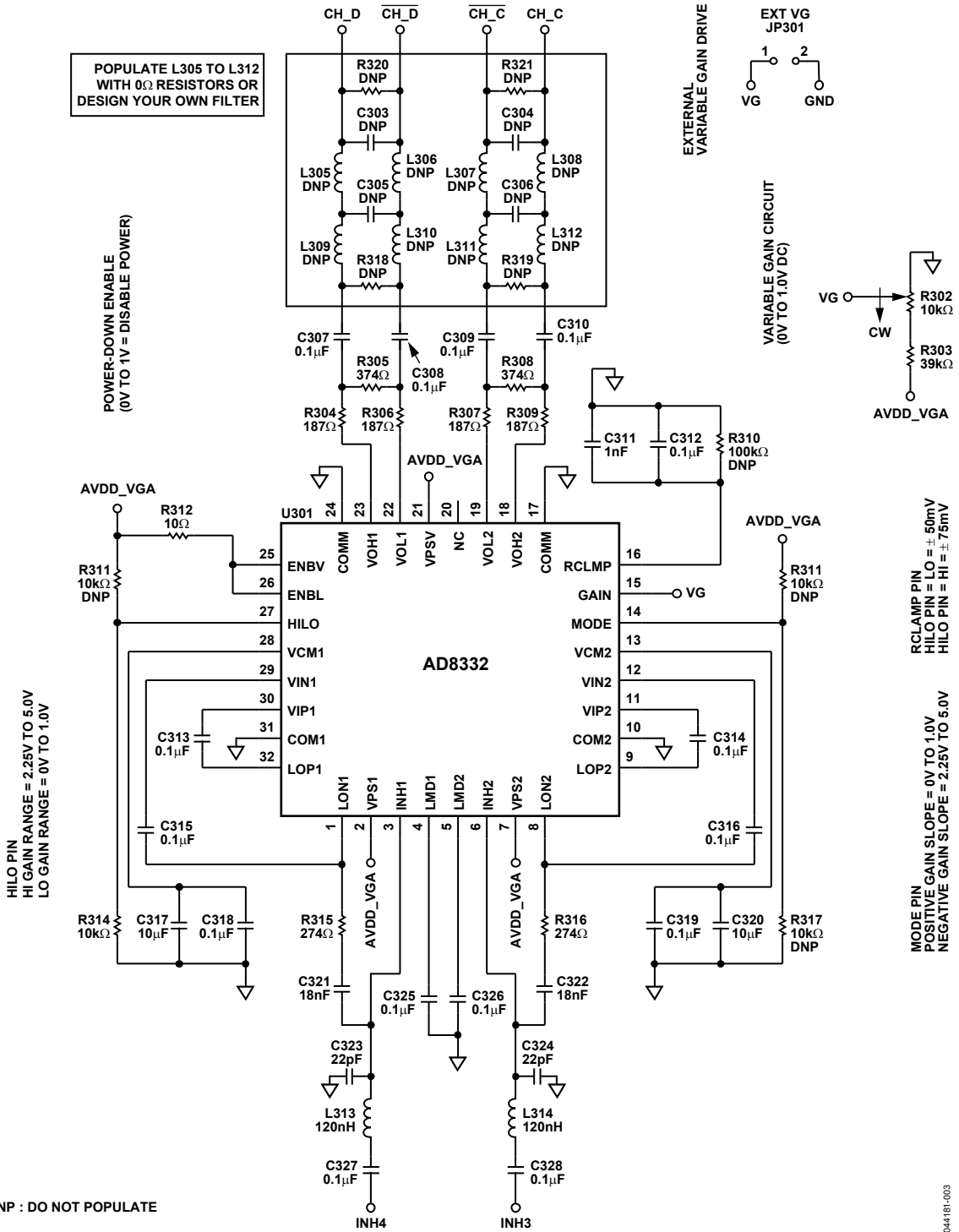

Figure 50. Evaluation Board Schematic, Optional DUT Analog Input Drive

OPTIONAL VGA DRIVE CIRCUIT FOR CHANNELS A AND B

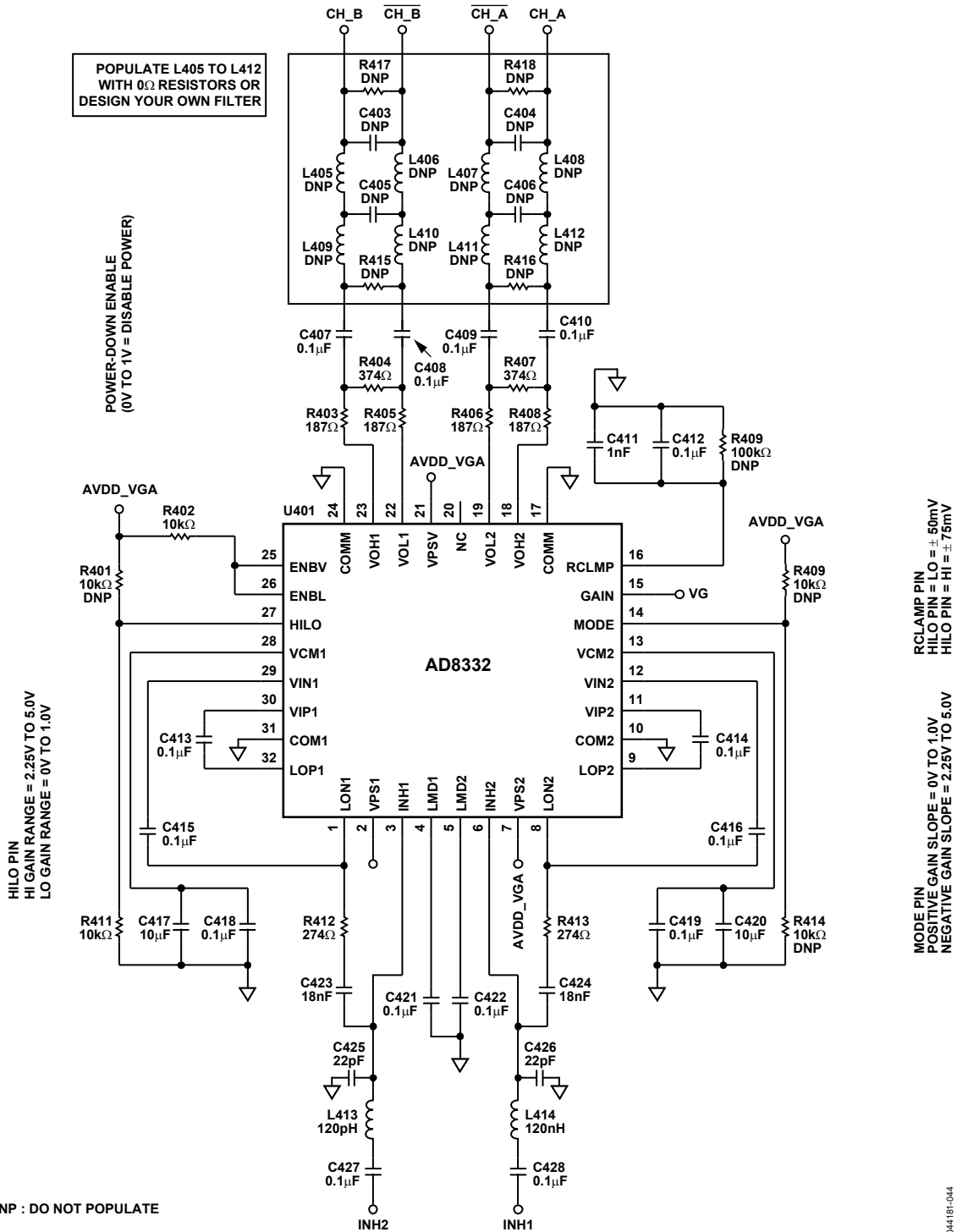
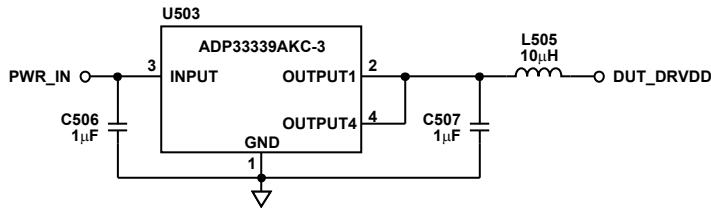
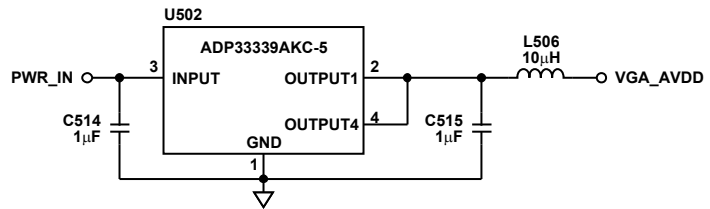
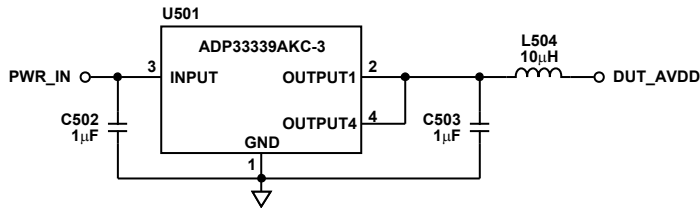
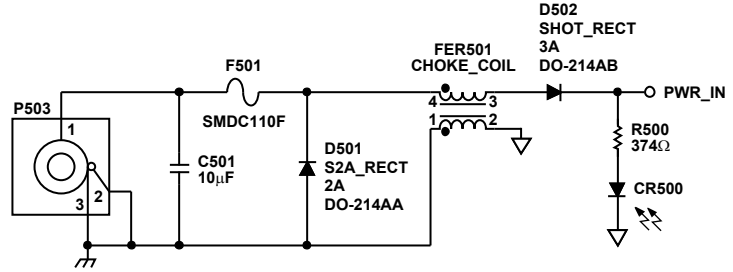

Figure 51. Evaluation Board Schematic, Optional DUT Analog Input Drive Continued

AD9229

POWER SUPPLY INPUT
6V
2A MAX



OPTIONAL POWER INPUT

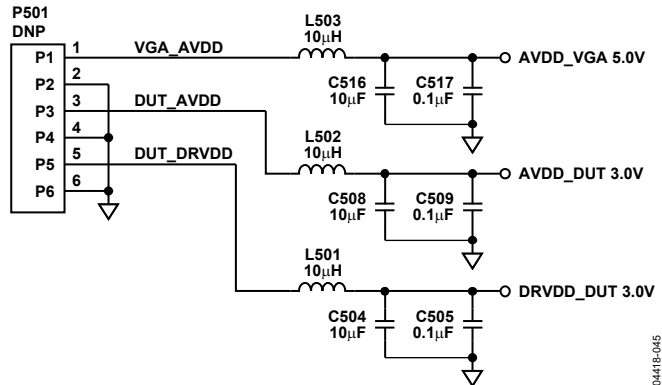

DNP : DO NOT POPULATE

Figure 52. Evaluation Board Schematic, Power Supply Inputs

04418-045

DECOUPLING CAPACITORS

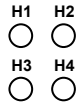
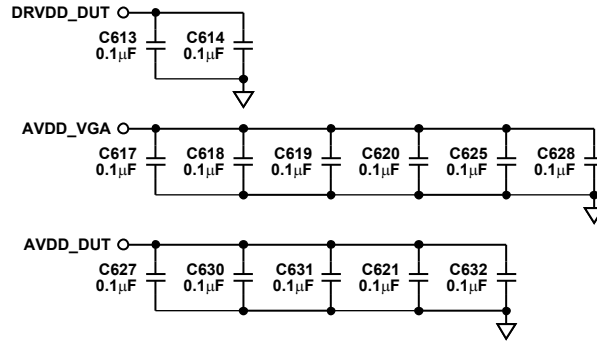

MOUNTING HOLES
CONNECTED TO GROUND

UNUSED GATES

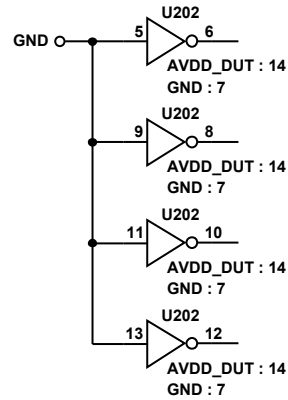

DNP : DO NOT POPULATE

04418-046

Figure 53. Evaluation Board Schematic, Decoupling and Miscellaneous

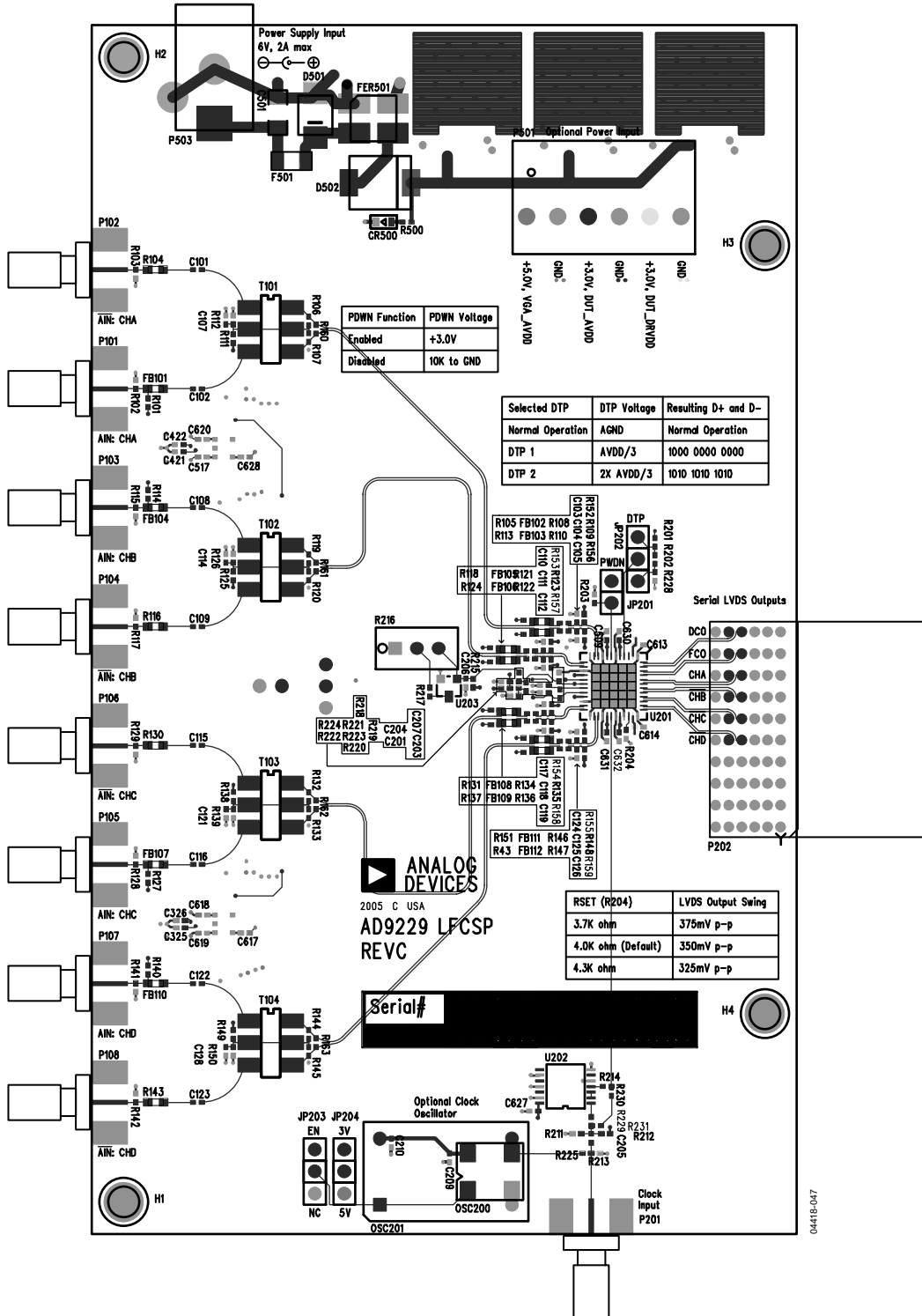
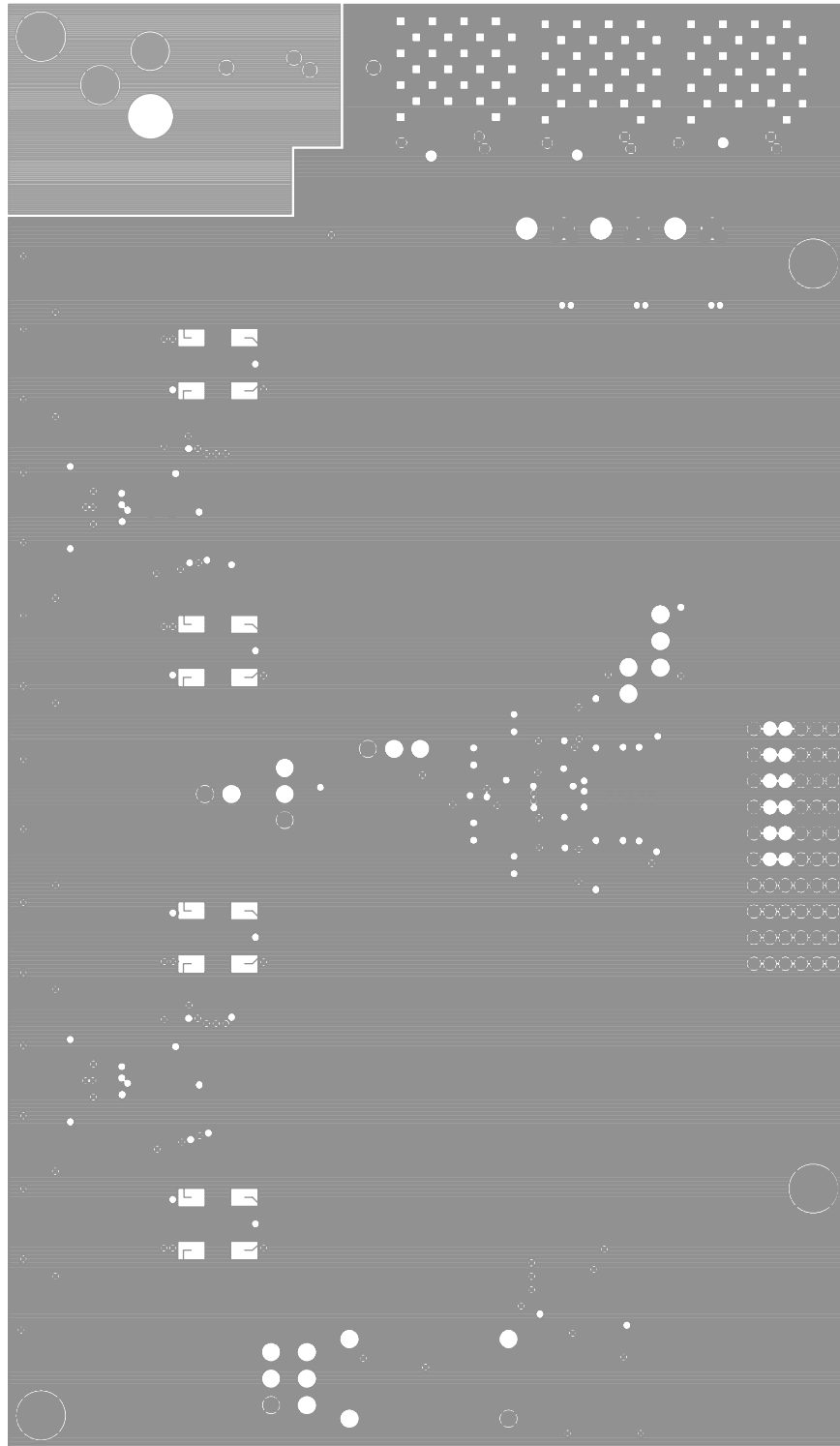

Figure 54. Evaluation Board Layout, Primary Side



04418-048

Figure 55. Evaluation Board Layout, Ground Plane

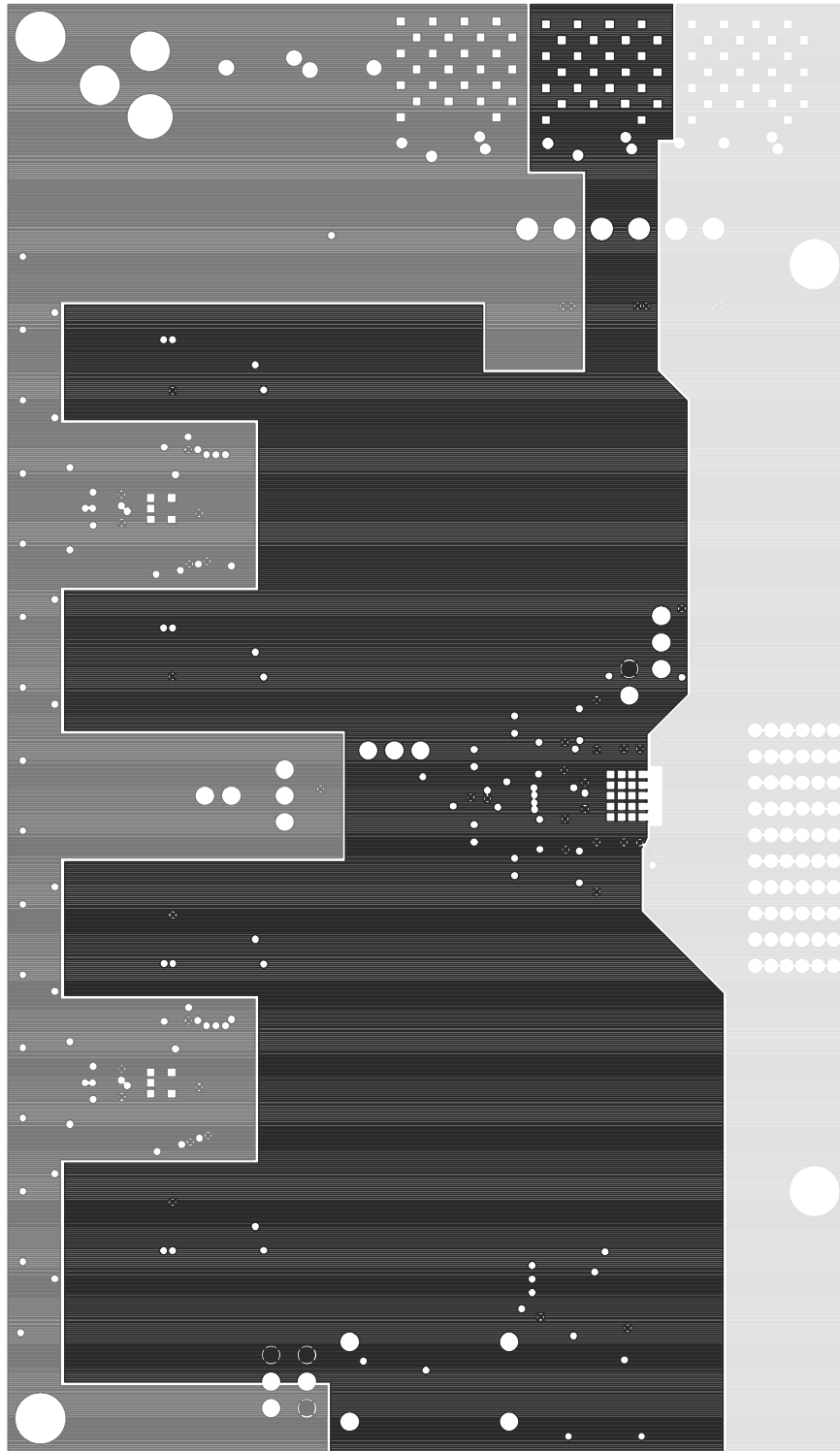

Figure 56. Evaluation Board Layout, Power Plane

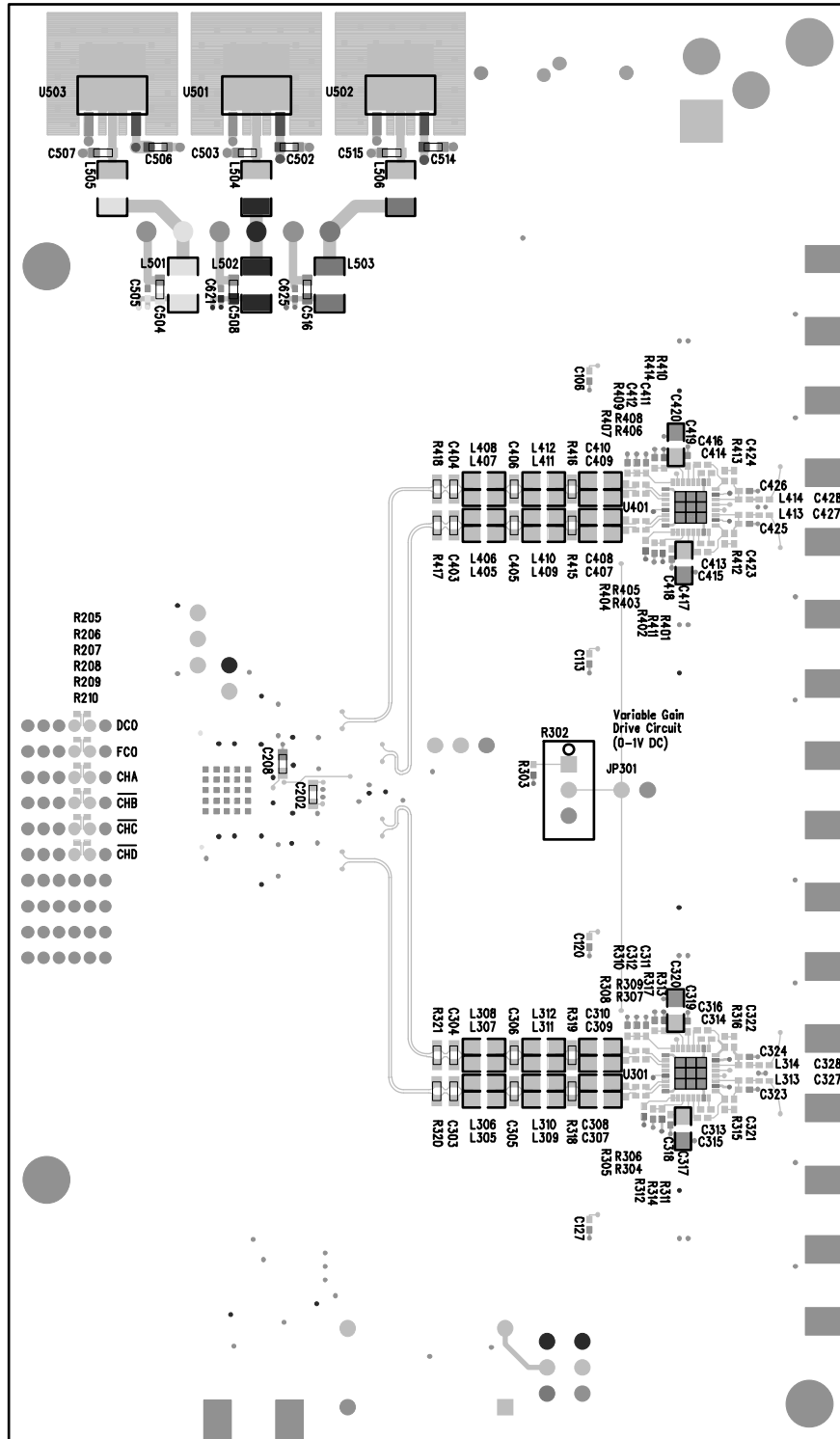

Figure 57. Evaluation Board Layout, Secondary Side (Mirrored Image)

04418-050

AD9229

Table 11. Evaluation Board Bill of Materials (BOM)

Item	Qty. per Board	REFDES	Device	Pkg.	Value	Mfg.	Mfg. Part Number
1	1	AD9229LFCSP_REVC	PCB	PCB	PCB		
2	59	C327, C328, C630, C628, C629, C631, C632, C101, C102, C107, C108, C109, C114, C115, C116, C121, C122, C123, C128, C201, C203, C204, C205, C206, C207, C313, C314, C315, C312, C318, C319, C412, C316, C325, C326, C413, C414, C415, C418, C419, C416, C421, C422, C427, C428, C505, C509, C517, C613, C614, C617, C618, C619, C620, C621, C625, C209, C210, C627	Capacitor	402	0.1 μ F, ceramic, X5R, 10 V, 10% tol	Panasonic	ECJ-0EB1A104K
3	4	C104, C111, C118, C125	Capacitor	402	2.2 pF, ceramic, COG, 0.25 pF tol, 50 V	Murata	GRM1555C1H2R2GZ01B
4	9	C202, C208, C317, C320, C417, C420, C504, C508, C516	Capacitor	805	10 μ F, 6.3 V \pm 10% ceramic X5R	AVX	08056D106KAT2A
5	8	C307, C308, C309, C310, C407, C408, C409, C410	Capacitor	603	0.1 μ F, ceramic, X7R, 16 V, 10% tol	Kemet	C0603C104K4RACTU
6	2	C311, C411	Capacitor	402	1000 pF, ceramic, X7R, 25 V, 10% tol	Kemet	C0402C102K3RACTU
7	4	C321, C322, C423, C424	Capacitor	402	0.018 μ F, ceramic, X7R, 16 V, 10% tol	AVX	0402YC183KAT2A
8	4	C323, C324, C425, C426	Capacitor	402	22 pF, ceramic, NPO, 5% tol, 50 V	Kemet	C0402C220J5GACTU
9	1	C501	Capacitor	1206	10 μ F, tantalum, 16 V, 10% tol	Kemet	T491B106K016AS
10	6	C502, C503, C506, C507, C514, C515	Capacitor	603	1 μ F, ceramic, X5R, 6.3 V, 10% tol	Panasonic	ECJ-1VB0J105K
11	1	CR500	LED	603	Green, 4 V, 5 m candela	Panasonic	LNJ314G8TRA
12	1	D502	Diode	DO-214AB	3 A, 30 V, SMC	Micro Commercial Co.	SK33MSCT
13	1	D501	Diode	DO-214AA	2 A, 50 V, SMC	Micro Commercial Co.	S2A
14	1	F501	Fuse	1210	6.0 V, 2.2 A trip current resettable fuse	Tyco/Raychem	NANOSMDC110F-2
15	1	FER501	Ferrite bead	2020	10 μ H, 5 A, 50 V, 190 Ω @ 100 MHz	Murata	DLW5BSN191SQ2L
16	12	FB101, FB102, FB103, FB104, FB105, FB106, FB107, FB108, FB109, FB110, FB111, FB112	Ferrite bead	603	10 Ω , test freq 100 MHz, 25% tol, 500 mA	Murata	BLM18BA100SN1
17	2	JP201, JP301	Connector	2-pin	100 mil header jumper, 2-pin	Samtec	TSW-102-07-G-S
18	3	JP204, JP203, JP202	Connector	3-pin	100 mil header jumper, 3-pin	Samtec	TSW-103-07-G-S

Item	Qty. per Board	REFDES	Device	Pkg.	Value	Mfg.	Mfg. Part Number
19	6	L501, L502, L503, L504, L505, L506	Ferrite bead	1210	10 μ H, bead core 3.2 \times 2.5 \times 1.6 SMD, 2 A	Panasonic - ECG	EXC-CL3225U1
20	4	L313, L314, L413, L414	Inductor	402	120 nH, test freq 100 MHz, 5% tol, 150 mA	Murata	LQG15HNR12J02B
21	12	L305, L306, L307, L308, L309, L310, L405, L406, L407, L408, L409, L410, L311, L312, L411, L412	Resistor	805	0 Ω , 1/8 W, 5% tol	Panasonic	ERJ-6GEY0R00V
22	1	OSC200	Oscillator	SMT	Clock oscillator, 66.66 MHz, 3.3 V	CTS REEVES	CB3LV-3C-66M6666-T
23	5	P201, P101, P103, P105, P107	Connector	SMA	Sidemount SMA for 0.063" board thickness	Johnson Components	142-0711-821
24	1	P202	Connector	HEADER	1469169-1, right angle 2-pair, 25 mm, header assembly	Tyco	1469169-1
25	1	P503	Connector	0.1", PCMT	RAPC722, power supply connector	Switchcraft	SC1153
26	10	R201, R202, R228, R203, R312, R314, R317, R402, R411, R414	Resistor	402	10 k Ω , 1/16 W, 5% tol	Yageo America	9C04021A1002JLHF3
27	7	R225, R129, R142, R224	Resistor	402	0 Ω , 1/16 W, 5% tol	Yageo America	9C04021A0R00JLHF3
28	4	R102, R115, R128, R141	Resistor	402	64.9 Ω , 1/16 W, 1% tol	Panasonic	ERJ-2RKF64R9X
29	4	R104, R116, R130, R143	Resistor	603	0 Ω , 1/10 W, 5% tol	Panasonic	ERJ-3GEY0R00V
30	14	R111, R112, R125, R126, R138, R139, R149, R150, R211, R212, R109, R123, R135, R148	Resistor	402	1 k Ω , 1/16 W, 1% tol	Panasonic	ERJ-2RKF1001X
31	8	R108, R110, R121, R122, R134, R136, R146, R147	Resistor	402	33 Ω , 1/16 W, 5% tol	Yageo America	9C04021A33R0JLHF3
32	4	R160, R161, R162, R163	Resistor	402	499 Ω , 1/16 W, 1% tol	Panasonic	ERJ-2RKF4990X
33	1	R215	Resistor	402	2 k Ω , 1/16 W, 5% tol	Yageo America	9C04021A2001JLHF3
34	1	R204	Resistor	402	4.02 k Ω , 1/16 W, 1% tol	Panasonic	ERJ-2RKF4021X
35	1	R213	Resistor	402	49.9 Ω , 1/16 W, 0.5% tol	Susumu	RR0510R-49R9-D
36	1	R214	Resistor	402	22 Ω , 1/16 W, 5% tol	Yageo America	9C04021A22R0JLHF3
37	2	R216, R302	Potentiometer	3-lead	10 k Ω , Cermet trimmer potentiometer, 18 turn top adjust, 10%, 1/2 W	BC Components	CT-94W-103
38	1	R217	Resistor	402	470 k Ω , 1/16 W, 5% tol	Yageo America	9C04021A4703JLHF3
39	1	R303	Resistor	402	39 k Ω , 1/16 W, 5% tol	Susumu	RR0510P-393-D
40	8	R304, R306, R307, R309, R403, R405, R406, R408,	Resistor	402	187 Ω , 1/16 W, 1% tol	Panasonic	ERJ-2RKF1870X

AD9229

Item	Qty. per Board	REFDES	Device	Pkg.	Value	Mfg.	Mfg. Part Number
41	4	R305, R308, R404, R407, R500	Resistor	402	374 Ω, 1/16 W, 1% tol	Panasonic	ERJ-2RKF3740X
42	4	R315, R316, R412, R413	Resistor	402	274 Ω, 1/16 W, 1% tol	Panasonic	ERJ-2RKF2740X
43	4	T101, T102, T103, T104	Transformer	CD542	ADT1-1WT, 1:1 impedance ratio transformer	Mini-Circuits	ADT1-1WT
44	2	U501, U503	IC	SOT-223	ADP33339AKC-3, 1.5 A, 3.0 V LDO regulator	ADI	ADP33339AKC-3
45	2	U301, U401	IC	LFCSP, CP-32	AD8332ACP, ultralow noise precision dual VGA	ADI	AD8332ACP
46	1	U502	IC	SOT-223	ADP33339AKC-5	ADI	ADP33339AKC-5
47	1	U201	IC	LFCSP, CP-48-1	AD9229-65, quad 12-bit, 65 MSPS serial LVDS 3 V ADC	ADI	AD9229ABCPZ-65
48	1	U203	IC	SOT-23	ADR510AR, 1.0 V, precision low noise shunt voltage reference	ADI	ADR510AR
49	1	U202	IC	TSSOP	74VHC04MTC, hex inverter	Fairchild	74VHC04MTC
50	4	MP101-104	Part of assembly		CBSB-14-01A-RT, 7/8" height, standoffs for circuit board support	Richco	CBSB-14-01A-RT
51	4	MP105-108	Part of assembly		SNT-100-BK-G-H, 100 mil jumpers	Samtec	SNT-100-BK-G-H
52	4	MP109-112	Part of assembly		5-330808-3, pin sockets, closed end for OSC200	AMP	5-330808-3

AD9229

NOTES

Looking for pricing, stock, or lifecycle information?

Click below to explore more details on WIN SOURCE:

 [View AD9229BCPZ-65 on WIN SOURCE](#)

 [Analog Devices Inc. Information](#)

Optimize Your Supply Chain with WIN SOURCE Solutions

-  Global Sourcing Solution
-  Obsolete Management
-  Cost Control Management
-  Shortage Management
-  Alternative Solution
-  Excess Inventory Management