



**THE DATASHEET OF
EM8500-A001-LF24B+**





POWER MANAGEMENT CONTROLLER WITH ENERGY HARVESTING INTERFACE

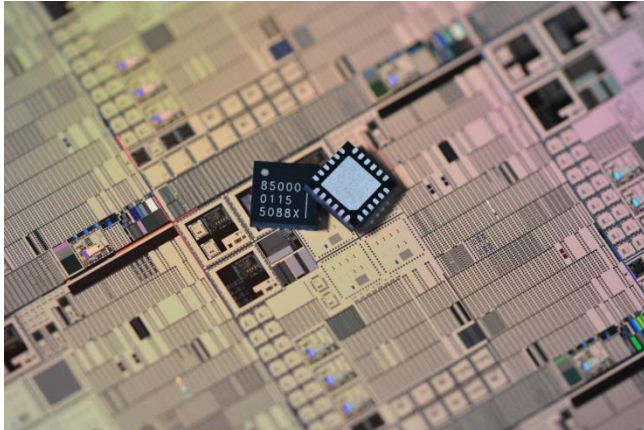

Description

The EM8500 is an integrated power management solution for low power applications. It is specifically designed for efficient operation with a variety of DC harvesting sources including thermal electric generators (TEG) or photovoltaic (solar) sources in the μW to mW range.

The device is designed to speed-up system start-up time when the main energy storage element (aka Long Term Storage – LTS) is completely discharged or insufficiently charged to supply the application, by using a secondary energy storage element (Short Term Storage - STS).

When using a non-rechargeable primary battery the EM8500's on-board PMU offers a mechanism to extend battery life when assisted by a harvesting element.

The EM8500 incorporates a boost converter able to start with an input voltage as low as 300 mV and an input power of few μW .

In functional mode the EM8500 operates at energy levels from a DC harvesting source as low as 100 mV and 1 μW . To maximize harvesting efficiency the EM8500 integrates a programmable maximum power point tracking controller.

The EM8500 is capable of working with a variety of energy elements as secondary storage, namely re-chargeable batteries, super-capacitors or conventional capacitors. In all cases the EM8500 maintains its fast start-up capability that depends only on the harvester conditions and the STS capacitor value.

A USB connection to an external power source is available on the EM8500 for fast charge of the long term storage element.

The EM8500 integrates voltage supervisory functions. Minimum and maximum voltages are controlled on the LTS element to prevent damage to the energy storage element. Harvester minimum voltage monitoring allows stopping the DCDC limiting power loss when no energy can be harvested. Output voltages are kept in a safe range for the application.

To perform granular power management of the application, the EM8500 integrates four independent supply outputs and a sleep mode offering the capability to switch off part or all the supplies.

The EM8500 is available in an industry standard QFN24 4x4 package or as a solder bump flip-chip device.

Features

- Flexible operation with different energy banks
 - Primary cell battery
 - Secondary cell battery
 - Capacitors (gold-cap, super-cap)
- Ultra-low power DCDC boost converter with very high efficiency
 - Operating mode minimum voltage $V_{DD_HRV} \geq 100 \text{ mV}$ (typical)
 - Operating mode minimum power: $P_{IN} \geq 1 \mu\text{W}$ (typical)
 - Quiescent current: $I_Q \leq 125 \text{ nA}$
 - Cold-start minimum voltage: $V_{IN} \geq 300 \text{ mV}$
 - Cold-start minimum power: $P_{IN} \geq 3 \mu\text{W}$ (typical)
- Fast start-up on any energy storage
 - Dual energy storage elements
- Power management control
 - Multiple independent supply outputs
 - Sleep mode and wake-up functions
 - User programmable under-voltage and over-voltage levels
- Limited external components
 - Device configurations are stored in on-chip $E^2\text{PROM}$
 - Dynamic configuration through a SPI or $I^2\text{C}$ interface
- Extended power management status
 - Battery on protection mode
 - LTS/STS connection status
 - Minimum/Maximum voltage warning
 - USB connected

Applications

- Energy harvesting equipped platforms
 - Solar charging
 - Thermo-electrical generator harvesting (TEG)
- Wearable systems
- Beacons and wireless sensor networks
- Industrial and environmental monitoring
- Battery operated platforms

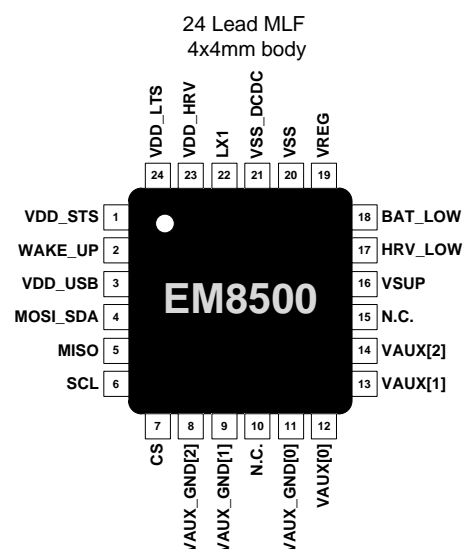

Figure 1-1 QFN24 Package



TABLE OF CONTENTS

- 1. Product description 4**
 - 1.1. Operating modes.....4
 - 1.2. voltage naming conventions4
 - 1.3. Block diagram5
 - 1.4. Functional description6
 - 1.4.1. Cold-start on harvester6
 - 1.4.2. Start-up on Long Term Storage (LTS)7
 - 1.4.3. System shut-down8
- 2. Handling Procedures 9**
- 3. Pin description 9**
- 4. Electrical specifications 10**
 - 4.1. Absolute Maximum Ratings 10
 - 4.2. Operating Conditions..... 10
 - 4.3. Electrical Characteristics 10
 - 4.4. Timing diagrams 12
 - 4.4.1. SPI interface 12
 - 4.4.2. I2C Interface 12
- 5. Product configuration 12**
 - 5.1. Status information 12
 - 5.2. Supervising and harvester controller behaviour 13
 - 5.2.1. Storage element 13
 - 5.2.2. Harvester power supervisory functions 14
 - 5.2.3. Timing configuration 15
 - 5.2.4. Maximum Power Point tracking..... 16
 - 5.3. Power management functions 16
 - 5.4. Primary cell configuration 18
 - 5.5. Sleep mode and Wake-up functions 19
 - 5.6. Lux-meter 19
 - 5.7. USB charging 21
 - 5.8. Miscellaneous functions 21
 - 5.8.1. Soft reset function 21
 - 5.8.2. Register protection 22
 - 5.8.3. LTS protection DISABLE 22
 - 5.8.4. DCDC off forcing 22
- 6. Serial interface 22**
 - 6.1. I2C interface..... 22
 - 6.2. SPI interface..... 23
 - 6.2.1. Interface selection 24
 - 6.3. E2PROM..... 24
 - 6.3.1. Accessing the E2PROM 24



7. Typical characteristics	27
8. Register map.....	28
9. Typical Applications	31
9.1. SAMPLE schematics	31
9.1.1. Solar cell assisted system	31
9.1.2. termo-electrical generator (TEG) assisted system	32
9.2. Inductor selection.....	32
9.2.1. Reference Inductors	32
9.3. Capacitor selection	33
10. Ordering Information.....	33
11. Package Information	33
11.1. QFN24 4x4 package	33
11.1.1. Package marking	33

1. PRODUCT DESCRIPTION

The EM8500 is a power management IC with battery charger functions. It manages different energy source elements: a harvester through VDD_HRV, external supply through VDD_USB, a battery or a Long Term Storage (LTS) through VDD_LTS. It generates a local supply on a Short Term Storage (STS), visible through VDD_STS. The EM8500 provides the supply to the application from the energy sources. Surplus energy is stored in a LTS element.

Features and benefits include:

- **Power management controller, extending application battery life:** the EM8500 supplies the external application through the pins VSUP and VAUX[i]. The voltage is delivered directly from VDD_STS or through a regulator. On the VSUP pin a wake-up function allows to automatically re-enable the supply after a given time. For external devices using an I²C serial interface, it is possible to disconnect their ground through the use of the auxiliary ground pins (VAUX_GND). This solution avoids supplying the devices connected to a switched-off output supply through the pull-up of I²C bus. Overall power consumption is reduced by turning off peripheral ICs through the EM8500.
- **Battery charger from harvester source:** EM8500 manages energy harvesting from a low voltage and low power DC source such as single/dual junction solar cells or thermal electrical generator (TEG). The device embeds hardware MPPT (Maximum Power Point Tracking) algorithm to extract maximum energy from the harvester element. The DCDC boost converter is able to start the application from the harvester source. With its dual storage architecture, application start-up is fast and independent of the battery voltage.
- **Battery charger from USB source :** Fast charging is supported through a USB compatible supply input on the EM8500 (system start-up and battery charging to maximum voltage with configurable speed).
- **Voltage and current supervisor:** The EM8500 includes supervisory functions to detect harvester energy levels detecting (visible through the HRV_LOW pin) – and to monitor low battery voltage levels (visible through the BAT_LOW pin). The EM8500 protects the battery against over voltage conditions and automatically stops charging when a configurable threshold level is reached.
- **Configuration with E²PROM, no additional external components:** The mode and functional configuration of the EM8500 is controlled by the host MCU through a SPI or an I²C interface. Voltage supervision thresholds are set by registers. Configuration parameters are held in on-chip non-volatile memory (E²PROM). The EM8500 default configuration parameter values can be modified by the user.

1.1. OPERATING MODES

The EM8500 operates in three main modes:

- 1) Normal mode (STS and LTS Connected)
 - V_{LTS} is inside battery operating range.
 - LTS is connected to STS.
 - The system can be configured to disconnect VAUX or/and VAUX_GND pins.
- 2) LTS protection mode (STS and LTS disconnected)
 - EM8500 enters this mode when V_{LTS} drops below minimum battery operation (v_bat_min_lo).
 - BAT_LOW pin is set to '1'.
 - LTS and STS are disconnected to protect LTS against under voltage condition.
 - VSUP and VAUX are maintained through the DCDC converter only.
- 3) Sleep mode
 - VSUP is not supplied – no communication on SPI/I²C interface.
 - VSUP can be re-activated by WAKE_UP pin or internal timer.

1.2. VOLTAGE NAMING CONVENTIONS

To describe the operation of this product, the following set of voltage naming conventions is adopted throughout this document , Table 1-1:

NAME	DESCRIPTION
v_bat_max_hi	Maximum battery voltage. High level of hysteresis.
v_bat_min_hi_dis	Minimum STS maintenance voltage – acts as v_bat_min_hi when STS and LTS are disconnected
v_bat_min_hi_con	Minimum battery maintenance voltage – acts as v_bat_min_hi when STS and LTS are connected
v_bat_min_hi	Minimum battery voltage. High level of hysteresis Equal to v_bat_min_hi_dis or v_bat_min_hi_con according to the connection state in between STS and LTS. The term "v_bat_min_hi" is used here whenever there is no specific usage of the connected and disconnected values
v_bat_min_lo	Minimum battery voltage. Low level of hysteresis
v_apl_max_hi	Maximum application voltage. High level of hysteresis
v_apl_max_lo	Maximum application voltage. Low level of hysteresis
V _{cs_hi}	Cold start voltage level
v_ulp_1do	Regulated voltage on VSUP pin
v_hrv_min	Minimum voltage for switching on/off the DCDC. See §5.2.2 for current or voltage detection selection.

Table 1-1 Voltage Naming Conventions

1.4. FUNCTIONAL DESCRIPTION

The following paragraphs describe the behavior of VSTS, VLTS and VSUP for a series of typical use cases; (VAUX supplies have the same behavior as VSUP).

1.4.1. COLD-START ON HARVESTER

This use case outlines a start-up on harvester voltage, with all storage elements discharged or in protection mode.

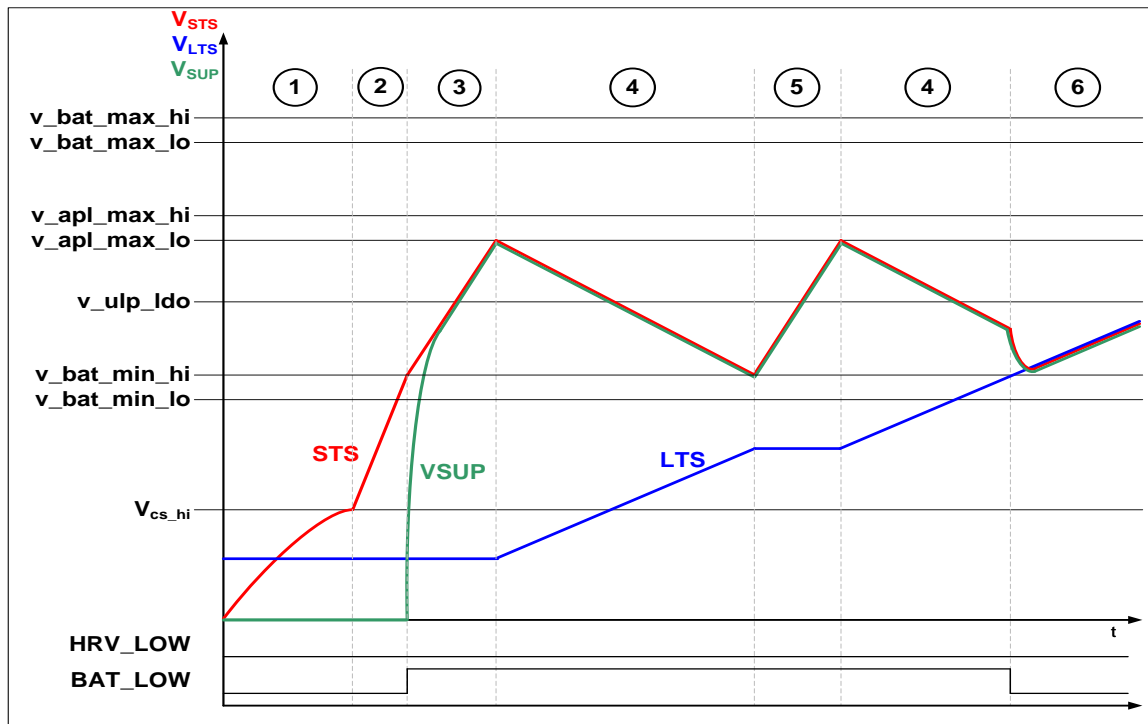

Figure 1-2 Start-up and energy storage sequence when LTS is lower than the cold-start voltage

1. The DCDC starts transferring energy from HRV to STS
2. When V_{STS} is higher than V_{cs_hi} , the cold start sequences ends, the device boots and the DCDC is switched to main charging mode with MPPT tracking.
3. When V_{STS} rises above $v_bat_min_hi$, VSUP is connected to STS supplying the application
4. When V_{STS} reaches the maximum application voltage level $v_apl_max_lo$, the DCDC transfers energy into LTS. The application is supplied by the C_{STS} only.
5. When V_{STS} drops to the minimum pre-defined charge value $v_bat_min_hi$, the DCDC transfers energy back into STS
6. The system remains in states 4 & 5 until V_{LTS} is higher than the minimum battery voltage required to supply the external application $v_bat_min_hi$. Then LTS is connected to STS and both storage elements are charged in parallel. The output BAT_LOW is set to '0'.

1.4.2. START-UP ON LONG TERM STORAGE (LTS)

This case emulates plugging in a partially charged battery with energy form harvester available. The EM8500 starts on LTS voltage, then transfer energy form the harvester to the battery.

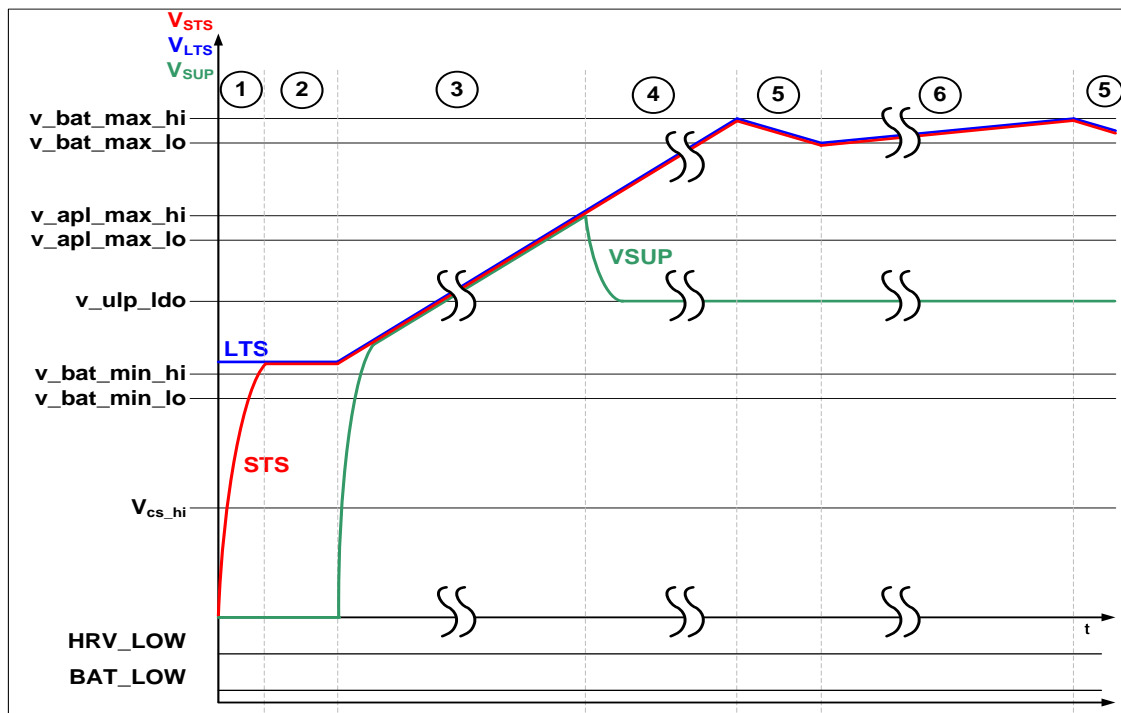

Figure 1-3 Start-up and energy bank sequence when LTS is above the minimum battery level

1. LTS and STS are connected together, V_{STS} quickly reaches V_{LTS} .
2. As V_{STS} reaches V_{CS_HI} , the system boots and then V_{SUP} is connected to STS (which is also connected to LTS).
3. After V_{SUP} reaches V_{LTS} and V_{STS} level, the system reaches the same state as the one described in state 6 of §1.4.1
4. When V_{LTS} (and therefore also V_{STS}) reaches the maximum voltage of the application, V_{SUP} is regulated to v_ulp_ldo .
5. When V_{LTS} and V_{STS} reach $v_bat_max_hi$ the DCDC stops to protect the battery against over voltage
6. When V_{LTS} and V_{STS} drop to $v_bat_max_lo$ the DCDC starts again to charge STS and LTS.
7. The system remains in states 5 & 6 to maintain the battery voltage between $v_bat_max_hi$ and $v_bat_max_lo$.

When a battery charged above the maximum application voltage is connected, the system reacts as above except for V_{SUP} which is regulated from the start due to the too high V_{STS}/V_{LTS} level.

1.4.3. SYSTEM SHUT-DOWN

The EM8500 informs the application when the available energy drops below a minimum level required for operation. After the first warning (through the VBAT_LOW pad), the device initiates an application shut-down sequence to protect the battery.

The first example scenario shows an application drawing more current than the harvester is able to supply. The application is stopped (phase 3). Once re-started, it keeps a low current consumption profile allowing the charging of the LTS energy storage.

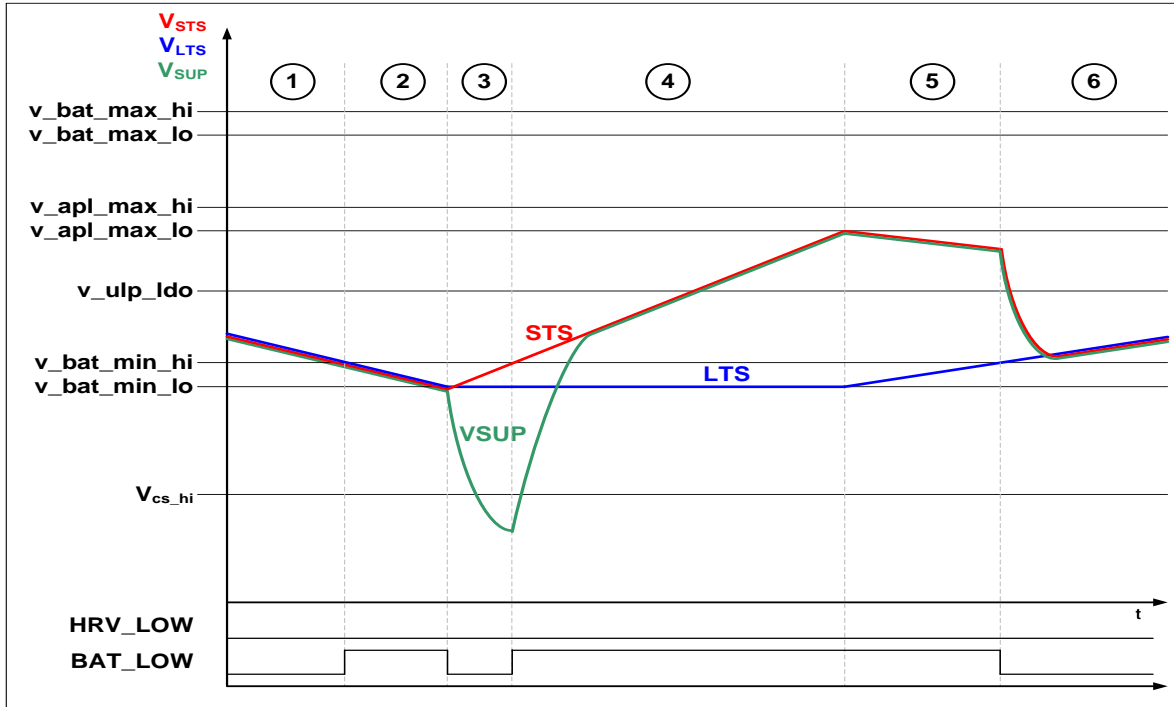

Figure 1-4 Application shut-down with a working harvester

The second example describes the application shut-down sequence when no energy can be harvested from the harvester cell.

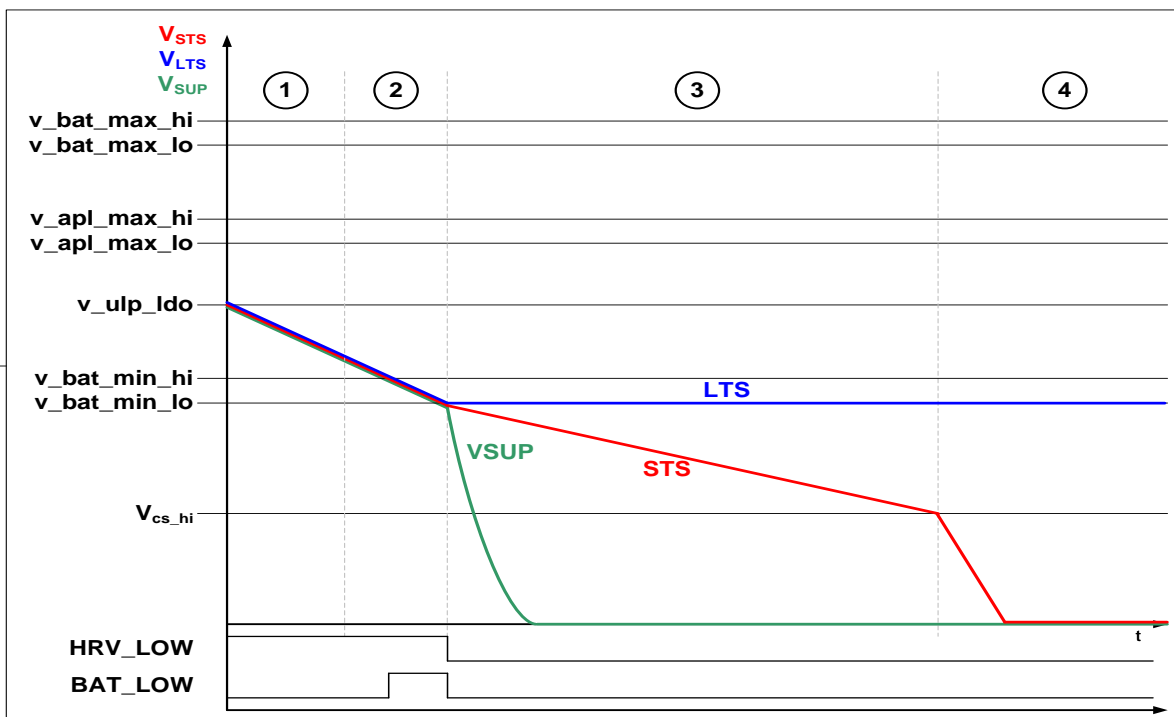

Figure 1-5 Application shut-down without energy from the harvester



2. HANDLING PROCEDURES

This device has built-in protection against high static voltages or electric fields; however, anti-static precautions must be taken as for any other CMOS component. Unless otherwise specified, proper operation can only occur when all terminal voltages are kept within the voltage range. Unused inputs must always be tied to a defined logic voltage level.

3. PIN DESCRIPTION

NO.	PIN		I/O TYPE		DESCRIPTION
	NAME	DIRECTION	SUPPLY		
1	VDD_STS	I/O	–		Connection for the Short Term energy Storage element (STS)
2	WAKE_UP	Input	up to 3.6V		Wake-up pin
3	VDD_USB	Input	–		USB power supply connection
4	MOSI_SDA	Input	VSUP		SPI MOSI or I2C SDA connection
5	MISO	Output	VSUP		SPI MISO connection
6	SCL	Input	VSUP		SPI or I2C clock
7	CS	Input	VSUP		SPI chip select and SPI/I2C selection mode(when at '1')
8	VAUX_GND[2]	Output	–		Auxiliary 2 ground connection
9	VAUX_GND[1]	Output	–		Auxiliary 1 ground connection
10	N.C.				
11	VAUX_GND[0]	Output	–		Auxiliary 0 ground connection
12	VAUX[0]	Output	–		Auxiliary 0 supply output connection
13	VAUX[1]	Output	–		Auxiliary 1 supply output connection
14	VAUX[2]	Output	–		Auxiliary 2 supply output connection
15	N.C.				
16	VSUP	Output	–		Main supply output
17	HRV_LOW	Output	VSUP		Energy harvester cell low indicator (when at '1')
18	BAT_LOW	Output	VSUP		Battery low indicator (when at '1')
19	VREG	Output	–		Regulated voltage connection
20	VSS	Supply	–		Device ground connection
21	VSS_DCDC	Supply	–		Device ground connection
22	LX1	Input	–		Inductor connection for boost converters
23	VDD_HRV	Input	–		Direct connection from energy harvester
24	VDD_LTS	I/O	–		Connection for the Long Term energy Storage element (LTS)

Table 3-1 Pin-out description

The digital pads are all supplied by VSUP, with the exception of the WAKE_UP pad whose trigger levels are independent of the supply voltages. When VSUP is disabled these pads are floating therefore the communication interface is off. All digital pads are active HIGH.



4. ELECTRICAL SPECIFICATIONS

4.1. ABSOLUTE MAXIMUM RATINGS

PARAMETER	VALUE		UNIT
	MIN	MAX	
Power supply VDD_HRV	-0.2	2.0	V
Power supply VDD_STS, VDD_LTS	-0.2	4.6	V
Power supply VDD_USB	-0.2	6.0	V
Input voltage	VSS-0.2	V _{SUP} +0.2	V
Input voltage (pin WAKE_UP)	-0.2	3.8	V
Storage Temperature Range (T _{STG})	-65	150	°C
Electrostatic discharge to ANSI/ESDA/JEDEC JS-001-2012 for HBM	-2000	2000	V

Table 4-1 Absolute maximum ratings

Stresses above these listed maximum ratings may cause permanent damages to the device. Exposure beyond specified operating conditions may affect device reliability or cause malfunction.

Warning: The device is not functional when exposed to light. When a non-packaged version is used, it is mandatory to protect the device from light (e.g. glob-top, non-transparent package, metal shield on the PCB ...)

4.2. OPERATING CONDITIONS

PARAMETER	SYMBOL	MIN	TYP	MAX	UNIT
DC input voltage into VDD_HRV ⁽¹⁾	V _{HRV}	0.1	0.5	1.8	V
Long Term energy Storage bank voltage	V _{LTS}		3.0	4.2	V
Short Term energy Storage bank voltage	V _{STS}		3.0	4.2	V
VDD_USB voltage	V _{USB}		5	5.5	V
Long term capacitor ⁽²⁾	C _{LTS}	0.001	2		F
Short term capacitor	C _{STS}	10	47		µF
Regulated voltage capacitor	C _{REG}	470			nF
Harvester capacitor (nominal value)	C _{HRV}	4.7		10	µF
VSUP capacitor	C _{SUP}	1		0.1°C _{STS}	µF
VAUX capacitor	C _{AUX}	1		0.1°C _{STS}	µF
Input inductance	L ₁	37.6	47	56.4	µH

- (1) Cold-start has been completed
(2) When using a super-capacitor

Table 4-2 Operating Conditions

4.3. ELECTRICAL CHARACTERISTICS

Unless otherwise specified: T_A=-40 to +85°C for min max specifications and T_A= 25°C for typical specifications.

PARAMETER	SYMBOL	CONDITIONS	MIN	TYP	MAX	UNIT
End of cold-start Voltage on VDD_STS	V _{cs_hi}	With V _{STS} increasing		1.3		V
Start of cold-start Voltage on VDD_STS	V _{cs_lo}	With V _{STS} decreasing		1.1		V
Typical DC input voltage range into VDD_HRV		Cold-start completed	0.1		1.8	V
Typical input power range		V _{STS} > V _{cs_hi} V _{VDD_HRV} = 0.5V	0.001		100	mW
Minimum cold-start voltage for charging STS		V _{STS} < V _{cs_lo}		300	1800	mV
Minimum cold-start input power		V _{STS} < V _{cs_lo}		3		µW
Cold-start duration		C _{STS} = 47µF, V _{HRV} = 0.5V, P _{HRV} = 100µW, V _{STS} (0s)=0V, V _{LTS} (0s)=0V, v _{bat_min_hi} =2V		2		s
CURRENT CONSUMPTIONS ON LTS						
IDD in "LTS protection mode" and "HRV low mode"	I _{LTS_prot1}	Battery supervisory at 4Hz; VSUP and VAUX LDOs disabled		65		nA
IDD in "LTS protection mode"	I _{LTS_prot2}	Battery supervisory at 4Hz; VSUP and VAUX LDOs disabled		15		nA
IDD in "HRV low mode" STS and LTS connected	I _{HRV_io2}	Battery supervisory at 4Hz; VSUP and VAUX LDOs disabled		145		nA
IDD in "HRV low mode" STS and LTS connected	I _{HRV_io3}	Battery supervisory at 4Hz; ULP LDO enabled and VAUX LDO disabled		170		nA
IDD in "HRV low mode" STS and LTS connected	I _{HRV_io4}	Battery supervisory at 4Hz; VSUP and VAUX[0] LDO enabled		285		nA
IDD in "HRV low mode" STS and LTS connected	I _{HRV_io5}	Battery supervisory at 4Hz; VSUP and VAUX[1] LDO enabled		265		nA
IDD in "HRV low mode" STS and LTS connected	I _{HRV_io6}	Battery supervisory at 4Hz; VSUP and VAUX[2] LDO enabled		250		nA
IDD in "HRV low mode" STS and LTS connected	I _{HRV_io6}	Battery supervisory at 4Hz; VSUP and all VAUX LDO enabled		380		nA
IDD in "normal mode" STS and LTS disconnected	I _{NORM}	Battery supervisory at 4Hz; VSUP and VAUX LDOs disabled (VDD_STS < VDD_LTS)		45		nA
QUIESCENT CURRENT AND LEAKAGE ON STS (WHEN LTS IS NOT CONNECTED TO STS)						
IDD in "HRV low mode"	I _{sts_hrvlo}	Battery supervisory at 4Hz; VSUP and VAUX LDOs disabled		65		nA
VSUP AND VAUX LDO VOLTAGE LEVEL						
ULP/VAUX LDO level 0		V _{STS} - V _{SUP} > 0.3V	1.08	1.2	1.32	V
ULP/VAUX LDO level 1		V _{STS} - V _{SUP} > 0.3V	1.39	1.55	1.71	V
ULP/VAUX LDO level 2		V _{STS} - V _{SUP} > 0.3V	1.48	1.65	1.82	V
ULP/VAUX LDO level 3		V _{STS} - V _{SUP} > 0.3V	1.62	1.8	1.98	V
ULP/VAUX LDO level 4		V _{STS} - V _{SUP} > 0.3V	1.8	2	2.2	V
ULP/VAUX LDO level 5		V _{STS} - V _{SUP} > 0.3V	1.98	2.2	2.42	V
ULP/VAUX LDO level 6		V _{STS} - V _{SUP} > 0.3V	2.16	2.4	2.64	V
ULP/VAUX LDO level 7		V _{STS} - V _{SUP} > 0.3V	2.34	2.6	2.86	V
MAXIMUM CURRENT ON THE ULP AND VAUX LDO						
Maximum current on ULP LDO		Drop from open voltage is 100 mV, LDO level at 1.8V	10			mA
Maximum current on VAUX[0] LDO		Drop from open voltage is 100 mV, LDO level at 1.8V	20			mA
Maximum current on VAUX[1] LDO		Drop from open voltage is 100 mV, LDO level at 1.8V	10			mA
Maximum current on VAUX[2] LDO		Drop from open voltage is 100 mV, LDO level at 1.8V	5			mA
SWITCH RESISTOR						
VDD_LTS to VDD_STS	R _{sw_LTS_STS}	VDD_STS at 3V		3.1		Ω
VDD_STS to VSUP	R _{sw_VSUP}	VDD_STS at 3V		7.4		Ω
VDD_STS to VAUX[0]	R _{sw_VAUX0}	VDD_STS at 3V		4.4		Ω
VDD_STS to VAUX[1]	R _{sw_VAUX1}	VDD_STS at 3V		5.8		Ω



PARAMETER	SYMBOL	CONDITIONS	MIN	TYP	MAX	UNIT
VDD_ST5 to VAUX[2]	R _{sw_VAUX2}	VDD_ST5 at 3V		6.4		Ω
VAUX_GND[0] to VSS	R _{sw_GND0}	VDD_ST5 at 3V		4.74		Ω
VAUX_GND[1,2] to VSS	R _{sw_GND1,2}	VDD_ST5 at 3V		5.62		Ω
SUPERVISORY LEVELS ON STS, LTS AND HRV⁽¹⁾						
Maximum voltage					4.2	V
Level step from lV10 to lV15	V _{lV_15}			73		mV
Level step from lV16 to lV30 (1.24V to 2.26V)	V _{lV_30}		67.9	73	78.1	mV
Level step from lV31 to lV54 (2.34V to 4.2V)	V _{lV_54}		69.4	73	76.7	mV
Differential non linearity				±0.5		LSB
Number of levels				54		
HARVESTER CURRENT LEVEL DETECTOR – LUX METER						
Harvester current level step	I _{hrv_check_lm}			1		μA
Luxmeter current detection level	I _{lux_lm}			2 ^M		μA
"lV" = level used for the measurement [0..15]						
Short circuit voltage	V _{hrv_scv}			70		mV
USB POWER						
Minimum voltage for USB charging detection	V _{usb_min}			3.5		V
Regulated voltage on VDD_ST5	V _{USB_REG}			2.1		V
Current source level 0 on LTS	I _{usb_lm0}			0		mA
Current source level 1 on LTS	I _{usb_lm1}			6.9		mA
Current source level 2 on LTS	I _{usb_lm2}			12.7		mA
Current source level 3 on LTS	I _{usb_lm3}			20.6		mA
E2PROM PARAMETERS						
E ² PROM write time	T _{ee_wr}				8	ms
E ² PROM read time	T _{ee_rd}				0.9	ms
E2PROM maximum write cycle	N _{ee_cyc}		1000			
E2PROM read hold time	T _{hd_rd}				10	μs
INTERFACE PARAMETERS						
Input WAKE_UP - low level	V _{il_wk}	V _{LTS} =1.2V to 3.6V			0.3	V
Input WAKE_UP - high level	V _{ih_wk}	V _{LTS} = 1.2V to 3.6V	0.9			V
Wake-up rising edge reaction time	T _{r_wk}	Debouncer disabled		4.5		μs
Wake-up falling edge reaction time	T _{f_wk}	Debouncer disabled		120		μs
Input - low level	V _{il_si}	V _{SUP} =1.2V to 3.6V			0.2* V _{SUP}	V
Input - high level	V _{ih_si}	V _{SUP} = 1.2V to 3.6V	0.8* V _{SUP}			V
Output – low level for I2C ⁽³⁾	I _{ol_sda}	V _{SUP} = 1.8V, Vol=0.2* V _{SUP}		3		mA
Output – low level for I2C	I _{ol_sda_1,2}	V _{SUP} = 1.20V, Vol=0.23*V _{sup}		3		mA
Output – low level ⁽³⁾	I _{ol}	V _{SUP} = 1.8V, Vol=0.2*V _{sup} (MISO, MOSI_SDA, BAT_LOW, HRV_LOW)		1		mA
Output – low level	I _{ol_1,2}	V _{SUP} = 1.20V, Vol=0.23*V _{sup} (MISO, MOSI_SDA, BAT_LOW, HRV_LOW)		1		mA
Output – high level ⁽³⁾	I _{oh}	V _{SUP} = 1.8V, Voh=0.8*V _{sup} (MISO, MOSI_SDA, BAT_LOW, HRV_LOW)			-1	mA
Output – high level	I _{oh_1,2}	V _{SUP} = 1.2V, Voh=0.8*V _{sup} (MISO, MOSI_SDA, BAT_LOW, HRV_LOW)			-1	mA
I ² C bus load capacitor	C _b	On MOSI_SDA and SCL			400	pF
SPI TIMINGS						
SPI clock input frequency	F _{spl}				5	MHz
SCL low pulse	T _{low_scl}		20			ns
SCL high pulse	T _{high_scl}		20			ns
MOSI_SDA setup time	T _{setup_mosi}		20			ns
MOSI_SDA hold time	T _{hold_mosi}		20			ns
MISO output delay	T _{delay_miso}	25pF load, V _{SUP} = 1.6V min			30	ns
MISO output delay	T _{delay_miso}	25pF load, V _{SUP} = 1.2V min			40	ns
CS setup time	T _{setup_cs}		50			ns
CS hold time	T _{hold_cs}		20			ns
I²C TIMINGS⁽²⁾						
MOSI_SDA setup time	t _{sudat}	Standard & Fast Modes	160			ns
		High Speed Mode	30			ns
MOSI_SDA hold time	t _{hddat}	Standard & Fast Modes with C _b =100pF Max.	80			ns
		Standard & Fast Modes with C _b =400pF Max	90			ns
		High Speed Mode with C _b =100pF Max.	18		115	ns
		High Speed Mode with C _b =400pF Max.	24		150	ns
SCL low pulse ⁽³⁾	t _{low}	High Speed Mode with C _b =100pF Max.	160			ns
SCL low pulse	t _{low}	High Speed Mode with C _b =100pF Max. V _{SUP} =1.8V				
		High Speed Mode with C _b =100pF Max. V _{SUP} =1.2V	210			ns

- (1) The v_{bat_min}, v_{bat_max}, v_{apl_min} with their hysteresis can be set according to the supervising levels. E.g. for v_{bat_max}, both v_{bat_max_lo} and v_{bat_max_hi} will have to be set accordingly.
- (2) Refers to I²C specification 2.1 (January 2000)
- (3) When reg_ext_cfg.sdi_slope_ctrl = '1'

Table 4-3 Electrical Specifications

4.4. TIMING DIAGRAMS

4.4.1. SPI INTERFACE

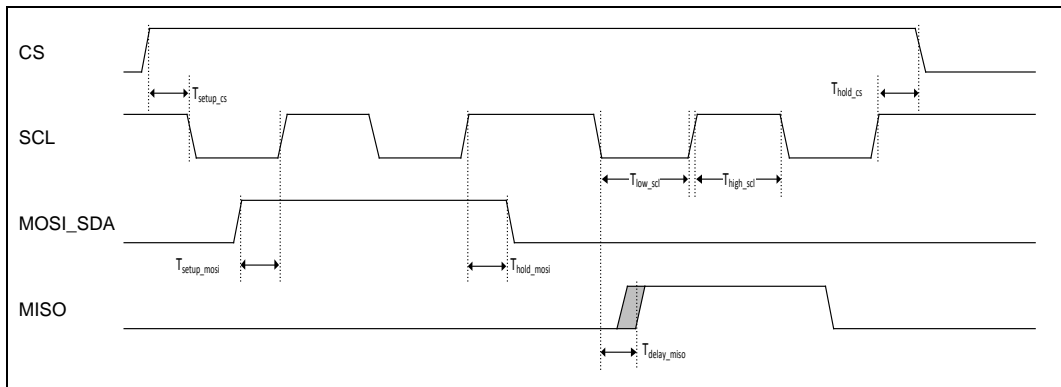

Figure 4-1 4-wire SPI Timing Diagram

4.4.2. I2C INTERFACE

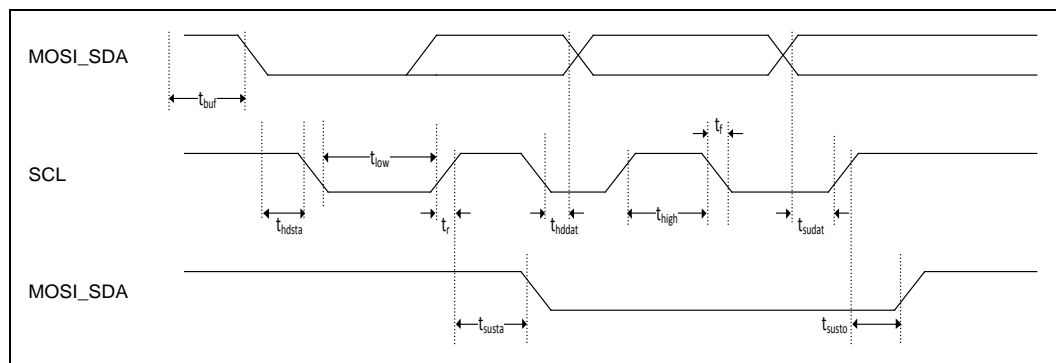

Figure 4-2 I²C Timing Diagram

5. PRODUCT CONFIGURATION

The EM8500 is an autonomous power management system able to manage power domains, power sources and storage elements.

At start-up the device enters a boot sequence. It controls the state of both energy storage elements, and sets the default configuration parameters of the device by retrieving the corresponding values from the on-chip E²PROM.

Upon completion of the boot sequence the system enters the supervising and harvester controller state ("normal mode"). It is now possible to modify configuration parameters through the serial interface to change the behavior of the device. When updating the device configuration through the serial interface it is recommended to write the complete set of EM8500 configuration parameters in a single transaction (see §6).

EM8500 is able to operate autonomously by using default configuration values from the on-chip E²PROM.

5.1. STATUS INFORMATION

EM8500 provides status feed-back as follows.

- To allow fast system response the pins HRV_LOW and BAT_LOW directly indicate the status of the harvester cell and the battery to the host MCU.
- Additional status information is provided through register *reg_status*. During an SPI transaction the *reg_status* value sent as the first byte (along with the indication from the MCU of the address to be accessed). In case of an I2C transaction the *reg_status* register has to be polled explicitly.

Register Name: reg_status				Address: 0x22
Bits	Bit name	Type	Reset	Description
7	eeeprom_data_busy	RO	0	<ul style="list-style-type: none"> '1' EEPROM being written. Wait for new configuration '0' EEPROM ready to be written. New configuration can be written
6	hrv_lux_busy	RO	0	<ul style="list-style-type: none"> '1' lux-meter or HRV current supervisory is running '0' no current measurement on the harvester on-going.
5	hrv_low	RO	0	<ul style="list-style-type: none"> '1' HRV energy level too low for harvesting '0' HRV has enough energy to be harvested
4	bat_low	RO	0	<ul style="list-style-type: none"> '1' LTS voltage lower than v_bat_min_hi in normal mode, lower than v_bat_min_lo in primary cell mode '0' LTS voltage higher than v_bat_min_hi in normal mode, higher than v_bat_min_lo in primary cell mode
3	sw_vdcdc_lts_nsts	RO	0	<ul style="list-style-type: none"> '1' DCDC is charging LTS '0' DCDC is charging STS
2	sw_lts_sts	RO	0	<ul style="list-style-type: none"> '1' LTS and STS are connected '0' STS is disconnected from LTS
1	usb_on	RO	0	<ul style="list-style-type: none"> '1' USB power has been detected '0' No USB power found
0	lts_protect	RO	0	<ul style="list-style-type: none"> '1' LTS protection mode activated ($V_{LTS} < v_bat_min_lo$) '0' LTS protection mode inactive ($V_{LTS} > v_bat_min_lo$)

Table 5-1 Status Register (0x22)

EM8500 offers great flexibility in being configured for different system applications and use cases. The following chapters provide detailed descriptions of all configuration parameters and registers available to the user.

5.2. SUPERVISING AND HARVESTER CONTROLLER BEHAVIOUR

5.2.1. STORAGE ELEMENT

Storage element voltage and state are available through the *reg_vld_status* register.

Register name: reg_vld_status				Address: 0x23
Bits	Bit name	Type	Reset	Description
7	lts_bat_min_hi	RO	0	<ul style="list-style-type: none"> '1' $V_{LTS} > v_bat_min_hi$ '0' $V_{LTS} \leq v_bat_min_hi$
6	lts_bat_min_lo	RO	0	<ul style="list-style-type: none"> '1' $V_{LTS} > v_bat_min_lo$ '0' $V_{LTS} \leq v_bat_min_lo$
5	sts_bat_max_hi	RO	0	<ul style="list-style-type: none"> '1' $V_{STS} > v_bat_max_hi$ '0' $V_{STS} \leq v_bat_max_hi$
4	sts_bat_max_lo	RO	0	<ul style="list-style-type: none"> '1' $V_{STS} > v_bat_max_lo$ '0' $V_{STS} \leq v_bat_max_lo$
3	sts_apl_max_hi	RO	0	<ul style="list-style-type: none"> '1' $V_{STS} > v_apl_max_hi$ '0' $V_{STS} \leq v_apl_max_hi$
2	sts_apl_max_lo	RO	0	<ul style="list-style-type: none"> '1' $V_{STS} > v_apl_max_lo$ '0' $V_{STS} \leq v_apl_max_lo$
1	sts_bat_min_hi	RO	0	<ul style="list-style-type: none"> '1' $V_{STS} > v_bat_min_hi$ '0' $V_{STS} \leq v_bat_min_hi$
0	sts_bat_min_lo	RO	0	<ul style="list-style-type: none"> '1' $V_{STS} > v_bat_min_lo$ '0' $V_{STS} \leq v_bat_min_lo$

Table 5-2 Voltage Status Register (0x23)

Operation of the two energy banks (LTS and STS) is performed through three key voltage threshold levels.

- Minimum battery level voltage **v_bat_min** (*reg_v_bat_min_hi_con* or *reg_v_bat_min_hi_dis* and *reg_v_bat_min_lo*)
- Maximum battery level voltage **v_bat_max** (*reg_v_bat_max_hi* and *reg_v_bat_max_lo*)
- Maximum application level voltage **v_apl_max** (*reg_v_apl_max_hi* and *reg_v_apl_max_lo*)

The three levels include a hysteresis to avoid instability of the controller. The hysteresis values have to be carefully chosen according to the application and have to fulfill the following conditions:

- $v_bat_min_hi_dis > v_bat_min_hi_con > v_bat_min_lo$
- $v_apl_max_hi > v_apl_max_lo$
- $v_bat_max_hi > v_bat_max_lo$

If $v_apl_max \geq v_bat_max$ the application maximum level is considered to be the maximum battery level.

Supervising of the minimum battery level is performed through two registers for its highest control level (*v_bat_min_hi*). When the two battery banks are not connected **v_bat_min_hi_dis** is used to inform the system when it has to charge STS again (see phase 4 to 5 in Figure 1-2 on page 6). When LTS and STS are connected together **v_bat_min_hi_con** is used as supervising level.

The minimum value allowed for the **v_bat_min_hi_dis** register is 0x15 corresponding to typically 1.47 V. For any value lower than this minimum the system may shut-down without notification through the BAT_LOW pin.

All voltage levels with prefix “v_” are configured by register according to the following equation:

$$v_<voltage\ name> = V_{VI} * (reg_<voltage\ name>+1)$$

Supervisory status of the battery is also visible through the pin BAT_LOW. When the V_{LTS} is below **v_bat_min_hi** for two consecutive measurements, BAT_LOW is asserted (set to VSUP level). When two measurements show that V_{LTS} is above **v_bat_min_hi**, BAT_LOW is deasserted (set to VSS). The only exception is during the boot phase where the BAT_LOW signal is asserted after the first measurement of V_{LTS} .

The EM8500 protects the battery when its voltage is too low. This corresponding threshold level can be set through the **v_bat_min_lo** register. When V_{LTS} is falling below this value the EM8500 operates only on the harvester.

5.2.2. HARVESTER POWER SUPERVISORY FUNCTIONS

The EM8500 monitors harvester power to disable DCDC operation when no energy is available.

Two mechanisms for harvester monitoring are available (selectable through *reg_v_hrv_min.hrv_check_vld*) through the same Voltage Level Detector used for the supervision of LTS and STS or through a specific dedicated engine.

- **Voltage detection (used for TEG harvester type):** the threshold level of supervision can be set on the *reg_v_hrv_cfg.v_hrv_min* register. There is no hysteresis on this threshold.
- **Current detection (used for solar harvester type):** The device is sensing the current at the voltage V_{hrv_scv} delivered by the harvester. The current threshold of detection is set through the *reg_hrv_check_lvl.hrv_check_lvl* register to transition from running state to DCDC disable. To return to the running state, the EM8500 detection is done with a different principle. The current measurement is done by connecting a resistance on VDD_HRV and sense voltage on this pin using **v_hrv_min** voltage level.

Resistances and currents are defined in *reg_hrv_check_lvl.hrv_check_lvl*:

<i>reg_hrv_check_lvl.hrv_check_lvl</i>	0x00	0x01	0x02	0x03	0x04	0x05	0x06	0x07	0x08	0x09	0x0A	0x0B	0x0C	0x0D	0x0E	0x0F
Current (µA)	1	2	3	4	5	6	7	8	9	10	11	12	13	14	15	16
Resistance (kΩ)	35	23.3	17.5	14	11.7	10	8.75	7.8	7	6.36	5.38	5.4	5	4.7	4.4	4.4

Table 5-3 HRV Current Detection Levels

Configuration example:

- *reg_hrv_check_lvl* = 0x00; *reg_v_hrv_cfg* = 0x00

The system indicates HRV_LOW = '1' from 1µA at V_{hrv_scv} (70mV) and remains off until V_{VI} is reached with 35 kΩ load on VDD_HRV (2 µA at V_{VI}). A hysteresis of 1 µA is applied.

Register name: <i>reg_v_hrv_cfg</i>			Address: 0x04	Default value mapped in E ² PROM
Bits	Bit name	Type	Description	
7	–	–	Reserved	
6	<i>hrv_check_vld</i>	RW	<ul style="list-style-type: none"> • '1' indicates that the HRV is checked by the voltage supervisory • '0' indicates that the HRV is checked by the current supervisory 	
5:0	<i>v_hrv_min</i>	RW	Minimum HRV open voltage required to generate energy. $V_{hrv_min} = V_{VI} * (reg_v_hrv_min(5:0)+1)$ if $V_{HRV} < V_{hrv_min}$ and <i>reg_v_hrv_cfg.hrv_check_vld</i> = '1' then <i>reg_status.hrv_low</i> = '1'	

Table 5-4 Minimum HRV voltage (0x04)

Register name: reg_hrv_check_lvl			Address: 0x05	Default value mapped in E ² PROM
Bits	Bit name	Type	Description	
7:4	–	–	Reserved	
3:0	hrv_check_lvl	RW	Minimum HRV short-cut current level to generate energy. $I_{hrv_check} = (hrv_check_lvl+1) * 1\mu A$ if $I_{HRV} < I_{hrv_check}$ and $reg_v_hrv_cfg.hrv_check_vld = '0'$ then $reg_status.hrv_low = '1'$	

Table 5-5 Minimum HRV short-cut current (0x05)

When LTS and STS are not connected internally (in “primary cell mode” or in “battery protection mode”) the DCDC booster is able to deliver up to around 1mW maximum to the application. This value depends on input (VDD_HRV) and output (VDD_STS) voltages.

5.2.3. TIMING CONFIGURATION

In addition to voltage level supervision, the user can select independent values for the frequency of supervision on LTS, STS and the harvester. The frequency influences the overall EM8500 power consumption and therefore its efficiency.

The STS and LTS measurement periods are set through the registers *reg_t_sts_period* and *reg_t_lts_period*. The monitoring of the harvester however requires stopping the DCDC pumping process for a short time to measure the open voltage (in case the VLD is used) or the short-cut current (in case the current level detector is used). The duration of the DCDC disable period is configured through the *reg_t_hrv_meas* register, whereas the measurement period is configured through the *reg_t_hrv_period* register.

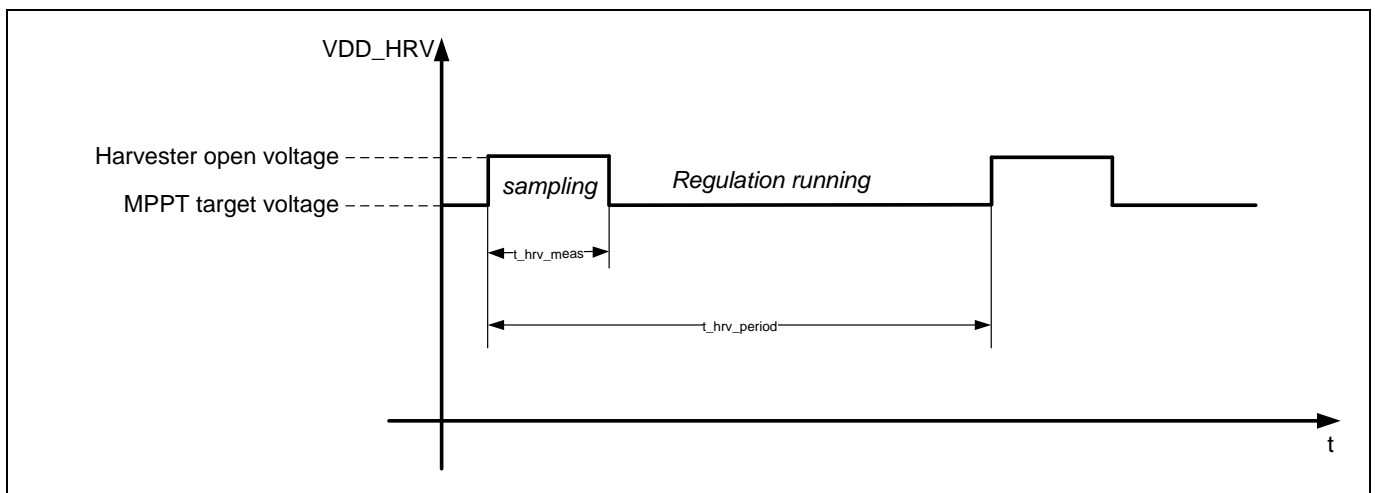
Figure 5-1 DCDC Regulation Timings

Register value	t_hrv_meas	t_hrv_period	t_sts_period	t_lts_period	t_hrv_low_period	t_lts_hrv_low_period
0x00	16 ms	256 ms	1 ms	1 ms	256 ms	2 ms
0x01	32 ms	512 ms	2 ms	4 ms	512 ms	8 ms
0x02	64 ms	1 s	8 ms	16 ms	1 s	32 ms
0x03	128 ms	2 s	16 ms	64 ms	2 s	128 ms
0x04	256 ms	4 s	32 ms	256 ms	4 s	512 ms
0x05	512 ms	8 s	64 ms	1 s	8 s	2 s
0x06	1 s	16 s	128 ms	4 s	16 s	8 s
0x07	2 s	32 s	256 ms	16 s	32 s	32 s

Table 5-6 Timing Configuration

When entering in “HRV low mode” the monitoring on LTS and the harvester remains active, however the monitoring frequency can be adapted to this situation where the system cannot take energy anymore from the harvester source. The measurement period is then set in parameter **t_hrv_low_period**. In this mode STS is not fed by the harvester anymore. If STS and LTS are not connected internally, STS will collapse. No monitoring is performed on STS.

When the harvester is monitored (*reg_v_hrv_cfg.hrv_check_vld*) based on the voltage measurement, the sampling value is set at the same frequency as the harvester voltage check. However, if the current level detector is used, the measurement of the current is done alternatively with the MPPT target setting, dividing by 2 the effective frequency of measurement and setting. For example if T_{hrv_period} is set to 4 s, the period for checking the harvester voltage is 8 s, as well as the one for the MPPT target setting, and the harvester current checking is done 4 s after the MPPT target setting.

5.2.4. MAXIMUM POWER POINT TRACKING

To efficiently cope with different DC sources EM8500 offers a configurable MPPT controller. The MPPT target ratio for the DCDC boost converter can be set between 50% (suitable for TEG sources) and 88% (80% being a standard value for solar cells). The ratio is programmed in register *reg_mppt_ratio*.

Register name: <i>reg_mppt_ratio</i>			Address: 0x12	Default value mapped in E ² PROM
Bits	Bit name	Type	Description	
7:4	–	–	Reserved	
3:0	<i>mppt_ratio</i>	RW	MPPT ratio for the DCDC power point tracking <ul style="list-style-type: none"> • "0000" (0x0) 50% • "0001" (0x1) 60% • "0010" (0x2) 67% • "0011" (0x3) 71% • "0100" (0x4) 75% • "0101" (0x5) 78% • "0110" (0x6) 80% • "0111" (0x7) 82% • "1000" (0x8) 83% • "1001" (0x9) 85% • "1010" (0xA) 86% • "1011" (0xB) 87% • "11--" (0xC to 0xF) 88% 	

Table 5-7 MPPT Ratio Selection Register (0x12)

5.3. POWER MANAGEMENT FUNCTIONS

The EM8500 controls four independent power supply outputs.

The VSUP power supply output is connected to STS when STS level is within the application voltage range (*v_bat_min*:*v_apl_max*) or to an LDO (when above *v_apl_max*) to regulate the output to a given value.

The three auxiliary supply outputs VAUX [0:2], are user configurable between STS and the internal LDO. It is possible to force the use of the LDO even though the STS voltage level is compatible with the application supply requirements.

During the boot phase – which corresponds to the set-up of the device – all the power supply outputs are floating. Once the set-up of the registers is completed the supply output values are determined by configuration registers *reg_ldo_cfg.vsup_tied_low* and *reg_vaux_cfg.vaux[x]_cfg*.

The main application power supply (VSUP) is intended to be connected to the application controller. When connected to the LDO its maximum power is limited as LDO is optimized for low consumption. The VSUP supply output is controlled by the *reg_ldo_cfg* register. The value of the LDO is configurable through *reg_ldo_cfg.v_ulp_ldo*. The LDO enable can be forced with *reg_ldo_cfg.frc_ulp_ldo*. In "sleep state", VSUP can be grounded (*reg_ldo_cfg.vsup_tied_low* = '1') or floating (*reg_ldo_cfg.vsup_tied_low* = '1') (see §5.4).

The individual configurability of the three auxiliary supply outputs allows the creation of different power domains for the external application. The auxiliary outputs are split into the supply and ground pins where all six outputs can be switched on/off independently. The behavior of the VAUX pins is controlled through the *reg_vaux_cfg* register. *reg_vaux_cfg.v_aux_ldo* controls the level of the single LDO connected to the three auxiliary supplies.

When switched on (*reg_pwr_mgt.vaux[i]_en* = '1') the auxiliary supply output is controlled by *reg_vaux_cfg.vaux[i]_cfg*.

Four possible settings are available to the user:

- 1) Force the connection to STS
- 2) Force the connection to the LDO
- 3) Use the automatic configuration permitting the auxiliary output to float when STS drops below *v_bat_min*
- 4) Use the automatic configuration grounding the auxiliary output when STS drops below *v_bat_min*

The automatic configuration of the auxiliary supplies ensures that the auxiliary output voltage is kept within the application voltage range by auto-connecting the supply output to the LDO when STS voltage is exceeding the *v_apl_max* value.

When the power supply output is switched off (*reg_pwr_mgt.vaux[i]_en* = '0'), its configuration is also controlled by the *reg_pwr_mgt.vaux[i]_cfg* register. The output is grounded if *reg_pwr_mgt.vaux[i]_cfg* is set to 3 (b11), otherwise it is kept floating.

When the LDO is used on VSUP or VAUX pins, changing the LDO settings does not generate over or under shoots on the output power supply terminals.

EM8500 offers the possibility to control the ground pin as part of the application, by connecting it to the ground of the EM8500 or letting it float. It is of particular interest when involving applications that are using I²C communication through the pulls of the I²C lines. The configuration of the VAUX_GND pins is controlled through the *reg_pwr_mgt.vaux_gnd[i]_en* register.

Register name: reg_ldo_cfg			Address: 0x0E	Default value mapped in E ² PROM
Bits	Bit name	Type	Description	
7	vsup_tied_low	RW	When set to '1', connects VSUP pin to ground when VSUP is disabled, otherwise VSUP remains floating.	
6:4	v_vaux_ldo	RW	VAUX LDO regulated voltage selection <ul style="list-style-type: none"> • "000" (0) 1.2 V • "001" (1) 1.55 V • "010" (2) 1.65 V • "011" (3) 1.8 V • "100" (4) 2.0 V • "101" (5) 2.2 V • "110" (6) 2.4 V • "111" (7) 2.6 V 	
3	frc_ulp_ldo	RW	Force ULP LDO on as soon as $V_{STS} > v_bat_min_hi$	
2:0	v_ulp_ldo	RW	ULP LDO regulated voltage selection <ul style="list-style-type: none"> • "000" (0) 1.2 V • "001" (1) 1.55 V • "010" (2) 1.65 V • "011" (3) 1.8 V • "100" (4) 2.0 V • "101" (5) 2.2 V • "110" (6) 2.4 V • "111" (7) 2.6 V 	

Table 5-8 VSUP output supply and LDOs configuration register (0x0E)

Register name: reg_pwr_cfg			Address: 0x0F	Default value mapped in E ² PROM
Bits	Bit name	Type	Description	
7	usb_ldo_frc_dis	RW	<ul style="list-style-type: none"> • '1' Disable USB LDO after boot sequence even if usb_crt_src_sel is > 0x0 • '0' Keep the default behavior on USB LDO 	
6	dis_vaux_gnd2_hrv_low	RW	<ul style="list-style-type: none"> • '1' open the VAUX_GND[2] (pin is floating) in "HRV low" mode. • '0' Keep the same behavior as in normal mode 	
5	dis_vaux_gnd1_hrv_low	RW	"HRV low" mode VAUX_GND[1] behavior. same as for pin VAUX_GND[2]	
4	dis_vaux_gnd0_hrv_low	RW	"HRV low" mode VAUX_GND[0] behavior. same as for pin VAUX_GND[2]	
3	dis_vaux2_hrv_low	RW	<ul style="list-style-type: none"> • '1' Disable vaux[2] in "HRV low" mode. It is configured by <i>reg_vaux_cfg.vaux2_cfg</i> • '0' Keeps its normal mode configuration. 	
2	dis_vaux1_hrv_low	RW	"HRV low" mode VAUX[1] behavior. same as for pin VAUX[2]	
1	dis_vaux0_hrv_low	RW	"HRV low" mode VAUX[0] behavior. same as for pin VAUX[2]	
0	dis_vsup_hrv_low	RW	<ul style="list-style-type: none"> • '1' Disable VSUP in "HRV low" mode. Its behavior is defined by <i>reg_ldo_cfg.vsup_tied_low</i> • '0' Keeps its normal mode configuration 	

Table 5-9 "HRV low" mode power switch configuration register (0x0F)

Register name: reg_vaux_cfg			Address: 0x10	Default value mapped in E ² PROM
Bits	Bit name	Type	Description	
7:6	–	–	Reserved	
5:4	vaux2_cfg	RW	Configuration of VAUX[2] pin <ul style="list-style-type: none"> • "00" (0) Constantly connected to STS • "01" (1) Constantly connected to the LDO • "10" (2) Automatic configuration – floating when below $V_{STS} < v_bat_min$ • "11" (3) Automatic configuration – grounded when below $V_{STS} < v_bat_min$ If VAUX[2] is disconnected – VAUX[2] is connected to ground if the value is "11", otherwise it is floating	
3:2	vaux1_cfg	RW	Configuration of VAUX[1] pin – same as for VAUX[2] pin	
1:0	vaux0_cfg	RW	Configuration of VAUX[0] pin – same as for VAUX[2] pin	

Table 5-10 Auxiliary supply configuration register (0x10)

Register name: reg_vaux_gnd_cfg			Address: 0x11	Default value mapped in E ² PROM
Bits	Bit name	Type	Description	
7:3	–	–	Reserved	
2	vaux_gnd2_cfg	RW	<ul style="list-style-type: none"> '1' Auto disconnect when V_{STS} not within [v_bat_min.. v_apl_max] '0' Fully manual connection 	
1	vaux_gnd1_cfg	RW	Configuration of VAUX_GND[1] pin – same as for VAUX_GND [2] pin	
0	vaux_gnd0_cfg	RW	Configuration of VAUX_GND[0] pin – same as for VAUX_GND[2] pin	

Table 5-11 Auxiliary ground pins configuration register (0x11)

Register name: reg_pwr_mgt			Address: 0x19	Value at start-up mapped in E ² PROM
Bits	Bit name	Type	Description	
7	frc_prim_dcdc_dis	RW	<ul style="list-style-type: none"> '1' Force the DCDC off '0' Keep the automatic mode of the DCDC 	
6	vaux_gnd2_en	RW	Enable the VAUX_GND[2] connection (see reg_vaux_gnd_cfg.vaux_gnd2_cfg) when $V_{STS} > v_bat_min_hi$	
5	vaux_gnd1_en	RW	Enable the VAUX_GND[1] connection (see reg_vaux_gnd_cfg.vaux_gnd0_cfg) when $V_{STS} > v_bat_min_hi$	
4	vaux_gnd0_en	RW	Enable the VAUX_GND[0] connection (see reg_vaux_gnd_cfg.vaux_gnd0_cfg) when $V_{STS} > v_bat_min_hi$	
3	vaux2_en	RW	Enable the VAUX[2] connection (see reg_vauxcfg.vaux2_cfg) when $V_{STS} > v_bat_min_hi$	
2	vaux1_en	RW	Enable the VAUX[1] connection (see reg_vauxcfg.vaux1_cfg) when $V_{STS} > v_bat_min_hi$	
1	vaux0_en	RW	Enable the VAUX[0] connection (see reg_vauxcfg.vaux0_cfg) when $V_{STS} > v_bat_min_hi$	
0	sleep_vsups	RW	Enable the VSUP "sleep state" – disconnects VSUP for t_sleep_vsups interval	

Table 5-12 Power switch enable register (0x19)

5.4. PRIMARY CELL CONFIGURATION

The EM8500 supports supplying an application through a combination of a primary cell and a harvesting element by setting reg_lts_cfg.prim_cell to '1'.

In this case the application is mainly supplied by STS. LTS is automatically connected to STS as soon as the harvesting element is not providing enough energy to supply the application. LTS is disconnected from STS as soon as the harvester provides enough energy to the system again.

LTS and STS are connected automatically when HRV_LOW is asserted, or if after a measurement of V_{STS} below v_bat_min_hi_dis, a successive measurement (1 ms later) on STS confirms that the level is still below v_bat_min_hi_dis. The connection remains for two periods of HRV measurements.

If the battery level is below v_bat_min_lo STS and LTS are kept disconnected to avoid damaging the battery cell.

The checks on the harvester and STS are done with the same frequencies as shown in §5.2.1.

It is possible to force the connection between STS and LTS, preventing the use of the DCDC converter to harvest energy from the harvester cell – reg_lts_cfg.prim_cell_connect = '1'. This is particularly useful to perform high energy tasks.

When the device is in LTS protect mode (reg.status.lts_protect = '1') forcing the primary cell connection has no effect. The system continues to be supplied by the harvester. Forcing a connection leads to the collapse of the supply as the battery is too low.

By permanently connecting STS and LTS it is also possible to use only a primary cell (without harvester) and taking advantage of the EM8500 power management features to control the 4 power supply domains and their automated nodes.

Register name: reg_lts_cfg			Address: 0x06	Default value mapped in E ² PROM
Bits	Bit name	Type	Description	
7:3	–	–	Reserved	
2	prim_cell_connect	RW	<ul style="list-style-type: none"> '1' Connect LTS and STS if reg_lts_cfg.prim_cell = '1'. '0' Normal mode on STS 	
1	prim_cell	RW	<ul style="list-style-type: none"> '1' Sets the device in primary cell mode. The DCDC never charges LTS '0' Sets the device in secondary cell mode (LTS is rechargeable) 	
0	no_bat_protect	RW	<ul style="list-style-type: none"> '1' Disables the battery protection feature. (reg.status.lts_protect = '0') '0' Enables the battery protection feature. 	

Table 5-13 LTS configuration register (0x06)

When the primary cell mode is selected the lux-meter function can only be used when both LTS and STS are forced to be connected together – *reg_lts_cfg.prim_cell_connect = '1'*.

5.5. SLEEP MODE AND WAKE-UP FUNCTIONS

In addition to the direct control of the power supply outputs the EM8500 supports stopping supplying the application (switching off VSUP) for a given time interval to allow very low consumption modes. When enabled, the auxiliary supplies are kept in the same state as before entering in the “sleep state”. The “sleep state” is not a functional mode of the power management unit, as the device is still working according to the configuration parameters set and is only acting on the state of the VSUP supply output.

The “sleep state” can also be interrupted (VSUP is connected again on STS or on the LDO according to the settings of the VSUP power switch see Table 5-8) by setting the WAKE_UP pin to a level above V_{in_wk} .

During “sleep state” the serial interface is disabled.

To avoid false wake-up detection, a debouncing logic is connected to the WAKE_UP pin. The debouncer function is enabled by default (factory default value on E²PROM), and can be disabled by setting the *reg_ext_cfg.wake_up_deb_en* to '0'. The wake-up is sensitive to the edge configured in *reg_ext_cfg.wake_up_edge_cfg*. It is not permitted to set *reg_ext_cfg.wake_up_edge_cfg = "00"*.

Register name: <i>reg_ext_cfg</i>			Address: 0x13	Default value mapped in E ² PROM
Bits	Bit name	Type	Description	
7	<i>sda_slopectrl</i>	RW	MOSI_SDA pad slope control <ul style="list-style-type: none"> '0' for standard and fast I2C mode, and high speed mode if VSUP < 1.8V '1' for high speed mode if VSUP > 1.8V 	
6	<i>wake_up_deb_en</i>	RW	When at '1' the wake-up debouncer is enabled	
5:4	<i>wake_up_edge_cfg</i>	RW	"00" (0x0): Forbidden "01" (0x1): wake-up on falling edge "10" (0x2): wake-up on rising edge "11" (0x3): wake-up on both edge	
3	<i>usb_frc_hrv_low_hiz</i>	RW		
2	<i>usb_frc_bat_low_hiz</i>	RW		
1:0	<i>usb_crt_src_sel</i>	RW		

Table 5-14 Wake-up terminal configuration register (0x13)

The “sleep state” duration is controlled through a 24-bit counter (*reg_t_sleep_vsup[23:0]*). VSUP supply can be interrupted for up to 4 hours, with a granularity of 1 ms.

$$t_sleep_vsup = reg_t_sleep_vsup[23:0] / 1000 \text{ seconds}$$

When VSUP is in “sleep state” it is possible to ground VSUP to create a known voltage level on the main controller supply, by setting *reg_ldo_cfg.vsup_tied_low* to '1' (see above in page 17).

The VSUP “sleep state” is enabled by setting *reg_pwr_mgt.sleep_vsup* to '1' (see Table 5-12 bit 0).

Register name: <i>reg_t_sleep_vsup_lo</i>			Address: 0x14	Default value mapped in E ² PROM
Bits	Bit name	Type	Description	
7:0	<i>t_sleep_vsup_lo</i>	RW	Sleep counter duration – least significant byte	

Table 5-15 VSUP “sleep state” counter time-out Least significant byte (0x14)

Register name: <i>reg_t_sleep_vsup_mid</i>			Address: 0x15	Default value mapped in E ² PROM
Bits	Bit name	Type	Description	
7:0	<i>t_sleep_vsup_mid</i>	RW	Sleep counter duration – byte 2	

Table 5-16 VSUP “sleep state” counter time-out middle significant byte (0x15)

Register name: <i>reg_t_sleep_vsup_hi</i>			Address: 0x16	Default value mapped in E ² PROM
Bits	Bit name	Type	Description	
7:0	<i>t_sleep_vsup_hi</i>	RW	Sleep counter duration – most significant byte	

Table 5-17 VSUP “sleep state” counter time-out Most significant byte (0x16)

5.6. LUX-METER

The device contains this specific element to determine ranges of current supplied by the harvesting element.

The lux-meter is able to run in three modes:

- Fully automatic mode
- Automatic range selection
- Fully manual mode

In fully automatic mode (selected by writing '1' in *reg_lux_meter_cfg.lux_meter_auto_meas*) the device determines the value range for the current flowing in from the harvesting element. The result is available in the *reg_lux_meter_result.lux_meter_result* register field. The *reg_lux_meter_result.lux_meter_busy* bit indicates that the measurement is still ongoing and that the result is not available yet.

In automatic range selection mode (selected by writing '1' in *reg_lux_meter_cfg.lux_meter_auto_rng*) the EM8500 automatically determines the optimal range, and measures the voltage at VDD_HRV for maximum precision. The *reg_lux_meter_result.lux_meter_busy* bit indicates that the range search is complete. In this mode lux-meter continues to operate until user disabled by writing '0' into the *reg_lux_meter_cfg.lux_meter_auto_rng*.

The full manual mode allows the user to select the range. The mode is selected by writing on the bit *reg_lux_meter_cfg.lux_meter_manu* – '1' to activate the mode, and '0' to deactivate it. The selection of the range is done through the *reg_lux_meter_cfg.lux_meter_rng* field.

In case a lux-meter action is requested with LTS and STS disconnected, $V_{LTS} < v_bat_min_lo$ or – in primary cell mode – when *reg_lts_cfg.prim_cell_connect* = '0' the action is disregarded and the result – in automatic mode – is invalid.

Register name: <i>reg_lux_meter_cfg</i>				Address: 0x1C
Bits	Bit name	Type	Reset	Description
7	–	–	0	Reserved
6	<i>lux_auto_meas</i>	OS	0	Start the automatic lux-meter measurement. The lux-meter is disabled automatically when the measure is finished
5	<i>lux_auto_rng</i>	RW	0	Enable the lux-meter, and search for the best range. It remains enabled
4	<i>lux_manu</i>	RW	0	Enable the lux-meter in manual mode (range forced by <i>reg_lux_meter_cfg.lux_lv</i>)
3:0	<i>lux_lv</i>	RW	0x0	Target current level to be detected <ul style="list-style-type: none"> • "0000" (0x0) 1 μA • "0001" (0x1) 2 μA • "0010" (0x2) 4 μA • "0011" (0x3) 8 μA • "0100" (0x4) 15 μA • "0101" (0x5) 30 μA • "0110" (0x6) 60 μA • "0111" (0x7) 120 μA • "1000" (0x8) 0.25 mA • "1001" (0x9) 0.5 mA • "1010" (0xA) 1 mA • "1011" (0xB) 1.8 mA • "1100" (0xC) 3.2 mA • "1101" (0xD) 6 mA • "1110" (0xE) 11 mA • "1111" (0xF) 17 mA

Table 5-18 Lux Meter Configuration Register (0x1C)

Register name: reg_lux_meter_result				Address: 0x1D
Bits	Bit name	Type	Reset	Description
7:5	–	–	'000'	Reserved
4	lux_meter_busy	RO	0	Indicates that the lux-meter is still searching for best range
3:0	lux_meter_result	RO	0x0	Lux-meter range status (result in automatic measurement mode) <ul style="list-style-type: none"> • "0000" (0x0) below 2 μA • "0001" (0x1) from 2 μA to 4 μA • "0010" (0x2) from 4 μA to 8 μA • "0011" (0x3) from 8 μA to 15 μA • "0100" (0x4) from 15 μA to 30 μA • "0101" (0x5) from 30 μA to 60 μA • "0110" (0x6) from 60 μA to 120 μA • "0111" (0x7) from 120 μA to 0.25 mA • "1000" (0x8) from 0.25 mA to 0.5 mA • "1001" (0x9) from 0.5 mA to 1 mA • "1010" (0xA) from 1 mA to 1.8 mA • "1011" (0xB) from 1.8 mA to 3.2 mA • "1100" (0xC) from 3.2 mA to 6 mA • "1101" (0xD) from 6 mA to 11 mA • "1110" (0xE) from 11 mA to 17 mA • "1111" (0xF) above 17 mA

Table 5-19 Lux-meter Result Register (0x1D)

5.7. USB CHARGING

The EM8500 is equipped with a USB power line input to supply the device and to charge has the energy bank elements.

When a voltage above V_{usb_min} is detected, a regulator between VDD_USB and VDD_STS is enabled. The regulated voltage is V_{usb_reg} . In addition to the regulator, a current source is activated between VDD_USB and VDD_LTS. This function is controlled by the *reg_ext_cfg* register. Four user selected level of charge current delivered to LTS are available (*reg_ext_cfg.usb_crt_src_sel*).

When VDD_USB is connected, pins HRV_LOW and BAT_LOW can be brought into HiZ state.

Register name: reg_ext_cfg			Address: 0x13	Default value mapped in E ² PROM
Bits	Bit name	Type	Description	
7	sda_slopectrl	RW		
6	wake_up_deb_en	RW		
5:4	wake_up_edge_cfg	RW		
3	usb_frc_hrv_low_hiz	RW	<ul style="list-style-type: none"> • '1' force HRV_LOW in Hi-Z state if usb_on = '1' • '0' HRV_LOW pin standard configuration 	
2	usb_frc_bat_low_hiz	RW	<ul style="list-style-type: none"> • '1' force BAT_LOW in Hi-Z state if usb_on = '1' • '0' BAT_LOW pin standard configuration 	
1:0	usb_crt_src_sel	RW	USB power current source selection <ul style="list-style-type: none"> • "00" (0x0) 0 mA (do not charge) • "01" (0x1) 5 mA • "10" (0x2) 10 mA • "11" (0x3) 20 mA 	

Table 5-20 USB Configuration Register (0x13)

Warning: When VDD_LTS is to be disconnected from its load, the USB current injected into LTS must be set to 0 mA, otherwise the device could be damaged.

5.8. MISCELLANEOUS FUNCTIONS

This chapter describes additional control functions related to the regulation loop.

5.8.1. SOFT RESET FUNCTION

The soft reset function restarts the EM8500 from its boot sequence. The behavior of the EM8500 is the same as in a normal boot sequence. A soft reset is generated by setting the register *reg_soft_res_word* to 0xAB. This register is enabled only if *reg_protect_key* is set to 0xE2. If the value of the *reg_protect_key* is different from 0xE2, the register *reg_soft_res_word* is set to 0x00.

The *reg_protect_key* register is reset by the soft reset. Creating a new soft sequence requires preloading the *reg_protect_key* again.

Register name: <i>reg_soft_res_word</i>				Address: 0x1A
Bits	Bit name	Type	Reset	Description
7:0	<i>soft_res_word</i>	RW	0x00	Force reset when set at 0xAB

Table 5-21 Soft reset register (0x1A)

Register name: <i>reg_protect_key</i>				Address: 0x1B
Bits	Bit name	Type	Reset	Description
7:0	<i>protect_key</i>	RW	0x00	Allow writing on <i>reg_soft_res_word</i> register when set at 0xE2 Allow writing on protected registers when set at 0x4B Allow writing on E2PROM when set at 0xA5

Table 5-22 Protected registers key (0x1B)

5.8.2. REGISTER PROTECTION

The EM8500 functionality is determined by the content of the configuration registers (like the supervising levels or periods). The registers are always accessible in read mode. Some registers are write protected against unwanted write operations.

The registers ranging is address space from 0x00 to 0x18 are write protected. Writing into these registers is enabled after setting *reg_protect_key* to 0x4B.

Note: The *reg_protect_key* is reset at the end of the communication transaction (see §6 on page 22). It is necessary to set it on the same communication transaction – on SPI keeping CS to '1' or on I²C before putting a I²C stop.

Write access to the on-chip E²PROM is controlled by the same mechanism. Prior to a write operation into the E²PROM *reg_protect_key* must be set to 0xA5.

5.8.3. LTS PROTECTION DISABLE

By default the EM8500's monitors voltage levels, namely lower voltage limit, to prevent damage to the LTS energy storage element.

This protection can be disabled by setting register *reg_lts_cfg.no_bat_protect* leaving the system connected to LTS even when the voltage level drops below *v_bat_min*. Disabling protection might be suitable for systems using super-caps or solid-state battery storage elements.

When LTS protection is active the EM8500 tries to start-up from LTS only once, if after booting it still detects that $V_{LTS} < v_{bat_min}$ it enables the protection and never try to restart from LTS. The system will then re-start as from a standard cold-start.

5.8.4. DCDC OFF FORCING

It is possible to stop the regulation loop by explicitly forcing the DCDC to stop its pumping operation. To stop the DCDC it is necessary to set the bit *reg_pwr_mgt.frc_prim_dcdc_dis* to '1' (see Table 5-12). De-asserting this bit (write it to '0') will re-enable the DCDC to its normal operation.

6. SERIAL INTERFACE

The EM8500 offers SPI and I²C serial interfaces selected by the CS pin.(see §6.2.1).

The configuration/function of the EM8500 is updated only after the end of a communication transaction. An SPI transaction is defined by all the bytes sent and received when the pad CS is kept to '1'. An I²C transaction is defined by all the data sent or received between a start and a stop I²C patterns.

Data synchronization between the communication interface and the internal part of the device is done at the end of a supervising loop. New information is active two milliseconds after the end of the transaction. All write transactions sent before the end of this synchronization interval are ignored. It is recommended to perform the device configuration in one transaction. Read transactions are allowed at any time.

6.1. I2C INTERFACE

The I²C slave interface is compatible with Philips I²C Specification version 2.1 (see specific timings on electrical specifications chapter). All modes (standard, fast, high speed) are supported. MOSI_SDA and SCL pins are not strictly open-drain (they represent diodes to VSUP).

The 7-bit device address is defined in the E²PROM (at address 0x58). This address is copied at boot into the *reg_spi_i2c_cfg.ic2_addr* register field.

The I²C bus uses the 2 wires SCL (Serial Clock) and MOSI_SDA. CS has to be connected to VSS. MOSI_SDA is bi-directional with open drain to VSS: it must be externally connected to VSUP via a pull up resistor.

The I2C interface supports single and multiple read and write transactions.

In the following figures, "S" indicates the I²C transaction start, "P" indicates the I²C transaction stop.

The multi-read and multi write transactions are described in the following figures.

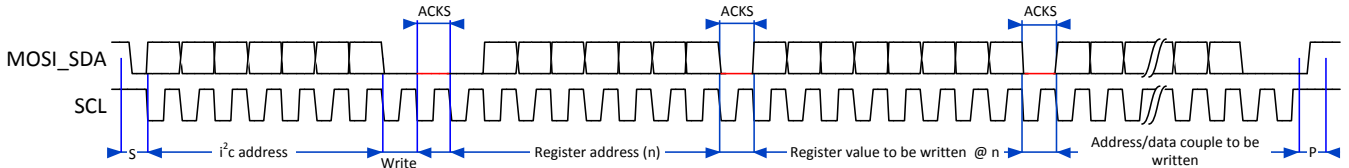
Figure 6-1: I2C write (multiple transactions)

To access registers in read mode, first address should first be send in write mode. Then a stop and a start conditions must be generated and data bytes are transferred with automatic address increment:

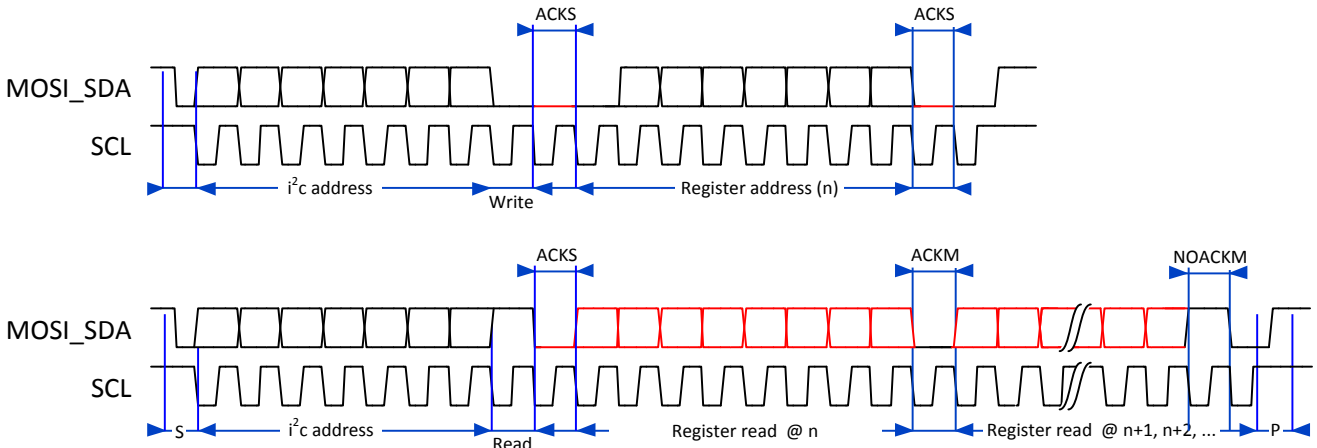
Figure 6-2: I2C read (multiple transactions)

In the case of a read transaction, it is possible to avoid stopping and starting again a new transaction by following the register address with a repeated start.

6.2. SPI INTERFACE

The SPI interface is a standard Serial to Peripheral Interface. It is compatible with two of the four standard transmission modes. The automatic selection between the two modes ([CPOL='0' and CPHA='0'] and [CPOL='1' and CPHA='1']) is determined by the value of SCL after the CS rising edge.

The SPI interface can be used in 4-wire or 3-wire. The 3-wire is selected by setting the register *reg_spi_i2c_cfg.spi_3w_en* to '1'. The pin MOSI is used as a data pin in 3-wire mode.

The SPI interface is a byte-oriented transmission interface. The first byte sent is contains the address of the register and access type of the transmission – on the first transmitted bit (reads register – '1' – or writes register – '0'). The following bytes contain register values. On read access the address read is incremented for each additional byte until the address 0x7F. When reaching this address, the devices internal address counter wraps to 0x00 and starts to read again from this address.

In case of a write transaction the protocol is based on an interleaved scheme of address and data. The first byte contains a 7-bit address and the write command (First sent bit of the first byte equal to '0'). The second byte contains data to be written to this address.

It is important to note that it is possible to send a set of write commands, followed by a multi read transaction within the same SPI transaction. Once in read mode, write accesses are not possible anymore in the same SPI transaction.

The following example shows a write of some registers followed by a check of the data.

0x00	0x05	0x01	0x03	0x06	0x02	0x80	0x00	0x00	0x00	0x00
Set hrv_period to 1/8 Hz		Set hrv_meas to 128ms		Set the system in primary cell mode		Read registers 0x00 to 0x03				

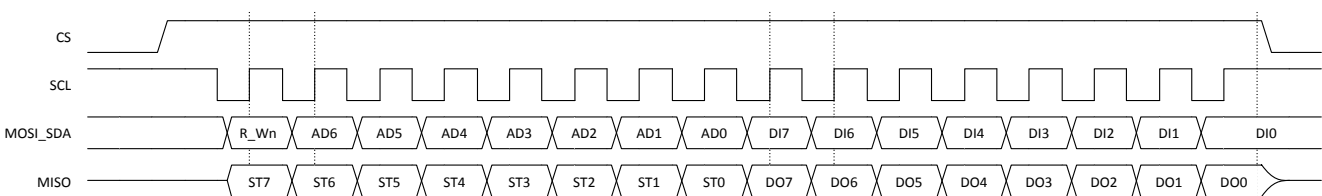
Figure 6-3 SPI transaction scheme CPOL=1, CPHA=1

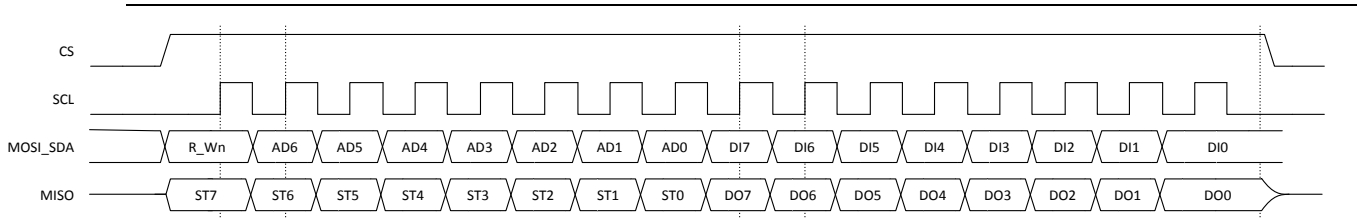
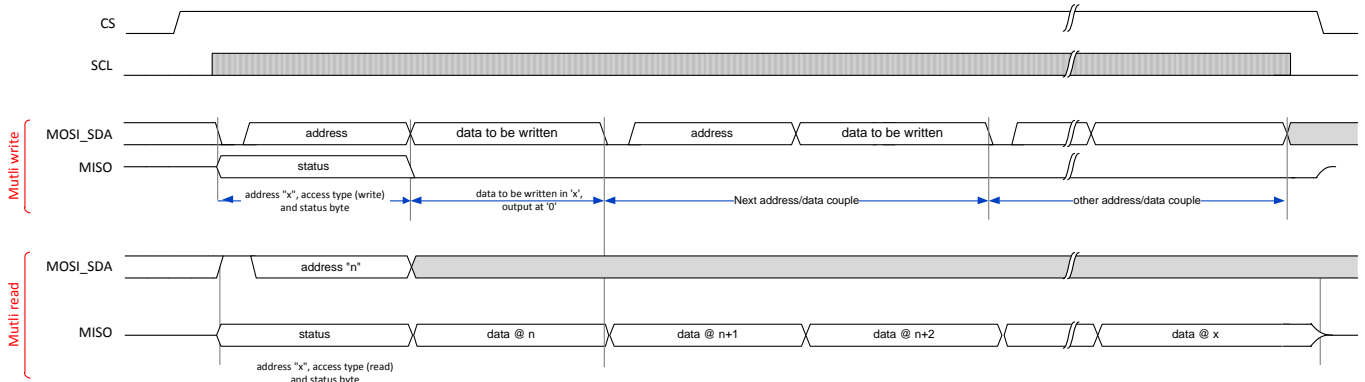
Figure 6-4 SPI transaction scheme CPOL=0, CPHA=0

Figure 6-5 Multi register access transaction

Along with the address information the SPI interface sends the status register (*reg_status* – address 0x22) as the first response byte. In the case of the 3-wire mode the protocol is identical to the I²C interface, and doesn't allow having the status byte when sending the address to the device.

Interface signals are the following:

- CS chip select, active high
- SCL clock
- MOSI_SDA data input; data input/output in 3-wire mode
- MISO data output; Hi-Z level in 3-wire mode

6.2.1. INTERFACE SELECTION

The interface selection process is done through the use of the CS pin.

At reset (at the end of the boot sequence) the default interface selection is I²C. The SPI selection is done by asserting the CS pin. After CS assertion the SPI interface is selected until the device is shut-down (V_{STS} below $V_{cs_{lo}}$).

If the CS pin is continuously asserted (through a hard connection to VSUP) the SPI interface is permanently selected. I²C is not available in this case.

Register name: <i>reg_spi_i2c_cfg</i>			Address: 0x18	Default value mapped in E ² PROM
Bits	Bit name	Type	Description	
7	<i>spi_3w_en</i>	RW	Set the SPI in its 3 wire mode (shared MOSI/MISO)	
6:0	<i>i2c_addr</i>	RW	i2c address	

Table 6-1 SPI/I²C configuration register (0x18)

6.3. E2PROM

6.3.1. ACCESSING THE E2PROM

The on-chip E²PROM contains the default working parameters of the device. The E²PROM address space is mapped into the EM8500 register map from address 0x40 (E²PROM address 0) to 0x7F ((E²PROM address 63). Some addresses are reserved (0x76 to 0x7F) and are accessible in read-only mode by the user; some contains the defaults values – as described on §8. All other addresses can be freely used.

The user can write on the E²PROM at any time. Note that no protection is built in to prevent incomplete write transaction caused by a lack of energy (STS too low). The user must ensure that the EM8500 is able to properly finish a write transaction.

Read and write accesses are performed through the serial interface. In difference to standard registers (addresses 0x00 to 0x3F), an E²PROM access requires a dead time. A read access needs a dead time between read address and the data. A write access requires a dead time after having sent the write data.

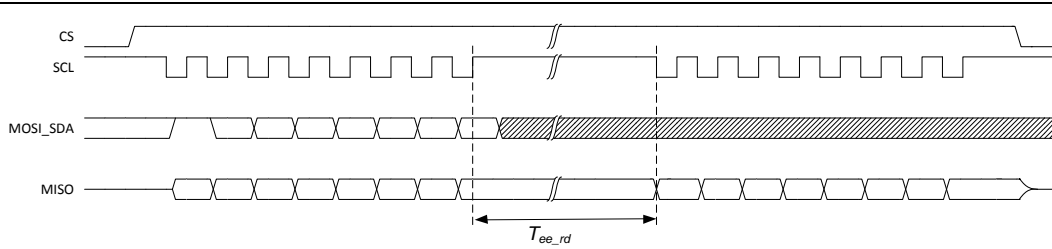
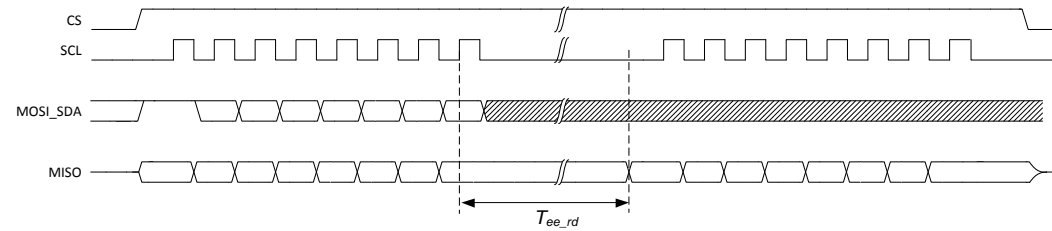
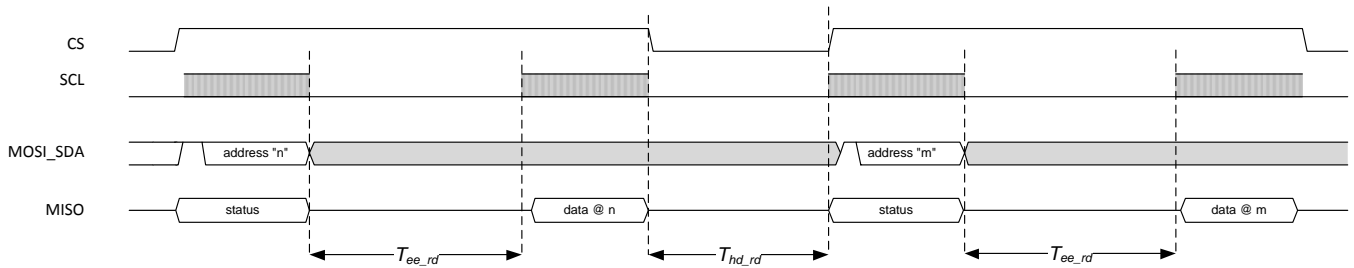
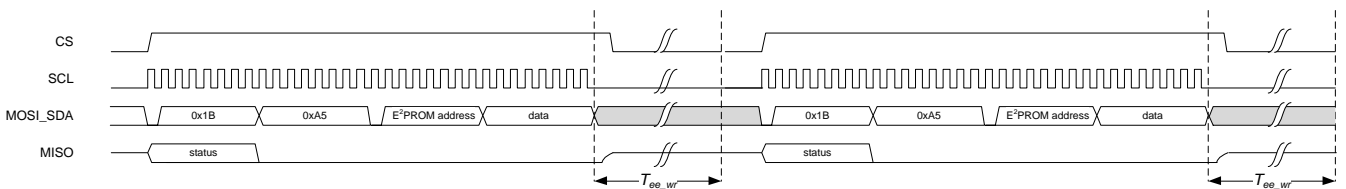
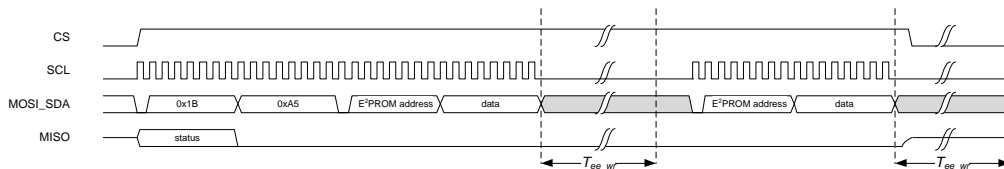
Figure 6-6 SPI transaction for reading the E²PROM (CPOL=1)

Figure 6-7 SPI transaction for reading the E²PROM (CPOL=0)

Table 6-2 SPI multiple E²PROM read transactions

Figure 6-8 Two consecutive single E²PROM write SPI transactions

Figure 6-9 SPI multi-byte transaction for writing the E²PROM

When the I²C serial interface is used only single action per transaction is allowed when accessing the E²PROM. As for an SPI transaction a dead time are necessary. Prior to a write transaction into the E²PROM it is necessary to set the *reg_protection_key* register to 0xA5.

For a write transaction, no other I²C transaction into the E²PROM address area is allowed for T_{wr_ee} after the end of the write transaction. A transaction inside this time window is ignored by the device.

In the following diagram responses from EM8500 are shown in red, data from the I²C master in black.

The following abbreviations are used:

- W Write transaction request
- R Read transaction request
- S Start an I²C transaction

- P Stop an I²C transaction
- A I²C Acknowledge
- N I²C Non Acknowledge

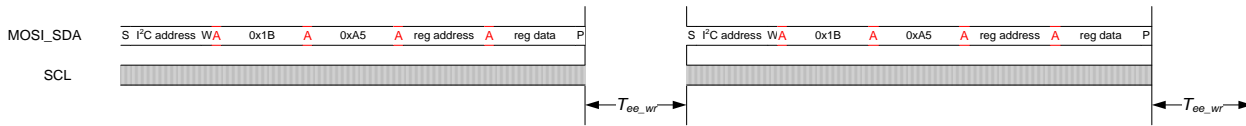

Figure 6-10 I²C transaction for writing on the E²PROM

For a read transaction a dead-time (T_{rd_ee}) has to be inserted in between the address setting transaction and the read action itself.

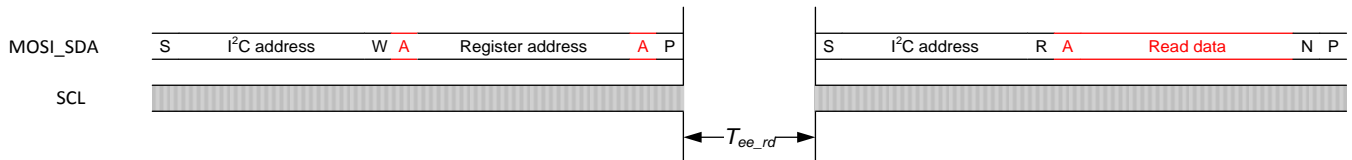

Figure 6-11 I²C transaction for reading the E²PROM

7. TYPICAL CHARACTERISTICS

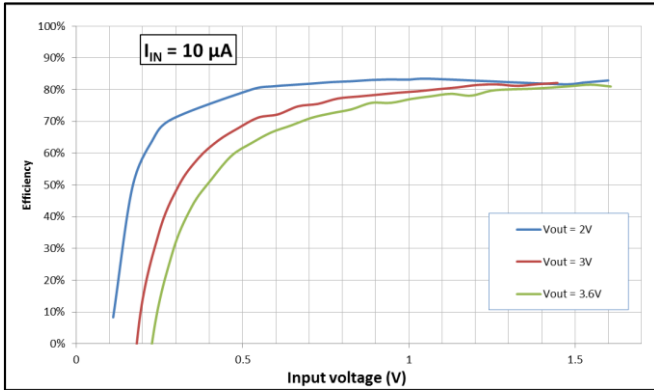

Figure 7-1 Charger Efficiency vs Input Voltage ($I_{IN} = 10\mu A$)

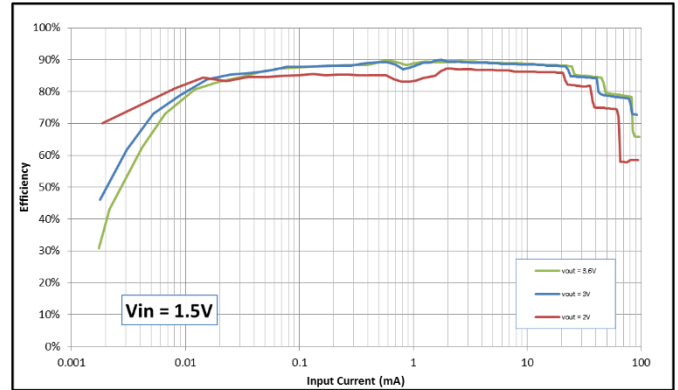

Figure 7-2 Charger Efficiency vs Input Current ($V_{IN} = 1.5V$)

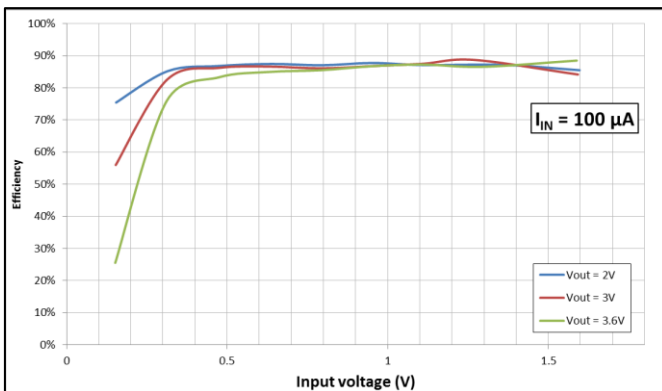

Figure 7-3 Charger Efficiency vs Input Voltage ($I_{IN} = 100\mu A$)

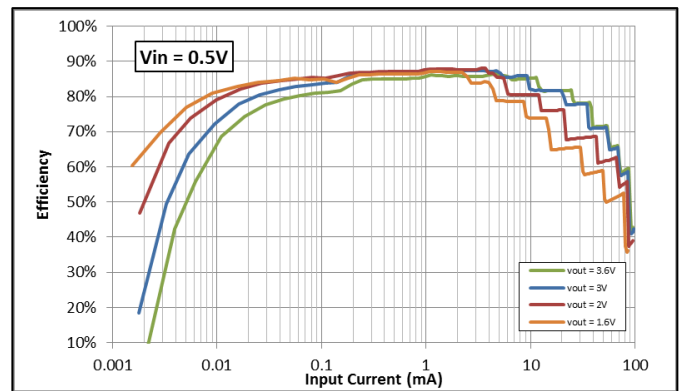

Figure 7-4 Charger Efficiency vs Input Current ($V_{IN} = 0.5V$)

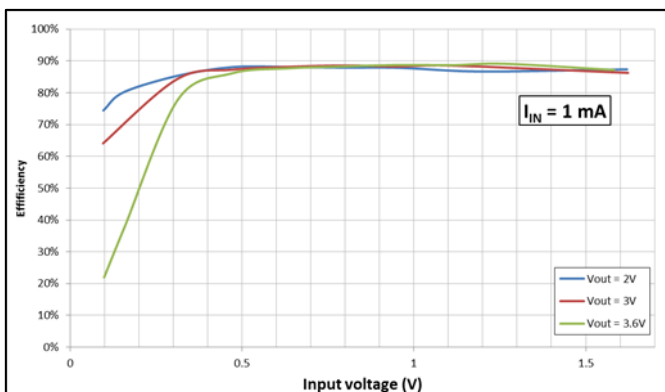

Figure 7-5 Charger Efficiency vs Input Voltage ($I_{IN} = 1\text{ mA}$)

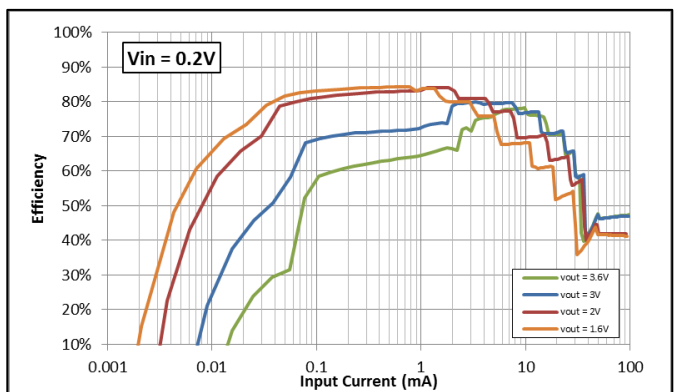

Figure 7-6 Charger Efficiency vs Input Current ($V_{IN} = 0.2V$)

Register Name	Address		Index								Reset
	Hex	Dec	7	6	5	4	3	2	1	0	Value
<i>reg_soft_res_word</i>	0x1A	26									0x00
reg_protect_key	0x1B	27									0x00
reg_lux_meter_cfg	0x1C	28	-	lux_auto_meas	lux_auto_rng	lux_manu	lux_lv(3:0)				0x00
reg_lux_meter_result	0x1D	29	-	-	-	lux_meter_busy	lux_meter_result(3:0)				0x00
reg_status	0x22	34	eeprom_data_busy	hrv_lux_busy	hrv_low	bat_low	sw_vdcdc_its_nsts	sw_its_sts	usb_on	its_protect	0x00
reg_vid_status	0x23	35	its_bat_min_hi	its_bat_min_lo	sts_bat_max_hi	sts_bat_max_lo	sts_apl_max_lo	sts_apl_max_hi	sts_bat_min_lo	sts_bat_min_hi	0x00

Table 8-2 Register summary – No E²PROM default values

Note: *Italic-underlined* register (reg_soft_res_word) is protected against accidental write action. For writing it, it is required to first write reg_protect_key to 0xE2, before writing into them within the same communication transaction – see §5.8.2

Register Name	Address		Factory Value	Index												
	Hex	Dec		7	6	5	4	3	2	1	0					
eeprom0	0x40	64	0x06	-	-	-	-	-	-	-	-	-	-	-	-	t_hrv_period(2:0)
eeprom1	0x41	65	0x06	-	-	-	-	-	-	-	-	-	-	-	-	t_hrv_meas(2:0)
eeprom2	0x42	66	0x02	-	-	-	-	-	-	-	-	-	-	-	-	t_sts_period(2:0)
eeprom3	0x43	67	0x05	-	-	-	-	-	-	-	-	-	-	-	-	t_lts_period(2:0)
eeprom4	0x44	68	0x01	-	hrv_check_vid	-	-	-	-	-	-	-	-	-	-	v_hrv_min(5:0)
eeprom5	0x45	69	0x04	-	-	-	-	-	-	-	-	-	-	-	-	hrv_check_lv(3:0)
eeprom6	0x46	70	0x00	-	-	-	-	-	-	-	-	-	-	prim_cell_connect	prim_cell	no_bat_protect
eeprom7	0x47	71	0x2A	-	-	-	-	-	-	-	-	-	-	-	-	v_bat_max_hi(5:0)
eeprom8	0x48	72	0x29	-	-	-	-	-	-	-	-	-	-	-	-	v_bat_max_lo(5:0)
eeprom9	0x49	73	0x1E	-	-	-	-	-	-	-	-	-	-	-	-	v_bat_min_hi_dis(5:0)
eeprom10	0x4A	74	0x1E	-	-	-	-	-	-	-	-	-	-	-	-	v_bat_min_hi_con(5:0)
eeprom11	0x4B	75	0x1D	-	-	-	-	-	-	-	-	-	-	-	-	v_bat_min_lo(5:0)
eeprom12	0x4C	76	0x25	-	-	-	-	-	-	-	-	-	-	-	-	v_apl_max_hi(5:0)
eeprom13	0x4D	77	0x21	-	-	-	-	-	-	-	-	-	-	-	-	v_apl_max_lo(5:0)
eeprom14	0x4E	78	0xCF	vsup_tied_low	-	-	-	-	-	-	-	-	-	-	-	v_ulp_ldo(2:0)
eeprom15	0x4F	79	0x7E	usb_ldo_frc_dis	dis_vaux_gnd2_hrv_low	dis_vaux_gnd1_hrv_low	dis_vaux_gnd0_hrv_low	dis_vaux2_hrv_low	dis_vaux1_hrv_low	dis_vaux0_hrv_low	dis_vaux0_hrv_low	dis_vaux0_hrv_low	dis_vaux0_hrv_low	dis_vaux0_hrv_low	dis_vaux0_hrv_low	dis_vaux0_hrv_low
eeprom16	0x50	80	0x15	-	-	-	-	-	-	-	-	-	-	-	-	vaux1_cfg(1:0)
eeprom17	0x51	81	0x01	-	-	-	-	-	-	-	-	-	-	-	-	vaux_gnd2_cfg
eeprom18	0x52	82	0x06	-	-	-	-	-	-	-	-	-	-	-	-	vaux_gnd1_cfg
eeprom19	0x53	83	0x65	sda_slopectrl	wake_up_deb_en	wake_up_deb_en	wake_up_deb_en	wake_up_deb_en	wake_up_deb_en	wake_up_deb_en	wake_up_deb_en	wake_up_deb_en	wake_up_deb_en	wake_up_deb_en	wake_up_deb_en	vaux_gnd0_cfg
eeprom20	0x54	84	0x99	-	-	-	-	-	-	-	-	-	-	-	-	mpp_ratio(3:0)
eeprom21	0x55	85	0x3A	-	-	-	-	-	-	-	-	-	-	-	-	usb_crt_src_sel(1:0)
eeprom22	0x56	86	0x00	-	-	-	-	-	-	-	-	-	-	-	-	usb_frc_hrv_low_hiz
eeprom23	0x57	87	0x67	-	-	-	-	-	-	-	-	-	-	-	-	usb_frc_bat_low_hiz
eeprom24	0x58	88	0x77	spl_3w_en	-	-	-	-	-	-	-	-	-	-	-	usb_frc_bat_low_hiz
eeprom25	0x59	89	0x00	frc_prim_dcoc_dis	vaux_gnd2_en	vaux_gnd1_en	vaux_gnd0_en	vaux2_en	vaux1_en	vaux0_en	vaux0_en	vaux0_en	vaux0_en	vaux0_en	vaux0_en	sleep_vsop

Note: All E²PROM is protected against accidental write action. For writing into the E²PROM it is required to first write into reg_protect_key the value 0xA5, before writing into it within the same communication transaction see §5.8.2

Table 8-3 E²PROM default values memory mapping

9. TYPICAL APPLICATIONS

9.1. SAMPLE SCHEMATICS

9.1.1. SOLAR CELL ASSISTED SYSTEM

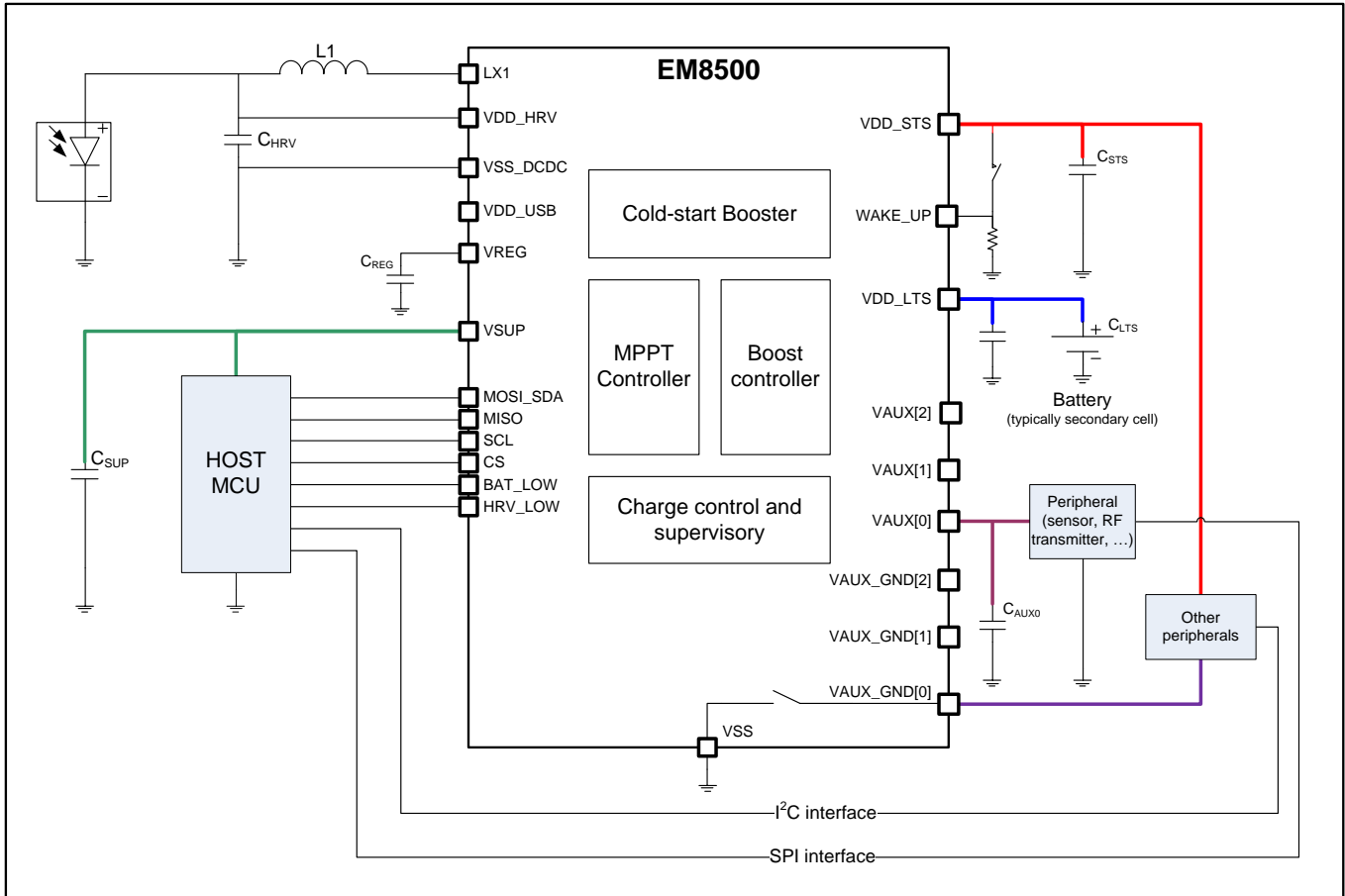
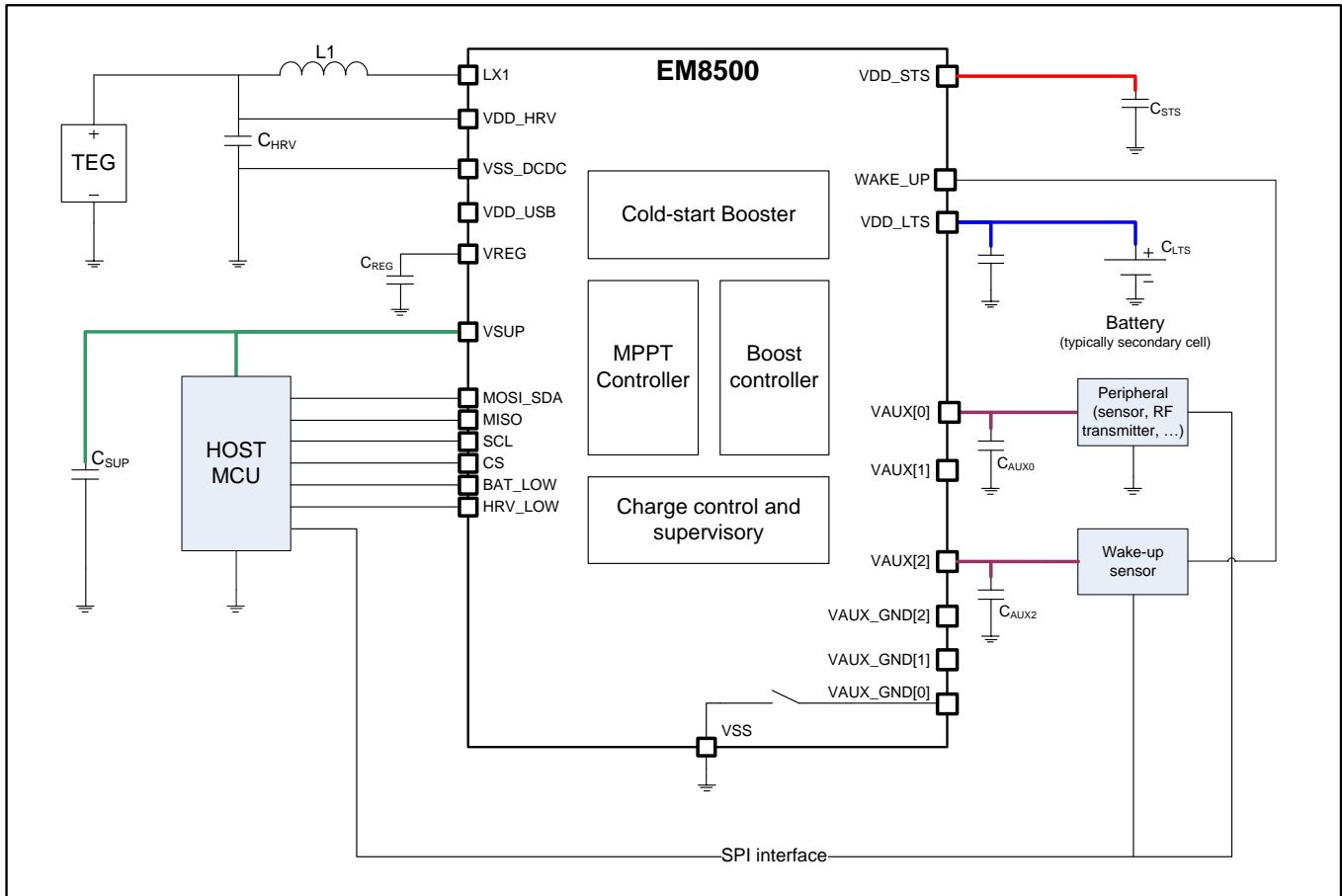

Figure 9-1 Example of Application with a Solar Cell Harvester

Component	Symbol	Value
Booster inductor	L1	47 μ H
Harvester capacitor	C _{HRV}	4.7 μ F
STS capacitor	C _{STS}	47 μ F
Regulator capacitor	C _{REG}	470 nF
Main supply output capacitor	C _{SUP}	1 μ F
Auxiliary (2) supply output capacitor	C _{AUX2}	1 μ F

Table 9-1 Component list for solar cell application

9.1.2. TERMO-ELECTRICAL GENERATOR (TEG) ASSISTED SYSTEM

Figure 9-2 Example of Application with a Thermo-electrical Generator (TEG) Harvester

Component	Symbol	Value
Booster inductor	L1	47µH
Harvester capacitor	C _{HRV}	4.7µF
STS capacitor	C _{STS}	47µF
Regulator capacitor	C _{REG}	470 nF
Main supply output capacitor	C _{SUP}	1 µF
Auxiliary (0) supply output capacitor	C _{AUX0}	1 µF
Auxiliary (2) supply output capacitor	C _{AUX2}	1 µF

Table 9-2 Component list for TEG application
9.2. INDUCTOR SELECTION

The boost DCDC converter requires a properly selected inductor to obtain highest efficiency. Apart from the typical value of the inductor (47 µH ± 20%), coil saturation current and the internal resistivity need to be considered.

The saturation current should be at least 30% higher than the maximum peak current. The internal resistivity should be as low as possible – a typical value of 0.65 Ω is suitable.

9.2.1. REFERENCE INDUCTORS

Manufacturer	Size			RDC		Part number	Comments
	Length	Width	Thickness	Typ	Max		
TDK	4mm	4mm	2.4mm	560mΩ	644mΩ	VLCF4024T-470MR44-2	High efficiency performances
TDK	3mm	3mm	1.2mm	1.25Ω	1.5Ω	VLS3012ET-470M	
TAIYO YUDEN	1.6mm	0.8mm	0.8mm	2.5Ω		CBMF1608T470K	Up to 500uW and Vhrv 1V max

Table 9-3 List of reference inductors

9.3. CAPACITOR SELECTION

The selection of the capacitor is strongly linked to the hysteresis value set in the configuration registers. Please refer to the application notes for capacitors values for different system applications scenarios.

10. ORDERING INFORMATION

Part Nb	Package form	Delivery form
EM8500-A001-LF24B+	QFN24 4x4 mm	Tape & Reel

Table 10-1 Ordering Information

For other delivery format please contact EM Microelectronics representative.

11. PACKAGE INFORMATION

11.1. QFN24 4X4 PACKAGE

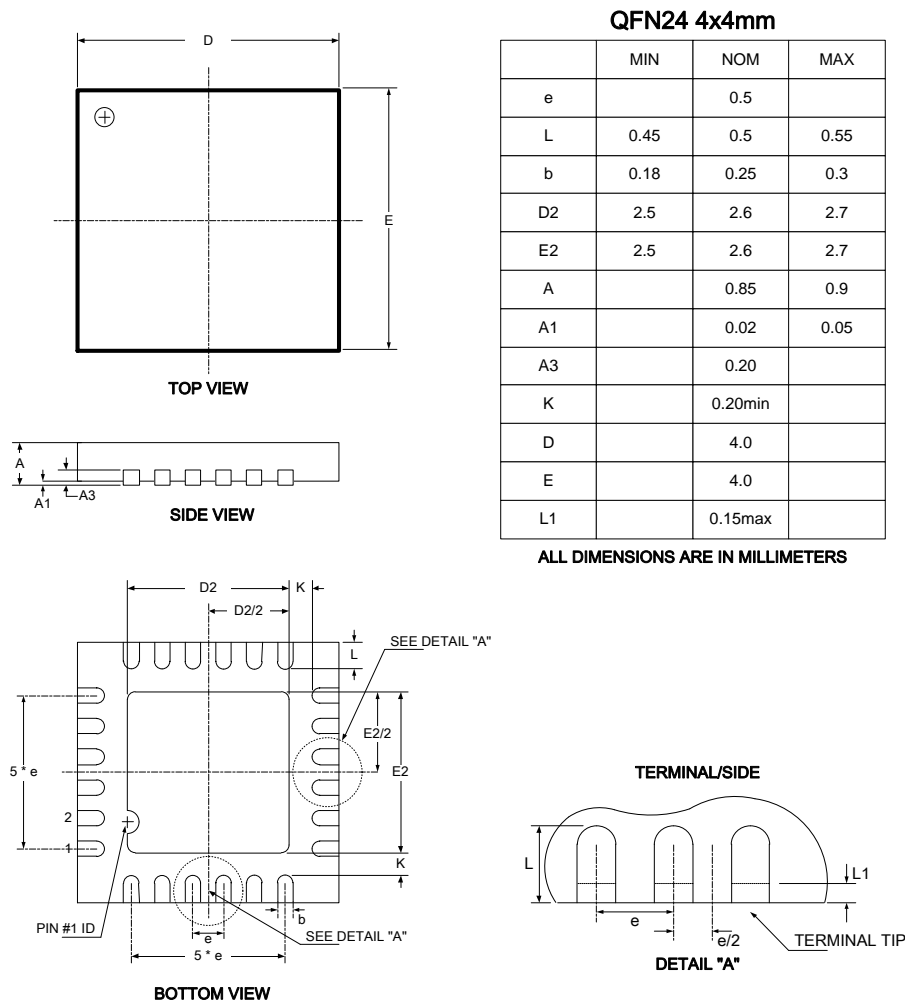

Figure 11-1 QFN24 Mechanical Information

11.1.1. PACKAGE MARKING

This section reports the package marking for EM8500. Additional marking letters and numbers are used for lot traceability.

8	5	0	0	0
0	1			



EM Microelectronic-Marín SA ("EM") makes no warranties for the use of EM products, other than those expressly contained in EM's applicable General Terms of Sale, located at <http://www.emmicroelectronic.com>. EM assumes no responsibility for any errors which may have crept into this document, reserves the right to change devices or specifications detailed herein at any time without notice, and does not make any commitment to update the information contained herein.



No licenses to patents or other intellectual property rights of EM are granted in connection with the sale of EM products, neither expressly nor implicitly.

In respect of the intended use of EM products by customer, customer is solely responsible for observing existing patents and other intellectual property rights of third parties and for obtaining, as the case may be, the necessary licenses.







Important note: The use of EM products as components in medical devices and/or medical applications, including but not limited to, safety and life supporting systems, where malfunction of such EM products might result in damage to and/or injury or death of persons is expressly prohibited, as EM products are neither destined nor qualified for use as components in such medical devices and/or medical applications. The prohibited use of EM products in such medical devices and/or medical applications is exclusively at the risk of the customer.

Looking for pricing, stock, or lifecycle information?

Click below to explore more details on WIN SOURCE:

-  [View EM8500-A001-LF24B+ on WIN SOURCE](#)
-  [EM Microelectronic Information](#)

Optimize Your Supply Chain with WIN SOURCE Solutions

-  Global Sourcing Solution
-  Obsolete Management
-  Cost Control Management
-  Shortage Management
-  Alternative Solution
-  Excess Inventory Management