



THE DATASHEET OF MRF158



The Broadband RF TMOS[®] Line 2W, 500MHz, 28V

Rev. V1

Designed for wideband large signal amplifier and oscillator applications to 500MHz

N-Channel enhancement mode

- Guaranteed 28 volt, 500 MHz performance
Output power = 2.0 watts
Minimum gain = 16 dB (Min.)
Efficiency = 55% (Typ.)
- Facilitates manual gain control, ALC and modulation techniques
- 100% tested for load mismatch at all phase angles with 30:1 VSWR
- Excellent thermal stability ideally suited for Class A operation

Product Image

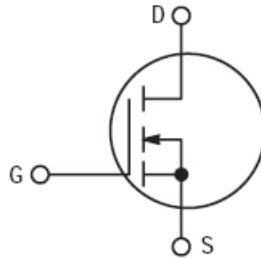
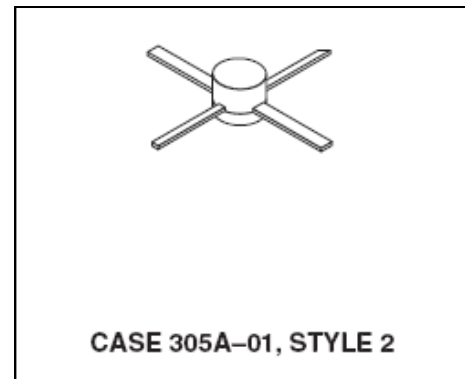

MAXIMUM RATINGS

Rating	Symbol	Value	Unit
Drain-Source Voltage	V_{DSS}	65	Vdc
Drain-Gate Voltage ($R_{GS} = 1.0 \text{ M}\Omega$)	V_{DGR}	65	Vdc
Gate-Source Voltage	V_{GS}	± 20	Vdc
Drain Current — Continuous	I_D	0.5	Adc
Total Device Dissipation @ $T_C = 25^\circ\text{C}$ Derate above 25°C	P_D	8.0 45	Watts mW/ $^\circ\text{C}$
Storage Temperature Range	T_{stg}	-65 to +150	$^\circ\text{C}$
Operating Junction Temperature	T_J	200	$^\circ\text{C}$

THERMAL CHARACTERISTICS

Characteristic	Symbol	Max	Unit
Thermal Resistance, Junction to Case	$R_{\theta JC}$	13.2	$^\circ\text{C}/\text{W}$

NOTE — **CAUTION** — MOS devices are susceptible to damage from electrostatic charge. Reasonable precautions in handling and packaging MOS devices should be observed.

The Broadband RF TMOS® Line
2W, 500MHz, 28V

Rev. V1

ELECTRICAL CHARACTERISTICS ($T_C = 25^\circ\text{C}$ unless otherwise noted.)

Characteristic	Symbol	Min	Typ	Max	Unit
----------------	--------	-----	-----	-----	------

OFF CHARACTERISTICS

Drain–Source Breakdown Voltage ($V_{GS} = 0$, $I_D = 1.0$ mA)	$V_{(BR)DSS}$	65	—	—	Vdc
Zero Gate Voltage Drain Current ($V_{DS} = 28$ V, $V_{GS} = 0$)	I_{DSS}	—	—	0.5	mAdc
Gate–Source Leakage Current ($V_{GS} = 20$ V, $V_{DS} = 0$)	I_{GSS}	—	—	1.0	μAdc

ON CHARACTERISTICS

Gate Threshold Voltage ($I_D = 10$ mA, $V_{DS} = 10$ V)	$V_{GS(th)}$	2.0	4.0	5.0	Vdc
Forward Transconductance ($V_{DS} = 10$ V, $I_D = 100$ mA)	g_{fs}	80	110	—	mmhos

DYNAMIC CHARACTERISTICS

Input Capacitance ($V_{DS} = 28$ V, $V_{GS} = 0$, $f = 1.0$ MHz)	C_{iss}	—	3.0	—	pF
Output Capacitance ($V_{DS} = 28$ V, $V_{GS} = 0$, $f = 1.0$ MHz)	C_{oss}	—	4.0	—	pF
Reverse Transfer Capacitance ($V_{DS} = 28$ V, $V_{GS} = 0$, $f = 1.0$ MHz)	C_{rss}	—	0.45	—	pF

FUNCTIONAL CHARACTERISTICS (Figure 1)

Common Source Power Gain ($V_{DD} = 28$ Vdc, $P_{out} = 2.0$ W, $f = 500$ MHz, $I_{DQ} = 25$ mA)	G_{ps}	16	18	—	dB
Drain Efficiency (Figure 1) ($V_{DD} = 28$ Vdc, $P_{out} = 2.0$ W, $f = 500$ MHz, $I_{DQ} = 25$ mA)	η	50	55	—	%
Electrical Ruggedness (Figure 1) ($V_{DD} = 28$ Vdc, $P_{out} = 2.0$ W, $f = 500$ MHz, $I_{DQ} = 25$ mA, VSWR 30:1 at all Phase Angles)	ψ	No Degradation in Output Power			
Series Equivalent Input Impedance ($V_{DD} = 28$ V, $P_{out} = 2.0$ W, $f = 500$ MHz, $I_{DQ} = 25$ mA)	Z_{in}	—	$5.9 - j19.4$	—	Ohms
Series Equivalent Output Impedance ($V_{DD} = 28$ V, $P_{out} = 2.0$ W, $f = 500$ MHz, $I_{DQ} = 25$ mA)	Z_{out}	—	$14.5 - j29$	—	Ohms

The Broadband RF TMOS[®] Line 2W, 500MHz, 28V

Rev. V1

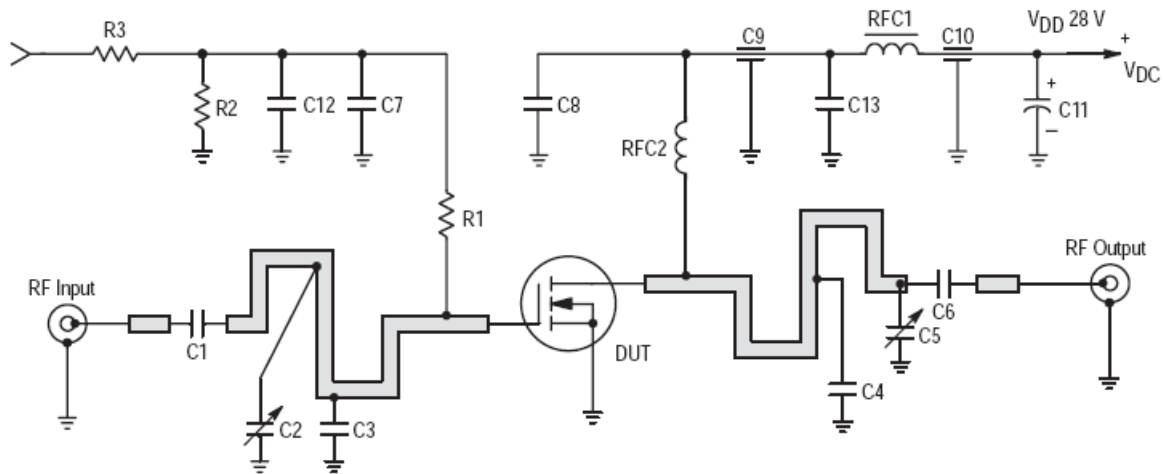

C1, C6, C12	270 pF, Chip Capacitors
C2, C5	1 – 10 pF, Johanson Trimmer Capacitors
C3	30 pF, 100 mil ATC Chip Capacitor
C4	3.9 pF, 100 mil ATC Chip Capacitor
C7, C8	0.1 μ F, Blue Capacitors
C9, C10	680 pF, Feed Through Capacitors
C11	50 μ F, 50 V Electrolytic Capacitor
C13	240 pF, 100 mil ATC Chip Capacitor

R1	150 Ω , 1/2 Watt
R2	10 k Ω , 1/2 Watt
R3	1 k Ω , 1/2 Watt
RFC1	Ferroxcube VK200–19/4B
RFC2	8 Turns, #20 AWG, Enameled, ID 110 mils

Board Material — 0.062", Teflon[®] Fiberglass, 1 oz.,
Copper clad both sides, $\epsilon_r = 2.55$

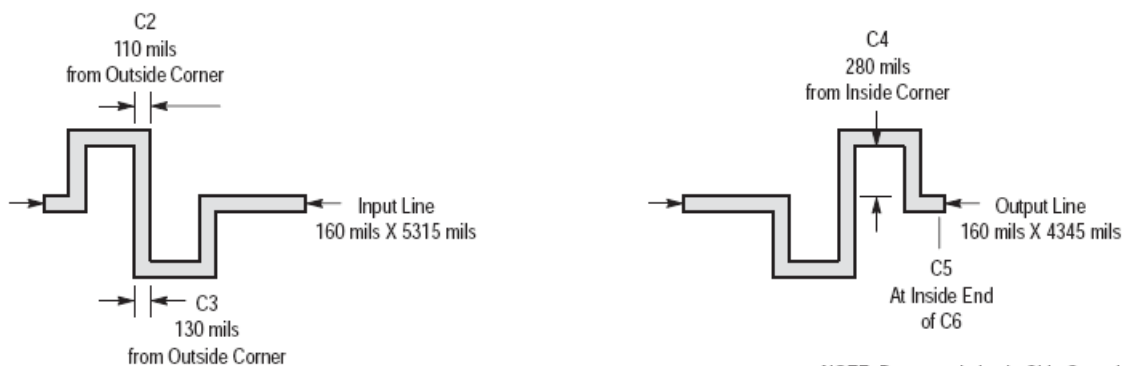

NOTE: Due to variation in Chip Capacitor values and board material, these are approximate positions.

Figure 1. MRF158 500 MHz Test Circuit

MRF158



The Broadband RF TMOS® Line
2W, 500MHz, 28V

Rev. V1

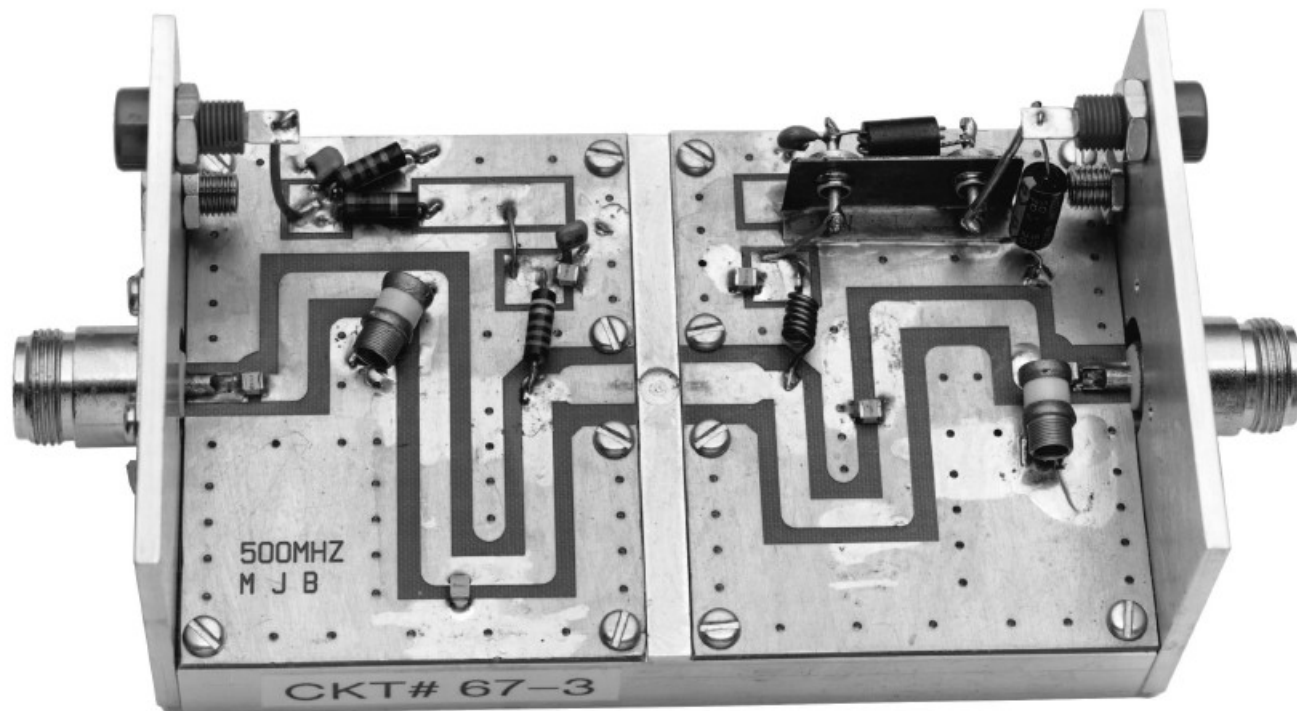

Figure 2. MRF158 Broadband Test Fixture

TYPICAL CHARACTERISTICS

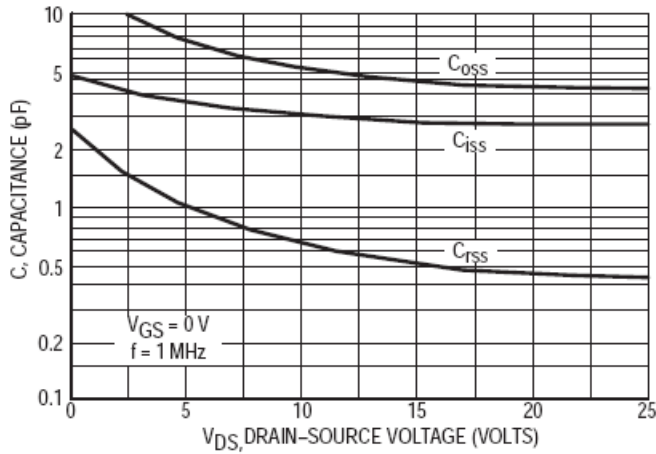

Figure 3. Capacitance versus Drain-Source Voltage

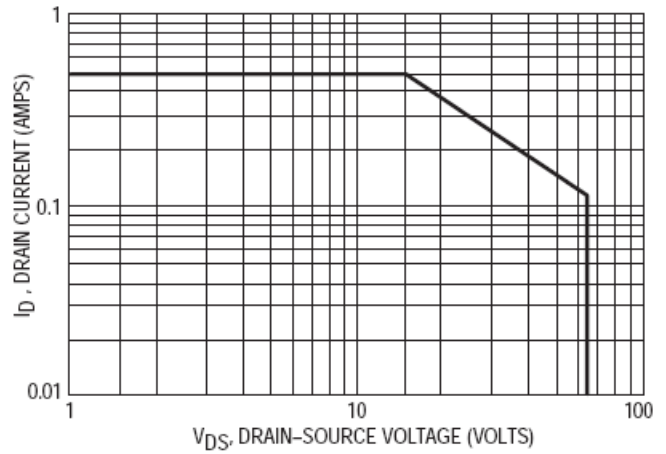

Figure 4. DC Safe Operating Area

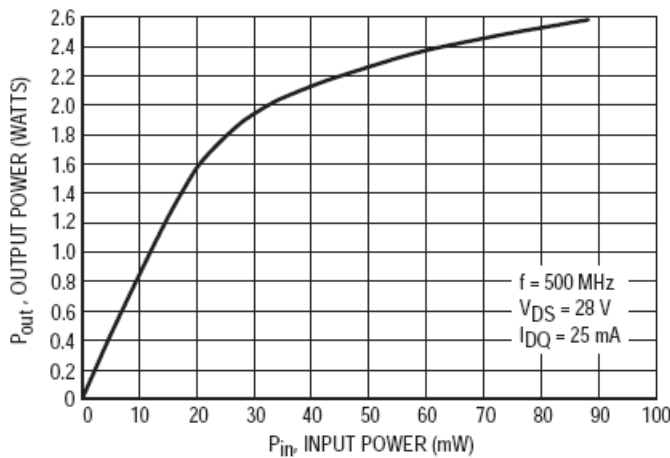

Figure 5. Output Power versus Input Power

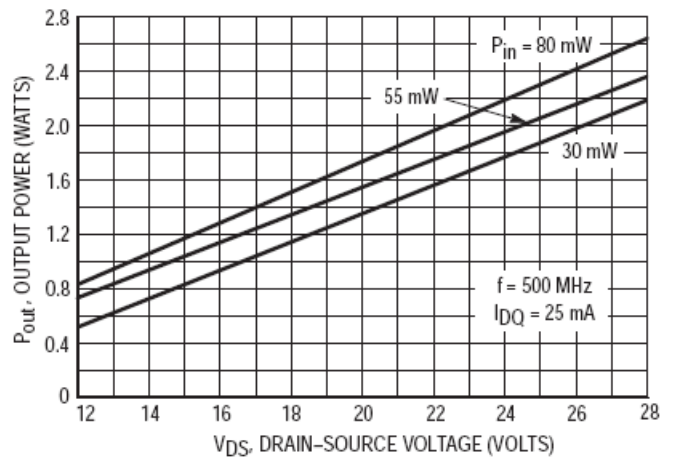

Figure 6. Output Power versus Voltage

The Broadband RF TMOS® Line 2W, 500MHz, 28V

Rev. V1

Table 1. Common Source S-Parameters ($V_{DS} = 13\text{ V}$, $I_D = 100\text{ mA}$)

f MHz	S ₁₁		S ₂₁		S ₁₂		S ₂₂	
	S ₁₁	∠	S ₂₁	∠	S ₁₂	∠	S ₂₂	∠
5	1.000	-2	9.45	179	0.000	89	0.965	-1
10	0.997	-4	9.45	177	0.005	92	0.969	-3
15	0.999	-5	9.50	176	0.007	86	0.962	-5
20	0.997	-7	9.45	174	0.009	91	0.958	-6
25	0.997	-9	9.44	173	0.012	88	0.958	-7
30	0.996	-10	9.40	172	0.014	82	0.960	-8
35	0.994	-12	9.38	170	0.016	78	0.956	-10
40	0.993	-14	9.35	169	0.016	77	0.958	-11
45	0.990	-15	9.34	167	0.020	79	0.957	-12
50	0.988	-17	9.29	166	0.021	76	0.957	-14
55	0.985	-19	9.25	165	0.023	77	0.955	-15
60	0.983	-21	9.26	163	0.026	75	0.952	-17
65	0.980	-22	9.19	162	0.028	74	0.947	-18
70	0.977	-24	9.15	160	0.029	74	0.943	-20
75	0.973	-25	9.11	159	0.031	74	0.942	-21
80	0.970	-27	9.04	158	0.034	70	0.935	-22
85	0.967	-29	8.98	157	0.035	71	0.932	-24
90	0.963	-30	8.91	155	0.037	67	0.929	-25
95	0.961	-32	8.90	154	0.039	68	0.924	-26
100	0.957	-33	8.81	153	0.040	67	0.917	-27
105	0.953	-35	8.77	151	0.041	64	0.916	-28
109	0.950	-36	8.69	150	0.042	65	0.914	-30
114	0.943	-38	8.62	149	0.045	63	0.906	-31
119	0.940	-40	8.56	148	0.045	62	0.907	-32
124	0.933	-41	8.49	146	0.049	61	0.901	-33
129	0.933	-43	8.46	145	0.049	60	0.901	-35
134	0.923	-44	8.37	144	0.052	59	0.896	-36
139	0.921	-45	8.29	143	0.052	58	0.890	-37
144	0.917	-47	8.22	142	0.055	57	0.885	-39
149	0.913	-48	8.16	140	0.055	55	0.878	-40

The Broadband RF TMOS® Line 2W, 500MHz, 28V

Rev. V1

Table 1. Common Source S-Parameters ($V_{DS} = 13\text{ V}$, $I_D = 100\text{ mA}$)

f MHz	S ₁₁		S ₂₁		S ₁₂		S ₂₂	
	S ₁₁	∠	S ₂₁	∠	S ₁₂	∠	S ₂₂	∠
154	0.911	-50	8.11	140	0.057	53	0.874	-41
159	0.905	-51	8.02	138	0.059	54	0.868	-42
164	0.902	-52	7.94	137	0.059	53	0.863	-43
169	0.896	-54	7.87	136	0.062	52	0.856	-44
174	0.893	-55	7.79	135	0.063	50	0.851	-45
179	0.890	-56	7.71	134	0.062	50	0.846	-46
184	0.882	-58	7.64	133	0.065	48	0.845	-47
189	0.881	-59	7.59	132	0.065	47	0.840	-48
194	0.874	-60	7.53	131	0.066	47	0.834	-49
199	0.868	-61	7.43	130	0.067	47	0.828	-50
204	0.864	-62	7.36	129	0.068	46	0.829	-51
209	0.861	-63	7.31	128	0.070	45	0.824	-52
214	0.856	-65	7.24	127	0.070	44	0.820	-53
219	0.853	-66	7.17	126	0.070	43	0.813	-54
224	0.848	-67	7.10	125	0.072	41	0.806	-55
229	0.847	-68	7.02	124	0.074	41	0.803	-56
234	0.841	-69	6.94	124	0.075	40	0.800	-57
239	0.839	-70	6.92	122	0.074	39	0.789	-58
244	0.832	-71	6.80	122	0.076	40	0.783	-59
249	0.828	-72	6.73	121	0.077	38	0.780	-60
254	0.825	-73	6.68	120	0.077	39	0.778	-60
259	0.820	-74	6.60	119	0.078	36	0.772	-61
264	0.816	-75	6.54	118	0.078	35	0.769	-62
269	0.813	-76	6.48	117	0.078	36	0.765	-63
274	0.810	-77	6.42	117	0.079	34	0.765	-64
279	0.806	-78	6.34	116	0.080	35	0.762	-64
284	0.799	-79	6.29	115	0.080	34	0.757	-65
289	0.800	-80	6.23	114	0.081	31	0.756	-66
294	0.795	-81	6.18	113	0.081	33	0.753	-67
299	0.789	-82	6.12	113	0.084	31	0.750	-67
304	0.791	-83	6.07	112	0.082	31	0.742	-68
308	0.790	-84	5.99	111	0.084	30	0.742	-69
313	0.787	-85	5.95	110	0.084	29	0.737	-70

The Broadband RF TMOS® Line 2W, 500MHz, 28V

Rev. V1

Table 1. Common Source S-Parameters ($V_{DS} = 13\text{ V}$, $I_D = 100\text{ mA}$) (continued)

f MHz	S ₁₁		S ₂₁		S ₁₂		S ₂₂	
	S ₁₁	∠	S ₂₁	∠	S ₁₂	∠	S ₂₂	∠
318	0.784	-85	5.88	109	0.083	30	0.729	-70
323	0.779	-86	5.80	109	0.084	28	0.726	-71
328	0.778	-87	5.77	108	0.085	27	0.723	-72
333	0.773	-88	5.69	107	0.085	28	0.720	-72
338	0.771	-89	5.64	107	0.084	26	0.716	-73
343	0.766	-89	5.60	106	0.086	25	0.716	-74
348	0.766	-90	5.55	106	0.086	25	0.712	-74
353	0.763	-91	5.50	105	0.086	24	0.708	-75
358	0.761	-92	5.43	104	0.086	24	0.708	-75
363	0.761	-93	5.41	104	0.086	24	0.706	-76
368	0.755	-94	5.35	103	0.086	23	0.702	-77
373	0.753	-94	5.29	102	0.087	23	0.704	-77
378	0.752	-95	5.25	101	0.086	23	0.700	-78
383	0.750	-96	5.20	101	0.087	22	0.697	-79
388	0.747	-96	5.15	100	0.089	21	0.692	-79
393	0.742	-97	5.08	100	0.087	21	0.693	-80
398	0.741	-98	5.04	99	0.088	20	0.689	-81
403	0.743	-98	5.01	98	0.088	20	0.684	-81
408	0.740	-99	4.97	98	0.088	19	0.682	-81
413	0.734	-100	4.90	97	0.089	19	0.682	-82
418	0.738	-100	4.87	97	0.088	18	0.677	-83
423	0.733	-101	4.82	96	0.089	18	0.676	-83
428	0.735	-102	4.80	96	0.089	17	0.674	-84
433	0.731	-102	4.74	95	0.088	16	0.672	-84
438	0.732	-103	4.70	94	0.088	17	0.673	-85
443	0.728	-104	4.67	94	0.089	16	0.670	-85
448	0.729	-105	4.64	93	0.090	16	0.671	-86
453	0.727	-105	4.59	93	0.088	16	0.668	-86
458	0.723	-105	4.56	92	0.089	15	0.668	-87
463	0.721	-106	4.50	91	0.088	15	0.668	-87
468	0.720	-107	4.46	91	0.088	15	0.665	-87
473	0.719	-107	4.42	90	0.089	13	0.662	-88
478	0.717	-107	4.38	90	0.089	13	0.662	-89
483	0.717	-108	4.35	89	0.088	13	0.658	-89

The Broadband RF TMOS® Line 2W, 500MHz, 28V

Rev. V1

Table 1. Common Source S-Parameters ($V_{DS} = 13\text{ V}$, $I_D = 100\text{ mA}$) (continued)

f MHz	S ₁₁		S ₂₁		S ₁₂		S ₂₂	
	S ₁₁	∠	S ₂₁	∠	S ₁₂	∠	S ₂₂	∠
488	0.715	-109	4.32	89	0.088	13	0.660	-89
493	0.714	-109	4.28	88	0.090	13	0.655	-90
498	0.714	-110	4.25	88	0.090	12	0.655	-91
503	0.713	-110	4.22	87	0.089	12	0.652	-91
507	0.712	-111	4.17	87	0.090	11	0.650	-91
512	0.711	-111	4.15	86	0.089	11	0.649	-92
517	0.706	-112	4.11	86	0.090	11	0.650	-92
522	0.705	-112	4.07	85	0.089	10	0.650	-93
527	0.706	-113	4.07	85	0.089	10	0.648	-93
532	0.705	-113	4.02	84	0.088	10	0.649	-93
537	0.704	-114	4.00	84	0.088	9	0.645	-94
542	0.704	-114	3.95	83	0.089	9	0.646	-94
547	0.704	-115	3.93	82	0.087	10	0.646	-95
552	0.704	-116	3.90	82	0.090	8	0.645	-95
557	0.702	-116	3.87	82	0.089	8	0.646	-96
562	0.699	-117	3.83	81	0.088	8	0.646	-96
567	0.699	-117	3.80	81	0.089	8	0.641	-96
572	0.700	-117	3.76	80	0.088	7	0.640	-97
577	0.699	-118	3.74	80	0.087	7	0.640	-97
582	0.698	-118	3.70	80	0.088	7	0.641	-98
587	0.699	-118	3.69	79	0.087	7	0.637	-98
592	0.697	-119	3.67	79	0.088	6	0.638	-98
597	0.698	-119	3.64	78	0.088	6	0.633	-99
602	0.698	-119	3.62	78	0.087	6	0.638	-99
607	0.695	-120	3.58	77	0.087	6	0.637	-99
612	0.696	-120	3.57	77	0.087	6	0.637	-100
617	0.694	-121	3.54	76	0.086	5	0.636	-100
622	0.695	-121	3.52	76	0.087	5	0.635	-100
627	0.692	-121	3.48	75	0.088	5	0.637	-101
632	0.691	-122	3.46	75	0.085	4	0.634	-101
637	0.691	-122	3.44	74	0.087	4	0.641	-102
642	0.689	-123	3.41	74	0.087	3	0.637	-102
647	0.687	-123	3.38	74	0.087	3	0.634	-103
652	0.689	-124	3.36	73	0.085	3	0.636	-103

The Broadband RF TMOS® Line 2W, 500MHz, 28V

Rev. V1

Table 1. Common Source S-Parameters ($V_{DS} = 13\text{ V}$, $I_D = 100\text{ mA}$) (continued)

f MHz	S ₁₁		S ₂₁		S ₁₂		S ₂₂	
	S ₁₁	φ	S ₂₁	φ	S ₁₂	φ	S ₂₂	φ
657	0.686	-124	3.34	73	0.086	1	0.635	-103
662	0.688	-125	3.30	72	0.086	3	0.634	-104
667	0.689	-125	3.28	72	0.086	2	0.634	-104
672	0.693	-125	3.27	72	0.086	2	0.631	-104
677	0.687	-126	3.24	71	0.086	1	0.632	-104
682	0.689	-126	3.22	71	0.083	1	0.629	-105
687	0.687	-126	3.20	70	0.083	1	0.630	-105
692	0.686	-127	3.17	70	0.083	1	0.630	-105
697	0.690	-127	3.16	70	0.083	0	0.630	-106
702	0.687	-127	3.14	69	0.084	0	0.627	-106
706	0.688	-128	3.12	69	0.083	1	0.630	-106
711	0.685	-128	3.10	68	0.083	0	0.632	-107
716	0.686	-128	3.08	68	0.085	0	0.636	-107
721	0.688	-128	3.08	68	0.084	-1	0.634	-107
726	0.685	-129	3.05	67	0.083	0	0.634	-108
731	0.685	-130	3.02	67	0.083	-1	0.634	-108
736	0.684	-130	3.01	66	0.083	-1	0.635	-108
741	0.680	-130	2.98	66	0.082	-1	0.631	-109
746	0.681	-130	2.97	65	0.083	-2	0.636	-109
751	0.682	-131	2.96	65	0.082	-2	0.631	-110
756	0.683	-131	2.93	65	0.082	-2	0.632	-109
761	0.681	-132	2.90	64	0.082	-1	0.630	-110
766	0.683	-132	2.89	64	0.083	-3	0.632	-110
771	0.684	-132	2.87	64	0.082	-3	0.631	-110
776	0.682	-133	2.85	63	0.081	-4	0.628	-111
781	0.684	-133	2.85	63	0.080	-3	0.630	-111
786	0.686	-133	2.83	63	0.079	-4	0.629	-111
791	0.684	-134	2.81	62	0.080	-3	0.632	-112
796	0.685	-134	2.79	62	0.080	-4	0.631	-112
801	0.683	-134	2.77	62	0.079	-4	0.634	-112
806	0.685	-134	2.75	61	0.079	-2	0.632	-112
811	0.683	-135	2.75	61	0.078	-4	0.635	-113
816	0.684	-135	2.73	60	0.079	-4	0.637	-113
821	0.683	-135	2.70	60	0.077	-3	0.633	-113
826	0.682	-135	2.69	60	0.078	-5	0.637	-114

The Broadband RF TMOS® Line 2W, 500MHz, 28V

Rev. V1

Table 1. Common Source S-Parameters ($V_{DS} = 13\text{ V}$, $I_D = 100\text{ mA}$) (continued)

f MHz	S ₁₁		S ₂₁		S ₁₂		S ₂₂	
	S ₁₁	∠	S ₂₁	∠	S ₁₂	∠	S ₂₂	∠
831	0.682	-136	2.67	59	0.077	-4	0.635	-114
836	0.681	-136	2.66	59	0.077	-5	0.638	-114
841	0.681	-136	2.64	58	0.079	-4	0.635	-115
846	0.679	-137	2.63	58	0.078	-4	0.637	-115
851	0.678	-137	2.61	58	0.077	-5	0.634	-115
856	0.682	-137	2.59	57	0.077	-5	0.635	-115
861	0.680	-137	2.59	57	0.077	-4	0.634	-115
866	0.681	-138	2.57	57	0.077	-6	0.635	-116
871	0.682	-138	2.55	56	0.075	-6	0.633	-116
876	0.684	-139	2.54	56	0.075	-5	0.631	-116
881	0.683	-139	2.53	56	0.075	-5	0.635	-117
886	0.681	-139	2.52	55	0.074	-6	0.633	-117
891	0.685	-140	2.50	55	0.074	-6	0.633	-117
896	0.683	-140	2.49	55	0.075	-6	0.638	-117
901	0.680	-140	2.47	54	0.073	-5	0.640	-118
905	0.681	-140	2.46	54	0.074	-7	0.637	-118
910	0.684	-140	2.44	54	0.074	-8	0.639	-118
915	0.683	-141	2.43	53	0.073	-6	0.639	-119
920	0.686	-141	2.42	53	0.074	-6	0.643	-119
925	0.683	-141	2.40	53	0.073	-7	0.641	-119
930	0.684	-141	2.39	52	0.072	-7	0.640	-120
935	0.682	-142	2.38	52	0.073	-6	0.638	-120
940	0.685	-142	2.37	52	0.072	-6	0.639	-120
945	0.683	-142	2.36	51	0.072	-7	0.638	-120
950	0.683	-143	2.34	51	0.071	-7	0.639	-120
955	0.683	-143	2.33	51	0.070	-7	0.638	-120
960	0.683	-143	2.32	51	0.073	-8	0.640	-121
965	0.683	-143	2.31	50	0.070	-8	0.640	-121
970	0.684	-144	2.30	50	0.071	-7	0.643	-121
975	0.684	-144	2.28	50	0.069	-8	0.640	-121
980	0.682	-144	2.27	49	0.068	-6	0.641	-122
985	0.685	-144	2.26	49	0.069	-9	0.643	-122
990	0.684	-145	2.25	48	0.067	-8	0.644	-122
995	0.683	-145	2.24	48	0.069	-8	0.644	-123
1000	0.684	-145	2.23	48	0.068	-8	0.643	-123

The Broadband RF TMOS® Line 2W, 500MHz, 28V

Rev. V1

Table 2. Common Source S-Parameters ($V_{DS} = 28\text{ V}$, $I_D = 100\text{ mA}$)

f MHz	S11		S21		S12		S22	
	S ₁₁	φ	S ₂₁	φ	S ₁₂	φ	S ₂₂	φ
5	1.002	-1	7.98	179	0.001	80	0.966	-1
10	0.999	-3	7.99	178	0.003	105	0.969	-2
15	0.999	-4	8.03	176	0.005	87	0.962	-3
20	0.998	-6	7.99	175	0.007	72	0.959	-4
25	0.999	-7	8.00	174	0.008	82	0.959	-5
30	0.997	-9	7.97	173	0.010	89	0.962	-6
35	0.999	-10	7.95	172	0.012	85	0.961	-7
40	0.996	-12	7.94	170	0.014	74	0.962	-8
45	0.994	-13	7.95	169	0.015	77	0.960	-9
50	0.991	-15	7.91	168	0.017	79	0.959	-10
55	0.990	-16	7.88	167	0.017	83	0.959	-11
60	0.988	-18	7.91	165	0.021	77	0.957	-12
65	0.989	-19	7.85	164	0.020	76	0.957	-13
70	0.983	-20	7.83	163	0.022	74	0.954	-15
75	0.981	-22	7.80	162	0.025	78	0.952	-16
80	0.980	-23	7.76	161	0.026	73	0.948	-17
85	0.979	-25	7.72	160	0.026	72	0.946	-18
90	0.977	-26	7.67	158	0.029	72	0.944	-19
95	0.973	-28	7.68	157	0.030	68	0.939	-19
100	0.970	-29	7.62	156	0.031	68	0.934	-20
105	0.970	-30	7.60	155	0.031	68	0.932	-21
109	0.967	-32	7.54	154	0.034	66	0.931	-22
114	0.961	-33	7.49	153	0.034	67	0.926	-23
119	0.960	-34	7.46	152	0.036	66	0.925	-24
124	0.956	-36	7.42	150	0.038	65	0.923	-25
129	0.954	-37	7.41	149	0.039	65	0.923	-26
134	0.948	-38	7.35	148	0.041	63	0.920	-27
139	0.946	-40	7.29	147	0.042	61	0.916	-28
144	0.944	-41	7.25	146	0.044	61	0.913	-29
149	0.939	-42	7.20	145	0.044	60	0.909	-30
154	0.939	-43	7.17	144	0.046	60	0.904	-31
159	0.935	-45	7.11	143	0.046	58	0.900	-32
164	0.932	-46	7.06	142	0.048	57	0.897	-33
169	0.928	-47	7.01	141	0.049	59	0.891	-34
174	0.927	-48	6.94	140	0.049	55	0.885	-34

The Broadband RF TMOS® Line 2W, 500MHz, 28V

Rev. V1

Table 2. Common Source S-Parameters ($V_{DS} = 28\text{ V}$, $I_D = 100\text{ mA}$)

f MHz	S11		S21		S12		S22	
	S ₁₁	∠	S ₂₁	∠	S ₁₂	∠	S ₂₂	∠
179	0.922	-49	6.89	139	0.051	55	0.882	-35
184	0.918	-51	6.85	138	0.052	54	0.883	-36
189	0.915	-52	6.82	137	0.053	53	0.878	-36
194	0.912	-53	6.78	136	0.053	50	0.874	-37
199	0.904	-54	6.71	135	0.054	52	0.867	-38
204	0.902	-55	6.65	134	0.054	51	0.868	-39
209	0.902	-56	6.62	133	0.056	50	0.866	-39
214	0.898	-58	6.57	132	0.058	50	0.863	-40
219	0.896	-59	6.52	132	0.059	49	0.858	-41
224	0.888	-60	6.47	131	0.059	48	0.850	-42
229	0.887	-61	6.42	130	0.060	46	0.847	-43
234	0.885	-62	6.36	129	0.061	46	0.846	-44
239	0.882	-63	6.35	128	0.062	46	0.837	-45
244	0.876	-64	6.25	127	0.062	45	0.833	-45
249	0.872	-65	6.19	126	0.063	43	0.829	-46
254	0.869	-66	6.15	125	0.064	43	0.828	-47
259	0.867	-67	6.09	125	0.065	43	0.823	-47
264	0.863	-68	6.06	124	0.065	42	0.818	-48
269	0.860	-69	6.01	123	0.065	42	0.816	-48
274	0.856	-70	5.95	122	0.067	41	0.815	-49
279	0.854	-71	5.91	121	0.068	40	0.812	-50
284	0.848	-72	5.87	120	0.068	39	0.809	-50
289	0.849	-73	5.84	120	0.068	38	0.807	-51
294	0.845	-74	5.78	119	0.069	38	0.805	-52
299	0.840	-75	5.73	118	0.070	36	0.800	-53
304	0.839	-75	5.68	117	0.068	37	0.795	-53
308	0.840	-76	5.63	117	0.069	35	0.793	-54
313	0.835	-77	5.59	116	0.071	35	0.790	-55
318	0.832	-78	5.54	115	0.071	35	0.784	-55
323	0.829	-79	5.48	114	0.070	34	0.783	-56
328	0.829	-80	5.45	114	0.072	33	0.778	-56
333	0.825	-81	5.39	113	0.071	33	0.776	-57
338	0.821	-82	5.35	112	0.073	32	0.771	-58

The Broadband RF TMOS® Line 2W, 500MHz, 28V

Rev. V1

Table 2. Common Source S-Parameters ($V_{DS} = 28\text{ V}$, $I_D = 100\text{ mA}$)

f MHz	S ₁₁		S ₂₁		S ₁₂		S ₂₂	
	S ₁₁	∠	S ₂₁	∠	S ₁₂	∠	S ₂₂	∠
343	0.818	-82	5.31	111	0.072	32	0.770	-58
348	0.816	-83	5.25	111	0.074	30	0.765	-59
353	0.814	-84	5.23	110	0.074	31	0.764	-59
358	0.810	-85	5.18	110	0.073	30	0.764	-59
363	0.810	-85	5.16	109	0.074	30	0.761	-60
368	0.807	-86	5.11	108	0.074	29	0.756	-61
373	0.805	-87	5.07	107	0.075	29	0.760	-61
378	0.801	-88	5.03	107	0.075	27	0.753	-62
383	0.799	-88	4.98	106	0.075	27	0.752	-62
388	0.796	-89	4.94	105	0.074	27	0.748	-63
393	0.796	-90	4.88	105	0.077	26	0.748	-63
398	0.790	-91	4.85	104	0.075	26	0.743	-64
403	0.794	-91	4.82	103	0.076	25	0.739	-64
408	0.789	-92	4.78	103	0.077	26	0.738	-65
413	0.785	-92	4.73	102	0.076	25	0.736	-66
418	0.788	-93	4.70	102	0.076	24	0.732	-66
423	0.783	-94	4.66	101	0.077	24	0.730	-66
428	0.784	-95	4.64	101	0.079	23	0.728	-67
433	0.779	-95	4.60	100	0.078	23	0.727	-67
438	0.779	-96	4.55	99	0.078	22	0.727	-68
443	0.775	-97	4.52	99	0.077	21	0.725	-68
448	0.778	-98	4.51	98	0.078	21	0.725	-69
453	0.776	-98	4.46	98	0.078	21	0.719	-69
458	0.771	-99	4.43	97	0.078	21	0.720	-70
463	0.771	-99	4.39	96	0.079	20	0.723	-70
468	0.769	-100	4.36	95	0.079	19	0.716	-71
473	0.767	-100	4.31	95	0.079	18	0.716	-71
478	0.765	-101	4.28	95	0.078	20	0.716	-72
483	0.764	-101	4.24	94	0.079	19	0.710	-72
488	0.763	-102	4.22	94	0.079	19	0.711	-72
493	0.762	-103	4.18	93	0.079	18	0.709	-73
498	0.760	-103	4.15	93	0.080	17	0.706	-73
503	0.760	-104	4.12	92	0.079	16	0.705	-74
507	0.758	-104	4.10	91	0.079	17	0.701	-74

The Broadband RF TMOS® Line 2W, 500MHz, 28V

Rev. V1

Table 2. Common Source S-Parameters ($V_{DS} = 28\text{ V}$, $I_D = 100\text{ mA}$) (continued)

f MHz	S ₁₁		S ₂₁		S ₁₂		S ₂₂	
	S ₁₁	∠	S ₂₁	∠	S ₁₂	∠	S ₂₂	∠
512	0.758	-105	4.08	91	0.079	16	0.700	-74
517	0.751	-105	4.03	90	0.078	16	0.700	-75
522	0.750	-106	4.00	90	0.080	15	0.700	-75
527	0.753	-106	4.00	89	0.079	16	0.698	-76
532	0.750	-107	3.96	89	0.079	14	0.699	-76
537	0.749	-107	3.94	88	0.079	15	0.696	-76
542	0.748	-108	3.90	87	0.080	13	0.696	-77
547	0.749	-109	3.88	87	0.080	13	0.697	-77
552	0.750	-109	3.85	87	0.079	14	0.693	-78
557	0.747	-110	3.82	86	0.078	13	0.697	-78
562	0.743	-110	3.78	86	0.079	12	0.695	-79
567	0.744	-111	3.75	85	0.079	12	0.689	-79
572	0.742	-111	3.73	85	0.078	11	0.690	-79
577	0.743	-112	3.70	84	0.080	12	0.689	-80
582	0.743	-112	3.67	84	0.080	11	0.691	-80
587	0.742	-112	3.64	83	0.078	11	0.688	-80
592	0.740	-113	3.62	83	0.080	10	0.685	-81
597	0.741	-113	3.61	82	0.078	10	0.682	-81
602	0.739	-114	3.59	82	0.078	10	0.685	-82
607	0.736	-114	3.56	82	0.079	9	0.682	-82
612	0.737	-115	3.53	81	0.077	9	0.684	-82
617	0.735	-115	3.52	81	0.078	10	0.682	-82
622	0.736	-115	3.50	80	0.078	9	0.680	-83
627	0.732	-116	3.47	80	0.078	8	0.681	-83
632	0.733	-117	3.45	79	0.077	8	0.682	-84
637	0.730	-117	3.41	79	0.078	8	0.684	-84
642	0.731	-117	3.40	78	0.077	8	0.683	-85
647	0.728	-118	3.37	78	0.077	7	0.679	-85
652	0.730	-118	3.35	77	0.077	8	0.679	-85
657	0.725	-119	3.32	77	0.077	7	0.679	-85
662	0.725	-119	3.29	76	0.079	6	0.679	-86
667	0.727	-120	3.27	76	0.078	5	0.677	-86
672	0.731	-120	3.26	75	0.077	6	0.676	-86
677	0.727	-120	3.24	75	0.077	5	0.675	-87

The Broadband RF TMOS® Line 2W, 500MHz, 28V

Rev. V1

Table 2. Common Source S-Parameters ($V_{DS} = 28\text{ V}$, $I_D = 100\text{ mA}$) (continued)

f MHz	S ₁₁		S ₂₁		S ₁₂		S ₂₂	
	S ₁₁	∠	S ₂₁	∠	S ₁₂	∠	S ₂₂	∠
682	0.725	-121	3.21	75	0.077	4	0.673	-87
687	0.726	-121	3.19	74	0.078	6	0.672	-87
692	0.724	-121	3.17	74	0.076	6	0.672	-88
697	0.728	-122	3.17	74	0.075	6	0.672	-88
702	0.724	-122	3.13	73	0.075	5	0.672	-88
706	0.724	-122	3.12	73	0.077	5	0.670	-89
711	0.722	-123	3.10	72	0.077	5	0.674	-89
716	0.722	-123	3.09	72	0.076	4	0.676	-89
721	0.723	-124	3.08	71	0.075	2	0.674	-90
726	0.720	-124	3.05	71	0.075	4	0.672	-90
731	0.719	-124	3.03	70	0.075	4	0.676	-90
736	0.720	-125	3.02	70	0.076	3	0.675	-91
741	0.716	-125	2.99	70	0.075	2	0.672	-91
746	0.718	-126	2.98	69	0.075	3	0.677	-91
751	0.715	-126	2.97	69	0.075	3	0.670	-92
756	0.717	-126	2.94	68	0.075	3	0.673	-92
761	0.716	-127	2.92	68	0.075	2	0.668	-92
766	0.717	-127	2.90	67	0.075	2	0.673	-93
771	0.717	-128	2.88	67	0.073	2	0.669	-93
776	0.714	-128	2.86	67	0.076	1	0.668	-93
781	0.718	-128	2.86	66	0.074	1	0.668	-93
786	0.718	-129	2.85	66	0.073	1	0.670	-94
791	0.718	-129	2.82	66	0.073	1	0.670	-94
796	0.716	-129	2.81	65	0.072	0	0.668	-94
801	0.715	-130	2.79	65	0.073	-1	0.671	-95
806	0.718	-130	2.77	65	0.071	1	0.669	-95
811	0.714	-130	2.77	64	0.072	0	0.672	-95
816	0.714	-130	2.74	64	0.072	0	0.673	-96
821	0.714	-131	2.72	63	0.070	0	0.671	-96
826	0.715	-131	2.71	63	0.073	0	0.675	-96
831	0.713	-131	2.69	63	0.071	0	0.672	-96
836	0.713	-131	2.68	62	0.072	-1	0.672	-97
841	0.712	-132	2.67	62	0.069	0	0.671	-97
846	0.710	-132	2.65	61	0.071	-1	0.672	-97
851	0.708	-132	2.63	61	0.071	-1	0.670	-97

The Broadband RF TMOS® Line 2W, 500MHz, 28V

Rev. V1

Table 2. Common Source S-Parameters ($V_{DS} = 28\text{ V}$, $I_D = 100\text{ mA}$) (continued)

f MHz	S ₁₁		S ₂₁		S ₁₂		S ₂₂	
	S ₁₁	∠	S ₂₁	∠	S ₁₂	∠	S ₂₂	∠
856	0.712	-133	2.62	61	0.071	-2	0.669	-98
861	0.710	-133	2.61	61	0.071	-2	0.669	-98
866	0.710	-134	2.59	60	0.071	-2	0.669	-98
871	0.710	-134	2.58	60	0.071	-2	0.669	-98
876	0.713	-134	2.57	59	0.069	-3	0.666	-99
881	0.711	-135	2.56	59	0.068	-3	0.667	-99
886	0.710	-135	2.54	59	0.069	-3	0.666	-99
891	0.711	-135	2.52	58	0.067	-3	0.668	-100
896	0.711	-136	2.52	58	0.070	-2	0.670	-100
901	0.709	-136	2.50	57	0.069	-5	0.669	-101
905	0.711	-136	2.49	57	0.069	-3	0.671	-101
910	0.711	-136	2.47	57	0.068	-4	0.674	-101
915	0.710	-137	2.46	56	0.068	-2	0.673	-101
920	0.712	-137	2.45	56	0.066	-4	0.673	-102
925	0.708	-137	2.42	56	0.067	-4	0.673	-102
930	0.709	-137	2.42	55	0.068	-3	0.673	-102
935	0.709	-138	2.41	55	0.066	-4	0.670	-102
940	0.709	-138	2.40	55	0.066	-2	0.672	-102
945	0.709	-138	2.39	54	0.065	-3	0.672	-103
950	0.708	-139	2.38	54	0.066	-4	0.671	-103
955	0.711	-139	2.36	54	0.065	-5	0.669	-103
960	0.709	-139	2.35	54	0.064	-4	0.672	-103
965	0.708	-140	2.34	53	0.064	-3	0.671	-104
970	0.707	-140	2.33	53	0.065	-5	0.673	-104
975	0.706	-140	2.32	52	0.065	-4	0.671	-104
980	0.707	-140	2.30	52	0.065	-4	0.669	-104
985	0.707	-140	2.29	51	0.064	-6	0.674	-105
990	0.708	-141	2.28	51	0.063	-4	0.674	-105
995	0.708	-141	2.28	51	0.063	-5	0.674	-105
1000	0.710	-141	2.26	50	0.063	-5	0.676	-106

PACKAGE DIMENSIONS

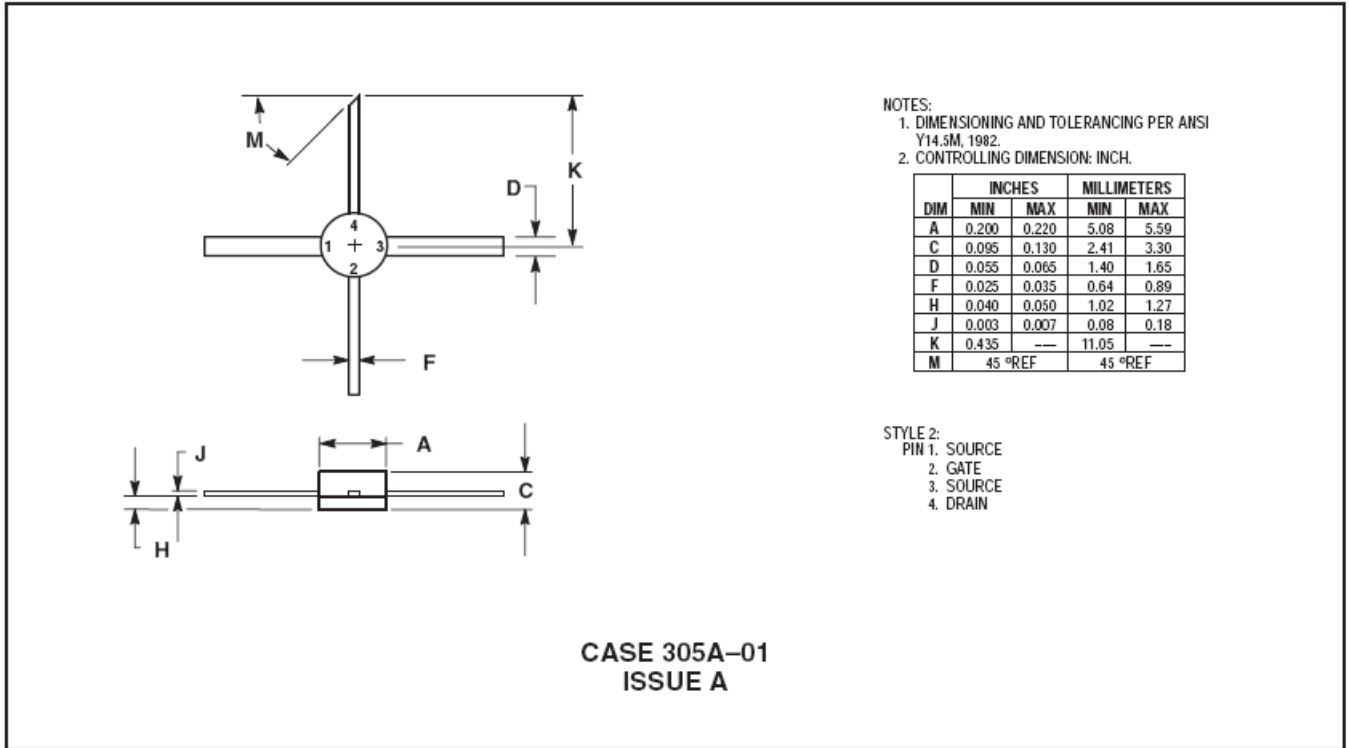

M/A-COM Technology Solutions Inc. All rights reserved.

Information in this document is provided in connection with M/A-COM Technology Solutions Inc ("MACOM") products. These materials are provided by MACOM as a service to its customers and may be used for informational purposes only. Except as provided in MACOM's Terms and Conditions of Sale for such products or in any separate agreement related to this document, MACOM assumes no liability whatsoever. MACOM assumes no responsibility for errors or omissions in these materials. MACOM may make changes to specifications and product descriptions at any time, without notice. MACOM makes no commitment to update the information and shall have no responsibility whatsoever for conflicts or incompatibilities arising from future changes to its specifications and product descriptions. No license, express or implied, by estoppel or otherwise, to any intellectual property rights is granted by this document.

THESE MATERIALS ARE PROVIDED "AS IS" WITHOUT WARRANTY OF ANY KIND, EITHER EXPRESS OR IMPLIED, RELATING TO SALE AND/OR USE OF MACOM PRODUCTS INCLUDING LIABILITY OR WARRANTIES RELATING TO FITNESS FOR A PARTICULAR PURPOSE, CONSEQUENTIAL OR INCIDENTAL DAMAGES, MERCHANTABILITY, OR INFRINGEMENT OF ANY PATENT, COPYRIGHT OR OTHER INTELLECTUAL PROPERTY RIGHT. MACOM FURTHER DOES NOT WARRANT THE ACCURACY OR COMPLETENESS OF THE INFORMATION, TEXT, GRAPHICS OR OTHER ITEMS CONTAINED WITHIN THESE MATERIALS. MACOM SHALL NOT BE LIABLE FOR ANY SPECIAL, INDIRECT, INCIDENTAL, OR CONSEQUENTIAL DAMAGES, INCLUDING WITHOUT LIMITATION, LOST REVENUES OR LOST PROFITS, WHICH MAY RESULT FROM THE USE OF THESE MATERIALS.

MACOM products are not intended for use in medical, lifesaving or life sustaining applications. MACOM customers using or selling MACOM products for use in such applications do so at their own risk and agree to fully indemnify MACOM for any damages resulting from such improper use or sale.

Looking for pricing, stock, or lifecycle information?

Click below to explore more details on WIN SOURCE:

- ⊖ [View MRF158 on WIN SOURCE](#)
- ⊖ [M/A-Com Technology Solutions Information](#)

Optimize Your Supply Chain with WIN SOURCE Solutions

- ✓ Global Sourcing Solution
- ✓ Obsolete Management
- ✓ Cost Control Management
- ✓ Shortage Management
- ✓ Alternative Solution
- ✓ Excess Inventory Management