



**THE DATASHEET OF
BA6162F-E2**



Reset IC with battery backup function

BA6129AF / BA6162 / BA6162F

The BA6129AF, BA6162, and BA6162F are reset ICs with a battery backup function, designed for equipment using SRAMs and other similar components. These ICs are configured of a reset signal and CS signal output unit and a power supply switching unit. If the BA6129AF detects that the power supply has dropped to 3.5V or lower, it outputs the CS, CSB, and Reset signals to set the SRAM in backup mode. If the voltage drops to 3.3V or lower, the power supply switches to the battery. With the BA6162 and BA6162F, in the same way, a power supply of 4.2V is detected, and if the voltage drops to 3.3V or lower, the power supply switches to the battery. These ICs allow SRAMs to be write protected and allow the system to be reset, in addition to switching between the power supply and the battery.

●Applications

Equipment using SRAMs (cards, cassettes, facsimile machines, copiers, word processors, personal computers, etc.)

●Features

- 1) Equipped with battery backup function.
- 2) Equipped with both CS signals (CS and CSB) and Reset signals.
- 3) Low current dissipation when powered from battery.
- 4) Low voltage loss when powered from battery.
- 5) Smooth switching between power supply and battery.

●Absolute maximum ratings (Ta = 25°C)

Parameter	Symbol	Limits	Unit
Power supply voltage	V _{CC}	7.0	V
Output current 1	I _{OUT1}	- 80 (BA6129AF) - 40 (BA6162 / BA6162F)	mA
Output current 2	I _{OUT2}	- 200	μA
Power dissipation	P _d	900* ¹ (BA6162) 550* ² (BA6129AF) (BA6162F)	mW
Operating temperature	T _{opr}	- 20 ~ + 75	°C
Storage temperature	T _{stg}	- 40 ~ + 125	°C

I_{OUT1} indicates the output current on the V_{CC} side, and I_{OUT2} the output current on the V_{BAT} side.

*1 Reduced by 9.0mW for each increase in Ta of 1°C over 25°C.

*2 Reduced by 5.5mW for each increase in Ta of 1°C over 25°C.

●Block diagram

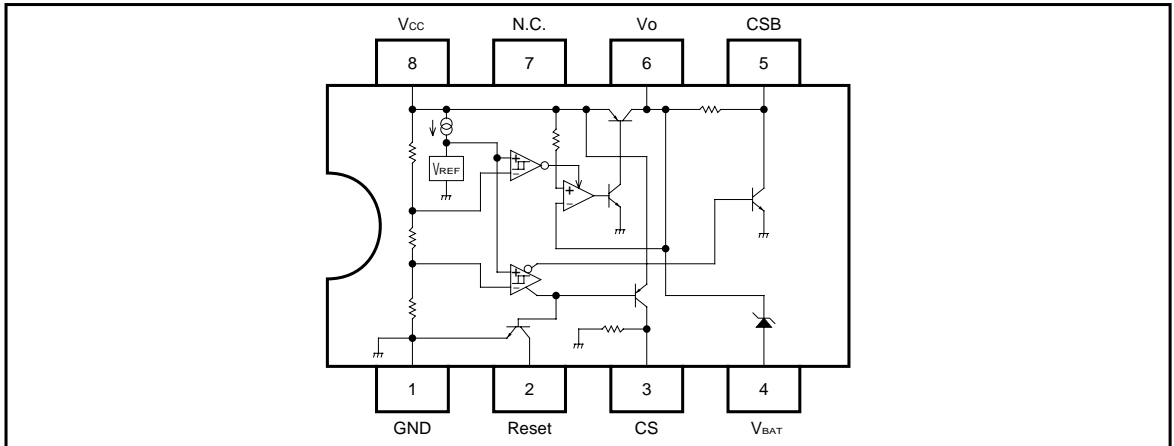

●Pin descriptions

Pin No.	Pin name	Function
1	GND	Substrate GND
2	Reset	Reset output
3	CS	CS output
4	VBAT	Battery power supply
5	CSB	CSB output
6	Vo	Power supply output
7	N.C.	—
8	Vcc	Power supply voltage

●Input / output circuit

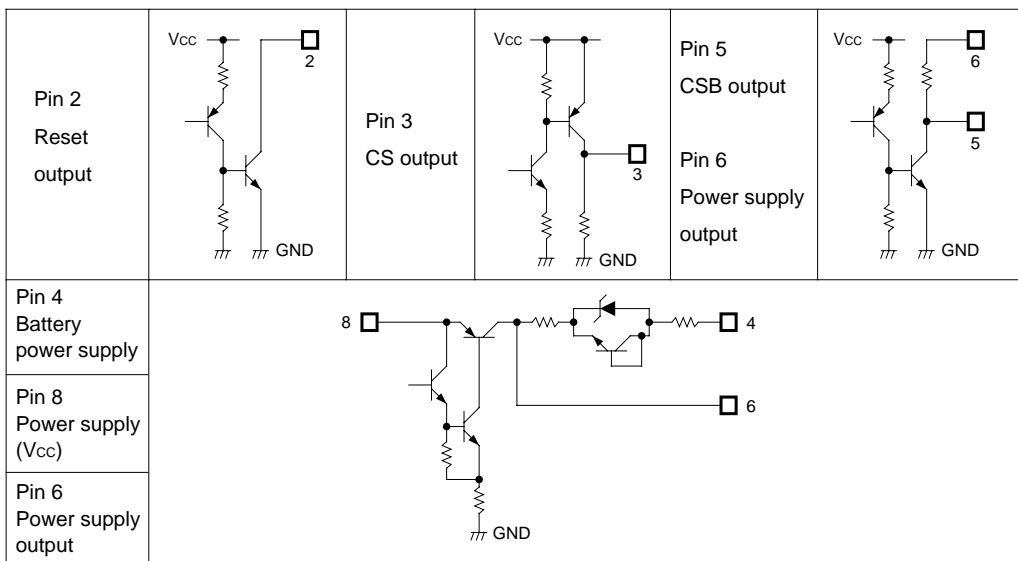

●Electrical characteristics

BA6129AF (unless otherwise noted, $T_a = 25^\circ\text{C}$, $V_{\text{RES}} = V_{\text{CC}} = 5\text{V}$, $R_{\text{RES}} = 10\text{k}\Omega$)

Parameter	Symbol	Min.	Typ.	Max.	Unit	Conditions
No-load current dissipation	I_{CC}	—	—	2.0	mA	$V_{\text{CC}} = 5\text{V}$, $V_{\text{BAT}} = 3\text{V}$
I / O voltage differential 1	V_{SAT1}	—	0.03	0.05	V	$V_{\text{CC}} = 5\text{V}$, $V_{\text{BAT}} = 3\text{V}$, $I_{\text{O}} = -1\text{mA}$
Vo output voltage 1	V_{O1}	4.95	4.97	—	V	$V_{\text{CC}} = 5\text{V}$, $V_{\text{BAT}} = 3\text{V}$, $I_{\text{O}} = -1\text{mA}$
Vo output voltage 2	V_{O2}	4.70	4.90	—	V	$V_{\text{CC}} = 5\text{V}$, $V_{\text{BAT}} = 3\text{V}$, $I_{\text{O}} = -15\text{mA}$
Vo output voltage 3	V_{O3}	4.50	4.86	—	V	$V_{\text{CC}} = 5\text{V}$, $V_{\text{BAT}} = 3\text{V}$, $I_{\text{O}} = -30\text{mA}$
Detection voltage	V_{S}	3.35	3.50	3.65	V	$V_{\text{CC}} = \text{H} \rightarrow \text{L}$
Detection hysteresis voltage	V_{SH}	—	100	—	mV	$V_{\text{CC}} = \text{L} \rightarrow \text{H}$
Reset output low level voltage	V_{RESL}	—	—	0.4	V	$V_{\text{CC}} = 3\text{V}$
Reset leakage current	I_{RESH}	—	—	0.1	μA	$V_{\text{CC}} = 5\text{V}$, $V_{\text{RES}} = 7\text{V}$
Reset operating limit voltage	V_{OPL}	—	0.8	1.2	V	$V_{\text{CC}} = \text{H} \rightarrow \text{L}$, $V_{\text{RES}} \leq 0.4\text{V}$
CS output low level voltage	V_{CSL}	—	—	0.1	V	$V_{\text{CC}} = 3\text{V}$, $V_{\text{BAT}} = 3\text{V}$, $I_{\text{CS}} = +1\mu\text{A}$
CS output high level voltage	V_{CSH}	4.9	—	—	V	$V_{\text{CC}} = 5\text{V}$, $V_{\text{BAT}} = 3\text{V}$, $I_{\text{CS}} = -1\mu\text{A}$
CSB output low level voltage	V_{CSBL}	—	—	0.1	V	$V_{\text{CC}} = 5\text{V}$, $V_{\text{BAT}} = 3\text{V}$, $I_{\text{CSB}} = +1\mu\text{A}$
CSB output high level voltage	V_{CSBH}	$V_{\text{O}} - 0.1$	—	—	V	$V_{\text{CC}} = 3\text{V}$, $V_{\text{BAT}} = 3\text{V}$, $I_{\text{CSB}} = -1\mu\text{A}$
Detection voltage temperature characteristic	V_{S}	-0.05	—	+0.05	% / $^\circ\text{C}$	—
Switching voltage	V_{B}	3.15	3.30	3.45	V	$V_{\text{CC}} = \text{H} \rightarrow \text{L}$, $V_{\text{BAT}} = 3\text{V}$, $R_{\text{O}} = 200\text{k}\Omega$
Switching hysteresis voltage	V_{BH}	—	100	—	mV	$V_{\text{CC}} = \text{L} \rightarrow \text{H}$, $V_{\text{BAT}} = 3\text{V}$, $R_{\text{O}} = 200\text{k}\Omega$
Switching voltage temperature characteristic	V_{B}	-0.05	—	+0.05	% / $^\circ\text{C}$	—
Backup current dissipation	I_{CCB}	—	—	0.5	μA	$V_{\text{CC}} = \text{GND}$, $V_{\text{BAT}} = 3\text{V}$
I / O voltage differential 2	V_{SAT2}	—	0.20	0.30	V	$V_{\text{CC}} = \text{GND}$, $V_{\text{BAT}} = 3\text{V}$, $I_{\text{O}} = -1\mu\text{A}$
Vo output voltage 4	V_{O4}	2.70	2.80	—	V	$V_{\text{CC}} = \text{GND}$, $V_{\text{BAT}} = 3\text{V}$, $I_{\text{O}} = -1\mu\text{A}$
Vo output voltage 5	V_{O5}	2.60	2.67	—	V	$V_{\text{CC}} = \text{GND}$, $V_{\text{BAT}} = 3\text{V}$, $I_{\text{O}} = -100\mu\text{A}$
Vo output voltage 6	V_{O6}	$V_{\text{CC}} - 0.5$	—	—	V	$I_{\text{O}} = -80\text{mA}$
Reverse current	I_{OR}	—	—	0.1	μA	$V_{\text{CC}} = 5\text{V}$, $V_{\text{BAT}} = \text{GND}$

(Note) I_{O} , I_{CS} , and I_{CSB} are + when flowing toward the pin and - when flowing away from the pin.

○ Not designed for radiation resistance.

BA6162 / F (unless otherwise noted, $T_a = 25^\circ\text{C}$, $V_{\text{RES}} = V_{\text{CC}} = 5\text{V}$, $R_{\text{RES}} = 10\text{k}\Omega$)

Parameter	Symbol	Min.	Typ.	Max.	Unit	Conditions
No-load current dissipation	I_{CC}	—	—	2.0	mA	$V_{\text{CC}} = 5\text{V}$, $V_{\text{BAT}} = 3\text{V}$
I / O voltage differential 1	V_{SAT1}	—	0.03	0.05	V	$V_{\text{CC}} = 5\text{V}$, $V_{\text{BAT}} = 3\text{V}$, $I_{\text{O}} = -1\text{mA}$
Vo output voltage 1	V_{O1}	4.95	4.97	—	V	$V_{\text{CC}} = 5\text{V}$, $V_{\text{BAT}} = 3\text{V}$, $I_{\text{O}} = -1\text{mA}$
Vo output voltage 2	V_{O2}	4.70	4.90	—	V	$V_{\text{CC}} = 5\text{V}$, $V_{\text{BAT}} = 3\text{V}$, $I_{\text{O}} = -15\text{mA}$
Vo output voltage 3	V_{O3}	4.50	4.86	—	V	$V_{\text{CC}} = 5\text{V}$, $V_{\text{BAT}} = 3\text{V}$, $I_{\text{O}} = -30\text{mA}$
Detection voltage	V_{S}	4.00	4.20	4.40	V	$V_{\text{CC}} = \text{H} \rightarrow \text{L}$
Detection hysteresis voltage	V_{SH}	—	100	—	mV	$V_{\text{CC}} = \text{L} \rightarrow \text{H}$
Reset output low level voltage	V_{RESL}	—	—	0.4	V	$V_{\text{CC}} = 3.7\text{V}$
Reset leakage current	I_{RESH}	—	—	0.1	μA	$V_{\text{CC}} = 5\text{V}$, $V_{\text{RES}} = 7\text{V}$
Reset operating limit voltage	V_{OPL}	—	0.8	1.2	V	$V_{\text{CC}} = \text{H} \rightarrow \text{L}$, $V_{\text{RES}} \leq 0.4\text{V}$
CS output low level voltage	V_{CSL}	—	—	0.1	V	$V_{\text{CC}} = 3.7\text{V}$, $V_{\text{BAT}} = 3\text{V}$, $I_{\text{CS}} = +1\mu\text{A}$
CS output high level voltage	V_{CSH}	4.9	—	—	V	$V_{\text{CC}} = 5\text{V}$, $V_{\text{BAT}} = 3\text{V}$, $I_{\text{CS}} = -1\mu\text{A}$
CSB output low level voltage	V_{CSBL}	—	—	0.1	V	$V_{\text{CC}} = 5\text{V}$, $V_{\text{BAT}} = 3\text{V}$, $I_{\text{CSB}} = +1\mu\text{A}$
CSB output high level voltage	V_{CSBH}	$V_{\text{O}} - 0.1$	—	—	V	$V_{\text{CC}} = 3.7\text{V}$, $V_{\text{BAT}} = 3\text{V}$, $I_{\text{CSB}} = -1\mu\text{A}$
Detection voltage temperature characteristic	K_{VS}	-0.05	—	+0.05	% / $^\circ\text{C}$	—
Switching voltage	V_{B}	3.15	3.30	3.45	V	$V_{\text{CC}} = \text{H} \rightarrow \text{L}$, $V_{\text{BAT}} = 3\text{V}$, $R_{\text{O}} = 200\text{k}\Omega$
Switching hysteresis voltage	V_{BH}	—	100	—	mV	$V_{\text{CC}} = \text{L} \rightarrow \text{H}$, $V_{\text{BAT}} = 3\text{V}$, $R_{\text{O}} = 200\text{k}\Omega$
Switching voltage temperature characteristic	K_{VB}	-0.05	—	+0.05	% / $^\circ\text{C}$	—
Backup current dissipation	I_{CCB}	—	—	0.5	μA	$V_{\text{CC}} = \text{GND}$, $V_{\text{BAT}} = 3\text{V}$
I / O voltage differential 2	V_{SAT2}	—	0.20	0.03	V	$V_{\text{CC}} = \text{GND}$, $V_{\text{BAT}} = 3\text{V}$, $I_{\text{O}} = -1\mu\text{A}$
Vo output voltage 4	V_{O4}	2.70	2.80	—	V	$V_{\text{CC}} = \text{GND}$, $V_{\text{BAT}} = 3\text{V}$, $I_{\text{O}} = -1\mu\text{A}$
Vo output voltage 5	V_{O5}	2.60	2.67	—	V	$V_{\text{CC}} = \text{GND}$, $V_{\text{BAT}} = 3\text{V}$, $I_{\text{O}} = -100\mu\text{A}$
Vo output voltage 6	V_{O6}	$V_{\text{CC}} - 0.5$	—	—	V	$I_{\text{O}} = -40\text{mA}$
Reverse current	I_{OR}	—	—	0.1	μA	$V_{\text{CC}} = 5\text{V}$, $V_{\text{BAT}} = \text{GND}$

(Note) I_{O} , I_{CS} , and I_{CSB} are + when flowing toward the pin and - when flowing away from the pin.

○ Not designed for radiation resistance.

● Measurement circuit

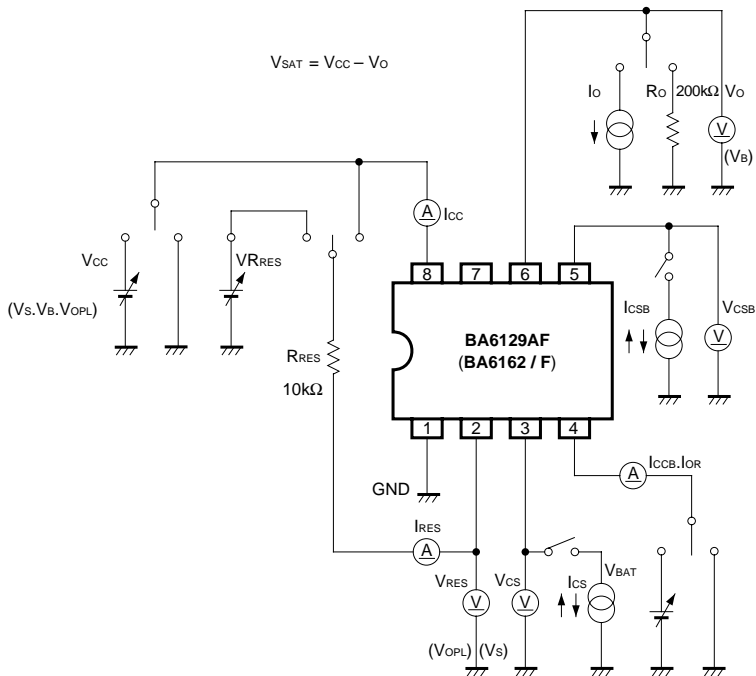

Fig. 1

●Circuit operation

These ICs have two distinct functions, a logic output function and a power supply switching function.

The logic output circuit consists of the following:

- (1) Reset output (NPN Tr open collector)
- (2) CS output (PNP Tr open collector + pull-down resistor)
- (3) CSB output (NPN Tr open collector + pull-up resistor)

The power supply switching circuit consists of a PNP power transistor and an SBD (Schottky barrier diode). The normal power supply V_{CC} and the battery backup power supply (V_{BAT}) are both connected to the switching circuit. When the PNP power transistor is turned on and off, the IC power is switched from the normal power supply to the battery backup power supply, and vice versa.

The power supply voltage detection circuit consists of a standard voltage source V_{REF} and a hysteresis comparator. The power supply V_{CC} is detected using a split resistance. When the power supply voltage drops below the detection voltage (BA6129AF: $V_S = 3.5V_{typ.}$ when V_{CC} drops and $V_S + 0.1V_{typ.}$ when V_{CC} rises;

BA6162 / F: $V_S = 4.2V_{typ.}$ when V_{CC} drops, and $V_S + 0.1V_{typ.}$ when V_{CC} rises), the Reset signal (Low) and the CS signal (CS-Low, CSB-High) are output by the logic output function, and the SRAM (or other memory device) is switched to backup mode.

If the power supply V_{CC} drops further and goes below the switching voltage (BA6129AF and BA6162 / F: $V_B = 3.3V_{typ.}$ when V_{CC} drops, $V_B + 0.1V_{typ.}$ when V_{CC} rises), the SBD develops a forward bias because the PNP power transistor is off. The power supply output V_O switches from the power supply V_{CC} to the battery power supply (V_{BAT}).

When the normal power supply V_{CC} rises, the above process is reversed.

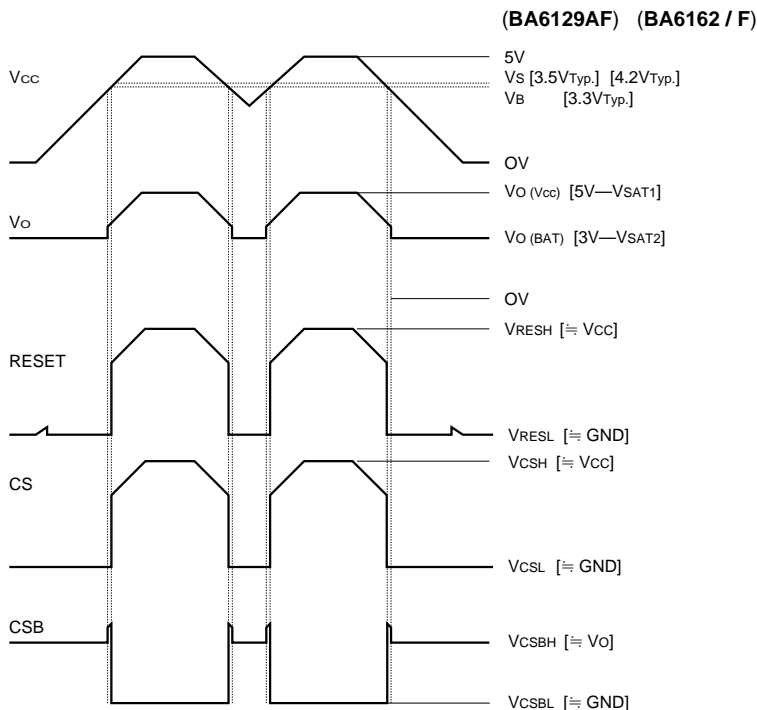

Fig. 2 Timing chart

●Application example

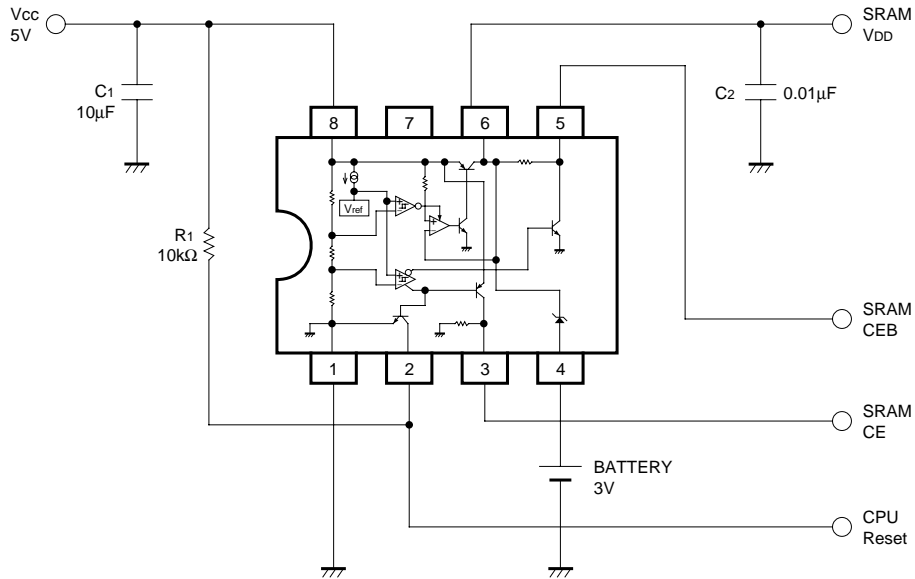

Fig. 3

●Operation notes

(1) Power supply V_{CC}

These ICs are designed to operate with at $V_{CC} = 5V$, but can also operate at V_{CC} values of other than 5V. However, the following conditions must be met: (equation)

$$\begin{cases} V_S + V_{SH} < V_{CC} < V_{CCMax.} \\ V_{CC} - V_{BAT} < 5V \end{cases}$$

(2) Battery voltage V_{BAT}

These ICs are designed to operate with at $V_{BAT} = 3V$, but can also operate at V_{BAT} values of other than 3V. However, the following conditions must be met: (equation)

$$\begin{cases} V_{BAT} < V_B \\ V_{CC} - V_{BAT} < 5V \end{cases}$$

where) V_S : detection voltage
 V_{SH} : detection hysteresis voltage
 V_B : switching voltage

●Electrical characteristic curves (BA6129AF)

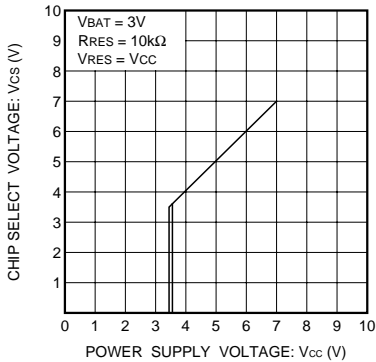

Fig. 4 CS output voltage vs. power supply voltage

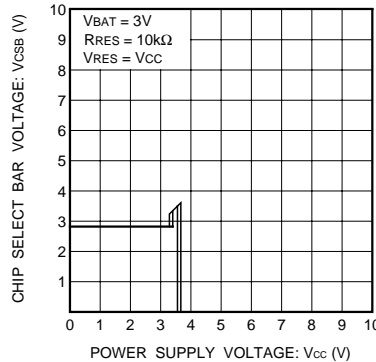

Fig. 5 CSB output voltage vs. power supply voltage

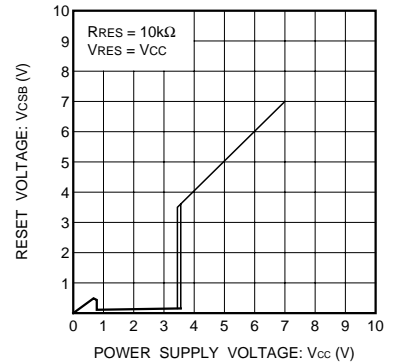

Fig. 6 Reset output voltage vs. power supply voltage

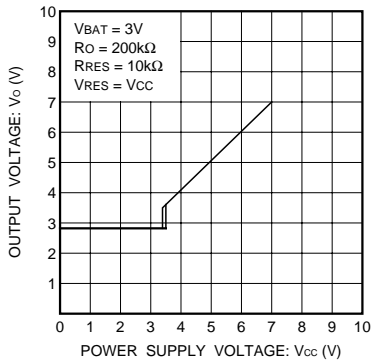

Fig. 7 Output voltage vs. power supply voltage

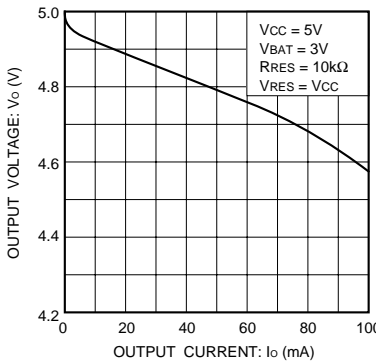

Fig. 8 Output voltage vs. output current (I) (when power supply is detected)

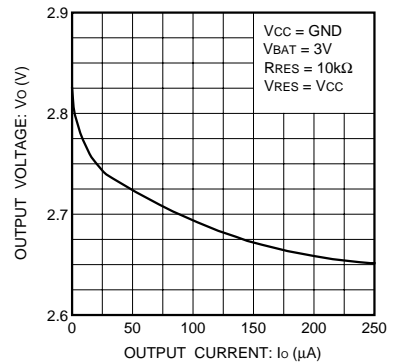

Fig. 9 Output voltage vs. output current (II) (when using battery backup)

●Electrical characteristic curves (BA6162 / F)

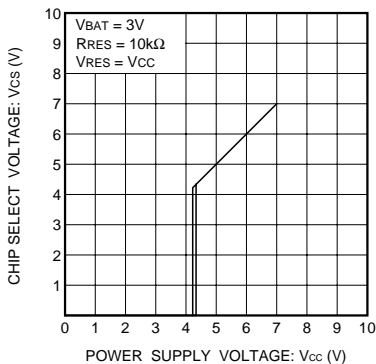

Fig. 10 CS output voltage vs. power supply voltage

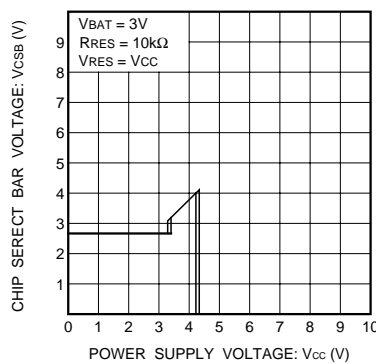

Fig. 11 CSB output voltage vs. power supply voltage

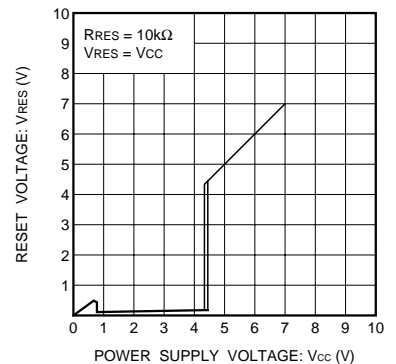

Fig. 12 Reset output voltage vs. power supply voltage

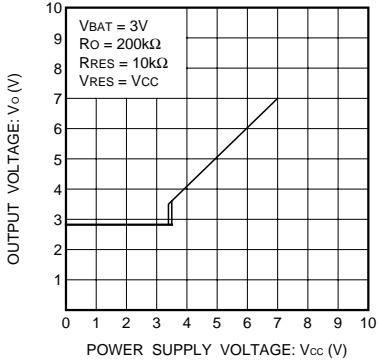

Fig. 13 Output voltage vs. power supply voltage

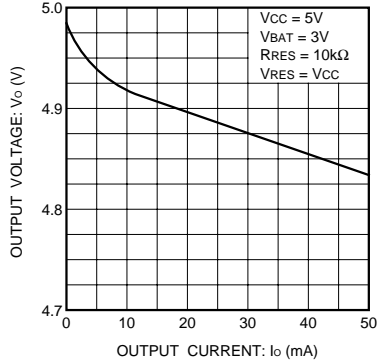

Fig. 14 Output voltage vs. output current (I) (when power supply is detected)

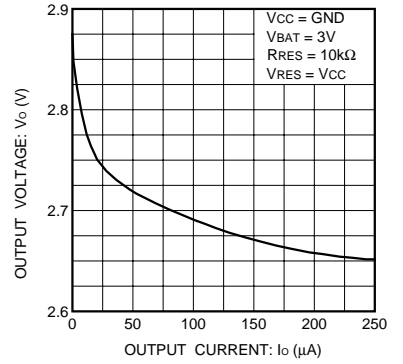
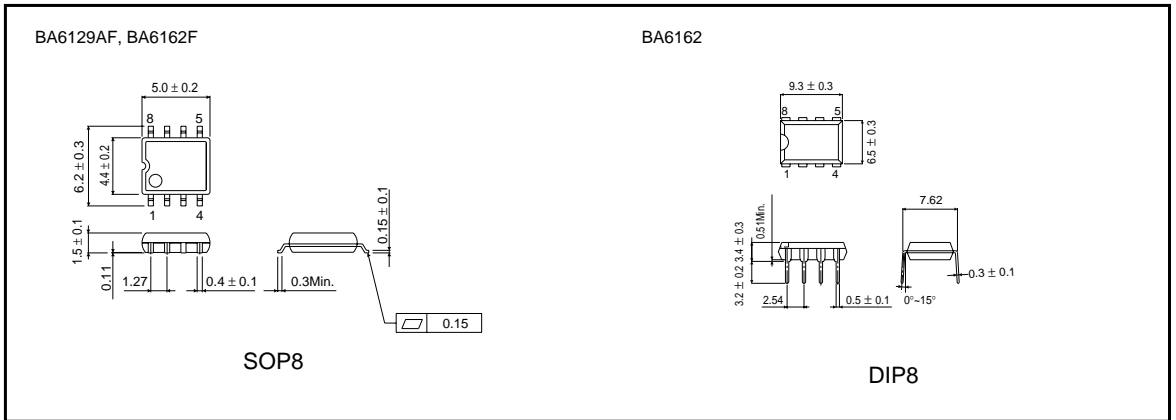

Fig. 15 Output voltage vs. output current (II) (when using battery backup)

●External dimensions (Units: mm)



Notes

- No technical content pages of this document may be reproduced in any form or transmitted by any means without prior permission of ROHM CO.,LTD.
- The contents described herein are subject to change without notice. The specifications for the product described in this document are for reference only. Upon actual use, therefore, please request that specifications to be separately delivered.
- Application circuit diagrams and circuit constants contained herein are shown as examples of standard use and operation. Please pay careful attention to the peripheral conditions when designing circuits and deciding upon circuit constants in the set.
- Any data, including, but not limited to application circuit diagrams information, described herein are intended only as illustrations of such devices and not as the specifications for such devices. ROHM CO.,LTD. disclaims any warranty that any use of such devices shall be free from infringement of any third party's intellectual property rights or other proprietary rights, and further, assumes no liability of whatsoever nature in the event of any such infringement, or arising from or connected with or related to the use of such devices.
- Upon the sale of any such devices, other than for buyer's right to use such devices itself, resell or otherwise dispose of the same, no express or implied right or license to practice or commercially exploit any intellectual property rights or other proprietary rights owned or controlled by
- ROHM CO., LTD. is granted to any such buyer.
- Products listed in this document use silicon as a basic material.
Products listed in this document are no antiradiation design.

The products listed in this document are designed to be used with ordinary electronic equipment or devices (such as audio visual equipment, office-automation equipment, communications devices, electrical appliances and electronic toys).

Should you intend to use these products with equipment or devices which require an extremely high level of reliability and the malfunction of which would directly endanger human life (such as medical instruments, transportation equipment, aerospace machinery, nuclear-reactor controllers, fuel controllers and other safety devices), please be sure to consult with our sales representative in advance.



About Export Control Order in Japan

Products described herein are the objects of controlled goods in Annex 1 (Item 16) of Export Trade Control Order in Japan.

In case of export from Japan, please confirm if it applies to "objective" criteria or an "informed" (by MITI clause) on the basis of "catch all controls for Non-Proliferation of Weapons of Mass Destruction.

Looking for pricing, stock, or lifecycle information?

Click below to explore more details on WIN SOURCE:

-  [View BA6162F-E2 on WIN SOURCE](#)
-  [Rohm Semiconductor Information](#)

Optimize Your Supply Chain with WIN SOURCE Solutions

-  Global Sourcing Solution
-  Obsolete Management
-  Cost Control Management
-  Shortage Management
-  Alternative Solution
-  Excess Inventory Management