



THE DATASHEET OF ZL8802ALAFT



ZL8802

Dual Channel/Dual Phase PMBus ChargeMode Control DC/DC Digital Controller

FN8760
Rev.3.00
Nov 8, 2017

The [ZL8802](#) is a dual output or dual phase digital DC/DC controller. Each output can operate independently or be used together in a dual phase configuration for high current applications supporting 2-, 4-, 6-, and 8-phase operation with up to four ZL8802 controllers.

The ZL8802 supports a wide range of output voltages (0.54V to 5.5V) operating from input voltages as low as 4.5V up to 14V.

With the fully digital ChargeMode control, the ZL8802 will respond to a transient load step within a single switching cycle. This unique compensation-free modulation technique allows designs to meet transient specifications with minimum output capacitance, thus saving cost and board space.

The proprietary single-wire Digital-DC™ (DDC) serial bus enables the ZL8802 to communicate between other Intersil digital power ICs. By using the DDC, the ZL8802 achieves complex functions such as inter-IC phase current balancing, sequencing, and fault spreading. This eliminates complicated power supply managers with numerous external discrete components.

The ZL8802 features fast output overcurrent protection. The input voltage, output voltages, and DrMOS/MOSFET driver supply voltages are overvoltage and undervoltage protected. Two external temperature sensors and one internal temperature sensor are available for temperature monitoring, one of which can be configured for under- and over-temperature protection. A snapshot parametric capture feature allows users to take a snapshot of operating and fault data during normal or fault conditions.

Integrated Low Dropout (LDO) regulators allow the ZL8802 to operate from a single input supply eliminating the need for additional linear regulators. The VDRV LDO output can be used to power external drivers or DrMOS devices.

With full PMBus compliance, the ZL8802 is capable of measuring and reporting input voltage, input current, output voltage, output current, as well as the device's internal temperature, two external temperatures, and an auxiliary voltage or temperature input.

Features

- Unique compensation-free design – always stable
- Output voltage range: 0.54V to 5.5V
- Input voltage range: 4.5V to 14V
- 1% output voltage accuracy over line, load, and temperature
- ChargeMode control achieves fast transient response, reduced output capacitance, and provides output stability without compensation.
- 2-channel output, 2-, 4-, 6-, or 8-phase output with two, three, or four devices
- Switching frequency range 200kHz to 1.33MHz
- Proprietary single-wire DDC (Digital-DC) serial bus enables voltage sequencing and fault spreading with other Intersil digital power ICs
- Inductor peak and averaged over and undercurrent protection
- Digital fault protection for output voltage UV/OV, input voltage UV/OV, temperature, and MOSFET driver voltage
- Accurate average output current measurement with adjustable gain settings for sensing with SPS current monitor outputs or high current, low DCR inductors
- Monitor ADC measures input voltage, input current, output voltage, driver voltage, internal and external temperature
- Nonvolatile memory for storing operating parameters and fault events
- PMBus compliant

Applications

- Servers and storage equipment
- Telecom and datacom equipment
- Power supplies (memory, DSP, ASIC, FPGA)

Related Literature

- For a full list of related documents, visit our website - [ZL8802](#) product page

TABLE 1. KEY DIFFERENCES BETWEEN FAMILY OF PARTS

PART NUMBER	DUAL OUTPUT	DUAL PHASE	DDC CURRENT SHARE	SPS SUPPORT
ZL8800	Yes	Yes	No	No
ZL8801	No	Yes	Yes	No
ZL8802	Yes	Yes	Yes	Yes

Table of Contents

Two-Phase Application	3
Block Diagram	4
Pin Configuration	5
Pin Description	5
Ordering Information	7
Absolute Maximum Ratings	8
Thermal Information	8
Recommended Operating Conditions	8
Electrical Specifications	8
ZL8802 Overview	11
Digital-DC Architecture Overview	11
Power Management Overview	11
Pin-Strap Pins	11
Configurable Pins	12
SMBus Device Address Selection (SA)	12
Output Voltage and VOUT_MAX Selection (VSET0, 1)	12
Switching Frequency Setting (SYNC)	12
Input Voltage Undervoltage Lockout Setting (UVLO)	13
Configuration Setting (CFG)	13
ChargeMode Control (ASCR) Setting (ASCRCFG)	14
Start-Up and Shutdown Settings	14
Internal Bias Regulators and Input Supply Connections	14
Start-Up Procedure	15
Ton-Delay and Rise Times	15
Enable Pin Operation and Timing	16
Power-Good	16
Power Management Functional Description	16
Output Overvoltage Protection	16
Output Prebias Protection	16
Output Overcurrent Protection	17
Current Limit Configuration	18
Input Current Monitor	18
Thermal Overload Protection	18
Voltage Tracking	18
External Voltage Monitoring	19
SMBus Communications	19
Digital-DC Bus	19
Phase Spreading	20
Output Sequencing	20
Fault Spreading	20
Active Current Sharing	20
Temperature Monitoring Using XTEMP Pin	21
Nonvolatile Memory and Security Features	21
Monitoring Through SMBus	21
PMBus Command Summary	22
PMBus Use Guidelines	25
PMBus Data Formats	26
PMBus Command Detail	27
MFR_SMBALERT_MASK (DBh)	70
Revision History	90
About Intersil	90
Package Outline Drawing	91

Two-Phase Application

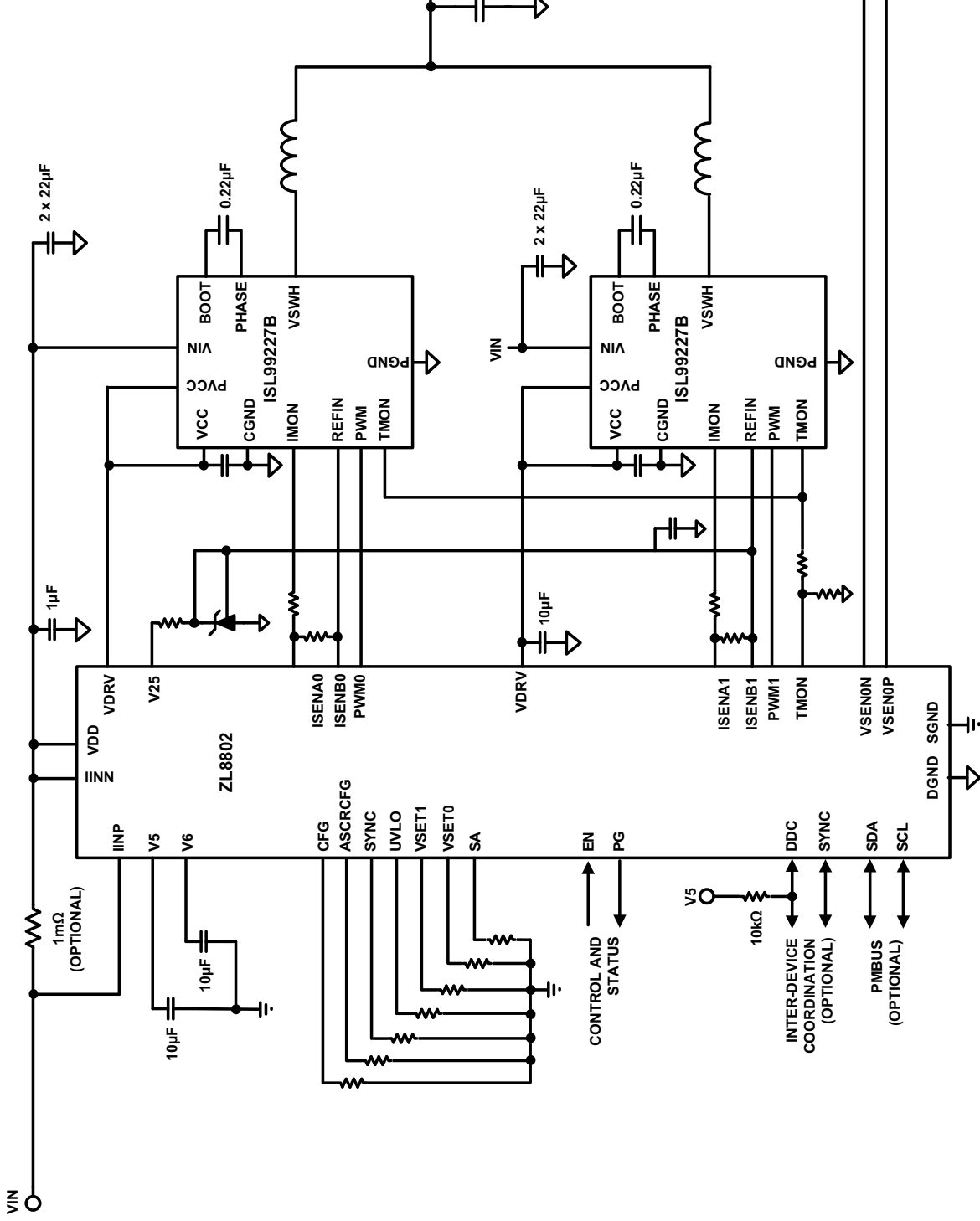

FIGURE 1. TWO-PHASE APPLICATION

Block Diagram

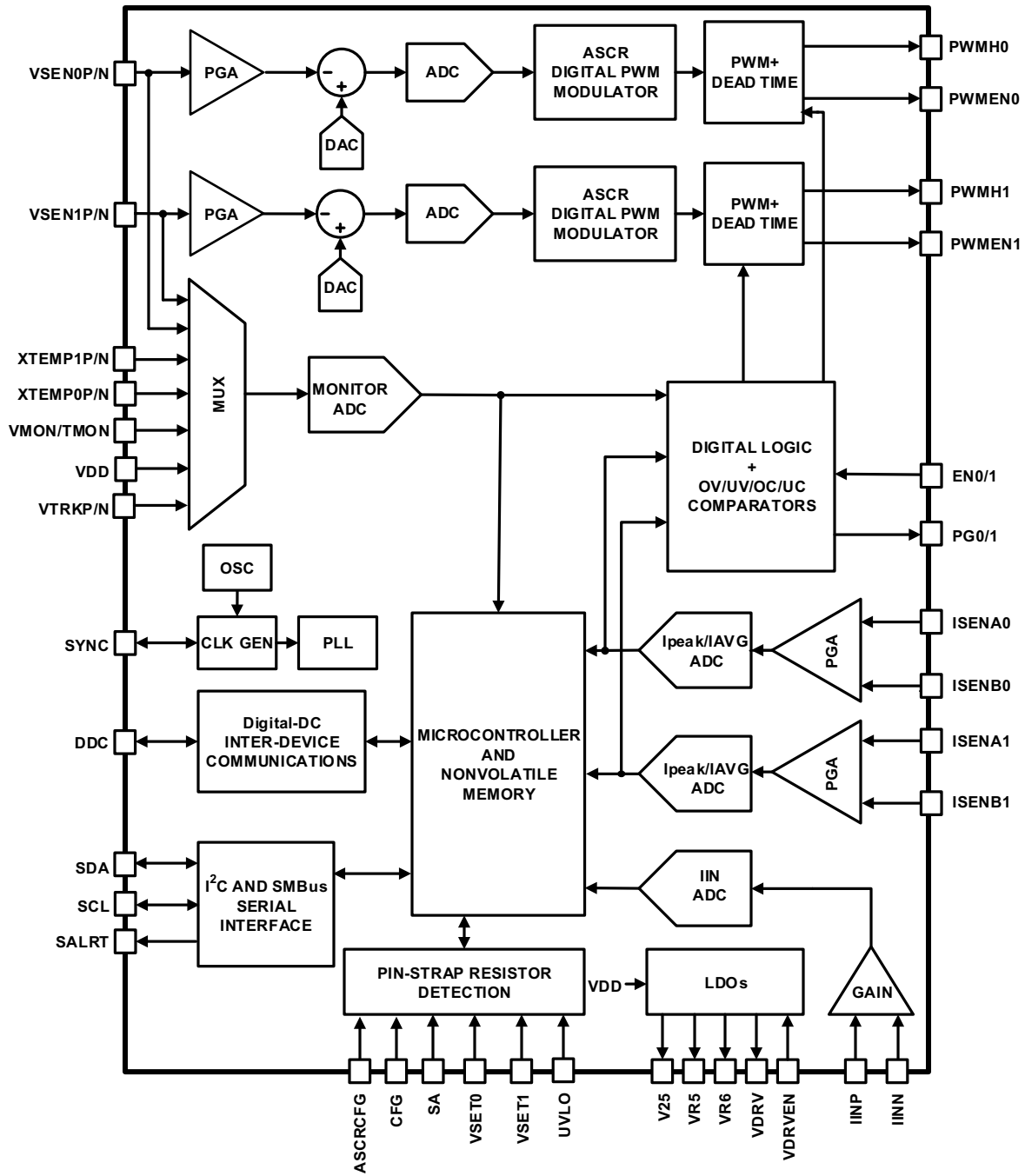
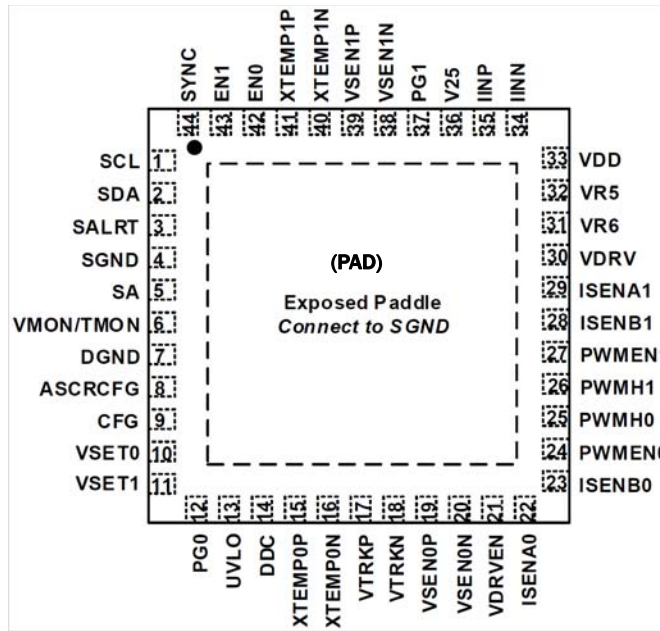

FIGURE 2. BLOCK DIAGRAM

Pin Configuration

ZL8802
(44 LD QFN)
TOP VIEW



Pin Description

PIN #	PIN NAME	TYPE (Note 1)	DESCRIPTION
1	SCL	I/O	Serial clock. Connect to external host and/or to other ZL devices. Requires a pull-up resistor to a 2.5V to 5.5V (VR5 recommended, do not use V25) source. Pull-up supply must be from an “always on” source or VR5.
2	SDA	I/O	Serial data. Connect to external host and/or to other ZL devices. Requires a pull-up resistor to a 2.5V to 5.5V (VR5 recommended, do not use V25) source. Pull-up supply must be from an “always on” source or VR5.
3	SALRT	O	Serial alert. Connect to external host if desired. Requires a pull-up resistor to a 2.5V to 5.5V (recommend VR5, do not use V25) source. Leave floating if not used.
4	SGND	PWR	Connect to low impedance ground plane. Internal connection to SGND. All pin-strap resistors should be connected to SGND. SGND must be connected to DGND and PGND using a single point connection.
5	SA	M	Serial address select pin. Used to assign unique address for each individual device. See Table 3 on page 12 for PMBus address options. Connect resistor to SGND.
6	VMON/TMON	I	Smart power stage temperature monitoring or general purpose voltage monitoring pin. Requires an external 2:1 resistor divider network to correctly read temperature. Requires an external 16:1 resistor divider network to read voltage. Connect bottom of resistor divider network to SGND. Connect VMON/TMON pin to SGND if not used.
7	DGND	PWR	Digital ground. Must connect to SGND and PGND using a single point connection.
8	ASRCFG	M	Selects ChargeMode control (ASCR) configuration settings. See “Configurable Pins” on page 12 and Table 8 on page 14 for details.
9	CFG	M	Selects current sense, current limit, and operating mode. See “Configurable Pins” on page 12 and Table 8 on page 14 for details.
10	VSET0	M	Channel 0 output voltage selection pin. Used to set V_{OUT0} and V_{OUT0} max. See Table 4 on page 12 for V_{OUT} pin-strap options. Default V_{OUT} max is 115% of V_{OUT} setting, but this can be overridden through the PMBus interface with the V_{OUT_MAX} command. Connect resistor to SGND.
11	VSET1	M	Channel 1 output voltage selection pin. Used to set V_{OUT1} and V_{OUT1} max. See Table 4 on page 12 for V_{OUT} pin-strap options. Default V_{OUT} max is 115% of V_{OUT} setting, but this can be overridden through the PMBus interface with the V_{OUT_MAX} command. Connect resistor to SGND. NOT USED IN 2-PHASE MODE. Leave floating in 2-phase mode.
12	PGO	O	Channel 0 Power-Good output. Can be configured as open-drain or push-pull using the PMBus interface. Default setting is open-drain.

Pin Description (Continued)

PIN #	PIN NAME	TYPE (Note 1)	DESCRIPTION
13	UVLO	M	Undervoltage lockout selection. Sets the minimum value for V_{DD} voltage to enable V_{OUT} . See Table 6 on page 13 for UVLO setting options. Pin-strapped (configured) values can be overridden by the PMBus interface. Connect resistor to SGND. If enabling the device by tying the EN0 and or EN1 pins high (self-enabling), set the UVLO level to 16V with a 100k resistor so the device will not turn on until after a configuration file has been loaded.
14	DDC	I/O	Single-wire DDC bus (current sharing, interdevice communication). Requires a pull-up resistor to a 2.5V to 5.5V (recommend VR5, do not use V25) source. Pull-up voltage must be present when the device is powered. Pull-up supply must be from an "always on" source or VR5.
15	XTEMP0P	I	External temperature sensor input for Channel 0. Connect to external 2N3904 (base emitter junction) or equivalent embedded thermal diode. If not used connect to SGND.
16	XTEMP0N	I	External temperature sensor input for Channel 0 return. If not used connect to SGND.
17	VTRKP	-	Tracking sense positive input. Used to track an external voltage source. Tracking is only possible in 2-phase operation, or with a single channel in a 2-channel configuration. Tracking is disabled in 4-, 6-, and 8-phase operation. If not used, connect to SGND.
18	VTRKN	-	Tracking sense negative input (return). If not used connect to SGND.
19	VSENO P	I	Differential output Channel 0 voltage sense feedback. Connect to positive output regulation point.
20	VSENO N	I	Differential output Channel 0 voltage sense feedback. Connect to negative output regulation point.
21	VDRVEN	I	VDRV (MOSFET Driver Bias Supply) enable. Leave unconnected (float) or pull up to VR5 to enable, tie to ground to disable.
22	ISENA0	I	Positive differential voltage input for Channel 0 DCR current sensing. Should be routed as a pair with ISENB0. Should connect to resistor located close to output inductor. See "SPS Current Sensing" on page 17 .
23	ISENB0	I	Negative differential voltage input for Channel 0 DCR current sensing. Should be routed as a pair with ISENA0. Should be connected to output inductor terminal. See "SPS Current Sensing" on page 17 .
24	PWMEN0	O	Used to drive DrMOS enable where applicable. Leave unconnected when not used.
25	PWMH0	O	PWM0 high signal.
26	PWMH1	O	PWM1 high signal.
27	PWMEN1	O	Used to drive DrMOS enable where applicable. Leave unconnected when not used.
28	ISENB1	I	Negative differential voltage input for Channel 1 DCR current sensing. Should be routed as a pair with ISENA1. Should be connected to output inductor terminal. See "SPS Current Sensing" on page 17 for details.
29	ISENA1	I	Positive differential voltage input for Channel 1 DCR current sensing. Should be routed as a pair with ISENB1. Should connect to resistor located close to output inductor. See "SPS Current Sensing" on page 17 for details.
30	VDRV	PWR	MOSFET driver bias supply regulator output. If disabled, this pin can be left floating. Decouple with a high quality 4.7 μ F X7R or better ceramic capacitor placed close to this pin.
31	VR6	PWR	Bypass for internal 6V reference used to power internal circuitry. Decouple with a high quality 4.7 μ F X7R or better ceramic capacitor placed close to this pin. Keep this net as small as possible. Do not route near switching signals.
32	VR5	PWR	Bypass for internal 5V reference used to power internal circuitry. Decouple with a high quality 4.7 μ F X7R or better ceramic capacitor placed close to this pin.
33	VDD	PWR	Supply voltage. Decouple with a high quality 1 μ F X7R or better ceramic capacitor placed close to this pin.
34	IINN	I	Input current monitor negative input. If not used connect to VDD.
35	IINP	I	Input current monitor positive input. If not used connect to VDD.
36	V25	PWR	Internal 2.5V reference used to power internal circuitry. Decouple with a high quality 4.7 μ F X7R or better ceramic capacitor placed close to this pin.
37	PG1	O	Channel 1 Power-Good output. Can be configured as open-drain or push-pull using the PMBus interface. Default setting is open-drain.
38	VSEN1N	I	Differential output Channel 1 voltage sense feedback. Connect to negative output regulation point. NOT USED IN 2-PHASE MODE. Leave floating in 2-phase mode.
39	VSEN1P	I	Differential output Channel 1 voltage sense feedback. Connect to positive output regulation point. NOT USED IN 2-PHASE MODE. Leave floating in 2-phase mode.
40	XTEMP1N	I	External temperature sensor input for Channel 1 return. If not used connect to SGND.
41	XTEMP1P	I	External temperature sensor input for Channel/Phase 1. Connect to external 2N3904 (base emitter junction) or equivalent embedded thermal diode. If not used connect to SGND.

Pin Description (Continued)

PIN #	PIN NAME	TYPE (Note 1)	DESCRIPTION
42	ENO	I	Enable Channel 0. Active signal enables PWM0 switching. Recommended to be tied low during device configuration. Refer to “Enable Pin Operation and Timing” on page 16 for additional information.
43	EN1	I	Enable Channel 1. Active signal enables PWM1 switching. Recommended to be tied low during device configuration. Refer to “Enable Pin Operation and Timing” on page 16 for additional information. NOT USED IN 2-PHASE MODE. When not used, we recommend connecting this pin to ground.
44	SYNC	M/I/O	Clock synchronization input. Used to set the frequency of the internal clock, to sync to an external clock or to output internal clock. When configured as an output this pin is push-pull and does not require a pull-up. See “Switching Frequency Setting (SYNC)” on page 12 and Table 5 on page 12 for additional information.
PAD	SGND	PWR	Exposed thermal pad. Connect to low impedance ground plane. Internal connection to SGND.

NOTE:

1. I = Input, O = Output, PWR = Power or Ground, M = Multimode pins.

Ordering Information

PART NUMBER (Notes 2, 3, 4)	PART MARKING	TEMP. RANGE (°C)	TAPE AND REEL QUANTITY (Units)	PACKAGE (RoHS Compliant)	PKG. DWG. #
ZL8802ALAFT	8802	-40 to +85	4k	44 Ld QFN	L44.7x7B
ZL8802ALAFT7A	8802	-40 to +85	250	44 Ld QFN	L44.7x7B
ZL8802ALAFTK	8802	-40 to +85	1k	44 Ld QFN	L44.7x7B

NOTES:

2. Refer to [TB347](#) for details on reel specifications.
3. These Pb-free plastic packaged products employ special Pb-free material sets, molding compounds/die attach materials, and 100% matte tin plate plus anneal (e3 termination finish, which is RoHS compliant and compatible with both SnPb and Pb-free soldering operations). Pb-free products are MSL classified at Pb-free peak reflow temperatures that meet or exceed the Pb-free requirements of IPC/JEDEC J STD-020.
4. For Moisture Sensitivity Level (MSL), refer to the product information page for the [ZL8802](#). For more information on MSL, refer to [TB363](#).

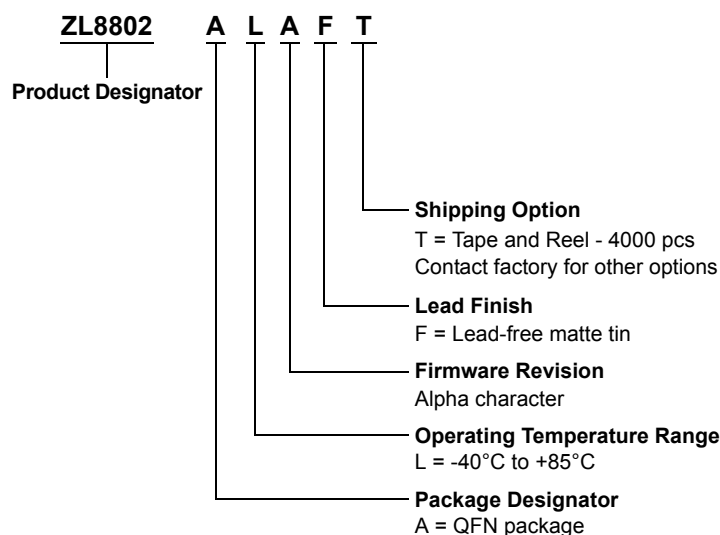

Absolute Maximum Ratings

DC Supply Voltage: VDD	-0.3V to 17V
Logic I/O Voltage: DDC, EN0, EN1, PG0, PG1, SA, VDRVEN, SALRT, SCL, SDA, SYNC, UVLO, VMON/TMON, VSET0, VSET1, CFG, ASCRCFG	-0.3V to 6.0V
Analog Input Voltages: VSEN0P, VSEN0N, VSEN1P, VSEN1N, ISENA0, ISENA1, ISENB0, ISENB1	-0.3V to 6.5V
XTEMP0P, XTEMP1P	-0.3V to 6.0V
XTEMP0N, XTEMP1N	-0.3V to 0.3V
IINN, IINP	-0.3V to 17V
Logic Reference: V25	-0.3V to 3V
Bias Supplies: VR5, VR6, VDRV	-0.3V to 6.5V
PWM Logic Outputs, PWMH0, PWMH1, PWML0, PWML1	-0.3V to 6.5V
Ground Voltage Differential (VDGND-VSGND)	-0.3V to +0.3V
ESD Ratings	
Human Body Model (Tested per JESD22-A114E)	3000V
Machine Model (Tested per JESD22-A115-A)	200V
Charged Device Model (Tested per JESD22-C1010-D)	1000V
Latch-Up (Tested per JESD78C; Class 2, Level A)	100mA

Thermal Information

Thermal Resistance (Typical)	θ_{JA} (°C/W)	θ_{JC} (°C/W)
44 Ld QFN Package (Notes 6, 7)	25	1.5
Junction Temperature	-55°C to +150°C	
Storage Temperature Range	-55°C to +150°C	
Pb-Free Reflow Profile	see TB493	

Recommended Operating Conditions

Input Supply Voltage Range, VDD	4.5V to 14V
Output Voltage Range, VOUT	0.54V to 5.5V
Operating Junction Temperature Range, T _J	-40°C to +125°C
Ambient Temperature Range, T _A	-40°C to +85°C
5V (VR5) Supply Total Supplied Current (Note 8)	5mA
5V LDO Supply (VDRV) (Note 5)	0 to 80mA

CAUTION: Do not operate at or near the maximum ratings listed for extended periods of time. Exposure to such conditions may adversely impact product reliability and result in failures not covered by warranty.

NOTES:

- Output current is limited by device thermal dissipation.
- θ_{JA} is measured in free air with the component mounted on a high-effective thermal conductivity test board with "direct attach" features. See [TB379](#).
- For θ_{JC} , the "case temp" location is the center of the exposed metal pad on the package underside.
- Total of current used by pull-ups to SDA, SCL, SALRT, DDC, EN, and PG (including push-pull configuration).

Electrical Specifications

V_{DD} = 12V. Typical values are at T_A = +25°C. Boldface limits apply across the operating ambient temperature range, T_A -40°C to +85°C

PARAMETER	TEST CONDITIONS	MIN (Note 14)	TYP	MAX (Note 14)	UNIT
IC INPUT AND BIAS SUPPLY CHARACTERISTICS					
IDD Supply Current	f _{SW} = 200kHz	-	26	50	mA
	f _{SW} = 1.33MHz	-	50	80	mA
IDD Device Disabled Current	EN = 0V, SMBus inactive, VDD = 12V, f _{SW} = 1.33MHz	-	20	40	mA
VR5 Reference Output Voltage	VDD > 6V, I < 5mA	4.5	5.0	5.5	V
V25 Reference Output Voltage	For reference only, VR > 3V	2.25	2.5	2.75	V
VR6 Reference Output Voltage	For reference only, VDD = 12V	5.5	6.1	6.6	V
VDRV 5V Output Voltage (Note 9)	V _{DD} > 6.0V; 0 to 80mA	4.5	5.25	5.5	V
OUTPUT CHARACTERISTICS					
Output Voltage Adjustment Range	V _{IN} > V _{OUT} + 1.1V	0.54	-	5.5	V
Output Voltage Set-point Accuracy (Note 11)	Across line, load, temperature variation 0.72 < V _{OUT} < 5.50	-1	-	1	% V _{OUT}
Output Voltage Set-point Resolution (Note 10)	Set using PMBus command	-	±0.025	-	% V _{OUT}
Output Voltage Positive Sensing Bias Current	VSEN[0,1] P = 4V (negative = sinking)	-100	20	100	µA
Output Voltage Negative Sensing Bias Current	VSEN[0,1] N = 0V	-	20	-	µA
LOGIC INPUT/OUTPUT CHARACTERISTICS					
Logic Input Leakage Current	Logic I/O - multimode pins	-100	-	100	nA
Logic Input Low, V _{IL}		-	-	0.8	V
Logic Input High, V _{IH}		2	-	-	V
Logic Output Low, V _{OL}	2mA sinking	-	-	0.5	V
Logic Output High, V _{OH}	2mA sourcing	2.25	-	-	V

Electrical Specifications $V_{DD} = 12V$. Typical values are at $T_A = +25^\circ C$. **Boldface limits apply across the operating ambient temperature range, $T_A -40^\circ C$ to $+85^\circ C$** (Continued)

PARAMETER	TEST CONDITIONS	MIN (Note 14)	TYP	MAX (Note 14)	UNIT
PWM OUTPUT CHARACTERISTICS					
PWM Output Low	2mA sinking	-	-	0.5	V
PWM Output High	2mA sourcing	4.25	-	-	V
PWM Tri-State Input Bias Current (PWMHO, 1)	$V_{PWM} = 2.5V$	-	-	10	μA
PWM Tri-State Transition (Always Starts from LOW)	10pF Maximum Load		1		μs
OSCILLATOR AND SWITCHING CHARACTERISTICS					
Switching Frequency Range		200	-	1334	kHz
Switching Frequency Set-point Accuracy		-5	-	5	%
Minimum SYNC Pulse Width	50% to 50%	150	-	-	ns
Input Clock Frequency Drift Tolerance	Maximum allowed drift of external clock	-10	-	10	%
PMBus Clock Frequency (Note 12)		100	-	400	kHz
POWER MANAGEMENT					
SOFT START/RAMP CHARACTERISTICS					
Ton-delay/Toff-Delay Range	Set using PMBus command	0		5000	ms
Ton-Delay Accuracy	2-phase Ton-Delay > 4ms	-	+/-1	-	ms
Toff-Delay Accuracy	Set to immediate off		-0/+1		ms
Ton-Rise/Toff-Fall Duration Range	Set using PMBus command (2-phase or 2-channel only)	0.0		100	ms
Ton-Rise/Toff-Fall Duration Accuracy	2-phase or 2-channel only	-	± 250	-	μs
MONITORING AND FAULT MANAGEMENT					
INPUT VOLTAGE MONITOR AND FAULT DETECTION					
VDD/VIN UVLO Threshold Range		2.85	-	16	V
VDD/VIN Monitor Accuracy	Full Scale (FS) = 14V	-	± 2	-	% FS
VDD/VIN Monitor Resolution	Full Scale (FS) = 14V	-	± 0.15	-	% FS
VIN UV Fault Response Delay		-	100	-	μs
INPUT CURRENT					
Input Current Sense Differential Input Voltage	$V_{IINP} - V_{IINN}$	0	-	20	mV
Input Current Sense Input Offset Voltage	$V_{IINP} - V_{IINN}$	-	± 100	-	μV
Input Current Sense Accuracy	% of Full Scale (20mV)	-	± 5	-	% FS
OUTPUT VOLTAGE MONITOR AND FAULT DETECTION					
VOUT Monitor Accuracy	FS = V_{SET} voltage (VOUT)	-2	-	2	% FS
VOUT Monitor Resolution	FS = V_{SET} voltage (VOUT)	-	± 0.15	-	% FS
VOUT UV Fault Response Delay		-	10	-	μs
OUTPUT CURRENT					
OUTPUT CURRENT SENSE RESOLUTION					
Low Range	$\pm 25mV$ Full Scale	-	37.5	-	μV
Medium Range	$\pm 35mV$ Full Scale	-	56.25	-	μV
High Range	$\pm 50mV$ Full Scale	-	75.0	-	μV
OUTPUT CURRENT SENSE INPUT BIAS CURRENT					
VOUT Referenced	ISENA0 or ISENA1	-100	-	100	nA
	ISENB0 or ISENB1	-25	-	25	μA
OUTPUT CURRENT SENSE MONITOR AND FAULT DETECTION					
Output Current DCR Monitor Temperature Compensation	Configurable through PMBus	0		12700	ppm/ $^\circ C$

Electrical Specifications $V_{DD} = 1.2V$. Typical values are at $T_A = +25^\circ C$. **Boldface limits apply across the operating ambient temperature range, $T_A -40^\circ C$ to $+85^\circ C$** (Continued)

PARAMETER	TEST CONDITIONS	MIN (Note 14)	TYP	MAX (Note 14)	UNIT
TMON BIAS MONITOR AND FAULT DETECTION					
TMON UVLO Threshold Range	Using TMON pin with 16:1 resistor divider	2.85	-	5	V
TMON Accuracy (Note 13)	Full Scale (FS) = 1.15V	-2	-	2	% FS
TMON Resolution	Full Scale (FS) = 1.15V	-	± 0.15	-	% FS
TMON UV/OV Fault Response Delay		-	200	-	μs
TEMPERATURE SENSING					
INTERNAL TEMPERATURE SENSOR					
Internal Temperature Accuracy	Tested at $+100^\circ C$	-5	-	5	$^\circ C$
Internal Temperature Resolution		-	1	-	$^\circ C$
Thermal Protection Threshold (Junction temperature)	Factory default	-	125	-	$^\circ C$
	Configurable through PMBus	-40	-	125	$^\circ C$
EXTERNAL TEMPERATURE SENSOR: XTEMPO AND XTEMP1					
External Temperature Accuracy	Filter capacitance $<100pF$	-	± 5	-	$^\circ C$
External Temperature Resolution		-	1	-	$^\circ C$
Thermal Protection Threshold	Factory default	-	125	-	$^\circ C$
	Configurable through PMBus	-40	-	125	$^\circ C$

NOTES:

9. Output current is limited by device thermal dissipation.
10. Percentage of Full Scale (FS) with temperature compensation applied.
11. V_{OUT} measured at the termination of the VSENxP and VSENxN sense points.
12. For operation at 400kHz, see PMBus Power System Management Protocol Specification Part 1, Section 5.2.6.2 for timing parameter limits.
13. Does not include errors due to resistor divider tolerances.
14. Compliance to datasheet limits is assured by one or more methods: production test, characterization, and/or design.

ZL8802 Overview

Digital-DC Architecture Overview

The ZL8802 is an innovative mixed-signal power conversion and power management IC based on Intersil's patented Digital-DC technology that provides an integrated, high performance step-down converter for a wide variety of power supply applications.

The ZL8802 DC/DC controller is a dual channel, dual phase controller based on an architecture that does not require loop compensation.

The ZL8802's full digital loop achieves precise control of the entire power conversion process with no software required resulting in a very flexible device that is also very easy to use. The ChargeMode control algorithm is implemented to respond to output current changes within a single PWM switching cycle. This achieves a smaller total output voltage variation with less output capacitance than traditional PWM controllers. An extensive set of power management functions are fully integrated and can be configured using simple pin connections. The user configuration can be saved in an internal Nonvolatile Memory (NVRAM). Additionally, all functions can be configured and monitored through the SMBus hardware interface using standard PMBus commands, allowing ultimate flexibility. The ZL8802 is compliant with the PMBus Power System Management Protocol Specification Part I and II version 1.2.

When enabled, the ZL8802 is immediately ready to regulate power and perform power management tasks with no programming required. Advanced configuration options and real-time configuration changes are available through PMBus commands if desired and continuous monitoring of multiple operating parameters is possible with minimal interaction from a host controller. Integrated subregulation circuitry enables single supply operation from any supply between 4.5V and 14V with no bias supplies needed.

The ZL8802 can be configured by simply connecting its pins according to the tables provided in the following sections. Additionally, a comprehensive set of online tools and application notes are available to help simplify the design process. An evaluation board is also available to help the user become familiar with the device. This board can be evaluated as a standalone platform using pin configuration settings. PowerNavigator™, a Windows based GUI, is also provided to enable full configuration and monitoring capability through the PMBus interface and the included USB cable.

Power Management Overview

The ZL8802 incorporates a wide range of configurable power management features that are simple to implement with no external components. Additionally, the ZL8802 includes circuit protection features that continuously safeguard the device and load from damage due to unexpected system faults. The ZL8802 can continuously monitor input voltage and current, output voltage and current, internal temperature, and the temperature of two external thermal diodes. A Power-Good output signal is also included to enable power-on reset functionality for an external processor.

All power management functions can be configured using either pin configuration techniques described in this document or through the SMBus interface using PMBus commands. Monitoring parameters can also be preconfigured to provide alerts for specific conditions. The [“PMBus Command Summary” on page 22](#) contains a listing of all the PMBus commands supported by the ZL8802 and a detailed description of the use of each of these commands.

Pin-Strap Pins

To simplify circuit design, the ZL8802 incorporates patented pin-strap pins that allow the user to easily configure many aspects of the device with no programming. Most power management features can be configured using these pins. The pin-strap pins will read the value of the resistor connected to those pins when power is applied to the device and set certain device configuration settings as specified by those resistor values.

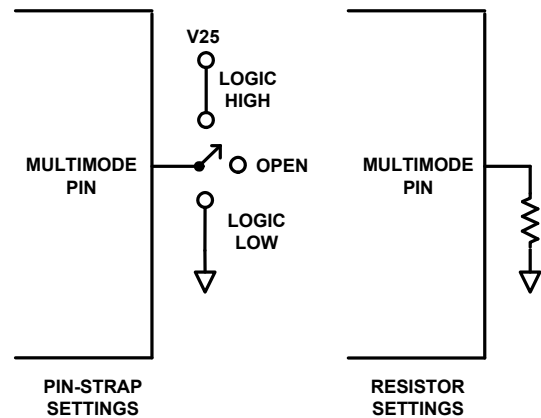

FIGURE 3. PIN-STRAP AND RESISTOR SETTINGS

TABLE 2.

PIN TIED TO	VALUE
LOW (Logic LOW)	<0.8 VDC
OPEN (N/C)	No connection
HIGH (Logic HIGH)	>2.0 VDC
Resistor to SGND	Set by resistor value

Device configuration settings are made when connecting a finite value resistor (in a specified range) between the pin-strap pin and SGND. Standard 1% resistor values are used, and only every fourth E96 resistor value is used so the device can reliably recognize the value of resistance connected to the pin while eliminating the error associated with the resistor accuracy. Up to 31 unique selections are available using a single resistor.

SMBus: Almost any ZL8802 function can be configured through the SMBus interface using standard PMBus commands. Additionally, any value that has been configured using the pin-strap setting method can also be reconfigured and/or verified through SMBus. [“PMBus Command Detail” on page 27](#) explains the use of the PMBus commands in detail.

Configurable Pins

Numerous operating parameters can be set using the pin-strap resistor setting method: SMBus address (pin 5, SA), output voltage (pins 10 and 11, VSET0, 1), switching frequency (pin 44, SYNC), input voltage undervoltage lockout (pin 13, UVLO). ASCR gain is set by ASCRCFG (pin 8). CFG (pin 9) sets the power stage settings such as over and undercurrent limits.

The SMBus device address is the only parameter that **must** be set by a pin-strap setting pin. All other device parameters can be set through PMBus. The device address is set using the SA pin.

SMBus Device Address Selection (SA)

When communicating with multiple SMBus devices using the SMBus interface, each device must have its own unique address so the host can distinguish between the devices. The device address can be set according to the pin-strap options listed in [Table 3](#). When operating in 2-channel mode, care must be taken when using sequential PMBus addresses. Because DDC addresses are automatically set using the PMBus address, it is possible for a device with a PMBus address immediately after a 2-channel ZL8802 to be automatically configured with the same DDC address as one of the ZL8802 channels, which could cause unintended operating modes. For this reason, do not use the next higher PMBus address when using the ZL8802 as a 2-channel device. See PMBus command “[DDC_CONFIG \(D3h\)](#)” on [page 65](#) for details. The SMBus address cannot be changed with a PMBus command.

TABLE 3. SMBUS DEVICE ADDRESS SELECTION

RSA (kΩ)	SMBus ADDRESS	RSA (kΩ)	SMBus ADDRESS
LOW	40h	42.2	51h
OPEN	42h	46.4	52h
10	41h	51.1	53h
11	43h	56.2	54h
12.1	44h	61.9	55h
13.3	45h	68.1	56h
14.7	46h	75	57h
16.2	47h	82.5	58h
17.8	48h	90.9	59h
19.6	49h	100	5Ah
21.5	4Ah	110	5Bh
23.7	61h	121	5Ch
26.1	4Ch	133	5Dh
28.7	4Dh	147	5Eh
31.6	4Eh	162	5Fh
34.8	4Fh	178	60h
38.3	50h		

Output Voltage and VOUT_MAX Selection (VSET0, 1)

The output voltage can be set to any voltage between 0.54V and 5.5V provided that the input voltage is higher than the desired output voltage by at least 1.1V. Using the pin-strap method, V_{OUT} can be set to any of the voltages shown in [Table 4](#). V_{OUT} can also be set using a PMBus command. VOUT_MAX is also determined by this pin-strap setting, and is 15% greater than the VSET0 and VSET1 voltage settings by default, however, VOUT_MAX can be changed through PMBus.

TABLE 4. OUTPUT VOLTAGE SETTINGS

RVSET (kΩ)	VOUT (V)	RVSET (kΩ)	VOUT (V)
LOW	1.00	38.3	1.30
OPEN	1.20	42.2	1.40
HIGH	0.90	46.4	1.50
10	0.60	51.1	1.60
11	0.65	56.2	1.70
12.1	0.70	61.9	1.80
13.3	0.75	68.1	1.90
14.7	0.80	75	2.00
16.2	0.85	82.5	2.10
17.8	0.90	90.9	2.20
19.6	0.95	100	2.30
21.5	1.00	110	2.50
23.7	1.05	121	2.80
26.1	1.10	133	3.00
28.7	1.15	147	3.30
31.6	1.20	162	4.00
34.8	1.25	178	5.00

Switching Frequency Setting (SYNC)

The device's switching frequency is set from 200kHz to 1333kHz using the pin-strap method as shown in [Table 5](#), or by using a PMBus command. The ZL8802 generates the device switching frequency by dividing an internal precision 16MHz clock by integers from 11 to 80.500kHz (n = 32) and 1000kHz (n = 16) are not recommended operating frequencies; use 533kHz and 1067kHz for best performance.

TABLE 5. SWITCHING FREQUENCY SETTINGS

RSYNC (kΩ)	FREQ (kHz)	RSYNC (kΩ)	FREQ (kHz)
LOW	302	23.7	457
OPEN	400	26.1	533
HIGH	485	28.7	571
10	200	31.6	615
11	222	34.8	727
12.1	242	38.3	800

TABLE 5. SWITCHING FREQUENCY SETTINGS (Continued)

RSYNC (kΩ)	FREQ (kHz)	RSYNC (kΩ)	FREQ (kHz)
13.3	267	42.2	842
14.7	286	46.4	889
16.2	320	51.1	1067
17.8	364	56.2	1143
19.6	381	61.9	1231
21.5	432	68.1	1333

The ZL8802 incorporates an internal Phase-Locked Loop (PLL) to clock the internal circuitry. The PLL can be driven by an external clock source connected to the SYNC pin. When using the internal oscillator, the SYNC pin can be configured as a clock source for other Intersil digital power devices.

By default, the SYNC pin is configured as an input. The device will automatically check for a clock signal on the SYNC pin each time EN is asserted. The ZL8802's oscillator will then synchronize with the rising edge of the external clock.

The incoming clock signal must be in the range of 200kHz to 1.33MHz and must be stable when the enable pin (ENO, EN1) is asserted. When using an external clock, the frequencies are not limited to discrete values as when using the internal clock. The external clock signal must not vary more than 10% from its initial value and should have a minimum pulse width of 150ns. In the event of a loss of the external clock signal, the output voltage may show transient overshoot or undershoot.

If loss of synchronization occurs, the ZL8802 will automatically switch to its internal oscillator and switch at its programmed frequency.

When used in a multiphase (4-, 6-, and 8-phase) application, the SYNC pin of one of the devices must be configured as an output. The device will run from its internal oscillator and will drive the SYNC pin so other devices can be synchronized to it. The SYNC pin will not be checked for an incoming clock signal while in this mode.

The switching frequency can be set to any value between 200kHz and 1.33MHz using a PMBus command. The available frequencies below 1.33MHz are defined by $f_{SW} = 16\text{MHz}/N$, where $12 \leq N \leq 80$.

If a value other than $f_{SW} = 16\text{MHz}/N$ is entered using a PMBus command, the internal circuitry will select the switching frequency value using N as a whole number to achieve a value close to the entered value. For example, if 810kHz is entered, the device will select 800kHz ($N = 20$).

Input Voltage Undervoltage Lockout Setting (UVLO)

The input Undervoltage Lockout (UVLO) prevents the ZL8802 from operating when the input falls below a preset threshold, indicating the input supply is out of its specified range. The input voltage undervoltage lockout threshold can be set between 4.18V and 16V using the pin-strap method as shown in Table 6. UVLO can also be set or changed using the VIN_UV_FAULT_LIMIT command.

TABLE 6. INPUT VOLTAGE UNDERVOLTAGE LOCKOUT SETTING

RUVLO (kΩ)	UVLO (V)	RUVLO (kΩ)	UVLO (V)
LOW	5.50	46.4	7.42
OPEN	4.50	51.1	8.18
HIGH	10.80	56.2	8.99
26.1	4.18	61.9	9.90
28.7	4.59	68.1	10.90
31.6	5.06	75	12.00
34.8	5.57	82.5	13.20
38.3	6.13	90.9	14.54
42.2	6.75	100	16.00

When an input undervoltage fault condition occurs, the user can determine the desired response to the fault condition. The following input undervoltage protection response options are available:

- Shut down and stay off until the fault has cleared and the device has been disabled and reenabled.
- Shut down and restart continuously after a delay.

Refer to "[PMBus Command Detail](#)" on page 27 for details on how to select specific overvoltage fault response options using the VIN_UV_FAULT_RESPONSE command.

When controlling the ZL8802 exclusively through the PMBus, a high voltage setting for UVLO can be used to prevent the ZL8802 from being enabled until a lower voltage for UVLO is set using the VIN_UV_FAULT_LIMIT command.

Configuration Setting (CFG)

The Configuration pin (CFG) sets several device configuration settings allowing the device to be used in applications without the need for loading configuration files. The settings are shown in Table 7. When using the ZL8802 in a 4-phase application, the master device address must be 1 higher than the slave address. This must be done for the two devices to be recognized as part of a current sharing group. See PMBus command "[DDC_CONFIG \(D3h\)](#)" on page 65 for details.

TABLE 7. CONFIGURATION SETTINGS

RCFG (kΩ)	Page 0		Page 1		CIRCUIT
	AVERAGE OC LIMIT (A)	PEAK OC LIMIT (A)	AVERAGE OC LIMIT (A)	PEAK OC LIMIT (A)	
10	25	28	25	28	2 Output
11	35	37.5	35	37.5	2 Output
12.1	45	48	45	48	2 Output
13.3	55	60	55	60	2 Output
14.7	60	65	60	65	2 Output
16.2	65	70	65	70	2 Output
17.8	35	37.5	25	28	2 Output
19.6	45	48	25	28	2 Output
21.5	55	60	25	28	2 Output
23.7	45	48	35	37.5	2 Output

TABLE 7. CONFIGURATION SETTINGS (Continued)

RCFG (kΩ)	Page 0		Page 1		CIRCUIT
	AVERAGE OC LIMIT (A)	PEAK OC LIMIT (A)	AVERAGE OC LIMIT (A)	PEAK OC LIMIT (A)	
26.1	55	60	35	37.5	2 Output
28.7	55	60	45	48	2 Output
31.6	25	28	35	37.5	2 Output
34.8	25	28	45	48	2 Output
38.3	25	28	55	60	2 Output
42.2	35	37.5	45	48	2 Output
46.4	35	37.5	55	60	2 Output
51.1	45	48	55	60	2 Output
56.2	25	28	25	28	2-Phase
61.9	35	37.5	35	37.5	2-Phase
68.1	45	48	45	48	2-Phase
75	55	60	55	60	2-Phase
82.5	65	70	65	70	2-Phase
90.9	35	37.5	35	37.5	4-PH Master
100	35	37.5	35	37.5	4-PH Slave
110	45	48	45	48	4-PH Master
121	45	48	45	48	4-PH Slave
133	55	60	55	60	4-PH Master
147	55	60	55	60	4-PH Slave
162	65	70	65	70	4-PH Master
178	65	70	65	70	4-PH Slave
LOW	20	22.5	20	22.5	2-Phase
OPEN	20	22.5	20	22.5	2 Output
HIGH	35	37.5	35	37.5	2 Output

ChargeMode Control (ASCR) Setting (ASCRCFG)

The device's ChargeMode response can be optimized by adjusting the ASCR gain and residual settings, either by using the ASCRCFG pin-strap resistor method as shown in [Table 8](#), or by using the ASCR_CONFIG PMBus command. When using [Table 8](#), the ASCR Residual is fixed at 90.

TABLE 8. ChargeMode CONTROL (ASCR) SETTINGS

ASCRCFG (kΩ)	GAIN P0	GAIN P1	ASCRCFG (kΩ)	GAIN P0	GAIN P1
10	200	200	51.1	800	600
11	200	400	56.2	800	800
12.1	200	600	61.9	800	1000
13.3	200	800	68.1	1000	200
14.7	200	1000	75	1000	400

TABLE 8. ChargeMode CONTROL (ASCR) SETTINGS (Continued)

ASCRCFG (kΩ)	GAIN P0	GAIN P1	ASCRCFG (kΩ)	GAIN P0	GAIN P1
16.2	400	200	82.5	1000	600
17.8	400	400	90.9	1000	800
19.6	400	600	100	1000	1000
21.5	400	800	110	100	100
23.7	400	1000	121	300	300
26.1	600	200	133	500	500
28.7	600	400	147	700	700
31.6	600	600	162	900	900
34.8	600	800	178	1100	1100
38.3	600	1000	LOW	300	300
42.2	800	200	OPEN	500	500
46.4	800	400	HIGH	700	700

Start-Up and Shutdown Settings

The device's start-up and shutdown settings can be set by using the following PMBus Commands:

TON_DELAY: Sets the time from a low to high EN0 or EN1 transition, or the receipt of an OPERATION command through PMBus, to the start of an output voltage ramp.

TON_RISE: Sets the time from the end of the TON_DELAY to the output voltage reaching regulation.

TOFF_DELAY: Sets the time from a high to low EN0 or EN1 transition, or the receipt of an OPERATION command through PMBus, to the start of an output voltage ramp down.

TOFF_FALL: Sets the time from the end of the TOFF_DELAY to the output voltage reaching 0V.

Note that in the case of 2-channel operation, these settings will apply to both channels. Each channel can be configured to have different settings by using the TON_DELAY, TON_RISE, TOFF_DELAY, and TOFF_FALL PMBus commands.

Internal Bias Regulators and Input Supply Connections

The ZL8802 employs internal Low Dropout (LDO) regulators to supply bias voltages for internal circuitry, allowing it to operate from a single input supply. The internal bias regulators are as follows:

VR6: The VR6 LDO provides a regulated 6.1V bias supply for internal circuitry. It is powered from the VDD pin. A 4.7μF ceramic X7R filter capacitor to SGND is required at the VR6 pin. Keep this net as small as possible and avoid routing this trace near any switching signals.

VR5: The VR5 LDO provides a regulated 5.1V bias supply for internal circuitry. It is powered from the VDD pin. A 4.7μF ceramic X7R filter capacitor to SGND is required at the VR5 pin. This supply can be used for to provide a pull-up supply as long as load current does not exceed 5mA.

V25: The V25 LDO provides a regulated 2.5V bias supply for the main controller circuitry. It is powered from an internal 5V node. A 4.7µF ceramic X7R filter capacitor to SGND is required at the V25 pin. This voltage should only be used to set pin-strap pins to the HIGH state.

VDRV: The VDRV LDO provides a regulated 5.25V bias supply for external MOSFET driver ICs or DrMOS integrated drivers/FETs. A 4.7µF ceramic X7R filter capacitor to PGND is required, however, additional capacitance will be needed as specified by the MOSFET driver or DrMOS device selected. The maximum rated output current is 80mA, but device thermal limits must be considered. The power dissipated by the VDRV supply will be $(V_{IN}-5.25V) \times I_{DRV}$, where I_{DRV} is the current supplied by the VDRV bias supply. VDRV is enabled by leaving the VDRVEN unconnected (floating) or connecting it to VR5, and is disabled by connecting VDRVEN to ground.

NOTE: The internal bias regulators, VR6, VR5, and V25, are not designed to be outputs for powering other circuitry. The multimode pins can be connected to the V25 pin for logic HIGH settings, and the VR5 supply can be used to provide up to 5mA of pull-up current for the SDA, SCL, SALRT, DDC, and PG pins.

Operation with 5V VDD: When operating the ZL8802 at voltages below 5.5V, the VR6 and VR5 supplies should be connected directly to VDD for best performance. The VDRV supply should not be used; the 5V VDD supply should be used instead for powering DrMOS and MOSFET driver ICs.

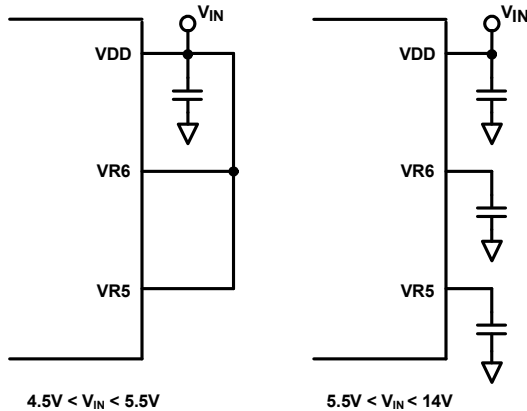

FIGURE 4. VR SUPPLY CONNECTIONS

Start-Up Procedure

The ZL8802 follows a specific internal start-up procedure after power is applied to the VDD pin, as shown in [Figure 5](#).

The device requires approximately 60ms to check for specific values stored in its internal memory. If the user has stored values in memory, those values will be loaded.

When this process is completed, the device is ready to accept commands through the serial interface and the device is ready to be enabled. If the device is to be synchronized to an external clock source, the clock frequency must be stable before asserting the EN pin. When enabled, the device requires approximately 2ms before its output voltage will be allowed to start its ramp-up process.

After the Ton-delay period has expired, the output will begin to ramp towards its target voltage according to the preconfigured Ton-rise time.

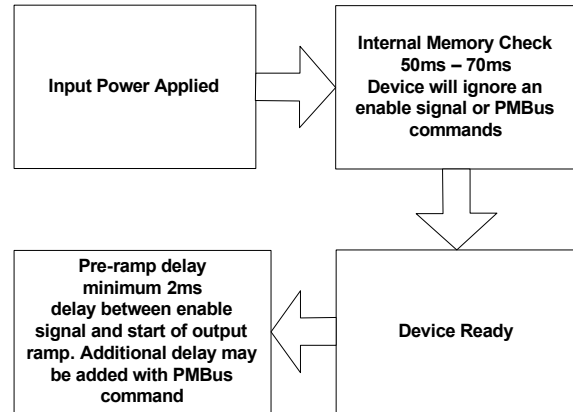

FIGURE 5. ZL8802 INTERNAL START-UP PROCEDURE

V_{IN} should be above the ZL8802’s UVLO limit (VIN_UV_FAULT_LIMIT) before the Enable pin is driven high.

Following this sequence will result in the most consistent turn-on delays. **If a configuration file is needed to ensure proper circuit operation**, when V_{IN} is first applied to the ZL8802, for example, during initial PCB turn-on and test, the Enable pin must be held low by some means until the ZL8802 configuration file can be loaded. If the Enable pin is not held low, then the ZL8802 may attempt to turn on with incorrect configuration settings, possibly causing circuit failure.

In those cases in which a configuration file is needed to ensure proper circuit operation and the Enable pin cannot be held low during the initial application of power, two options are available:

- Limit V_{IN} to 3.0V during initial testing. The ZL8802 configuration file can be loaded when V_{IN} is as low as 3.0V. When the configuration file is loaded V_{IN} can be increased to the normal input voltage range.
- Use a 100kΩ pin-strap resistor to set UVLO to 16V. This will keep the ZL8802 disabled while the configuration file is loaded. Ensure that the VIN_UV_FAULT_LIMIT command is the last command in the configuration file.

Ton-Delay and Rise Times

Ton- and Toff-delay and Ramp times are initially set to 5ms. In some applications, it may be necessary to set a delay from when an enable signal is received until the output voltage starts to ramp to its target value. In addition, the designer may wish to precisely set the time required for V_{OUT} to ramp to its target value after the delay period has expired. These features can be used as part of an overall inrush current management strategy or to precisely control how fast a load IC is turned on. The ZL8802 gives the system designer several options for precisely and independently controlling both the delay and ramp time periods.

The Ton-delay time begins when the EN pin is asserted. The Ton-delay time is set using the PMBus command TON_DELAY.

The Ton-rise time enables a precisely controlled ramp to the nominal V_{OUT} value that begins when the Ton-delay time has

expired. The ramp-up is monotonic and its slope can be precisely set using the PMBus command TON_RISE.

The Ton-delay and Ton-ramp times can be set using PMBus commands TON_DELAY and TON_RISE over the serial bus interface. When the Ton-delay time is set to 0ms, the device will begin its ramp after the internal circuitry has initialized

The Ton-delay and Ton-ramp times can be set using PMBus commands TON_DELAY and TON_RISE over the serial bus interface. When the Ton-delay time is set to 0ms, the device will begin its ramp after the internal circuitry has initialized which takes approximately 2ms to complete. The Ton-rise time can be set to values less than 2ms; however, the Ton-rise time should be set to a value greater than 500µs to prevent inadvertent fault conditions due to excessive inrush current. A lower Ton-rise time limit can be estimated using the formula: $Ton\text{-}rise = C_{OUT} * V_{OUT} / I_{LIMIT}$ where C_{OUT} is the total output capacitance, V_{OUT} is the output voltage, and I_{LIMIT} is the current limit setting for the ZL8802.

When using interdevice current sharing (4 phases), the output voltage rise time varies by application. The rise time can be adjusted using the PMBus command MULTI_PHASE_RAMP_GAIN. Higher gain values produce faster turn-on ramps. Typical MULTI_PHASE_RAMP_GAIN values range between 1 and 10; the default value is 3. The slew rate of the output voltage during ramp-up is directly proportional to this gain, as well as the input voltage (V_{IN}) and the device switching frequency (FREQUENCY_SWITCH). Use the following formula to calculate the slew rate of the output voltage during turn-on:

$$\text{Slew Rate (mV/ms)} = 14 * (V_{IN}) * (\text{MULTI_PHASE_RAMP_GAIN}) * (\text{FREQUENCY_SWITCH in MHz})$$

The resulting total rise time can then be calculated:

$$\text{Rise Time} = \text{Output Voltage} / \text{Slew Rate}$$

Enable Pin Operation and Timing

The enable pins (EN0 and EN1) are used to enable and disable each channel of the ZL8802. When operated as a 2-phase converter, use EN0 and ground EN1. The enable pins should be held low whenever a configuration file or script is used to configure the ZL8802, or a PMBus command is sent that could potentially damage the application circuit. When the ZL8802 is used in a self-enabled mode, for example, when EN0 or EN1 is tied to VR5, or to a resistor divider to V_{IN} , the user must consider the ZL8802's default factory settings. When a configuration file is used to configure the ZL8802, the factory default settings are restored to both the user and default stores to set the ZL8802 to an initialized state. Because the default state of the ZL8802 is to be enabled when the enable pin is high, it is possible for the ZL8802 to be enabled while the PMBus commands are sent to the ZL8802 during the configuration process.

The Enable pin is edge triggered to achieve fast turn-off times. As a result, minimum Enable high and Enable low pulse widths must be observed to ensure correct operation. The minimum high and low pulse widths are dependent on the configured rise, fall, and delay times and can be calculated using [Equations 1](#) and [2](#):

$$\text{EN low} > \text{TOFF_DELAY} + \text{TOFF_FALL} + 10.5\text{ms} \quad (\text{EQ. 1})$$

$$\text{EN high} > \text{TON_DELAY} + \text{TON_RISE} + \text{POWER_GOOD_DELAY} + 5.5\text{ms} \quad (\text{EQ. 2})$$

EN low and EN high times shorter than these minimums may result in the device not responding to the trailing edge of the pulse. For example, a EN low pulse below the EN low minimum pulse width may stay in the OFF state until a valid EN low pulse is applied to the EN pin.

When operating the IC in 2 channel mode, avoid transitioning EN0 or EN1 high within 1ms of the beginning of the opposite channel's start-up ramp. For example, if the Page 0 output (VSEN0, PWM) begins to ramp up at the end of the TON_DELAY of 5ms, EN1 should not transition high between 4ms and 6ms.

Power-Good

The ZL8802 provides a Power-Good (PG0, PG1) signal for each channel that indicates the output voltage is within a specified tolerance of its target level and no fault condition exists. By default, the PG pin will assert if the output is within 10% of the target voltage. These limits and the polarity of the pin can be changed using PMBus commands.

A PG delay period is defined as the time from when all conditions within the ZL8802 for asserting PG are met to when the PG pin is actually asserted. This feature is commonly used instead of using an external reset controller to control external digital logic. By default, the ZL8802 PG delay is set equal to 1ms. The PG delay can be set using a PMBus command as described in ["POWER_GOOD_DELAY \(D4h\)" on page 66](#).

Power Management Functional Description

Output Overvoltage Protection

The ZL8802 offers an internal output overvoltage protection circuit that can be used to protect sensitive load circuitry from being subjected to a voltage higher than its prescribed limits. A hardware comparator is used to compare the actual output voltage (seen at the VSEN pin) to a programmable threshold set to 10% higher than the target output voltage (the default setting). If the VSEN voltage exceeds this threshold, the PG pin will deassert and the device can then respond in the following ways:

- Shut down and stay off until the fault has cleared and the device has been disabled and reenabled.
- Shut down, and when the fault is no longer present, attempt to restart.

Refer to ["VOUT_OV_FAULT_RESPONSE \(41h\)" on page 37](#) for details on how to select specific overvoltage fault response options using the VOUT_OV_FAULT_RESPONSE command.

Output Prebias Protection

The ZL8802 provides prebiased start-up operation in 2-channel and single device 2-phase operation. Prebias protection is not provided when operating in current sharing 4-, 6- or 8-phase configurations. An output prebias condition exists when an externally applied voltage is present on a power supply's output before the power supply's control IC is enabled. Certain applications require that the converter not be allowed to sink current during start up if a prebias condition exists at the output. The ZL8802 provides prebias protection by sampling the output voltage before initiating an output ramp.

If a prebias voltage lower than the desired output voltage is present after the Ton-delay time the ZL8802 starts switching with a duty cycle that matches the prebias voltage. This ensures that the ramp-up from the prebias voltage is monotonic. The output voltage is then ramped to the desired output voltage at the ramp rate set by the TON_RISE command.

The resulting output voltage rise time will vary depending on the prebias voltage, but the total time elapsed from the end of the Ton-delay time to when the Ton-rise time is complete and the output is at the desired value will match the preconfigured ramp time (see [Figure 6](#)).

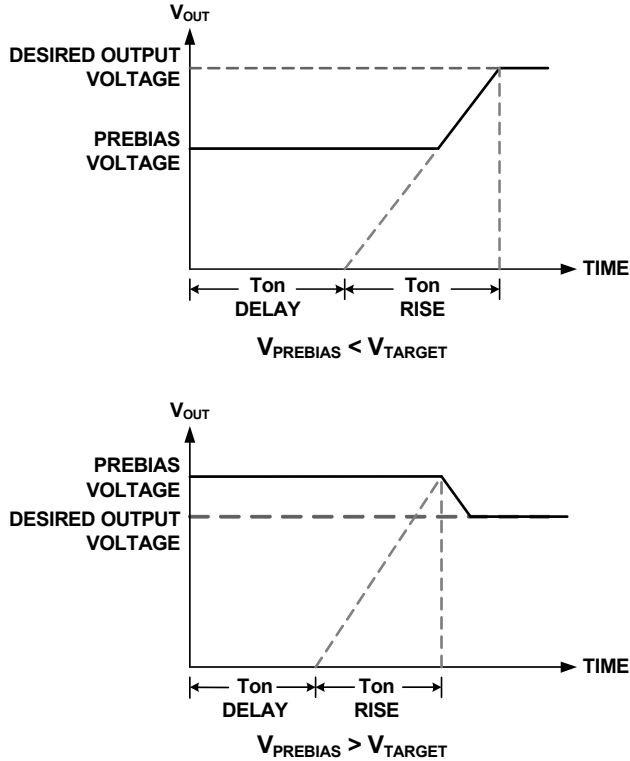

FIGURE 6. OUTPUT RESPONSES TO PREBIAS VOLTAGES

If a prebias voltage higher than the target voltage exists after the preconfigured Ton-delay time and Ton-rise time have completed, the ZL8802 starts switching with a duty cycle that matches the prebias voltage. This ensures that the ramp-down from the prebias voltage is monotonic. The output voltage is then ramped down to the desired output voltage

If a prebias voltage higher than the overvoltage limit exists, the device will not initiate a turn-on sequence and will stay off.

Output Overcurrent Protection

The ZL8802 can protect the power supply from damage from an overloaded or shorted output. When the current limit threshold has been selected (see [“Current Limit Configuration” on page 18](#)), the user can determine the desired response to the fault condition. The following overcurrent protection response options are available:

- Shut down and stay off until the device has been disabled and reenabled.
- Shut down and restart continuously after a delay.

Refer to the [“PMBus Command Detail” on page 27](#) for details on how to select specific overvoltage fault response options using the IOOUT_OC_FAULT_RESPONSE command.

SPS CURRENT SENSING

By default, the ZL8802 senses current by utilizing the IMON output from the ISL9922X Smart Power Stage (SPS). A 6:1 resistor divider is needed between the SPS IMON output and the ISENA and ISENB inputs of the ZL8802, as shown in [Figure 7](#).

Using an ISL9922x device will provide the best current sense accuracy with no action needed from the user.

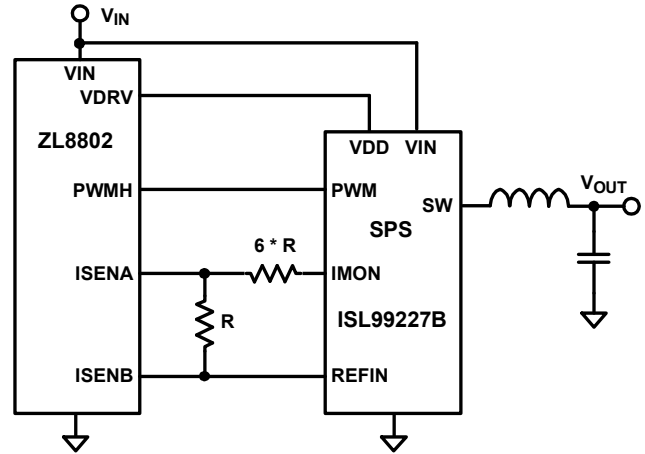

FIGURE 7. SPS CURRENT SENSING

DRMOS CURRENT SENSING

If a DrMOS device must be used, the ZL8802 can also use the inductor DCR current sensing technique. Current sensing is achieved with an R/C network as shown in [Figure 8](#).

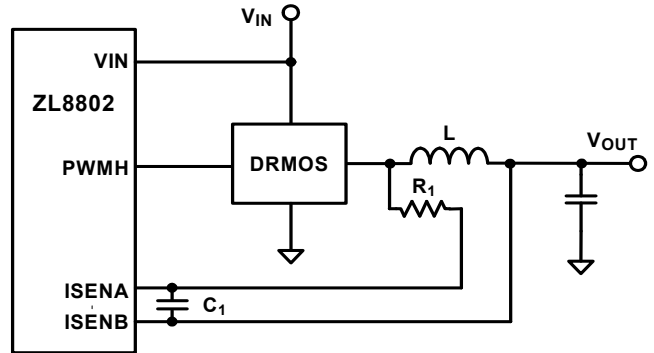

FIGURE 8. DCR CURRENT SENSING

For the voltage across C_1 to reflect the voltage across the DCR of the inductor, the time constant of the inductor must match the time constant of the RC network.

$$\tau_{RC} = \tau_{L/DCR} \quad (EQ. 3)$$

$$R1 \cdot C1 = \frac{L}{DCR}$$

This capacitor, shown as C_1 in [Figure 8](#), should be an X7R or better dielectric, and C_1 should be placed as close to the ZL8802 as possible for the best noise performance. The L and DCR values should be set using the INDUCTOR and IOOUT(0/1)_CAL_GAIN

commands. For L , use the average of the nominal value and the minimum value. Include the effects of tolerance, DC bias, and switching frequency on the inductance when determining the minimum value of L . Use the typical room temperature value for DCR .

Current Limit Configuration

The ZL8802 gives the power supply designer several choices for the fault response during overcurrent or undercurrent conditions. The user can select the number of violations allowed before declaring fault, a blanking time, and the action taken when a fault is detected. These parameters can be configured using the `ISENSE_CONFIG` command.

The blanking time represents the time when no current measurement is taken. This is to avoid taking a reading just after a current load step (less accurate due to potential ringing). It is a configurable parameter from 0 to 832ns.

ZL8802 provides an adjustable maximum full scale sensing range. Three ranges are available: $\pm 25\text{mV}$, $\pm 35\text{mV}$, and $\pm 50\text{mV}$ maximum input voltage.

By default, current sensing is enabled during the inductor current down-slope period of the switching period (D'). In applications where the steady state duty cycle is >0.5 , for example, a 5V to 3.3V converter, the ZL8802 can be configured to sense current during the inductor up-slope period of the switching cycle (D).

The user has the option of selecting how many consecutive overcurrent readings must occur before an overcurrent fault and subsequent shutdown are initiated. Either 1, 3, 5, 7, 9, 11, or 13 consecutive faults can be selected.

The current limit thresholds are set with four commands:

1. `IOUT_OC_FAULT_LIMIT` – This sets the overcurrent threshold that must be exceeded by the number of consecutive times chosen in `ISENSE_CONFIG`.
2. `IOUT_UC_FAULT_LIMIT` – This is the same as `IOUT_OC_FAULT_LIMIT`, but represents the negative current that flows lower FET during the D' interval. Large negative currents can flow during faults such as a higher voltage rail being shorted to a lower voltage rail.
3. `IOUT_AVG_OC_FAULT_LIMIT` – This limit is similar to `IOUT_OC_FAULT_LIMIT`, but the limit represents an average reading over several switching cycles. Because it is an average, the response time is slower, but the limit can be set closer to the maximum average expected output current.
4. `IOUT_AVG_UC_FAULT_LIMIT` – This limit is similar to `IOUT_AVG_OC_FAULT_LIMIT`, but represents the negative current that flows lower FET during the D' interval.

Input Current Monitor

The input current can be monitored through the `IINN` and `IINP` pins. The input current monitor input should be connected across a current sensing resistor in series with the input supply. The `IINP` pin is connected to the input supply side of the current sense resistor and the `IINN` pin is connected to the ZL8802 VDD side of the current sense resistor. Using the `IIN_SCALE` command, set the current sense resistor value. Select the current sense resistor value such that the maximum expected input current times the

current sense resistor value does not exceed the maximum current sensing input voltage of 20mV.

If this feature is not used, `IINN` and `IINP` should be tied to VDD.

Thermal Overload Protection

The ZL8802 includes an on-chip thermal sensor that continuously measures the internal temperature of the die. This thermal sensor is used to provide both over-temperature and under-temperature protection. If the over-temperature limit is exceeded, or the temperature falls below the under-temperature limit, the ZL8802 is shut down. The over-temperature and under-temperature limits are set by the `OT_FAULT_LIMIT` and `UT_FAULT_LIMIT` respectively. The ZL8802 will not attempt to restart until the temperature has fallen below the `OT_WARN_LIMIT` for over-temperature faults or has risen above the `UT_WARN_LIMIT` for under-temperature faults. The default temperature limits are $+125^\circ\text{C}$ and -45°C , but the user can set the limits to different values if desired. Note that setting a higher over-temperature or under-temperature limit may result in permanent damage to the device. When the device has been disabled due to an internal temperature fault, the user can select one of several fault response options as follows:

- Shut down and stay off until the fault has cleared and the device has been disabled and reenabled.
- Shut down and restart continuously after a delay.

Refer to [“PMBus Command Detail” on page 27](#) for details on how to select specific overvoltage fault response options using the `OT_FAULT_RESPONSE` and `UT_FAULT_RESPONSE` commands.

Voltage Tracking

Numerous high performance systems place stringent demands on the order in which the power supply voltages are turned on. This is particularly true when powering FPGAs, ASICs, and other advanced processor devices that require multiple supply voltages to power a single die. In most cases, the I/O interface operates at a higher voltage than the core and therefore the core supply voltage must not exceed the I/O supply voltage according to manufacturer specifications.

The ZL8802 integrates a tracking scheme that allows one of its outputs (Channel 0 or Channel 1), or the single output in a dual phase application, to track a voltage that is applied to the `VTRK` pin with no external components required. The `VTRK` pin is an analog input that, when tracking mode is enabled, configures the voltage applied to the `VTRK` pin to act as a reference for the device's output regulation.

Coincident. This mode configures the ZL8802 to ramp its output voltage at the same rate as the voltage applied to the `VTRK` pin until it reaches its desired output voltage. The device that is tracking another output voltage (slave) must be set to its desired steady state output voltage, that is, the `VOUT_COMMAND` is set to the final output voltage.

Ratiometric. This mode configures the ZL8802 to ramp its output voltage at a rate that is a percentage of the voltage applied to the `VTRK` pin. The default setting is 50%, but an external resistor string can be used to configure a different tracking ratio. The device that is tracking another output voltage (slave) must be set to its desired steady-state output voltage, that is, the `VOUT_COMMAND` is set to the final output voltage.

The master ZL8802 device in a tracking group is defined as the device that has the highest target output voltage within the group. This master device will control the ramp rate of all tracking devices and is not configured for tracking mode. The maximum tracking rise time is 1V/ms. The slave device must be enabled before the master.

Any device that is configured for tracking mode will ignore its Ton-delay and Ton-rise settings and its output will take on the turn-on/turn-off characteristics of the reference voltage present at the VTRK pin.

Tracking mode can be configured by using the TRACK_CONFIG command.

Note that current sharing groups that are also configured to track another voltage do not offer prebias protection; a minimum load should therefore be enforced to avoid the output voltage from being held up by an outside force.

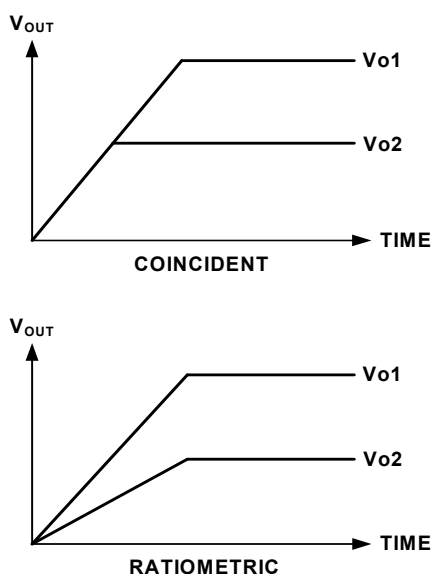

FIGURE 9. TRACKING MODES

External Voltage Monitoring

The voltage monitoring (TMON) pin is available to monitor the voltage supply for the external driver IC. The TMON input must be scaled by a 16:1 ratio to read-back the TMON voltage correctly. A 100kΩ and 6.65kΩ resistor divider is recommended. Overvoltage and undervoltage fault thresholds can be set using MFR_TMON_OV_FAULT_LIMIT and MFR_TMON_UV_FAULT_LIMIT commands. The response to these limits are set using the TMON_OV_FAULT_RESPONSE and TMON_UV_FAULT_RESPONSE commands. To ignore the TMON input, set the TMON_OV and _UV_FAULT_RESPONSE to 00h.

When the device has been disabled due to TMON fault, the user can select one of several fault response options as follows:

- Shut down and stay off until the fault has cleared and the device has been disabled and reenabled.
- Shut down and restart continuously after a delay.

SMBus Communications

The ZL8802 provides a SMBus digital interface. The ZL8802 can be used with any standard 2-wire SMBus host device. In addition, the device is compatible with SMBus version 2.0 and includes an SALRT line to help mitigate bandwidth limitations related to continuous fault monitoring. Pull-up resistors are required on the SMBus. The pull-up resistor can be tied to VR5 or to an external 3.3V or 5V supply as long as this voltage is present before or during device power-up. The ideal design will use a central pull-up resistor that is well-matched to the total load capacitance. The minimum pull-up resistance should be limited to a value that enables any device to assert the bus to a voltage that will ensure a logic 0 (typically 0.8V at the device monitoring point) given the pull-up voltage (5V if tied to VR5) and the pull-down current capability of the ZL8802 (nominally 4mA). A pull-up resistor of 10kΩ is a good value for most applications.

SMBus data and clock lines should be routed with a closely coupled return or ground plane to minimize coupled interference (noise). Excessive noise on the data and clock lines that cause the voltage on these lines to cross the high and low logic thresholds of 2.0V and 0.8V respectively will cause command transmissions to be interrupted and result in slow bus operation or missed commands. A 10kΩ resistor on each line provides good performance on an SMBus with fewer than 10 devices.

The ZL8802 accepts most standard PMBus commands. When enabling the device with ON_OFF_CONFIG command, it is recommended that the enable pin is tied to SGND.

In addition to bus noise considerations, it is important to ensure that user connections to the SMBus are compliant to the PMBus command standards. Any device that can malfunction in a way that permanently shorts SMBus lines will disable PMBus communications. Incomplete PMBus commands can also cause the ZL8802 to halt PMBus communications. This can be corrected by disabling, then reenabling the device.

Digital-DC Bus

The Digital-DC Communications (DDC) bus is used to communicate between Intersil Digital-DC devices, and within the ZL8802 itself. This dedicated bus provides the communication channel between devices for features such as sequencing, fault spreading and current sharing. **The DDC pin must be pulled-up to an external 2.5V to 5.0V supply, (or configured as a push-pull output using the USER_GLOBAL_CONFIG command) even if the ZL8802 is operating stand-alone.** In addition, the DDC pin must be pulled up or configured as a push-pull output before the Enable pin is set high. Push-pull mode can only be used when the ZL8802 is operating stand-alone. The DDC pin on all Digital-DC devices that utilize sequencing, fault spreading or current sharing must be connected together. The DDC pin on all Digital-DC devices in an application should be connected together. A pull-up resistor is required on the DDC bus to guarantee the rise time as follows:

$$\text{Riset time} = R_{PU} \cdot C_{LOAD} \leq 1\mu\text{s} \quad (\text{EQ. 4})$$

Where R_{PU} is the DDC bus pull-up resistance and C_{LOAD} is the bus loading. The pull-up resistor can be tied to VR5 or to an external 3.3V or 5V supply as long as this voltage is present before or during device power-up. Generally, each device

connected to the DDC bus presents approximately 12pF of capacitive loading. The ideal design will use a central pull-up resistor that is well-matched to the total load capacitance. In power module applications, the user should consider whether to place the pull-up resistor on the module or on the PCB of the end application. The minimum pull-up resistance should be limited to a value that enables any device to assert the bus to a voltage that will ensure a logic 0 (typically 0.8V at the device monitoring point) given the pull-up voltage (5V if tied to VR5) and the pull-down current capability of the ZL8802 (nominally 4mA). As with SMBus data and clock lines, the DDC data line should be routed with a closely coupled return or ground plane to minimize coupled interference (noise). Excessive noise on the DDC signal can cause the voltage on this line to cross the high and low logic thresholds of 2.0V and 0.8V respectively and will cause command transmissions to be interrupted and result in slow bus operation or missed commands. For less than 10 devices on the DDC bus a 10kΩ resistor provides good performance.

Phase Spreading

When multiple point-of-load converters share a common DC input supply, it is desirable to adjust the clock phase offset of each device such that not all devices have coincident rising edges. Setting each converter to start its switching cycle at a different point in time can dramatically reduce input capacitance requirements. Because the peak current drawn from the input supply is effectively spread out over a period of time, the peak current drawn at any given moment is reduced and the power losses proportional to I_{RMS}^2 are reduced.

To enable phase spreading, all converters must be synchronized to the same switching clock. Configuring the SYNC pin is described in [“Configurable Pins” on page 12](#). Selecting the phase offset for the device is accomplished by selecting a device address according to [Equation 5](#):

$$\text{Phase offset} = \text{device address} \times 45^\circ \quad (\text{EQ. 5})$$

The phase offset of each device can also be set to any value between 0° and 360° in 22.5° increments using the INTERLEAVE PMBus command.

Output Sequencing

A group of Intersil digital power devices can be configured to power up in a predetermined sequence. This feature is especially useful when powering advanced processors, FPGAs, and ASICs that require one supply to reach its operating voltage before another supply reaching its operating voltage to avoid latch-up from occurring. Multidevice sequencing can be achieved by configuring each device using the SEQUENCE PMBus command.

Multiple device sequencing is achieved by issuing PMBus commands to assign the preceding device in the sequencing chain as well as the device that will follow in the sequencing chain.

The enable (EN) pins of all devices in a sequencing group must be tied together and driven high to initiate a sequenced turn-on of the group. Enable must be driven low to initiate a sequenced turn-off of the group. To achieve sequenced turn-off of a group of sequenced devices, all the devices should be configured to turn

off using the “soft-off”, or ramped down behavior, in the ON_OFF_CONFIG PMBus command.

When sequencing on, the first device to ramp up, called the “prequel”, sends a message through the DDC bus to the next device, called the “sequel” when the prequel’s Power-Good (PG) signal is driven high.

When sequencing off, the sequel will send a message to the prequel to begin the prequel’s ramp down after the sequel has completed its own ramp down.

Sequencing can also be accomplished by connecting the enable pin of a sequel device to the Power-Good pin of a prequel device. Sequencing is also achieved by using the TON_DELAY and TON_RISE commands and choosing appropriate delay and rise durations such that sequel devices start after their associated prequel devices. The drawback to this method is that if a prequel device fails to start properly, its sequel device will still start and ramp on according to its delay and rise time settings.

Fault Spreading

Digital-DC devices can be configured to broadcast a fault event over the DDC bus to the other devices in the group. When a fault occurs and the device is configured to shut down on a fault, the device will shut down and broadcast the fault event over the DDC bus. The other devices on the DDC bus will shut down together if configured to do so, and will attempt to restart in their prescribed order if configured to do so.

Active Current Sharing

The PWM outputs of the ZL8802 are used in parallel to create a dual phase power rail. The device outputs will share the current equally within a few percent, assuming all external sensing element variations and tolerances are negligible. Current sensing element tolerances must be taken into account, or adjusted for using the IOUT_CAL_GAIN and IOUT_CAL_OFFSET commands in any application.

The ZL8802 will current share between phases without utilizing output voltage droop.

Droop resistance is used in 4-phase current sharing to add artificial resistance in the output voltage path to control the slope of the load line curve, calibrating out the physical parasitic mismatches due to power train components and PCB layout.

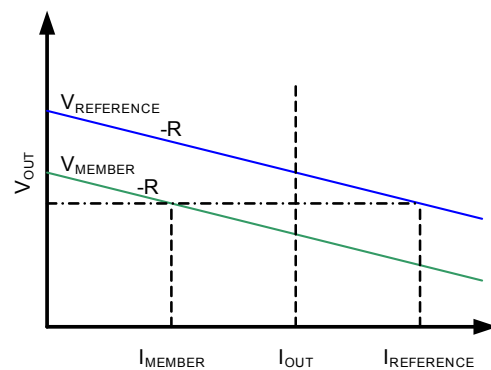

FIGURE 10. ACTIVE CURRENT SHARING

When current sharing up to 2 ZL8802s (4 phases total), the ZL8802 uses a low-bandwidth, first-order digital current sharing technique to balance the unequal device output loading by aligning the load lines of member devices to a reference device.

Upon system start-up, the lowest numbered phase is defined as the reference phase and all other phases are member phases. The reference phase broadcasts its current over the DDC bus. The member phases use the reference current information to trim their reference voltages (V_{MEMBER}) to balance the current loading of each device in the system.

Figure 10 on page 20 shows that, for load lines with identical slopes, the member reference voltage is increased towards the reference voltage which closes the gap between the inductor currents.

The relation between reference and member current and voltage is given by the following Equation 6:

$$V_{MEMBER} = V_{OUT} + R \times (I_{REFERENCE} - I_{MEMBER}) \quad (EQ. 6)$$

Where R is the value of the droop resistance. The VOUT_DROOP command is used to set the device output voltage droop to achieve 4-, 6- or 8-phase current sharing.

4-, 6-, and 8-phase current sharing groups must have their DDC and SYNC pins tied together to achieve current sensing and ensure accurate phase offsets between current sharing phases.

Temperature Monitoring Using XTEMP Pin

Each channel of the ZL8802 supports measurement of an external device temperature using either a thermal diode integrated in a processor, FPGA or ASIC, or using a discrete diode-connected 2N3904 NPN transistor. Figure 11 illustrates the typical connections required. A noise filtering capacitor, not exceeding 100pF, should be connected across the external temperature sensing device. The external temperature sensors can be used to provide the temperature reading for over-temperature and under-temperature faults. The external sensors can also be used to provide more accurate temperature compensation for inductor DCR current sensing by being placed close to the inductor. These options for the external temperature sensors are selected using the USER_CONFIG PMBus command.

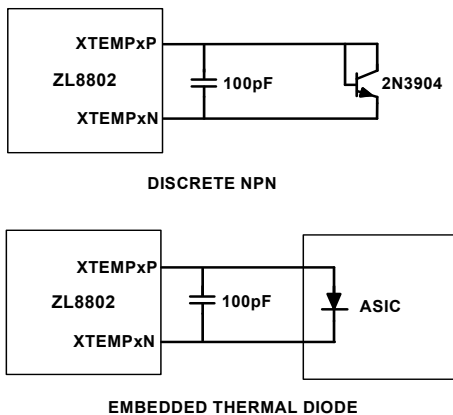

FIGURE 11. EXTERNAL TEMPERATURE MONITORING

Nonvolatile Memory and Security Features

The ZL8802 has internal nonvolatile memory where user configurations are stored. Integrated security measures ensure that the user can only restore the device to a level that has been made available to them. During the initialization process, the ZL8802 checks for stored values contained in its internal nonvolatile memory. The ZL8802 offers two internal memory storage units that are accessible by the user as follows:

User Store: The user store is the most commonly used store. It provides the ability to modify certain power supply settings while still protecting the equipment from modifying values that can lead to a system level fault. The equipment manufacturer would use the user store to achieve this goal.

Default Store: The default store is less commonly used. It provides a means to protect the circuit from damage by preventing the user from modifying certain values that are related to the physical construction of the circuit. In this case, the Original Equipment Manufacturer (OEM) would use the default store in a protected mode and allow the user to restore the device to its default settings. In this case the user store would be available to the end-user for making changes, but would restrict the user from restoring the device to the factory settings or modifying the default store.

The user store takes priority over the Default Store. If there are no values set in the user or default store, then the device will use the pin-strap setting value.

For details regarding protection of the user and default stores, see the PASSWORD PMBus command.

Monitoring Through SMBus

A system controller can monitor a wide variety of different ZL8802 parameters through the SMBus interface. The device can monitor for fault conditions by monitoring the SALRT pin, which will be asserted when any number of preconfigured fault conditions occur.

The device can also be monitored continuously for any number of power conversion parameters including, but not limited to, the following:

- Input voltage
- Output voltage
- Input current
- Output current
- Internal junction temperature
- Temperature of an external device
- Switching frequency
- Duty cycle
- Fault status information

The PMBus Host should respond to SALRT as follows:

1. ZL device pulls SALRT low.
2. PMBus host detects that SALRT is now low, and performs transmission with Alert Response Address to find which ZL device is pulling SALRT low.

3. PMBus host talks to the ZL device that has pulled SALRT low. The actions that the host performs are up to the system designer.

Refer to “[PMBus Command Detail](#)” on page 27 for details on how to monitor specific parameters through the SMBus interface.

If multiple devices are faulting, SALRT will still be low after doing the above steps and will require transmission with the Alert Response Address repeatedly until all faults are cleared.

PMBus Command Summary

CODE	COMMAND NAME	DESCRIPTION	TYPE	DATA FORMAT	DEFAULT VALUE	DEFAULT SETTING
00h	PAGE	Selects Controller 0, 1, or both	R/W	BIT	00h	Page 0 Controller addressed
01h	OPERATION	Enable/disable, margin settings	R/W	BIT	00h	Immediate off, nominal margin
02h	ON_OFF_CONFIG	On/off configuration settings	R/W	BIT	17h	ENABLE pin control, active high
03h	CLEAR_FAULTS	Clears faults	Write	N/A	N/A	N/A
11h	STORE_DEFAULT_ALL	Stores values to default store	Write	N/A	N/A	N/A
12h	RESTORE_DEFAULT_ALL	Restores values from default store	Write	N/A	N/A	N/A
15h	STORE_USER_ALL	Stores values to user store	Write	N/A	N/A	N/A
16h	RESTORE_USER_ALL	Restores values from user store	Write	N/A	N/A	N/A
20h	VOUT_MODE	Reports V _{OUT} mode and exponent	Read	BIT	13h	Linear mode, exponent = -13
21h	VOUT_COMMAND	Sets nominal V _{OUT} set-point	R/W	L16u	N/A	Pin-strap setting
22h	VOUT_TRIM	Applies offset voltage to V _{OUT} set-point	R/W	L16s	0000h	0V
23h	VOUT_CAL_OFFSET	Applies offset voltage to V _{OUT} set-point	R/W	L16s	0000h	0V
24h	VOUT_MAX	Sets maximum V _{OUT} set-point	R/W	L16u	N/A	1.15 x VSET pin-strap setting
25h	VOUT_MARGIN_HIGH	Sets V _{OUT} set-point during margin high	R/W	L16u	N/A	1.05 x VSET pin-strap setting
26h	VOUT_MARGIN_LOW	Sets V _{OUT} set-point during margin low	R/W	L16u	N/A	0.95 x VSET pin-strap setting
27h	VOUT_TRANSITION_RATE	Sets V _{OUT} transition rate during margin commands	R/W	L11	BA00h	1V/ms
28h	VOUT_DROOP	Sets V/I slope for total rail output current (all phases combined)	R/W	L11	N/A	CFG pin-strap setting
33h	FREQUENCY_SWITCH	Sets switching frequency	R/W	L11	N/A	SYNC pin-strap setting
37h	INTERLEAVE	Configures phase offset during group operation	R/W	BIT	N/A	CFG pin-strap setting
38h	IOUT_CAL_GAIN	Sets impedance of current sense circuit	R/W	L11	B2AEh	0.67mΩ
39h	IOUT_CAL_OFFSET	Sets an offset to I _{OUT} sense circuit	R/W	L11	BD00h	-1.5A
40h	VOUT_OV_FAULT_LIMIT	Sets the V _{OUT} overvoltage fault threshold	R/W	L16u	N/A	1.10 x VSET pin-strap setting
41h	VOUT_OV_FAULT_RESPONSE	Sets the V _{OUT} overvoltage fault response	R/W	BIT	80h	Disable, no retry
44h	VOUT_UV_FAULT_LIMIT	Sets the V _{OUT} undervoltage fault threshold	R/W	L16u	N/A	0.85 x VSET pin-strap setting
45h	VOUT_UV_FAULT_RESPONSE	Sets the V _{OUT} undervoltage fault response	R/W	BIT	80h	Disable, no retry
46h	IOUT_OC_FAULT_LIMIT	Sets the I _{OUT} peak overcurrent fault threshold for each phase	R/W	L11	N/A	CFG pin-strap setting
4Bh	IOUT_UC_FAULT_LIMIT	Sets the I _{OUT} valley undercurrent fault threshold for each phase	R/W	L11	N/A	-1 * IOUT_OC_FAULT_LIMIT from CFG pin-strap setting
4Fh	OT_FAULT_LIMIT	Sets the over-temperature fault limit	R/W	L11	EBE8h	+125 °C
50h	OT_FAULT_RESPONSE	Sets the over-temperature fault response	R/W	BIT	BFh	Continuous retry, 280ms retry delay
51h	OT_WARN_LIMIT	Sets the over-temperature warning limit	R/W	L11	EB70h	+110 °C
52h	UT_WARN_LIMIT	Sets the under-temperature warning limit	R/W	L11	DC40h	-30 °C

PMBus Command Summary (Continued)

CODE	COMMAND NAME	DESCRIPTION	TYPE	DATA FORMAT	DEFAULT VALUE	DEFAULT SETTING
53h	UT_FAULT_LIMIT	Sets the under-temperature fault limit	R/W	L11	E530h	-45°C
54h	UT_FAULT_RESPONSE	Sets the under-temperature fault response	R/W	BIT	BFh	Continuous retry, 280ms retry delay
55h	VIN_OV_FAULT_LIMIT	Sets the V_{IN} overvoltage fault threshold	R/W	L11	D380h	14V
56h	VIN_OV_FAULT_RESPONSE	Sets the V_{IN} overvoltage fault response	R/W	BIT	80h	Disable, no retry
57h	VIN_OV_WARN_LIMIT	Sets the V_{IN} overvoltage warning threshold	R/W	L11	D360h	13.5V
58h	VIN_UV_WARN_LIMIT	Sets the V_{IN} undervoltage warning threshold	R/W	L11	N/A	1.1 x UVLO pin-strap setting
59h	VIN_UV_FAULT_LIMIT	Sets the V_{IN} undervoltage fault threshold	R/W	L11	N/A	UVLO pin-strap setting
5Ah	VIN_UV_FAULT_RESPONSE	Sets the V_{IN} undervoltage fault response	R/W	BIT	BFh	Continuous retries, 280ms retry delay
5Eh	POWER_GOOD_ON	Sets the voltage threshold for Power-Good indication	R/W	L16u	N/A	0.9 x VSET pin-strap setting
60h	TON_DELAY	Sets the delay time from enable to V_{OUT} rise	R/W	L11	CA80h	5ms
61h	TON_RISE	Sets the rise time of V_{OUT} after ENABLE and TON_DELAY	R/W	L11	CA80h	5ms
64h	TOFF_DELAY	Sets the delay time from DISABLE to start of V_{OUT} fall	R/W	L11	CA80h	5ms
65h	TOFF_FALL	Sets the fall time for V_{OUT} after DISABLE and TOFF_DELAY	R/W	L11	CA80h	5ms
78h	STATUS_BYTE	First byte of STATUS_WORD	Read	BIT	00h	No faults
79h	STATUS_WORD	Summary of critical faults	Read	BIT	0000h	No faults
7Ah	STATUS_VOUT	Reports V_{OUT} warnings/faults	Read	BIT	00h	No faults
7Bh	STATUS_IOUT	Reports I_{OUT} warnings/faults	Read	BIT	00h	No faults
7Ch	STATUS_INPUT	Reports input warnings/faults	Read	BIT	00h	No faults
7Dh	STATUS_TEMP	Reports temperature warnings/faults	Read	BIT	00h	No faults
7Eh	STATUS_CML	Reports communication, memory, logic errors	Read	BIT	00h	No faults
80h	STATUS_MFR_SPECIFIC	Reports voltage monitoring/clock synchronization faults	Read	BIT	00h	no faults
88h	READ_VIN	Reports input voltage measurement	Read	L11	N/A	N/A
89h	READ_IIN	Reports input current measurement	Read	L11	N/A	N/A
8Bh	READ_VOUT	Reports output voltage measurement	Read	L16u	N/A	N/A
8Ch	READ_IOUT	Reports output current measurement	Read	L11	N/A	N/A
8Dh	READ_TEMPERATURE_1	Reports internal temperature measurement	Read	L11	N/A	N/A
8Eh	READ_TEMPERATURE_2	Reports external temperature measurement from XTEMP pins	Read	L11	N/A	N/A
8Fh	READ_TEMPERATURE_3	Reports external temperature measurement from VMON/TMON pin.	Read	L11	N/A	N/A
94h	READ_DUTY_CYCLE	Reports actual duty cycle	Read	L11	N/A	N/A
95h	READ_FREQUENCY	Reports actual switching frequency	Read	L11	N/A	N/A
98h	PMBUS_REVISION	Reports the PMBUS revision used	Read	BIT	22h	P1 R1.2, P2 R1.2

PMBus Command Summary (Continued)

CODE	COMMAND NAME	DESCRIPTION	TYPE	DATA FORMAT	DEFAULT VALUE	DEFAULT SETTING
99h	MFR_ID	Sets a user defined identification	R/W	ASC	N/A	<null>
9Ah	MFR_MODEL	Sets a user defined model	R/W	ASC	N/A	<null>
9Bh	MFR_REVISION	Sets a user defined revision	R/W	ASC	N/A	<null>
9Ch	MFR_LOCATION	Sets a user defined location identifier	R/W	ASC	N/A	<null>
9Dh	MFR_DATE	Sets a user defined date	R/W	ASC	N/A	<null>
9Eh	MFR_SERIAL	Sets a user defined serialized identifier	R/W	ASC	N/A	<null>
ADh	IC_DEVICE_ID	Reports device identification information	Read	CUS	49A02D00h	Intersil ZL8802
A Eh	IC_DEVICE_REV	Reports device revision information	Read	CUS	01000000h	Initial Release
B0h	USER_DATA_00	Sets user defined data	R/W	ASC	N/A	<null>
CEh	MIN_VOUT_REG	Sets a minimum start-up voltage	R/W	L11	0000h	0mV
D0h	ISENSE_CONFIG	Configures current sensing circuitry	R/W	BIT	620Eh	Downslope, 5 fault count, 384ns blanking, high range
D1h	USER_CONFIG	Configures several user-level features	R/W	BIT	N/A	Set by CFG pin-strap setting
D2h	IIN_CAL_GAIN	Sets the resistance of the input current sensing resistor	R/W	L11	C200h	2mΩ
D3h	DDC_CONFIG	Configures the DDC addressing and current sharing	R/W	BIT	N/A	Set by pin-strapped PMBus address and CFG pin-strap setting
D4h	POWER_GOOD_DELAY	Sets the delay between PG threshold and PG assertion	R/W	L11	BA00h	1ms
D5h	MULTI_PHASE_RAMP_GAIN	Adjusts the ramp-up and ramp-down rate by setting the feedback gain	R/W	CUS	03h	3
D6h	INDUCTOR	Sets the inductor value	R/W	L11	B133h	0.3μH
D7h	SNAPSHOT_FAULT_MASK	Masks faults that cause a snapshot to be taken	R/W	BIT	0000h	No faults masked
D8h	OVUV_CONFIG	Configures output voltage OV/UV fault detection	R/W	BIT	00h	Low side FET off on fault, 1 violation triggers fault.
D9h	XTEMP_SCALE	Calibrates external temperature sensor	R/W	L11	BA00h	1/degree C
DAh	XTEMP_OFFSET	Offset calibration for external temperature sensor	R/W	L11	0000h	No offset
DBh	MFR_SMBALERT_MASK	Identifies which fault limits will not assert SALRT	R/W	Custom	00..00h	N/A
DCh	TEMPCO_CONFIG	Sets tempco settings	R/W	BIT	00h	Oppm/°C
DDh	PINSTRAP_READ_STATUS	Reads pin-strap settings	Read	BIT	N/A	Set by pin-straps
DFh	ASCR_CONFIG	Configures the ASCR settings	R/W	BIT	N/A	ASCRCFG pin-strap setting
E0h	SEQUENCE	DDC rail sequencing configuration	R/W	BIT	00h	Prequel and sequel disabled
E1h	TRACK_CONFIG	Configures voltage tracking	R/W	BIT	00h	Tracking disabled
E2h	DDC_GROUP	Configures group ID, fault spreading, OPERATION, and V _{OUT}	R/W	BIT	N/A	Set by CFG pin-strap
E4h	DEVICE_ID	Returns the device identifier string	Read	ASC	TBD	ZL8802, current revisions
E5h	MFR_IOUT_OC_FAULT_RESPONSE	Configures the I _{OUT} overcurrent fault response	R/W	BIT	80h	Disable, no retry
E6h	MFR_IOUT_UC_FAULT_RESPONSE	Configures the I _{OUT} undercurrent fault response	R/W	BIT	80h	Disable, no retry

PMBus Command Summary (Continued)

CODE	COMMAND NAME	DESCRIPTION	TYPE	DATA FORMAT	DEFAULT VALUE	DEFAULT SETTING
E7h	IOUT_AVG_OC_FAULT_LIMIT	Sets the I _{OUT} average overcurrent fault threshold	R/W	L11	N/A	Set by CFG pin-strap
E8h	IOUT_AVG_UC_FAULT_LIMIT	Sets the I _{OUT} average undercurrent fault threshold	R/W	L11	N/A	-1* IOUT_AVG_OC_FAULT_LIMIT from CFG pin-strap setting
E9h	USER_GLOBAL_CONFIG	Sets options pertaining to advanced features	R/W	BIT	N/A	Set by CFG pin-strap setting
EAh	SNAPSHOT	32-byte read-back of parametric and status values	Read	BIT	N/A	<null>
F0h	LEGACY_FAULT_GROUP	Configures fault group compatibility with older Intersil digital power devices	R/W	BIT	00000000h	<null>
F3h	SNAPSHOT_CONTROL	Snapshot feature control command	R/W	BIT	00h	N/A
F4h	RESTORE_FACTORY	Restores device to the hard-coded default values	Write	N/A	N/A	N/A
F5h	MFR_VMON_OV_FAULT_LIMIT	Sets the V _{MON} overvoltage fault threshold	R/W	L11	C266h	2.4V, SPS OT trip voltage
F6h	MFR_VMON_UV_FAULT_LIMIT	Sets the V _{MON} undervoltage fault threshold	R/W	L11	B0CCh	0.2V, corresponds to -50 °C
F7h	MFR_READ_VMON	Reads the V _{MON} voltage	Read	L11	N/A	N/A
F8h	VMON_OV_FAULT_RESPONSE	Configures the V _{MON} overvoltage fault response	R/W	BIT	BFh	Continuous retry
F9h	VMON_UV_FAULT_RESPONSE	Configures the V _{MON} undervoltage fault response	R/W	BIT	BFh	Continuous retry
FAh	SECURITY_LEVEL	Reports the security level	Read	Hex	01h	Public security level
FBh	PRIVATE_PASSWORD	Sets the private password string	R/W	ASC	00...00h	<null>
FCh	PUBLIC_PASSWORD	Sets the public password string	R/W	ASC	00...00h	<null>
FDh	UNPROTECT	Identifies which commands are protected	R/W	Custom	FF...FFh	No commands are protected

PMBus Use Guidelines

The PMBus is a powerful tool that allows the user to optimize circuit performance by configuring the ZL8802 for their application. When configuring the ZL8802 in a circuit, the ZL8802 should be disabled whenever most settings are changed with PMBus commands. Some exceptions to this recommendation are OPERATION, ON_OFF_CONFIG, CLEAR_FAULTS, VOUT_COMMAND, VOUT_MARGIN_HIGH, VOUT_MARGIN_LOW, and ASCCR_CONFIG. While the device is enabled any command can be read. Many commands do not take effect until after the device has been reenabled, hence the recommendation that commands that change device settings are written while the device is disabled.

When sending the STORE_DEFAULT_ALL, STORE_USER_ALL, RESTORE_DEFAULT_ALL, and RESTORE_USER_ALL commands, it is recommended that no other commands are sent to the device for 100ms after sending STORE or RESTORE commands.

In addition, there should be a 2ms delay between repeated READ commands sent to the same device. When sending any other command, a 5ms delay is recommended between repeated commands sent to the same device.

SUMMARY:

All commands can be read at any time.

Always disable the ZL8802 when writing commands that change device settings. Exceptions to this rule are commands intended to be written while the device is enabled, for example, VOUT_MARGIN_HIGH.

To be sure a change to a device setting has taken effect, write the STORE_USER_ALL command, then cycle input power and reenable the device.

PMBus Data Formats

Linear-11 (L11)

The L11 data format uses 5-bit two's complement exponent (N) and 11-bit two's complement mantissa (Y) to represent real world decimal value (X).

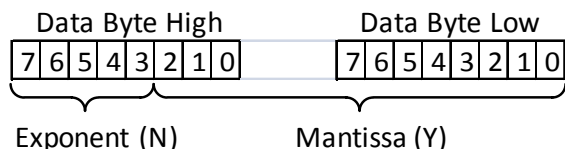

Relation between real world decimal value (X), N, and Y is: $X = Y \cdot 2^N$

Linear-16 Unsigned (L16u)

The L16u data format uses a fixed exponent (hard-coded to $N = -13h$) and a 16-bit unsigned integer mantissa (Y) to represent real world decimal value (X). Relation between real world decimal value (X), N, and Y is: $X = Y \cdot 2^{-13}$

Linear-16 Signed (L16s)

The L16s data format uses a fixed exponent (hard-coded to $N = -13h$) and a 16-bit two's complement mantissa (Y) to represent real world decimal value (X).

The relation between real world decimal value (X), N, and Y is: $X = Y \cdot 2^{-13}$

Bit Field (BIT)

An explanation of Bit Field is provided in [“PMBus Command Detail”](#) starting on [page 27](#).

Custom (CUS)

An explanation of the Custom data format is provided in [“PMBus Command Detail”](#). A combination of Bit Field and integer are a common type of Custom data format.

ASCII (ASC)

A variable length string of text characters in the ASCII data format.

PMBus Command Detail

PAGE (00h)

Definition: Selects Controller 0, Controller 1, or both Controllers 0 and 1 to receive commands. All commands following this command will be received and acted on by the selected controller or controllers.

Data Length in Bytes: 1

Data Format: Bit Field

Type: R/W

Protectable: No

Default Value: 00h (Page 0)

Units: N/A

COMMAND	PAGE (00h)							
Format	Bit Field							
Bit Position	7	6	5	4	3	2	1	0
Access	R/W	R/W	R/W	R/W	R/W	R/W	R/W	R/W
Function	See Following Table							
Default Value	0	0	0	0	0	0	0	0

BITS 7:4	BITS 3:0	PAGE
0000	0000	0
0000	0001	1
1111	1111	Both

OPERATION (01h)

Definition: Sets Enable, Disable, and V_{OUT} Margin settings. This command can also be monitored to read the operating state of the device on bits 7:6. Writing immediate off will turn off the output and ignore TOFF_DELAY and TOFF_FALL settings. This command is not stored like other PMBus commands. The value read reflects the current state of the device. When this command is written the command takes effect, but if a STORE_USER_ALL written and the device is reenabled, the OPERATION settings may not be the same settings that were written before the device was reenabled.

Paged or Global: Paged

Data Length in Bytes: 1

Data Format: Bit Field

Type: R/W

Protectable: Yes

Default Value: 00h (immediate off)

Units: N/A

COMMAND	OPERATION (01h)							
Format	Bit Field							
Bit Position	7	6	5	4	3	2	1	0
Access	R/W	R/W	R/W	R/W	R/W	R/W	R/W	R/W
Function	See Following Table							
Default Value	0	0	0	0	0	0	0	0

BITS 7:6	BITS 5:4	BITS 3:0 (NOT USED)	UNIT ON OR OFF	MARGIN STATE
00	00	0000	Immediate off (No sequencing)	N/A
01	00	0000	Soft off (With sequencing)	N/A
10	00	0000	On	Nominal
10	01	0000	On	Margin Low
10	10	0000	On	Margin High

NOTE: Bit combinations not listed above may cause command errors.

ON_OFF_CONFIG (02h)

Definition: Configures the interpretation and coordination of the OPERATION command and the ENABLE pin (EN). When bit 0 is set to 1 (turn off the output immediately), the TOFF_FALL setting is ignored.

Paged or Global: Paged

Data Length in Bytes: 1

Data Format: Bit Field

Type: R/W

Protectable: Yes

Default Value: 17h (ENABLE pin control, active high, turn off output immediately – no ramp down)

Units: N/A

COMMAND	ON_OFF_CONFIG (02h)							
Format	Bit Field							
Bit Position	7	6	5	4	3	2	1	0
Access	R/W	R/W	R/W	R/W	R/W	R/W	R/W	R/W
Function	See Following Table							
Default Value	0	0	0	1	0	1	1	1

BIT NUMBER	PURPOSE	BIT VALUE	MEANING
7:5	Not Used	000	Not used
4:2	Sets the default to either operate any time power is present or for the on/off to be controlled by ENABLE pin or OPERATION command	000	Not used
		101	Device starts from ENABLE pin only.
		110	Device starts from OPERATION command only.
1	(Polarity of ENABLE pin - not used)	1	Active high only.
0	ENABLE pin action when commanding the unit to turn off	0	Use the configured ramp-down settings ("soft-off").
		1	Turn off the output immediately.

CLEAR_FAULTS (03h)

Definition: Clears all fault bits in all registers and releases the SALRT pin (if asserted) simultaneously. If a fault condition still exists, the bit will reassert immediately. This command will not restart a device if it has shut down, it will only clear the faults.

Paged or Global: Global

Data Length in Bytes: 0 Byte

Data Format: N/A

Type: Write Only

Protectable: Yes

Default Value: N/A

Units: N/A

STORE_DEFAULT_ALL (11h)

Definition: Stores all current PMBus values from the operating memory into the nonvolatile DEFAULT store memory. To clear the DEFAULT store, perform a RESTORE_FACTORY then STORE_DEFAULT_ALL. To add to the DEFAULT store, perform a RESTORE_DEFAULT_ALL, write commands to be added, then STORE_DEFAULT_ALL. This command should not be used during device operation. The device will be unresponsive for 100ms while storing values.

Paged or Global: Global

Data Length in Bytes: 0

Data Format: N/A

Type: Write Only

Default Value: N/A

Units: N/A

RESTORE_DEFAULT_ALL (12h)

Definition: Restores PMBus settings from the nonvolatile DEFAULT store memory into the operating memory. These settings are loaded during power-up if not superseded by settings in USER store. Security level is changed to level 1 following this command. This command should not be used during device operation. The device will be unresponsive for 100ms while storing values.

Paged or Global: Global

Data Length in Bytes: 0

Data Format: N/A

Type: Write Only

Default Value: N/A

Units: N/A

STORE_USER_ALL (15h)

Definition: Stores all PMBus settings from the operating memory to the nonvolatile USER store memory. To clear the USER store, perform a RESTORE_FACTORY then STORE_USER_ALL. To add to the USER store, perform a RESTORE_USER_ALL, write commands to be added, then STORE_USER_ALL. This command should not be used during device operation. The device will be unresponsive for 100ms while storing values.

Paged or Global: Global

Data Length in Bytes: 0

Data Format: N/A

Type: Write Only

Default Value: N/A

Units: N/A

RESTORE_USER_ALL (16h)

Definition: Restores all PMBus settings from the USER store memory to the operating memory. Command performed at power-up. Security level is changed to Level 1 following this command. This command should not be used during device operation. The device will be unresponsive for 100ms while restoring values.

Paged or Global: Global

Data Length in Bytes: 0

Data Format: N/A

Type: Write Only

Default Value: N/A

Units: N/A

VOUT_MODE (20H)

Definition: Reports the V_{OUT} mode and provides the exponent used in calculating several V_{OUT} settings.

Data Length in Bytes: 1

Data Format: BIT

Type: Read Only

Default Value: 13h (Linear Mode, Exponent = -13)

Units: N/A

COMMAND	VOUT_MODE (20h)							
Format	Bit Field							
Bit Position	7	6	5	4	3	2	1	0
Access	R	R	R	R	R	R	R	R
Function	See Following Table							
Default Value	0	0	0	1	0	0	1	1

MODE	BITS 7:5	BITS 4:0 (PARAMETER)
Linear	000	5-bit two's complement exponent for the mantissa delivered as the data bytes for an output voltage related command.

VOUT_COMMAND (21h)

Definition: Sets or reports the target output voltage. The integer value is multiplied by 2 raised to the power of -13h. This command cannot be set to be higher than 115% of the pin-strap VSET setting, or VOUT_MAX if VOUT_MAX is set higher than 115% of the pin-strap VSET setting.

Paged or Global: Paged

Data Length in Bytes: 2

Data Format: Linear -16 Unsigned

Type: R/W

Protectable: Yes

Default Value: VSET pin-strap setting

Units: Volts

Equation: $V_{OUT} = VOUT_COMMAND \times 2^{-13}$

Range: 0 to VOUT_MAX

Example: VOUT_COMMAND = 699Ah = 27,034

Target voltage equals $27034 \times 2^{-13} = 3.3V$

COMMAND	VOUT_COMMAND (21h)															
Format	Linear-16 Unsigned															
Bit Position	15	14	13	12	11	10	9	8	7	6	5	4	3	2	1	0
Access	R/W	R/W	R/W	R/W	R/W	R/W	R/W	R/W	R/W	R/W	R/W	R/W	R/W	R/W	R/W	R/W
Default Value	VSET Pin-strap Setting															

VOUT_TRIM (22h)

Definition: Applies a fixed trim voltage to the output voltage command value. This command is typically used by the manufacturer of a power supply subassembly to calibrate a device in the subassembly circuit. The two bytes are formatted as a two's complement binary mantissa, used in conjunction with the exponent of -13h.

Paged or Global: Paged

Data Length in Bytes: 2

Data Format: Linear -16 Signed

Type: R/W

Protectable: Yes

Default Value: 0000h

Units: Volts

Equation: $VOUT\ trim = VOUT_TRIM \times 2^{-13}$

Range: $\pm 150mV$

COMMAND	VOUT_TRIM (22h)															
Format	Linear-16 Signed															
Bit Position	15	14	13	12	11	10	9	8	7	6	5	4	3	2	1	0
Access	R/W	R/W	R/W	R/W	R/W	R/W	R/W	R/W	R/W	R/W	R/W	R/W	R/W	R/W	R/W	R/W
Default Value	0	0	0	0	0	0	0	0	0	0	0	0	0	0	0	0

VOUT_CAL_OFFSET (23h)

Definition: Applies a fixed offset voltage to the output voltage command value. This command is typically used to calibrate a device in the application circuit. The two bytes are formatted as a two's complement binary mantissa, used in conjunction with the exponent of -13h.

Paged or Global: Paged

Data Length in Bytes: 2

Data Format: Linear -16 Signed

Type: R/W

Protectable: Yes

Default Value: 0000h

Units: Volts

Equation: V_{OUT} calibration offset = $VOUT_CAL_OFFSET \times 2^{-13}$

Range: $\pm 150mV$

COMMAND	VOUT_CAL_OFFSET (23h)															
Format	Linear-16 Signed															
Bit Position	15	14	13	12	11	10	9	8	7	6	5	4	3	2	1	0
Access	R/W	R/W	R/W	R/W	R/W	R/W	R/W	R/W	R/W	R/W	R/W	R/W	R/W	R/W	R/W	R/W
Default Value	0	0	0	0	0	0	0	0	0	0	0	0	0	0	0	0

VOUT_MAX (24h)

Definition: Sets an upper limit on the output voltage the unit can command regardless of any other commands or combinations. The intent of this command is to provide a safeguard against a user accidentally setting the output voltage to a possibly destructive level rather than to be the primary output overprotection. If a VOUT_COMMAND is sent with a value higher than VOUT_MAX, the device will set the output voltage to VOUT_MAX. **Note that this command setting does not automatically scale with a stored VOUT_COMMAND setting.**

Paged or Global: Paged

Data Length in Bytes: 2

Data Format: Linear -16 Unsigned

Type: R/W

Protectable: Yes

Default Value: 1.15 x VSET pin-strap setting

Units: Volts

Equation: $V_{OUT\ max} = VOUT_MAX \times 2^{-13}$

Range: 0V to 5.5V

COMMAND	VOUT_MAX (24h)															
Format	Linear-16 Unsigned															
Bit Position	15	14	13	12	11	10	9	8	7	6	5	4	3	2	1	0
Access	R/W	R/W	R/W	R/W	R/W	R/W	R/W	R/W	R/W	R/W	R/W	R/W	R/W	R/W	R/W	R/W
Default Value	1.15 x VSET Pin-strap Setting															

VOUT_MARGIN_HIGH (25h)

Definition: Sets the value of the V_{OUT} during a margin high. This VOUT_MARGIN_HIGH command loads the unit with the voltage to which the output is to be changed when the OPERATION command is set to “Margin High”.

Paged or Global: Paged

Data Length in Bytes: 2

Data Format: Linear-16 Unsigned

Type: R/W word

Protectable: Yes

Default Value: 1.05 x VSET pin-strap setting

Units: V

Equation: V_{OUT} margin high = VOUT_MARGIN_HIGH x 2^{-13}

Range: 0V to VOUT_MAX

COMMAND	VOUT_MARGIN_HIGH (25h)															
Format	Linear-16 Unsigned															
Bit Position	15	14	13	12	11	10	9	8	7	6	5	4	3	2	1	0
Access	R/W	R/W	R/W	R/W	R/W	R/W	R/W	R/W	R/W	R/W	R/W	R/W	R/W	R/W	R/W	R/W
Default Value	1.05 x VSET Pin-strap Setting															

VOUT_MARGIN_LOW (26h)

Definition: Sets the value of the V_{OUT} during a margin low. This VOUT_MARGIN_LOW command loads the unit with the voltage to which the output is to be changed when the OPERATION command is set to “Margin Low”.

Paged or Global: Paged

Data Length in Bytes: 2

Data Format: Linear-16 Unsigned

Type: R/W

Protectable: Yes

Default Value: 0.95 x VSET pin-strap setting

Units: V

Equation: V_{OUT} margin low = VOUT_MARGIN_LOW

Range: 0V to VOUT_MAX

COMMAND	VOUT_MARGIN_LOW (26h)															
Format	Linear-16 Unsigned															
Bit Position	15	14	13	12	11	10	9	8	7	6	5	4	3	2	1	0
Access	R/W	R/W	R/W	R/W	R/W	R/W	R/W	R/W	R/W	R/W	R/W	R/W	R/W	R/W	R/W	R/W
Default Value	0.95 x VSET Pin-strap Setting															

VOUT_TRANSITION_RATE (27h)

Definition: Sets the rate at which the output should change voltage when the device receives an OPERATION command (Margin High, Margin Low) that causes the output voltage to change. The maximum possible positive value of the two data bytes indicates that the device should make the transition as quickly as possible. This commanded rate does not apply when the device is commanded to turn on or to turn off.

Paged or Global: Paged

Data Length in Bytes: 2

Data Format: Linear-11

Type: R/W

Protectable: Yes

Default Value: BA00h (1.0V/ms)

Units: V/ms

Equation: $VOUT_TRANSITION_RATE = Y \times 2^N$

Range: 0.1 to 4V/ms

COMMAND	VOUT_TRANSITION_RATE (27h)															
Format	Linear-11															
Bit Position	15	14	13	12	11	10	9	8	7	6	5	4	3	2	1	0
Access	R/W	R/W	R/W	R/W	R/W	R/W	R/W	R/W	R/W	R/W	R/W	R/W	R/W	R/W	R/W	R/W
Function	Signed Exponent, N					Signed Mantissa, Y										
Default Value	1	0	1	1	1	0	1	0	0	0	0	0	0	0	0	0

VOUT_DROOP (28h)

Definition: Sets the effective load line (V/I slope) for the rail in which the device is used. It is the rate, in mV/A, at which the output voltage decreases with increasing output current for use with passive current sharing schemes. For devices that are set to sink output current (negative output current), the output voltage continues to increase as the output current is negative. VOUT_DROOP is not needed with a single (2-phase) ZL8802. VOUT_DROOP is needed when multiple ZL8802s are operated in current sharing mode, that is, 4-, 6-, and 8-phase configurations. In this case, VOUT_DROOP is calculated based on the combined output current of all phases as applicable.

Paged or Global: Paged

Data Length in Bytes: 2

Data Format: Linear-11

Type: R/W

Protectable: Yes

Default Value: Set by CFG pin-strap setting

Units: mV/A

Equation: $VOUT_DROOP = Y \times 2^N$

Range: 0 to 40mV/A

COMMAND	VOUT_DROOP (28h)															
Format	Linear-11															
Bit Position	15	14	13	12	11	10	9	8	7	6	5	4	3	2	1	0
Access	R/W	R/W	R/W	R/W	R/W	R/W	R/W	R/W	R/W	R/W	R/W	R/W	R/W	R/W	R/W	R/W
Function	Signed Exponent, N					Signed Mantissa, Y										
Default Value	Set by CFG Pin-strap Setting															

FREQUENCY_SWITCH (33h)

Definition: Sets the switching frequency of the device. Initial default value is defined by a pin-strap and this value can be overridden by writing this command. If an external SYNC is utilized, this value should be set as close as possible to the external clock value. The output must be disabled when writing this command. Available frequencies are defined by the equation $f_{SW} = 16\text{MHz}/n$ where $12 \leq n \leq 80$.

Paged or Global: Global

Data Length in Bytes: 2

Data Format: Linear-11

Type: R/W

Protectable: Yes

Default Value: SYNC pin-strap setting

Units: kHz

Equation: $\text{FREQUENCY_SWITCH} = Y \times 2^N$

Range: 200kHz-1.33MHz

COMMAND	FREQUENCY_SWITCH (33h)															
Format	Linear-11															
Bit Position	15	14	13	12	11	10	9	8	7	6	5	4	3	2	1	0
Access	R/W	R/W	R/W	R/W	R/W	R/W	R/W	R/W	R/W	R/W	R/W	R/W	R/W	R/W	R/W	R/W
Function	Signed Exponent, N								Signed Mantissa, Y							
Default Value	SYNC Pin-strapped Value															

INTERLEAVE (37h)

Definition: Configures the phase offset of a device that is sharing a common SYNC clock with other devices. A desired phase position is specified. Interleave is used for setting the phase offset between individual devices, current sharing groups, and/or combinations of devices and current sharing groups. For devices within single current sharing group the phase offset is set automatically. **In a multiphase current share group the same interleave settings must be stored in all devices in the current sharing group to phase spread properly.** Interleave Offset refers to the phase offset of Phase 0 of the device; Phase 1 is always Phase 0 + 180 degrees.

INTERLEAVE Phase offset is calculated with [Equation 7](#):

$$\text{Phase Offset (in degrees)} = \{\text{Rounded}(\text{Position} \cdot 16/\text{Number})\} \cdot 22.5 \quad (\text{EQ. 7})$$

Phase offsets greater than 360 degrees are “wrapped around” by subtracting 360 degrees.

Paged or Global: Paged

Data Length in Bytes: 2

Data Format: Bit Field

Type: R/W

Protectable: Yes

Default Value: Set by CFG pin-strap setting.

Units: N/A

COMMAND	INTERLEAVE (37h)															
Format	Bit Field															
Bit Position	15	14	13	12	11	10	9	8	7	6	5	4	3	2	1	0
Access	R/W	R/W	R/W	R/W	R/W	R/W	R/W	R/W	R/W	R/W	R/W	R/W	R/W	R/W	R/W	R/W
Function	See Following Table															
Default Value	Set by CFG Pin-strap Setting															

BITS	PURPOSE	VALUE	DESCRIPTION
15:8	Not Used	0	Not used
7:4	Number In Group	0 to 15d	Sets the number of devices in the interleave group. A value of 0 is interpreted as 16.
3:0	Position in Group (Interleave Order)	0 to 15d	Sets position of the device's rail within the group. A value of 0 is interpreted as 16. Position 1 will have a 22.5 degree offset.

IOUT_CAL_GAIN (38h)

Definition: Sets the effective impedance across the current sense circuit for use in calculating output current at +25°C.

Paged or Global: Paged

Data Length in Bytes: 2

Data Format: Linear-11

Type: R/W

Protectable: Yes

Default Value: B2AEh (0.67mΩ)

Units: mΩ

Equation: $IOUT_CAL_GAIN = Y \times 2^N$

COMMAND	IOUT_CAL_GAIN (38h)															
Format	Linear-11															
Bit Position	15	14	13	12	11	10	9	8	7	6	5	4	3	2	1	0
Access	R/W	R/W	R/W	R/W	R/W	R/W	R/W	R/W	R/W	R/W	R/W	R/W	R/W	R/W	R/W	R/W
Function	Signed Exponent, N					Signed Mantissa, Y										
Default Value	1	0	1	1	0	0	1	0	1	0	1	0	1	1	1	0

IOUT_CAL_OFFSET (39h)

Definition: Used to null out any offsets in the output current sensing circuit, and to compensate for delayed measurements of current ramp due to the current sense blanking time (see "[ISENSE_CONFIG \(D0h\)](#)" on page 62).

Paged or Global: Paged

Data Length in Bytes: 2

Data Format: Linear-11

Type: R/W

Protectable: Yes

Default Value: BD00h (-1.5A)

Units: A

Equation: $IOUT_CAL_OFFSET = Y \times 2^N$

COMMAND	IOUT_CAL_OFFSET (39h)															
Format	Linear-11															
Bit Position	15	14	13	12	11	10	9	8	7	6	5	4	3	2	1	0
Access	R/W	R/W	R/W	R/W	R/W	R/W	R/W	R/W	R/W	R/W	R/W	R/W	R/W	R/W	R/W	R/W
Function	Signed Exponent, N					Signed Mantissa, Y										
Default Value	1	0	1	1	1	1	0	1	0	0	0	0	0	0	0	0

VOUT_OV_FAULT_LIMIT (40h)**Definition:** Sets the V_{OUT} overvoltage fault threshold.**Paged or Global:** Paged**Data Length in Bytes:** 2**Data Format:** Linear-16 Unsigned**Type:** R/W**Protectable:** Yes**Default Value:** 1.10 x VSET pin-strap setting**Units:** V**Equation:** VOUT OV fault limit = VOUT_OV_FAULT_LIMIT×2⁻¹³**Range:** 0V to 7.99V

COMMAND	VOUT_OV_FAULT_LIMIT (40h)															
Format	Linear-16 Unsigned															
Bit Position	15	14	13	12	11	10	9	8	7	6	5	4	3	2	1	0
Access	R/W	R/W	R/W	R/W	R/W	R/W	R/W	R/W	R/W	R/W	R/W	R/W	R/W	R/W	R/W	R/W
Default Value	1.10 x VSET Pin-strap Setting															

VOUT_OV_FAULT_RESPONSE (41h)**Definition:** Configures the V_{OUT} overvoltage fault response. The retry time is the time between restart attempts.**Paged or Global:** Paged**Data Length in Bytes:** 1**Data Format:** Bit Field**Type:** R/W**Protectable:** Yes**Default Value:** 80h (shut down immediately, no retries)**Units:** Retry time = 35ms increments

COMMAND	VOUT_OV_FAULT_RESPONSE (41h)							
Format	Bit Field							
Bit Position	7	6	5	4	3	2	1	0
Access	R/W	R/W	R/W	R/W	R/W	R/W	R/W	R/W
Function	See Following Table							
Default Value	1	0	0	0	0	0	0	0

BIT	FIELD NAME	VALUE	DESCRIPTION
7:6	Response behavior, the device: • Pulls SALRT low • Sets the related fault bit in the status registers. Fault bits are only cleared by the CLEAR_FAULTS command.	00-01	Not used
		10-11	Disable and retry according to the setting in Bits [5:3].
5:3	Retry Setting	000	No retry. The output remains disabled until the device is restarted.
		001-110	Not used
		111	Attempts to restart continuously, until it is commanded OFF (by the ENABLE pin or OPERATION command or both), bias power is removed, or another fault condition causes the unit to shut down. The time between the start of each attempt to restart is set by the value in Bits [2:0] multiplied by 35ms.
2:0	Retry Delay	000-111	Retry delay time = (Value +1)*35ms. Sets the time between retries in 35ms increments. Range is 35ms to 280ms.

VOUT_UV_FAULT_LIMIT (44h)

Definition: Sets the V_{OUT} undervoltage fault threshold. This fault is masked during ramp, before Power-Good is asserted or when the device is disabled. VOUT_UV_FAULT_LIMIT should be set to a value below POWER_GOOD.

Paged or Global: Paged

Data Length in Bytes: 2

Data Format: Linear-16 Unsigned

Type: R/W

Protectable: Yes

Default Value: 0.85 x VSET pin-strap setting

Units: V

Equation: V_{OUT} UV fault limit = VOUT_UV_FAULT_LIMIT $\times 2^{-13}$

Range: 0V to 7.99V

COMMAND	VOUT_UV_FAULT_LIMIT (44h)															
Format	Linear-16 Unsigned															
Bit Position	15	14	13	12	11	10	9	8	7	6	5	4	3	2	1	0
Access	R/W	R/W	R/W	R/W	R/W	R/W	R/W	R/W	R/W	R/W	R/W	R/W	R/W	R/W	R/W	R/W
Default Value	0.85 x VSET Pin-strap Setting															

VOUT_UV_FAULT_RESPONSE (45h)

Definition: Configures the V_{OUT} undervoltage fault response. Note that V_{OUT} UV faults can only occur after Power-Good (PG) has been asserted. Under some circumstances this will cause the output to stay fixed below the Power-Good threshold indefinitely. If this behavior is undesired, use setting 80h. The retry time is the time between restart attempts.

Paged or Global: Paged

Data Length in Bytes: 1

Data Format: Bit Field

Type: R/W

Protectable: Yes

Default Value: 80h (shut down immediately, no retries)

Units: Retry time unit = 35ms

COMMAND	VOUT_UV_FAULT_RESPONSE (45h)								
Format	Bit Field								
Bit Position	7	6	5	4	3	2	1	0	
Access	R/W	R/W	R/W	R/W	R/W	R/W	R/W	R/W	R/W
Function	See Following Table								
Default Value	1	0	0	0	0	0	0	0	0

BIT	FIELD NAME	VALUE	DESCRIPTION
7:6	Response Behavior: the device: • Pulls SALRT low • Sets the related fault bit in the status registers. Fault bits are only cleared by the CLEAR_FAULTS command.	00-01	Not used
		10-11	Disable and Retry according to the setting in Bits [5:3].
5:3	Retry Setting	000	No retry. The output remains disabled until the fault is cleared.
		001-110	Not used
		111	Attempts to restart continuously, until it is commanded OFF (by the ENABLE pin or OPERATION command or both), bias power is removed, or another fault condition causes the unit to shut down. The time between the start of each attempt to restart is set by the value in Bits [2:0] multiplied by 35ms.
2:0	Retry Delay	000-111	Retry delay time = (Value +1)*35ms. Sets the time between retries in 35ms increments. Range is 35ms to 280ms.

IOUT_OC_FAULT_LIMIT (46h)

Definition: Sets the I_{OUT} peak overcurrent fault threshold. This limit is applied to current measurement samples taken after the Current Sense Blanking Time has expired (see [“ISENSE_CONFIG \(D0h\)” on page 62](#)). A fault occurs after this limit is exceeded for the number of consecutive samples as defined in ISENSE_CONFIG. This feature shares the OC fault bit operation (in STATUS_IOUT) and OC fault response with IOUT_AVG_OC_FAULT_LIMIT.

Paged or Global: Paged

Data Length in Bytes: 2

Data Format: Linear-11

Type: R/W

Protectable: Yes

Default Value: CFG pin-strap setting

Units: A

Equation: $IOUT_OC_FAULT_LIMIT = Y \times 2^N$

Range: -100A to 100A

COMMAND	IOUT_OC_FAULT_LIMIT (46h)															
Format	Linear-11															
Bit Position	15	14	13	12	11	10	9	8	7	6	5	4	3	2	1	0
Access	R/W	R/W	R/W	R/W	R/W	R/W	R/W	R/W	R/W	R/W	R/W	R/W	R/W	R/W	R/W	R/W
Function	Signed Exponent, N								Signed Mantissa, Y							
Default Value	CFG Pin-strap Setting															

IOUT_UC_FAULT_LIMIT (4Bh)

Definition: Sets the I_{OUT} valley undercurrent fault threshold. This limit is applied to current measurement samples taken after the Current Sense Blanking Time has expired. A fault occurs after this limit is exceeded for the number of consecutive sample as defined in ISENSE_CONFIG. This feature shares the UC fault bit operation (in STATUS_IOUT) and UC fault response with IOUT_AVG_UC_FAULT_LIMIT.

Paged or Global: Paged

Data Length in Bytes: 2

Data Format: Linear-11

Type: R/W

Protectable: Yes

Default Value: -1 * IOUT_OC_FAULT_LIMIT from CFG pin-strap setting

Units: A

Equation: $IOUT_UC_FAULT_LIMIT = Y \times 2^N$

Range: -100A to 100A

COMMAND	IOUT_UC_FAULT_LIMIT (4Bh)															
Format	Linear-11															
Bit Position	15	14	13	12	11	10	9	8	7	6	5	4	3	2	1	0
Access	R/W	R/W	R/W	R/W	R/W	R/W	R/W	R/W	R/W	R/W	R/W	R/W	R/W	R/W	R/W	R/W
Function	Signed Exponent, N								Signed Mantissa, Y							
Default Value	-1 * IOUT_OC_FAULT_LIMIT from CFG Pin-strap Setting															

OT_FAULT_LIMIT (4Fh)

Definition: Sets the temperature at which the device should indicate an over-temperature fault.

Paged or Global: Paged

Data Length in Bytes: 2

Data Format: Linear-11

Type: R/W

Protectable: Yes

Default Value: EBE8h (+125°C)

Units: Celsius

Equation: $OT_FAULT_LIMIT = Y \times 2^N$

Range: 0 to 175°C

COMMAND	OT_FAULT_LIMIT (4Fh)															
Format	Linear-11															
Bit Position	15	14	13	12	11	10	9	8	7	6	5	4	3	2	1	0
Access	R/W	R/W	R/W	R/W	R/W	R/W	R/W	R/W	R/W	R/W	R/W	R/W	R/W	R/W	R/W	R/W
Function	Signed Exponent, N								Signed Mantissa, Y							
Default Value	1	1	1	0	1	0	1	1	1	1	1	0	1	0	0	0

OT_FAULT_RESPONSE (50h)

Definition: Instructs the device on what action to take in response to an over-temperature fault. The retry time is the time between restart attempts.

Paged or Global: Paged

Data Length in Bytes: 1

Data Format: Bit Field

Type: R/W

Protectable: Yes

Default Value: BFh (Continuous retries, retry delay 280ms)

Units: Retry time unit = 35ms

COMMAND	OT_FAULT_RESPONSE (50h)							
Format	Bit Field							
Bit Position	7	6	5	4	3	2	1	0
Access	R/W	R/W	R/W	R/W	R/W	R/W	R/W	R/W
Function	See Following Table							
Default Value	1	0	1	1	1	1	1	1

BIT	FIELD NAME	VALUE	DESCRIPTION
7:6	Response behavior, the device: • Pulls SALRT low • Sets the related fault bit in the status registers. Fault bits are only cleared by the CLEAR_FAULTS command.	00-01	Not used
		10	Disable and Retry according to the setting in Bits [5:3].
		11	Output is disabled while the fault is present. Operation resumes and the output is enabled when the temperature falls below the OT_WARN_LIMIT.
5:3	Retry Setting	000	No retry. The output remains disabled until the fault is cleared.
		001-110	Not used
		111	Attempts to restart continuously, until it is commanded OFF (by the ENABLE pin or OPERATION command or both), bias power is removed, or another fault condition causes the unit to shut down. A retry is attempted after the temperature falls below the OT_WARN_LIMIT. The time between the start of each attempt to restart is set by the value in Bits [2:0] multiplied by 35ms.
2:0	Retry Delay	000-111	Retry delay time = (Value +1)*35ms. Sets the time between retries in 35ms increments. Range is 35ms to 280ms.

OT_WARN_LIMIT (51h)

Definition: Sets the temperature at which the device should indicate an over-temperature warning alarm. In response to the OT_WARN_LIMIT being exceeded, the device sets the TEMPERATURE bit in STATUS_WORD, sets the OT_WARNING bit in STATUS_TEMPERATURE, and notifies the host.

Paged or Global: Paged

Data Length in Bytes: 2

Data Format: Linear-11

Type: R/W

Protectable: Yes

Default Value: EB70h (+110 °C)

Units: Celsius

Equation: $OT_WARN_LIMIT = Y \times 2^N$

Range: 0 to 175 °C

COMMAND	OT_WARN_LIMIT (51h)															
Format	Linear-11															
Bit Position	15	14	13	12	11	10	9	8	7	6	5	4	3	2	1	0
Access	R/W	R/W	R/W	R/W	R/W	R/W	R/W	R/W	R/W	R/W	R/W	R/W	R/W	R/W	R/W	R/W
Function	Signed Exponent, N					Signed Mantissa, Y										
Default Value	1	1	1	0	1	0	1	1	0	1	1	1	0	0	0	0

UT_WARN_LIMIT (52h)

Definition: Sets the temperature at which the device should indicate an under-temperature warning alarm. In response to the UT_WARN_LIMIT being exceeded, the device sets the TEMPERATURE bit in STATUS_WORD, sets the UT_WARNING bit in STATUS_TEMPERATURE, and notifies the host.

Paged or Global: Paged

Data Length in Bytes: 2

Data Format: Linear-11

Type: R/W

Protectable: Yes

Default Value: DC40h (-30 °C)

Units: Celsius

Equation: $UT_WARN_LIMIT = Y \times 2^N$

Range: -55 °C to +25 °C

COMMAND	UT_WARN_LIMIT (52h)															
Format	Linear-11															
Bit Position	15	14	13	12	11	10	9	8	7	6	5	4	3	2	1	0
Access	R/W	R/W	R/W	R/W	R/W	R/W	R/W	R/W	R/W	R/W	R/W	R/W	R/W	R/W	R/W	R/W
Function	Signed Exponent, N					Signed Mantissa, Y										
Default Value	1	1	0	1	1	1	0	0	0	0	1	0	0	0	0	0

UT_FAULT_LIMIT (53h)

Definition: Sets the temperature, in degrees Celsius, of the unit at which it should indicate an under-temperature fault.

Paged or Global: Paged

Data Length in Bytes: 2

Data Format: Linear-11

Type: R/W

Protectable: Yes

Default Value: E530h (-45°C)

Units: Celsius

Equation: $UT_FAULT_LIMIT = Y \times 2^N$

Range: -55°C to +25°C

COMMAND	UT_FAULT_LIMIT (53h)															
Format	Linear-11															
Bit Position	15	14	13	12	11	10	9	8	7	6	5	4	3	2	1	0
Access	R/W	R/W	R/W	R/W	R/W	R/W	R/W	R/W	R/W	R/W	R/W	R/W	R/W	R/W	R/W	R/W
Function	Signed Exponent, N								Signed Mantissa, Y							
Default Value	1	1	1	0	0	1	0	1	0	0	1	1	0	0	0	0

UT_FAULT_RESPONSE (54h)

Definition: Configures the under-temperature fault response as defined by the table below. The retry time is the time between restart attempts.

Paged or Global: Paged

Data Length in Bytes: 1

Data Format: Bit Field

Type: R/W

Protectable: Yes

Default Value: BFh (Continuous retries, 280ms retry delay)

Units: Retry time unit = 35ms

COMMAND	UT_FAULT_RESPONSE (54h)							
Format	Bit Field							
Bit Position	7	6	5	4	3	2	1	0
Access	R/W	R/W	R/W	R/W	R/W	R/W	R/W	R/W
Function	See Following Table							
Default Value	1	0	1	1	1	1	1	1

BIT	FIELD NAME	VALUE	DESCRIPTION
7:6	Response behavior, the device: <ul style="list-style-type: none"> Pulls SALRT low Sets the related fault bit in the status registers. Fault bits are only cleared by the CLEAR_FAULTS command. 	00-01	Not used
		10	Disable and Retry according to the setting in Bits [5:3].
		11	Output is disabled while the fault is present. Operation resumes and the output is enabled when the temperature rises above the UT_WARN_LIMIT.
5:3	Retry Setting	000	No retry. The output remains disabled until the device is restarted.
		001-110	Not used
		111	Attempts to restart continuously, until it is commanded OFF (by the ENABLE pin or OPERATION command or both), bias power is removed, or another fault condition causes the unit to shut down. A retry is attempted after the temperature rises above UT_WARN_LIMIT. The time between the start of each attempt to restart is set by the value in Bits [2:0] multiplied by 35ms.
2:0	Retry Delay	000-111	Retry delay time = (Value +1)*35ms. Sets the time between retries in 35ms increments. Range is 35ms to 280ms.

VIN_OV_FAULT_LIMIT (55h)**Definition:** Sets the V_{IN} overvoltage fault threshold.**Paged or Global:** Global**Data Length in Bytes:** 2**Data Format:** Linear-11**Type:** R/W**Protectable:** Yes**Default Value:** D380h (14V)**Units:** V**Equation:** $VIN_OV_FAULT_LIMIT = Y \times 2^N$ **Range:** 0 to 19V

COMMAND	VIN_OV_FAULT_LIMIT (55h)															
Format	Linear-11															
Bit Position	15	14	13	12	11	10	9	8	7	6	5	4	3	2	1	0
Access	R/W	R/W	R/W	R/W	R/W	R/W	R/W	R/W	R/W	R/W	R/W	R/W	R/W	R/W	R/W	R/W
Function	Signed Exponent, N								Signed Mantissa, Y							
Default Value	1	1	0	1	0	0	1	1	1	0	0	0	0	0	0	0

VIN_OV_FAULT_RESPONSE (56h)**Definition:** Configures the V_{IN} overvoltage fault response as defined by the table below.**Paged or Global:** Global**Data Length in Bytes:** 1**Data Format:** Bit Field**Type:** R/W**Protectable:** Yes**Default Value:** 80h (Disable, no retry)**Units:** N/A

COMMAND	VIN_OV_FAULT_RESPONSE (56h)							
Format	Bit Field							
Bit Position	7	6	5	4	3	2	1	0
Access	R/W	R/W	R/W	R/W	R/W	R/W	R/W	R/W
Function	See Following Table							
Default Value	1	0	0	0	0	0	0	0

BIT	FIELD NAME	VALUE	DESCRIPTION
7:6	Response behavior, the device: • Pulls SALRT low • Sets the related fault bit in the status registers. Fault bits are only cleared by the CLEAR_FAULTS command.	00-01	Not used
		10	Disable and Retry according to the setting in bits [5:3].
		11	Output is disabled while the fault is present. Operation resumes and the output is enabled when VIN falls below the VIN_OV_WARN_LIMIT.
5:3	Retry Setting	000	No retry. The output remains disabled until the fault is cleared.
		001-110	Not used
		111	Attempts to restart continuously, until it is commanded OFF (by the ENABLE pin or OPERATION command or both), bias power is removed, or another fault condition causes the unit to shut down. A retry is attempted after the output falls below the VIN_OV_WARN_LIMIT. The time between the start of each attempt to restart is set by the value in bits [2:0] multiplied by 35ms.
2:0	Retry Delay	000-111	Retry delay time = (Value + 1) * 35ms. Sets the time between retries in 35ms increments. Range is 35ms to 280ms.

VIN_OV_WARN_LIMIT (57h)

Definition: Sets the V_{IN} overvoltage warning threshold as defined by the table below. In response to the OV_WARN_LIMIT being exceeded, the device sets the NONE OF THE ABOVE and INPUT bits in STATUS_WORD, sets the VIN_OV_WARNING bit in STATUS_INPUT, and notifies the host.

Paged or Global: Global

Data Length in Bytes: 2

Data Format: Linear-11

Type: R/W

Protectable: Yes

Default Value: D360h (13.5V)

Units: V

Equation: $VIN_OV_FAULT_LIMIT = Y \times 2^N$

Range: 0 to 19V

COMMAND	VIN_OV_WARN_LIMIT (57h)															
Format	Linear-11															
Bit Position	15	14	13	12	11	10	9	8	7	6	5	4	3	2	1	0
Access	R/W	R/W	R/W	R/W	R/W	R/W	R/W	R/W	R/W	R/W	R/W	R/W	R/W	R/W	R/W	R/W
Function	Signed Exponent, N								Signed Mantissa, Y							
Default Value	1	1	0	1	0	0	1	1	0	1	1	0	0	0	0	0

VIN_UV_WARN_LIMIT (58h)

Definition: Sets the VIN undervoltage warning threshold. If a VIN_UV_FAULT occurs, the input voltage must rise above VIN_UV_WARN_LIMIT to clear the fault, which provides hysteresis to the fault threshold. In response to the UV_WARN_LIMIT being exceeded, the device sets the NONE OF THE ABOVE and INPUT bits in STATUS_WORD, sets the VIN_UV_WARNING bit in STATUS_INPUT, and notifies the host.

Paged or Global: Global

Data Length in Bytes: 2

Data Format: Linear-11

Type: R/W

Protectable: Yes

Default Value: 1.10 x UVLO pin-strap setting

Units: V

Equation: $VIN_UV_WARN_LIMIT = Y \times 2^N$

Range: 0 to 19V

COMMAND	VIN_UV_WARN_LIMIT (58h)															
Format	Linear-11															
Bit Position	15	14	13	12	11	10	9	8	7	6	5	4	3	2	1	0
Access	R/W	R/W	R/W	R/W	R/W	R/W	R/W	R/W	R/W	R/W	R/W	R/W	R/W	R/W	R/W	R/W
Function	Signed Exponent, N								Signed Mantissa, Y							
Default Value	1.10 x UVLO Pin-strap Setting															

VIN_UV_FAULT_LIMIT (59h)**Definition:** Sets the V_{IN} undervoltage fault threshold.**Paged or Global:** Global**Data Length in Bytes:** 2**Data Format:** Linear-11**Type:** R/W**Protectable:** Yes**Default Value:** UVLO pin-strap setting**Units:** V**Equation:** $VIN_UV_FAULT_LIMIT = Y \times 2^N$ **Range:** 0 to 19V

COMMAND	VIN_UV_FAULT_LIMIT (59h)															
Format	Linear-11															
Bit Position	15	14	13	12	11	10	9	8	7	6	5	4	3	2	1	0
Access	R/W	R/W	R/W	R/W	R/W	R/W	R/W	R/W	R/W	R/W	R/W	R/W	R/W	R/W	R/W	R/W
Function	Signed Exponent, N						Signed Mantissa, Y									
Default Value	UVLO pin-straped value															

VIN_UV_FAULT_RESPONSE (5Ah)**Definition:** Configures the VIN undervoltage fault response as defined by the table below. The retry time is the time between restart attempts.**Paged or Global:** Global**Data Length in Bytes:** 1**Data Format:** Bit Field**Type:** R/W**Protectable:** Yes**Default Value:** BFh (continuous retries, 280ms retry delay)**Units:** Retry time unit = 35ms

COMMAND	VIN_UV_FAULT_RESPONSE (5Ah)							
Format	Bit Field							
Bit Position	7	6	5	4	3	2	1	0
Access	R/W	R/W	R/W	R/W	R/W	R/W	R/W	R/W
Function	See Following Table							
Default Value	1	0	0	0	0	0	0	0

BIT	FIELD NAME	VALUE	DESCRIPTION
7:6	Response behavior, the device: • Pulls SALRT low • Sets the related fault bit in the status registers. Fault bits are only cleared by the CLEAR_FAULTS command.	00-01	Not used
		10	Disable and retry according to the setting in Bits [5:3].
		11	Output is disabled while the fault is present. Operation resumes and the output is enabled when V_{IN} rises above the VIN_UV_WARN_LIMIT.
5:3	Retry Setting	000	No retry. The output remains disabled until the fault is cleared.
		001-110	Not used
		111	Attempts to restart continuously, until it is commanded OFF (by the ENABLE pin or OPERATION command or both), bias power is removed, or another fault condition causes the unit to shut down. A retry is attempted after the input voltage rises above the VIN_UV_WARN_LIMIT. The time between the start of each attempt to restart is set by the value in Bits [2:0] multiplied by 35ms.
2:0	Retry Delay	000-111	Retry delay time = (Value +1)*35ms. Sets the time between retries in 35ms increments. Range is 35ms to 280ms.

POWER_GOOD_ON (5Eh)

Definition: Sets the voltage threshold for Power-Good indication. Power-good asserts when the output voltage exceeds POWER_GOOD_ON and deasserts when the output voltage is less than VOUT_UV_FAULT_LIMIT. POWER_GOOD_ON should be set to a value above VOUT_UV_FAULT_LIMIT.

Paged or Global: Paged

Data Length in Bytes: 2

Data Format: Linear-16 Unsigned

Type: R/W

Protectable: Yes

Default Value: 0.9 x VSET pin-strap setting.

Units: V

COMMAND	POWER_GOOD_ON (5Eh)															
Format	Linear-16 Unsigned															
Bit Position	15	14	13	12	11	10	9	8	7	6	5	4	3	2	1	0
Access	R/W	R/W	R/W	R/W	R/W	R/W	R/W	R/W	R/W	R/W	R/W	R/W	R/W	R/W	R/W	R/W
Default Value	0.9 x VSET Pin-strap Setting															

TON_DELAY (60h)

Definition: Sets the delay time from when the device is enabled to the start of V_{OUT} rise.

Paged or Global: Paged

Data Length in Bytes: 2

Data Format: Linear-11

Type: R/W

Protectable: Yes

Default Value: CA80h (5ms)

Units: ms

Equation: TON_DELAY = Y × 2^N

Range: 0 to 5 seconds

COMMAND	TON_DELAY (60h)															
Format	Linear-11															
Bit Position	15	14	13	12	11	10	9	8	7	6	5	4	3	2	1	0
Access	R/W	R/W	R/W	R/W	R/W	R/W	R/W	R/W	R/W	R/W	R/W	R/W	R/W	R/W	R/W	R/W
Function	Signed Exponent, N					Signed Mantissa, Y										
Default Value	1	1	0	0	1	0	1	0	1	0	0	0	0	0	0	0

TON_RISE (61h)

Definition: Sets the rise time of VOUT after ENABLE and TON_DELAY for single and dual channel operation. To adjust the rise time in 4-, 6- or 8-phase operation, use MULTI_PHASE_RAMP_GAIN (D5h).

Paged or Global: Paged

Data Length in Bytes: 2

Data Format: Linear-11

Type: R/W

Protectable: Yes

Default Value: CA80h (5ms)

Units: ms

Equation: $TON_RISE = Y \times 2^N$

Range: 0 to 100ms. Although values can be set below 0.50ms, rise time accuracy cannot be guaranteed. In addition, short rise times may cause excessive input and output currents to flow, thus triggering overcurrent faults at start-up.

COMMAND	TON_RISE (61h)															
Format	Linear-11															
Bit Position	15	14	13	12	11	10	9	8	7	6	5	4	3	2	1	0
Access	R/W	R/W	R/W	R/W	R/W	R/W	R/W	R/W	R/W	R/W	R/W	R/W	R/W	R/W	R/W	R/W
Function	Signed Exponent, N					Signed Mantissa, Y										
Default Value	1	1	0	0	1	0	1	0	1	0	0	0	0	0	0	0

TOFF_DELAY (64h)

Definition: Sets the delay time from DISABLE to start of VOUT fall.

Paged or Global: Paged

Data Length in Bytes: 2

Data Format: Linear-11

Type: R/W

Protectable: Yes

Default Value: CA80h (5ms)

Units: ms

Equation: $TON_DELAY = Y \times 2^N$

Range: 0 to 5 seconds

COMMAND	TOFF_DELAY (64h)															
Format	Linear-11															
Bit Position	15	14	13	12	11	10	9	8	7	6	5	4	3	2	1	0
Access	R/W	R/W	R/W	R/W	R/W	R/W	R/W	R/W	R/W	R/W	R/W	R/W	R/W	R/W	R/W	R/W
Function	Signed Exponent, N					Signed Mantissa, Y										
Default Value	1	1	0	0	1	0	1	0	1	0	0	0	0	0	0	0

TOFF_FALL (65h)

Definition: Sets the fall time for V_{OUT} after DISABLE and TOFF_DELAY. This setting is only valid in single or 2-phase operation. Setting the TOFF_FALL to values less than 0.5ms will cause the ZL8802 to turn-off both the high and low-side FETs (or disable the DrMOS device) immediately after the expiration of the TOFF_DELAY time. In 4-, 6- or 8-phase operation, the ZL8802 will always turn-off both the high and low-side FETs (or disable the DrMOS device) immediately after the expiration of the TOFF_DELAY time.

Paged or Global: Paged

Data Length in Bytes: 2

Data Format: Linear-11

Type: R/W

Protectable: Yes

Default Value: CA80h (5ms)

Units: ms

Equation: $TOFF_FALL = Y \times 2^N$

Range: 0 to 100ms. Values less than 0.5ms will cause the ZL8802 to tri-state the PWM signal (turn-off both the high and low-side FETs) immediately after the expiration of the TOFF_DELAY time.

COMMAND	TOFF_FALL (65h)															
Format	Linear-11															
Bit Position	15	14	13	12	11	10	9	8	7	6	5	4	3	2	1	0
Access	R/W	R/W	R/W	R/W	R/W	R/W	R/W	R/W	R/W	R/W	R/W	R/W	R/W	R/W	R/W	R/W
Function	Signed Exponent, N					Signed Mantissa, Y										
Default Value	1	1	0	0	1	0	1	0	1	0	0	0	0	0	0	0

STATUS_BYTE (78h)

Definition: Returns two bytes of information with a summary of the unit's fault condition. Based on the information in these bytes, the host can get more information by reading the appropriate status registers. The low byte of the STATUS_WORD is the same register as the STATUS_BYTE (78h) command.

Paged or Global: Paged

Data Length in Bytes: 2

Data Format: Bit Field

Type: Read Only

Protectable: No

Default Value: 00h

Units: N/A

COMMAND	STATUS_BYTE (78h)							
Format	Bit Field							
Bit Position	7	6	5	4	3	2	1	0
Access	R	R	R	R	R	R	R	R
Function	See Following Table							
Default Value	0	0	0	0	0	0	0	0

BIT NUMBER	STATUS BIT NAME	MEANING
7	BUSY	A fault was declared because the device was busy and unable to respond.
6	OFF	This bit is asserted if the unit is not providing power to the output, regardless of the reason, including simply not being enabled.
5	VOUT_OV_FAULT	An output overvoltage fault has occurred.
4	IOUT_OC_FAULT	An output overcurrent fault has occurred.
3	VIN_UV_FAULT	An input undervoltage fault has occurred.
2	TEMPERATURE	A temperature fault or warning has occurred.
1	CML	A communications, memory, or logic fault has occurred.
0	None of the above	A fault other than the faults listed in Bits 7:1 above has occurred. The source of the fault will be in bits 15:8 of the STATUS_WORD

STATUS_WORD (79h)

Definition: Returns two bytes of information with a summary of the unit's fault condition. Based on the information in these bytes, the host can get more information by reading the appropriate status registers. The low byte of the STATUS_WORD is the same register as the STATUS_BYTE (78h) command.

Paged or Global: Paged

Data Length in Bytes: 2

Data Format: Bit Field

Type: Read Only

Protectable: No

Default Value: 0000h

Units: N/A

COMMAND	STATUS_WORD (79h)															
Format	Bit Field															
Bit Position	15	14	13	12	11	10	9	8	7	6	5	4	3	2	1	0
Access	R	R	R	R	R	R	R	R	R	R	R	R	R	R	R	R
Function	See Following Table															
Default Value	0	0	0	0	0	0	0	0	0	0	0	0	0	0	0	0

BIT NUMBER	STATUS BIT NAME	MEANING
15	VOUT	An output voltage fault or warning has occurred.
14	IOUT	An output current fault has occurred.
13	INPUT	An input voltage fault or warning has occurred.
12	MFG_SPECIFIC	A manufacturer specific fault or warning has occurred.
11	POWER_GOOD #	The POWER_GOOD signal, if present, is negated. (Note 15)
10	NOT USED	Not used
9	OTHER	A bit in STATUS_VOUT, STATUS_IOUT, STATUS_INPUT, STATUS_TEMPERATURE, STATUS_CML, or STATUS_MFR_SPECIFIC is set.
8	Not Used	Not used
7	BUSY	A fault was declared because the device was busy and unable to respond.
6	OFF	This bit is asserted if the unit is not providing power to the output, regardless of the reason, including simply not being enabled.
5	VOUT_OV_FAULT	An output overvoltage fault has occurred.
4	IOUT_OC_FAULT	An output overcurrent fault has occurred.
3	VIN_UV_FAULT	An input undervoltage fault has occurred.
2	TEMPERATURE	A temperature fault or warning has occurred.
1	CML	A communications, memory, or logic fault has occurred.
0	None of the above	A fault other than the faults listed in Bits 7:1 above has occurred. The source of the fault will be in Bits 15:8 of the STATUS_WORD

NOTE:

15. If the POWER_GOOD# bit is set, this indicates that the POWER_GOOD signal, if present, is signaling that the output power is not good.

STATUS_VOUT (7Ah)**Definition:** Returns one data byte with the status of the output voltage.**Paged or Global:** Paged**Data Length in Bytes:** 1**Data Format:** Bit Field**Type:** Read Only**Protectable:** No**Default Value:** 00h**Units:** N/A

COMMAND	STATUS_VOUT (7Ah)							
Format	Bit Field							
Bit Position	7	6	5	4	3	2	1	0
Access	R	R	R	R	R	R	R	R
Function	See Following Table							
Default Value	0	0	0	0	0	0	0	0

BIT NUMBER	STATUS BIT NAME	MEANING
7	VOUT_OV_FAULT	Indicates an output overvoltage fault.
6	VOUT_OV_WARNING	Not used
5	VOUT_UV_WARNING	Not used
4	VOUT_UV_FAULT	Indicates an output undervoltage fault.
3:0	Not Used	Not used

STATUS_IOUT (7Bh)**Definition:** Returns one data byte with the status of the output current.**Paged or Global:** Paged**Data Length in Bytes:** 1**Data Format:** Bit Field**Type:** Read Only**Protectable:** No**Default Value:** 00h**Units:** N/A

COMMAND	STATUS_IOUT (7Bh)							
Format	Bit Field							
Bit Position	7	6	5	4	3	2	1	0
Access	R	R	R	R	R	R	R	R
Function	See Following Table							
Default Value	0	0	0	0	0	0	0	0

BIT NUMBER	STATUS BIT NAME	MEANING
7	IOUT_OC_FAULT	An output overcurrent fault has occurred.
6	Not Used	Not used
5	Not Used	Not used
4	IOUT_UC_FAULT	An output undercurrent fault has occurred.
3:0	Not Used	Not used

STATUS_INPUT (7Ch)**Definition:** Returns input voltage and input current status information.**Paged or Global:** Global**Data Length in Bytes:** 1**Data Format:** Bit Field**Type:** Read-only**Protectable:** No**Default Value:** 00h**Units:** N/A

COMMAND	STATUS_INPUT (7Ch)							
Format	Bit Field							
Bit Position	7	6	5	4	3	2	1	0
Access	R	R	R	R	R	R	R	R
Function	See Following Table							
Default Value	0	0	0	0	0	0	0	0

BIT NUMBER	STATUS BIT NAME	MEANING
7	VIN_OV_FAULT	An input overvoltage fault has occurred.
6	VIN_OV_WARNING	An input overvoltage warning has occurred.
5	VIN_UV_WARNING	An input undervoltage warning has occurred.
4	VIN_UV_FAULT	An input undervoltage fault has occurred.
3:0	Not Used	Not used

STATUS_TEMPERATURE (7Dh)**Definition:** Returns one byte of information with a summary of any temperature related faults or warnings.**Paged or Global:** Paged**Data Length in Bytes:** 1**Data Format:** Bit Field**Type:** Read-only**Protectable:** No**Default Value:** 00h**Units:** N/A

COMMAND	STATUS_TEMP (7Dh)							
Format	Bit Field							
Bit Position	7	6	5	4	3	2	1	0
Access	R	R	R	R	R	R	R	R
Function	See Following Table							
Default Value	0	0	0	0	0	0	0	0

BIT NUMBER	STATUS BIT NAME	MEANING
7	OT_FAULT	An over-temperature fault has occurred.
6	OT_WARNING	An over-temperature warning has occurred.
5	UT_WARNING	An under-temperature warning has occurred.
4	UT_FAULT	An under-temperature fault has occurred.
3:0	Not Used	Not used

STATUS_CML (7Eh)

Definition: Returns one byte of information with a summary of any communications, logic, and/or memory errors.

Paged or Global: Global

Data Length in Bytes: 1

Data Format: Bit Field

Type: Read Only

Protectable: No

Default Value: 00h

Units: N/A

COMMAND	STATUS_CML (7Eh)							
Format	Bit Field							
Bit Position	7	6	5	4	3	2	1	0
Access	R	R	R	R	R	R	R	R
Function	See Following Table							
Default Value	0	0	0	0	0	0	0	0

BIT NUMBER	MEANING
7	Invalid or unsupported PMBus command was received.
6	The PMBus command was sent with invalid or unsupported data.
5	A packet error was detected in the PMBus command.
4:2	Not used
1	A PMBus command tried to write to a read-only or protected command, or a communication fault other than the ones listed in this table has occurred.
0	Not used

STATUS_MFR_SPECIFIC (80h)

Definition: Returns one byte of information providing the status of the device's voltage monitoring and clock synchronization faults.

Paged or Global: Global

Data Length in Bytes: 1

Data Format: Bit Field

Type: Read Only

Protectable: No

Default Value: 00h

Units: N/A

COMMAND	STATUS_MFR_SPECIFIC (80h)							
Format	Bit Field							
Bit Position	7	6	5	4	3	2	1	0
Access	R	R	R	R	R	R	R	R
Function	See Following Table							
Default Value	0	0	0	0	0	0	0	0

BIT	FIELD NAME	MEANING
7	Not Used	Not used
6	DDC Warning	An error was detected on the DDC bus.
5	VMON UV Warning	The voltage on the VMON pin has dropped 10% below the level set by MFR_VMON_UV_FAULT.
4	VMON OV Warning	The voltage on the VMON pin has risen 10% above the level set by MFR_VMON_OV_FAULT.
3	External Switching Period Fault	Loss of external clock synchronization has occurred.
2	Not Used	Not used
1	VMON UV Fault	The voltage on the VMON pin has dropped below the level set by MFR_VMON_UV_FAULT.
0	VMON OV Fault	The voltage on the VMON pin has risen above the level set by MFR_VMON_OV_FAULT.

READ_VIN (88h)

Definition: Returns the input voltage reading.

Paged or Global: Global

Data Length in Bytes: 2

Data Format: Linear-11

Type: Read Only

Protectable: No

Default Value: N/A

Units: V

Equation: $READ_VIN = Y \times 2^N$

Range: N/A

COMMAND	READ_VIN (88h)															
Format	Linear-11															
Bit Position	15	14	13	12	11	10	9	8	7	6	5	4	3	2	1	0
Access	R	R	R	R	R	R	R	R	R	R	R	R	R	R	R	R
Function	Signed Exponent, N								Signed Mantissa, Y							
Default Value	N/A	N/A	N/A	N/A	N/A	N/A	N/A	N/A	N/A	N/A	N/A	N/A	N/A	N/A	N/A	N/A

READ_IIN (89h)**Definition:** Returns the input current reading.**Paged or Global:** Global**Data Length in Bytes:** 2**Data Format:** Linear-11**Type:** Read Only**Protectable:** No**Default Value:** N/A**Units:** A**Equation:** $READ_IIN = Y \times 2^N$ **Range:** N/A

COMMAND	READ_IIN (89h)															
Format	Linear-11															
Bit Position	15	14	13	12	11	10	9	8	7	6	5	4	3	2	1	0
Access	R	R	R	R	R	R	R	R	R	R	R	R	R	R	R	R
Function	Signed Exponent, N					Signed Mantissa, Y										
Default Value	N/A	N/A	N/A	N/A	N/A	N/A	N/A	N/A	N/A	N/A	N/A	N/A	N/A	N/A	N/A	N/A

READ_VOUT (8Bh)**Definition:** Returns the output voltage reading.**Paged or Global:** Paged**Data Length in Bytes:** 2**Data Format:** Linear-16 Unsigned**Type:** Read Only**Protectable:** No**Default Value:** N/A**Equation:** $READ_VOUT = READ_VOUT \times 2^{-13}$ **Units:** V

COMMAND	READ_VOUT (8Bh)															
Format	Linear-16 Unsigned															
Bit Position	15	14	13	12	11	10	9	8	7	6	5	4	3	2	1	0
Access	R	R	R	R	R	R	R	R	R	R	R	R	R	R	R	R
Default Value	N/A	N/A	N/A	N/A	N/A	N/A	N/A	N/A	N/A	N/A	N/A	N/A	N/A	N/A	N/A	N/A

READ_IOUT (8Ch)**Definition:** Returns the output current reading.**Paged or Global:** Paged**Data Length in Bytes:** 2**Data Format:** Linear-11**Type:** Read Only**Protectable:** No**Default Value:** N/A**Units:** A**Equation:** $READ_IOUT = Y \times 2^N$ **Range:** N/A

COMMAND	READ_IOUT (8Ch)															
Format	Linear-11															
Bit Position	15	14	13	12	11	10	9	8	7	6	5	4	3	2	1	0
Access	R	R	R	R	R	R	R	R	R	R	R	R	R	R	R	R
Function	Signed Exponent, N								Signed Mantissa, Y							
Default Value	N/A	N/A	N/A	N/A	N/A	N/A	N/A	N/A	N/A	N/A	N/A	N/A	N/A	N/A	N/A	N/A

READ_TEMPERATURE_1 (8Dh)**Definition:** Returns the temperature reading internal to the device.**Paged or Global:** Global**Data Length in Bytes:** 2**Data Format:** Linear-11**Type:** Read Only**Protectable:** No**Default Value:** N/A**Units:** °C**Equation:** $READ_TEMPERATURE_1 = Y \times 2^N$ **Range:** N/A

COMMAND	READ_TEMPERATURE_1 (8Dh)															
Format	Linear-11															
Bit Position	15	14	13	12	11	10	9	8	7	6	5	4	3	2	1	0
Access	R	R	R	R	R	R	R	R	R	R	R	R	R	R	R	R
Function	Signed Exponent, N								Signed Mantissa, Y							
Default Value	N/A	N/A	N/A	N/A	N/A	N/A	N/A	N/A	N/A	N/A	N/A	N/A	N/A	N/A	N/A	N/A

READ_TEMPERATURE_2 (8Eh)

Definition: Returns the temperature reading from the external temperature device connected to XTEMP.

Paged or Global: Paged

Data Length in Bytes: 2

Data Format: Linear-11

Type: Read Only

Protectable: No

Default Value: N/A

Units: °C

Equation: $READ_TEMPERATURE_2 = Y \times 2^N$

Range: N/A

COMMAND	READ_TEMPERATURE_2 (8Eh)															
Format	Linear-11															
Bit Position	15	14	13	12	11	10	9	8	7	6	5	4	3	2	1	0
Access	R	R	R	R	R	R	R	R	R	R	R	R	R	R	R	R
Function	Signed Exponent, N					Signed Mantissa, Y										
Default Value	N/A	N/A	N/A	N/A	N/A	N/A	N/A	N/A	N/A	N/A	N/A	N/A	N/A	N/A	N/A	N/A

READ_TEMPERATURE_3 (8Fh)

Definition: Returns the temperature reading from the VMON/TMON pin when the device is configured to read temperature on the VMON/TMON pin by setting bit 12 in the USER_GLOBAL_CONFIG command to 1. The voltage on the VMON/TMON pin is converted to °C by the equation $TEMPERATURE\ 3 = (VMON\ voltage - 0.6V)/0.008$. See MFR_VMON commands starting on [page 85](#) (F5h, F6h, F8h, F9h) for fault limits when reading temperature on the VMON/TMON pin. When using the Intersil ISL9922X smart power stage, a 2:1 voltage divider is needed between the TMON pin of the ISL9922X and the VMON/TMON pin of the ZL8802.

Paged or Global: Global

Data Length in Bytes: 2

Data Format: Linear-11

Type: Read Only

Protectable: No

Default Value: N/A

Units: °C

Equation: $READ_TEMPERATURE_3 = Y \times 2^N$

Range: N/A

COMMAND	READ_TEMPERATURE_3 (8Fh)															
Format	Linear-11															
Bit Position	15	14	13	12	11	10	9	8	7	6	5	4	3	2	1	0
Access	R	R	R	R	R	R	R	R	R	R	R	R	R	R	R	R
Function	Signed Exponent, N					Signed Mantissa, Y										
Default Value	N/A	N/A	N/A	N/A	N/A	N/A	N/A	N/A	N/A	N/A	N/A	N/A	N/A	N/A	N/A	N/A

READ_DUTY_CYCLE (94h)

Definition: Reports the actual duty cycle of the converter during the enable state.

Paged or Global: Paged

Data Length in Bytes: 2

Data Format: Linear-11

Type: Read Only

Protectable: No

Default Value: N/A

Units: %

Equation: $READ_DUTY_CYCLE = Y \times 2^N$

Range: 0 to 100%

COMMAND	READ_DUTY_CYCLE (94h)															
Format	Linear-11															
Bit Position	15	14	13	12	11	10	9	8	7	6	5	4	3	2	1	0
Access	R	R	R	R	R	R	R	R	R	R	R	R	R	R	R	R
Function	Signed Exponent, N					Signed Mantissa, Y										
Default Value	N/A	N/A	N/A	N/A	N/A	N/A	N/A	N/A	N/A	N/A	N/A	N/A	N/A	N/A	N/A	N/A

READ_FREQUENCY (95h)

Definition: Reports the actual switching frequency of the converter during the enable state.

Paged or Global: Global

Data Length in Bytes: 2

Data Format: Linear-11

Type: Read Only

Default Value: N/A

Units: kHz

Equation: $READ_FREQUENCY = Y \times 2^N$

Range: N/A

COMMAND	READ_FREQUENCY (95h)															
Format	Linear-11															
Bit Position	15	14	13	12	11	10	9	8	7	6	5	4	3	2	1	0
Access	R	R	R	R	R	R	R	R	R	R	R	R	R	R	R	R
Function	Signed Exponent, N					Signed Mantissa, Y										
Default Value	N/A	N/A	N/A	N/A	N/A	N/A	N/A	N/A	N/A	N/A	N/A	N/A	N/A	N/A	N/A	N/A

PMBUS_REVISION (98h)

Definition: Returns the revision of the PMBus specification to which the device is compliant.

Data Length in Bytes: 1

Data Format: Bit Field

Type: Read Only

Protectable: N/A

Default Value: 22h (Part 1 Revision 1.2, Part 2 Revision 1.2)

Units: N/A

COMMAND	PMBUS_REVISION (98h)							
Format	Bit Field							
Bit Position	7	6	5	4	3	2	1	0
Access	R	R	R	R	R	R	R	R
Function	See Following Table							
Default Value	0	0	1	0	0	0	1	0

BITS 7:4	PART 1 REVISION	BITS 3:0	PART 2 REVISION
0000	1.0	0000	1.0
0001	1.1	0001	1.1
0010	1.2	0010	1.2

MFR_ID (99h)

Definition: Sets a user defined identification string not to exceed 32bytes. The sum total of characters in MFR_ID, MFR_MODEL, MFR_REVISION, MFR_LOCATION, MFR_DATE, MFR_SERIAL, and USER_DATA_00 plus one byte per command cannot exceed 128bytes. This limitation includes multiple writes of this command before a STORE command. To clear multiple writes, perform a RESTORE, write this command then perform a STORE/RESTORE.

Paged or Global: Global

Data Length in Bytes: User defined

Data Format: ASCII, ISO/IEC 8859-1

Type: Block R/W

Protectable: Yes

Default Value: Null

Units: N/A

MFR_MODEL (9Ah)

Definition: Sets a user defined model string not to exceed 32bytes. The sum total of characters in MFR_ID, MFR_MODEL, MFR_REVISION, MFR_LOCATION, MFR_DATE, MFR_SERIAL, and USER_DATA_00 plus one byte per command cannot exceed 128bytes. This limitation includes multiple writes of this command before a STORE command. To clear multiple writes, perform a RESTORE, write this command then perform a STORE/RESTORE.

Paged or Global: Global

Data Length in Bytes: User defined

Data Format: ASCII, ISO/IEC 8859-1

Type: Block R/W

Protectable: Yes

Default Value: Null

Units: N/A

MFR_REVISION (9Bh)

Definition: Sets a user defined revision string not to exceed 32bytes. The sum total of characters in MFR_ID, MFR_MODEL, MFR_REVISION, MFR_LOCATION, MFR_DATE, MFR_SERIAL, and USER_DATA_00 plus one byte per command cannot exceed 128bytes. This limitation includes multiple writes of this command before a STORE command. To clear multiple writes, perform a RESTORE, write this command then perform a STORE/RESTORE.

Paged or Global: Global

Data Length in Bytes: User defined

Data Format: ASCII. ISO/IEC 8859-1

Type: Block R/W

Protectable: Yes

Default Value: Null

Units: N/A

MFR_LOCATION (9Ch)

Definition: Sets a user defined location identifier string not to exceed 32bytes. The sum total of characters in MFR_ID, MFR_MODEL, MFR_REVISION, MFR_LOCATION, MFR_DATE, MFR_SERIAL, and USER_DATA_00 plus one byte per command cannot exceed 128bytes. This limitation includes multiple writes of this command before a STORE command. To clear multiple writes, perform a RESTORE, write this command then perform a STORE/RESTORE.

Paged or Global: Global

Data Length in Bytes: User defined

Data Format: ASCII. ISO/IEC 8859-1

Type: Block R/W

Protectable: Yes

Default Value: Null

Units: N/A

MFR_DATE (9Dh)

Definition: Sets a user defined date string not to exceed 32bytes. The sum total of characters in MFR_ID, MFR_MODEL, MFR_REVISION, MFR_LOCATION, MFR_DATE, MFR_SERIAL, and USER_DATA_00 plus one byte per command cannot exceed 128bytes. This limitation includes multiple writes of this command before a STORE command. To clear multiple writes, perform a RESTORE, write this command then perform a STORE/RESTORE.

Paged or Global: Global

Data Length in Bytes: User defined

Data Format: ASCII. ISO/IEC 8859-1

Type: Block R/W

Protectable: Yes

Default Value: Null

Units: N/A

MFR_SERIAL (9Eh)

Definition: Sets a user defined serialized identifier string not to exceed 32bytes. The sum total of characters in MFR_ID, MFR_MODEL, MFR_REVISION, MFR_LOCATION, MFR_DATE, MFR_SERIAL, and USER_DATA_00 plus one byte per command cannot exceed 128bytes. This limitation includes multiple writes of this command before a STORE command. To clear multiple writes, perform a RESTORE, write this command then perform a STORE/RESTORE.

Paged or Global: Global

Data Length in Bytes: User defined

Data Format: ASCII. ISO/IEC 8859-1

Type: Block R/W

Protectable: Yes

Default Value: Null

Units: N/A

IC_DEVICE_ID (ADh)**Definition:** Reports device identification information.**Data Length in Bytes:** 4**Data Format:** CUS**Type:** Block Read**Protectable:** No**Default Value:** 49A02D00h (ZL8802)**Units:** N/A

COMMAND	IC_DEVICE_ID (ADh)			
Format	Block Read			
Byte Position	3	2	1	0
Function	MFR code	ID High Byte	ID Low Byte	Reserved
Default Value	49h	A0h	2Ah	00h

IC_DEVICE_REV (AEh)**Definition:** Reports device revision information.**Data Length in Bytes:** 4**Data Format:** CUS**Type:** Block Read**Protectable:** No**Default Value:** 01000000h (initial release)**Units:** N/A

COMMAND	IC_DEVICE_REV (AEh)			
Format	Block Read			
Byte Position	3	2	1	0
Function	Firmware Major	Firmware Minor	Factory Configuration	Reserved
Default Value	01h	00h	00h	00h

USER_DATA_00 (B0h)

Definition: Sets a user defined data string not to exceed 32bytes. The sum total of characters in MFR_ID, MFR_MODEL, MFR_REVISION, MFR_LOCATION, MFR_DATE, MFR_SERIAL, and USER_DATA_00 plus one byte per command cannot exceed 128bytes. This limitation includes multiple writes of this command before a STORE command. To clear multiple writes, perform a RESTORE, write this command then perform a STORE/RESTORE.

Paged or Global: Global**Data Length in Bytes:** User defined**Data Format:** ASCII. ISO/IEC 8859-1**Type:** Block R/W**Protectable:** Yes**Default Value:** Null**Units:** N/A

MIN_VOUT_REG (CEh)

Definition: Sets the minimum output voltage in millivolts (mV) that the device will attempt to regulate to during start-up and shutdown ramps.

Paged or Global: Paged

Data Length in Bytes: 2

Data Format: Linear-11

Type: R/W

Protectable: Yes

Default Value: 0000h (0mV)

Units: A

Equation: $MIN_VOUT_REG = Y \times 2^N$

COMMAND	MIN_VOUT_REG (CEh)															
Format	Linear-11															
Bit Position	15	14	13	12	11	10	9	8	7	6	5	4	3	2	1	0
Access	R/W	R/W	R/W	R/W	R/W	R/W	R/W	R/W	R/W	R/W	R/W	R/W	R/W	R/W	R/W	R/W
Function	Signed Exponent, N					Signed Mantissa, Y										
Default Value	1	1	1	1	0	0	1	0	0	1	0	1	1	0	0	0

ISENSE_CONFIG (D0h)

Definition: Configures current sense circuitry.

Paged or Global: Paged

Data Length in Bytes: 2

Data Format: Bit Field

Type: R/W word

Protectable: Yes

Default Value: 620Eh (384ns blanking, SPS sensing, high range)

Units: N/A

Range: N/A

COMMAND	ISENSE_CONFIG (D0h)															
Format	Bit Field															
Bit Position	15	14	13	12	11	10	9	8	7	6	5	4	3	2	1	0
Access	R/W	R/W	R/W	R/W	R/W	R/W	R/W	R/W	R/W	R/W	R/W	R/W	R/W	R/W	R/W	R/W
Function	See Following Table															
Default Value	0	1	1	0	0	0	1	0	0	0	0	0	1	1	1	0

BIT	FIELD NAME	VALUE	SETTING	DESCRIPTION
15:11	Current Sense Blanking Time	00000	0	Sets the blanking time current sense blanking time in increments of 32ns
		00001	32	
		00010	64	
		00011	96	
		00100	128	
		00101	160	
		00110	192	
		00111	224	
		01000	256	
		01001	288	
		01010	320	
		01011	352	
		01100	384	
		01101	416	
		01110	448	
		01111	480	
		10000	512	
		10001	544	
		10010	576	
		10011	608	
10100	640			
10101	672			
10110	704			
10111	736			
11000	768			
11001	800			
11010	832			
10:8	Current Sense Fault Count	000	1	Sets the number of consecutive overcurrent (OC) or undercurrent (UC) events required for a fault. An event can occur once during each switching cycle. For example, if 5 is selected, an OC or UC event must occur for 5 consecutive switching cycles, resulting in a delay of at least 5 switching periods.
		001	3	
		010	5	
		011	7	
		100	9	
		101	11	
		110	13	
		111	15	
7:4	Not Used	0000	Not Used	Not used
3:2	Current Sense Control	00	Not Used	Selection of current sensing method (SPS IMON)
		01	DCR (Down Slope)	
		10	DCR (Up Slope)	
		11	SPS	
1:0	Current Sense Range	00	Low Range	Low range ±25mV, medium range ±35mV, high range ±50mV
		01	Medium Range	
		10	High Range	
		11	Not Used	

USER_CONFIG (D1h)

Definition: Configures several user-level features. This command should be saved immediately after being written to the desired user or default store. This is recommended when written as an individual command or as part of a series of commands in a configuration file or script.

Paged or Global: Paged

Data Length in Bytes: 2

Data Format: Bit Field

Type: R/W

Protectable: Yes

Default Value: Set by CFG pin-strap setting

Units: N/A

COMMAND	USER_CONFIG (D1h)															
Format	Bit Field															
Bit Position	15	14	13	12	11	10	9	8	7	6	5	4	3	2	1	0
Access	R/W	R/W	R/W	R/W	R/W	R/W	R/W	R/W	R/W	R/W	R/W	R/W	R/W	R/W	R/W	R/W
Function	See Following Table															
Default Value	CFG Pin-strap Setting															

BIT	FIELD NAME	VALUE	SETTING	DESCRIPTION
15:11	Minimum Duty Cycle	00000	0-31d	Sets the minimum duty-cycle to $2X(VALUE+1)/512$. Must be enabled with Bit 7
10	Not Used	1	Not Used	Not used
9:8	Not Used	00	Not Used	Not used
7	Minimum Duty Cycle Control	0	Disable	Control for minimum duty cycle
		1	Enable	
6	Not Used	0	Not Used	Not used
5	VSET Select	0	VSET0	0 = Uses only VSET0 to set the pin-strapped output voltage
		1	VSET1	1 = Uses only VSET1 to set the pin-strapped output voltage
4	Not Used	0	Not Used	Not used
3	PWML disabled state	0	Low when disabled	PWML is low (off) when device is disabled (Bit 3 set to 0), or high (on) when device is disabled (Bit 3 set to 1)
		1	High when disabled	
2	Power-good Configuration	0	Open-Drain	0 = PG is open-drain output
		1	Push-Pull	1 = PG is push-pull output
1	XTEMP Enable	0	Disable	Enable external temperature sensor
		1	Enable	
0	XTEMP Fault Select	0	Disable	Selects external temperature sensor to determine temperature faults
		1	Enable	

IIN_CAL_GAIN (D2h)

Definition: Sets the effective impedance across the current sense circuit for use in calculating input current at +25°C.

Paged or Global: Global

Data Length In Bytes: 2

Data Format: Linear-11

Type: R/W

Protectable: Yes

Default Value: C200h (2mΩ)

Units: mΩ

Equation: $IIN_CAL_GAIN = Y \times 2^N$

COMMAND	IIN_CAL_GAIN (D2h)															
Format	Linear-11															
Bit Position	15	14	13	12	11	10	9	8	7	6	5	4	3	2	1	0
Access	R/W	R/W	R/W	R/W	R/W	R/W	R/W	R/W	R/W	R/W	R/W	R/W	R/W	R/W	R/W	R/W
Function	Signed Exponent, N						Signed Mantissa, Y									
Default Value	1	1	0	0	0	0	1	0	0	0	0	0	0	0	0	0

DDC_CONFIG (D3h)

Definition: Configures DDC addressing and current sharing for up to 8 phases. To operate as a 2-phase controller, set both phases to the same rail ID, set phases in rail to 2, then set each phase ID **sequentially** as 0 and 1. To operate as a 4-phase controller, set all phases to the same rail ID, set phases in rail to 4, then set each phase ID alternately, for example, the first ZL8802 will be set to 0 and 2, the second ZL8802 will be set to 1 and 3. The ZL8802 will automatically equally offset the phases in the rail. Phase spreading is done automatically as part of the DDC_CONFIG command. **When using CFG pin-strap settings, the DDC_CONFIG command is set automatically.**

NOTE: The output MUST be connected to VSENOP and VSENON when operating as a 2-phase controller.

Paged or Global: Paged

Data Length in Bytes: 2

Data Format: Bit Field

Type: R/W

Protectable: Yes

Default Value: PMBus address pin-strap dependent.

Units: N/A

COMMAND	DDC_CONFIG (D3h)															
Format	Bit Field															
Bit Position	15	14	13	12	11	10	9	8	7	6	5	4	3	2	1	0
Access	R/W	R/W	R/W	R/W	R/W	R/W	R/W	R/W	R/W	R/W	R/W	R/W	R/W	R/W	R/W	R/W
Function	See Following Table															
Default Value	0	0	0	Lower 5 bits of device address				0	0	0	0	0	0	0	0	0

BIT	FIELD NAME	VALUE	SETTING	DESCRIPTION
15:13	Phase ID	0 to 7	0	Sets the output's phase position within the rail
12:8	Rail ID	0 to 31d	0	Identifies the device as part of a current sharing rail (shared output)
7:3	Not Used	00	00	Not used
2:0	Phases In Rail	0 to 7	0	Identifies the number of phases on the same rail (+1)

POWER_GOOD_DELAY (D4h)

Definition: Sets the delay applied between the output exceeding the PG threshold (POWER_GOOD_ON) and asserting the PG pin. The delay time can range from 0ms up to 500ms, in steps of 125ns. A 1ms minimum configured value is recommended to apply proper debounce to this signal.

Paged or Global: Paged

Data Length in Bytes: 2

Data Format: Linear-11

Type: R/W

Protectable: Yes

Default Value: BA00h, 1ms

Units: ms

Equation: POWER_GOOD_DELAY = $Y \times 2^N$

Range: 0 to 500ms

COMMAND	POWER_GOOD_DELAY (D4h)															
Format	Linear-11															
Bit Position	15	14	13	12	11	10	9	8	7	6	5	4	3	2	1	0
Access	R/W	R/W	R/W	R/W	R/W	R/W	R/W	R/W	R/W	R/W	R/W	R/W	R/W	R/W	R/W	R/W
Function	Signed Exponent, N						Signed Mantissa, Y									
Default Value	1	0	1	1	1	0	1	0	0	0	0	0	0	0	0	0

MULTI_PHASE_RAMP_GAIN (D5h)

Definition: Indirectly determines the output voltage rise time during the turn-on ramp. Typical gain values range from 1 to 10. Lower gain values produce longer ramp times.

MULTI_PHASE_RAMP_GAIN mode is automatically selected when the ZL8802 is configured to operate in a 4-phase current sharing group. When in MULTI_PHASE_RAMP_GAIN mode, the turn-on ramp up is done with the high bandwidth ASCR control circuitry disabled, resulting in a lower loop bandwidth during start-up ramps. After POWER_GOOD has been asserted, ASCR circuitry is enabled and the ZL8802 operates normally. When MULTI_PHASE_RAMP_GAIN mode is enabled, soft-off ramps are not allowed (TOFF_FALL is ignored). When the ZL8802 is commanded to shutdown, the PWMH0/1 output is tri-stated, turning both the high-side and low-side MOSFETs off, and the PWML0/1 pin is pulled low (DrMOS disabled). Large load current transitions during multiphase ramp-ups will cause output voltage discontinuities.

When the phase count is 2; that is, when the ZL8802 is operating standalone, ASCR is enabled at all times and all commands associated with turn-on and turn-off (TON_RISE, TOFF_FALL, Soft-Off) operate normally.

Rise time can be calculated using [Equation 8](#):

$$\text{RiseTime} = \text{VOUT_COMMAND} / \{ 14 \cdot \text{Input Voltage} \cdot \text{FREQUENCY_SWITCH (in MHz)} \cdot \text{MULTI_PHASE_RAMP_GAIN} \} \quad (\text{EQ. 8})$$

Paged or Global: Global

Data Length in Bytes: 1

Data Format: Custom

Type: R/W

Protectable: Yes

Default Value: 03h

Units: N/A

COMMAND	MULTI_PHASE_RAMP_GAIN (D5h)							
Format	1 Byte Binary							
Bit Position	7	6	5	4	3	2	1	0
Access	R/W	R/W	R/W	R/W	R/W	R/W	R/W	R/W
Default Value	0	0	0	0	0	0	1	1

BIT	FIELD NAME	VALUE	DESCRIPTION
7:0	Gain	00-FF	Start-up ramp gain

INDUCTOR (D6h)

Definition: Informs the device of the circuit's inductor value. This is used in adaptive algorithm calculations relating to the inductor ripple current.

Paged or Global: Paged

Data Length in Bytes: 2

Data Format: Linear-11

Type: R/W

Protectable: Yes

Default Value: B133h (0.3μH)

Units: μH

Equation: $INDUCTOR = Y \times 2^N$

Range: 0 to 100μH

COMMAND	INDUCTOR (D6h)															
Format	Linear-11															
Bit Position	15	14	13	12	11	10	9	8	7	6	5	4	3	2	1	0
Access	R/W	R/W	R/W	R/W	R/W	R/W	R/W	R/W	R/W	R/W	R/W	R/W	R/W	R/W	R/W	R/W
Function	Signed Exponent, N								Signed Mantissa, Y							
Default Value	1	0	1	1	0	0	0	1	0	0	1	1	0	0	1	1

SNAPSHOT_FAULT_MASK (D7h)

Definition: Prevents faults from causing a SNAPSHOT event (and store) from occurring.

Data Length in Bytes: 2

Data Format: BIT

Type: R/W

Protectable: Yes

Default Value: 0000h

Units: NA

Range: NA

COMMAND	SNAPSHOT_FAULT_MASK (D7h)															
Format	Bit Field															
Bit Position	15	14	13	12	11	10	9	8	7	6	5	4	3	2	1	0
Access	R	R	R	R	R	R	R	R	R	R	R	R	R	R	R	R
Function	See Following Table															
Default Value	0	0	0	0	0	0	0	0	0	0	0	0	0	0	0	0

BIT NUMBER	STATUS BIT NAME	MEANING
15:14	Not Used	Not used
13	Group	Ignore Fault Spreading faults
12	Phase	Ignore Other Phase faults
11	CPU	Ignore CPU faults
10	CRC	Ignore CRC Memory faults
9	Not Used	Not used
8	Not Used	Not used
7	IOUT_UC_FAULT	Ignore output undercurrent faults
6	IOUT_OC_FAULT	Ignore output overcurrent faults
5	VIN_UV_FAULT	Ignore input undervoltage faults
4	VIN_OV_FAULT	Ignore Input undervoltage faults
3	UT_FAULT	Ignore under-temperature faults
2	OT_FAULT	Ignore over-temperature faults
1	VOUT_UV_FAULT	Ignore output undervoltage faults
0	VOUT_OV_FAULT	Ignore output overvoltage faults

OVUV_CONFIG (D8h)**Definition:** Configures the output voltage OV and UV fault detection feature**Paged or Global:** Paged**Data Length in Bytes:** 1**Data Format:** Bit Field**Type:** R/W**Protectable:** Yes**Default Value:** 00h**Units:** N/A

COMMAND	OVUV_CONFIG (D8h)							
Format	Bit Field							
Bit Position	7	6	5	4	3	2	1	0
Access	R/W	R/W	R/W	R/W	R/W	R/W	R/W	R/W
Function	See Following Table							
Default Value	0	0	0	0	0	0	0	0

BITS	PURPOSE	VALUE	DESCRIPTION
7	Controls how an OV fault response shutdown sets the output driver state	0	An OV fault does not enable low-side power device
		1	An OV fault enables the low-side power device
6:4	Not Used	0	Not used
3:0	Defines the number of consecutive limit violations required to declare an OV or UV fault	N	N+1 consecutive OV or UV violations initiate a fault response

XTEMP_SCALE (D9h)**Definition:** Sets a scalar value that is used for calibrating the external temperature. The constant is applied in the equation below to produce the read value of XTEMP through the PMBus command READ_TEMPERATURE_2.**Paged or Global:** Paged**Data Length in Bytes:** 2**Data Format:** Linear-11**Type:** R/W**Protectable:** Yes**Default Value:** BA00h (1.0)**Units:** 1/°C

Equation: $READ_TEMPERATURE_2 = \left(ExternalTemperature \cdot \frac{1}{XTEMP_SCALE} \right) + XTEMP_OFFSET$

Range: 0.1 to 10

COMMAND	XTEMP_SCALE (D9h)															
Format	Linear-11															
Bit Position	15	14	13	12	11	10	9	8	7	6	5	4	3	2	1	0
Access	R/W	R/W	R/W	R/W	R/W	R/W	R/W	R/W	R/W	R/W	R/W	R/W	R/W	R/W	R/W	R/W
Function	Signed Exponent, N						Signed Mantissa, Y									
Default Value	1	0	1	1	1	0	1	0	0	0	0	0	0	0	0	0

XTEMP_OFFSET (DAh)

Definition: Sets an offset value that is used for calibrating the external temperature. The constant is applied in the equation below to produce the read value of XTEMP through the PMBus command READ_TEMPERATURE_2.

Paged or Global: Paged

Data Length in Bytes: 2

Data Format: Linear-11

Type: R/W

Protectable: Yes

Default Value: 0000h (0)

Units: °C

Equation: $READ_TEMPERATURE_2 = \left(ExternalTemperature \cdot \frac{1}{XTEMP_SCALE} \right) + XTEMP_OFFSET$

Range: -100°C to +100°C

COMMAND	XTEMP_OFFSET (DAh)															
Format	Linear-11															
Bit Position	15	14	13	12	11	10	9	8	7	6	5	4	3	2	1	0
Access	R/W	R/W	R/W	R/W	R/W	R/W	R/W	R/W	R/W	R/W	R/W	R/W	R/W	R/W	R/W	R/W
Function	Signed Exponent, N					Signed Mantissa, Y										
Default Value	0	0	0	0	0	0	0	0	0	0	0	0	0	0	0	0

MFR_SMBALERT_MASK (DBh)

Definition: Used to prevent faults from activating the SALRT pin. The bits in each byte correspond to a specific fault type as defined in the STATUS command.

Data Length in Bytes: 7

Data Format: Bit Field

Type: R/W

Protectable: Yes

Default Value: 00 00 00 00 00 00 00h (No faults masked)

Units: N/A

COMMAND	MFR_SMBALERT_MASK (DBh)							
Format	Bit Field							
Access	R/W	R/W	R/W	R/W	R/W	R/W	R/W	R/W
Function	See following table							
Bit Position	55	54	53	52	51	50	49	48
Default Value Byte 6	0	0	0	0	0	0	0	0
Bit Position	47	46	45	44	43	42	41	40
Default Value Byte 5	0	0	0	0	0	0	0	0
Bit Position	39	38	37	36	35	34	33	32
Default Value Byte 4	0	0	0	0	0	0	0	0
Bit Position	31	30	29	28	27	26	25	24
Default Value Byte 3	0	0	0	0	0	0	0	0
Bit Position	23	22	21	20	19	18	17	16
Default Value Byte 2	0	0	0	0	0	0	0	0
Bit Position	15	14	13	12	11	10	9	8
Default Value Byte 1	0	0	0	0	0	0	0	0
Bit Position	7	6	5	4	3	2	1	0
Default Value Byte 0	0	0	0	0	0	0	0	0

BYTE	STATUS BYTE NAME	MEANING
6	STATUS_MFR_SPECIFIC	Mask manufacturer specific faults as identified in the STATUS_MFR_SPECIFIC byte.
5	STATUS_OTHER	Not used
4	STATUS_CML	Mask communications, memory, or logic specific faults as identified in the STATUS_CML byte.
3	STATUS_TEMPERATURE	Mask temperature specific faults as identified in the STATUS_TEMPERATURE byte.
2	STATUS_INPUT	Mask input specific faults as identified in the STATUS_INPUT byte.
1	STATUS_IOUT	Mask output current specific faults as identified in the STATUS_IOUT byte.
0	STATUS_VOUT	Mask output voltage specific faults as identified in the STATUS_VOUT byte.

TEMPCO_CONFIG (DCh)

Definition: Configures the correction factor and temperature measurement source when performing temperature coefficient correction for current sense. TEMPCO_CONFIG values are applied as negative correction to a positive temperature coefficient. TEMPCO_CONFIG should be set to 3900ppm (27h) when using inductor DCR current sensing to compensate for the variation in inductor resistance due to the temperature coefficient of copper. When using the ISL9922X Smart Power Stage, TEMPCO_CONFIG should be set to 0ppm (00h) because the IMON signal from the ISL9922X is internally compensated for temperature.

Paged or Global: Paged

Data Length in Bytes: 1

Data Format: Bit Field

Type: R/W

Protectable: Yes

Default Value: 00h (0ppm/°C, copper)

Equation: To determine the hex value of the Tempco Correction factor (TC) for current scale of a power stage current sensing, first determine the temperature coefficient of resistance for the sensing element, α . This is found with [Equation 9](#):

$$\alpha = \frac{R_{REF} - R}{R_{REF}(T_{REF} - T)} \quad (\text{EQ. 9})$$

Where:

R = Sensing element resistance at temperature "T"

R_{REF} = Sensing element resistance at reference temperature T_{REF}

α = Temperature coefficient of resistance for the sensing element material

T = Temperature measured by temperature sensor, in degrees Celsius

T_{REF} = Reference temperature that α is specified at for the sensing element material

After α is determined, convert the value in units of 100ppm/°C. This value is then converted to a hex value with [Equation 10](#):

$$TC = \frac{\alpha \times 10^6}{100} \quad (\text{EQ. 10})$$

Range: 0 to 12700ppm/°C

COMMAND	TEMPCO_CONFIG (DCh)							
Format	Bit Field							
Bit Position	7	6	5	4	3	2	1	0
Access	R/W	R/W	R/W	R/W	R/W	R/W	R/W	R/W
Function	See Following Table							
Default Value	0	0	0	0	0	0	0	0

BITS	PURPOSE	VALUE	DESCRIPTION
7	Selects the temp sensor source for tempco correction	0	Selects the internal temperature sensor.
		1	Selects the XTEMP pin for temperature measurements (2N3904 Junction). Note that XTEMP must be enabled in USER_CONFIG, Bit 1.
6:0	Sets the tempco correction in units of 100ppm/°C for IOUT_CAL_GAIN	TC	RSEN (DCR) = IOUT_CAL_GAIN x (1+TC x (T-25)) where RSEN = resistance of sense element.

PINSTRAP_READ_STATUS (DDh)

Definition: Reads back 7 bytes of 8-bit values that represent the pin-strap settings of each of the device's pin-strap pins. This value corresponds to a resistor value, a high, a low, or an open condition. The pin decode values correspond to pin-strap settings according to [Table 9](#):

TABLE 9. PIN DECODE VALUES

R (kΩ)	DECODE	R (kΩ)	DECODE
10	00	51.1	11
11	01	56.2	12
12.1	02	61.9	13
13.3	03	68.1	14
14.7	04	75	15
16.2	05	82.5	16
17.8	06	90.9	17
19.6	07	100	18
21.5	08	110	19
23.7	09	121	1A
26.1	0A	133	1B
28.7	0B	147	1C
31.6	0C	162	1D
34.8	0D	178	1E
38.3	0E	LOW	F1
42.2	0F	OPEN	F2
46.4	10	HIGH	F3
Unmeasured			F4

Paged or Global: Global

Data Length in Bytes: 7

Data Format: Bit Field

Type: Read Only

Protectable: Yes

Default Value: Pin-strap settings

Units: N/A

COMMAND	READ_PINSTRAP (DDh)															
Format	Bit Field															
Bit Position									55	54	53	52	51	50	49	48
Access									R	R	R	R	R	R	R	R
Function									ASCRCFG Pin Decode							
Default Value									ASCRCFG Pin-strap Setting							
Format	Bit Field															
Bit Position	47	46	45	44	43	42	41	40	39	38	37	36	35	34	33	32
Access	R	R	R	R	R	R	R	R	R	R	R	R	R	R	R	R
Function	CFG Pin Decode								SYNC Pin Decode							
Default Value	CFG Pin-strap Setting								SYNC Pin-strap Setting							
Format	Bit Field															

COMMAND	READ_PINSTRAP (DDh) (Continued)															
Bit Position	31	30	29	28	27	26	25	24	23	22	21	20	19	18	17	16
Access	R	R	R	R	R	R	R	R	R	R	R	R	R	R	R	R
Function	UVLO Pin Decode								VSET0 Pin Decode							
Default Value	UVLO Pin-strap Setting								VSET0 Pin-strap Setting							
Format	Bit Field															
Bit Position	15	14	13	12	11	10	9	8	7	6	5	4	3	2	1	0
Access	R	R	R	R	R	R	R	R	R	R	R	R	R	R	R	R
Function	VSET1 Pin Decode								Reserved							
Default Value	VSET1 Pin-strap Setting								N/A							

BITS	PURPOSE	VALUE	DESCRIPTION
55:48	ASCRCFG Pin Decode	00-F4h	Decode value of ASCRCFG pin-strap setting.
47:40	CFG Pin Decode	00-F4h	Decode value of CFG pin-strap setting.
39:32	SYNC Pin Decode	00-F4h	Decode value of SYNC pin-strap setting.
31:24	UVLO Pin Decode	00-F4h	Decode value of UVLO pin-strap setting.
23:16	VSET0 Pin Decode	00-F4h	Decode value of VSET0 pin-strap setting.
15:8	VSET1 Pin Decode	00-F4h	Decode value of VSET1 pin-strap setting.
7:0	Not Used	FF	Not used

ASCR_CONFIG (DFh)

Definition: Allows user configuration of ASCR settings. ASCR gain and residual value are automatically set by the ZL8802 based on input voltage and output voltage. ASCR gain is analogous to bandwidth, ASCR residual is analogous to damping. To improve load transient response performance, increase ASCR gain. To lower transient response overshoot, increase ASCR residual. Increasing ASCR gain can result in increased PWM jitter and should be evaluated in the application circuit. Excessive ASCR gain can lead to excessive output voltage ripple. Increasing ASCR residual to improve transient response damping can result in slower recovery times, but will not affect the peak output voltage deviation. Typical ASCR gain settings range from 100 to 1000, and ASCR residual settings range from 10 to 90.

Paged or Global: Paged

Data Length in Bytes: 4

Data Format: Bit Field and nonsigned binary

Type: R/W

Protectable: Yes

Default Value: ASCRCFG pin-strap setting

Units: N/A

COMMAND	ASCR_CONFIG (DFh)															
Format	Bit Field/Linear-8 Unsigned															
Bit Position	31	30	29	28	27	26	25	24	23	22	21	20	19	18	17	16
Access	R/W	R/W	R/W	R/W	R/W	R/W	R/W	R/W	R/W	R/W	R/W	R/W	R/W	R/W	R/W	R/W
Function	See Following Table															
Default Value	0	0	0	0	0	0	0	1	ASCRCFG Pin-strap Setting (residual)							
Format	Linear-16 Unsigned															
Bit Position	15	14	13	12	11	10	9	8	7	6	5	4	3	2	1	0
Access	R/W	R/W	R/W	R/W	R/W	R/W	R/W	R/W	R/W	R/W	R/W	R/W	R/W	R/W	R/W	R/W
Function	See Following Table															
Default Value	ASCRCFG Pin-strap Setting (gain)															

BITS	PURPOSE	VALUE	DESCRIPTION
31:25	Not Used	0000000h	Not used
24	ASCR Enable	1	Enable
		0	Disable
23:16	ASCR Residual Setting	0 - 7Fh	ASCR residual
15:0	ASCR Gain Setting	0-FFh	ASCR gain

SEQUENCE (E0h)

Definition: Identifies the Rail DDC ID of the prequel and sequel rails when performing multirail sequencing. The device will enable its output when its EN or OPERATION enable state, as defined by ON_OFF_CONFIG, is set and the prequel device has issued a Power-Good event on the DDC bus as a result of the prequel's Power-good (PG) signal going high. The device will disable its output (using the programmed delay values) when the sequel device has issued a power-down event on the DDC bus at the completion of its ramp-down (its output voltage is 0V).

The data field is a two-byte value. The most-significant byte contains the 5-bit Rail DDC ID of the prequel device. The least-significant byte contains the 5-bit Rail DDC ID of the sequel device. The most significant bit of each byte contains the enable of the prequel or sequel mode. This command overrides the corresponding sequence configuration set by the CONFIG pin settings.

Paged or Global: Paged

Data Length in Bytes: 2

Data Format: Bit Field

Type: R/W

Protectable: Yes

Default Value: 00h (prequel and sequel disabled)

Units: N/A

COMMAND	SEQUENCE (E0h)															
Format	Bit Field															
Bit Position	15	14	13	12	11	10	9	8	7	6	5	4	3	2	1	0
Access	R/W	R/W	R/W	R/W	R/W	R/W	R/W	R/W	R/W	R/W	R/W	R/W	R/W	R/W	R/W	R/W
Function	See Following Table															
Default Value	0	0	0	0	0	0	0	0	0	0	0	0	0	0	0	0

BIT	FIELD NAME	VALUE	SETTING	DESCRIPTION
15	Prequel Enable	0	Disable	Disable, no prequel preceding this rail.
		1	Enable	Enable, prequel to this rail is defined by Bits 12:8.
14:13	Not Used	0	Not Used	Not used
12:8	Prequel Rail DDC ID	0-31d	DDC ID	Set to the DDC ID of the prequel rail.
7	Sequel Enable	0	Disable	Disable, no sequel following this rail.
		1	Enable	Enable, sequel to this rail is defined by Bits 4:0.
6:5	Not Used	0	Not Used	Not used
4:0	Sequel Rail DDC ID	0-31d	DDC ID	Set to the DDC ID of the sequel rail.

TRACK_CONFIG (E1h)

Definition: Configures the voltage tracking modes of the device. Single device (Channel 0, Channel 1 or 2-phase) tracking is supported. Tracking as part of a 4-, 6- or 8-phase current sharing group is not supported. When tracking, the TOFF_DELAY in the tracking device must be greater than TOFF_DELAY + TOFF_FALL in the device being tracked. When configured to track, VOUT_COMMAND must be set to the desired steady state output voltage.

Data Length in Bytes: 1

Data Format: Bit Field

Type: R/W

Protectable: Yes

Default Value: 00h

Units: N/A

COMMAND	TRACK_CONFIG (E1h)							
Format	Bit Field							
Bit Position	7	6	5	4	3	2	1	0
Access	R/W	R/W	R/W	R/W	R/W	R/W	R/W	R/W
Function	See Following Table							
Default Value	0	0	0	0	0	0	0	0

BIT	FIELD NAME	VALUE	SETTING	DESCRIPTION
7	Voltage Tracking Control	0	Disable	Tracking is disabled.
		1	Enable	Tracking is enabled.
6:3	Not Used	0000	Not Used	Not used
2	Tracking Ratio Control	0	100%	Output Tracks at 100% ratio of VTRK input.
		1	50%	Output Tracks at 50% ratio of VTRK input.
1	Tracking Upper Limit	0	Target Voltage	Output Voltage is Limited by Target Voltage.
		1	VTRK Voltage	Output Voltage is Limited by VTRK Voltage.
0	Not Used	0	Not Used	Not used

DDC_GROUP (E2h)

Definition: Rails (output voltages) are assigned Group numbers to share specified behaviors. The DDC_GROUP command configures fault spreading group ID and enable, broadcast OPERATION group ID and enable, and broadcast VOUT_COMMAND group ID and enable. Note that DDC Groups are separate and unique from DDC Rail IDs (see [“DDC CONFIG \(D3h\)” on page 65](#)). Current sharing rails need to be in the same DDC Group to respond to broadcast VOUT_COMMAND and OPERATION commands. Power fail event responses (and phases) are automatically spread in Phase 0 and 1 when the ZL8802 is operating in 2-phase current sharing mode when it is configured using DDC_CONFIG, regardless of its setting in DDC_GROUP.

Paged or Global: Paged

Data Length in Bytes: 34

Data Format: Bit Field

Type: R/W

Protectable: Yes

Default Value: Set by CFG pin-strap setting

Units: N/A

COMMAND	DDC_GROUP (E2h)																
Format	Bit Field																
Bit Position	31	30	29	28	27	26	25	24	23	22	21	20	19	18	17	16	
Access	R/W	R/W	R/W	R/W	R/W	R/W	R/W	R/W	R/W	R/W	R/W	R/W	R/W	R/W	R/W	R/W	
Function	Not Used										EN>	VOUT_COMMAND Group ID					
Default Value	Set by CFG Pin-strap Setting																
Format	Bit Field																
Bit Position	15	14	13	12	11	10	9	8	7	6	5	4	3	2	1	0	
Access	R/W	R/W	R/W	R/W	R/W	R/W	R/W	R/W	R/W	R/W	R/W	R/W	R/W	R/W	R/W	R/W	
Function	Not Used		EN>	OPERATION Group ID					Not Used			EN>	Power Fail Group ID				
Default Value	Set by CFG Pin-strap Setting																

BITS	PURPOSE	VALUE	DESCRIPTION
31:22	Not Used	00	Not used
21	BROADCAST_VOUT_COMMAND response	1	Responds to broadcast VOUT_COMMAND with same Group ID.
		0	Ignores broadcast VOUT_COMMAND.
20:16	BROADCAST_VOUT_COMMAND group ID	0-31d	Group ID sent as data for broadcast VOUT_COMMAND events.
15:14	Not Used	00	Not used
13	BROADCAST_OPERATION response	1	Responds to broadcast OPERATION with same Group ID.
		0	Ignores broadcast OPERATION.
12:8	BROADCAST_OPERATION group ID	0-31d	Group ID sent as data for broadcast OPERATION events.
7:6	Not Used	00	Not used
5	POWER_FAIL response	1	Responds to POWER_FAIL events with same Group ID by shutting down immediately.
		0	Responds to POWER_FAIL events with same Group ID with sequenced shutdown.
4:0	POWER_FAIL group ID	0-31d	Group ID sent as data for broadcast POWER_FAIL events.

DEVICE_ID (E4h)

Definition: Returns the 16-byte (character) device identifier string. The format is: Part number, Major Revision, (period), Minor Revision, Engineering version letter

Paged or Global: Global

Data Length in Bytes: 16

Data Format: ASCII. ISO/IEC 8859-1

Type: Block Read

Protectable: Read Only

Default Value: ZL8802, current major revision, (period), current minor revision, current engineering version letter

Units: N/A

COMMAND	DEVICE_ID (E4h)															
Format	Characters (Bytes)															
Characters	15	14	13	12	11	10	9	8	7	6	5	4	3	2	1	0
Access	R	R	R	R	R	R	R	R	R	R	R	R	R	R	R	R
Function	Part Number										Maj. Rev.		.	Min. Rev		Engr.
Default Value	Z	L	8	8	0	0					*	*	*	*	*	*
* Current revision at time of manufacture																

MFR_IOUT_OC_FAULT_RESPONSE (E5h)

Definition: Configures the IOUT overcurrent fault response as defined by the table below. The command format is the same as the PMBus standard fault responses except that it sets the overcurrent status bit in STATUS_IOUT. The retry time is the time between restart attempts.

Paged or Global: Paged

Data Length in Bytes: 1

Data Format: Bit Field

Type: R/W

Protectable: Yes

Default Value: 80h (immediate shutdown, no retries)

Units: Retry time unit = 35ms

COMMAND	MFR_IOUT_OC_FAULT_RESPONSE (E5h)							
Format	Bit Field							
Bit Position	7	6	5	4	3	2	1	0
Access	R/W	R/W	R/W	R/W	R/W	R/W	R/W	R/W
Function	See Following Table							
Default Value	1	0	0	0	0	0	0	0

BIT	FIELD NAME	VALUE	DESCRIPTION
7:6	Response behavior, for all modes, the device: • Pulls SALRT low • Sets the related fault bit in the status registers. Fault bits are only cleared by the CLEAR_FAULTS command.	00	Not used
		01	Not used
		10	Disable without delay and retry according to the setting in bits 5:3.
		11	Output is disabled while the fault is present. Operation resumes and the output is enabled when the fault is no longer present.
5:3	Retry Setting	000	No retry. The output remains disabled until the fault is cleared.
		001-110	Not used
		111	Attempts to restart continuously, without checking if the fault is still present, until it is commanded OFF (by the CONTROL pin or OPERATION command or both), bias power is removed, or another fault condition causes the unit to shut down. The time between the start of each attempt to restart is set by the value in bits [2:0] multiplied by 35ms.
2:0	Retry Delay	000-111	Retry delay time = (Value +1)*35ms. Sets the time between retries in 35ms increments. Range is 35ms to 280ms.

MFR_IOUT_UC_FAULT_RESPONSE (E6h)

Definition: Configures the I_{OUT} undercurrent fault response as defined by the table below. The command format is the same as the PMBus standard fault responses except that it sets the undercurrent status bit in STATUS_IOUT. The retry time is the time between restart attempts.

Data Length in Bytes: 1

Paged or Global: Paged

Data Format: Bit Field

Type: R/W

Protectable: Yes

Default Value: 80h (Immediate shutdown, no retries)

Units: Retry time unit = 35ms

COMMAND	MFR_IOUT_UC_FAULT_RESPONSE (E6h)							
Format	Bit Field							
Bit Position	7	6	5	4	3	2	1	0
Access	R/W	R/W	R/W	R/W	R/W	R/W	R/W	R/W
Function	See Following Table							
Default Value	1	0	0	0	0	0	0	0

BIT	FIELD NAME	VALUE	DESCRIPTION
7:6	Response behavior, for all modes, the device: • Pulls SALRT low • Sets the related fault bit in the status registers. Fault bits are only cleared by the CLEAR_FAULTS command.	00	Not used
		01	Not used
		10	Disable without delay and retry according to the setting in bits 5:3.
		11	Output is disabled while the fault is present. Operation resumes and the output is enabled when the fault is no longer present.
5:3	Retry Setting	000	No retry. The output remains disabled until the fault is cleared.
		001-110	Not used
		111	Attempts to restart continuously, without checking if the fault is still present, until it is commanded OFF (by the CONTROL pin or OPERATION command or both), bias power is removed, or another fault condition causes the unit to shut down. The time between the start of each attempt to restart is set by the value in bits [2:0] multiplied by 35ms.
2:0	Retry Delay	000-111	Retry delay time = (Value +1) * 35ms. Sets the time between retries in 35ms increments. Range is 35ms to 280ms.

IOUT_AVG_OC_FAULT_LIMIT (E7h)

Definition: Sets the I_{OUT} average overcurrent fault threshold. For down-slope sensing, this corresponds to the average of all the current samples taken during the (1-D) time interval, excluding the current sense blanking time (which occurs at the beginning of the 1-D interval). For up-slope sensing, this corresponds to the average of all the current samples taken during the D time interval, excluding the current sense blanking time (which occurs at the beginning of the D interval). This feature shares the OC fault bit operation (in STATUS_IOUT) and OC fault response with IOUT_OC_FAULT_LIMIT.

Paged or Global: Paged

Data Length in Bytes: 2

Data Format: Linear-11

Type: R/W

Protectable: Yes

Default Value: CFG pin-strap setting

Units: Amperes

Equation: IOUT_AVG_OC_FAULT_LIMIT = $Y \times 2^N$

Range: -100A to 100A

COMMAND	IOUT_AVG_OC_FAULT_LIMIT (E7h)															
Format	Linear-11															
Bit Position	15	14	13	12	11	10	9	8	7	6	5	4	3	2	1	0
Access	R/W	R/W	R/W	R/W	R/W	R/W	R/W	R/W	R/W	R/W	R/W	R/W	R/W	R/W	R/W	R/W
Function	Signed Exponent, N								Signed Mantissa, Y							
Default Value	CFG Pin-strap Setting															

IOUT_AVG_UC_FAULT_LIMIT (E8h)

Definition: Sets the I_{OUT} average undercurrent fault threshold. For down-slope sensing, this corresponds to the average of all the current samples taken during the (1-D) time interval, excluding the current sense blanking time (which occurs at the beginning of the 1-D interval). For up-slope sensing, this corresponds to the average of all the current samples taken during the D time interval, excluding the current sense blanking time (which occurs at the beginning of the D interval). This feature shares the UC fault bit operation (in STATUS_IOUT) and UC fault response with IOUT_UC_FAULT_LIMIT.

Paged or Global: Paged

Data Length in Bytes: 2

Data Format: Linear-11

Type: R/W

Protectable: Yes

Default Value: -1 X IOUT_AVG_OC_FAULT_LIMIT as set by CFG pin-strap setting

Units: Amperes

Equation: IOUT_AVG_UC_FAULT_LIMIT = $Y \times 2^N$

Range: -100A to 100A

COMMAND	IOUT_AVG_UC_FAULT_LIMIT (E8h)															
Format	Linear-11															
Bit Position	15	14	13	12	11	10	9	8	7	6	5	4	3	2	1	0
Access	R/W	R/W	R/W	R/W	R/W	R/W	R/W	R/W	R/W	R/W	R/W	R/W	R/W	R/W	R/W	R/W
Function	Signed Exponent, N								Signed Mantissa, Y							
Default Value	-1 X IOUT_AVG_OC_FAULT_LIMIT as set by CFG Pin-strap Setting															

USER_GLOBAL_CONFIG (E9h)

Definition: Used to set options for output voltage sensing, VMON/TMON pin configuration, SMBus time-out, and DDC and SYNC output configurations.

Paged or Global: Global

Data Length in Bytes: 2

Data Format: Bit Field

Type: R/W

Protectable: Yes

Default Value: Set by CFG pin-strap setting

Units: N/A

COMMAND	USER_GLOBAL_CONFIG (E9h)															
Format	Bit Field															
Bit Position	15	14	13	12	11	10	9	8	7	6	5	4	3	2	1	0
Access	R/W	R/W	R/W	R/W	R/W	R/W	R/W	R/W	R/W	R/W	R/W	R/W	R/W	R/W	R/W	R/W
Function	See Following Table															
Default Value	Set by CFG Pin-strap Setting															

BITS	PURPOSE	VALUE	DESCRIPTION
15:13	Not Used	000000	Not used
12	VMON/TMON Config	0	MFR_READ_VMON returns voltage on VMON pin in Volts. External 16:1 voltage divider needed on VMON/TMON pin (pin 6) to voltage being monitored.
		1	READ_TEMPERATURE_3 returns TMON in °C. External 2:1 voltage divider needed on VMON/TMON pin (pin 6) to SPS TMON pin.
11:10	Not Used	00	Not used
9:8	VSENSE Select for monitoring and fault detection	00	Output 0 uses VSEN0, Output 1 uses VSEN1
		01	Both outputs use VSEN0
		10-11	Not used
7	Not Used	0	Not used
6	DDC output Configuration	0	DDC output open-drain
		1	DDC output push-pull
5	Not Used	0	Not used
4	Disable SMBus Time-Outs	0	SMBus time-outs enabled
		1	SMBus time-outs disabled
3	Not Used	0	Not used
2:1	Sync I/O Control	00	Use internal clock (frequency initially set with pin-strap)
		01	Use internal clock and output internal clock (not for use with pin-strap)
		10	Use external clock
		11	Not used
0	Not Used	0	Not used

SNAPSHOT (EAh)

Definition: A 32-byte read-back of parametric and status values. It allows monitoring and status data to be stored to flash either during a fault condition or through a system-defined time using the SNAPSHOT_CONTROL command. Snapshot is continuously updated in RAM and can be read using the SNAPSHOT command. When a fault occurs, the latest snapshot in RAM is stored to flash. Snapshot data can read back by writing a 01h to the SNAPSHOT_CONTROL command, then reading SNAPSHOT.

Paged or Global: Paged

Data Length in Bytes: 32

Data Format: Bit Field

Type: Block Read

Protectable: No

Default Value: N/A

Units: N/A

BYTE NUMBER	VALUE	PMBus COMMAND	FORMAT
31:23	Not Used	Not Used	0000h
22	Flash Memory Status Byte	N/A	Bit Field
21	Manufacturer Specific Status Byte	STATUS_MFR_SPECIFIC (80h)	1 Byte Bit Field
20	CML Status Byte	STATUS_CML (7Eh)	1 Byte Bit Field
19	Temperature Status Byte	STATUS_TEMPERATURE (7Dh)	1 Byte Bit Field
18	Input Status Byte	STATUS_INPUT (7Ch)	1 Byte Bit Field
17	I _{OUT} Status Byte	STATUS_IOUT (7Bh)	1 Byte Bit Field
16	V _{OUT} Status Byte	STATUS_VOUT (7Ah)	1 Byte Bit Field
15:14	Switching Frequency	READ_FREQUENCY (95h)	2 Byte Linear-11
13:12	External Temperature	READ_TEMPERATURE_2 (8Eh)	2 Byte Linear-11
11:10	Internal Temperature	READ_TEMPERATURE_1 (8Dh)	2 Byte Linear-11
9:8	Duty Cycle	READ_DUTY_CYCLE (94h)	2 Byte Linear-11
7:6	Highest Measured Output Current	N/A	2 Byte Linear-11
5:4	Output Current	READ_IOUT (8Ch)	2 Byte Linear-11
3:2	Output Voltage	READ_VOUT (8Bh)	2 Byte Linear-16 Unsigned
1:0	Input Voltage	READ_VIN (88h)	2 Byte Linear-11

LEGACY_FAULT_GROUP (F0h)

Definition: Allows the ZL8802 to sequence and fault spread with devices other than the ZL8800 family of ICs. This command sets which rail DDC IDs should be listened to for fault spreading information. The data sent is a 4-byte, 32-bit bit vector where every bit represents a rail's DDC ID. A bit set to 1 indicates a device DDC ID to which the configured device will respond upon receiving a fault spreading event. In this vector, bit 0 of byte 0 corresponds to the rail with DDC ID 0. Following through, Bit 7 of byte 3 corresponds to the rail with DDC ID 31.

NOTE: The device/rail's own DDC ID should not be set within the LEGACY_FAULT_GROUP command for that device/rail.

All devices in a current share rail (devices other than the ZL8800 family ICs) must shut down for the rail to report a shutdown.

If fault spread mode is enabled in USER_CONFIG, the device will immediately shut down if on of its DDC_GROUP members fail. The device/rail will attempt its configured restart only after all devices/rails within the DDC_GROUP have cleared their faults.

If fault spread mode is disabled in USER_CONFIG, the device will perform a sequenced shutdown as defined by the SEQUENCE command setting. The rails/devices in a sequencing set only attempt their configured restart after all faults have cleared within the DDC_GROUP. If fault spread mode is disabled and sequencing is also disabled, the device will ignore faults from other devices and stay enabled.

Paged or Global: Paged

Data Length in Bytes: 4

Data Format: Bit field

Type: Block R/W

Protectable: Yes

Default Value: 00000000h

Units: N/A

COMMAND	LEGACY_FAULT_GROUP (F0h)															
Format	Bit Field															
Bit Position	31	30	29	28	27	26	25	24	23	22	21	20	19	18	17	16
Access	R/W	R/W	R/W	R/W	R/W	R/W	R/W	R/W	R/W	R/W	R/W	R/W	R/W	R/W	R/W	R/W
Function	See Following Table															
Default Value	0	0	0	0	0	0	0	0	0	0	0	0	0	0	0	0
Format	Bit Field															
Bit Position	15	14	13	12	11	10	9	8	7	6	5	4	3	2	1	0
Access	R/W	R/W	R/W	R/W	R/W	R/W	R/W	R/W	R/W	R/W	R/W	R/W	R/W	R/W	R/W	R/W
Function	See Following Table															
Default Value	0	0	0	0	0	0	0	0	0	0	0	0	0	0	0	0

BIT	FIELD NAME	VALUE	SETTING	DESCRIPTION
31:0	Fault Group	NA	00000000h	Identifies the devices in the fault spreading group.

SNAPSHOT_CONTROL (F3h)

Definition: Writing a 01h will cause the device to copy the current SNAPSHOT values from NVRAM to the 32-byte SNAPSHOT command parameter. Writing a 02h will cause the device to write the current SNAPSHOT values to NVRAM, 03h will erase all SNAPSHOT values from NVRAM. Write (02h) and Erase (03h) can only be used when the device is disabled. All other values will be ignored. SNAPSHOT 03h must be written to the device when the device is DISABLED. Data will not be updated, or written to NVRAM after a fault occurs until the SNAPSHOT 03h command has been written.

Paged or Global: Paged

Data Length in Bytes: 1

Data Format: Bit Field

Type: R/W Byte

Protectable: Yes

Default Value: 00h

Units: N/A

COMMAND	SNAPSHOT_CONTROL (F3h)							
Format	Bit Field							
Bit Position	7	6	5	4	3	2	1	0
Access	R/W	R/W	R/W	R/W	R/W	R/W	R/W	R/W
Function	See Following Table							
Default Value	0	0	0	0	0	0	0	0

VALUE	DESCRIPTION
01	Read SNAPSHOT values from NVRAM
02	Write SNAPSHOT values to NVRAM
03	Erase SNAPSHOT values from NVRAM

RESTORE_FACTORY (F4h)

Definition: Restores the device to the hard-coded factory default values and pin-strap definitions. The device retains the DEFAULT and USER stores for restoring. Security level is changed to Level 1 following this command.

Paged or Global: Global

Data Length in Bytes: 0

Data Format: N/A

Type: Write Only

Protectable: Yes

Default Value: N/A

Units: N/A

MFR_VMON_OV_FAULT_LIMIT (F5h)

Definition: Sets the VMON over-temperature fault threshold. The VMON overvoltage warn limit is automatically set to 90% of this fault value. If VMON is not used, set VMON_OV_FAULT_RESPONSE to 00h, which will disable VMON OV faults entirely.

Paged or Global: Global

Data Length in Bytes: 2

Data Format: Linear-11

Type: R/W

Protectable: Yes

Default Value: C266h (2.4V)

Units: Volts

Equation: $MFR_VMON_OV_FAULT_LIMIT = Y \times 2^N$

Range: 0 to 20V

COMMAND	MFR_VMON_OV_FAULT_LIMIT (F5h)															
Format	Linear-11															
Bit Position	15	14	13	12	11	10	9	8	7	6	5	4	3	2	1	0
Access	R/W	R/W	R/W	R/W	R/W	R/W	R/W	R/W	R/W	R/W	R/W	R/W	R/W	R/W	R/W	R/W
Function	Signed Exponent, N					Signed Mantissa, Y										
Default Value	1	1	1	0	0	0	1	0	0	1	1	0	0	1	1	0

MFR_VMON_UV_FAULT_LIMIT (F6h)

Definition: Sets the VMON undervoltage fault threshold. The VMON undervoltage warn limit is automatically set to 110% of this fault value. If VMON is not used, set VMON_UV_FAULT_RESPONSE to 00h, which will disable VMON UV faults entirely.

Paged or Global: Global

Data Length in Bytes: 2

Data Format: Linear-11

Type: R/W

Protectable: Yes

Default Value: B0CCh (0.2V)

Units: Volts

Equation: $MFR_VMON_UV_FAULT_LIMIT = Y \times 2^N$

Range: 0 to 20V

COMMAND	MFR_VMON_UV_FAULT_LIMIT (F6h)															
Format	Linear-11															
Bit Position	15	14	13	12	11	10	9	8	7	6	5	4	3	2	1	0
Access	R/W	R/W	R/W	R/W	R/W	R/W	R/W	R/W	R/W	R/W	R/W	R/W	R/W	R/W	R/W	R/W
Function	Signed Exponent, N					Signed Mantissa, Y										
Default Value	1	0	1	1	0	0	0	0	1	1	0	0	1	1	0	0

MFR_READ_VMON (F7h)**Definition:** Reads the voltage on the VMON pin.**Paged or Global:** Global**Data Length in Bytes:** 2**Data Format:** Linear-11**Type:** R/W**Protectable:** No**Default Value:** N/A**Units:** °C**Equation:** $MFR_READ_VMON = Y \times 2^N$ **Range:** -200°C to +200°C

COMMAND	MFR_READ_VMON (F7h)															
Format	Linear-11															
Bit Position	15	14	13	12	11	10	9	8	7	6	5	4	3	2	1	0
Access	R/W	R/W	R/W	R/W	R/W	R/W	R/W	R/W	R/W	R/W	R/W	R/W	R/W	R/W	R/W	R/W
Function	Signed Exponent, N								Signed Mantissa, Y							
Default Value	N/A	N/A	N/A	N/A	N/A	N/A	N/A	N/A	N/A	N/A	N/A	N/A	N/A	N/A	N/A	N/A

VMON_OV_FAULT_RESPONSE (F8h)**Definition:** Configures the VMON overvoltage fault response as defined by the table below. Note: The retry time is the time between restart attempts. If VMON is not used, set this response to 00h, which will disable VMON OV faults entirely.**Paged or Global:** Global**Data Length in Bytes:** 1**Data Format:** Bit Field**Type:** R/W**Protectable:** Yes**Default Value:** BFh (continuous retries)**Units:** N/A

COMMAND	VMON_OV_FAULT_RESPONSE (F8h)							
Format	Bit Field							
Bit Position	7	6	5	4	3	2	1	0
Access	R/W	R/W	R/W	R/W	R/W	R/W	R/W	R/W
Function	See Following Table							
Default Value	1	0	1	1	1	1	1	1

BIT	FIELD NAME	VALUE	DESCRIPTION
7:6	Response behavior, the device: • Pulls SALRT low • Sets the related fault bit in the status registers. Fault bits are only cleared by the CLEAR_FAULTS command.	00	Ignore faults
		01	Not used
		10	Disable without delay and retry according to the setting in bits 5:3.
		11	Output is disabled while the fault is present. Operation resumes and the output is enabled when VMON falls below 95% of the VMON_OV_FAULT_LIMIT setting.
5:3	Retry Setting	000	No retry. The output remains disabled until the fault is cleared.
		001-110	Not used
		111	Attempts to restart continuously, without checking if the fault is still present, until it is commanded OFF (by the CONTROL pin or OPERATION command or both), bias power is removed, or another fault condition causes the unit to shut down. A retry is attempted after VMON falls below 95% of the VMON_OV_FAULT_LIMIT. The time between the start of each attempt to restart is set by the value in bits [2:0] multiplied by 35ms.
2:0	Retry Delay	000-111	Retry delay time = (Value +1) * 35ms. Sets the time between retries in 35ms increments. Range is 35ms to 280ms.

VMON_UV_FAULT_RESPONSE (F9h)

Definition: Configures the VMON undervoltage fault response as defined by the table below. Note: The retry time is the time between restart attempts. If VMON is not used, set this response to 00h, which will disable VMON UV faults entirely.

Paged or Global: Global

Data Length in Bytes: 1

Data Format: Bit Field

Type: R/W

Protectable: Yes

Default Value: BFh (continuous retries)

Units: Retry time unit = 35ms

COMMAND	VMON_UV_FAULT_RESPONSE (F9h)							
Format	Bit Field							
Bit Position	7	6	5	4	3	2	1	0
Access	R/W	R/W	R/W	R/W	R/W	R/W	R/W	R/W
Function	See Following Table							
Default Value	1	0	1	1	1	1	1	1

BIT	FIELD NAME	VALUE	DESCRIPTION
7:6	Response behavior, the device: • Pulls SALRT low • Sets the related fault bit in the status registers. Fault bits are only cleared by the CLEAR_FAULTS command.	00	Fault ignored
		01	Not used
		10	Disable without delay and retry according to the setting in bits 5:3.
		11	Output is disabled while the fault is present. Operation resumes and the output is enabled when VMON rises above 105% of the VMON_UV_FAULT_LIMIT setting.
5:3	Retry Setting	000	No retry. The output remains disabled until the fault is cleared.
		001-110	Not used
		111	Attempts to restart continuously, without checking if the fault is still present, until it is commanded OFF (by the CONTROL pin or OPERATION command or both), bias power is removed, or another fault condition causes the unit to shut down. A retry is attempted after VMON has risen above 105% of VMON_UV_FAULT_LIMIT. The time between the start of each attempt to restart is set by the value in bits [2:0] multiplied by 35ms.
2:0	Retry Delay	000-111	Retry delay time = (Value +1) * 35ms. Sets the time between retries in 35ms increments. Range is 35ms to 280ms.

SECURITY_LEVEL (FAh)

Definition: The device provides write protection for individual commands. Each bit in the UNPROTECT parameter controls whether its corresponding command is writable (commands are always readable). If a command is not writable, a password must be entered to change its parameter (that is, to enable writes to that command). Passwords can be either public or private. The public password provides a simple lock-and-key protection against accidental changes to the device. It would typically be sent to the device in the application before making changes. Private passwords allow commands marked as nonwritable in the UNPROTECT parameter to be changed. Private passwords are intended for protecting default-installed configurations and would not typically be used in the application. Each store (USER and DEFAULT) can have its own UNPROTECT string and private password. If a command is marked as nonwritable in the DEFAULT UNPROTECT parameter (its corresponding bit is cleared), the private password in the DEFAULT store must be sent to change that command. If a command is writable according to the default UNPROTECT parameter, it may still be marked as nonwritable in the user store UNPROTECT parameter. In this case, the user private password can be sent to make the command writable.

The device supports four levels of security. Each level is designed to be used by a particular class of users, ranging from module manufacturers to end users, as discussed below. Levels 0 and 1 correspond to the public password. All other levels require a private password. Writing a private password can only raise the security level. Writing a public password will reset the level down to 0 or 1.

[Figure 12 on page 88](#) shows the algorithm used by the device to determine if a particular command write is allowed.

Paged or Global: Global

Data Length in Bytes: 1

Data Format: Hex

Type: Read Byte

Protectable: No

Default Value: 01h

Units: N/A

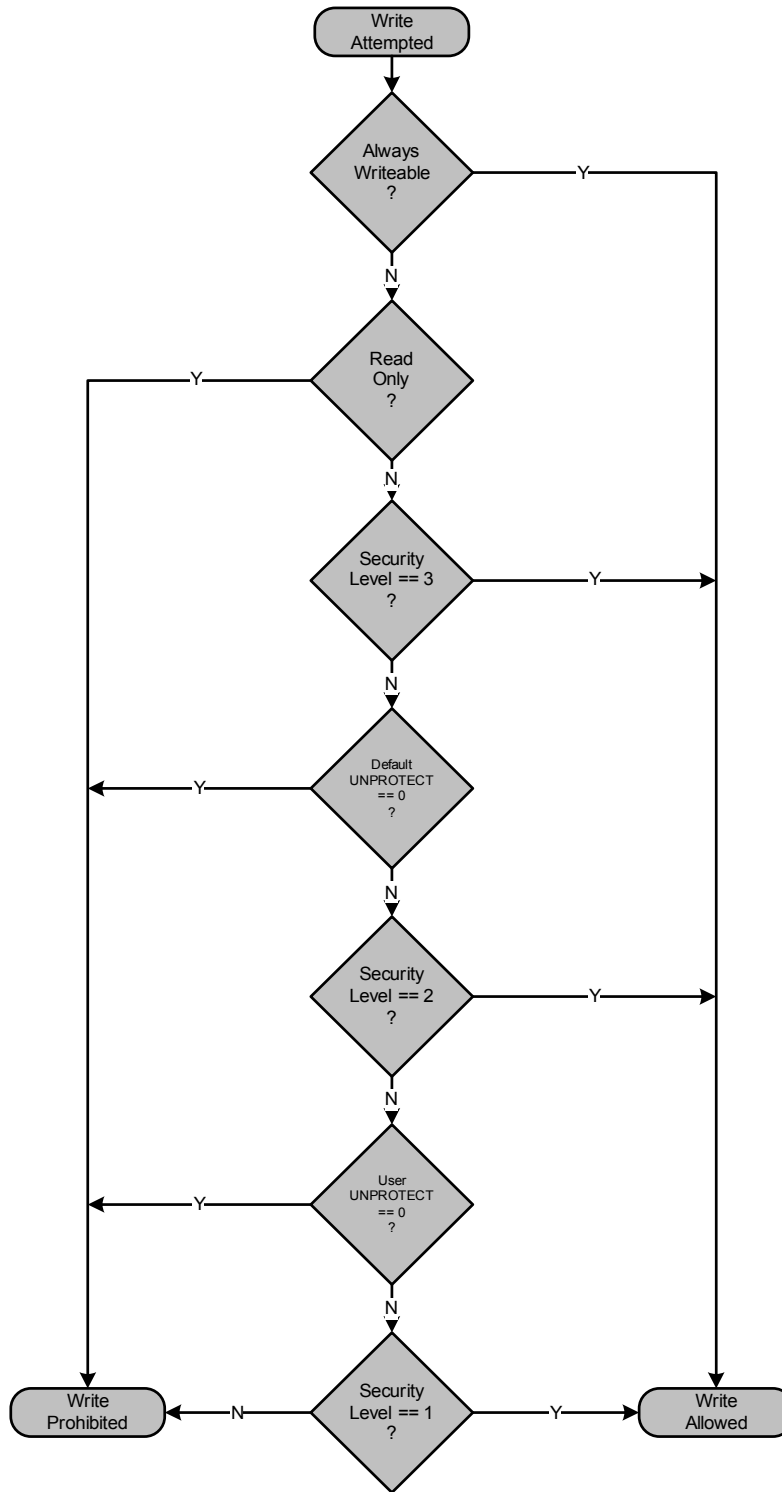

FIGURE 12. ALGORITHM TO DETERMINE WHEN A COMMAND IS WRITABLE

Security Level 3 – Module Vendor

Level 3 is intended primarily for use by module vendors to protect device configurations in the default store. Clearing a UNPROTECT bit in the default store implies that a command is writable only at Level 3 and above. The device’s security level is raised to Level 3 by writing the private password value previously stored in the default store. To be effective, the module vendor must clear the UNPROTECT bit corresponding to the STORE_DEFAULT_ALL and RESTORE_DEFAULT commands. Otherwise, Level 3 protection is ineffective because the entire store could be replaced by the user, including the enclosed private password.

Security Level 2 – User

Level 2 is intended for use by the end user of the device. Clearing a UNPROTECT bit in the user store implies that a command is writable only at Level 2 and above. The device's security level is raised to Level 2 by writing the private password value previously stored in the User Store. To be effective, the user must clear the UNPROTECT bit corresponding to the STORE_USER_ALL, RESTORE_DEFAULT_ALL, STORE_DEFAULT_ALL, and RESTORE_DEFAULT commands. Otherwise, Level 2 protection is ineffective because the entire store could be replaced, including the enclosed private password.

Security Level 1 – Public

Level 1 is intended to protect against accidental changes to ordinary commands by providing a global write-enable. It can be used to protect the device from erroneous bus operations. It provides access to commands whose UNPROTECT bit is set in both the default and User Store. Security is raised to Level 1 by writing the public password stored in the user store using the PUBLIC_PASSWORD command. The public password stored in the default store has no effect.

Security Level 0 - Unprotected

Level 0 implies that only commands which are always writable (e.g., PUBLIC_PASSWORD) are available. This represents the lowest authority level and hence the most protected state of the device. The level can be reduced to 0 by using PUBLIC_PASSWORD to write any value which does not match the stored public password.

PRIVATE_PASSWORD (FBh)

Definition: Sets the private password string.

Paged or Global: Global

Data Length in Bytes: 9

Data Format: ASCII. ISO/IEC 8859-1

Type: Block R/W

Protectable: No

Default Value: 000000000000000000h

Units: N/A

PUBLIC_PASSWORD (FCh)

Definition: Sets the public password string.

Paged or Global: Global

Data Length in Bytes: 4

Data Format: ASCII. ISO/IEC 8859-1

Type: Block R/W

Protectable: No

Default Value: 00000000h

Units: N/A

UNPROTECT (FDh)

Definition: Sets a 256-bit (32-byte) parameter which identifies which commands are to be protected against write-access at lower security levels. Each bit in this parameter corresponds to a command according to the command's code. The command with a code of 00h (PAGE) is protected by the least-significant bit of the least-significant byte, followed by the command with a code of 01h and so forth. Note that all possible commands have a corresponding bit regardless of whether they are protectable or supported by the device. Clearing a command's UNPROTECT bit indicates that write-access to that command is only allowed if the device's security level has been raised to an appropriate level. The UNPROTECT bits in the default store require a security level 3 or greater to be writable. The UNPROTECT bits in the user store require a security level of 2 or higher.

Data Length in Bytes: 32

Paged or Global: Global

Data Format: Custom

Type: Block R/W

Protectable: No

Default Value: FF...FFh

Units: N/A

Revision History

The revision history provided is for informational purposes only and is believed to be accurate, but not warranted. Please visit our website to make sure you have the latest revision.

DATE	REVISION	CHANGE
Nov 8, 2017	FN8760.3	Changed all SPS references from ISL99227 to ISL99227B. Added an explanation of the EN0 and EN1 timing restrictions to "Enable Pin Operation and Timing" on page 16. Updated to the current Renesas format.
May 25, 2017	FN8760.2	Changed ISL99226 to ISL99227 in Figure 1 on page 3. Added Related Literature section. Updated disclaimer.
Dec 11, 2015	FN8760.1	Added Junction Temperature to the "Thermal Information" on page 8. Added ZL8802ALAF7A to the ordering information table on page 7.
Aug 6, 2015	FN8760.0	Initial release

About Intersil

Intersil Corporation is a leading provider of innovative power management and precision analog solutions. The company's products address some of the largest markets within the industrial and infrastructure, mobile computing, and high-end consumer markets.

For the most updated datasheet, application notes, related documentation, and related parts, see the respective product information page found at www.intersil.com.

For a listing of definitions and abbreviations of common terms used in our documents, visit www.intersil.com/glossary.

You can report errors or suggestions for improving this datasheet by visiting www.intersil.com/ask.

Reliability reports are also available from our website at www.intersil.com/support.

© Copyright Intersil Americas LLC 2015-2017. All Rights Reserved.
All trademarks and registered trademarks are the property of their respective owners.

For additional products, see www.intersil.com/en/products.html

Intersil products are manufactured, assembled and tested utilizing ISO9001 quality systems as noted in the quality certifications found at www.intersil.com/en/support/qualandreliability.html

Intersil products are sold by description only. Intersil may modify the circuit design and/or specifications of products at any time without notice, provided that such modification does not, in Intersil's sole judgment, affect the form, fit or function of the product. Accordingly, the reader is cautioned to verify that datasheets are current before placing orders. Information furnished by Intersil is believed to be accurate and reliable. However, no responsibility is assumed by Intersil or its subsidiaries for its use; nor for any infringements of patents or other rights of third parties which may result from its use. No license is granted by implication or otherwise under any patent or patent rights of Intersil or its subsidiaries.

For information regarding Intersil Corporation and its products, see www.intersil.com

Package Outline Drawing

For the most recent package outline drawing, see [L44.7x7B](#).

L44.7x7B

44 LEAD QUAD FLAT NO-LEAD PLASTIC PACKAGE

Rev 0, 10/09

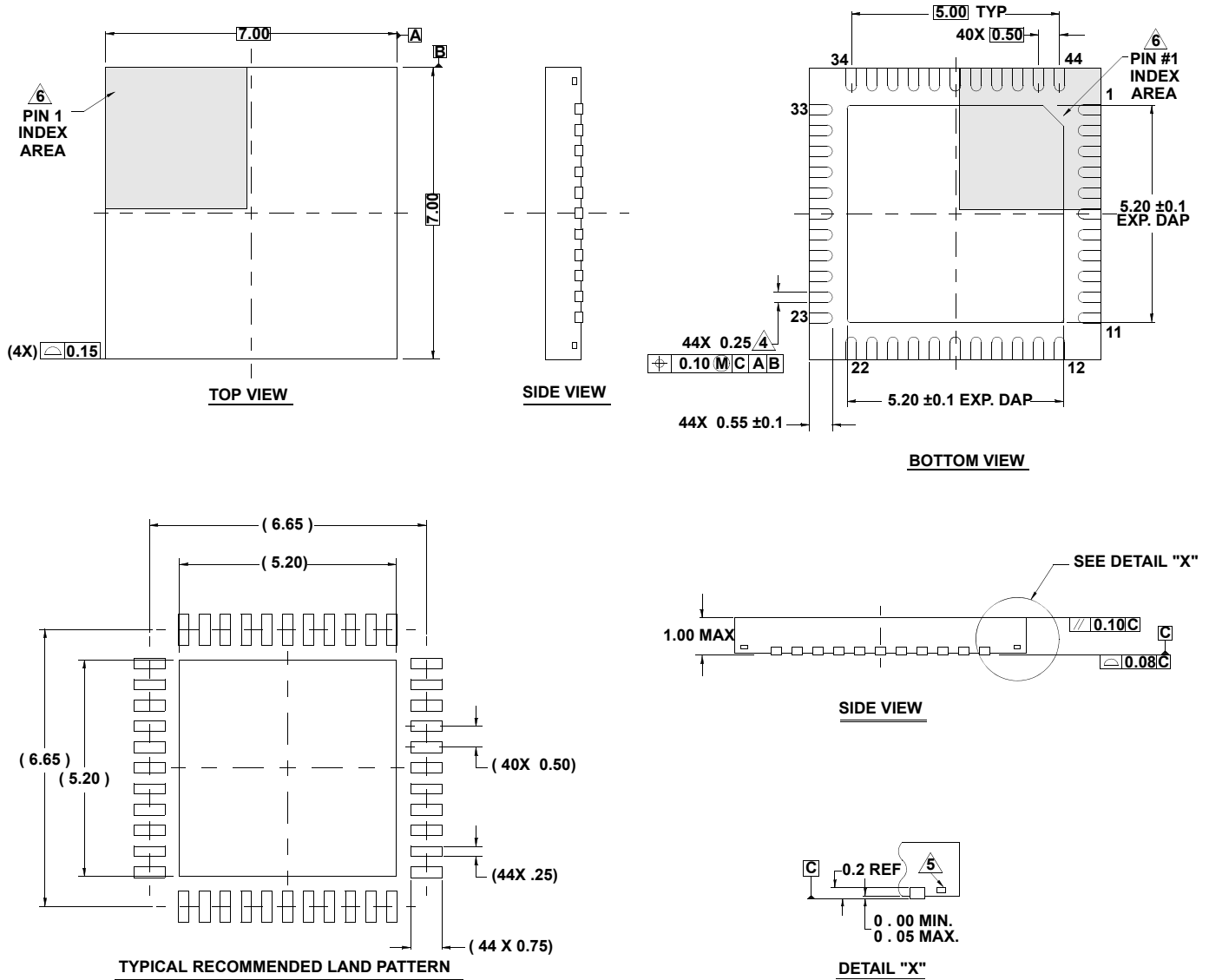

NOTES:

1. Dimensions are in millimeters.
Dimensions in () for Reference Only.
2. Dimensioning and tolerancing conform to AMSE Y14.5m-1994.
3. Unless otherwise specified, tolerance : Decimal ± 0.05
4. Dimension b applies to the metallized terminal and is measured between 0.15mm and 0.30mm from the terminal tip.
5. Tiebar shown (if present) is a non-functional feature.
6. The configuration of the pin #1 identifier is optional, but must be located within the zone indicated. The pin #1 identifier may be either a mold or mark feature.
7. Complies to JEDEC MO220 VKKD-1.

Looking for pricing, stock, or lifecycle information?

Click below to explore more details on WIN SOURCE:

-  [View ZL8802ALAFT on WIN SOURCE](#)
-  [Renesas Electronics America](#) Information

Optimize Your Supply Chain with WIN SOURCE Solutions

-  Global Sourcing Solution
-  Obsolete Management
-  Cost Control Management
-  Shortage Management
-  Alternative Solution
-  Excess Inventory Management