



THE DATASHEET OF
74LVC2G14W6-7



Description

The 74LVC2G14 is a dual Schmitt trigger inverter gate with standard push-pull outputs. The device is designed for operation with a power supply range of 1.65V to 5.5V. The inputs are tolerant to 5.5V, allowing this device to be used in a mixed-voltage environment. The device is fully specified for partial power down applications using I_{OFF}. The I_{OFF} circuitry disables the output preventing damaging current backflow when the device is powered down.

The gate performs the positive Boolean function:

$$Y = \overline{A}$$

Features

- Wide Supply Voltage Range from 1.65V to 5.5V
- ±24mA Output Drive at 3.0V
- CMOS Low Power Consumption
- I_{OFF} Supports Partial-Power-Down Mode Operation
- Inputs Accept up to 5.5V
- ESD Protection Tested per JESD 22
 - Exceeds 2000V Human Body Model (A114)
 - Exceeds 1000V Charged Device Model (C101)
- Latch-up Exceeds 100mA per JESD 78, Class I
- X2-DFN1409-6 Package Designed as a Direct Replacement for Chip Scale Packaging
- Range of Package Options SOT26, SOT363, X1-DFN1010-6 (Type B), X2-DFN1010-6, X2-DFN1409-6, and X2-DFN1410-6
- Leadless Packages Named per JESD30E
- **Totally Lead-Free & Fully RoHS Compliant (Notes 1 & 2)**
- **Halogen and Antimony Free. "Green" Device (Note 3)**
- **For automotive applications requiring specific change control (i.e. parts qualified to AEC-Q100/101/104/200, PPAP capable, and manufactured in IATF 16949 certified facilities), please [contact us](https://www.diodes.com/quality/product-definitions/) or your local Diodes representative. <https://www.diodes.com/quality/product-definitions/>**

- Notes:
1. No purposely added lead. Fully EU Directive 2002/95/EC (RoHS), 2011/65/EU (RoHS 2) & 2015/863/EU (RoHS 3) compliant.
 2. See <https://www.diodes.com/quality/lead-free/> for more information about Diodes Incorporated's definitions of Halogen- and Antimony-free, "Green" and Lead-free.
 3. Halogen- and Antimony-free "Green" products are defined as those which contain <900ppm bromine, <900ppm chlorine (<1500ppm total Br + Cl) and <1000ppm antimony compounds.

Pin Assignments

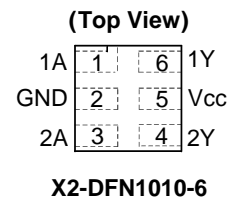
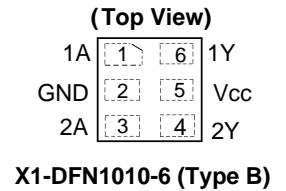
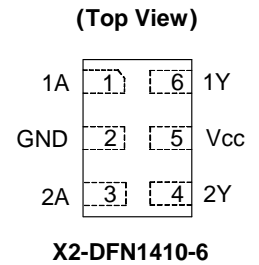
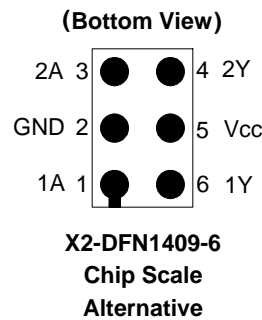
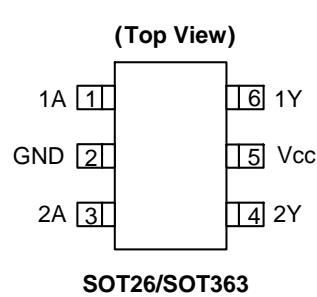

Applications

- Voltage level shifting
- General-purpose logics
- Power down signal isolations
- Wide array of products such as:
 - PCs, networking, notebooks, netbooks, tablets
 - Computer peripherals, hard drives, SSD, CD/DVD ROM
 - TV, DVD, DVR, set-top boxes
 - Cell phones, personal navigations/GPS
 - MP3 players, cameras, video recorders

Pin Descriptions

Pin Name	Pin Number	Function
1A	1	Data Input
GND	2	Ground
2A	3	Data Input
2Y	4	Data Output
V _{CC}	5	Supply Voltage
1Y	6	Data Output

Logic Diagram

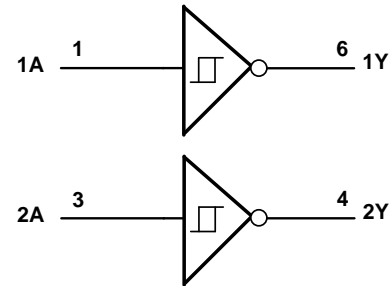

Function Table

Inputs	Output
A	Y
H	L
L	H

Absolute Maximum Ratings (Notes 4 & 5) (@T_A = +25°C, unless otherwise specified.)

Symbol	Parameter	Rating	Unit
ESD HBM	Human Body Model ESD Protection	2	kV
ESD CDM	Charged Device Model ESD Protection	1	kV
V _{CC}	Supply Voltage Range	-0.5 to +6.5	V
V _I	Input Voltage Range	-0.5 to +6.5	V
V _O	Voltage Applied to Output in High Impedance or I _{OFF} State	-0.5 to +6.5	V
V _O	Voltage Applied to Output in High or Low State	-0.3 to V _{CC} +0.5	V
I _{IK}	Input Clamp Current V _I < 0	-50	mA
I _{OK}	Output Clamp Current V _O < 0	-50	mA
I _O	Continuous Output Current	-50	mA
—	Continuous Current Through V _{DD} or GND	±100	mA
T _J	Operating Junction Temperature	-40 to +150	°C
T _{STG}	Storage Temperature	-65 to +150	°C

- Notes:
- Stresses greater than those listed under *Absolute Maximum Ratings* can cause permanent damage to the device. These are stress ratings only, and functional operation of the device at these or any other conditions beyond those indicated under *Recommended Operating Conditions* is not implied. Exposure to *Absolute Maximum Ratings* for extended periods can affect device reliability.
 - Forcing the maximum allowed voltage could cause a condition exceeding the maximum current or conversely forcing the maximum current could cause a condition exceeding the maximum voltage. The ratings of both current and voltage must be maintained within the controlled range.

Recommended Operating Conditions (Note 6) (@ $T_A = +25^\circ\text{C}$, unless otherwise specified.)

Symbol	Parameter	Min	Max	Unit	
V_{CC}	Operating Voltage	Operating	1.65	5.5	V
		Data Retention Only	1.5	—	V
V_I	Input Voltage	0	5.5	V	
V_O	Output Voltage	0	V_{CC}	V	
I_{OH}	High-Level Output Current	$V_{CC} = 1.65\text{V}$	—	-4	mA
		$V_{CC} = 2.3\text{V}$	—	-8	
		$V_{CC} = 3\text{V}$	—	-16	
		$V_{CC} = 4.5\text{V}$	—	-24	
I_{OL}	Low-Level Output Current	$V_{CC} = 1.65\text{V}$	—	4	mA
		$V_{CC} = 2.3\text{V}$	—	8	
		$V_{CC} = 3\text{V}$	—	16	
		$V_{CC} = 4.5\text{V}$	—	24	
T_A	Operating Free-Air Temperature	—	-40	+125	$^\circ\text{C}$

Note: 6. Unused inputs should be held at V_{CC} or Ground.

Electrical Characteristics (@T_A = +25°C, unless otherwise specified.)

Symbol	Parameter	Test Conditions	V _{CC}	-40°C to +85°C		-40°C to +125°C		Unit	
				Min	Max	Min	Max		
V _{T+}	Positive-Going Input Threshold Voltage	—	1.8V	0.70	1.50	0.70	1.70	V	
			2.3V	1.00	1.80	1.00	2.00		
			3V	1.30	2.20	1.30	2.40		
			4.5V	1.90	3.10	1.90	3.30		
			5.5V	2.20	3.60	2.20	3.80		
V _{T-}	Negative-Going Input Threshold Voltage	—	1.8V	0.25	0.90	0.25	1.10	V	
			2.3V	0.40	1.15	0.4	1.35		
			3V	0.60	1.50	0.6	1.7		
			4.5V	1.00	2.00	1	2.2		
			5.5V	1.20	2.30	1.2	2.5		
ΔV _T	Hysteresis (V _{T+} - V _{T-})	—	1.8V	0.15	1.00	0.15	1.20	V	
			2.3V	0.25	1.10	0.25	1.30		
			3V	0.40	1.20	0.40	1.40		
			4.5V	0.60	1.50	0.60	1.70		
			5.5V	0.70	1.70	0.70	1.90		
V _{OH}	High-Level Output Voltage	I _{OH} = -100μA	1.65V to 5.5V	V _{CC} - 0.1	—	V _{CC} - 0.1	—	V	
		I _{OH} = -4mA	1.65V	1.2	—	0.95	—		
		I _{OH} = -8mA	2.3V	1.9	—	1.7	—		
		I _{OH} = -16mA	3V	2.4	—	2.2	—		
		I _{OH} = -24mA		2.3	—	2.0	—		
		I _{OH} = -32mA	4.5V	3.8	—	3.4	—		
V _{OL}	Low-Level Output Voltage	I _{OL} = 100μA	1.65V to 5.5V	—	0.1	—	0.10	V	
		I _{OL} = 4mA	1.65V	—	0.45	—	0.70		
		I _{OL} = 8mA	2.3V	—	0.3	—	0.45		
		I _{OL} = 16mA	3V	—	—	0.4	—		0.60
		I _{OL} = 24mA		—	—	0.55	—		0.80
		I _{OL} = 32mA	4.5V	—	—	0.55	—		0.80
I _I	Input Current	V _I = 5.5V or GND	0 to 5.5V	—	± 5	—	±20	μA	
I _{OFF}	Power Down Leakage Current	V _I or V _O = 5.5V	0	—	± 10	—	±20	μA	
I _{CC}	Supply Current	V _I = 5.5V or GND I _O = 0	1.65V to 5.5V	—	10	—	40	μA	

Package Characteristics (@ $T_A = +25^\circ\text{C}$, $V_{CC} = 3.3\text{V}$, unless otherwise specified.)

Symbol	Parameter	Package	Conditions	Min	Typ	Max	Unit
C_I	Input Capacitance	Typical of all packages	$V_{CC} = 3.3\text{V}$ $V_I = V_{CC}$ or GND	—	3.5	—	pF
θ_{JA}	Thermal Resistance Junction-to-Ambient	SOT26	(Note 7)	—	204	—	$^\circ\text{C/W}$
		SOT363		—	371	—	
		X2-DFN1410-6		—	430	—	
		X2-DFN1409-6		—	450	—	
		X1-DFN1010-6 (Type B)		—	495	—	
		X2-DFN1010-6		—	510	—	
θ_{JC}	Thermal Resistance Junction-to-Case	SOT26	(Note 7)	—	52	—	$^\circ\text{C/W}$
		SOT363		—	143	—	
		X2-DFN1410-6		—	190	—	
		X2-DFN1409-6		—	225	—	
		X1-DFN1010-6 (Type B)		—	245	—	
		X2-DFN1010-6		—	250	—	

Note: 7. Test condition for all packages: Device mounted on FR-4 substrate PC board, 2oz copper with minimum recommended pad layout.

Switching Characteristics

$T_A = -40^\circ\text{C}$ to $+85^\circ\text{C}$, $C_L = 30$ or 50pF (See Figure 1)

Parameter	From (Input)	To (Output)	$V_{CC} = 1.8\text{V} \pm 0.15\text{V}$		$V_{CC} = 2.5\text{V} \pm 0.2\text{V}$		$V_{CC} = 3.3\text{V} \pm 0.3\text{V}$		$V_{CC} = 5\text{V} \pm 0.5\text{V}$		Unit
			Min	Max	Min	Max	Min	Max	Min	Max	
t_{PD}	A	Y	0.5	11.0	0.5	6.5	0.5	6.0	0.5	4.3	ns

$T_A = -40^\circ\text{C}$ to $+125^\circ\text{C}$, $C_L = 30$ or 50pF (See Figure 1)

Parameter	From (Input)	To (Output)	$V_{CC} = 1.8\text{V} \pm 0.15\text{V}$		$V_{CC} = 2.5\text{V} \pm 0.2\text{V}$		$V_{CC} = 3.3\text{V} \pm 0.3\text{V}$		$V_{CC} = 5\text{V} \pm 0.5\text{V}$		Unit
			Min	Max	Min	Max	Min	Max	Min	Max	
t_{PD}	A	Y	0.5	12.0	0.5	7.2	0.5	6.7	0.5	4.7	ns

Operating Characteristics

$T_A = +25^\circ\text{C}$

Parameter	Test Conditions	$V_{CC} = 1.8\text{V}$	$V_{CC} = 2.5\text{V}$	$V_{CC} = 3.3\text{V}$	$V_{CC} = 5\text{V}$	Unit
		Typ	Typ	Typ	Typ	
C_{PD}	Power Dissipation Capacitance $f = 10\text{MHz}$	17	19	20	21	pF

Parameter Measurement Information

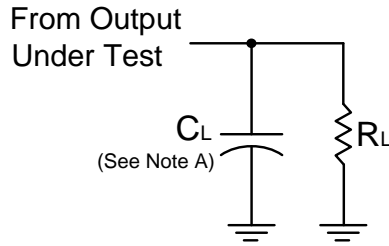

V _{CC}	Inputs		V _M	C _L	R _L
	V _I	t _R /t _F			
1.8V ± 0.15V	V _{CC}	≤ 2ns	V _{CC} /2	30pF	1kΩ
2.5V ± 0.2V	V _{CC}	≤ 2ns	V _{CC} /2	30pF	500Ω
3.3V ± 0.3V	3V	≤ 2.5ns	1.5V	50pF	500Ω
5V ± 0.5V	V _{CC}	≤ 2.5ns	V _{CC} /2	50pF	500Ω

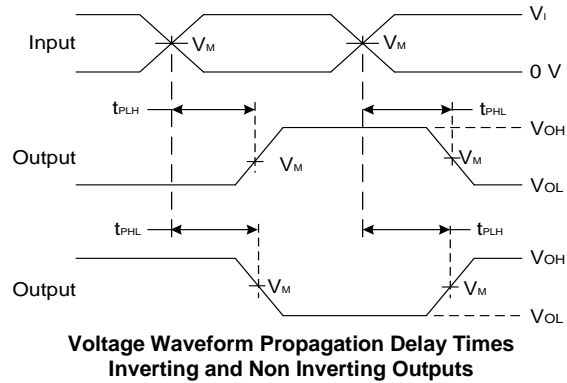
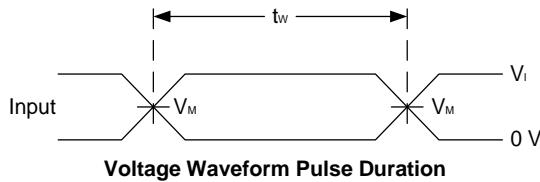
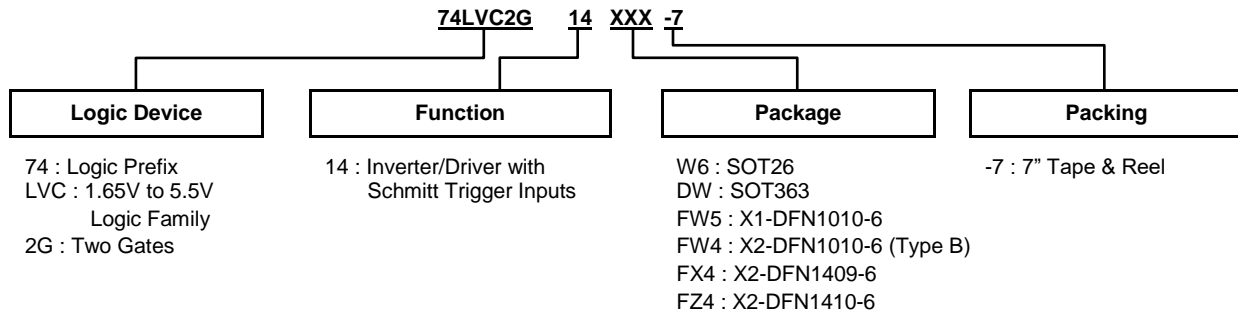

Figure 1 Load Circuit and Voltage Waveforms

- Notes:
- A. Includes test lead and test apparatus capacitance.
 - B. All pulses are supplied at pulse repetition rate ≤ 10MHz.
 - C. Inputs are measured separately one transition per measurement.
 - D. t_{PLH} and t_{PHL} are the same as t_{PD}.

Ordering Information



Part Number	Part Number Suffix	Package Code	Package (Note 8)	Package Size	Packing (Note 9)	
					Qty.	Carrier
74LVC2G14W6-7	-7	W6	SOT26	2.8mm x 2.2mm x 1.1mm 0.95mm Lead Pitch	3000	Tape & Reel
74LVC2G14DW-7	-7	DW	SOT363	2.0mm x 2.0mm x 1.1mm 0.65mm Lead Pitch	3000	Tape & Reel
74LVC2G14FW5-7	-7	FW5	X1-DFN1010-6 (Type B)	1.0mm x 1.0mm x 0.5mm 0.35mm Pad Pitch	5000	Tape & Reel
74LVC2G14FW4-7	-7	FW4	X2-DFN1010-6	1.0mm x 1.0mm x 0.4mm 0.35mm Pad Pitch	5000	Tape & Reel
74LVC2G14FX4-7	-7	FX4	X2-DFN1409-6 Chip Scale Alternative	1.4mm x 0.9mm x 0.4mm 0.5mm Pad Pitch	5000	Tape & Reel
74LVC2G14FZ4-7	-7	FZ4	X2-DFN1410-6	1.4mm x 1.0mm x 0.4mm 0.5mm Pad Pitch	5000	Tape & Reel

Notes: 8. Pad layout as shown on our suggested pad layout, which can be found on our website at <http://www.diodes.com/package-outlines.html>.
9. The taping orientation is located on our website <https://www.diodes.com/assets/Packaging-Support-Docs/ap02007.pdf>.

Marking Information

(1) SOT26, SOT363

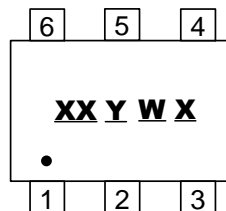

XX: Identification Code
Y: Year 0 to 9 (ex: 2 = 2022)
W: Week: A to Z: Week 1 to 26;
a to z: Week 27 to 52; z Represents
Week 52 and 53
X: A to Z: Internal Code

Part Number	Package	Identification Code
74LVC2G14W6-7	SOT26	Z5
74LVC2G14DW-7	SOT363	Z5

Marking Information (continued)

(2) X1-DFN1010-6 (Type B), X2-DFN1010-6, X2-DFN1409-6, X2-DFN1410-6

(Top View)

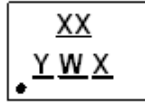

XX: Identification Code

Y: Year 0 to 9 (ex: 2 = 2022)

W: Week: A to Z: Week 1 to 26;

a to z: Week 27 to 52; z Represents
Week 52 and 53

X: A to Z: Internal Code

Part Number	Package	Identification Code
74LVC2G14FW4-7	X2-DFN1010-6	Z5
74LVC2G14FW5-7	X1-DFN1010-6 (Type B)	W5
74LVC2G14FX4-7	X2-DFN1409-6	X5
74LVC2G14FZ4-7	X2-DFN1410-6	Z5

Package Outline Dimensions

Please see <http://www.diodes.com/package-outlines.html> for the latest version.

SOT26

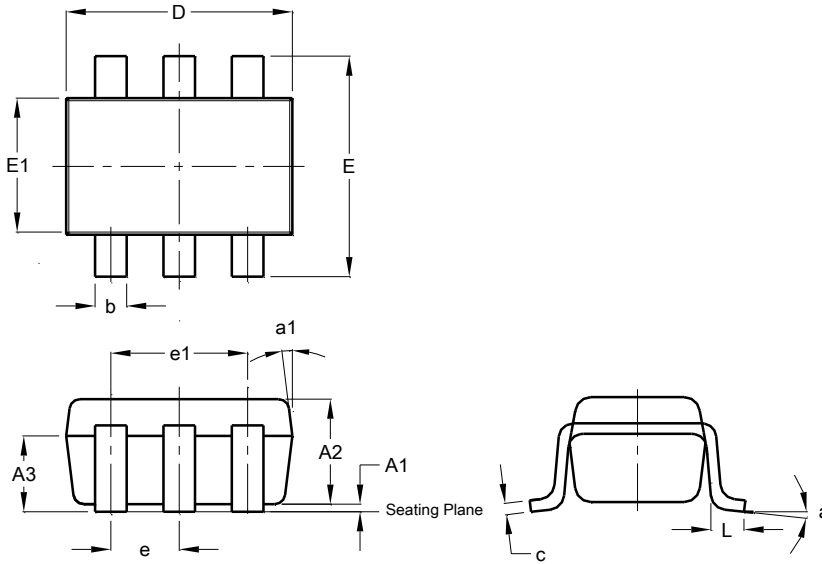

SOT26			
Dim	Min	Max	Typ
A1	0.013	0.10	0.05
A2	1.00	1.30	1.10
A3	0.70	0.80	0.75
b	0.35	0.50	0.38
c	0.10	0.20	0.15
D	2.90	3.10	3.00
e	-	-	0.95
e1	-	-	1.90
E	2.70	3.00	2.80
E1	1.50	1.70	1.60
L	0.35	0.55	0.40
a	-	-	8°
a1	-	-	7°
All Dimensions in mm			

SOT363

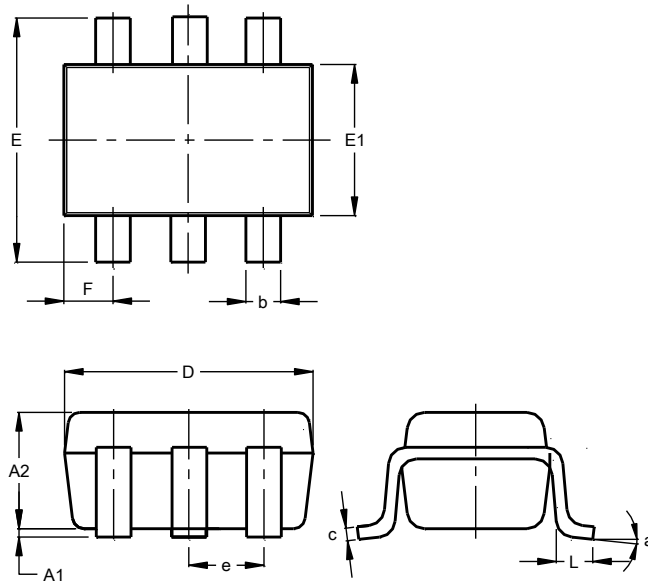

SOT363			
Dim	Min	Max	Typ
A1	0.00	0.10	0.05
A2	0.90	1.00	0.95
b	0.10	0.30	0.25
c	0.10	0.22	0.11
D	1.80	2.20	2.15
E	2.00	2.20	2.10
E1	1.15	1.35	1.30
e	0.650 BSC		
F	0.40	0.45	0.425
L	0.25	0.40	0.30
a	0°	8°	--
All Dimensions in mm			

Package Outline Dimensions (continued)

Please see <http://www.diodes.com/package-outlines.html> for the latest version.

X1-DFN1010-6 (Type B)

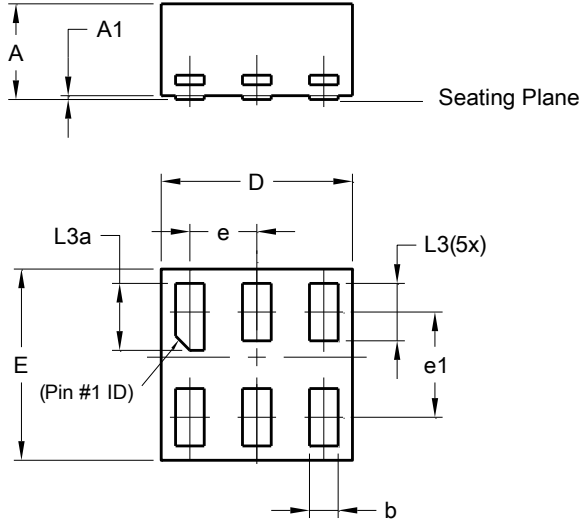

X1-DFN1010-6 (Type B)			
Dim	Min	Max	Typ
A	-	0.50	0.39
A1	-	0.04	-
b	0.12	0.20	0.15
D	0.95	1.050	1.00
E	0.95	1.050	1.00
e	0.35 BSC		
e1	0.55 BSC		
L3	0.27	0.30	0.30
L3a	0.32	0.40	0.35
All Dimensions in mm			

X2-DFN1010-6

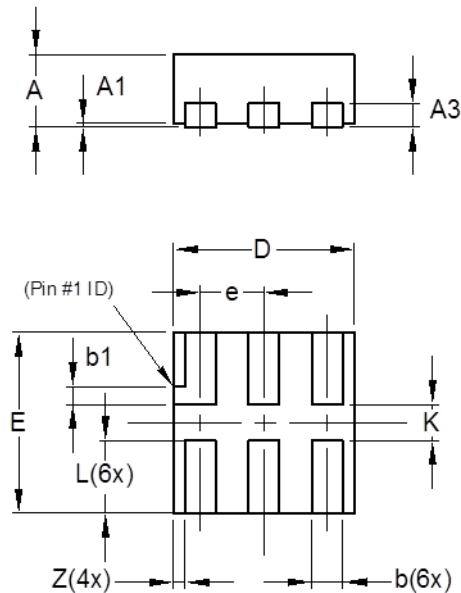

X2-DFN1010-6			
Dim	Min	Max	Typ
A	—	0.40	0.39
A1	0.00	0.05	0.02
A3	—	—	0.13
b	0.14	0.20	0.17
b1	0.05	0.15	0.10
D	0.95	1.05	1.00
E	0.95	1.05	1.00
e	—	—	0.35
L	0.35	0.45	0.40
K	0.15	—	—
Z	—	—	0.065
All Dimensions in mm			

Package Outline Dimensions (continued)

Please see <http://www.diodes.com/package-outlines.html> for the latest version.

X2-DFN1409-6

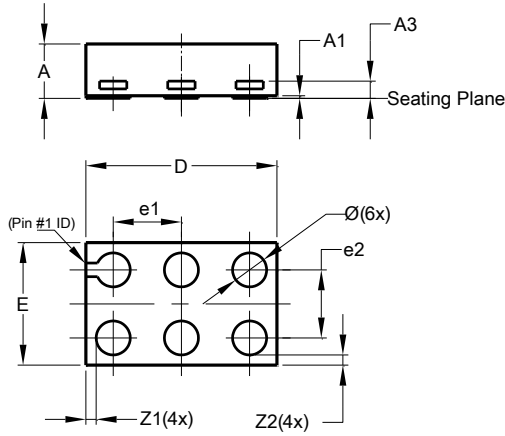

X2-DFN1409-6			
Dim	Min	Max	Typ
A	-	0.40	0.39
A1	0	0.05	0.02
A3	-	-	0.13
Ø	0.20	0.30	0.25
D	1.35	1.45	1.40
E	0.85	0.95	0.90
e1	-	-	0.50
e2	-	-	0.50
Z1	-	-	0.075
Z2	-	-	0.075
All Dimensions in mm			

X2-DFN1410-6

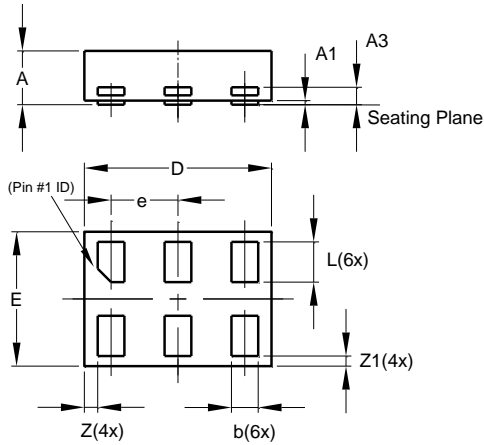

X2-DFN1410-6			
Dim	Min	Max	Typ
A	—	0.40	0.39
A1	0.00	0.05	0.02
A3	—	—	0.13
b	0.15	0.25	0.20
D	1.35	1.45	1.40
E	0.95	1.05	1.00
e	—	—	0.50
L	0.25	0.35	0.30
Z	—	—	0.10
Z1	0.045	0.105	0.075
All Dimensions in mm			

Suggested Pad Layout

Please see <http://www.diodes.com/package-outlines.html> for the latest version.

SOT26

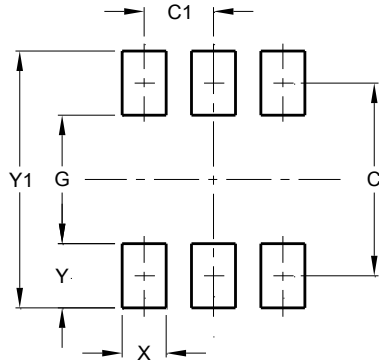

Dimensions	Value (in mm)
C	2.40
C1	0.95
G	1.60
X	0.55
Y	0.80
Y1	3.20

SOT363

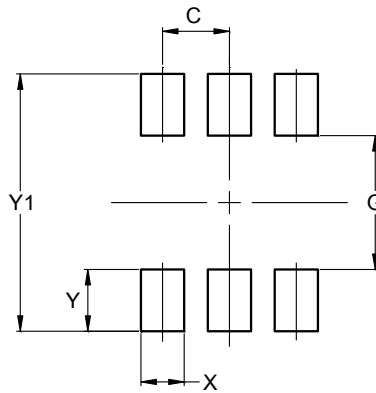

Dimensions	Value (in mm)
C	0.650
G	1.300
X	0.420
Y	0.600
Y1	2.500

X1-DFN1010-6 (Type B)

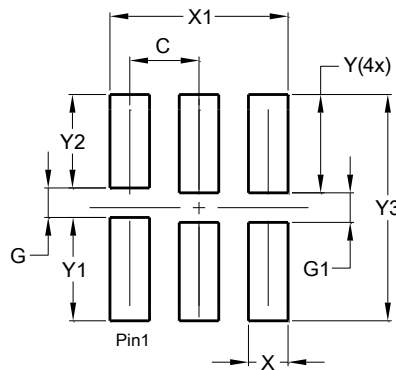

Dimensions	Value (in mm)
C	0.350
G	0.150
G1	0.150
X	0.200
X1	0.900
Y	0.500
Y1	0.525
Y2	0.475
Y3	1.150

Suggested Pad Layout (continued)

Please see <http://www.diodes.com/package-outlines.html> for the latest version.

X2-DFN1010-6

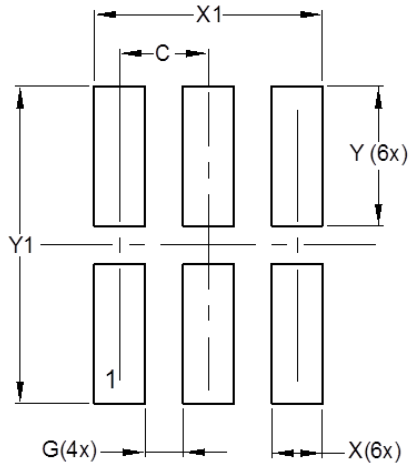

Dimensions	Value (in mm)
C	0.350
G	0.150
X	0.200
X1	0.900
Y	0.550
Y1	1.250

X2-DFN1409-6

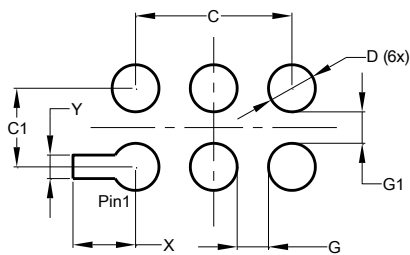

Dimensions	Value (in mm)
C	1.000
C1	0.500
D	0.300
G	0.200
G1	0.200
X	0.400
Y	0.150

X2-DFN1410-6

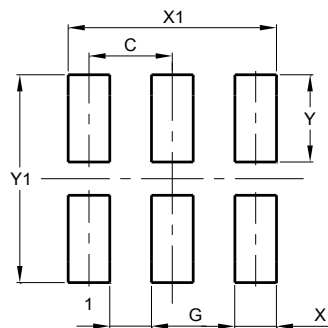

Dimensions	Value (in mm)
C	0.500
G	0.250
X	0.250
X1	1.250
Y	0.525
Y1	1.250

Mechanical Data

SOT26

- Moisture Sensitivity: Level 1 per J-STD-020
- Terminals: Finish - Matte Tin Plated Leads, Solderable per MIL-STD-202, Method 208 (e3)
- Weight: 0.016 grams (Approximate)

SOT363

- Moisture Sensitivity: Level 1 per J-STD-020
- Terminals: Finish - Matte Tin Plated Leads, Solderable per MIL-STD-202, Method 208 (e3)
- Weight: 0.006 grams (Approximate)

X1-DFN1010-6 (Type B)

- Moisture Sensitivity: Level 1 per J-STD-020
- Terminals: Finish - NiPdAu Nickel Palladium Gold, Solderable per MIL-STD-202, Method 208 (e4)
- Weight: 0.001 grams (Approximate)

X2-DFN1010-6

- Moisture Sensitivity: Level 1 per J-STD-020
- Terminals: Finish - NiPdAu Nickel Palladium Gold, Solderable per MIL-STD-202, Method 208 (e4)
- Weight: 0.001 grams (Approximate)

X2-DFN1409-6

- Moisture Sensitivity: Level 1 per J-STD-020
- Terminals: Finish - NiPdAu Nickel Palladium Gold, Solderable per MIL-STD-202, Method 208 (e4)
- Weight: 0.002 grams (Approximate)

X2-DFN1410-6

- Moisture Sensitivity: Level 1 per J-STD-020
- Terminals: Finish - NiPdAu Nickel Palladium Gold, Solderable per MIL-STD-202, Method 208 (e4)
- Weight: 0.002 grams (Approximate)

IMPORTANT NOTICE

1. DIODES INCORPORATED (Diodes) AND ITS SUBSIDIARIES MAKE NO WARRANTY OF ANY KIND, EXPRESS OR IMPLIED, WITH REGARDS TO ANY INFORMATION CONTAINED IN THIS DOCUMENT, INCLUDING, BUT NOT LIMITED TO, THE IMPLIED WARRANTIES OF MERCHANTABILITY, FITNESS FOR A PARTICULAR PURPOSE OR NON-INFRINGEMENT OF THIRD PARTY INTELLECTUAL PROPERTY RIGHTS (AND THEIR EQUIVALENTS UNDER THE LAWS OF ANY JURISDICTION).
2. The Information contained herein is for informational purpose only and is provided only to illustrate the operation of Diodes' products described herein and application examples. Diodes does not assume any liability arising out of the application or use of this document or any product described herein. This document is intended for skilled and technically trained engineering customers and users who design with Diodes' products. Diodes' products may be used to facilitate safety-related applications; however, in all instances customers and users are responsible for (a) selecting the appropriate Diodes products for their applications, (b) evaluating the suitability of Diodes' products for their intended applications, (c) ensuring their applications, which incorporate Diodes' products, comply the applicable legal and regulatory requirements as well as safety and functional-safety related standards, and (d) ensuring they design with appropriate safeguards (including testing, validation, quality control techniques, redundancy, malfunction prevention, and appropriate treatment for aging degradation) to minimize the risks associated with their applications.
3. Diodes assumes no liability for any application-related information, support, assistance or feedback that may be provided by Diodes from time to time. Any customer or user of this document or products described herein will assume all risks and liabilities associated with such use, and will hold Diodes and all companies whose products are represented herein or on Diodes' websites, harmless against all damages and liabilities.
4. Products described herein may be covered by one or more United States, international or foreign patents and pending patent applications. Product names and markings noted herein may also be covered by one or more United States, international or foreign trademarks and trademark applications. Diodes does not convey any license under any of its intellectual property rights or the rights of any third parties (including third parties whose products and services may be described in this document or on Diodes' website) under this document.
5. Diodes' products are provided subject to Diodes' Standard Terms and Conditions of Sale (<https://www.diodes.com/about/company/terms-and-conditions/terms-and-conditions-of-sales/>) or other applicable terms. This document does not alter or expand the applicable warranties provided by Diodes. Diodes does not warrant or accept any liability whatsoever in respect of any products purchased through unauthorized sales channel.
6. Diodes' products and technology may not be used for or incorporated into any products or systems whose manufacture, use or sale is prohibited under any applicable laws and regulations. Should customers or users use Diodes' products in contravention of any applicable laws or regulations, or for any unintended or unauthorized application, customers and users will (a) be solely responsible for any damages, losses or penalties arising in connection therewith or as a result thereof, and (b) indemnify and hold Diodes and its representatives and agents harmless against any and all claims, damages, expenses, and attorney fees arising out of, directly or indirectly, any claim relating to any noncompliance with the applicable laws and regulations, as well as any unintended or unauthorized application.
7. While efforts have been made to ensure the information contained in this document is accurate, complete and current, it may contain technical inaccuracies, omissions and typographical errors. Diodes does not warrant that information contained in this document is error-free and Diodes is under no obligation to update or otherwise correct this information. Notwithstanding the foregoing, Diodes reserves the right to make modifications, enhancements, improvements, corrections or other changes without further notice to this document and any product described herein. This document is written in English but may be translated into multiple languages for reference. Only the English version of this document is the final and determinative format released by Diodes.
8. Any unauthorized copying, modification, distribution, transmission, display or other use of this document (or any portion hereof) is prohibited. Diodes assumes no responsibility for any losses incurred by the customers or users or any third parties arising from any such unauthorized use.
9. This Notice may be periodically updated with the most recent version available at <https://www.diodes.com/about/company/terms-and-conditions/important-notice>

The Diodes logo is a registered trademark of Diodes Incorporated in the United States and other countries.
All other trademarks are the property of their respective owners.
© 2023 Diodes Incorporated. All Rights Reserved.

www.diodes.com

Looking for pricing, stock, or lifecycle information?

Click below to explore more details on WIN SOURCE:

 [View 74LVC2G14W6-7 on WIN SOURCE](#)

 [Diodes Incorporated Information](#)

Optimize Your Supply Chain with WIN SOURCE Solutions

-  Global Sourcing Solution
-  Obsolete Management
-  Cost Control Management
-  Shortage Management
-  Alternative Solution
-  Excess Inventory Management