



**THE DATASHEET OF  
TC7662BEOA713**



## CHARGE PUMP DC-TO-DC VOLTAGE CONVERTER

### FEATURES

- Wide Operating Voltage Range: 1.5V to 15V
- Boost Pin (Pin 1) for Higher Switching Frequency
- High Power Efficiency is 96%
- Easy to Use – Requires Only 2 External Non-Critical Passive Components
- Improved Direct Replacement for Industry Standard ICL7660 and Other Second Source Devices

### APPLICATIONS

- Simple Conversion of +5V to  $\pm 5V$  Supplies
- Voltage Multiplication  $V_{OUT} = \pm nV_{IN}$
- Negative Supplies for Data Acquisition Systems and Instrumentation
- RS232 Power Supplies
- Supply Splitter,  $V_{OUT} = \pm V_S/2$

### PIN CONFIGURATION (DIP AND SOIC)

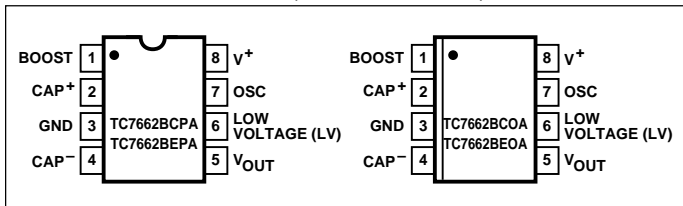

### GENERAL DESCRIPTION

The TC7662B is a pin-compatible upgrade to the Industry standard TC7660 charge pump voltage converter. It converts a +1.5V to +15V input to a corresponding – 1.5 to – 15V output using only two low-cost capacitors, eliminating inductors and their associated cost, size and EMI.

The on-board oscillator operates at a nominal frequency of 10kHz. Frequency is increased to 35kHz when pin 1 is connected to V<sup>+</sup>, allowing the use of smaller external capacitors. Operation below 10kHz (for lower supply current applications) is also possible by connecting an external capacitor from OSC to ground (with pin 1 open).

The TC7662B is available in both 8-pin DIP and 8-pin small outline (SO) packages in commercial and extended temperature ranges.

### ORDERING INFORMATION

Part No.	Package	Temperature Range
TC7662BCOA	8-Pin SOIC	0°C to +70°C
TC7662BCPA	8-Pin Plastic DIP	0°C to +70°C
TC7662BEOA	8-Pin SOIC	– 40°C to +85°C
TC7662BEPA	8-Pin Plastic DIP	– 40°C to +85°C
<b>TC7660EV</b>	<b>Evaluation Kit for Charge Pump Family</b>	

### FUNCTIONAL BLOCK DIAGRAM

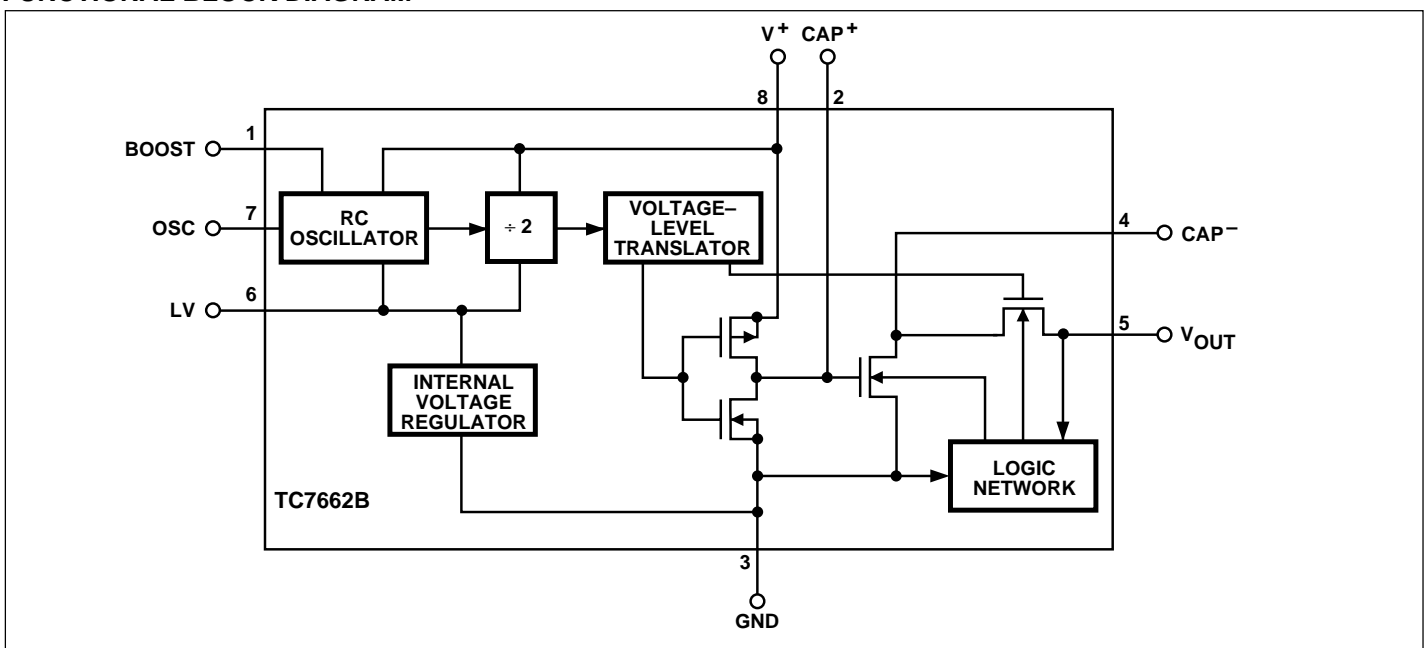

# CHARGE PUMP DC-TO-DC VOLTAGE CONVERTER

## TC7662B

### ABSOLUTE MAXIMUM RATINGS\*

Supply Voltage .....	+16.5V
LV, Boost and OSC Inputs Voltage (Note 1)	
$V^+ < 5.5V$ .....	- 0.3V to ( $V^+ + 0.3V$ )
$> 5.5V$ .....	( $V^+ - 5.5V$ ) to ( $V^+ + 0.3V$ )
Current Into LV (Note 1)	
$V^+ > 3.5V$ .....	20 $\mu$ A
Output Short Duration	
( $V_{SUPPLY} \leq 5.5V$ ) .....	Continuous
Power Dissipation ( $T_A \leq 70^\circ C$ ) (Note 2)	
Plastic DIP .....	730mW
SO .....	470mW

### Operating Temperature Range

C Suffix .....	0 $^\circ$ C to +70 $^\circ$ C
E Suffix .....	- 40 $^\circ$ C to +85 $^\circ$ C
Storage Temperature Range .....	- 65 $^\circ$ C to +150 $^\circ$ C
Lead Temperature (Soldering, 10 sec) .....	+300 $^\circ$ C

\* Static-sensitive device. Unused devices must be stored in conductive material. Protect devices from static discharge and static fields. Stresses above those listed under "Absolute Maximum Ratings" may cause permanent damage to the device. These are stress ratings only and functional operation of the device at these or any other conditions above those indicated in the operation sections of the specifications is not implied. Exposure to absolute maximum rating conditions for extended periods may affect device reliability.

### ELECTRICAL CHARACTERISTICS: $V^+ = 5V$ , $T_A = +25^\circ C$ , OSC = Free running, Test Circuit Figure 2, Unless Otherwise Specified.

Symbol	Parameter	Test Conditions	Min	Typ	Max	Unit
$I^+$	Supply Current (Note 3) (Boost pin OPEN OR GND)	$R_L = \infty$ , +25 $^\circ$ C	—	80	160	$\mu$ A
		0 $^\circ$ C $\leq T_A \leq$ +70 $^\circ$ C	—	—	180	$\mu$ A
		- 40 $^\circ$ C $\leq T_A \leq$ +85 $^\circ$ C	—	—	180	$\mu$ A
		- 55 $^\circ$ C $\leq T_A \leq$ +125 $^\circ$ C	—	—	200	$\mu$ A
$I^+$	Supply Current (Boost pin = $V^+$ )	0 $^\circ$ C $\leq T_A \leq$ +70 $^\circ$ C	—	—	300	$\mu$ A
		- 40 $^\circ$ C $\leq T_A \leq$ +85 $^\circ$ C	—	—	350	
		- 55 $^\circ$ C $\leq T_A \leq$ +125 $^\circ$ C	—	—	400	
$V_H^+$	Supply Voltage Range, High (Note 4)	$R_L = 10$ k $\Omega$ , LV Open, $T_{MIN} \leq T_A \leq T_{MAX}$	3.0	—	15	V
$V_L^+$	Supply Voltage Range, Low	$R_L = 10$ k $\Omega$ , LV to GND, $T_{MIN} \leq T_A \leq T_{MAX}$	1.5	—	3.5	V
$R_{OUT}$	Output Source Resistance	$I_{OUT} = 20$ mA, 0 $^\circ$ C $\leq T_A \leq$ +70 $^\circ$ C	—	65	100	$\Omega$
		$I_{OUT} = 20$ mA, - 40 $^\circ$ C $\leq T_A \leq$ +85 $^\circ$ C	—	—	120	$\Omega$
		$I_{OUT} = 20$ mA, - 55 $^\circ$ C $\leq T_A \leq$ +125 $^\circ$ C	—	—	150	$\Omega$
		$I_{OUT} = 3$ mA, $V^+ = 2V$ , LV to GND , 0 $^\circ$ C $\leq T_A \leq$ +70 $^\circ$ C	—	—	250	$\Omega$
		$I_{OUT} = 3$ mA, $V^+ = 2V$ , LV to GND , - 40 $^\circ$ C $\leq T_A \leq$ +85 $^\circ$ C	—	—	300	$\Omega$
$f_{OSC}$	Oscillator Frequency	$C_{OSC} = 0$ , Pin 1 Open or GND Pin 1 = $V^+$	5	10 35	—	kHz
$P_{Eff}$	Power Efficiency	$R_L = 5$ k $\Omega$	96	96	—	%
		$T_{MIN} \leq T_A \leq T_{MAX}$	95	97	—	
$V_{OUTEff}$	Voltage Conversion Efficiency	$R_L = \infty$	99	99.9	—	%
$Z_{OSC}$	Oscillator Impedance	$V^+ = 2V$	—	1	—	M $\Omega$
		$V^+ = 5V$	—	100	—	k $\Omega$

### NOTES:

1. Connecting any terminal to voltages greater than  $V^+$  or less than GND may cause destructive latch-up. It is recommended that no inputs from sources operating from external supplies be applied prior to "power up" of the TC7662B.
2. Derate linearly above 50 $^\circ$ C by 5.5 mW/ $^\circ$ C.
3. In the test circuit, there is no external capacitor applied to pin 7. However, when the device is plugged into a test socket, there is usually a very small but finite stray capacitance present, of the order of 5pF.
4. The TC7662B can operate without an external diode over the full temperature and voltage range. This device will function in existing designs which incorporate an external diode with no degradation in overall circuit performance.

# CHARGE PUMP DC-TO-DC VOLTAGE CONVERTER

TC7662B

## DETAILED DESCRIPTION

The TC7662B contains all the necessary circuitry to complete a negative voltage converter, with the exception of two external capacitors which may be inexpensive 1 $\mu$ F polarized electrolytic types. The mode of operation of the device may be best understood by considering Figure 2, which shows an idealized negative voltage converter. Capacitor C<sub>1</sub> is charged to a voltage V<sup>+</sup> for the half cycle when switches S<sub>1</sub> and S<sub>3</sub> are closed. (Note: Switches S<sub>2</sub> and S<sub>4</sub> are open during this half cycle.) During the second half cycle of operation, switches S<sub>2</sub> and S<sub>4</sub> are closed, with S<sub>1</sub> and S<sub>3</sub> open, thereby shifting capacitor C<sub>1</sub> negatively by V<sup>+</sup> volts. Charge is then transferred from C<sub>1</sub> to C<sub>2</sub> such that the voltage on C<sub>2</sub> is exactly V<sup>+</sup>, assuming ideal switches and no load on C<sub>2</sub>. The TC7662B approaches this ideal situation more closely than existing non-mechanical circuits.

In the TC7662B, the four switches of Figure 2 are MOS power switches; S<sub>1</sub> is a P-channel device and S<sub>2</sub>, S<sub>3</sub> and S<sub>4</sub> are N-channel devices. The main difficulty with this approach is that in integrating the switches, the substrates of S<sub>3</sub> and S<sub>4</sub> must always remain reverse biased with respect to their sources, but not so much as to degrade their "ON" resistances. In addition, at circuit start up, and under output short circuit conditions (V<sub>OUT</sub> = V<sup>+</sup>), the output voltage must be sensed and the substrate bias adjusted accordingly. Failure to accomplish this would result in high power losses and probable device latchup.

The problem is eliminated in the TC7662B by a logic network which senses the output voltage (V<sub>OUT</sub>) together with the level translators, and switches the substrates of S<sub>3</sub> and S<sub>4</sub> to the correct level to maintain necessary reverse bias.

The voltage regulator portion of the TC7662B is an integral part of the anti-latchup circuitry; however, its inherent voltage drop can degrade operation at low voltages. Therefore, to improve low voltage operation, the "LV" pin should be connected to GND, disabling the regulator. For supply voltages greater than 3.5 volts, the LV terminal must be left open to insure latchup proof operation and prevent device damage.

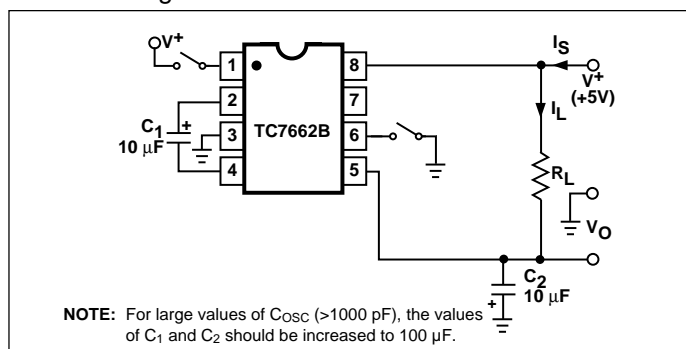

Figure 1. TC7662B Test Circuit

## THEORETICAL POWER EFFICIENCY CONSIDERATIONS

In theory, a voltage converter can approach 100% efficiency if certain conditions are met:

- The drive circuitry consumes minimal power.
- The output switches have extremely low ON resistance and virtually no offset.
- The impedances of the pump and reservoir capacitors are negligible at the pump frequency.

The TC7662B approaches these conditions for negative voltage conversion if large values of C<sub>1</sub> and C<sub>2</sub> are used. **Energy is lost only in the transfer of charge between capacitors if a change in voltage occurs.** The energy lost is defined by:

$$E = 1/2 C_1 (V_1^2 - V_2^2)$$

where V<sub>1</sub> and V<sub>2</sub> are the voltages on C<sub>1</sub> during the pump and transfer cycles. If the impedances of C<sub>1</sub> and C<sub>2</sub> are relatively high at the pump frequency (refer to Figure 2) compared to the value of R<sub>L</sub>, there will be a substantial difference in voltages V<sub>1</sub> and V<sub>2</sub>. Therefore, it is desirable not only to make C<sub>2</sub> as large as possible to eliminate output voltage ripple, but also to employ a correspondingly large value for C<sub>1</sub> in order to achieve maximum efficiency of operation.

## Dos and Don'ts

- Do not exceed maximum supply voltages.
- Do not connect the LV terminal to GND for supply voltages greater than 3.5 volts.
- Do not short circuit the output to V<sup>+</sup> supply for voltages above 5.5 volts for extended periods; however, transient conditions including start-up are okay.

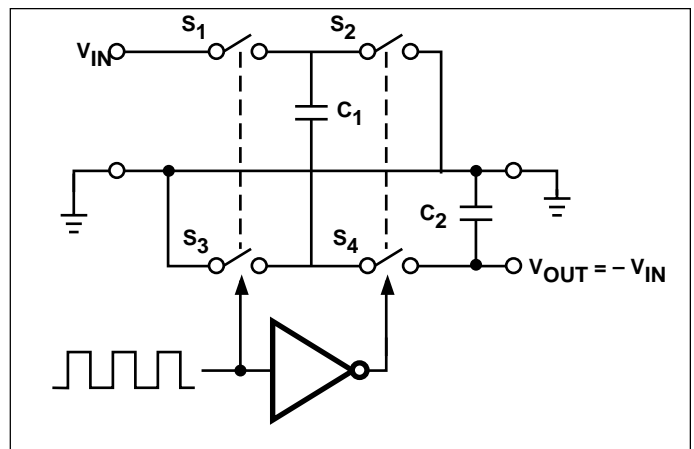

Figure 2. Idealized Negative Voltage Capacitor

## TC7662B

- When using polarized capacitors in the inverting mode, the + terminal of  $C_1$  must be connected to pin 2 of the TC7662B and the - terminal of  $C_2$  must be connected to GND.
- If the voltage supply driving the TC7662B has a large source impedance (25-30 ohms), then a  $2.2\mu\text{F}$  capacitor from pin 8 to ground may be required to limit the rate of rise of the input voltage to less than  $2\text{V}/\mu\text{sec}$ .

## TYPICAL APPLICATIONS

### Simple Negative Voltage Converter

The majority of applications will undoubtedly utilize the TC7662B for generation of negative supply voltages. Figure 3 shows typical connections to provide a negative supply where a positive supply of +1.5V to +15V is available. Keep in mind that pin 6 (LV) is tied to the supply negative (GND) for supply voltages below 3.5 volts.

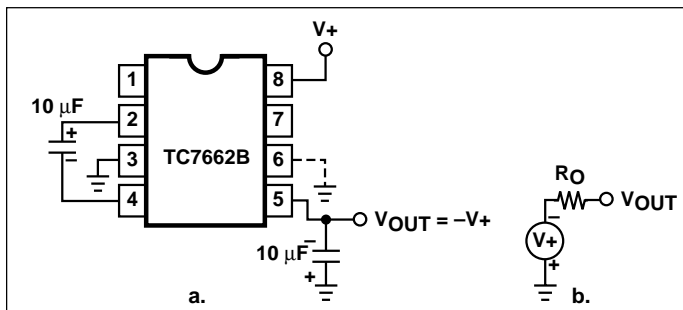

Figure 3. Simple Negative Converter and its Output Equivalent

The output characteristics of the circuit in Figure 3 can be approximated by an ideal voltage source in series with a resistance as shown in Figure 3b. The voltage source has a value of  $-(V_+)$ . The output impedance ( $R_O$ ) is a function of the ON resistance of the internal MOS switches (shown in Figure 2), the switching frequency, the value of  $C_1$  and  $C_2$ , and the ESR (equivalent series resistance) of  $C_1$  and  $C_2$ . A good first order approximation for  $R_O$  is:

$$R_O \cong 2(R_{SW1} + R_{SW3} + ESR_{C1}) + 2(R_{SW2} + R_{SW4} + ESR_{C1}) + \frac{1}{f_{PUMP} \times C_1} + ESR_{C2}$$

$$(f_{PUMP} = \frac{f_{OSC}}{2}, R_{SWX} = \text{MOSFET switch resistance})$$

Combining the four  $R_{SWX}$  terms as  $R_{SW}$ , we see that:

$$R_O \cong 2 \times R_{SW} + \frac{1}{f_{PUMP} \times C_1} + 4 \times ESR_{C1} + ESR_{C2} \Omega$$

$R_{SW}$ , the total switch resistance, is a function of supply

voltage and temperature (See the Output Source Resistance graphs), typically  $23\Omega$  at  $+25^\circ\text{C}$  and 5V. Careful selection of  $C_1$  and  $C_2$  will reduce the remaining terms, minimizing the output impedance. High value capacitors will reduce the  $1/(f_{PUMP} \times C_1)$  component, and low ESR capacitors will lower the ESR term. Increasing the oscillator frequency will reduce the  $1/(f_{PUMP} \times C_1)$  term, but may have the side effect of a net increase in output impedance when  $C_1 > 10\mu\text{F}$  and there is not enough time to fully charge the capacitors every cycle. In a typical application when  $f_{OSC} = 10\text{kHz}$  and  $C = C_1 = C_2 = 10\mu\text{F}$ :

$$R_O \cong 2 \times 23 + \frac{1}{(5 \times 10^3 \times 10 \times 10^{-6})} + 4 \times ESR_{C1} + ESR_{C2}$$

$$R_O \cong (46 + 20 + 5 \times ESR_C) \Omega$$

Since the ESRs of the capacitors are reflected in the output impedance multiplied by a factor of 5, a high value could potentially swamp out a low  $1/(f_{PUMP} \times C_1)$  term, rendering an increase in switching frequency or filter capacitance ineffective. Typical electrolytic capacitors may have ESRs as high as  $10\Omega$ .

### Output Ripple

ESR also affects the ripple voltage seen at the output. The total ripple is determined by 2 voltages, A and B, as shown in Figure 4. Segment A is the voltage drop across the ESR of  $C_2$  at the instant it goes from being charged by  $C_1$  (current flowing into  $C_2$ ) to being discharged through the load (current flowing out of  $C_2$ ). The magnitude of this current change is  $2 \times I_{OUT}$ , hence the total drop is  $2 \times I_{OUT} \times ESR_{C2}$  volts. Segment B is the voltage change across  $C_2$  during time  $t_2$ , the half of the cycle when  $C_2$  supplies current to the load. The drop at B is  $I_{OUT} \times t_2 / C_2$  volts. The peak-to-peak ripple voltage is the sum of these voltage drops:

$$V_{RIPPLE} \cong \left( \frac{1}{2 \times f_{PUMP} \times C_2} + ESR_{C2} \times I_{OUT} \right)$$

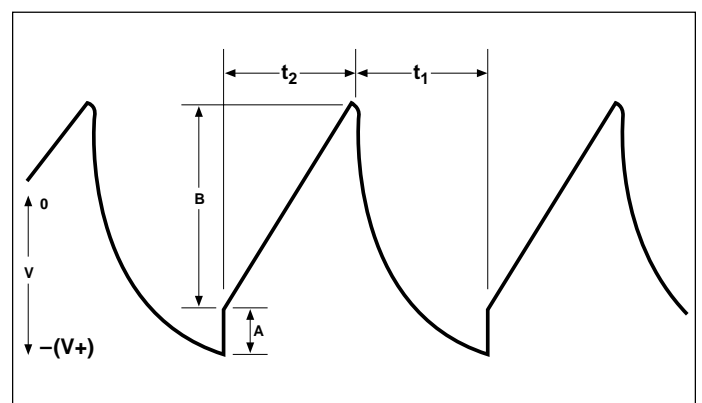

Figure 4. Output Ripple

# CHARGE PUMP DC-TO-DC VOLTAGE CONVERTER

TC7662B

## Paralleling Devices

Any number of TC7662B voltage converters may be paralleled to reduce output resistance (Figure 5). The reservoir capacitor,  $C_2$ , serves all devices, while each device requires its own pump capacitor,  $C_1$ . The resultant output resistance would be approximately:

$$R_{OUT} = \frac{R_{OUT} \text{ (of TC7662B)}}{n \text{ (number of devices)}}$$

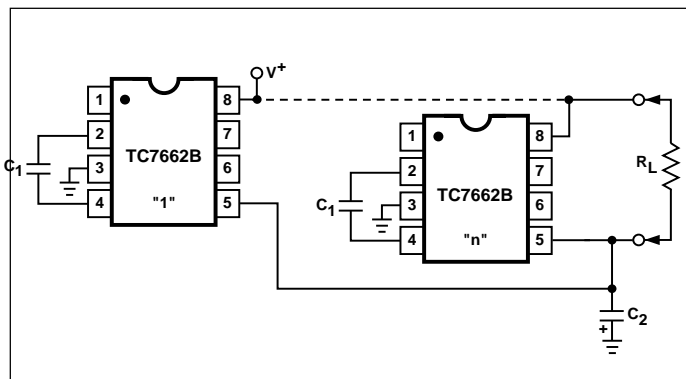

Figure 5. Paralleling Devices

## Cascading Devices

The TC7662B may be cascaded as shown to produce larger negative multiplication of the initial supply voltage. However, due to the finite efficiency of each device, the practical limit is 10 devices for light loads. The output voltage is defined by:

$$V_{OUT} = -n(V_{IN})$$

where  $n$  is an integer representing the number of devices cascaded. The resulting output resistance would be approximately the weighted sum of the individual TC7662B  $R_{OUT}$  values.

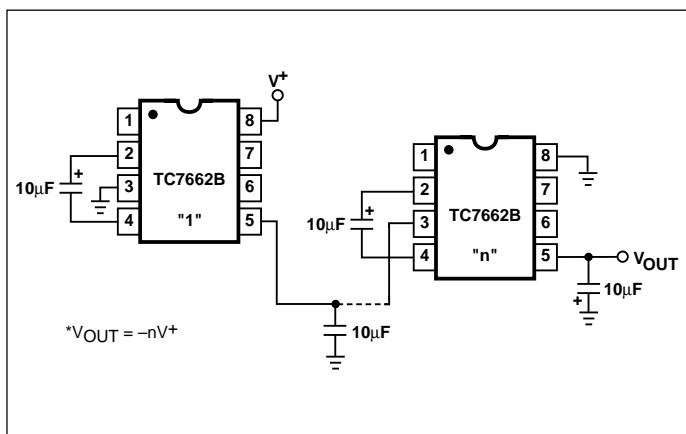

Figure 6. Cascading Devices for Increased Output Voltage

## Changing the TC7662B Oscillator Frequency

It may be desirable in some applications (due to noise or other considerations) to increase the oscillator frequency. This is achieved by one of several methods described below:

By connecting the BOOSTPin (Pin 1) to  $V^+$ , the oscillator charge and discharge current is increased and, hence the oscillator frequency is increased by approximately 3-1/2 times. The result is a decrease in the output impedance and ripple. This is of major importance for surface mount applications where capacitor size and cost are critical. Smaller capacitors, e.g.,  $0.1\mu\text{F}$ , can be used in conjunction with the Boost Pin in order to achieve similar output currents compared to the device free running with  $C_1 = C_2 = 1\mu\text{F}$  or  $10\mu\text{F}$ . (Refer to graph of Output Source Resistance as a Function of Oscillator Frequency).

Increasing the oscillator frequency can also be achieved by overdriving the oscillator from an external clock as shown in Figure 7. In order to prevent device latchup, a  $1\text{k}\Omega$  resistor must be used in series with the clock output. In a situation where the designer has generated the external clock frequency using TTL logic, the addition of a  $10\text{k}\Omega$  pullup resistor to  $V^+$  supply is required. Note that the pump frequency with external clocking, as with internal clocking, will be 1/2 of the clock frequency. Output transitions occur on the positive-going edge of the clock.

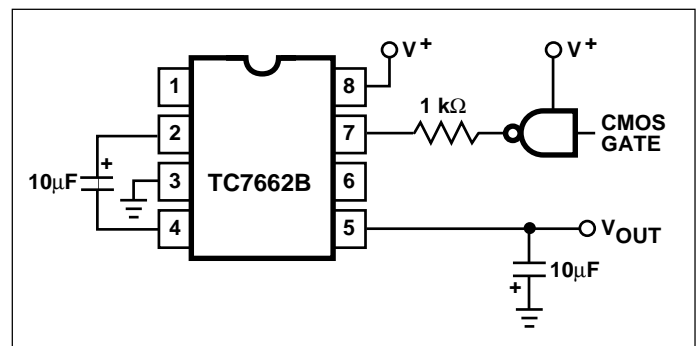

Figure 7. External Clocking

It is also possible to increase the conversion efficiency of the TC7662B at low load levels by lowering the oscillator frequency. This reduces the switching losses, and is shown in Figure 8. However, lowering the oscillator frequency will cause an undesirable increase in the impedance of the pump ( $C_1$ ) and reservoir ( $C_2$ ) capacitors; this is overcome by increasing the values of  $C_1$  and  $C_2$  by the same factor that the frequency has been reduced. For example, the addition of a  $100\text{pF}$  capacitor between pin 7 (Osc) and  $V^+$  will lower the oscillator frequency to  $1\text{kHz}$  from its nominal frequency of  $10\text{kHz}$  (multiple of 10), and thereby necessitate a corresponding increase in the value of  $C_1$  and  $C_2$  (from  $10\mu\text{F}$  to  $100\mu\text{F}$ ).

## TC7662B

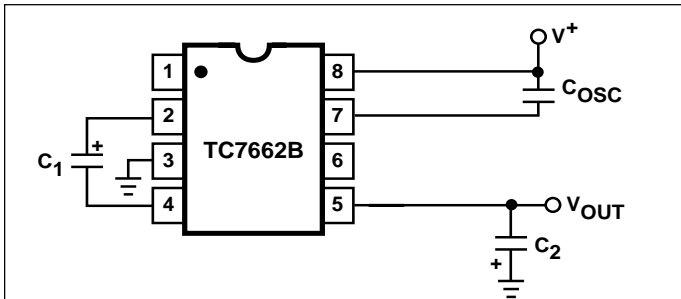

Figure 8. Lowering Oscillator Frequency

### Positive Voltage Doubling

The TC7662B may be employed to achieve positive voltage doubling using the circuit shown in Figure 9. In this application, the pump inverter switches of the TC7662B are used to charge  $C_1$  to a voltage level of  $V^+ - V_F$  (where  $V^+$  is the supply voltage and  $V_F$  is the forward voltage on  $C_1$  plus the supply voltage ( $V^+$ ) applied through diode  $D_2$  to capacitor  $C_2$ ). The voltage thus created on  $C_2$  becomes  $(2V^+) - (2V_F)$ , or twice the supply voltage minus the combined forward voltage drops of diodes  $D_1$  and  $D_2$ .

The source impedance of the output ( $V_{OUT}$ ) will depend on the output current, but for  $V^+ = 5V$  and an output current of 10 mA, it will be approximately  $60\Omega$ .

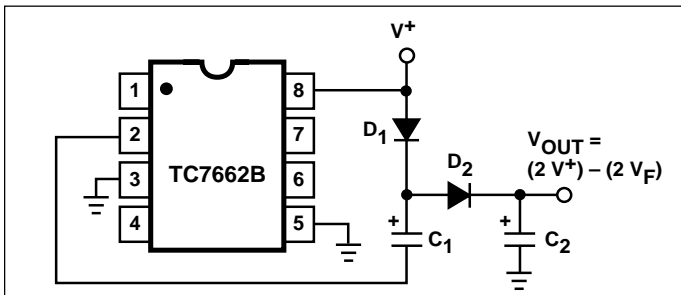

Figure 9. Positive Voltage Multiplier

### Combined Negative Voltage Conversion and Positive Supply Multiplication

Figure 10 combines the functions shown in Figures 3 and 9 to provide negative voltage conversion and positive voltage doubling simultaneously. This approach would be, for example, suitable for generating +9V and -5V from an existing +5V supply. In this instance, capacitors  $C_1$  and  $C_3$  perform the pump and reservoir functions, respectively, for the generation of the negative voltage, while capacitors  $C_2$  and  $C_4$  are pump and reservoir, respectively, for the doubled positive voltage. There is a penalty in this configuration which combines both functions, however, in that the source impedances of the generated supplies will be somewhat higher due to the finite impedance of the common charge pump driver at pin 2 of the device.

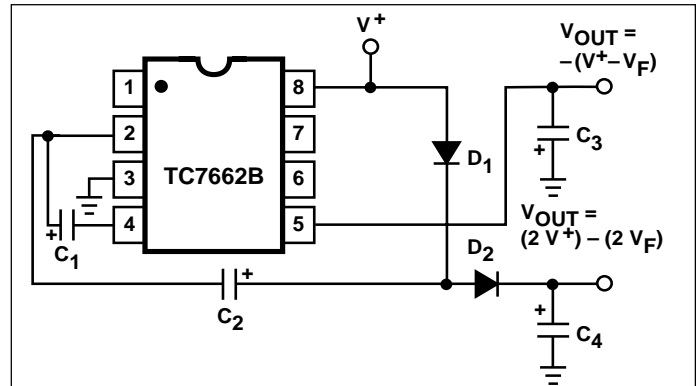

Figure 10. Combined Negative Converter and Positive Doubler

### Voltage Splitting

The bidirectional characteristics can also be used to split a higher supply in half, as shown in Figure 11. The combined load will be evenly shared between the two sides and a high value resistor to the LV pin ensures start-up. Because the switches share the load in parallel, the output impedance is much lower than in the standard circuits, and higher currents can be drawn from the device. By using this circuit, and then the circuit of Figure 6, +15V can be converted (via +7.5V and -7.5V) to a nominal -15V, though with rather high series resistance ( $\sim 250\Omega$ ).

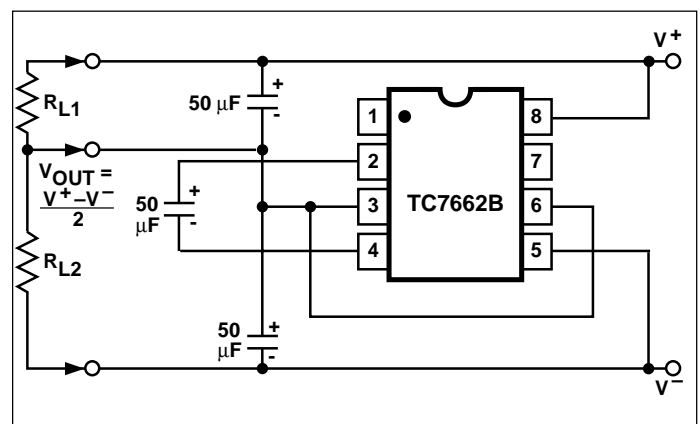

Figure 11. Splitting a Supply in Half

# CHARGE PUMP DC-TO-DC VOLTAGE CONVERTER

TC7662B

## Regulated Negative Voltage Supply

In some cases, the output impedance of the TC7662B can be a problem, particularly if the load current varies substantially. The circuit of Figure 12 can be used to overcome this by controlling the input voltage, via an ICL7611 low-power CMOS op amp, in such a way as to maintain a nearly constant output voltage. Direct feedback is advisable, since the TC7662B's output does not respond instantaneously to change in input, but only after the switching delay. The circuit shown supplies enough delay to accommodate the TC7662B, while maintaining adequate feedback. An increase in pump and storage capacitors is desirable, and the values shown provide an output impedance of less than  $5\Omega$  to a load of 10mA.

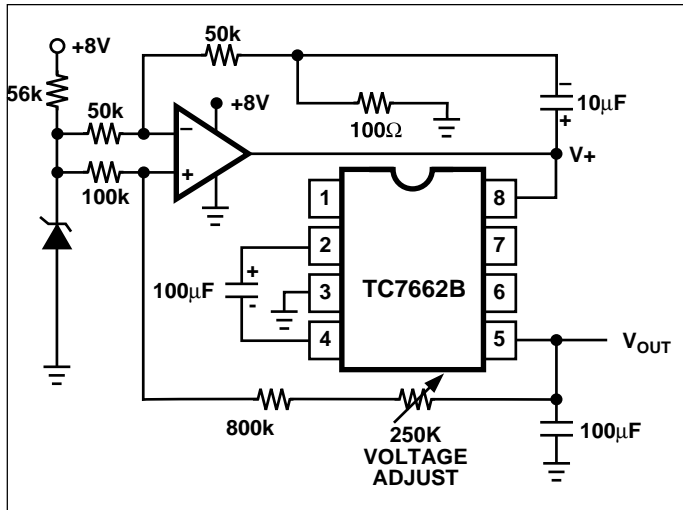

Figure 12. Regulating the Output Voltage

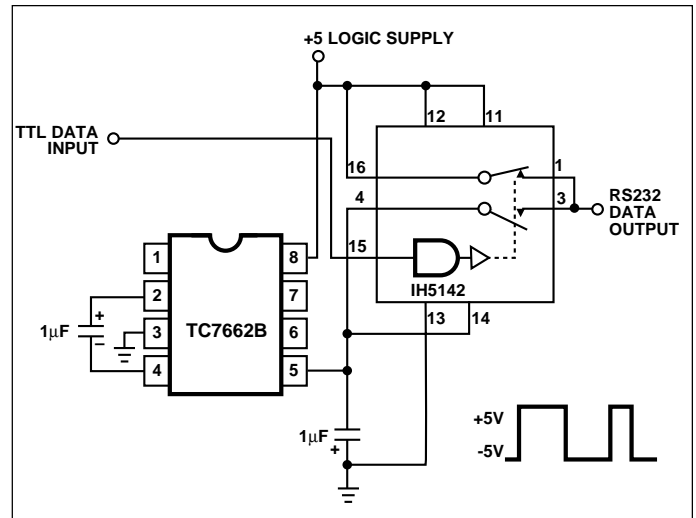

Figure 13. RS232 Levels from a Single 5V Supply

# CHARGE PUMP DC-TO-DC VOLTAGE CONVERTER

## TC7662B

### TYPICAL CHARACTERISTICS

**Supply Current vs. Temperature (with Boost Pin =  $V_{IN}$ )**

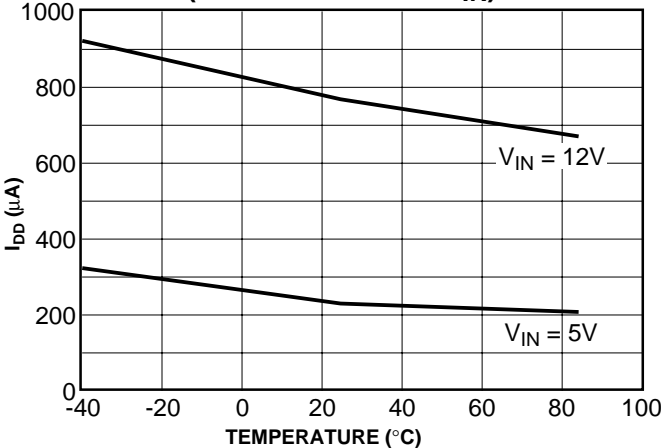

**Voltage Conversion**

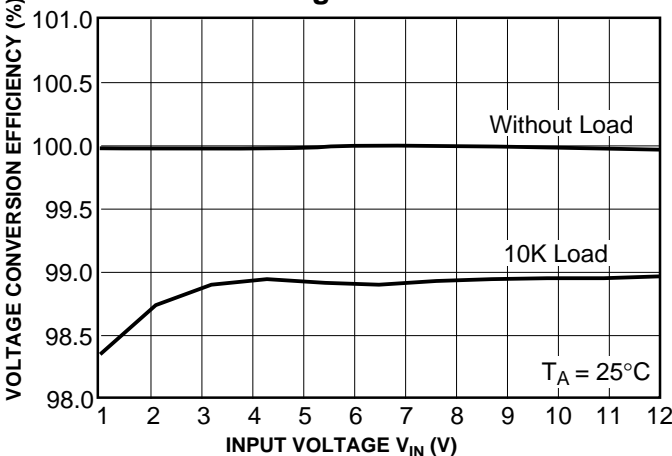

**Output Source Resistance vs. Supply Voltage**

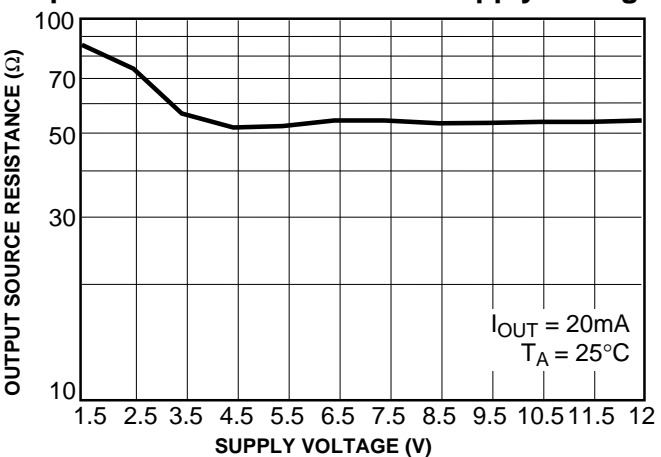

**Output Source Resistance vs. Temperature**

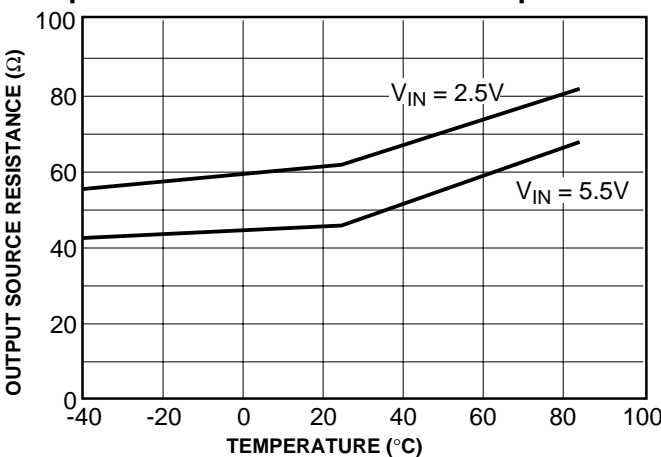

**Output Voltage vs. Output Current**

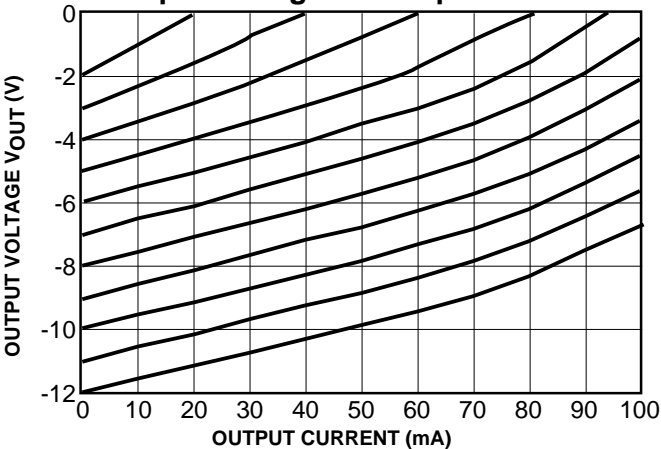

**Supply Current vs. Temperature**

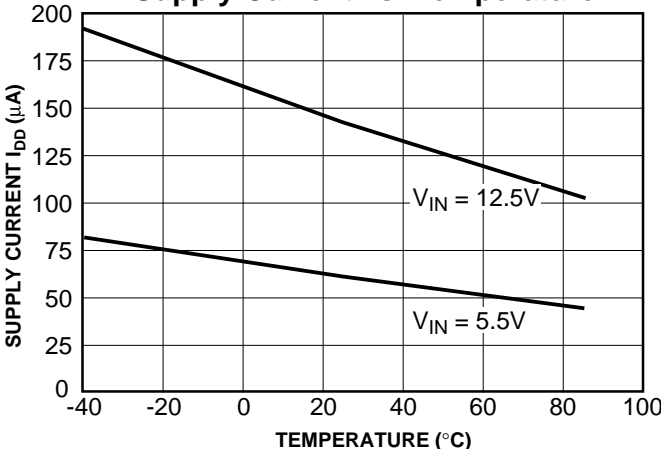

# CHARGE PUMP DC-TO-DC VOLTAGE CONVERTER

TC7662B

## TYPICAL CHARACTERISTICS (cont.)

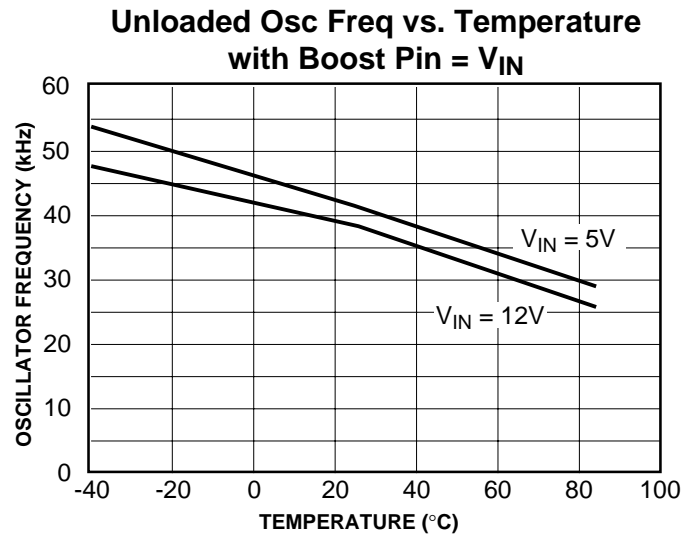
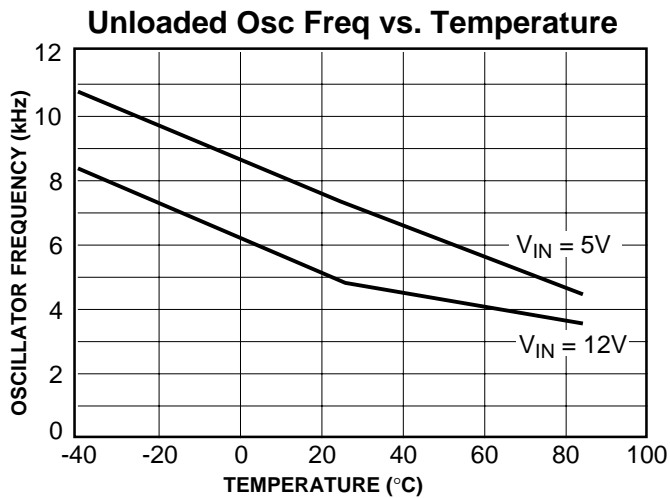

## PACKAGE DIMENSIONS

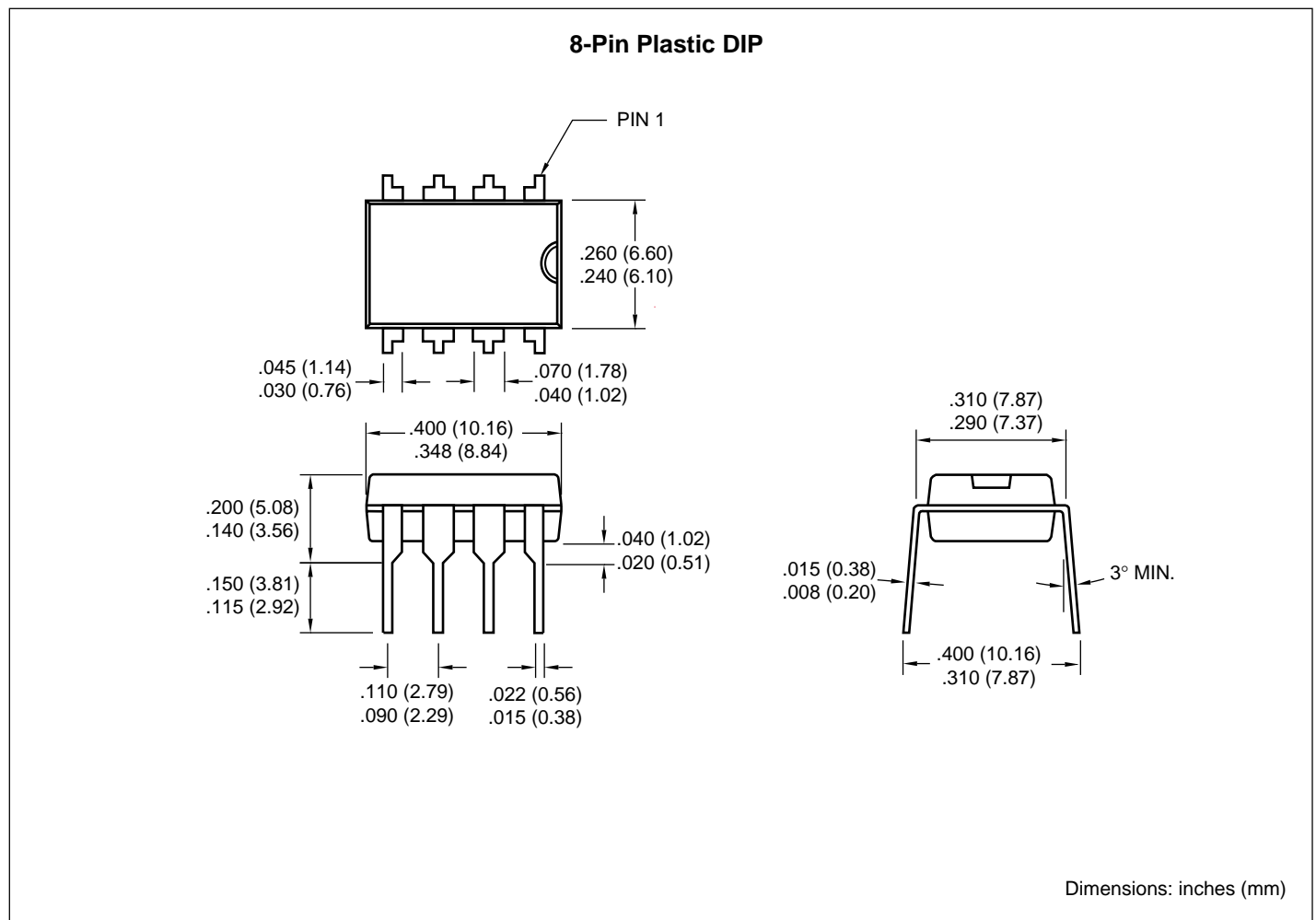

# CHARGE PUMP DC-TO-DC VOLTAGE CONVERTER

## TC7662B

### PACKAGE DIMENSIONS (Cont.)

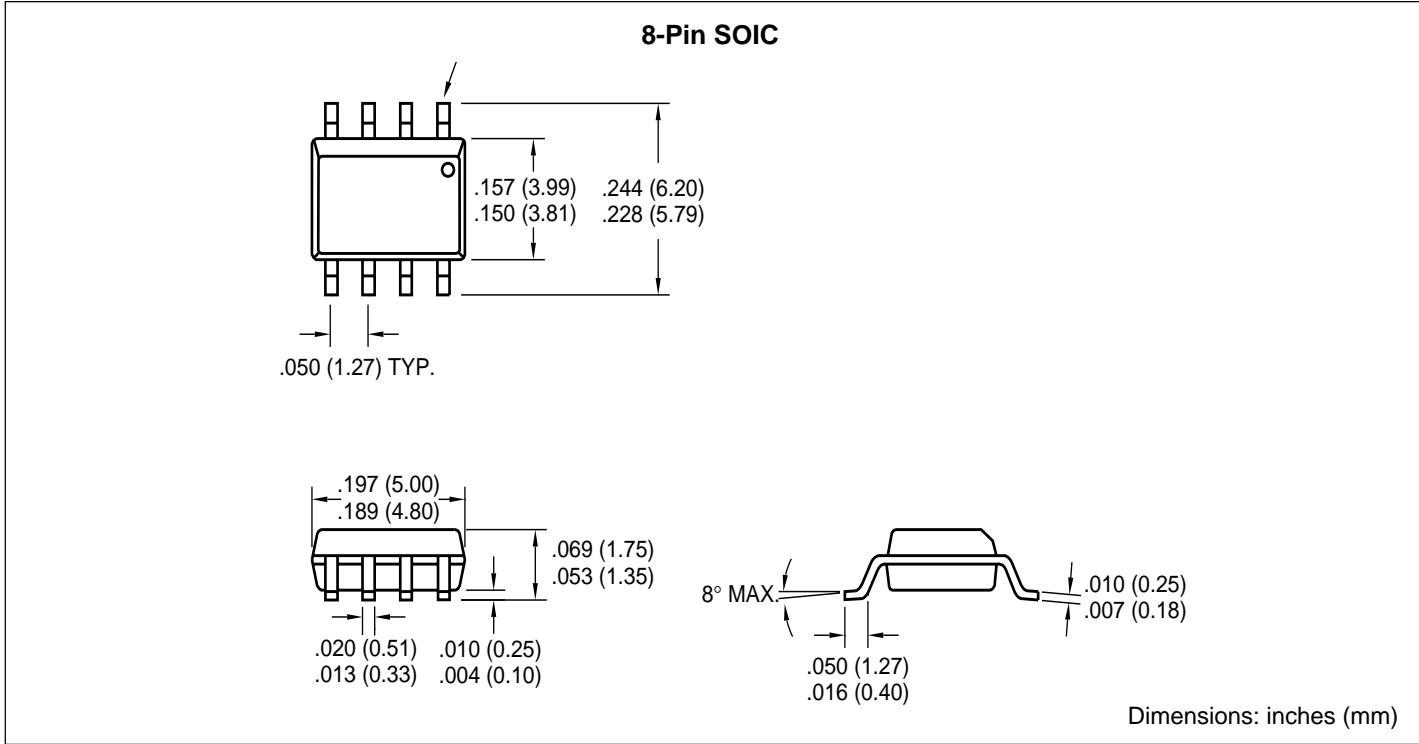



## WORLDWIDE SALES AND SERVICE

### AMERICAS

#### Corporate Office

2355 West Chandler Blvd.  
Chandler, AZ 85224-6199  
Tel: 480-792-7200 Fax: 480-792-7277  
Technical Support: 480-792-7627  
Web Address: <http://www.microchip.com>

#### Rocky Mountain

2355 West Chandler Blvd.  
Chandler, AZ 85224-6199  
Tel: 480-792-7966 Fax: 480-792-7456

#### Atlanta

500 Sugar Mill Road, Suite 200B  
Atlanta, GA 30350  
Tel: 770-640-0034 Fax: 770-640-0307

#### Austin

Analog Product Sales  
8303 MoPac Expressway North  
Suite A-201  
Austin, TX 78759  
Tel: 512-345-2030 Fax: 512-345-6085

#### Boston

2 Lan Drive, Suite 120  
Westford, MA 01886  
Tel: 978-692-3848 Fax: 978-692-3821

#### Boston

Analog Product Sales  
Unit A-8-1 Millbrook Tarry Condominium  
97 Lowell Road  
Concord, MA 01742  
Tel: 978-371-6400 Fax: 978-371-0050

#### Chicago

333 Pierce Road, Suite 180  
Itasca, IL 60143  
Tel: 630-285-0071 Fax: 630-285-0075

#### Dallas

4570 Westgrove Drive, Suite 160  
Addison, TX 75001  
Tel: 972-818-7423 Fax: 972-818-2924

#### Dayton

Two Prestige Place, Suite 130  
Miamisburg, OH 45342  
Tel: 937-291-1654 Fax: 937-291-9175

#### Detroit

Tri-Atria Office Building  
32255 Northwestern Highway, Suite 190  
Farmington Hills, MI 48334  
Tel: 248-538-2250 Fax: 248-538-2260

#### Los Angeles

18201 Von Karman, Suite 1090  
Irvine, CA 92612  
Tel: 949-263-1888 Fax: 949-263-1338

#### Mountain View

Analog Product Sales  
1300 Terra Bella Avenue  
Mountain View, CA 94043-1836  
Tel: 650-968-9241 Fax: 650-967-1590

#### New York

150 Motor Parkway, Suite 202  
Hauppauge, NY 11788  
Tel: 631-273-5305 Fax: 631-273-5335

#### San Jose

Microchip Technology Inc.  
2107 North First Street, Suite 590  
San Jose, CA 95131  
Tel: 408-436-7950 Fax: 408-436-7955

#### Toronto

6285 Northam Drive, Suite 108  
Mississauga, Ontario L4V 1X5, Canada  
Tel: 905-673-0699 Fax: 905-673-6509

### ASIA/PACIFIC

#### China - Beijing

Microchip Technology Beijing Office  
Unit 915  
New China Hong Kong Manhattan Bldg.  
No. 6 Chaoyangmen Beidajie  
Beijing, 100027, No. China  
Tel: 86-10-85282100 Fax: 86-10-85282104

#### China - Shanghai

Microchip Technology Shanghai Office  
Room 701, Bldg. B  
Far East International Plaza  
No. 317 Xian Xia Road  
Shanghai, 200051  
Tel: 86-21-6275-5700 Fax: 86-21-6275-5060

#### Hong Kong

Microchip Asia Pacific  
RM 2101, Tower 2, Metroplaza  
223 Hing Fong Road  
Kwai Fong, N.T., Hong Kong  
Tel: 852-2401-1200 Fax: 852-2401-3431

#### India

Microchip Technology Inc.  
India Liaison Office  
Divyasree Chambers  
1 Floor, Wing A (A3/A4)  
No. 11, OIShaughnessey Road  
Bangalore, 560 025, India  
Tel: 91-80-2290061 Fax: 91-80-2290062

#### Japan

Microchip Technology Intl. Inc.  
Benex S-1 6F  
3-18-20, Shinyokohama  
Kohoku-Ku, Yokohama-shi  
Kanagawa, 222-0033, Japan  
Tel: 81-45-471-6166 Fax: 81-45-471-6122

#### Korea

Microchip Technology Korea  
168-1, Youngbo Bldg. 3 Floor  
Samsung-Dong, Kangnam-Ku  
Seoul, Korea  
Tel: 82-2-554-7200 Fax: 82-2-558-5934

### ASIA/PACIFIC (continued)

#### Singapore

Microchip Technology Singapore Pte Ltd.  
200 Middle Road  
#07-02 Prime Centre  
Singapore, 188980  
Tel: 65-334-8870 Fax: 65-334-8850

#### Taiwan

Microchip Technology Taiwan  
11F-3, No. 207  
Tung Hua North Road  
Taipei, 105, Taiwan  
Tel: 886-2-2717-7175 Fax: 886-2-2545-0139

### EUROPE

#### Australia

Microchip Technology Australia Pty Ltd  
Suite 22, 41 Rawson Street  
Epping 2121, NSW  
Australia  
Tel: 61-2-9868-6733 Fax: 61-2-9868-6755

#### Denmark

Microchip Technology Denmark ApS  
Regus Business Centre  
Lautrup høj 1-3  
Ballerup DK-2750 Denmark  
Tel: 45 4420 9895 Fax: 45 4420 9910

#### France

Arizona Microchip Technology SARL  
Parc d'Activite du Moulin de Massy  
43 Rue du Saule Trapu  
Batiment A - 1er Etage  
91300 Massy, France  
Tel: 33-1-69-53-63-20 Fax: 33-1-69-30-90-79

#### Germany

Arizona Microchip Technology GmbH  
Gustav-Heinemann Ring 125  
D-81739 Munich, Germany  
Tel: 49-89-627-144 0 Fax: 49-89-627-144-44

#### Germany

Analog Product Sales  
Lochamer Strasse 13  
D-82152 Martinsried, Germany  
Tel: 49-89-895650-0 Fax: 49-89-895650-22

#### Italy

Arizona Microchip Technology SRL  
Centro Direzionale Colleoni  
Palazzo Taurus 1 V. Le Colleoni 1  
20041 Agrate Brianza  
Milan, Italy  
Tel: 39-039-65791-1 Fax: 39-039-6899883

#### United Kingdom

Arizona Microchip Technology Ltd.  
505 Eskdale Road  
Winnersh Triangle  
Wokingham  
Berkshire, England RG41 5TU  
Tel: 44 118 921 5869 Fax: 44-118 921-5820

All rights reserved. © 2001 Microchip Technology Incorporated. Printed in the USA. 1/01  Printed on recycled paper.

01/09/01

Information contained in this publication regarding device applications and the like is intended through suggestion only and may be superseded by updates. It is your responsibility to ensure that your application meets with your specifications. No representation or warranty is given and no liability is assumed by Microchip Technology Incorporated with respect to the accuracy or use of such information, or infringement of patents or other intellectual property rights arising from such use or otherwise. Use of Microchip's products as critical components in life support systems is not authorized except with express written approval by Microchip. No licenses are conveyed, implicitly or otherwise, except as may be explicitly expressed herein, under any intellectual property rights. The Microchip logo and name are registered trademarks of Microchip Technology Inc. in the U.S.A. and other countries. All rights reserved. All other trademarks mentioned herein are the property of their respective companies.

## Looking for pricing, stock, or lifecycle information?

Click below to explore more details on WIN SOURCE:

 [View TC7662BEOA713](#) on WIN SOURCE

 [Microchip Technology](#) Information

## Optimize Your Supply Chain with WIN SOURCE Solutions

-  Global Sourcing Solution
-  Obsolete Management
-  Cost Control Management
-  Shortage Management
-  Alternative Solution
-  Excess Inventory Management