



**THE DATASHEET OF  
PCF8883T/1,118**



# PCF8883

Capacitive touch/proximity switch with auto-calibration, large voltage operating range, and very low power consumption

Rev. 4.1 — 14 September 2016

Product data sheet

## 1. General description

---

The integrated circuit PCF8883 is a capacitive touch and proximity switch that uses a patented (EDISEN) digital method to detect a change in capacitance on a remote sensing plate. Changes in the static capacitance (as opposed to dynamic capacitance changes) are automatically compensated using continuous auto-calibration. Remote sensing plates (e.g. conductive foil) can be connected directly to the IC<sup>1</sup> or remotely using a coaxial cable.

## 2. Features and benefits

---

- Dynamic proximity switch
- Digital processing method
- Adjustable sensitivity, can be made very high
- Adjustable response time
- Wide input capacitance range (10 pF to 60 pF)
- Automatic calibration
- A large distance (several meters) between the sensing plate and the IC is possible
- Open-drain output (P-type MOSFET, external load between pin and ground)
- Designed for battery powered applications ( $I_{DD} = 3 \mu\text{A}$ , typical)
- Output configurable as push-button, toggle, or pulse
- Wide voltage operating range ( $V_{DD} = 3 \text{ V to } 9 \text{ V}$ )
- Large temperature operating range ( $T_{\text{amb}} = -40 \text{ }^\circ\text{C to } +85 \text{ }^\circ\text{C}$ )
- Internal voltage regulator
- Available in SOIC8 and wafer level chip-size package

## 3. Applications

---

- Proximity detection
- Proximity sensing in
  - ◆ Mobile phones
  - ◆ Portable entertainment units
- Switch for medical applications
- Switch for use in explosive environments
- Vandal proof switches
- Transportation: Switches in or under upholstery, leather, handles, mats, and glass

---

1. The definition of the abbreviations and acronyms used in this data sheet can be found in [Section 21](#).



- Buildings: switch in or under carpets, glass, or tiles
- Sanitary applications: use of standard metal sanitary parts (e.g. tap) as switch
- Hermetically sealed keys on a keyboard

## 4. Ordering information

**Table 1. Ordering information**

Type number	Package		
	Name	Description	Version
PCF8883T	SOIC8	plastic small outline package; 8 leads; body width 3.9 mm	PCF8883T
PCF8883US	WLCSP8	wafer level chip-size package; 8 bumps	PCF8883US

### 4.1 Ordering options

**Table 2. Ordering options**

Product type number	Orderable part number	Sales item (12NC)	Delivery form	IC revision
PCF8883T/1	PCF8883T/1,118	935289766118	tape and reel, 13 inch	1
PCF8883US/7EA/1	PCF8883US/7EA/1Y	935300777518	dry pack, tape and reel, 13 inch	1

## 5. Marking

**Table 3. Marking codes**

Product type number	Marking code
PCF8883T	PCF8883
PCF8883US	PC 8883-1

6. Block diagram

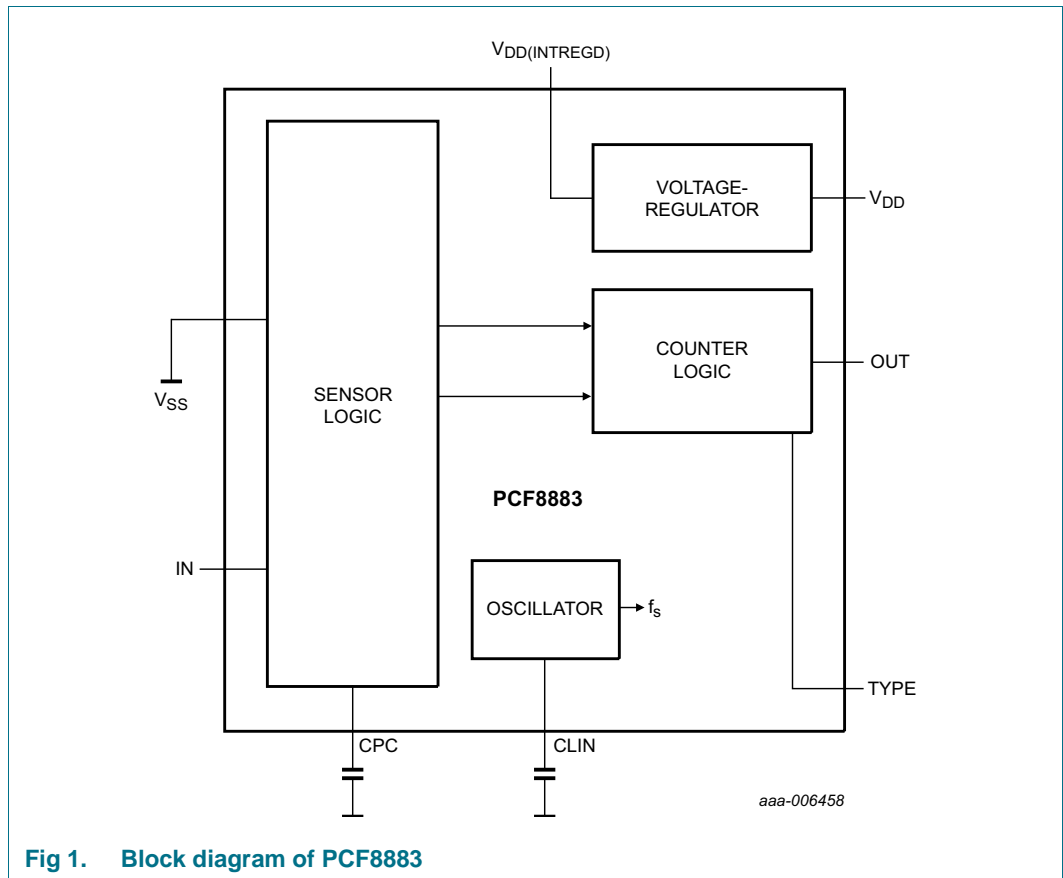
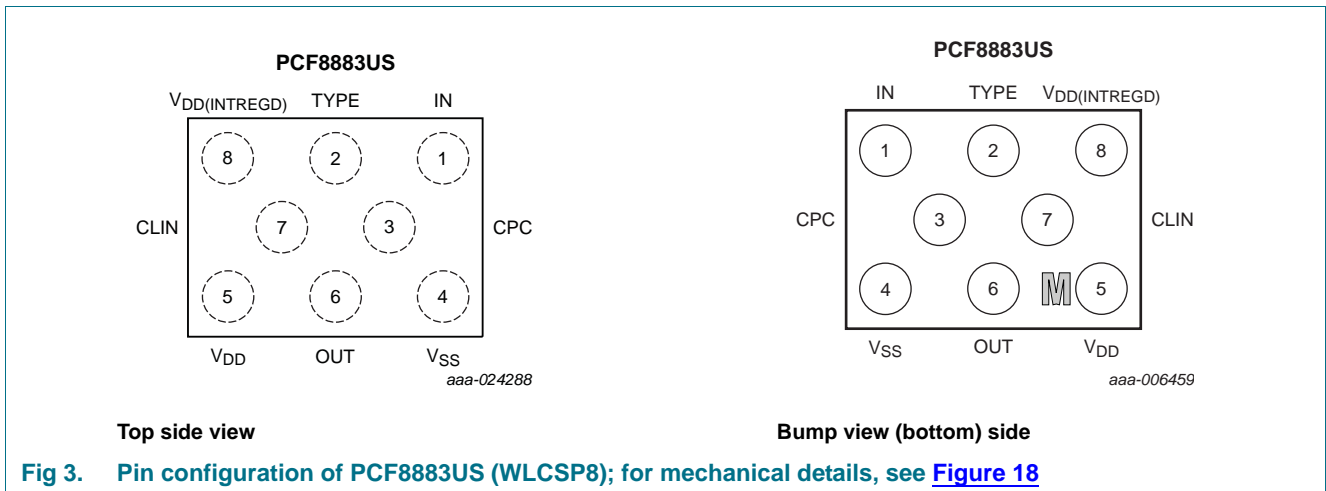
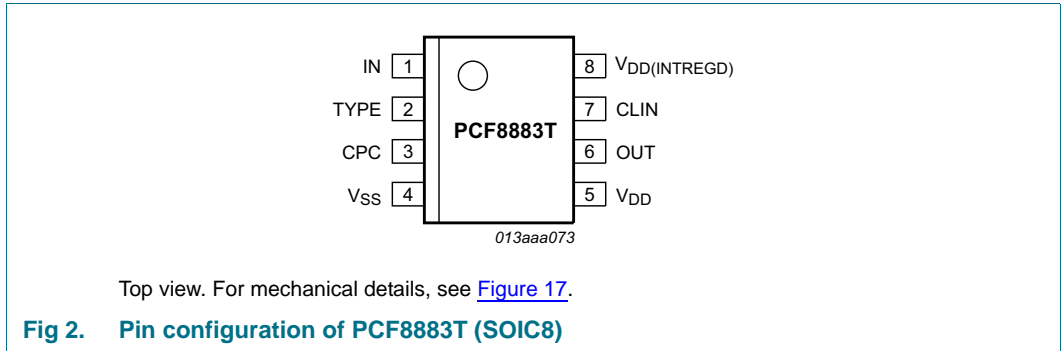

Fig 1. Block diagram of PCF8883

## 7. Pinning information

### 7.1 Pinning



## 7.2 Pin description

**Table 4. Pin description**

*Input or input/output pins must always be at a defined level ( $V_{SS}$  or  $V_{DD}$ ) unless otherwise specified.*

Symbol	Pin		Type	Description
	PCF8883T	PCF8883US		
IN	1	1	analog input/output	sensor input
TYPE	2	2	input	pin OUT behavior configuration input
CPC	3	3	analog input/output	sensitivity setting
$V_{SS}$ <sup>[1]</sup>	4	4	supply	ground supply voltage
$V_{DD}$	5	5	supply	supply voltage
OUT	6	6	output	switch output
CLIN	7	7	analog input/output	sampling rate setting
$V_{DD(INTREGD)}$ <sup>[2]</sup>	8	8	supply	internal regulated supply voltage output

[1] The substrate (rear side of the die) is connected to  $V_{SS}$  and should be electrically isolated.

[2] The internal regulated supply voltage output must be decoupled with a decoupling capacitor to  $V_{SS}$ .

## 8. Functional description

[Figure 4](#) and [Figure 5](#) show the functional principle of the PCF8883.

The discharge time ( $t_{dch}$ ) of a chip-internal RC timing circuit, to which the external sensing plate is connected via pin IN, is compared to the discharge time ( $t_{dch(ref)}$ ) of a second chip-internal reference RC timing circuit. Both RC timing circuits are periodically charged from  $V_{DD(INTREGD)}$  via identical switches and then discharged via a resistor to ground ( $V_{SS}$ ). Both switches are synchronized.

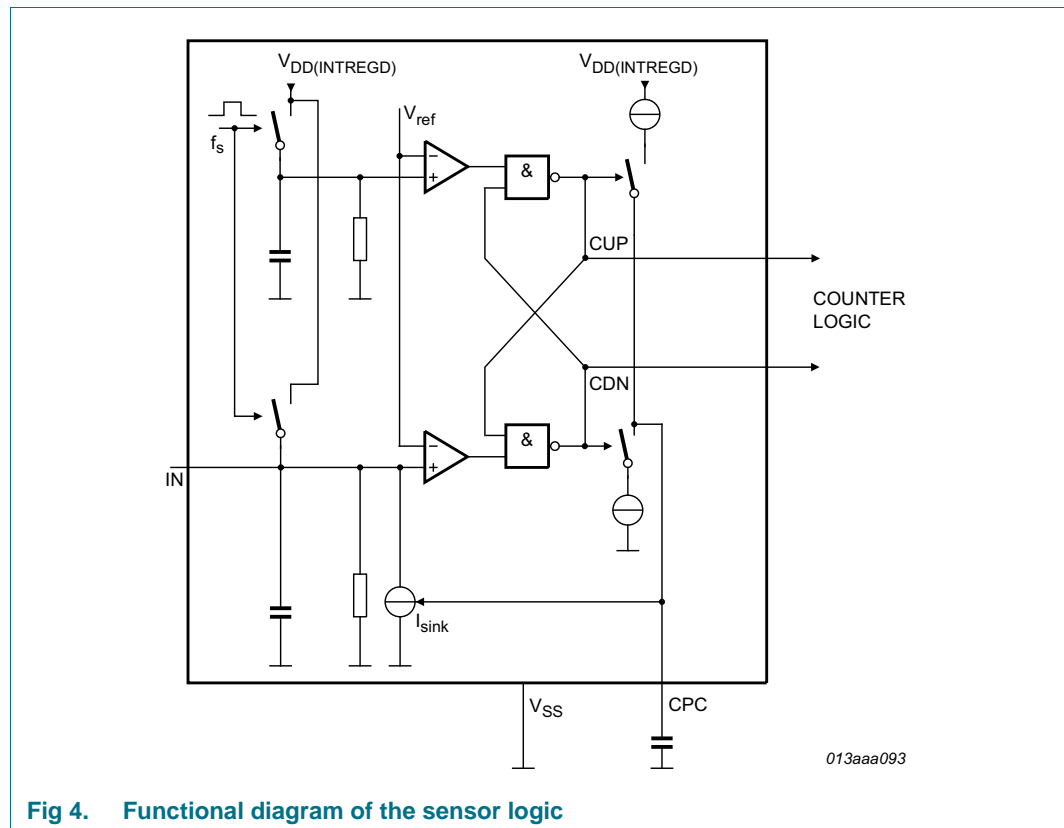

**Fig 4. Functional diagram of the sensor logic**

The charge-discharge cycle is governed by the sampling rate ( $f_s$ ). If the voltage of one of the RC timing circuits falls below the internal reference voltage  $V_{ref}$ , the respective comparator output becomes LOW. The logic following the comparators determines which comparator switches first. If the upper (reference) comparator switches, then a pulse is given on CUP. If the lower (input) comparator switches first, then a pulse is given on CDN (see [Figure 4](#)).

The pulses control the charge on the external capacitor  $C_{CPC}$  on pin CPC. Every time a pulse is given on CUP, capacitor  $C_{CPC}$  is charged from  $V_{DD(INTREGD)}$  for a fixed time causing the voltage on  $C_{CPC}$  to rise. Likewise when a pulse occurs on CDN, capacitor  $C_{CPC}$  is connected to a current sink to ground for a fixed time causing the voltage on  $C_{CPC}$  to fall.

If the capacitance on pin IN increases, the discharge time  $t_{dch}$  increases too. Therefore it takes longer for the voltage on the corresponding comparator to drop below  $V_{ref}$ . Only once this happens, the comparator output becomes LOW and this results in a pulse on CDN discharging the external capacitor  $C_{CPC}$  slightly. Thus most pulses will now be given by CUP. Without further action, capacitor  $C_{CPC}$  would then fully charge.

However, a chip-internal automatic calibration mechanism that is based on a voltage controlled sink current ( $I_{sink}$ ) connected to pin IN attempts to equalize the discharge time  $t_{dch}$  with the internal reference discharge time  $t_{dch(ref)}$ . The current source is controlled by the voltage on  $C_{CPC}$  which causes the capacitance on pin IN to be discharged more quickly in the case that the voltage on  $C_{CPC}$  is rising, thereby compensating for the increase in capacitance on input pin IN. This arrangement constitutes a closed-loop control system that constantly attempts to equalize the discharge time  $t_{dch}$  with  $t_{dch(ref)}$ . This allows compensating for slow changes in capacitance on input pin IN. Fast changes due to an approaching hand for example will not be compensated. In the equilibrium state, the discharge times are equal and the pulses alternate between CUP and CDN.

From this also follows, that an increase in capacitor value  $C_{CPC}$  results in a smaller voltage change per pulse CUP or CDN. Thus the compensation due to internal current sink source  $I_{sink}$  is slower and therefore the sensitivity of the sensor increases. Likewise a decrease in capacitor  $C_{CPC}$  results in a lower sensitivity. (For further information see [Section 14.](#))

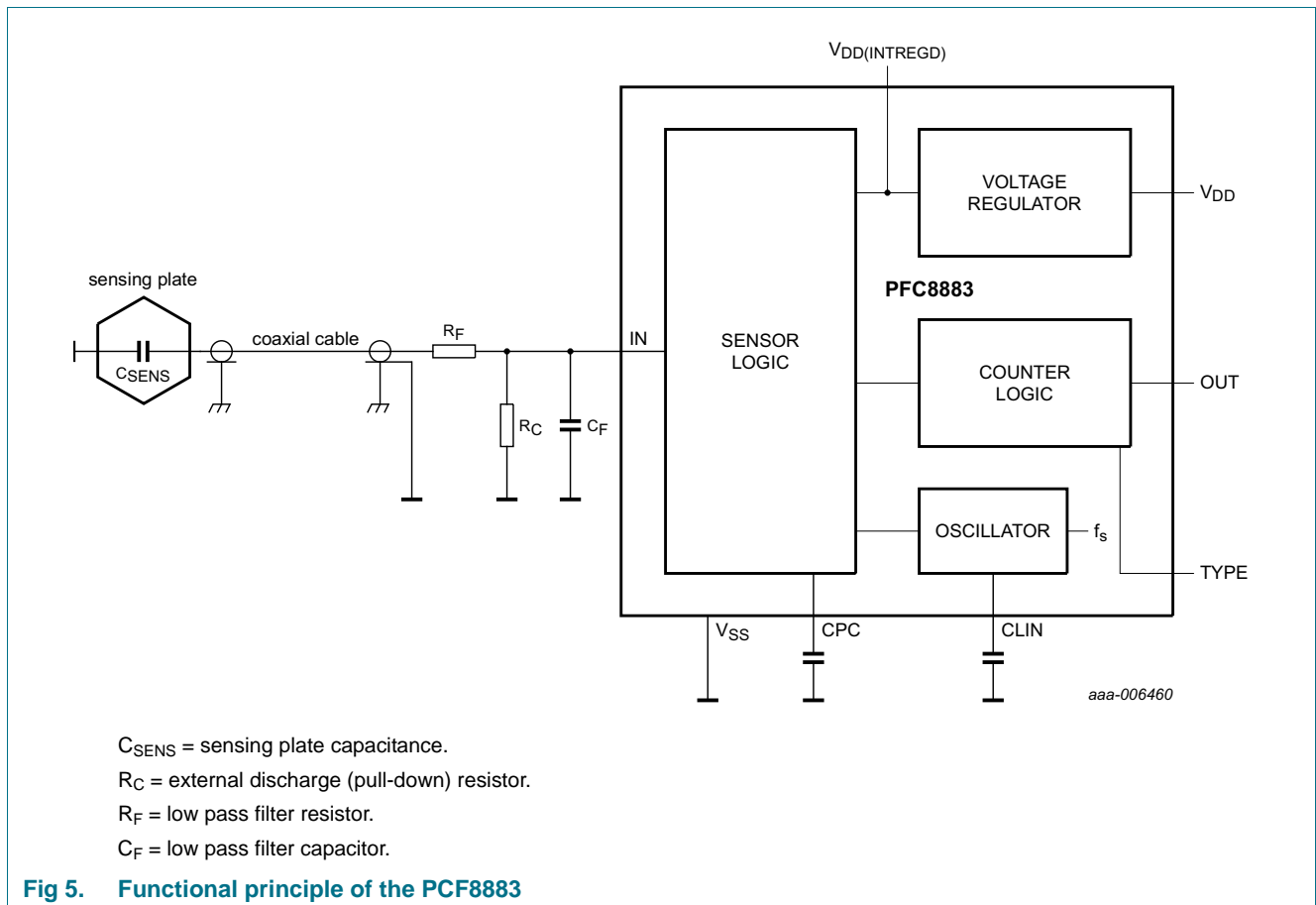

The counter, following the sensor logic depicted in [Figure 4](#), counts the pulses of CUP or CDN respectively. The counter is reset every time the pulse sequence changes from CUP to CDN or the other way around. Pin OUT will only be activated when enough consecutive CUP or CDN pulses occur. Low-level interference or slow changes in the input capacitance do not cause the output to switch.

Various measures, such as asymmetrical charge and discharge steps, are taken to ensure that the output switches off correctly. A special start-up circuit ensures that the device reaches equilibrium quickly when the supply is attached.

Pin OUT is an open-drain output capable of pulling an external load  $R_{\text{ext}}$  (at maximum current of 20 mA) up to  $V_{\text{DD}}$ . The load resistor must be dimensioned appropriately, taking the maximum expected  $V_{\text{DD}}$  voltage into account. The output is automatically deactivated (short circuit protection) for loads in excess of 30 mA. Pin OUT can also drive a CMOS input without connection of the external load.

A small internal 150 nA current sink  $I_{\text{sink}}$  enables a full voltage swing to take place on pin OUT, even if no load resistor is connected. This is useful for driving purely capacitive CMOS inputs. The falling slope can be fairly slow in this mode, depending on load capacitance.

The sampling rate ( $f_s$ ) corresponds to half of the frequency used in the RC timing circuit. The sampling rate can be adjusted within a specified range by selecting the value of  $C_{\text{CLIN}}$ . The oscillator frequency is internally modulated by 4 % using a pseudo random signal. This prevents interference caused by local AC-fields.

## 8.1 Output switching modes

The output switching behavior can be selected using pin TYPE (see [Figure 6](#)).

- Push-button (TYPE connected to  $V_{\text{SS}}$ ): The output OUT is active as long as the capacitive event<sup>2</sup> lasts.
- Toggle (TYPE connected to  $V_{\text{DD(INTREGD)}}$ ): The output OUT is activated by the first capacitive event and deactivated by a following capacitive event.
- Pulse ( $C_{\text{TYPE}}$  connected between TYPE and  $V_{\text{SS}}$ ): The output OUT is activated for a defined time at each capacitive event. The pulse duration is determined by the value of  $C_{\text{TYPE}}$  and is approximately 2.5 ms/nF.

A typical value for  $C_{\text{TYPE}}$  is 4.7 nF which results in an output pulse duration of about 10 ms. The maximum value of  $C_{\text{TYPE}}$  is 470 nF which results in a pulse duration of about 1 s. Capacitive events are ignored that occur during the time the output is active.

[Figure 6](#) illustrates the switching behavior for the output switching modes. Additionally the graph illustrates, that short-term disturbances on the sensor are suppressed by the circuit.

2. A capacitive event is a dynamic increase of capacitance at the sensor input pin IN.

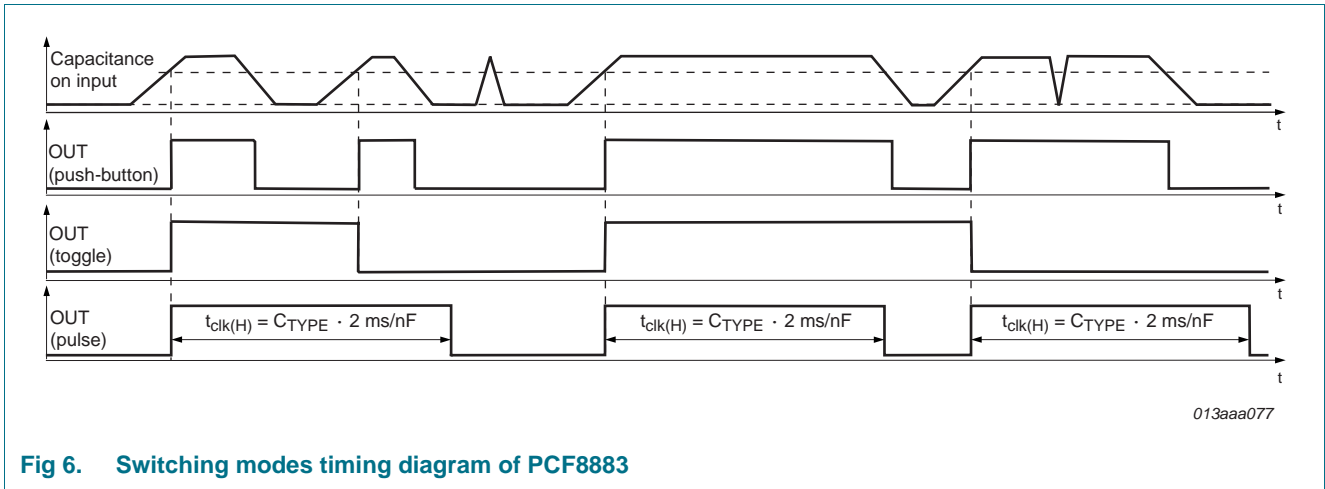

Fig 6. Switching modes timing diagram of PCF8883

### 8.2 Voltage regulator

The PCF8883 implements a chip-internal voltage regulator supplied by pin  $V_{DD}$  that provides an internal supply ( $V_{DD(INTREGD)}$ ) limited to a maximum of 4.6 V. The lock-in voltage  $V_{lockin}$  on  $V_{DD}$  is typically 4.0 V. Figure 7 shows the relationship between  $V_{DD}$  and  $V_{DD(INTREGD)}$ .

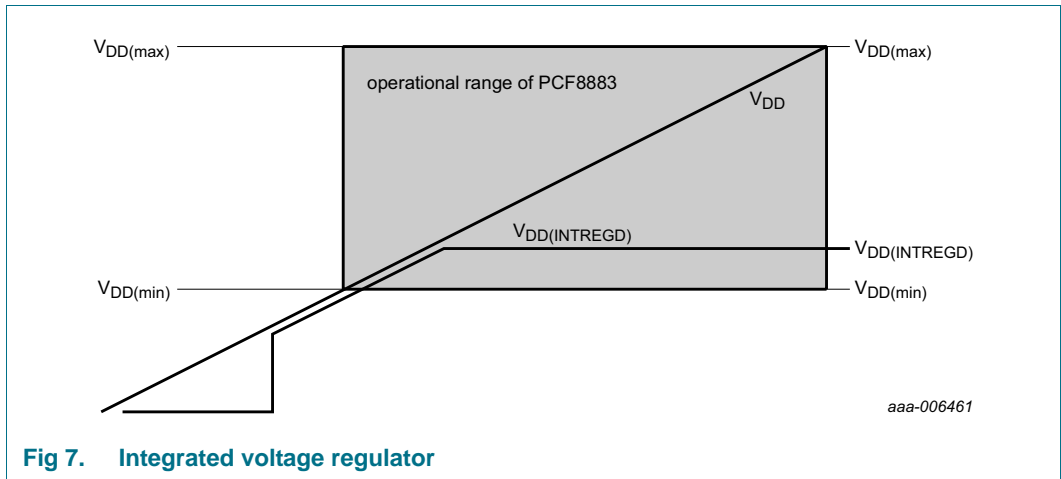

Fig 7. Integrated voltage regulator

## 9. Safety notes

### CAUTION



This device is sensitive to ElectroStatic Discharge (ESD). Observe precautions for handling electrostatic sensitive devices.

Such precautions are described in the *ANSI/ESD S20.20*, *IEC/ST 61340-5*, *JESD625-A* or equivalent standards.

### CAUTION



Semiconductors are light sensitive. Exposure to light sources can cause the IC to malfunction. The IC must be protected against light. The protection must be applied to all sides of the IC.

## 10. Limiting values

**Table 5. Limiting values**

*In accordance with the Absolute Maximum Rating System (IEC 60134).*

Symbol	Parameter	Conditions	Min	Max	Unit	
$V_{DD}$	supply voltage		-0.5	+9	V	
$V_I$	input voltage	on pins IN, TYPE, CPC	-0.5	$V_{DD(INTREGD)} + 0.5$	V	
$I_O$	output current	on pin OUT	-10	+50	mA	
$I_{SS}$	ground supply current		-10	+50	mA	
$I_I$	input current	on any other pin	-10	+10	mA	
$P_{tot}$	total power dissipation		-	100	mW	
$V_{ESD}$	electrostatic discharge voltage	HBM	[1]	-	±2500	V
		MM	[2]	-	±200	V
$I_{lu}$	latch-up current		[3]	-	100	mA
$T_{stg}$	storage temperature		[4]	-60	+125	°C
$T_{amb}$	ambient temperature	operating device	-40	+85	°C	

[1] Pass level; Human Body Model (HBM) according to [Ref. 9 "JESD22-A114"](#).

[2] Pass level; Machine Model (MM), according to [Ref. 10 "JESD22-A115"](#).

[3] Pass level; latch-up testing, according to [Ref. 11 "JESD78"](#) at maximum ambient temperature ( $T_{amb(max)}$ ).

[4] According to the store and transport requirements (see [Ref. 14 "UM10569"](#)) the devices have to be stored at a temperature of +8 °C to +45 °C and a humidity of 25 % to 75 %.

## 11. Static characteristics

**Table 6. Static characteristics**

$V_{DD} = 5\text{ V}$ ,  $T_{amb} = +25\text{ °C}$ ; unless otherwise specified.

Symbol	Parameter	Conditions	Min	Typ	Max	Unit
$V_{DD}$	supply voltage	$10\text{ pF} \leq C_i \leq 40\text{ pF}$ ; $-40\text{ °C} \leq T_{amb} \leq +85\text{ °C}$ [1]	3.0	-	9.0	V
		$10\text{ pF} \leq C_i \leq 35\text{ pF}$ ; $-20\text{ °C} \leq T_{amb} \leq +85\text{ °C}$ [2]	2.8	-	9.0	V
$V_{DD(\text{INTREGD})}$	internal regulated supply voltage		3.0	4.0	4.6	V
$\Delta V_{DD(\text{INTREGD})}$	internal regulated supply voltage variation	regulator voltage drop	-	10	50	mV
$I_{DD}$	supply current	idle state; $f_s = 1\text{ kHz}$ [3]				
		$V_{DD} = 5.0\text{ V}$	-	3	5	$\mu\text{A}$
		$V_{DD} = 3.0\text{ V}$	-	2.2	3.5	$\mu\text{A}$
$I_{\text{sink}}$	sink current	internal constant current to $V_{SS}$	-	150	-	nA
$V_O$	output voltage	on pin OUT; pull-up voltage	0	$V_{DD}$	9.0	V
$I_O$	output current	P-MOS [4]	0	10	20	mA
		short circuit protection $V_O \geq 0.6\text{ V}$	20	30	50	mA
$V_{\text{sat}}$	saturation voltage	on pin OUT; $I_O = +10\text{ mA}$				
		$V_{DD} = 5.0\text{ V}$	0.1	0.2	0.4	V
		$V_{DD} = 3.0\text{ V}$	0.1	0.3	0.5	V
$C_{\text{dec}}$	decoupling capacitance	on pin $V_{DD(\text{INTREGD})}$ [5]	100	-	220	nF
$V_{I(\text{CPC})}$	input voltage on pin CPC		0.6	-	$V_{DD(\text{INTREGD})} - 0.5$	V

[1] Alternatively an external discharge resistor  $R_C$  can be used (see [Section 14](#)).

[2] Tested on sample basis.

[3] Idle state is the steady state after completed power-on without any activity on the sensor plate and the voltage on the reservoir capacitor  $C_{CPC}$  settled.

[4] For reliability reasons, the average output current must be limited to 4.6 mA at 70 °C and 3.0 mA at 85 °C.

[5] External ceramic chip capacitor recommended (see [Figure 16](#)).

## 12. Dynamic characteristics

**Table 7. Dynamic characteristics**

$V_{DD} = 5\text{ V}$ ,  $C_{CLIN} = 22\text{ pF}$ ,  $C_{CPC} = 470\text{ nF}$ ,  $T_{amb} = +25\text{ °C}$ ; unless otherwise specified.

Symbol	Parameter	Conditions	Min	Typ	Max	Unit
$C_{CLIN}$	capacitance on pin CLIN		0	22	100	pF
$C_{CPC}$	capacitance on pin CPC	X7R ceramic chip capacitor	90	470	2500	nF
$N_{res(dig)eq}$	equivalent digital resolution		-	14	-	bit
$C_{TYPE}$	capacitance on pin TYPE		0.1	-	470	nF
$C_i$	input capacitance	sensing plate and connecting cable				
		$V_{DD} = 5.0\text{ V}$	10	-	60	pF
		$T_{amb} = -40\text{ °C to }+85\text{ °C}$ ; $V_{DD} = 3.0\text{ V}$	10	-	40	pF
$t_{startup}$	start-up time	until normal operation is established	-	0.5	-	s
$t_p$	pulse duration	on pin OUT; in pulse mode; $C_{TYPE} \geq 10\text{ nF}$	-	2.5	-	ms/nF
$f_s$	sampling frequency	$C_{CLIN} = 0\text{ pF}$	-	3.3	-	kHz
		$C_{CLIN} = 22\text{ pF}$ (typical value)	-	1	-	kHz
		$C_{CLIN} = 100\text{ pF}$	-	275	-	Hz
$t_{sw}$	switching time	at $f_s = 1\text{ kHz}$	-	64	-	ms

## 13. Characteristic curves

### 13.1 Power consumption

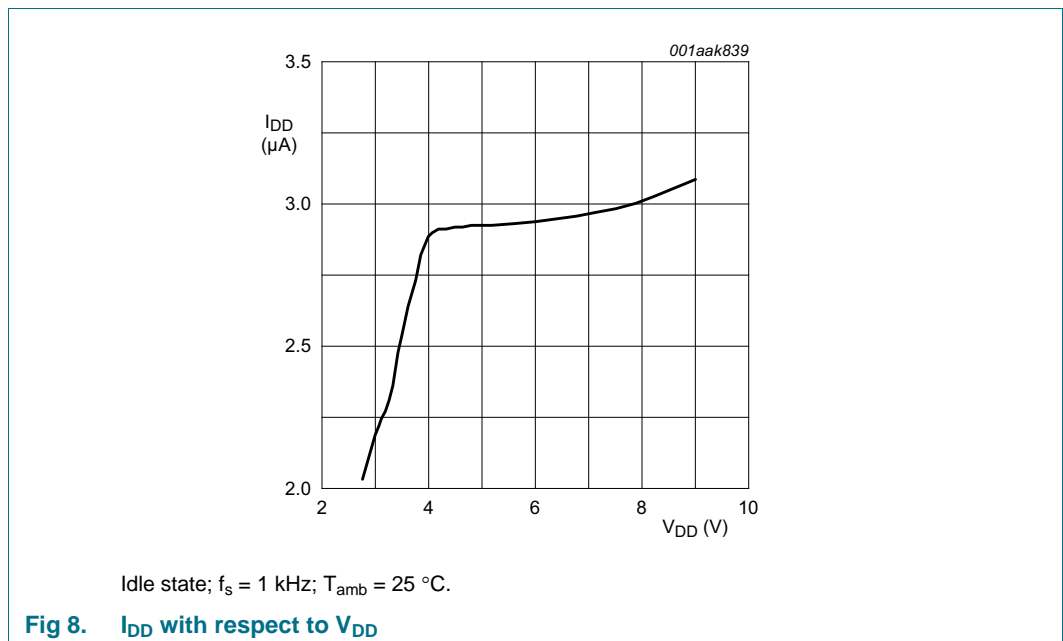

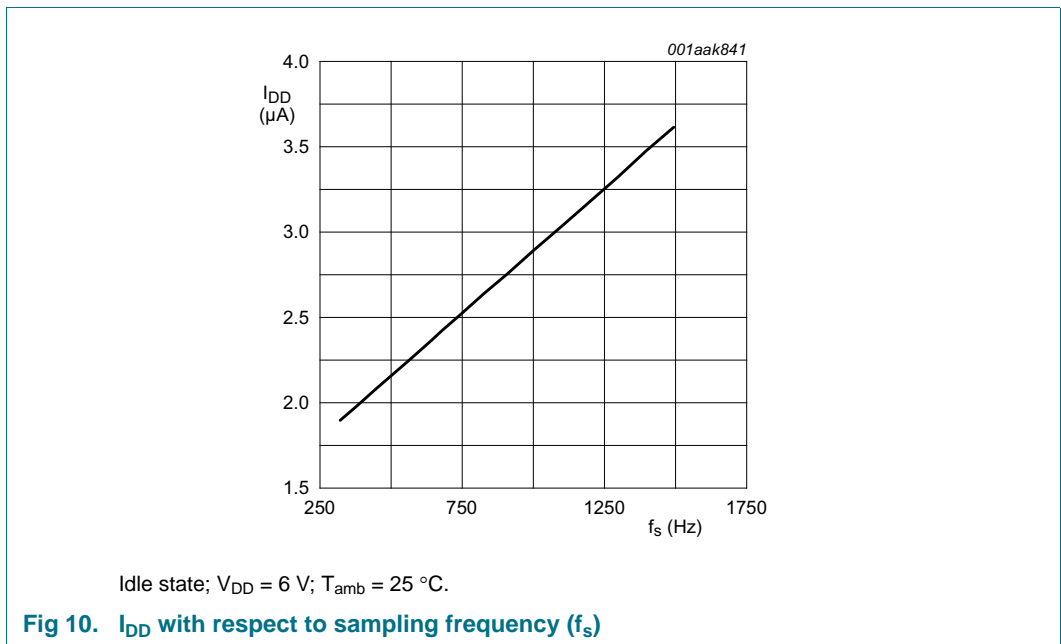
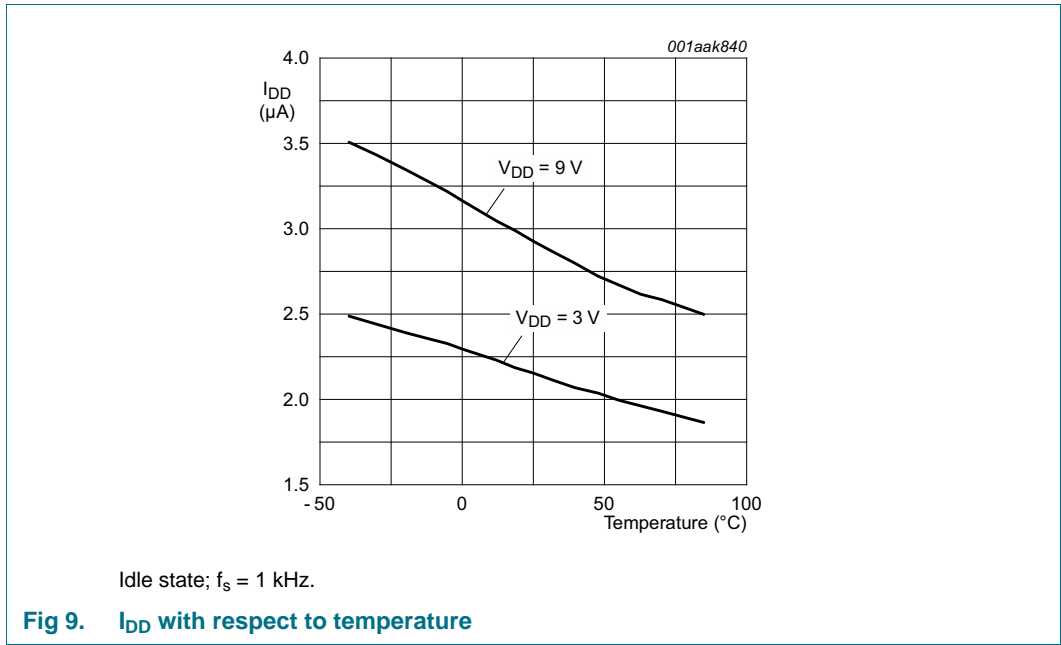

### 13.2 Typical reaction time

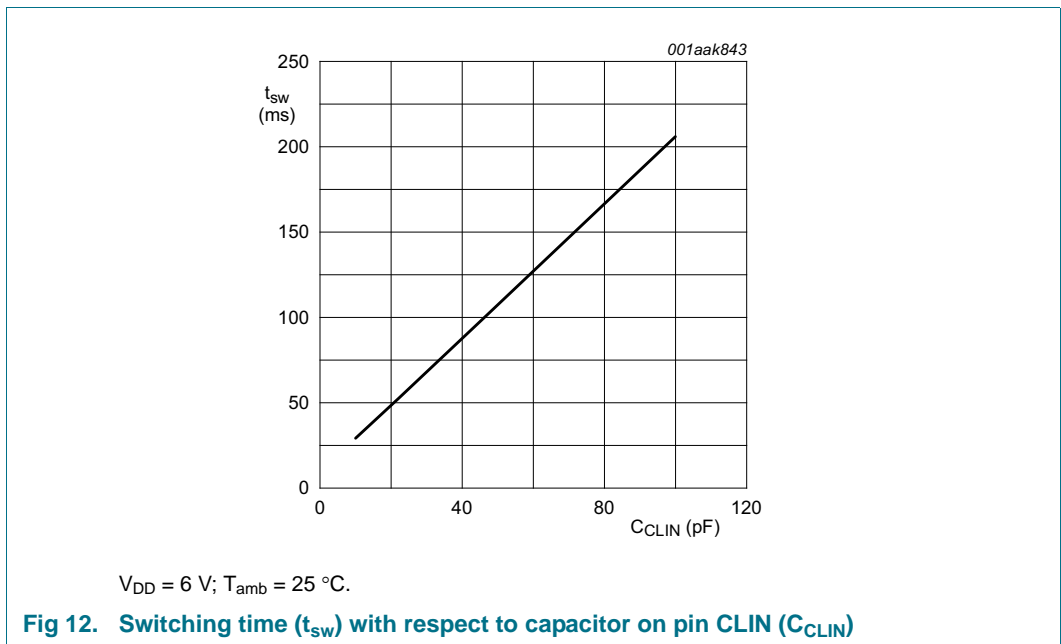
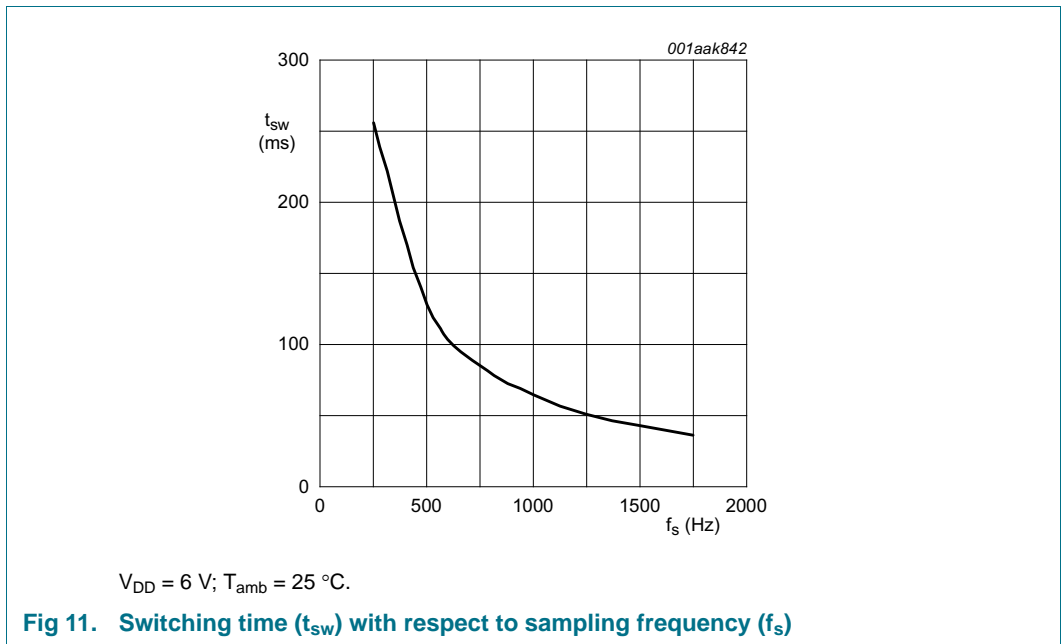

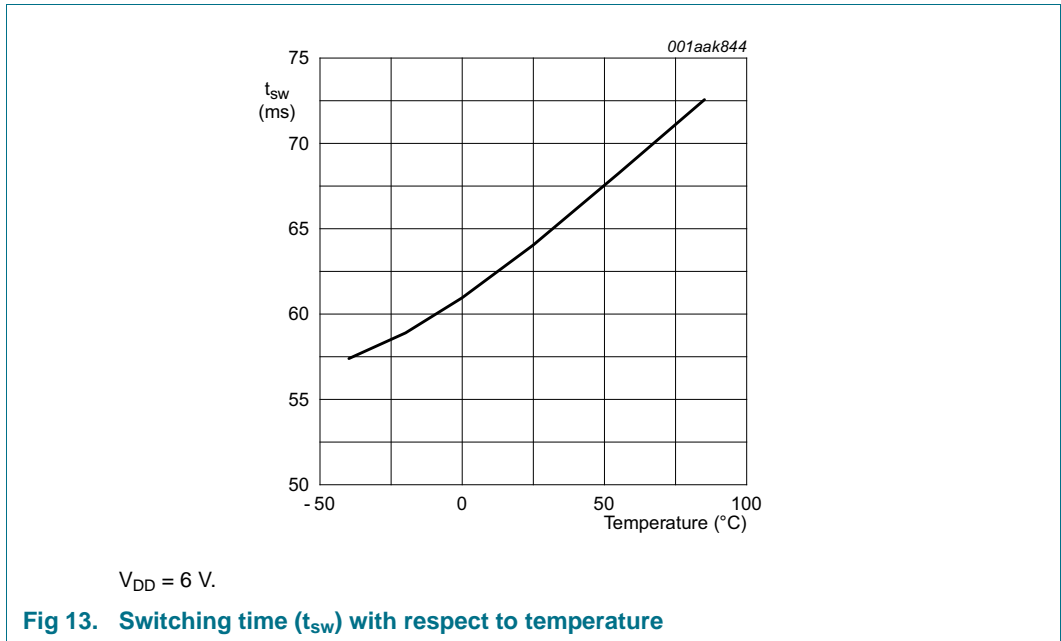

### 13.3 Reservoir capacitor voltage

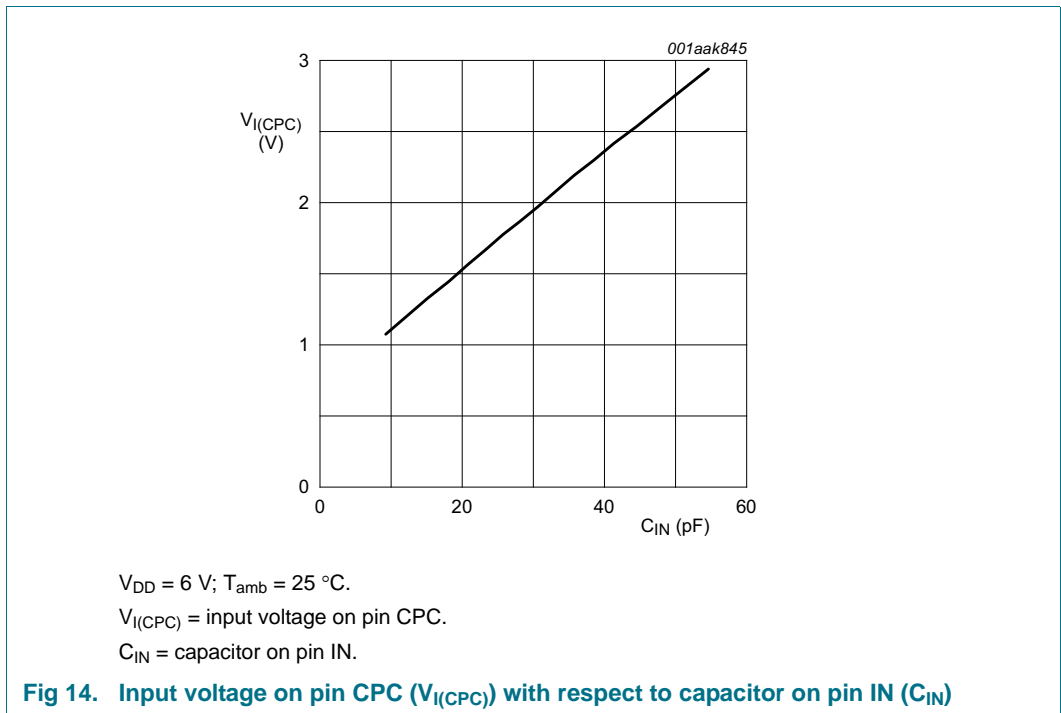

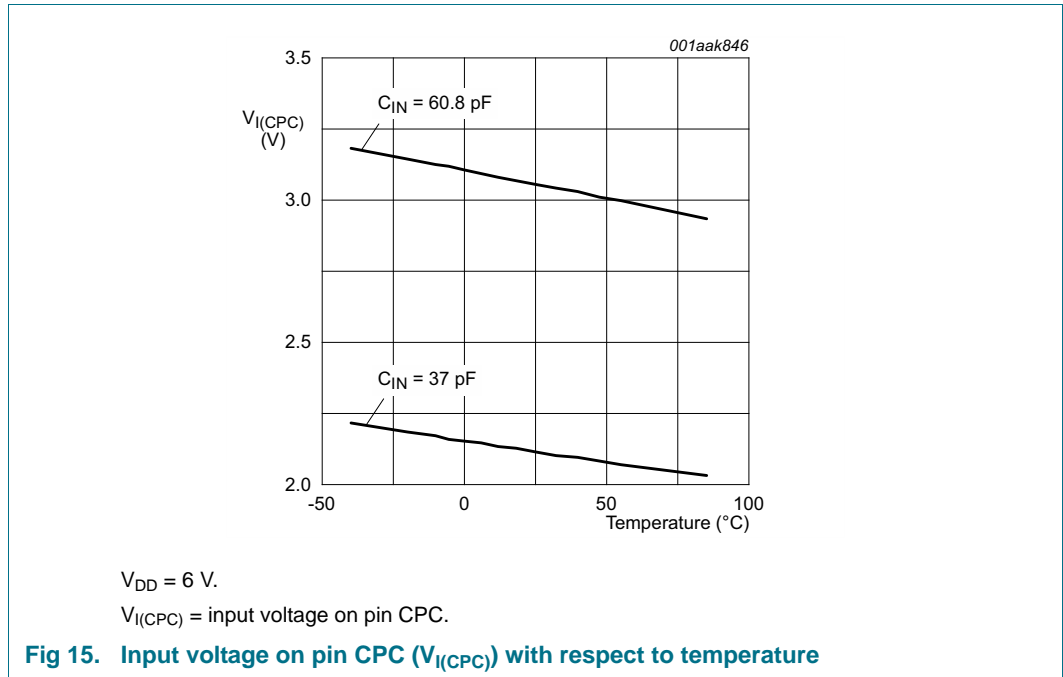

## 14. Application information

[Figure 16](#) shows the typical connections for a general application<sup>3</sup>. The positive supply is connected to pin  $V_{DD}$ . It is recommended to connect smoothing capacitors to ground to both  $V_{DD}$  and  $V_{DD(INTREGD)}$  (values for  $C_{dec}$ , see [Table 6](#)).

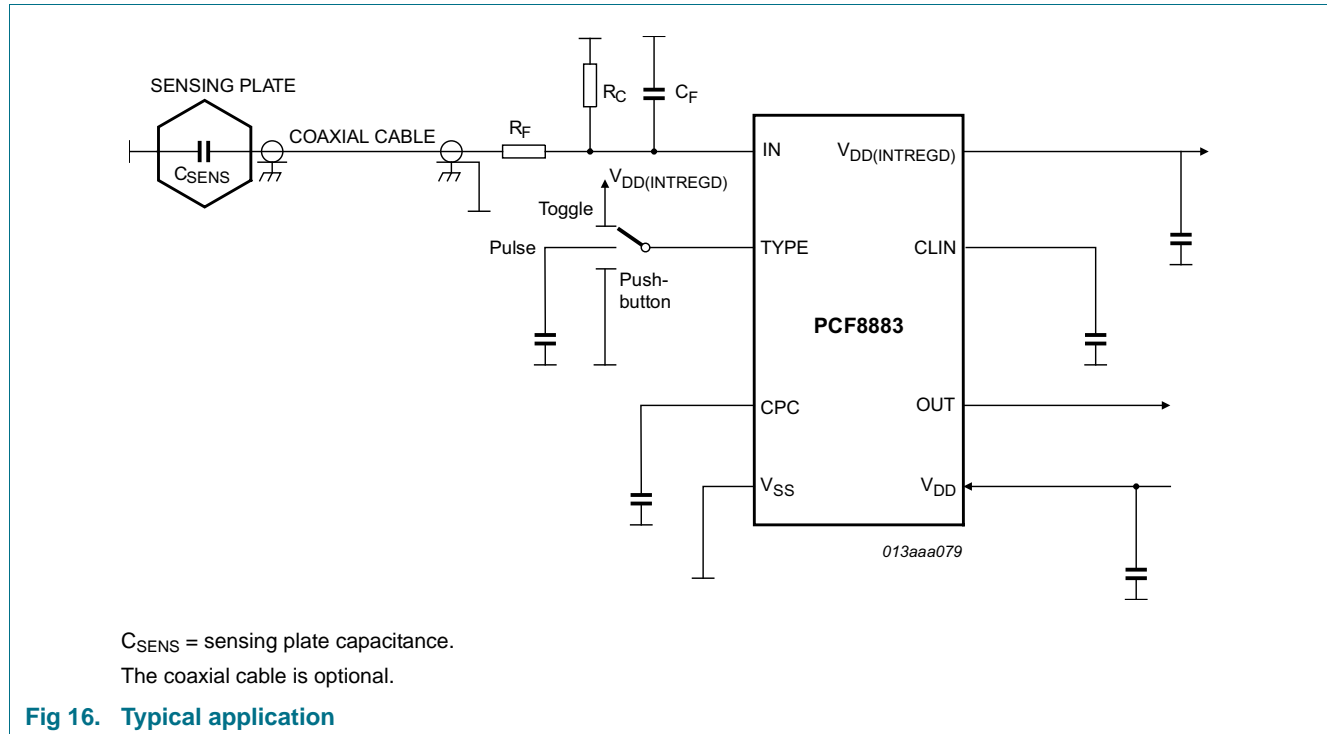

The sampling rate is determined by the capacitance  $C_{CLIN}$  on pin CLIN. A higher sampling rate reduces the reaction time and increases the current consumption.

The sensing plate capacitance  $C_{SENS}$  may consist of a small metal area, for example behind an isolating layer. The sensing plate can be connected to a coaxial cable ( $C_{CABLE}$ ) which in turn is connected to the input pin IN. Alternatively, the sensing plate can be directly connected to the input pin IN. An internal low pass filter is used to reduce RF interference. An additional low pass filter consisting of a resistor  $R_F$  and capacitor  $C_F$  can be added to the input to further improve RF immunity as required. For good performance, the total amount of capacitance on the input ( $C_{SENS} + C_{CABLE} + C_F$ ) should be in the proper range, the optimum point being around 30 pF. These conditions allow the control loop to adapt to the static capacitance on  $C_{SENS}$  and to compensate for slow changes in the sensing plate capacitance. A higher capacitive input loading is possible if an additional discharge resistor  $R_C$  is placed as shown in [Figure 16](#). Resistor  $R_C$  simply reduces the discharge time such that the internal timing requirements are fulfilled.

The sensitivity of the sensor can be influenced by the sensing plate area and capacitor  $C_{CPC}$ . The sensitivity is significantly reduced when  $C_{CPC}$  is reduced. When maximum sensitivity is desired  $C_{CPC}$  can be increased, but this also increases sensitivity to interference. Pin CPC has high-impedance and is sensitive to leakage currents.

3. For further information, see [Ref. 4 "AN10832"](#). Information about the appropriate evaluation board can be found in [Ref. 13 "UM10370"](#).

**Remark:**  $C_{CPC}$  should be a high-quality foil or ceramic capacitor, for example an X7R type.

When limiting the maximum input capacitance to 35 pF and the minimum operating temperature to  $-20\text{ }^{\circ}\text{C}$  then the minimum operating voltage can be reduced to 2.8 V. The main limitation when lowering the supply voltage is a reduction in the range of the  $V_{I(CPC)}$  voltage, which is specified from 0.6 V to  $V_{DD} - 0.3$  V. Reducing the  $V_{I(CPC)}$  working range is equivalent to reducing the input capacitance range. Additionally,  $V_{I(CPC)}$  increases with decreasing temperature, as illustrated in [Figure 14](#) and [Figure 15](#). This means that it is possible to lower the supply voltage if the minimum temperature will be raised accordingly.

For the choice of proper component values for a given application, the component specifications in [Table 6](#) and [Table 7](#) must be followed.

15. Package outline

SOIC8: plastic small outline package; 8 leads; body width 3.9 mm

PCF8883T

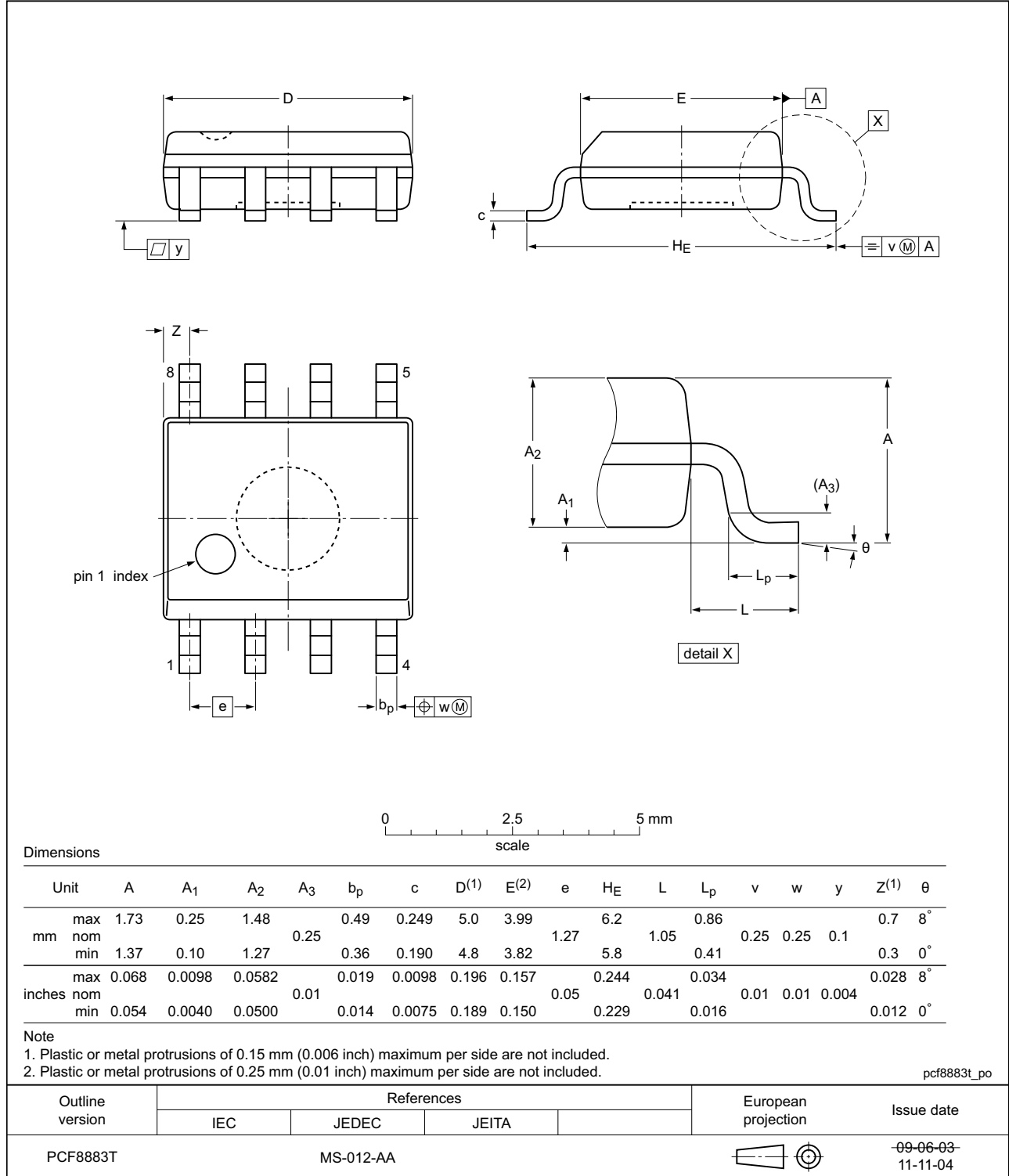

Fig 17. Package outline of PCF8883T (SOIC8)

## 16. Bare die outline

WLCSP8: wafer level chip-size package; 8 bumps

PCF8883US

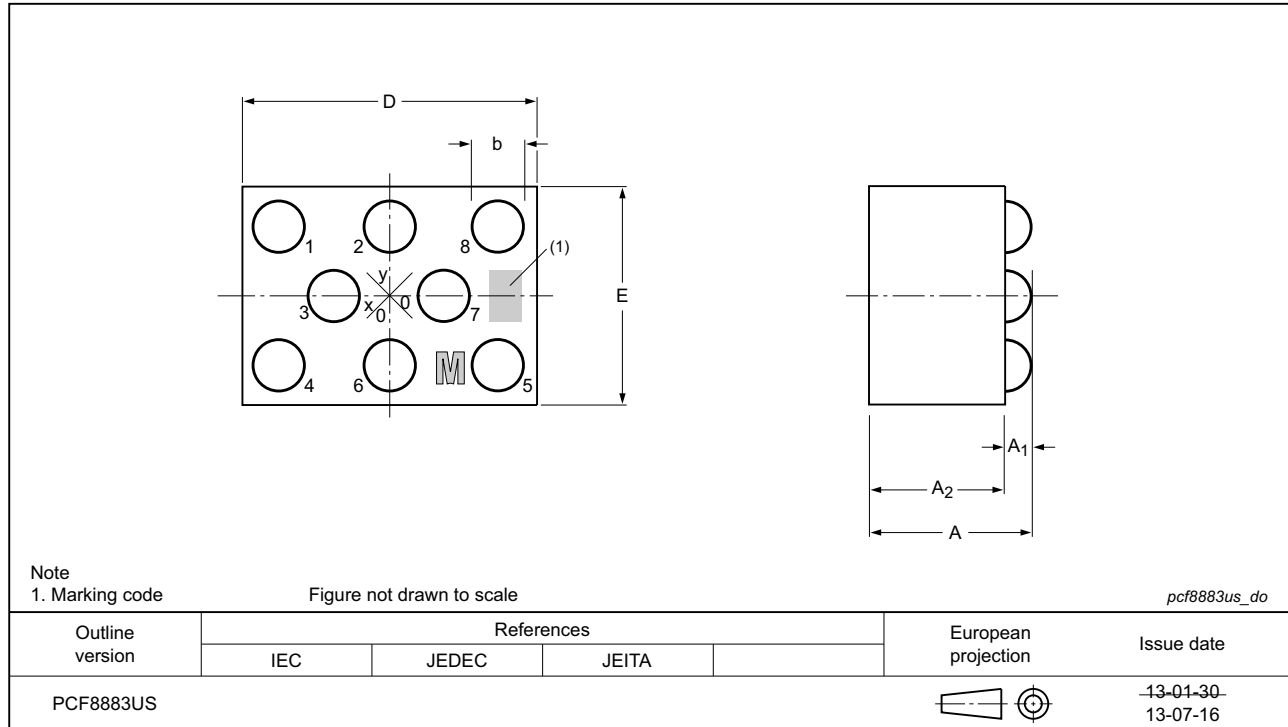

Fig 18. WLCSP8 outline of PCF8883US

Table 8. Dimension of PCF8883US

Original dimensions are in mm.

Unit (mm)	A	A <sub>1</sub>	A <sub>2</sub>	b	D	E
max	-	-	-	-	1.19	0.89
nom	0.55	0.11	0.44	0.2	1.16	0.86
min	-	-	-	-	1.13	0.83

Table 9. Solder bump locations

All coordinates are in  $\mu\text{m}$  and referenced to the center of the die (see [Figure 18](#)).

Symbol	Pin	X	Y	Type	Description
IN	1	-430	280	analog input/output	sensor input
TYPE	2	0	280	input	pin OUT behavior configuration input
CPC	3	-225	0	analog input/output	sensitivity setting
V <sub>SS</sub>	4	-430	-280	supply	ground supply voltage
V <sub>DD</sub>	5	430	-280	supply	supply voltage
OUT	6	0	-280	output	switch output
CLIN	7	225	0	analog input/output	sampling rate setting
V <sub>DD</sub> (INTREGD)	8	430	280	supply	internal regulated supply voltage output

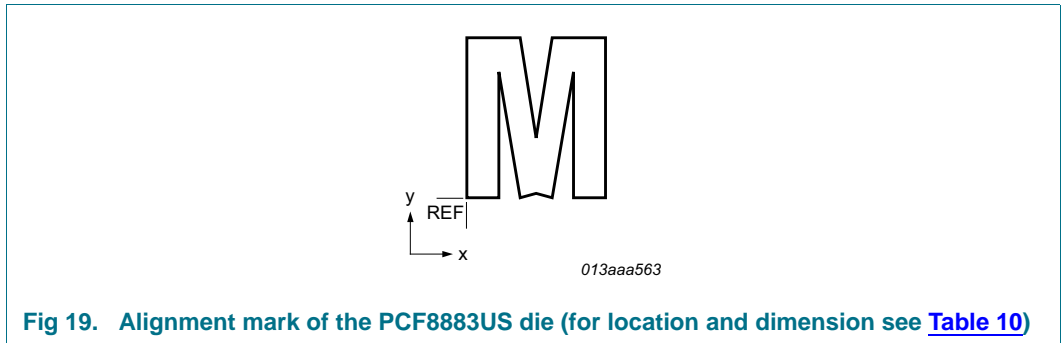

Fig 19. Alignment mark of the PCF8883US die (for location and dimension see [Table 10](#))

Table 10. Alignment mark dimension and location

Coordinates	
x	y
<b>Location<sup>[1]</sup></b>	
172 μm	-371 μm
<b>Dimension<sup>[2]</sup></b>	
117 μm	131 μm

- [1] The x/y coordinates of the alignment mark location represent the position of the REF point (see [Figure 19](#)) with respect to the center (x/y = 0) of the chip.
- [2] The x/y values of the dimensions represent the extensions of the alignment mark in direction of the coordinate axis (see [Figure 19](#)).

## 17. Handling information

All input and output pins are protected against ElectroStatic Discharge (ESD) under normal handling. When handling Metal-Oxide Semiconductor (MOS) devices ensure that all normal precautions are taken as described in *JESD625-A*, *IEC 61340-5* or equivalent standards.

## 18. Packing information

### 18.1 Tape and reel information

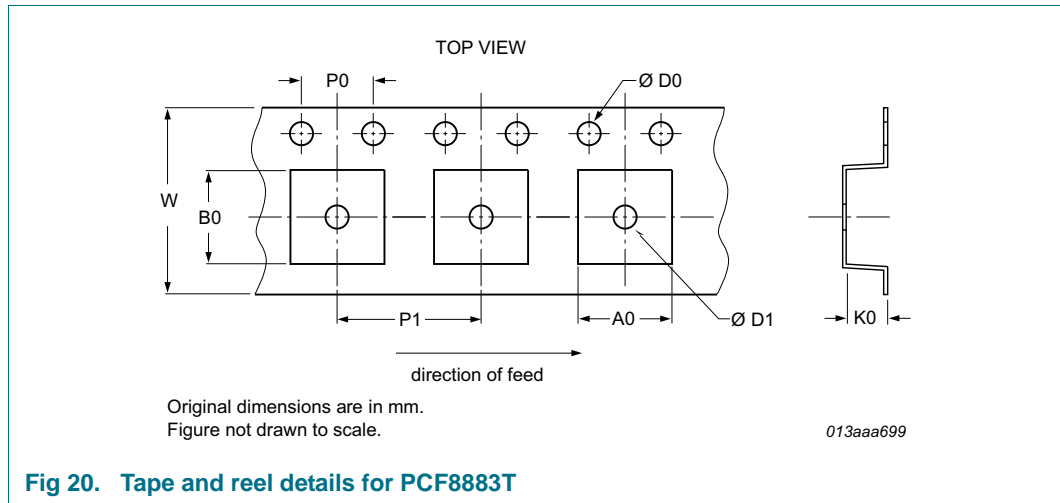

Fig 20. Tape and reel details for PCF8883T

Table 11. Carrier tape dimensions of PCF8883T

Nominal values without production tolerances.

Symbol	Description	Value	Unit
<b>Compartments</b>			
A0	pocket width in x direction	6.3 to 6.5	mm
B0	pocket width in y direction	5.4	mm
K0	pocket depth	2.05 to 2.1	mm
P1	pocket hole pitch	8	mm
D1	pocket hole diameter	1.5	mm
<b>Overall dimensions</b>			
W	tape width	12	mm
D0	sprocket hole diameter	1.5 to 1.55	mm
P0	sprocket hole pitch	4	mm

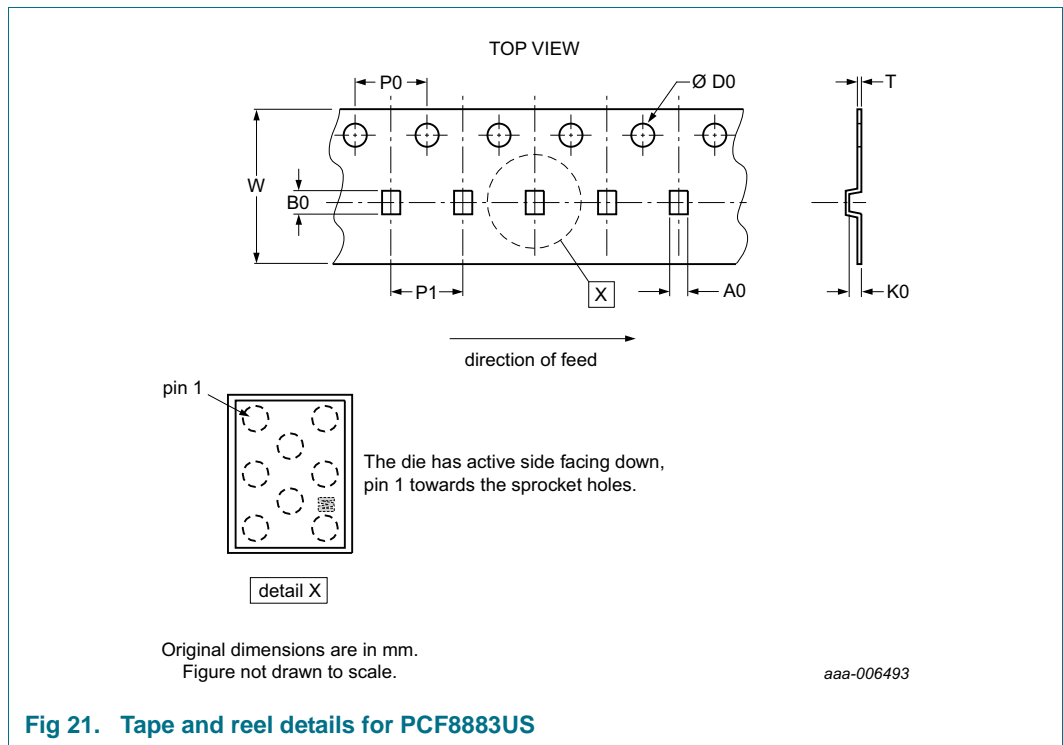

Fig 21. Tape and reel details for PCF8883US

Table 12. Carrier tape dimensions of PCF8883US

Nominal values without production tolerances.

Symbol	Description	Value	Unit
<b>Compartments</b>			
A0	pocket width in x direction	0.96	mm
B0	pocket width in y direction	1.37	mm
K0	pocket depth	0.77	mm
<b>Overall dimensions</b>			
W	tape width	8	mm
T	tape thickness	0.2	mm
D0	sprocket hole diameter	1.5	mm
P0	sprocket hole pitch	4	mm

## 19. Soldering of SMD packages

This text provides a very brief insight into a complex technology. A more in-depth account of soldering ICs can be found in Application Note *AN10365 "Surface mount reflow soldering description"*.

### 19.1 Introduction to soldering

Soldering is one of the most common methods through which packages are attached to Printed Circuit Boards (PCBs), to form electrical circuits. The soldered joint provides both the mechanical and the electrical connection. There is no single soldering method that is ideal for all IC packages. Wave soldering is often preferred when through-hole and Surface Mount Devices (SMDs) are mixed on one printed wiring board; however, it is not suitable for fine pitch SMDs. Reflow soldering is ideal for the small pitches and high densities that come with increased miniaturization.

### 19.2 Wave and reflow soldering

Wave soldering is a joining technology in which the joints are made by solder coming from a standing wave of liquid solder. The wave soldering process is suitable for the following:

- Through-hole components
- Leaded or leadless SMDs, which are glued to the surface of the printed circuit board

Not all SMDs can be wave soldered. Packages with solder balls, and some leadless packages which have solder lands underneath the body, cannot be wave soldered. Also, leaded SMDs with leads having a pitch smaller than ~0.6 mm cannot be wave soldered, due to an increased probability of bridging.

The reflow soldering process involves applying solder paste to a board, followed by component placement and exposure to a temperature profile. Leaded packages, packages with solder balls, and leadless packages are all reflow solderable.

Key characteristics in both wave and reflow soldering are:

- Board specifications, including the board finish, solder masks and vias
- Package footprints, including solder thieves and orientation
- The moisture sensitivity level of the packages
- Package placement
- Inspection and repair
- Lead-free soldering versus SnPb soldering

### 19.3 Wave soldering

Key characteristics in wave soldering are:

- Process issues, such as application of adhesive and flux, clinching of leads, board transport, the solder wave parameters, and the time during which components are exposed to the wave
- Solder bath specifications, including temperature and impurities

## 19.4 Reflow soldering

Key characteristics in reflow soldering are:

- Lead-free versus SnPb soldering; note that a lead-free reflow process usually leads to higher minimum peak temperatures (see [Figure 22](#)) than a SnPb process, thus reducing the process window
- Solder paste printing issues including smearing, release, and adjusting the process window for a mix of large and small components on one board
- Reflow temperature profile; this profile includes preheat, reflow (in which the board is heated to the peak temperature) and cooling down. It is imperative that the peak temperature is high enough for the solder to make reliable solder joints (a solder paste characteristic). In addition, the peak temperature must be low enough that the packages and/or boards are not damaged. The peak temperature of the package depends on package thickness and volume and is classified in accordance with [Table 13](#) and [14](#)

**Table 13. SnPb eutectic process (from J-STD-020D)**

Package thickness (mm)	Package reflow temperature (°C)	
	Volume (mm <sup>3</sup> )	
	< 350	≥ 350
< 2.5	235	220
≥ 2.5	220	220

**Table 14. Lead-free process (from J-STD-020D)**

Package thickness (mm)	Package reflow temperature (°C)		
	Volume (mm <sup>3</sup> )		
	< 350	350 to 2000	> 2000
< 1.6	260	260	260
1.6 to 2.5	260	250	245
> 2.5	250	245	245

Moisture sensitivity precautions, as indicated on the packing, must be respected at all times.

Studies have shown that small packages reach higher temperatures during reflow soldering, see [Figure 22](#).

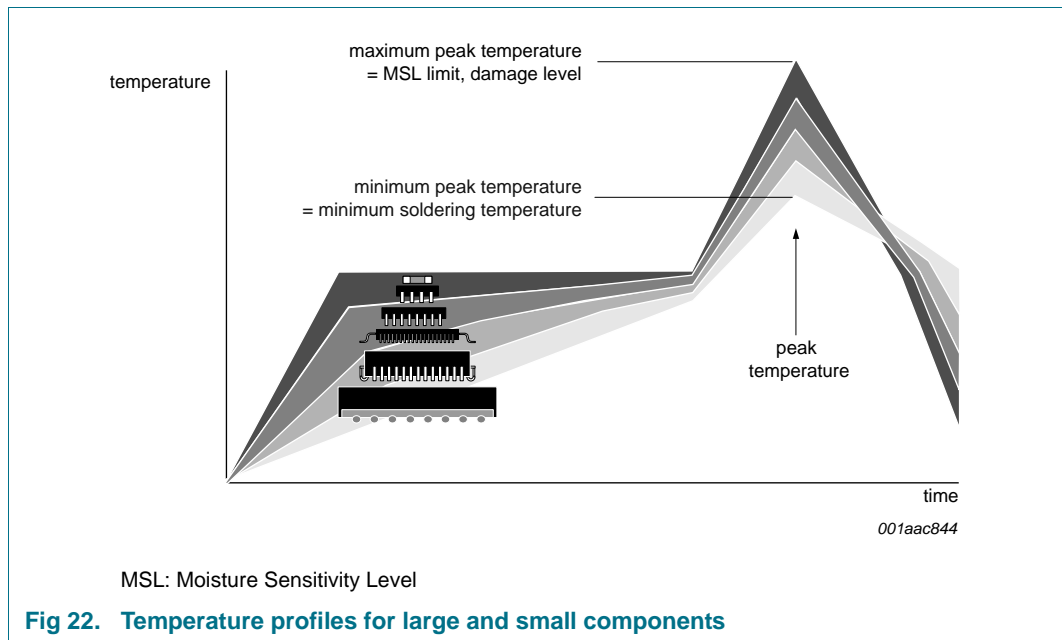

For further information on temperature profiles, refer to Application Note *AN10365* “Surface mount reflow soldering description”.

## 20. Soldering of WLCSP packages

### 20.1 Introduction to soldering WLCSP packages

This text provides a very brief insight into a complex technology. A more in-depth account of soldering WLCSP (Wafer Level Chip-Size Packages) can be found in application note *AN10439* “Wafer Level Chip Scale Package” and in application note *AN10365* “Surface mount reflow soldering description”.

Wave soldering is not suitable for this package.

All NXP WLCSP packages are lead-free.

### 20.2 Board mounting

Board mounting of a WLCSP requires several steps:

1. Solder paste printing on the PCB
2. Component placement with a pick and place machine
3. The reflow soldering itself

### 20.3 Reflow soldering

Key characteristics in reflow soldering are:

- Lead-free versus SnPb soldering; note that a lead-free reflow process usually leads to higher minimum peak temperatures (see [Figure 23](#)) than a SnPb process, thus reducing the process window

- Solder paste printing issues, such as smearing, release, and adjusting the process window for a mix of large and small components on one board
- Reflow temperature profile; this profile includes preheat, reflow (in which the board is heated to the peak temperature), and cooling down. It is imperative that the peak temperature is high enough for the solder to make reliable solder joints (a solder paste characteristic) while being low enough that the packages and/or boards are not damaged. The peak temperature of the package depends on package thickness and volume and is classified in accordance with [Table 15](#).

**Table 15. Lead-free process (from J-STD-020D)**

Package thickness (mm)	Package reflow temperature (°C)		
	Volume (mm <sup>3</sup> )		
	< 350	350 to 2000	> 2000
< 1.6	260	260	260
1.6 to 2.5	260	250	245
> 2.5	250	245	245

Moisture sensitivity precautions, as indicated on the packing, must be respected at all times.

Studies have shown that small packages reach higher temperatures during reflow soldering, see [Figure 23](#).

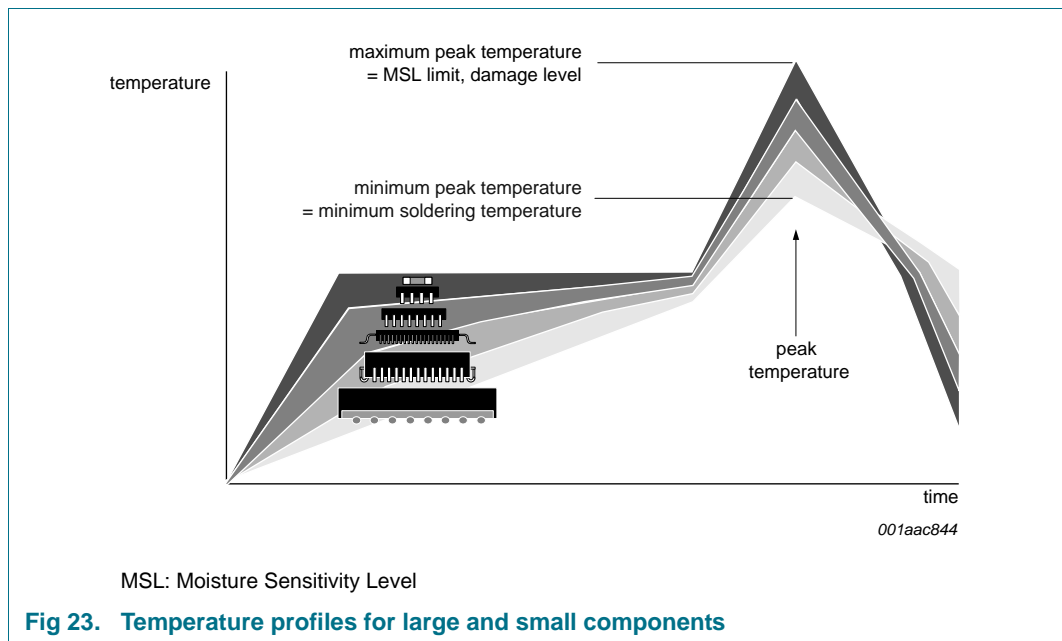

For further information on temperature profiles, refer to application note *AN10365 "Surface mount reflow soldering description"*.

**20.3.1 Stand off**

The stand off between the substrate and the chip is determined by:

- The amount of printed solder on the substrate
- The size of the solder land on the substrate

- The bump height on the chip

The higher the stand off, the better the stresses are released due to TEC (Thermal Expansion Coefficient) differences between substrate and chip.

### 20.3.2 Quality of solder joint

A flip-chip joint is considered to be a good joint when the entire solder land has been wetted by the solder from the bump. The surface of the joint should be smooth and the shape symmetrical. The soldered joints on a chip should be uniform. Voids in the bumps after reflow can occur during the reflow process in bumps with high ratio of bump diameter to bump height, i.e. low bumps with large diameter. No failures have been found to be related to these voids. Solder joint inspection after reflow can be done with X-ray to monitor defects such as bridging, open circuits and voids.

### 20.3.3 Rework

In general, rework is not recommended. By rework we mean the process of removing the chip from the substrate and replacing it with a new chip. If a chip is removed from the substrate, most solder balls of the chip will be damaged. In that case it is recommended not to re-use the chip again.

Device removal can be done when the substrate is heated until it is certain that all solder joints are molten. The chip can then be carefully removed from the substrate without damaging the tracks and solder lands on the substrate. Removing the device must be done using plastic tweezers, because metal tweezers can damage the silicon. The surface of the substrate should be carefully cleaned and all solder and flux residues and/or underfill removed. When a new chip is placed on the substrate, use the flux process instead of solder on the solder lands. Apply flux on the bumps at the chip side as well as on the solder pads on the substrate. Place and align the new chip while viewing with a microscope. To reflow the solder, use the solder profile shown in application note *AN10365 "Surface mount reflow soldering description"*.

### 20.3.4 Cleaning

Cleaning can be done after reflow soldering.

## 21. Abbreviations

Table 16. Abbreviations

Acronym	Description
CMOS	Complementary Metal Oxide Semiconductor
HBM	Human Body Model
IC	Integrated Circuit
MM	Machine Model
MOS	Metal Oxide Semiconductor
MOSFET	Metal–Oxide–Semiconductor Field-Effect Transistor
MSL	Moisture Sensitivity Level
PCB	Printed-Circuit Board
RC	Resistance-Capacitance
RF	Radio Frequency
SMD	Surface Mount Device

## 22. References

- [1] **AN10365** — Surface mount reflow soldering description
- [2] **AN10439** — Wafer Level Chip Size Package
- [3] **AN10706** — Handling bare die
- [4] **AN10832** — PCF8883 - capacitive proximity switch with auto-calibration
- [5] **AN11122** — Water and condensation safe touch sensing with the NXP capacitive touch sensors
- [6] **IEC 60134** — Rating systems for electronic tubes and valves and analogous semiconductor devices
- [7] **IEC 61340-5** — Protection of electronic devices from electrostatic phenomena
- [8] **IPC/JEDEC J-STD-020D** — Moisture/Reflow Sensitivity Classification for Nonhermetic Solid State Surface Mount Devices
- [9] **JESD22-A114** — Electrostatic Discharge (ESD) Sensitivity Testing Human Body Model (HBM)
- [10] **JESD22-A115** — Electrostatic Discharge (ESD) Sensitivity Testing Machine Model (MM)
- [11] **JESD78** — IC Latch-Up Test
- [12] **JESD625-A** — Requirements for Handling Electrostatic-Discharge-Sensitive (ESDS) Devices
- [13] **UM10370** — PCF8883 evaluation board
- [14] **UM10569** — Store and transport requirements

## 23. Revision history

Table 17. Revision history

Document ID	Release date	Data sheet status	Change notice	Supersedes
PCF8883 v.4.1	20160914	Product data sheet	-	PCF8883 v.4
Modifications:	<ul style="list-style-type: none"> <li>• <a href="#">Figure 3</a>: Clarified top/bottom view of WLCSP8</li> </ul>			
PCF8883 v.4	20140317	Product data sheet	-	PCF8883 v.3
Modifications:	<ul style="list-style-type: none"> <li>• The format of this data sheet has been redesigned to comply with the new identity guidelines of NXP Semiconductors.</li> <li>• Legal texts have been adapted to the new company name where appropriate.</li> <li>• Emphasized the X7R statement (<a href="#">Section 14</a>)</li> <li>• Added <a href="#">Section 9</a></li> <li>• Added Input or input/output statement in <a href="#">Table 4</a></li> </ul>			
PCF8883 v.3	20130423	Product data sheet	-	PCF8883 v.2
PCF8883 v.2	20110308	Product data sheet	-	PCF8883_1
PCF8883 v.1	20091016	Product data sheet	-	-

## 24. Legal information

### 24.1 Data sheet status

Document status <sup>[1][2]</sup>	Product status <sup>[3]</sup>	Definition
Objective [short] data sheet	Development	This document contains data from the objective specification for product development.
Preliminary [short] data sheet	Qualification	This document contains data from the preliminary specification.
Product [short] data sheet	Production	This document contains the product specification.

[1] Please consult the most recently issued document before initiating or completing a design.

[2] The term 'short data sheet' is explained in section "Definitions".

[3] The product status of device(s) described in this document may have changed since this document was published and may differ in case of multiple devices. The latest product status information is available on the Internet at URL <http://www.nxp.com>.

### 24.2 Definitions

**Draft** — The document is a draft version only. The content is still under internal review and subject to formal approval, which may result in modifications or additions. NXP Semiconductors does not give any representations or warranties as to the accuracy or completeness of information included herein and shall have no liability for the consequences of use of such information.

**Short data sheet** — A short data sheet is an extract from a full data sheet with the same product type number(s) and title. A short data sheet is intended for quick reference only and should not be relied upon to contain detailed and full information. For detailed and full information see the relevant full data sheet, which is available on request via the local NXP Semiconductors sales office. In case of any inconsistency or conflict with the short data sheet, the full data sheet shall prevail.

**Product specification** — The information and data provided in a Product data sheet shall define the specification of the product as agreed between NXP Semiconductors and its customer, unless NXP Semiconductors and customer have explicitly agreed otherwise in writing. In no event however, shall an agreement be valid in which the NXP Semiconductors product is deemed to offer functions and qualities beyond those described in the Product data sheet.

### 24.3 Disclaimers

**Limited warranty and liability** — Information in this document is believed to be accurate and reliable. However, NXP Semiconductors does not give any representations or warranties, expressed or implied, as to the accuracy or completeness of such information and shall have no liability for the consequences of use of such information. NXP Semiconductors takes no responsibility for the content in this document if provided by an information source outside of NXP Semiconductors.

In no event shall NXP Semiconductors be liable for any indirect, incidental, punitive, special or consequential damages (including - without limitation - lost profits, lost savings, business interruption, costs related to the removal or replacement of any products or rework charges) whether or not such damages are based on tort (including negligence), warranty, breach of contract or any other legal theory.

Notwithstanding any damages that customer might incur for any reason whatsoever, NXP Semiconductors' aggregate and cumulative liability towards customer for the products described herein shall be limited in accordance with the *Terms and conditions of commercial sale* of NXP Semiconductors.

**Right to make changes** — NXP Semiconductors reserves the right to make changes to information published in this document, including without limitation specifications and product descriptions, at any time and without notice. This document supersedes and replaces all information supplied prior to the publication hereof.

**Suitability for use** — NXP Semiconductors products are not designed, authorized or warranted to be suitable for use in life support, life-critical or safety-critical systems or equipment, nor in applications where failure or malfunction of an NXP Semiconductors product can reasonably be expected to result in personal injury, death or severe property or environmental damage. NXP Semiconductors and its suppliers accept no liability for inclusion and/or use of NXP Semiconductors products in such equipment or applications and therefore such inclusion and/or use is at the customer's own risk.

**Applications** — Applications that are described herein for any of these products are for illustrative purposes only. NXP Semiconductors makes no representation or warranty that such applications will be suitable for the specified use without further testing or modification.

Customers are responsible for the design and operation of their applications and products using NXP Semiconductors products, and NXP Semiconductors accepts no liability for any assistance with applications or customer product design. It is customer's sole responsibility to determine whether the NXP Semiconductors product is suitable and fit for the customer's applications and products planned, as well as for the planned application and use of customer's third party customer(s). Customers should provide appropriate design and operating safeguards to minimize the risks associated with their applications and products.

NXP Semiconductors does not accept any liability related to any default, damage, costs or problem which is based on any weakness or default in the customer's applications or products, or the application or use by customer's third party customer(s). Customer is responsible for doing all necessary testing for the customer's applications and products using NXP Semiconductors products in order to avoid a default of the applications and the products or of the application or use by customer's third party customer(s). NXP does not accept any liability in this respect.

**Limiting values** — Stress above one or more limiting values (as defined in the Absolute Maximum Ratings System of IEC 60134) will cause permanent damage to the device. Limiting values are stress ratings only and (proper) operation of the device at these or any other conditions above those given in the Recommended operating conditions section (if present) or the Characteristics sections of this document is not warranted. Constant or repeated exposure to limiting values will permanently and irreversibly affect the quality and reliability of the device.

**Terms and conditions of commercial sale** — NXP Semiconductors products are sold subject to the general terms and conditions of commercial sale, as published at <http://www.nxp.com/profile/terms>, unless otherwise agreed in a valid written individual agreement. In case an individual agreement is concluded only the terms and conditions of the respective agreement shall apply. NXP Semiconductors hereby expressly objects to applying the customer's general terms and conditions with regard to the purchase of NXP Semiconductors products by customer.

**No offer to sell or license** — Nothing in this document may be interpreted or construed as an offer to sell products that is open for acceptance or the grant, conveyance or implication of any license under any copyrights, patents or other industrial or intellectual property rights.

**Export control** — This document as well as the item(s) described herein may be subject to export control regulations. Export might require a prior authorization from competent authorities.

**Non-automotive qualified products** — Unless this data sheet expressly states that this specific NXP Semiconductors product is automotive qualified, the product is not suitable for automotive use. It is neither qualified nor tested in accordance with automotive testing or application requirements. NXP Semiconductors accepts no liability for inclusion and/or use of non-automotive qualified products in automotive equipment or applications.

In the event that customer uses the product for design-in and use in automotive applications to automotive specifications and standards, customer (a) shall use the product without NXP Semiconductors' warranty of the product for such automotive applications, use and specifications, and (b) whenever customer uses the product for automotive applications beyond NXP Semiconductors' specifications such use shall be solely at customer's own risk, and (c) customer fully indemnifies NXP Semiconductors for any liability, damages or failed product claims resulting from customer design and use of the product for automotive applications beyond NXP Semiconductors' standard warranty and NXP Semiconductors' product specifications.

**Translations** — A non-English (translated) version of a document is for reference only. The English version shall prevail in case of any discrepancy between the translated and English versions.

**Bare die** — All die are tested on compliance with their related technical specifications as stated in this data sheet up to the point of wafer sawing and are handled in accordance with the NXP Semiconductors storage and

transportation conditions. If there are data sheet limits not guaranteed, these will be separately indicated in the data sheet. There are no post-packing tests performed on individual die or wafers.

NXP Semiconductors has no control of third party procedures in the sawing, handling, packing or assembly of the die. Accordingly, NXP Semiconductors assumes no liability for device functionality or performance of the die or systems after third party sawing, handling, packing or assembly of the die. It is the responsibility of the customer to test and qualify their application in which the die is used.

All die sales are conditioned upon and subject to the customer entering into a written die sale agreement with NXP Semiconductors through its legal department.

## 24.4 Licenses

### ICs with capacitive sensing functionality

This NXP Semiconductors IC is made under license to European Patent No. 0723339, owned by EDISEN - SENSOR SYSTEME GmbH & CO KG and counterparts. Any license fee is included in the purchase price.

## 24.5 Trademarks

Notice: All referenced brands, product names, service names and trademarks are the property of their respective owners.

**I<sup>2</sup>C-bus** — logo is a trademark of NXP B.V.

## 25. Contact information

For more information, please visit: <http://www.nxp.com>

For sales office addresses, please send an email to: [salesaddresses@nxp.com](mailto:salesaddresses@nxp.com)

## 26. Tables

---

Table 1.	Ordering information	2
Table 2.	Ordering options	2
Table 3.	Marking codes	2
Table 4.	Pin description	5
Table 5.	Limiting values	10
Table 6.	Static characteristics	11
Table 7.	Dynamic characteristics	12
Table 8.	Dimension of PCF8883US	20
Table 9.	Solder bump locations	20
Table 10.	Alignment mark dimension and location	21
Table 11.	Carrier tape dimensions of PCF8883T	22
Table 12.	Carrier tape dimensions of PCF8883US	23
Table 13.	SnPb eutectic process (from J-STD-020D)	25
Table 14.	Lead-free process (from J-STD-020D)	25
Table 15.	Lead-free process (from J-STD-020D)	27
Table 16.	Abbreviations	29
Table 17.	Revision history	30

## 27. Figures

Fig 1.	Block diagram of PCF8883	3
Fig 2.	Pin configuration of PCF8883T (SOIC8)	4
Fig 3.	Pin configuration of PCF8883US (WLCSP8); for mechanical details, see <a href="#">Figure 18</a>	4
Fig 4.	Functional diagram of the sensor logic	6
Fig 5.	Functional principle of the PCF8883	7
Fig 6.	Switching modes timing diagram of PCF8883	9
Fig 7.	Integrated voltage regulator	9
Fig 8.	$I_{DD}$ with respect to $V_{DD}$	12
Fig 9.	$I_{DD}$ with respect to temperature	13
Fig 10.	$I_{DD}$ with respect to sampling frequency ( $f_s$ )	13
Fig 11.	Switching time ( $t_{sw}$ ) with respect to sampling frequency ( $f_s$ )	14
Fig 12.	Switching time ( $t_{sw}$ ) with respect to capacitor on pin CLIN ( $C_{CLIN}$ )	14
Fig 13.	Switching time ( $t_{sw}$ ) with respect to temperature	15
Fig 14.	Input voltage on pin CPC ( $V_{I(CPC)}$ ) with respect to capacitor on pin IN ( $C_{IN}$ )	15
Fig 15.	Input voltage on pin CPC ( $V_{I(CPC)}$ ) with respect to temperature	16
Fig 16.	Typical application	17
Fig 17.	Package outline of PCF8883T (SOIC8)	19
Fig 18.	WLCSP8 outline of PCF8883US	20
Fig 19.	Alignment mark of the PCF8883US die (for location and dimension see <a href="#">Table 10</a> )	21
Fig 20.	Tape and reel details for PCF8883T	22
Fig 21.	Tape and reel details for PCF8883US	23
Fig 22.	Temperature profiles for large and small components	26
Fig 23.	Temperature profiles for large and small components	27

## 28. Contents

<b>1</b>	<b>General description</b> . . . . .	<b>1</b>	<b>24</b>	<b>Legal information</b> . . . . .	<b>31</b>
<b>2</b>	<b>Features and benefits</b> . . . . .	<b>1</b>	24.1	Data sheet status . . . . .	31
<b>3</b>	<b>Applications</b> . . . . .	<b>1</b>	24.2	Definitions . . . . .	31
<b>4</b>	<b>Ordering information</b> . . . . .	<b>2</b>	24.3	Disclaimers . . . . .	31
4.1	Ordering options . . . . .	2	24.4	Licenses . . . . .	32
<b>5</b>	<b>Marking</b> . . . . .	<b>2</b>	24.5	Trademarks . . . . .	32
<b>6</b>	<b>Block diagram</b> . . . . .	<b>3</b>	<b>25</b>	<b>Contact information</b> . . . . .	<b>32</b>
<b>7</b>	<b>Pinning information</b> . . . . .	<b>4</b>	<b>26</b>	<b>Tables</b> . . . . .	<b>33</b>
7.1	Pinning . . . . .	4	<b>27</b>	<b>Figures</b> . . . . .	<b>34</b>
7.2	Pin description . . . . .	5	<b>28</b>	<b>Contents</b> . . . . .	<b>35</b>
<b>8</b>	<b>Functional description</b> . . . . .	<b>6</b>			
8.1	Output switching modes . . . . .	8			
8.2	Voltage regulator . . . . .	9			
<b>9</b>	<b>Safety notes</b> . . . . .	<b>10</b>			
<b>10</b>	<b>Limiting values</b> . . . . .	<b>10</b>			
<b>11</b>	<b>Static characteristics</b> . . . . .	<b>11</b>			
<b>12</b>	<b>Dynamic characteristics</b> . . . . .	<b>12</b>			
<b>13</b>	<b>Characteristic curves</b> . . . . .	<b>12</b>			
13.1	Power consumption . . . . .	12			
13.2	Typical reaction time . . . . .	14			
13.3	Reservoir capacitor voltage . . . . .	15			
<b>14</b>	<b>Application information</b> . . . . .	<b>17</b>			
<b>15</b>	<b>Package outline</b> . . . . .	<b>19</b>			
<b>16</b>	<b>Bare die outline</b> . . . . .	<b>20</b>			
<b>17</b>	<b>Handling information</b> . . . . .	<b>21</b>			
<b>18</b>	<b>Packing information</b> . . . . .	<b>22</b>			
18.1	Tape and reel information . . . . .	22			
<b>19</b>	<b>Soldering of SMD packages</b> . . . . .	<b>24</b>			
19.1	Introduction to soldering . . . . .	24			
19.2	Wave and reflow soldering . . . . .	24			
19.3	Wave soldering . . . . .	24			
19.4	Reflow soldering . . . . .	25			
<b>20</b>	<b>Soldering of WLCSP packages</b> . . . . .	<b>26</b>			
20.1	Introduction to soldering WLCSP packages . . . . .	26			
20.2	Board mounting . . . . .	26			
20.3	Reflow soldering . . . . .	26			
20.3.1	Stand off . . . . .	27			
20.3.2	Quality of solder joint . . . . .	28			
20.3.3	Rework . . . . .	28			
20.3.4	Cleaning . . . . .	28			
<b>21</b>	<b>Abbreviations</b> . . . . .	<b>29</b>			
<b>22</b>	<b>References</b> . . . . .	<b>29</b>			
<b>23</b>	<b>Revision history</b> . . . . .	<b>30</b>			

Please be aware that important notices concerning this document and the product(s) described herein, have been included in section 'Legal information'.

© NXP Semiconductors N.V. 2016.

All rights reserved.

For more information, please visit: <http://www.nxp.com>

For sales office addresses, please send an email to: [salesaddresses@nxp.com](mailto:salesaddresses@nxp.com)

Date of release: 14 September 2016

Document identifier: PCF8883

## Looking for pricing, stock, or lifecycle information?

Click below to explore more details on WIN SOURCE:

 [View PCF8883T/1,118 on WIN SOURCE](#)

 [NXP / Nexperia Information](#)

## Optimize Your Supply Chain with WIN SOURCE Solutions

-  Global Sourcing Solution
-  Obsolete Management
-  Cost Control Management
-  Shortage Management
-  Alternative Solution
-  Excess Inventory Management