



**THE DATASHEET OF
FA1004SA1-R8000**



版数 VER.	年月日 DATE	CN NO.	変更内容 DESCRIPTION	製図 DR.	担当 CHK.	査閲 APPD.	承認 APPD.
2	01/JUL/2011	072303	CHANGED APPLICABLE F.P.C DIMENSION		K. ASHIBU	T. NEMOTO	M. KIKUCHI
3	26/JUL/2011	072484	CHANGED CONNECTOR SHAPE		K. ASHIBU	T. NEMOTO	Y. YAHIRO
4	09/NOV/2011	000660	CHANGED CONNECTOR SHAPE AND APPLICABLE F.P.C DIMENSION		K. ASHIBU	T. NEMOTO	M. KIKUCHI
5	24/AUG/2012	003427	CHANGED CONNECTOR SHAPE AND APPLICABLE F.P.C AND P.C.B DIMENSION		K. ASHIBU	T. NEMOTO	M. KIKUCHI
6	07/DEC/2012	004596	ADDED NEW ITEMS etc		K. ASHIBU	T. NEMOTO	M. KIKUCHI
7	18/DEC/2012	004807	CORRECTED TABLE 2. etc		K. ASHIBU	T. NEMOTO	M. KIKUCHI

TABLE 2. DIMENSIONS

PRODUCT NO.	A	B	C	D	E	F
FA1004SA1	3.5	1.5	2.97	1.85	0.5	1.18
FA1005SA1	4.0	2.0	3.47	2.35	1.0	1.68
FA1006SA1	4.5	2.5	3.97	2.85	1.5	2.18
FA1010SA1	6.5	4.5	5.97	4.85	3.5	4.18

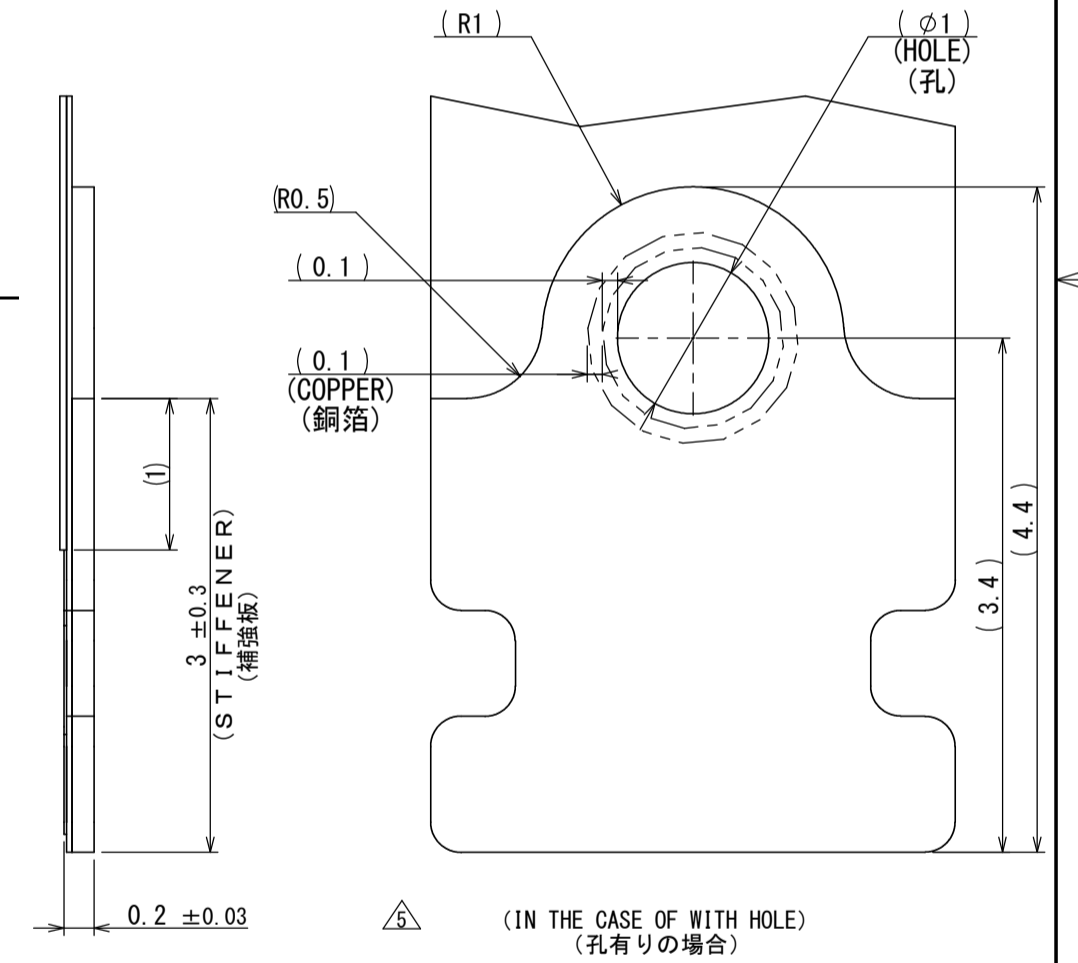
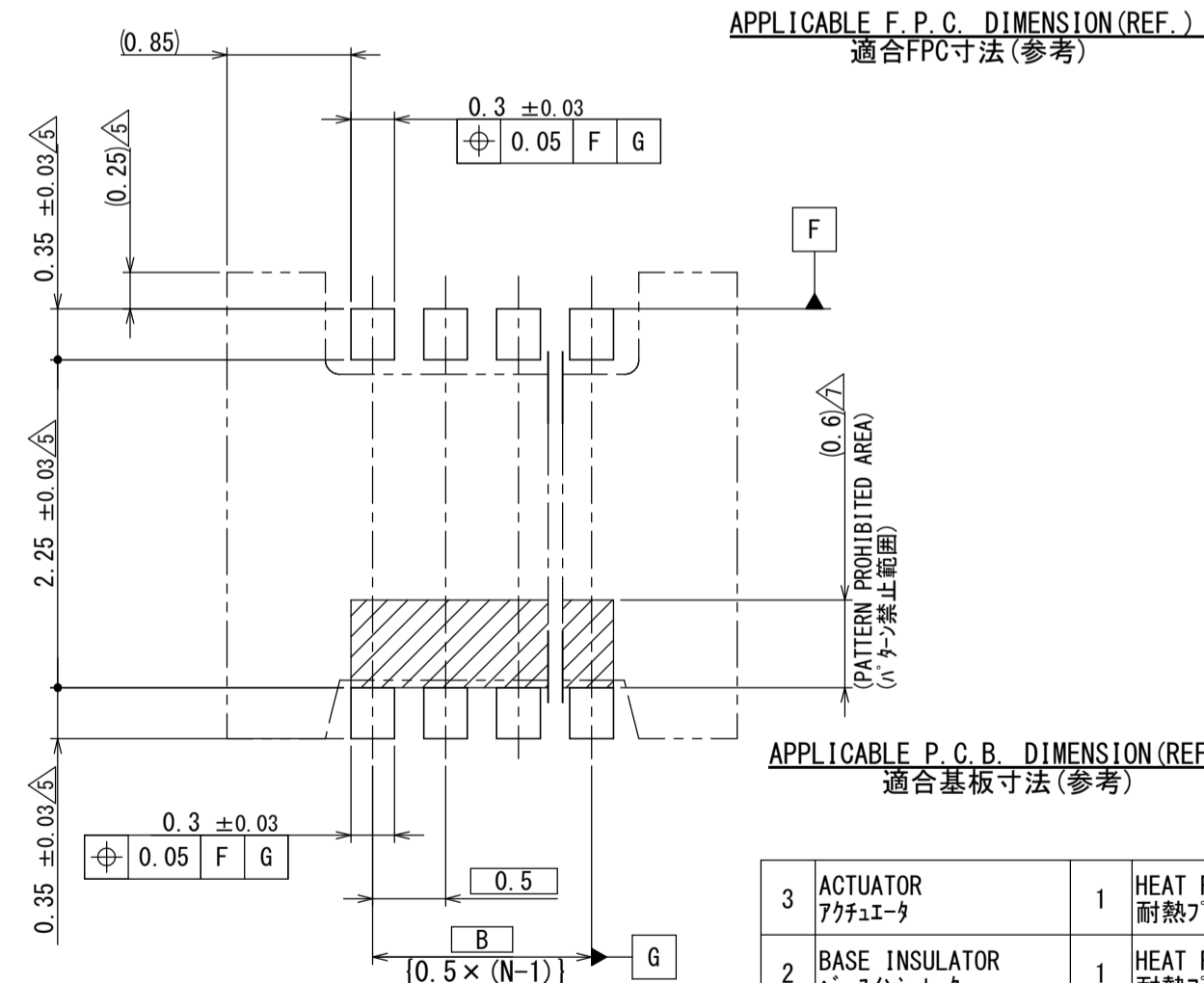
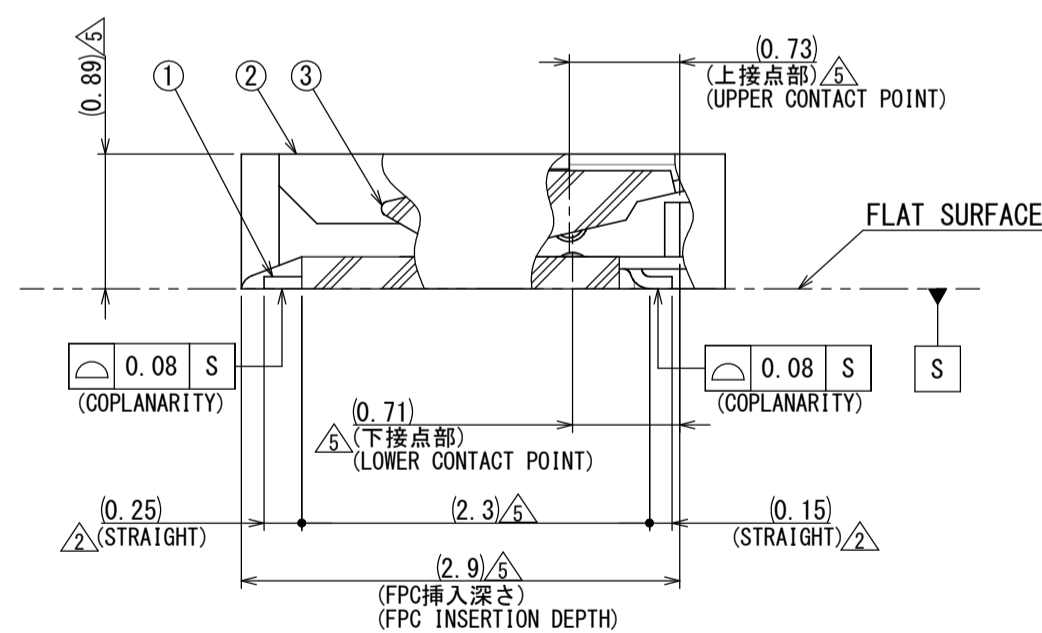
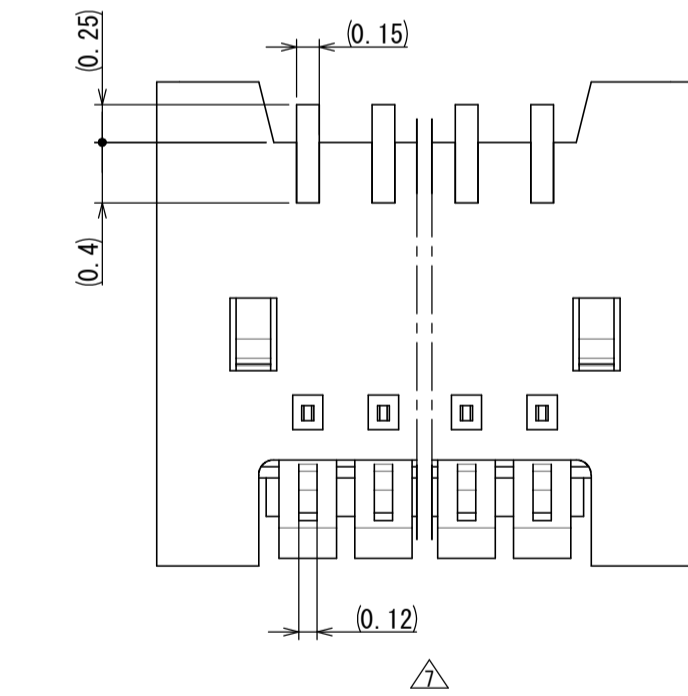
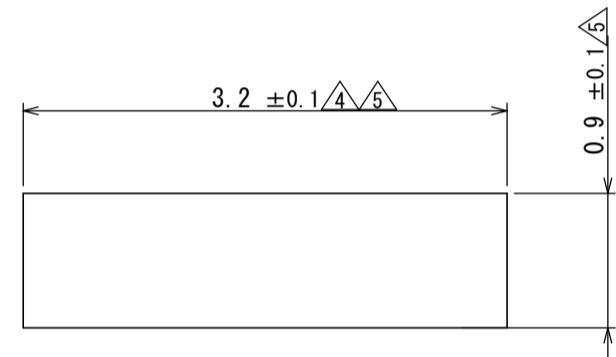
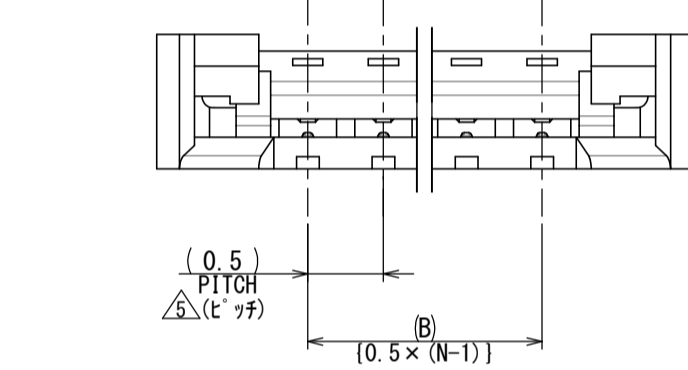
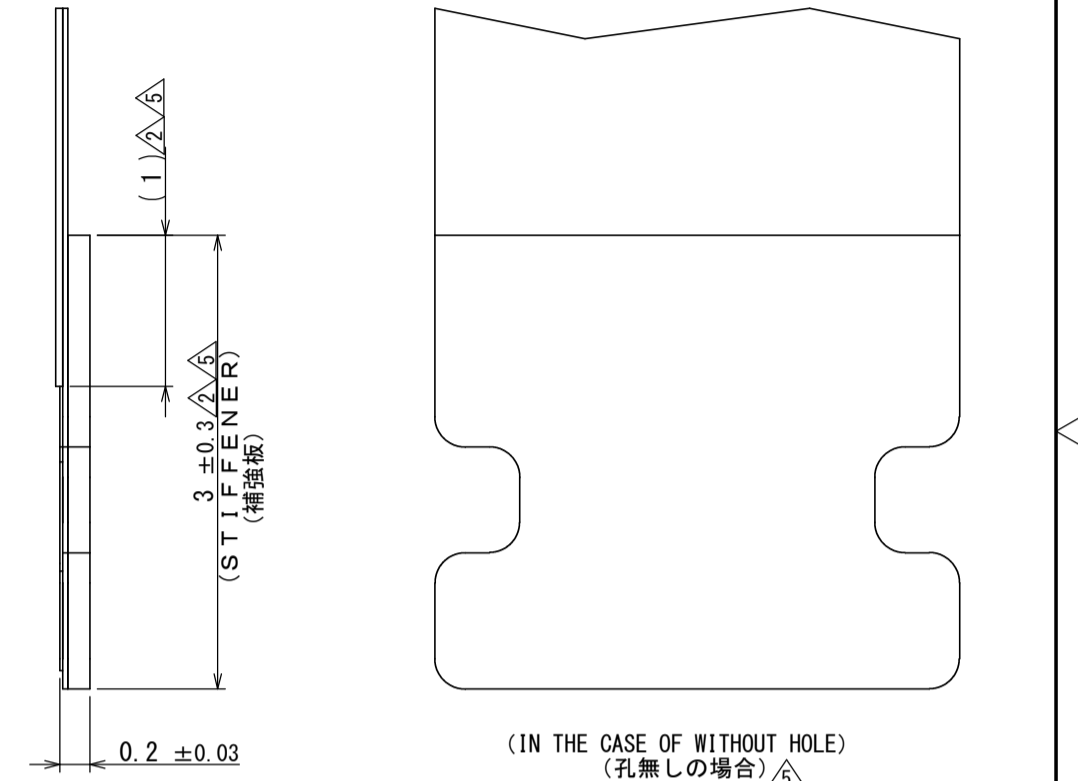
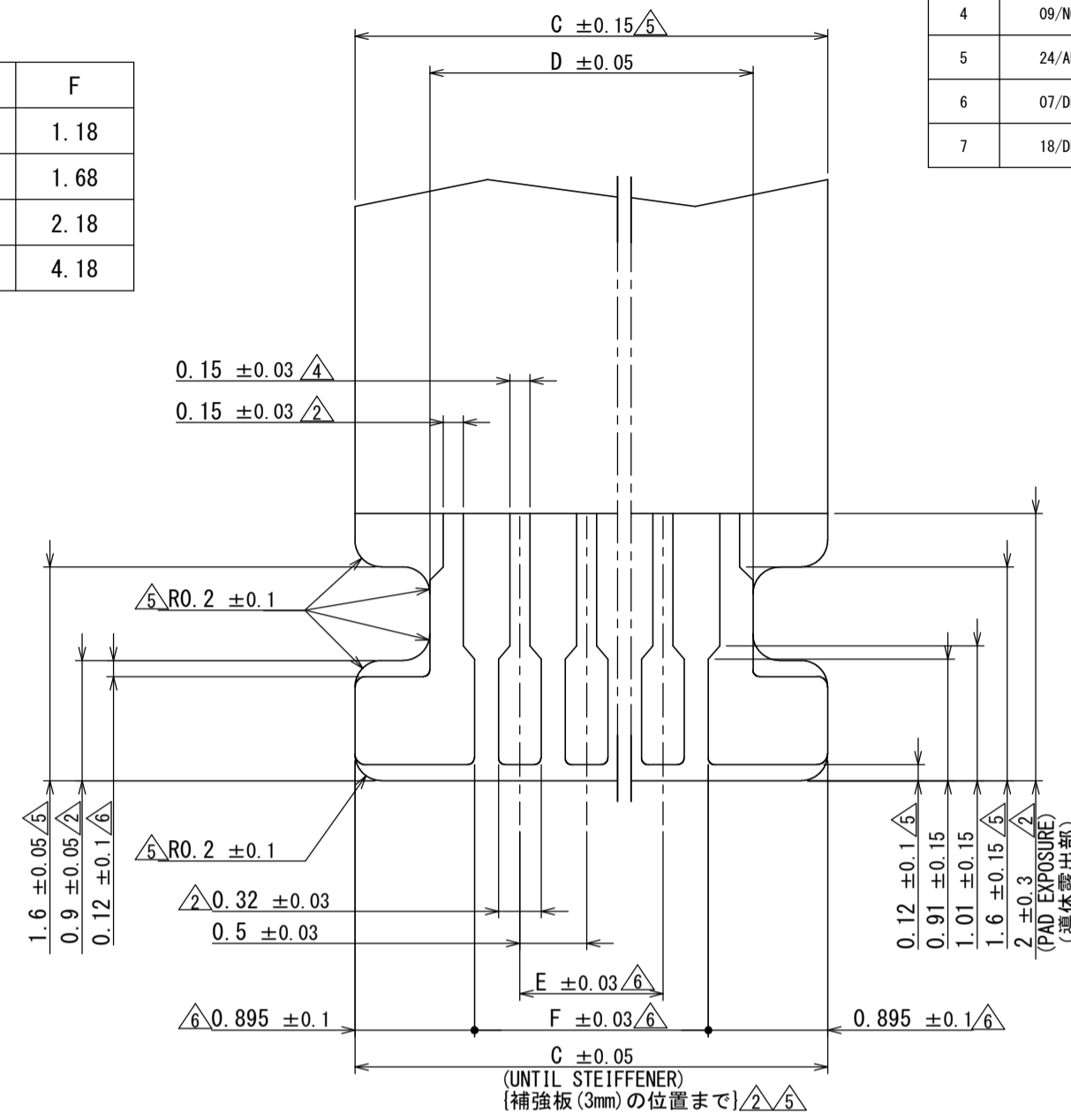
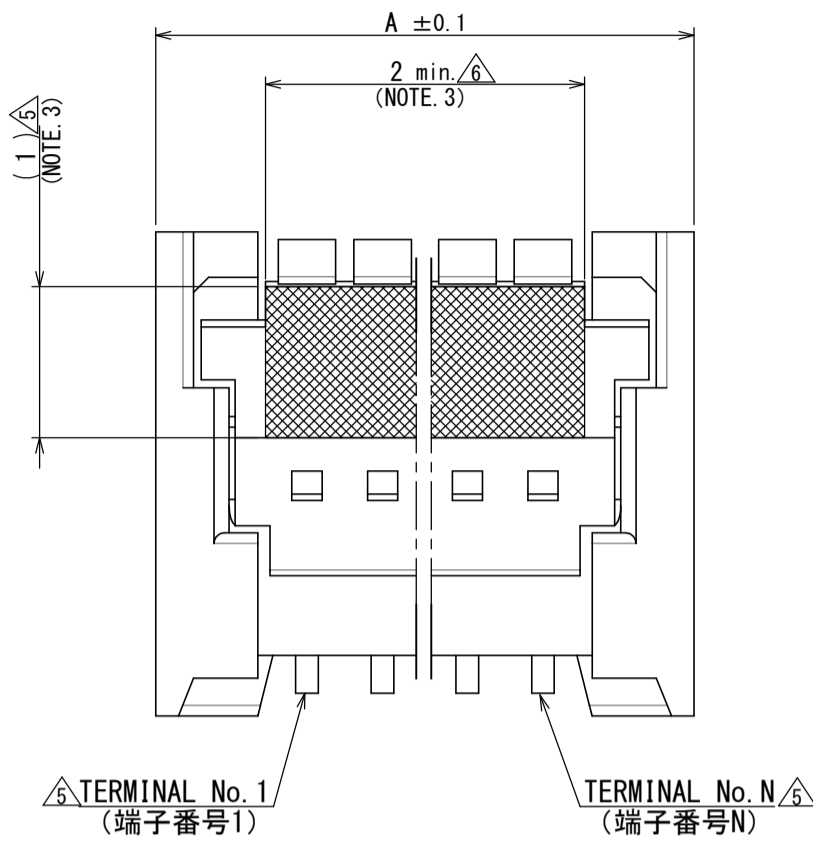

TABLE 1. RECOMMENDED F.P.C. COMPOSITION

COMPOSITION 層名	RECOMMENDED 推奨
GOLD PLATING 金めっき	ELECTROLYSIS PLATING 電解めっき 0.1 μm MIN.
COPPER 銅箔	ROLLED MATERIAL 圧延銅 18 μm MAX.
ADHESIVE 接着剤	THERMOSETTING ADHESIVE 熱硬化性 -
BASE FILM ベースフィルム	POLYIMIDE ポリイミド 25 μm
ADHESIVE 接着剤	THERMOSETTING ADHESIVE 熱硬化性 30 μm MAX.
REINFORCE PLATE 補強板	POLYIMIDE ポリイミド -

- NOTE
- REFER TO TABLE1 FOR RECOMMENDED FPC COMPOSITION.
 - A NICKEL BARRIER EXISTS BETWEEN CONTACT POINT AND TAIL.
 - THE DIMENSIONS OF VACUUMING COVER AREA.
 - RECOMMENDED F.P.C. PUNCHER DIRECTION ARE FROM CONDUCTOR SIDE TO STIFFNER FILME SIDE.
 - CAVITY AND LOT NUMBER IS MARKED ON THE TOP PORTION OF THE CONNECTOR.
 - THIS PRODUCT IS HALOGEN-FREE

- 注記
- 推奨FPC構成はTABLE1参照のこと。
 - コンタクト接点とSMT部の間にはニッケルバリアがあります。
 - 吸着エリアを示す。
 - FPC抜き方向は、導体側から補強板側を推奨します。
 - キャビティおよびロット番号がコネクタ上面に表記されます。
 - 本製品はハロゲンフリー品です。

符号 NO.	名称 DESCRIPTION	個数 QTY.	材料 MATERIAL	仕上 FINISH	備考 REMARKS
3	ACTUATOR アクチュエータ	1	HEAT RESISTING PLASTICS 耐熱プラスチック		COLOR : BLACK/色相 : 黒色 UL94V-0
2	BASE INSULATOR ベースインシュレータ	1	HEAT RESISTING PLASTICS 耐熱プラスチック		COLOR : BLACK/色相 : 黒色 UL94V-0
1	CONTACT コンタクト	N	COPPER ALLOY 銅合金	PARIAL GOLD(0.1 μm MIN.) OVER NICKEL ニッケル上部分Au 0.1 μm以上	

仕様書(SPECIFICATION) JACS-10931-*(2/5) JAHL-10931	第1版(ORIGINAL DATE) 01/APR/2011	尺度(SCALE) 1:5	シリーズ(SERIES) FA10	日本航空電子工業株式会社
一般公差(GENERAL TOLERANCE) 寸法(DIMENSION): ±0.8 × ±0.4 ×× ±0.1 ××× ±	角度(ANGLES): ×° ± ××' ±	製図 DR.	名称(TITLE) FA10**SA1	JAE JAPAN AVIATION ELECTRONICS INDUSTRY, LTD.
担当 CHK. 査閲 APPD.	K. ASHIBU	承認 APPD.	M. KIKUCHI	図面番号(DRAWING NO.) SJ111450
質量(MASS)				版数(VER.) 7

SJ111451
 (DRAWING NO.)

版数 VER.	年月日 DATE	CN NO.	変更内容 DESCRIPTION	製図 DR.	担当 CHK.	査閲 APPD.	承認 APPD.
2	09/NOV/2011	000660	CHANGED DIMENSIONS		K. ASHIBU	T. NEMOTO	M. KIKUCHI
3	24/AUG/2012	003427	CHANGED THE PART NUMBER		K. ASHIBU	T. NEMOTO	M. KIKUCHI
4	20/DEC/2012	004596	ADDED NEW ITEMS		K. ASHIBU	T. NEMOTO	M. KIKUCHI

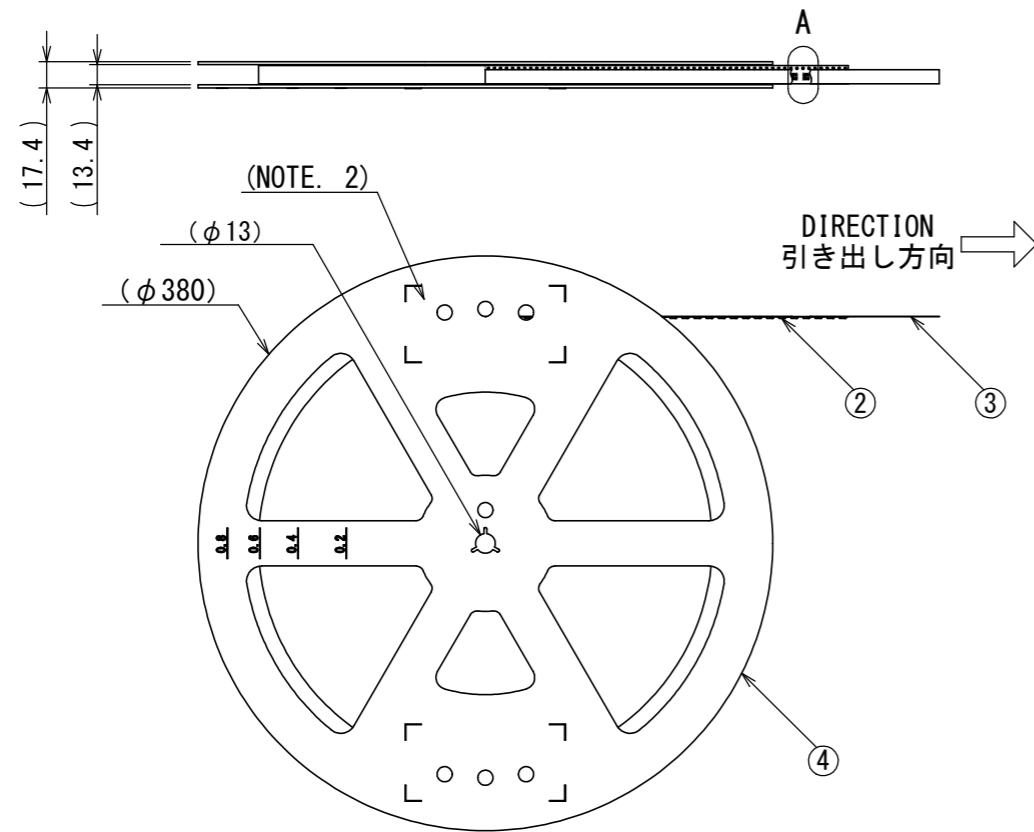
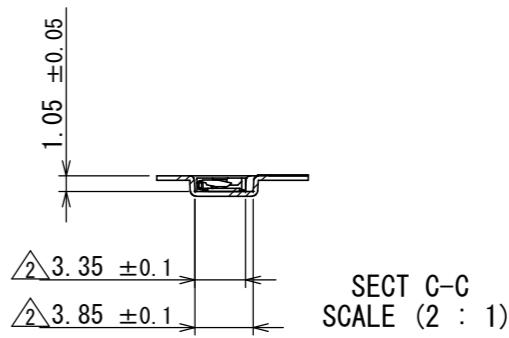
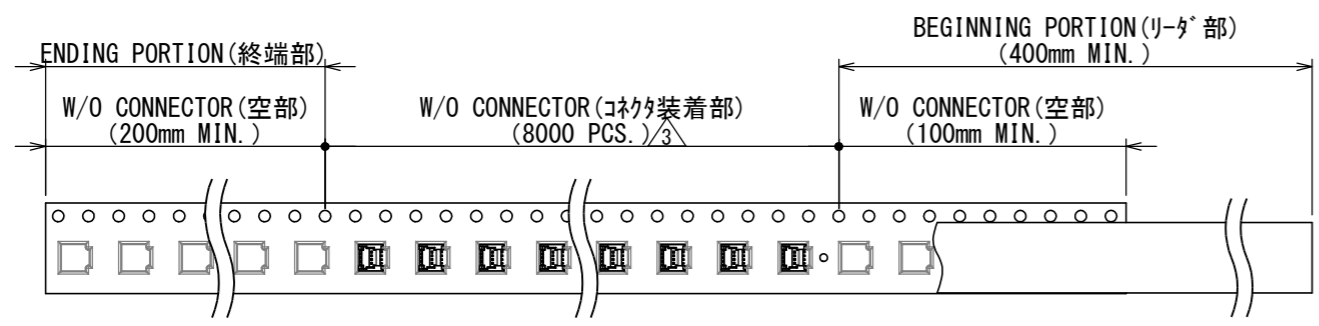
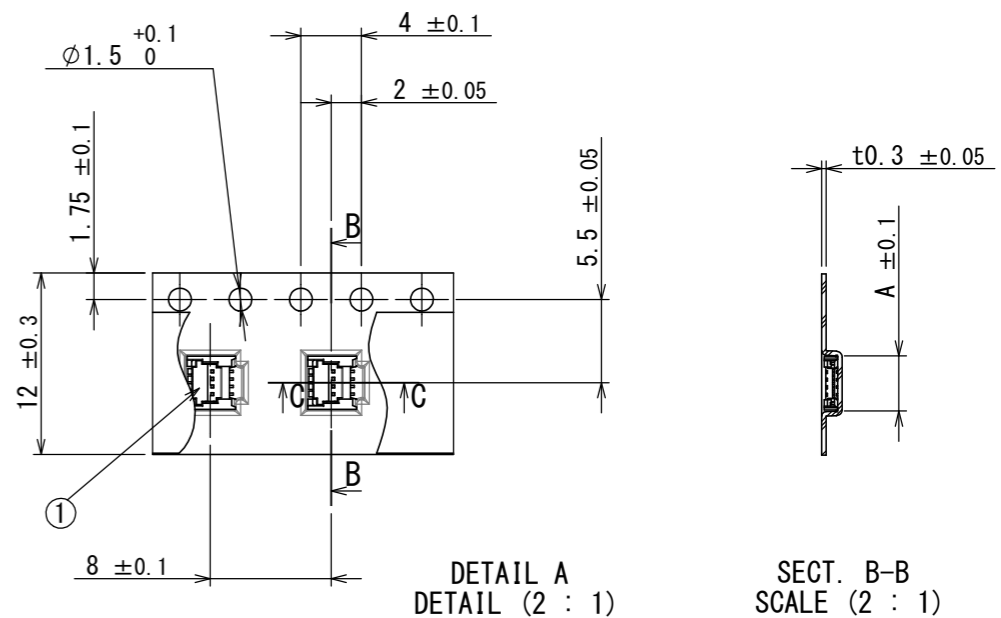

TABLE1. DIMENSION Δ

PRODUCT NO.	A
FA1004SA1	3.65
FA1005SA1	4.15
FA1006SA1	4.65
FA1010SA1	6.65



Δ NOTE1. SUFFIX "FA10**SA1-R8000" OF THE PART NUMBER INDICATES THAT 8000 PCS. OF FA10**SA1-R8000 CONNECTORS.
 2. THE LABEL IN WHICH PART NO., NUMBER OF CONNECTORS, LOT NO., TAPE WIDTH AND FEED PITCH ARE MARKED IS ATTACHED.
 3. REFER TO THE DRAWING, SJ111450 (TITLE: FA10**SA1)

Δ 注1. "FA10**SA1-R8000"は収納数8000個入りのリールに収納された品名を表す。
 2. 図示の位置にシールを貼り、品名、収納数、ロットNo. 及び、テープの幅と送りピッチを記入すること。
 3. コネクタ寸法はSJ111450 (FA10**SA1) 参照。

符号 No.	名称 DESCRIPTION	個数 QTY.	材料 MATERIAL	仕上 FINISH	備考 REMARKS
4	PLASTIC REEL プラスチックリール	1	PS	-	-
3	COVER TAPE カバーテープ	1	POLYESTER ポリエステル	-	-
2	CARRIER TAPE キャリアテープ	1	ANTI-STATIC CHARGE PS 帯電防止PS	-	Δ 2
1	CONNECTOR コネクタ	8000 Δ 3	-	-	FA10**SA1 (SJ111450)

仕様書 (SPECIFICATION)		第1版 (ORIGINAL DATE) 01/APR/2011	尺度 (SCALE) 1:5	シリーズ (SERIES) FA10	日本航空電子工業株式会社
一般公差 (GENERAL TOLERANCE)		製図 DR.	名称 (TITLE) FA10**SA1-R8000 Δ 3		JAE JAPAN AVIATION ELECTRONICS INDUSTRY, LTD.
寸法 (DIMENSION)	角度 (ANGLES)	担当 CHK. K. ASHIBU	質量 (MASS)		
±0.8	×° ±	査閲 APPD.	図面番号 (DRAWING NO.) SJ111451		版数 (VER.) 4
× ±0.4	××° ±	承認 APPD. M. KIKUCHI	質量 (MASS)		
×× ±0.1	単位 (UNIT) : mm		質量 (MASS)		
××× ±			質量 (MASS)		

DCF-G-212H(12.08)

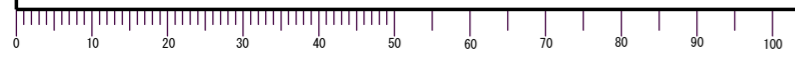

WISDOM承認 2012/12/12

Looking for pricing, stock, or lifecycle information?

Click below to explore more details on WIN SOURCE:

 [View FA1004SA1-R8000](#) on WIN SOURCE

 [JAE Electronics](#) Information

Optimize Your Supply Chain with WIN SOURCE Solutions

-  Global Sourcing Solution
-  Obsolete Management
-  Cost Control Management
-  Shortage Management
-  Alternative Solution
-  Excess Inventory Management