

FEATURES

- 18-bit resolution with no missing codes
- No pipeline delay (SAR architecture)
- Differential input range: $\pm V_{REF}$ (V_{REF} up to 5 V)
- Throughput
 - 800 kSPS (warp mode)
 - 666 kSPS (normal mode)
 - 570 kSPS (impulse mode)
- INL: ± 2.5 LSB max (± 9.5 ppm of full scale)
- Dynamic range : 103 dB typ ($V_{REF} = 5$ V)
- SINAD: 100 dB typ at 2 kHz ($V_{REF} = 5$ V)
- Parallel (18-, 16-, or 8-bit bus) and serial 5 V/3 V interface
- SPI/QSPI™/MICROWIRE/DSP compatible
- On-board reference buffer
- Single 5 V supply operation
- Power dissipation
 - 98 mW typ at 800 kSPS
 - 78 mW typ at 500 kSPS (impulse mode)
 - 160 μ W at 1 kSPS (impulse mode)
- 48-lead LQFP or 48-lead LFCSP
- Pin-to-pin compatible upgrade of [AD7676](#), [AD7678](#), and [AD7679](#)

APPLICATIONS

- CT scanners
- High dynamic data acquisition
- Geophone and hydrophone sensors
- Σ - Δ replacement (low power, multichannel)
- Instrumentation
- Spectrum analysis
- Medical instruments

GENERAL DESCRIPTION

The [AD7674](#) is an 18-bit, 800 kSPS, charge redistribution, successive approximation register (SAR) fully differential analog-to-digital converter (ADC) that operates on a single 5 V power supply. The device contains a high speed, 18-bit sampling ADC, an internal conversion clock, an internal reference buffer, error correction circuits, and both serial and parallel system interface ports.

The device is available in a 48-lead LQFP or a 48-lead LFCSP with operation specified from -40°C to $+85^{\circ}\text{C}$.

FUNCTIONAL BLOCK DIAGRAM

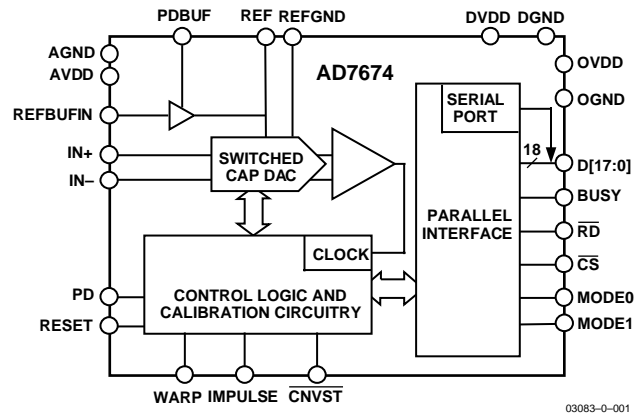

Figure 1.

Table 1. PulSAR™ Selection

Type	100 kSPS to 250 kSPS	500 kSPS to 570 kSPS	800 kSPS to 1000 kSPS
Pseudo-Differential	AD7651 , AD7660 / AD7661	AD7650 / AD7652 , AD7664 / AD7666	AD7653 , AD7667
True Bipolar	AD7663	AD7665	AD7671
True Differential	AD7675	AD7676	AD7677
18-Bit	AD7678	AD7679	AD7674
Multichannel/ Simultaneous		AD7654 , AD7655	

PRODUCT HIGHLIGHTS

1. High Resolution, Fast Throughput. The [AD7674](#) is an 800 kSPS, charge redistribution, 18-bit, SAR ADC (no latency).
2. Excellent Accuracy. The [AD7674](#) has a maximum integral nonlinearity of 2.5 LSB with no missing 18-bit codes.
3. Serial or Parallel Interface. Versatile parallel (18-, 16- or 8-bit bus) or 3-wire serial interface arrangement compatible with both 3 V and 5 V logic.

TABLE OF CONTENTS

Features	1	Converter Operation.....	16
Applications.....	1	Typical Connection Diagram	17
General Description	1	Power Dissipation versus Throughput	20
Functional Block Diagram	1	Conversion Control	20
Product Highlights	1	Digital Interface	20
Table of Contents	2	Parallel Interface	21
Revision History	2	Serial Interface	21
Specifications.....	3	Master Serial Interface	21
Timing Specifications	5	Slave Serial Interface	23
Absolute Maximum Ratings.....	7	Microprocessor Interfacing.....	24
ESD Caution.....	7	Applications Information	25
Pin Configuration and Function Descriptions.....	8	Layout	25
Terminology	11	Evaluating AD7674 Performance.....	25
Typical Performance Characteristics	12	Outline Dimensions	26
Circuit Information.....	16	Ordering Guide	26

REVISION HISTORY

6/2016—Rev. A to Rev. B

Changed CP-48-1 to CP-48-4 and ADSP-219x to ADSP-2191M	Throughout
Changes to Figure 4 and Table 6.....	8
Added Figure 5; Renumbered Sequentially	8
Changes to Serial Peripheral Interface (SPI) Section.....	24
Updated Outline Dimensions	26
Changes to Ordering Guide	26

6/2009—Rev. 0 to Rev. A

Changes to Zero Error, T_{MIN} to T_{MAX} Parameter.....	3
Changes to Gain Error, T_{MIN} to T_{MAX} Parameter.....	3
Changes to Endnote 3	4
Changes to Pin Configuration Section	8
Changes to Evaluating the AD7674's Performance Section.....	25
Changes to Ordering Guide	26

7/2003—Revision 0: Initial Version

SPECIFICATIONS

–40°C to +85°C, $V_{REF} = 4.096\text{ V}$, $AVDD = DVDD = 5\text{ V}$, $OVDD = 2.7\text{ V}$ to 5.25 V , unless otherwise noted.

Table 2.

Parameter	Test Conditions/Comments	Min	Typ	Max	Unit
RESOLUTION		18			Bits
ANALOG INPUT					
Voltage Range	$V_{IN+} - V_{IN-}$	$-V_{REF}$		$+V_{REF}$	V
Operating Input Voltage	V_{IN+} , V_{IN-} to AGND	–0.1		AVDD	V
Analog Input CMRR	$f_{IN} = 100\text{ kHz}$		65		dB
Input Current	800 kSPS throughput		100		μA
Input Impedance ¹					
THROUGHPUT SPEED					
Complete Cycle	In warp mode			1.25	μs
Throughput Rate	In warp mode	1		800	kSPS
Time Between Conversions	In warp mode			1	ms
Complete Cycle	In normal mode			1.5	μs
Throughput Rate	In normal mode	0		666	kSPS
Complete Cycle	In impulse mode			1.75	μs
Throughput Rate	In impulse mode	0		570	kSPS
DC ACCURACY					
Integral Linearity Error		–2.5		+2.5	LSB ²
Differential Linearity Error		–1		+1.75	LSB
No Missing Codes		18			Bits
Transition Noise	$V_{REF} = 5\text{ V}$		0.7		LSB
Zero Error, T_{MIN} to T_{MAX}	In warp mode	–25		+25	LSB
Zero Error, T_{MIN} to T_{MAX}	In normal mode or impulse mode	–85		+85	LSB
Zero Error Temperature Drift	All modes		± 0.5		ppm/°C
Gain Error, T_{MIN} to T_{MAX} ³	In warp mode	–0.034		+0.034	% of FSR
Gain Error, T_{MIN} to T_{MAX} ³	In normal mode or impulse mode	–0.048		+0.048	% of FSR
Gain Error Temperature Drift	All modes		± 1.6		ppm/°C
Power Supply Sensitivity	$AVDD = 5\text{ V} \pm 5\%$		± 4		LSB
AC ACCURACY					
Signal-to-Noise	$f_{IN} = 2\text{ kHz}$, $V_{REF} = 5\text{ V}$ $V_{REF} = 4.096\text{ V}$	97.5	101		dB ⁴
	$f_{IN} = 10\text{ kHz}$, $V_{REF} = 4.096\text{ V}$		98		dB
	$f_{IN} = 100\text{ kHz}$, $V_{REF} = 4.096\text{ V}$		97		dB
Dynamic Range	$V_{IN+} = V_{IN-} = V_{REF}/2 = 2.5\text{ V}$		103		dB
Spurious-Free Dynamic Range	$f_{IN} = 2\text{ kHz}$		120		dB
	$f_{IN} = 10\text{ kHz}$		118		dB
	$f_{IN} = 100\text{ kHz}$		105		dB
Total Harmonic Distortion	$f_{IN} = 2\text{ kHz}$		–115		dB
	$f_{IN} = 10\text{ kHz}$		–113		dB
	$f_{IN} = 100\text{ kHz}$		–98		dB
Signal-to-Noise-and-Distortion Ratio	$f_{IN} = 2\text{ kHz}$, $V_{REF} = 4.096\text{ V}$		98		dB
	$f_{IN} = 2\text{ kHz}$, –60 dB input		40		dB
–3 dB Input Bandwidth			26		MHz
SAMPLING DYNAMICS					
Aperture Delay			2		ns
Aperture Jitter			5		ps rms
Transient Response	Full-scale step			250	ns
Overvoltage Recovery				250	ns

Parameter	Test Conditions/Comments	Min	Typ	Max	Unit
REFERENCE					
External Reference Voltage Range	REF	3	4.096	AVDD + 0.1	V
REF Voltage with Reference Buffer	REFBUFIN = 2.5 V	4.05	4.096	4.15	V
Reference Buffer Input Voltage Range	REFBUFIN	1.8	2.5	2.6	V
REFBUFIN Input Current		-1		+1	μA
REF Current Drain	800 kSPS throughput		330		μA
DIGITAL INPUTS					
Logic Levels					
V _{IL}		-0.3		+0.8	V
V _{IH}		+2.0		DVDD + 0.3	V
I _{IL}		-1		+1	μA
I _{IH}		-1		+1	μA
DIGITAL OUTPUTS					
Data Format ⁵					
Pipeline Delay ⁶					
V _{OL}	I _{SINK} = 1.6 mA			0.4	V
V _{OH}	I _{SOURCE} = -500 μA	OVDD - 0.6			V
POWER SUPPLIES					
Specified Performance					
AVDD		4.75	5	5.25	V
DVDD		4.75	5	5.25	V
OVDD		2.7		DVDD + 0.3 ⁷	V
Operating Current ⁸					
AVDD	800 kSPS throughput		16		mA
DVDD ⁹			6.5		mA
OVDD ⁹			50		μA
POWER DISSIPATION⁹					
	PDBUF high at 500 kSPS ¹⁰		78	90	mW
	PDBUF high at 1 kSPS ¹⁰		160		μW
	PDBUF high at 800 kSPS ⁸		114	126	mW
	PDBUF low at 800 kSPS ⁸		126	138	mW
TEMPERATURE RANGE¹¹					
Specified Performance					
	T _{MIN} to T _{MAX}	-40		+85	°C

¹ See the Analog Inputs section.

² LSB means least significant bit. With the ±4.096 V input range, 1 LSB is 31.25 μV.

³ See the Terminology section. The nominal gain error is not centered at zero and is -0.029% of FSR. This specification is the deviation from this nominal value. These specifications do not include the error contribution from the external reference, but do include the error contribution from the reference buffer if used.

⁴ All specifications in dB are referred to a full-scale input, FS. Tested with an input signal at 0.5 dB below full scale unless otherwise specified.

⁵ Data format parallel or serial 18-bit.

⁶ Conversion results are available immediately after completed conversion.

⁷ The max should be the minimum of 5.25 V and DVDD + 0.3 V.

⁸ In warp mode.

⁹ Tested in parallel reading mode.

¹⁰ In impulse mode.

¹¹ Contact factory for extended temperature range.

TIMING SPECIFICATIONS

–40°C to +85°C, AVDD = DVDD = 5 V, OVDD = 2.7 V to 5.25 V, unless otherwise noted.

Table 3.

Parameter	Symbol	Min	Typ	Max	Unit
Refer to Figure 35 and Figure 36					
Convert Pulse Width	t ₁	10			ns
Time Between Conversions (Warp Mode/Normal Mode/Impulse Mode) ¹	t ₂	1.25/1.5/1.75			μs
CNVST Low to BUSY High Delay	t ₃			35	ns
BUSY High All Modes Except Master Serial Read After Convert (Warp Mode/Normal Mode/Impulse Mode)	t ₄			1/1.25/1.5	μs
Aperture Delay	t ₅		2		ns
End of Conversion to BUSY Low Delay	t ₆	10			ns
Conversion Time (Warp Mode/Normal Mode/Impulse Mode)	t ₇			1/1.25/1.5	μs
Acquisition Time	t ₈	250			ns
RESET Pulse Width	t ₉	10			ns
Refer to Figure 37, Figure 38, and Figure 39 (Parallel Interface Modes)					
CNVST Low to Data Valid Delay (Warp Mode/Normal Mode/Impulse Mode)	t ₁₀			1/1.25/1.5	μs
Data Valid to BUSY Low Delay	t ₁₁	20			ns
Bus Access Request to Data Valid	t ₁₂			45	ns
Bus Relinquish Time	t ₁₃	5		15	ns
Refer to Figure 41 and Figure 42 (Master Serial Interface Modes) ²					
$\overline{\text{CS}}$ Low to SYNC Valid Delay	t ₁₄			10	ns
$\overline{\text{CS}}$ Low to Internal SCLK Valid Delay	t ₁₅			10	ns
$\overline{\text{CS}}$ Low to SDOUT Delay	t ₁₆			10	ns
CNVST Low to SYNC Delay (Warp Mode/Normal Mode/Impulse Mode)	t ₁₇		25/275/525		ns
SYNC Asserted to SCLK First Edge Delay ³	t ₁₈	3			ns
Internal SCLK Period ³	t ₁₉	25		40	ns
Internal SCLK High ³	t ₂₀	12			ns
Internal SCLK Low ³	t ₂₁	7			ns
SDOUT Valid Setup Time ³	t ₂₂	4			ns
SDOUT Valid Hold Time ³	t ₂₃	2			ns
SCLK Last Edge to SYNC Delay ³	t ₂₄	3			ns
$\overline{\text{CS}}$ High to SYNC High-Z	t ₂₅			10	ns
$\overline{\text{CS}}$ High to Internal SCLK High-Z	t ₂₆			10	ns
$\overline{\text{CS}}$ High to SDOUT High-Z	t ₂₇			10	ns
BUSY High in Master Serial Read After Convert ³	t ₂₈		Table 4		
CNVST Low to SYNC Asserted Delay (Warp Mode/Normal Mode/Impulse Mode)	t ₂₉		1/1.25/1.5		μs
SYNC Deasserted to BUSY Low Delay	t ₃₀		25		ns
Refer to Figure 43 and Figure 44 (Slave Serial Interface Modes)					
External SCLK Setup Time	t ₃₁	5			ns
External SCLK Active Edge to SDOUT Delay	t ₃₂	3		18	ns
SDIN Setup Time	t ₃₃	5			ns
SDIN Hold Time	t ₃₄	5			ns
External SCLK Period	t ₃₅	25			ns
External SCLK High	t ₃₆	10			ns
External SCLK Low	t ₃₇	10			ns

¹In warp mode only, the maximum time between conversions is 1 ms; otherwise, there is no required maximum time.

²In serial interface modes, the SYNC, SCLK, and SDOUT timings are defined with a maximum load C_L of 10 pF; otherwise, the load is 60 pF maximum.

³In serial master read during convert mode. See Table 4 for serial master read after convert mode.

Table 4. Serial Clock Timings in Master Read After Convert

DIVSCLK[1]		0	0	1	1		
DIVSCLK[0]	Symbol	0	1	0	1	Unit	
	SYNC to SCLK First Edge Delay Minimum	t ₁₈	3	17	17	17	ns
	Internal SCLK Period Minimum	t ₁₉	25	60	120	240	ns
	Internal SCLK Period Maximum	t ₁₉	40	80	160	320	ns
	Internal SCLK High Minimum	t ₂₀	12	22	50	100	ns
	Internal SCLK Low Minimum	t ₂₁	7	21	49	99	ns
	SDOUT Valid Setup Time Minimum	t ₂₂	4	18	18	18	ns
	SDOUT Valid Hold Time Minimum	t ₂₃	2	4	30	89	ns
	SCLK Last Edge to SYNC Delay Minimum	t ₂₄	3	60	140	300	ns
	BUSY High Width Maximum (Warp Mode)	t ₂₈	1.75	2.5	4	7	μs
	BUSY High Width Maximum (Normal Mode)	t ₂₈	2	2.75	4.25	7.25	μs
	BUSY High Width Maximum (Impulse Mode)	t ₂₈	2.25	3	4.5	7.5	μs

ABSOLUTE MAXIMUM RATINGS

Table 5. AD7674 Absolute Maximum Ratings

Parameter	Rating
Analog Inputs IN+ ¹ , IN- ¹ , REF, REFBUFIN, REFGND to AGND	AGND - 0.3 V to AVDD + 0.3 V
Ground Voltage Differences AGND, DGND, OGND	±0.3 V
Supply Voltages AVDD, DVDD, OVDD	-0.3 V to +7 V
AVDD to DVDD, AVDD to OVDD	±7 V
DVDD to OVDD	-0.3 V to +7 V
Digital Inputs	-0.3 V to DVDD + 0.3 V
Internal Power Dissipation ²	700 mW
Internal Power Dissipation ³	2.5 W
Junction Temperature	150°C
Storage Temperature Range	-65°C to +150°C
Lead Temperature Range (Soldering 10 sec)	300°C

¹See the Analog Inputs section.

²Specification is for device in free air: 48-Lead LQFP: $\theta_{JA} = 91^\circ\text{C}/\text{W}$,
 $\theta_{JC} = 30^\circ\text{C}/\text{W}$.

³ Specification is for device in free air: 48-Lead LFCSP: $\theta_{JA} = 26^\circ\text{C}/\text{W}$.

Stresses at or above those listed under Absolute Maximum Ratings may cause permanent damage to the product. This is a stress rating only; functional operation of the product at these or any other conditions above those indicated in the operational section of this specification is not implied. Operation beyond the maximum operating conditions for extended periods may affect product reliability.

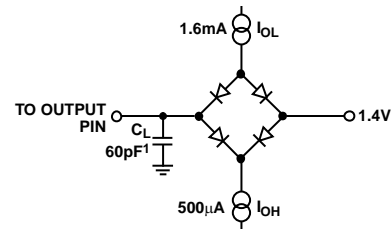

NOTE
1 IN SERIAL INTERFACE MODES, THE SYNC, SCLK, AND SDOU TIMINGS ARE DEFINED WITH A MAXIMUM LOAD C_L OF 10pF; OTHERWISE, THE LOAD IS 60pF MAXIMUM.

03083-0-002

Figure 2. Load Circuit for Digital Interface Timing, SDOU, SYNC, SCLK Outputs, $C_L = 10\text{ pF}$

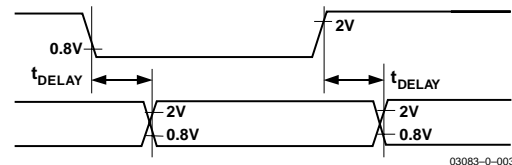

03083-0-003

Figure 3. Voltage Reference Levels for Timing

ESD CAUTION



ESD (electrostatic discharge) sensitive device. Charged devices and circuit boards can discharge without detection. Although this product features patented or proprietary protection circuitry, damage may occur on devices subjected to high energy ESD. Therefore, proper ESD precautions should be taken to avoid performance degradation or loss of functionality.

PIN CONFIGURATION AND FUNCTION DESCRIPTIONS

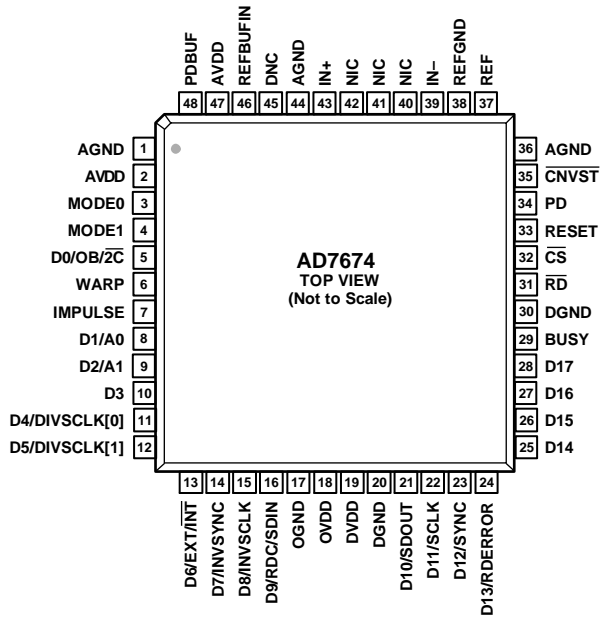

NOTES
 1. NIC = NO INTERNAL CONNECTION.
 2. DNC = DO NOT CONNECT.

Figure 4. 48-Lead LQFP Pin Configuration

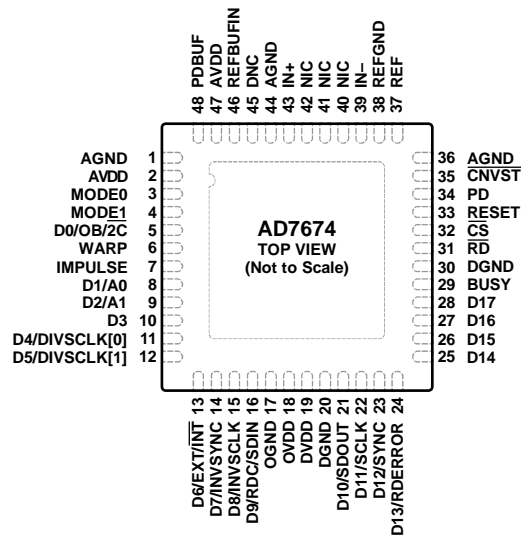

NOTES
 1. NIC = NO INTERNAL CONNECTION.
 2. DNC = DO NOT CONNECT.
 3. THE EXPOSED PAD IS INTERNALLY CONNECTED TO AGND. THIS CONNECTION IS NOT REQUIRED TO MEET THE ELECTRICAL PERFORMANCES. HOWEVER, FOR INCREASED RELIABILITY OF THE SOLDER JOINTS, IT IS RECOMMENDED THAT THE PAD BE SOLDERED TO THE ANALOG GROUND OF THE SYSTEM.

Figure 5. 48-Lead LFCSP Pin Configuration

Table 6. Pin Function Descriptions

Pin No.	Mnemonic	Type ¹	Description																				
1, 44	AGND	P	Analog Power Ground Pin.																				
2, 47	AVDD	P	Input Analog Power Pins. Nominally 5 V.																				
3	MODE0	DI	Data Output Interface Mode Selection.																				
4	MODE1	DI	Data Output Interface Mode Selection:																				
			<table border="1"> <thead> <tr> <th>Interface Mode No.</th> <th>MODE1</th> <th>MODE0</th> <th>Description</th> </tr> </thead> <tbody> <tr> <td>0</td> <td>0</td> <td>0</td> <td>18-bit interface</td> </tr> <tr> <td>1</td> <td>0</td> <td>1</td> <td>16-bit interface</td> </tr> <tr> <td>2</td> <td>1</td> <td>0</td> <td>Byte interface</td> </tr> <tr> <td>3</td> <td>1</td> <td>1</td> <td>Serial interface</td> </tr> </tbody> </table>	Interface Mode No.	MODE1	MODE0	Description	0	0	0	18-bit interface	1	0	1	16-bit interface	2	1	0	Byte interface	3	1	1	Serial interface
Interface Mode No.	MODE1	MODE0	Description																				
0	0	0	18-bit interface																				
1	0	1	16-bit interface																				
2	1	0	Byte interface																				
3	1	1	Serial interface																				
5	D0/OB/ $\overline{2C}$	DI/O	In Mode 0, 18-bit interface mode, this pin is Bit 0 of the parallel port data output bus and the data coding is straight binary. In all other modes, this pin allows a choice of straight binary/binary twos complement. When OB/ $\overline{2C}$ is high, the digital output is straight binary; when low, the MSB is inverted, resulting in a twos complement output from its internal shift register.																				
6	WARP	DI	Conversion Mode Selection. When this input is high and the IMPULSE pin is low, WARP selects the fastest mode, the maximum throughput is achievable, and a minimum conversion rate must be applied to guarantee full specified accuracy. When low, full accuracy is maintained independent of the minimum conversion rate.																				
7	IMPULSE	DI	Conversion Mode Selection. When this input is high and the WARP pin is low, IMPULSE selects a reduced power mode. In this mode, the power dissipation is approximately proportional to the sampling rate. When the WARP pin and the IMPULSE pin are low, the normal mode is selected.																				
8	D1/A0	DI/O	In Mode 0, 18-bit interface mode, this pin is Bit 1 of the parallel port data output bus. In all other modes, this input pin controls the form in which data is output, as shown in Table 7.																				
9	D2/A1	DI/O	In Mode 0, 18-bit interface mode, or Mode 1, 16-bit interface mode, this pin is Bit 2 of the parallel port data output bus. In all other modes, this input pin controls the form in which data is output, as shown in Table 7.																				
10	D3	DO	In all modes except Mode 3, this output is used as Bit 3 of the parallel port data output bus. This pin is always an output, regardless of the interface mode.																				

Pin No.	Mnemonic	Type ¹	Description
11, 12	D4/DIVSCLK[0], D5/DIVSCLK[1]	DI/O	In all modes except Mode 3, these pins are Bit 4 and Bit 5 of the parallel port data output bus. In Mode 3, serial interface mode, when EXT/INT is low and RDC/SDIN is low (serial master read after convert), these inputs, part of the serial port, are used to slow down, if desired, the internal serial clock that clocks the data output. In other serial modes, these pins are not used.
13	D6/EXT/INT	DI/O	In all modes except Mode 3, this output is used as Bit 6 of the parallel port data output bus. In Mode 3, serial interface mode, this input, part of the serial port, is used as a digital select input for choosing the internal data clock or an external data clock. With EXT/INT tied low, the internal clock is selected on the SCLK output. With EXT/INT set to a logic high, the output data is synchronized to an external clock signal connected to the SCLK input.
14	D7/INVSCLK	DI/O	In all modes except Mode 3, this output is used as Bit 7 of the parallel port data output bus. In Mode 3, serial interface mode, this input, part of the serial port, is used to select the active state of the SYNC signal. When low, SYNC is active high. When high, SYNC is active low.
15	D8/INVSCLK	DI/O	In all modes except Mode 3, this output is used as Bit 8 of the parallel port data output bus. In Mode 3, serial interface mode, this input, part of the serial port, is used to invert the SCLK signal. It is active in both master and slave mode.
16	D9/RDC/SDIN	DI/O	In all modes except Mode 3, this output is used as Bit 9 of the parallel port data output bus. In Mode 3, serial interface mode, this input, part of the serial port, is used as either an external data input or a read mode selection input depending on the state of EXT/INT. When EXT/INT is high, RDC/SDIN can be used as a data input to daisy-chain the conversion results from two or more ADCs onto a single SDOUT line. The digital data level on SDIN is output on SDOUT with a delay of 18 SCLK periods after the initiation of the read sequence. When EXT/INT is low, RDC/SDIN is used to select the read mode. When RDC/SDIN is high, the data is output on SDOUT during conversion. When RDC/SDIN is low, the data can be output on SDOUT only when the conversion is complete.
17	OGND	P	Input/Output Interface Digital Power Ground.
18	OVDD	P	Output Interface Digital Power. Nominally at the same supply as the host interface (5 V or 3 V). Should not exceed DVDD by more than 0.3 V.
19	DVDD	P	Digital Power. Nominally at 5 V.
20	DGND	P	Digital Power Ground.
21	D10/SDOUT	DO	In all modes except Mode 3, this output is used as Bit 10 of the parallel port data output bus. In Mode 3, serial interface mode, this output, part of the serial port, is used as a serial data output synchronized to SCLK. Conversion results are stored in an on-chip register. The AD7674 provides the conversion result, MSB first, from its internal shift register. The data format is determined by the logic level of OB/2C. In serial mode when EXT/INT is low, SDOUT is valid on both edges of SCLK. In serial mode when EXT/INT is high and INVSCLK is low, SDOUT is updated on the SCLK rising edge and is valid on the next falling edge; if INVSCLK is high, SDOUT is updated on the SCLK falling edge and is valid on the next rising edge.
22	D11/SCLK	DI/O	In all modes except Mode 3, this output is used as Bit 11 of the parallel port data output bus. In Mode 3, serial interface mode, this pin, part of the serial port, is used as a serial data clock input or output, dependent upon the logic state of the EXT/INT pin. The active edge where the data SDOUT is updated depends upon the logic state of the INVSCLK pin.
23	D12/SYNC	DO	In all modes except Mode 3, this output is used as Bit 12 of the parallel port data output bus. In Mode 3, serial interface mode, this output, part of the serial port, is used as a digital output frame synchronization for use with the internal data clock (EXT/INT = logic low). When a read sequence is initiated and INVSCLK is low, SYNC is driven high and remains high while the SDOUT output is valid. When a read sequence is initiated and INVSCLK is high, SYNC is driven low and remains low while SDOUT output is valid.
24	D13/RDERROR	DO	In all modes except Mode 3, this output is used as Bit 13 of the parallel port data output bus. In Mode 3, serial interface mode, and when EXT/INT is high, this output, part of the serial port, is used as an incomplete read error flag. In slave mode, when a data read is started and not complete when the following conversion is complete, the current data is lost and RDERROR is pulsed high.
25 to 28	D14 to D17	DO	Bit 14 to Bit 17 of the Parallel Port Data Output Bus. These pins are always outputs regardless of the interface mode.
29	BUSY	DO	Busy Output. Transitions high when a conversion is started. Remains high until the conversion is complete and the data is latched into the on-chip shift register. The falling edge of BUSY can be used as a data ready clock signal.
30	DGND	P	Must Be Tied to Digital Ground.
31	RD	DI	Read Data. When CS and RD are both low, the interface parallel or serial output bus is enabled.

Pin No.	Mnemonic	Type ¹	Description
32	$\overline{\text{CS}}$	DI	Chip Select. When $\overline{\text{CS}}$ and $\overline{\text{RD}}$ are both low, the interface parallel or serial output bus is enabled. $\overline{\text{CS}}$ is also used to gate the external clock.
33	RESET	DI	Reset Input. When set to a logic high, reset the AD7674. Current conversion, if any, is aborted. If not used, this pin can be tied to DGND.
34	PD	DI	Power-Down Input. When set to a logic high, power consumption is reduced and conversions are inhibited after the current one is completed.
35	$\overline{\text{CNVST}}$	DI	Start Conversion. A falling edge on $\overline{\text{CNVST}}$ puts the internal sample/hold into the hold state and initiates a conversion. In impulse mode (IMPULSE high, WARP low), if $\overline{\text{CNVST}}$ is held low when the acquisition phase (t_s) is complete, the internal sample/hold is put into hold and a conversion is immediately started.
36	AGND	P	Must Be Tied to Analog Ground.
37	REF	AI	Reference Input Voltage and Internal Reference Buffer Output. Apply an external reference on REF if the internal reference buffer is not used. Should be decoupled effectively with or without the internal buffer.
38	REFGND	AI	Reference Input Analog Ground.
39	IN-	AI	Differential Negative Analog Input.
40 to 42	NIC		No Internal Connection.
43	IN+	AI	Differential Positive Analog Input.
45	DNC		Do Not Connect. Do not connect to this pin.
46	REFBUFIN	AI	Reference Buffer Input Voltage. The internal reference buffer has a fixed gain. It outputs 4.096 V typically when 2.5 V is applied on this pin.
48	PDBUF	DI	Allows Choice of Buffering Reference. When low, buffer is selected. When high, buffer is switched off.
0	EPAD		Exposed Pad. The exposed pad is internally connected to AGND. This connection is not required to meet the electrical performances. However, for increased reliability of the solder joints, it is recommended that the pad be soldered to the analog ground of the system.

¹AI = Analog Input; DI = Digital Input; DI/O = Bidirectional Digital; DO = Digital Output; P = Power.

Table 7. Data Bus Interface Definitions¹

Mode	MODE1	MODE0	D0/OB/ $\overline{2C}$	D1/A0	D2/A1	D[3]	D[4:9]	D[10:11]	D[12:15]	D[16:17]	Description
0	0	0	R[0]	R[1]	R[2]	R[3]	R[4:9]	R[10:11]	R[12:15]	R[16:17]	18-bit parallel
1	0	1	OB/ $\overline{2C}$	A0:0	R[2]	R[3]	R[4:9]	R[10:11]	R[12:15]	R[16:17]	16-bit high word
1	0	1	OB/ $\overline{2C}$	A0:1	R[0]	R[1]	All zeros			R[16:17]	16-bit low word
2	1	0	OB/ $\overline{2C}$	A0:0	A1:0	All high-Z		R[10:11]	R[12:15]	R[16:17]	8-bit high byte
2	1	0	OB/ $\overline{2C}$	A0:0	A1:1	All high-Z		R[2:3]	R[4:7]	R[8:9]	8-bit mid byte
2	1	0	OB/ $\overline{2C}$	A0:1	A1:0	All high-Z		R[0:1]	All zeros		8-bit low byte
2	1	0	OB/ $\overline{2C}$	A0:1	A1:1	All high-Z		All zeros		R[0:1]	8-bit low byte
3	1	1	OB/ $\overline{2C}$	All high-Z			Serial interface				Serial interface

¹ R[0:17] is the 18-bit ADC value stored in its output register.

TERMINOLOGY

Integral Nonlinearity Error (INL)

Linearity error refers to the deviation of each individual code from a line drawn from negative full scale through positive full scale. The point used as negative full scale occurs ½ LSB before the first code transition. Positive full scale is defined as a level 1½ LSB beyond the last code transition. The deviation is measured from the middle of each code to the true straight line.

Differential Nonlinearity Error (DNL)

In an ideal ADC, code transitions are 1 LSB apart. Differential nonlinearity is the maximum deviation from this ideal value. It is often specified in terms of resolution for which no missing codes are guaranteed.

Gain Error

The first transition (from 000...00 to 000...01) should occur for an analog voltage ½ LSB above the nominal negative full scale (–4.095991 V for the ±4.096 V range). The last transition (from 111...10 to 111...11) should occur for an analog voltage 1½ LSB below the nominal full scale (4.095977 V for the ±4.096 V range). The gain error is the deviation of the difference between the actual level of the last transition and the actual level of the first transition from the difference between the ideal levels.

Zero Error

The zero error is the difference between the ideal midscale input voltage (0 V) from the actual voltage producing the midscale output code.

Spurious-Free Dynamic Range (SFDR)

SFDR is the difference, in decibels (dB), between the rms amplitude of the input signal and the peak spurious signal.

Effective Number of Bits (ENOB)

ENOB is a measurement of the resolution with a sine wave input, and is expressed in bits. It is related to SINAD by the following formula:

$$ENOB = (SINAD_{dB} - 1.76)/6.02$$

Total Harmonic Distortion (THD)

THD is the ratio of the rms sum of the first five harmonic components to the rms value of a full-scale input signal, and is expressed in decibels.

Dynamic Range

Dynamic range is the ratio of the rms value of the full scale to the rms noise measured with the inputs shorted together. The value for dynamic range is expressed in decibels.

Signal-to-Noise Ratio (SNR)

SNR is the ratio of the rms value of the actual input signal to the rms sum of all other spectral components below the Nyquist frequency, excluding harmonics and dc. The value for SNR is expressed in decibels.

Signal-to-Noise-and-Distortion Ratio (SINAD)

SINAD is the ratio of the rms value of the actual input signal to the rms sum of all other spectral components below the Nyquist frequency, including harmonics but excluding dc. The value for SINAD is expressed in decibels.

Aperture Delay

Aperture delay is a measure of the acquisition performance and is measured from the falling edge of the CNVST input to when the input signal is held for a conversion.

Transient Response

Transient response is the time required for the AD7674 to achieve its rated accuracy after a full-scale step function is applied to its input.

TYPICAL PERFORMANCE CHARACTERISTICS

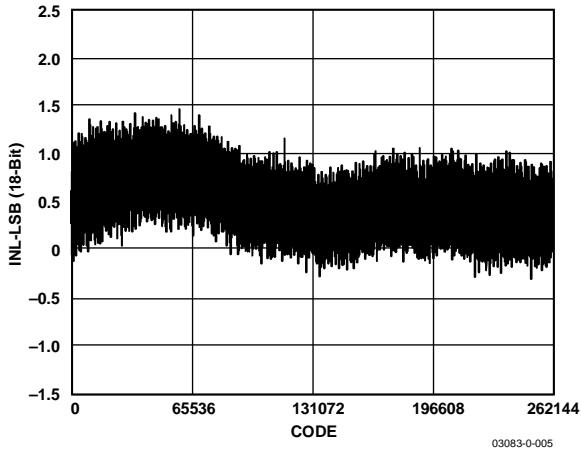

Figure 6. Integral Nonlinearity vs. Code

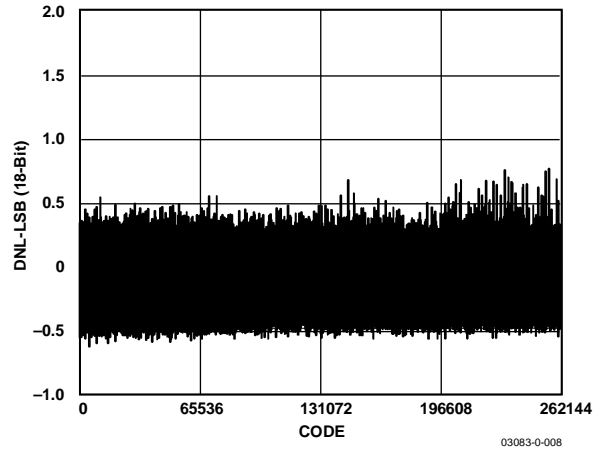

Figure 9. Differential Nonlinearity vs. Code

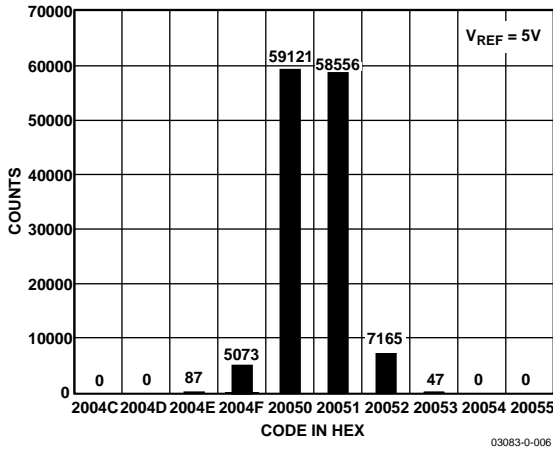

Figure 7. Histogram of 131,072 Conversions of a DC Input at the Code Transition

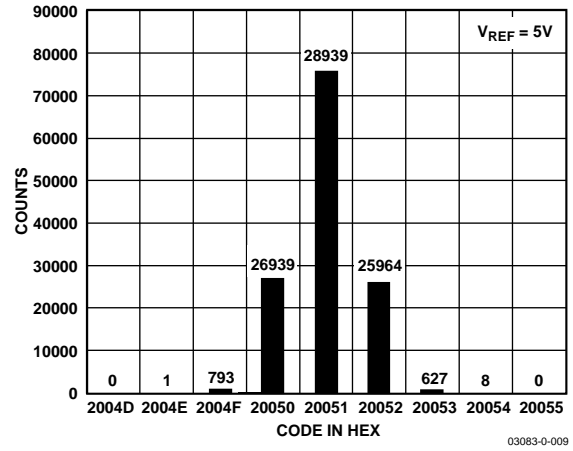

Figure 10. Histogram of 131,072 Conversions of a DC Input at the Code Center

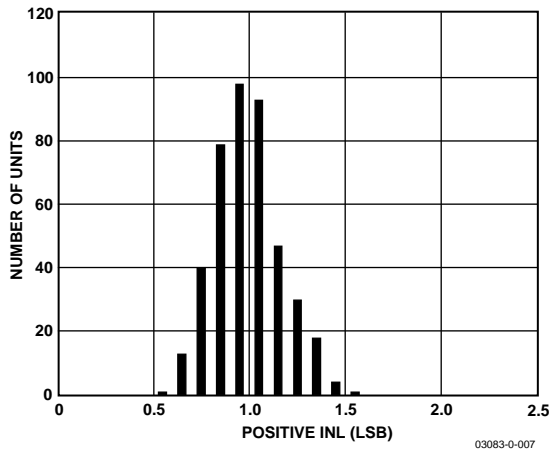

Figure 8. Typical Positive INL Distribution (424 Units)

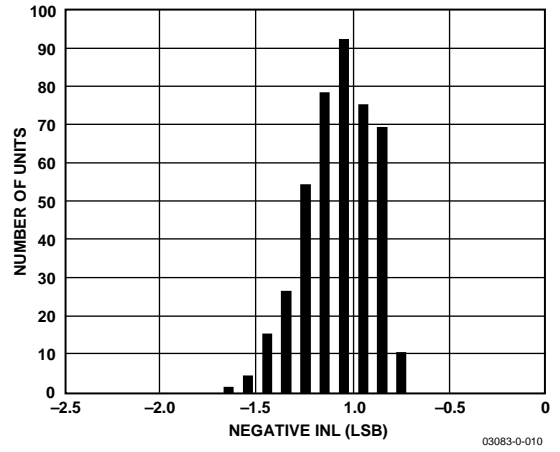

Figure 11. Typical Negative INL Distribution (424 Units)

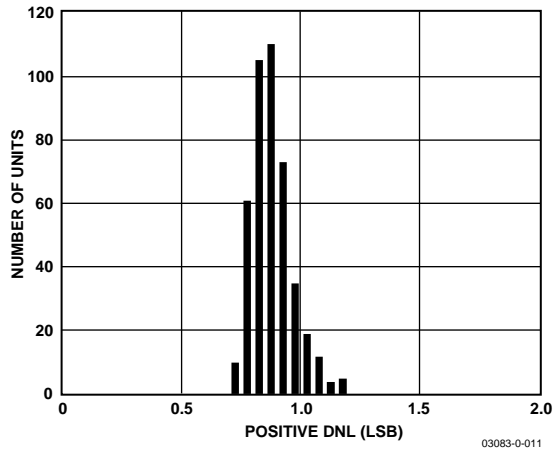

Figure 12. Typical Positive DNL Distribution (424 Units)

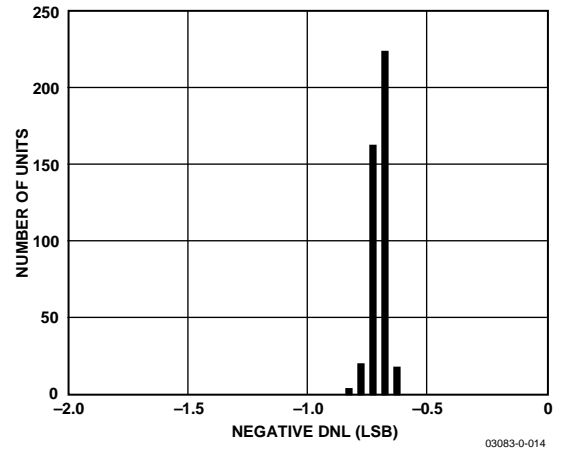

Figure 15. Typical Negative DNL Distribution (424 Units)

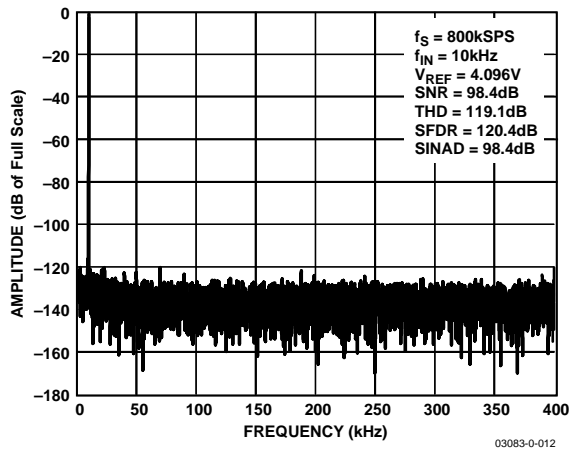

Figure 13. FFT (10 kHz Tone)

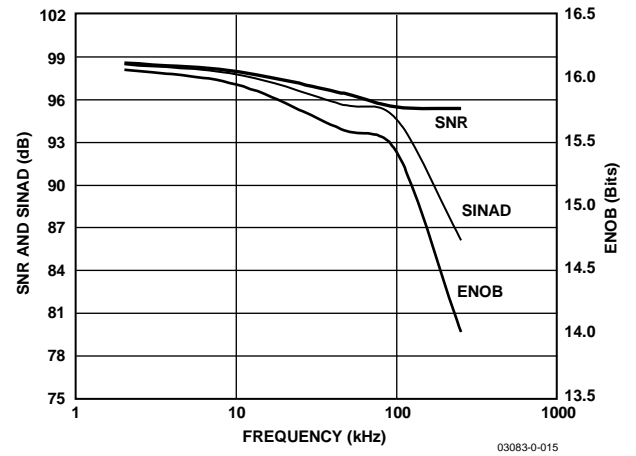

Figure 16. SNR, SINAD, and ENOB vs. Frequency

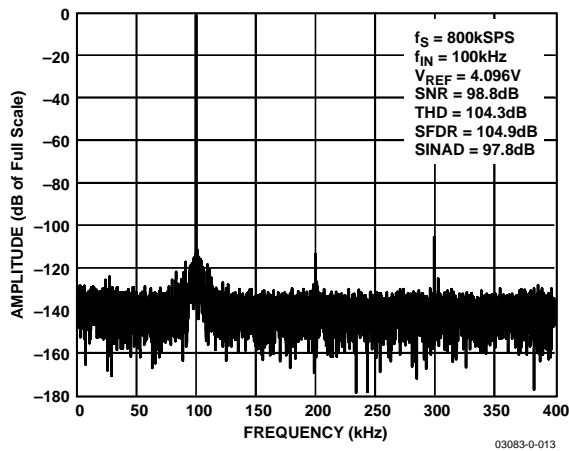

Figure 14. FFT (100 kHz Tone)

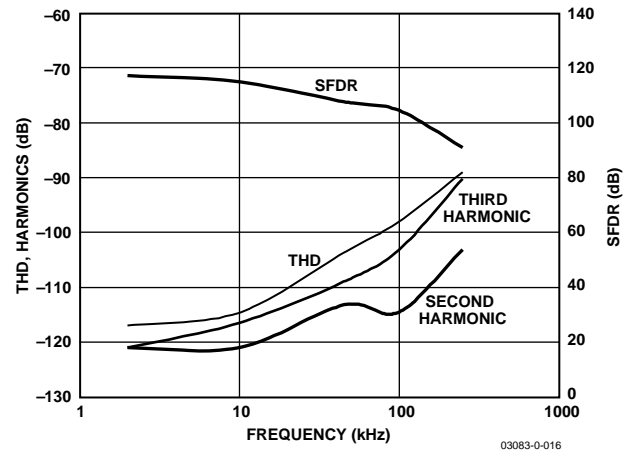

Figure 17. THD, SFDR, and Harmonics vs. Frequency

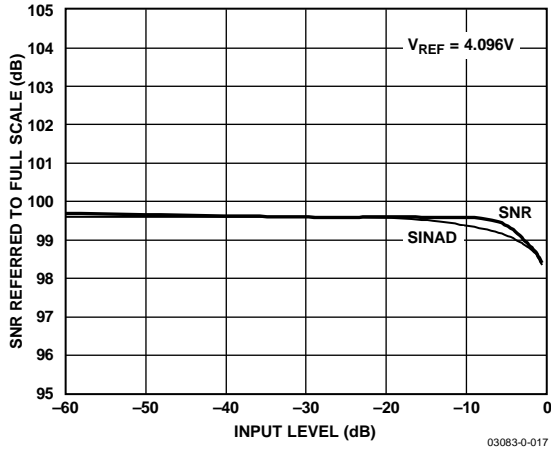

Figure 18. SNR and SINAD vs. Input Level

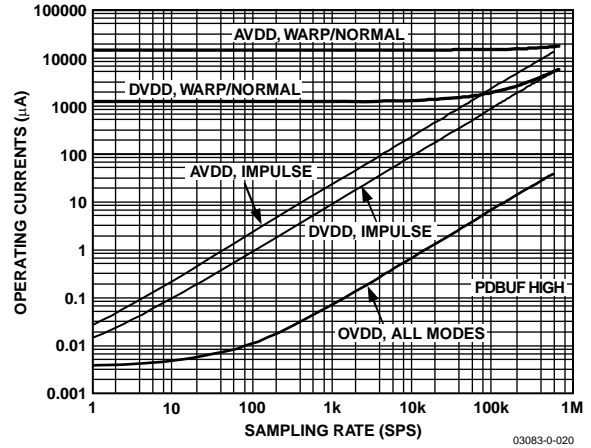

Figure 21. Operating Current vs. Sampling Rate

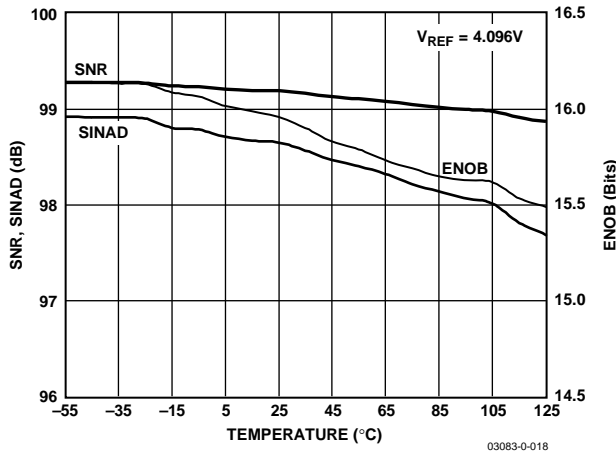

Figure 19. SNR, SINAD, and ENOB vs. Temperature

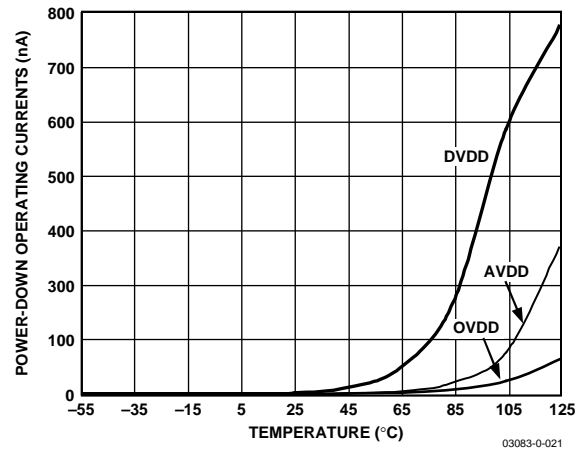

Figure 22. Power-Down Operating Currents vs. Temperature

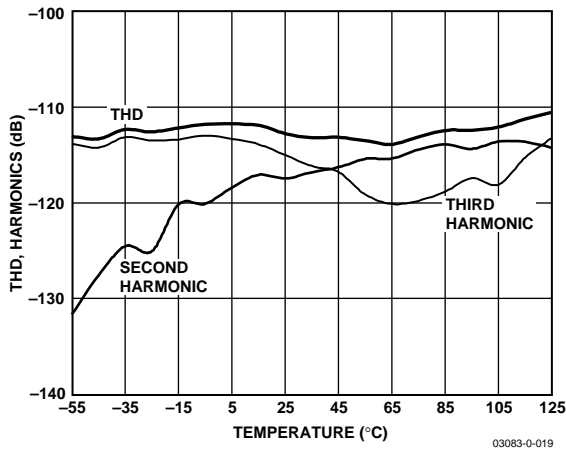

Figure 20. THD and Harmonics vs. Temperature

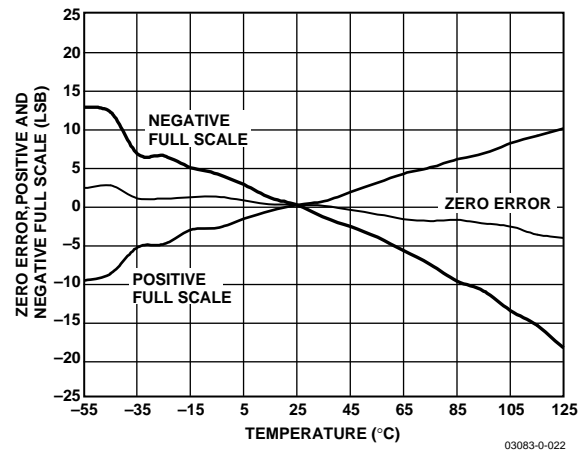

Figure 23. Zero Error, Positive Full Scale, and Negative Full Scale vs. Temperature

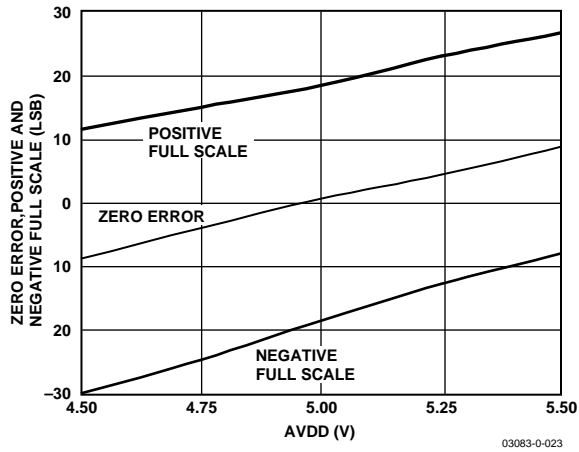

Figure 24. Zero Error, Positive Full Scale, and Negative Full Scale vs. Supply

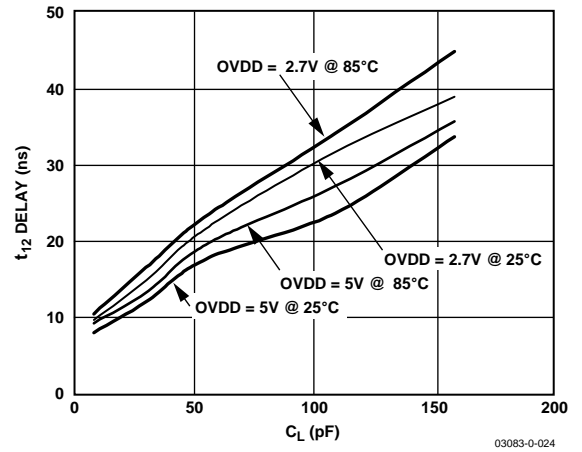

Figure 25. Typical Delay vs. Load Capacitance (C_i)

CIRCUIT INFORMATION

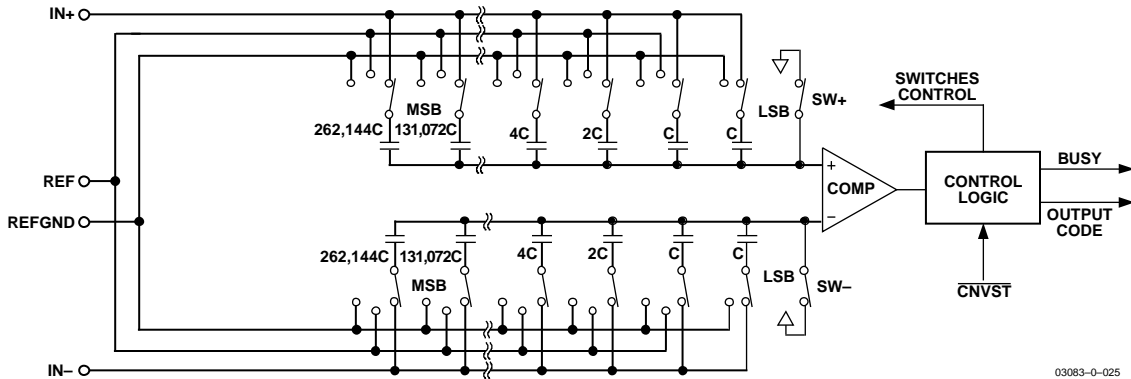

Figure 26. ADC Simplified Schematic

The [AD7674](#) is a very fast, low power, single-supply, precise 18-bit analog-to-digital converter (ADC) using successive approximation architecture.

The linearity and dynamic range of the [AD7674](#) are similar to or better than many Σ - Δ ADCs. With the advantages of its successive architecture, which ease multiplexing and reduce power with throughput, it can be advantageous in applications that normally use Σ - Δ ADCs.

The [AD7674](#) features different modes to optimize performance according to the applications. In warp mode, the [AD7674](#) is capable of converting 800,000 samples per second (800 kSPS).

The [AD7674](#) provides the user with an on-chip track/hold, successive approximation ADC that does not exhibit any pipeline or latency, making it ideal for multiple multiplexed channel applications.

The [AD7674](#) can be operated from a single 5 V supply and can be interfaced to either 5 V or 3 V digital logic. It is housed in a 48-lead LQFP, or a tiny 48-lead LFCSP that offers space savings and allows for flexible configurations as either a serial or parallel interface. The [AD7674](#) is a pin-to-pin compatible upgrade of the [AD7676](#), [AD7678](#), and [AD7679](#).

CONVERTER OPERATION

The [AD7674](#) is a successive approximation ADC based on a charge redistribution DAC. Figure 26 shows the simplified schematic of the ADC. The capacitive DAC consists of two identical arrays of 18 binary weighted capacitors that are connected to the two comparator inputs.

During the acquisition phase, terminals of the array tied to the input of the comparator are connected to AGND via SW+ and SW-. All independent switches are connected to the analog inputs. Thus, the capacitor arrays are used as sampling capacitors and acquire the analog signal on the IN+ and IN- inputs. When the acquisition phase is complete and the CNVST input goes low, a conversion phase is initiated. When the conversion phase begins, SW+ and SW- are opened first. The two capacitor arrays are then disconnected from the inputs and connected to the REFV input. Therefore, the differential voltage between

the IN+ and IN- inputs captured at the end of the acquisition phase is applied to the comparator inputs, causing the comparator to become unbalanced. By switching each element of the capacitor array between REFV and REFV/2, the comparator input varies by binary weighted voltage steps ($V_{REF}/2$, $V_{REF}/4$, ... $V_{REF}/262144$). The control logic toggles these switches, starting with the MSB first, to bring the comparator back into a balanced condition. After completing this process, the control logic generates the ADC output code and brings the BUSY output low.

Modes of Operation

The [AD7674](#) features three modes of operation: warp, normal, and impulse. Each mode is more suited for specific applications.

Warp mode allows conversion rates up to 800 kSPS. However, in this mode and this mode only, the full specified accuracy is guaranteed only when the time between conversions does not exceed 1 ms. If the time between two consecutive conversions is longer than 1 ms (for example, after power-up), the first conversion result should be ignored. This mode makes the [AD7674](#) ideal for applications where a fast sample rate is required.

Normal mode is the fastest mode (666 kSPS) without any limitation on the time between conversions. This mode makes the [AD7674](#) ideal for asynchronous applications such as data acquisition systems, where both high accuracy and fast sample rate are required.

Impulse mode, the lowest power dissipation mode, allows power saving between conversions. The maximum throughput in this mode is 570 kSPS. When operating at 1 kSPS, for example, it typically consumes only 136 μ W. This feature makes the [AD7674](#) ideal for battery-powered applications.

Transfer Functions

Except in 18-bit interface mode, the AD7674 offers straight binary and twos complement output coding when using $OB/2C$. See Figure 27 and Table 8 for the ideal transfer characteristic.

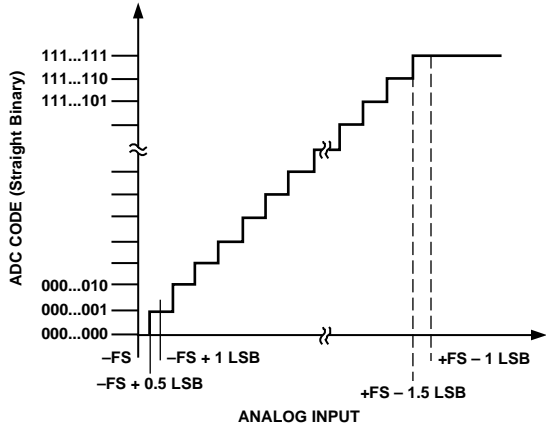

03083-0-026

Figure 27. ADC Ideal Transfer Function

Table 8. Output Codes and Ideal Input Voltages

Description	Analog Input $V_{REF} = 4.096\text{ V}$	Straight Binary (Hex)	Twos Complement (Hex)
FSR – 1 LSB	4.095962 V	3FFFF ¹	1FFFF ¹
FSR – 2 LSB	4.095924 V	3FFFE	1FFFE
Midscale + 1 LSB	31.25 μV	20001	00001
Midscale	0 V	20000	00000
Midscale – 1 LSB	–31.25 μV	1FFFF	3FFFF
–FSR + 1 LSB	–4.095962 V	00001	20001
–FSR	–4.096 V	00000 ²	20000 ²

¹ This is also the code for overrange analog input ($V_{IN+} - V_{IN-}$ above $V_{REF} - V_{REFGND}$).

² This is also the code for underrange analog input ($V_{IN+} - V_{IN-}$ below $-V_{REF} + V_{REFGND}$).

TYPICAL CONNECTION DIAGRAM

Figure 28 shows a typical connection diagram for the AD7674. Different circuitry shown on this diagram is optional and is discussed later in this data sheet.

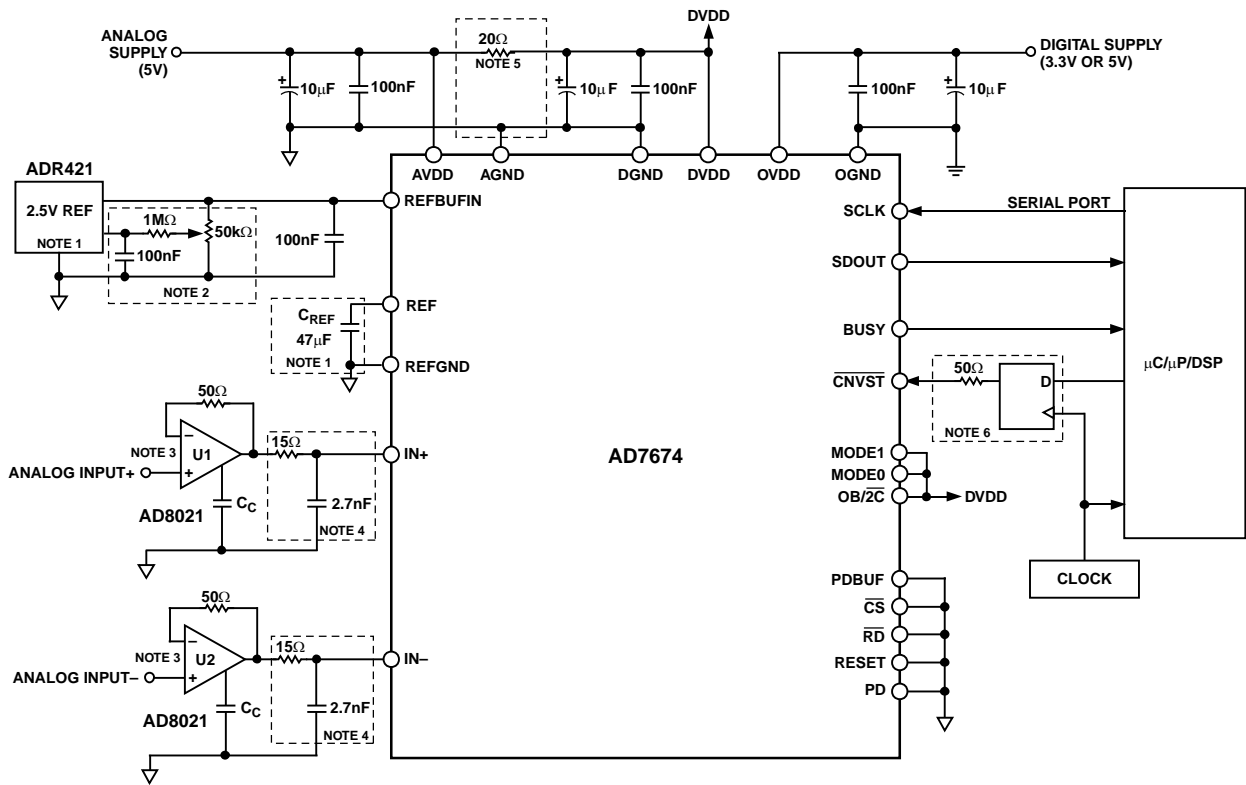

- NOTES**
1. SEE VOLTAGE REFERENCE INPUT SECTION.
 2. OPTIONAL CIRCUITRY FOR HARDWARE GAIN CALIBRATION.
 3. THE AD8021 IS RECOMMENDED. SEE DRIVER AMPLIFIER CHOICE SECTION.
 4. SEE ANALOG INPUTS SECTION.
 5. OPTION, SEE POWER SUPPLY SECTION.
 6. OPTIONAL LOW JITTER $CNVST$, SEE CONVERSION CONTROL SECTION.

03083-0-027

Figure 28. Typical Connection Diagram (Internal Reference Buffer, Serial Interface)

Analog Inputs

Figure 29 shows a simplified analog input section of the AD7674. The diodes shown in Figure 29 provide ESD protection for the inputs. Care must be taken to ensure that the analog input signal never exceeds the absolute ratings on these inputs. This causes these diodes to become forward biased and start conducting current. These diodes can handle a forward-biased current of 120 mA max. This condition can eventually occur when the U1 or U2 supplies of the input buffer are different from AVDD. In such a case, an input buffer with a short-circuit current limitation can be used to protect the device.

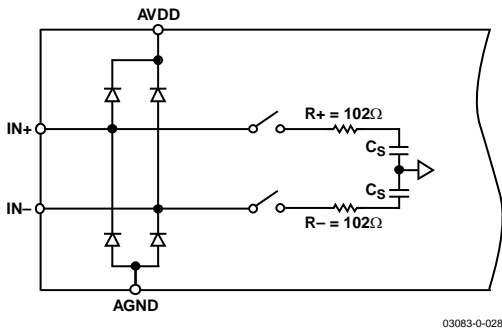

Figure 29. Simplified Analog Input

This analog input structure is a true differential structure. By using these differential inputs, signals common to both inputs are rejected as shown in Figure 30, which represents typical CMRR over frequency.

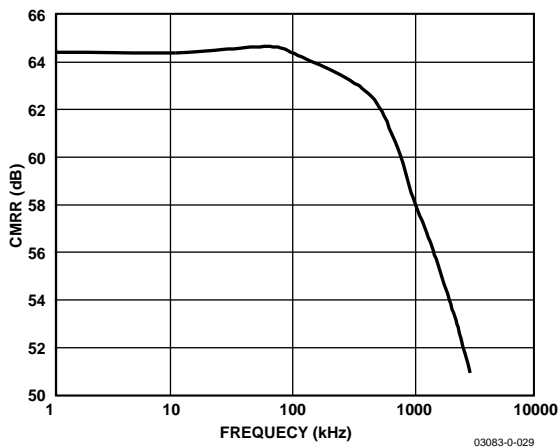

Figure 30. Analog Input CMRR vs. Frequency

During the acquisition phase for ac signals, the AD7674 behaves like a 1-pole RC filter consisting of the equivalent resistance R_+ , R_- , and C_s . The R_+ and R_- resistors are typically 102 Ω and are lumped components made up of a serial resistor and the on resistance of the switches. C_s is typically 60 pF and mainly consists of the ADC sampling capacitor. This 1-pole filter with a -3 dB cutoff frequency of 26 MHz typ reduces any undesirable aliasing effect and limits the noise coming from the inputs.

Because the input impedance of the AD7674 is very high, the device can be driven directly by a low impedance source without gain error. This allows the user to put an external 1-pole RC

filter between the amplifier output and the ADC analog inputs, as shown in Figure 28, to improve the noise filtering done by the AD7674 analog input circuit. However, the source impedance has to be kept low because it affects the ac performance, especially the total harmonic distortion (THD). The maximum source impedance depends on the amount of THD that can be tolerated. The THD degrades as a function of source impedance and the maximum input frequency, as shown in Figure 31.

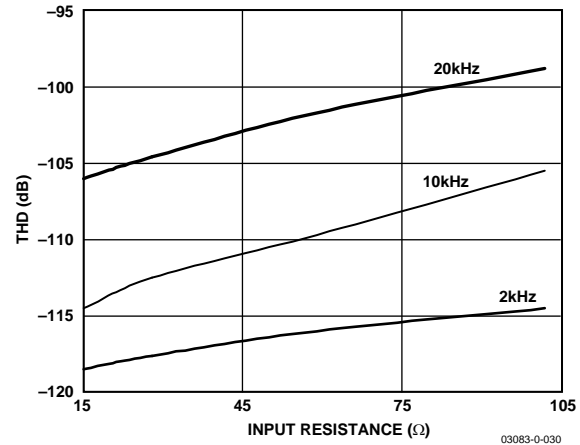

Figure 31. THD vs. Analog Input Frequency and Source Resistance

Driver Amplifier Choice

Although the AD7674 is easy to drive, the driver amplifier needs to meet the following requirements:

- The driver amplifier and the AD7674 analog input circuit have to be able to settle for a full-scale step of the capacitor array at an 18-bit level (0.0004%). In the amplifier data sheet, settling at 0.1% or 0.01% is more commonly specified. This can differ significantly from the settling time at an 18-bit level and, therefore, should be verified prior to driver selection. The tiny op amp AD8021, which combines ultralow noise and high gain-bandwidth, meets this settling time requirement.
- The noise generated by the driver amplifier needs to be kept as low as possible to preserve the SNR and transition noise performance of the AD7674. The noise coming from the driver is filtered by the AD7674 analog input circuit 1-pole low-pass filter made by R_+ , R_- , and C_s . The SNR degradation due to the amplifier is

$$SNR_{LOSS} = 20 \log \left(\frac{25}{\sqrt{625 + \pi f_{-3dB} (Ne_N)^2}} \right)$$

where:

f_{-3dB} is the -3 dB input bandwidth in MHz of the AD7674 (26 MHz) or the cutoff frequency of the input filter, if used.
 N is the noise factor of the amplifiers (1 if in buffer configuration).

e_N is the equivalent input noise voltage of each op amp in nV/\sqrt{Hz} .

For instance, for a driver with an equivalent input noise of $2 \text{ nV}/\sqrt{\text{Hz}}$ (for example, the AD8021) configured as a buffer, thus with a noise gain of +1, the SNR degrades by only 0.34 dB with the filter in Figure 28, and by 1.8 dB without it.

- The driver needs to have a THD performance suitable to that of the AD7674.

The AD8021 meets these requirements and is usually appropriate for almost all applications. The AD8021 needs a 10 pF external compensation capacitor, which should have good linearity as an NPO ceramic or mica type.

The AD8022 can be used if a dual version is needed and gain of 1 is present. The AD829 is an alternative in applications where high frequency (above 100 kHz) performance is not required. In gain of 1 applications, it requires an 82 pF compensation capacitor. The AD8610 is another option when low bias current is needed in low frequency applications.

Single-to-Differential Driver

For applications using unipolar analog signals, a single-ended-to-differential driver allows for a differential input into the device. The schematic is shown in Figure 32. When provided an input signal of 0 to V_{REF} , this configuration produces a differential $\pm V_{\text{REF}}$ with midscale at $V_{\text{REF}}/2$.

If the application can tolerate more noise, the AD8138 differential driver can be used.

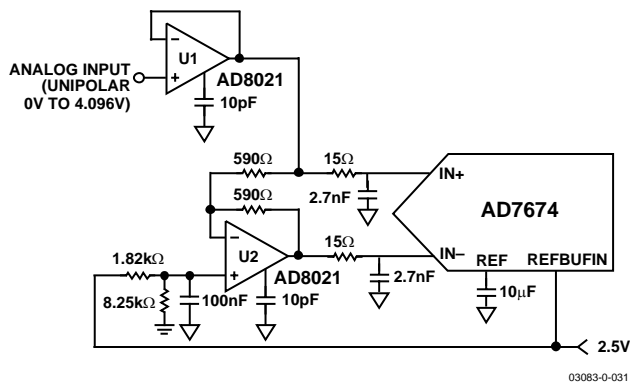

Figure 32. Single-Ended-to-Differential Driver Circuit
(Internal Reference Buffer Used)

Voltage Reference

The AD7674 allows the use of an external voltage reference either with or without the internal reference buffer.

Using the internal reference buffer is recommended when sharing a common reference voltage between multiple ADCs is desired.

However, the advantages of using the external reference voltage directly are:

- The SNR and dynamic range improvement (about 1.7 dB) resulting from the use of a reference voltage very close to the supply (5 V) instead of a typical 4.096 V reference when the internal buffer is used.
- The power saving when the internal reference buffer is powered down (PDBUF High)

To use the internal reference buffer, PDBUF should be LOW. A 2.5 V reference voltage applied on the REFBUFIN input results in a 4.096 V reference on the REF pin.

In both cases, the voltage reference input REF has a dynamic input impedance and therefore requires an efficient decoupling between REF and REFGND inputs. The decoupling consists of a low ESR 47 μF tantalum capacitor connected to the REF and REFGND inputs with minimum parasitic inductance.

Care should also be taken with the reference temperature coefficient of the voltage reference, which directly affects the full-scale accuracy if this parameter matters. For instance, a $\pm 4 \text{ ppm}/^\circ\text{C}$ temperature coefficient of the reference changes the full scale by $\pm 1 \text{ LSB}/^\circ\text{C}$.

Power Supply

The AD7674 uses three sets of power supply pins: an analog 5 V supply (AVDD), a digital 5 V core supply (DVDD), and a digital output interface supply (OVDD). The OVDD supply defines the output logic level and allows direct interface with any logic working between 2.7 V and $\text{DVDD} + 0.3 \text{ V}$. To reduce the number of supplies needed, the digital core (DVDD) can be supplied through a simple RC filter from the analog supply, as shown in Figure 28. The AD7674 is independent of power supply sequencing once OVDD does not exceed DVDD by more than 0.3 V, and is therefore free from supply voltage induced latch-up. Additionally, it is very insensitive to power supply variations over a wide frequency range, as shown in Figure 33.

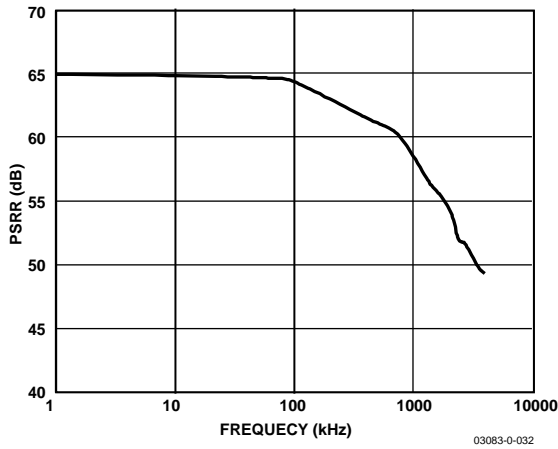

Figure 33. PSRR vs. Frequency

POWER DISSIPATION VERSUS THROUGHPUT

In Impulse mode, the AD7674 automatically reduces its power consumption at the end of each conversion phase. During the acquisition phase, the operating currents are very low, which allows for a significant power savings when the conversion rate is reduced, as shown in Figure 34. This feature makes the AD7674 ideal for very low power battery applications. It should be noted that the digital interface remains active even during the acquisition phase. To reduce the operating digital supply currents even further, the digital inputs need to be driven close to the power rails (DVDD and DGND), and OVDD should not exceed DVDD by more than 0.3 V.

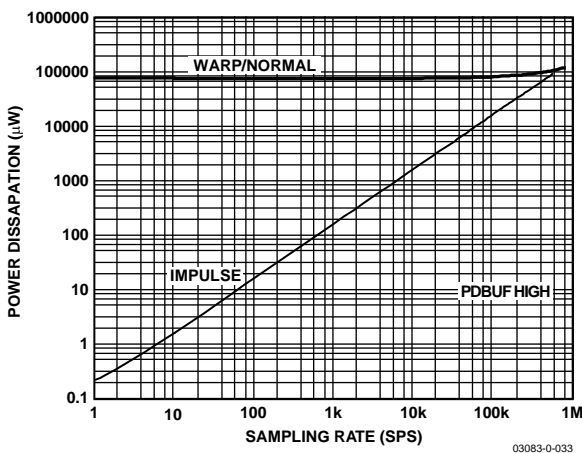

Figure 34. Power Dissipation vs. Sample Rate

CONVERSION CONTROL

Figure 35 shows the detailed timing diagrams of the conversion process. The AD7674 is controlled by the $\overline{\text{CNVST}}$ signal, which initiates conversion. Once initiated, it cannot be restarted or aborted, even by PD, until the conversion is complete. The $\overline{\text{CNVST}}$ signal operates independently of $\overline{\text{CS}}$ and $\overline{\text{RD}}$ signals.

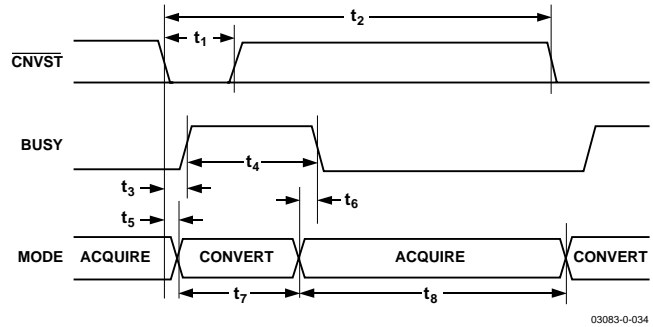

Figure 35. Basic Conversion Timing

Although $\overline{\text{CNVST}}$ is a digital signal, it should be designed with special care with fast, clean edges and levels with minimum overshoot and undershoot or ringing.

For applications where SNR is critical, the $\overline{\text{CNVST}}$ signal should have very low jitter. This may be achieved by using a dedicated oscillator for $\overline{\text{CNVST}}$ generation, or to clock it with a high frequency low jitter clock, as shown in Figure 28.

In Impulse mode, conversions can be initiated automatically. If $\overline{\text{CNVST}}$ is held low when BUSY goes low, the AD7674 controls the acquisition phase and automatically initiates a new conversion. By keeping $\overline{\text{CNVST}}$ low, the AD7674 keeps the conversion process running by itself. Note that the analog input has to be settled when BUSY goes low. Also, at power-up, $\overline{\text{CNVST}}$ should be brought low once to initiate the conversion process. In this mode, the AD7674 can sometimes run slightly faster than the guaranteed limits of 570 kSPS in Impulse mode. This feature does not exist in Warp or Normal modes.

DIGITAL INTERFACE

The AD7674 has a versatile digital interface; it can be interfaced with the host system by using either a serial or parallel interface. The serial interface is multiplexed on the parallel data bus. The AD7674 digital interface also accommodates both 3 V and 5 V logic by simply connecting the OVDD supply pin of the AD7674 to the host system interface digital supply. Finally, by using the OB/2C input pin in any mode but 18-bit interface mode, both twos complement and straight binary coding can be used.

The two signals, $\overline{\text{CS}}$ and $\overline{\text{RD}}$, control the interface. When at least one of these signals is high, the interface outputs are in high impedance. Usually, $\overline{\text{CS}}$ allows the selection of each AD7674 in multicircuit applications, and is held low in a single AD7674 design. $\overline{\text{RD}}$ is generally used to enable the conversion result on the data bus.

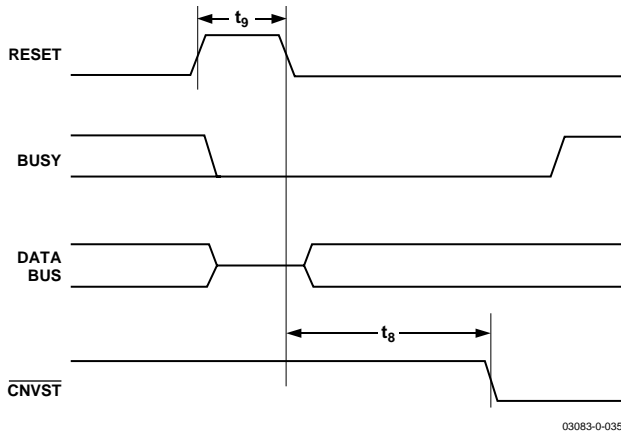

Figure 36. RESET Timing

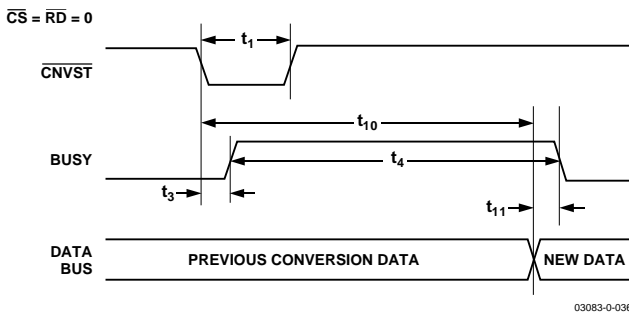

Figure 37. Master Parallel Data Timing for Reading (Continuous Read)

PARALLEL INTERFACE

The AD7674 is configured to use the parallel interface with an 18-bit, a 16-bit, or an 8-bit bus width, according to Table 7. The data can be read either after each conversion, which is during the next acquisition phase, or during the following conversion, as shown in Figure 38 and Figure 39, respectively. When the data is read during the conversion, however, it is recommended that it is read only during the first half of the conversion phase. This avoids any potential feedthrough between voltage transients on the digital interface and the most critical analog conversion circuitry. Refer to Table 7 for a detailed description of the different options available.

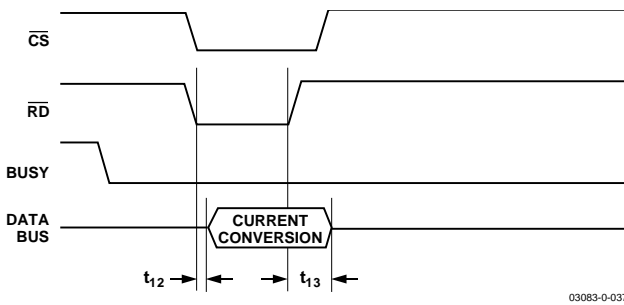

Figure 38. Slave Parallel Data Timing for Reading (Read After Convert)

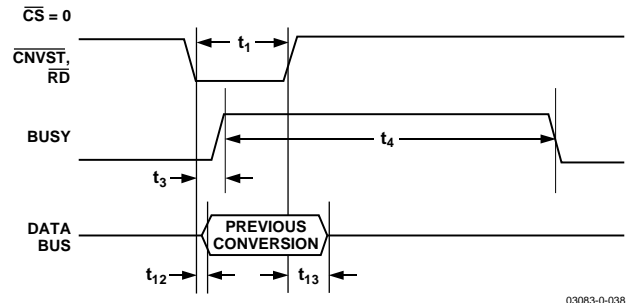

Figure 39. Slave Parallel Data Timing for Reading (Read During Convert)

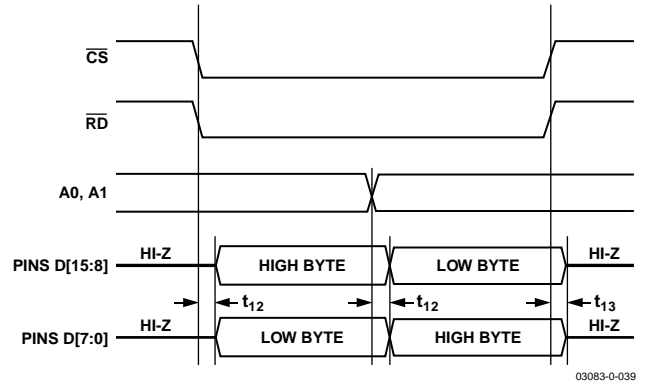

Figure 40. 8-Bit and 16-Bit Parallel Interface

SERIAL INTERFACE

The AD7674 is configured to use the serial interface when MODE0 and MODE1 are held high. The AD7674 outputs 18 bits of data, MSB first, on the SDO pin. This data is synchronized with the 18 clock pulses provided on the SCLK pin. The output data is valid on both the rising and falling edge of the data clock.

MASTER SERIAL INTERFACE

Internal Clock

The AD7674 is configured to generate and provide the serial data clock SCLK when the EXT/INT pin is held low. The AD7674 also generates a SYNC signal to indicate to the host when the serial data is valid. The serial clock SCLK and the SYNC signal can be inverted if desired. Depending on the RDC/SDIN input, the data can be read after each conversion or during the following conversion. Figure 41 and Figure 42 show the detailed timing diagrams of these two modes.

Usually, because the AD7674 is used with a fast throughput, the master read during conversion mode is the most recommended serial mode.

In read during conversion mode, the serial clock and data toggle at appropriate instants, minimizing potential feedthrough between digital activity and critical conversion decisions.

In read after conversion mode, note that unlike in other modes, the BUSY signal returns low after the 18 data bits are pulsed out and not at the end of the conversion phase, which results in a longer BUSY width. To accommodate slow digital hosts, the serial clock can be slowed down by using DIVSCLK.

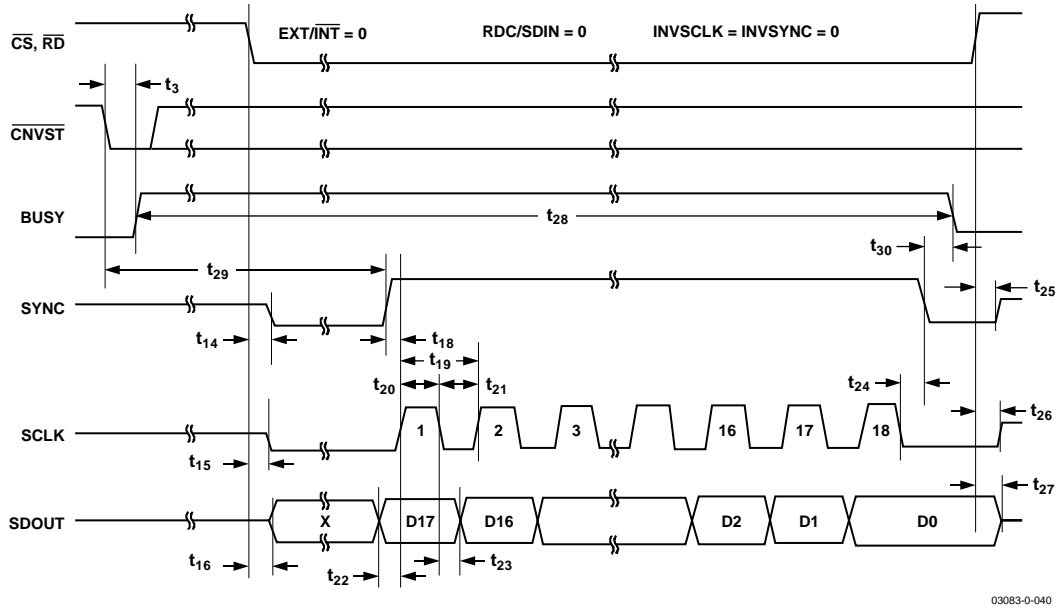

03083-0-040

Figure 41. Master Serial Data Timing for Reading (Read After Convert)

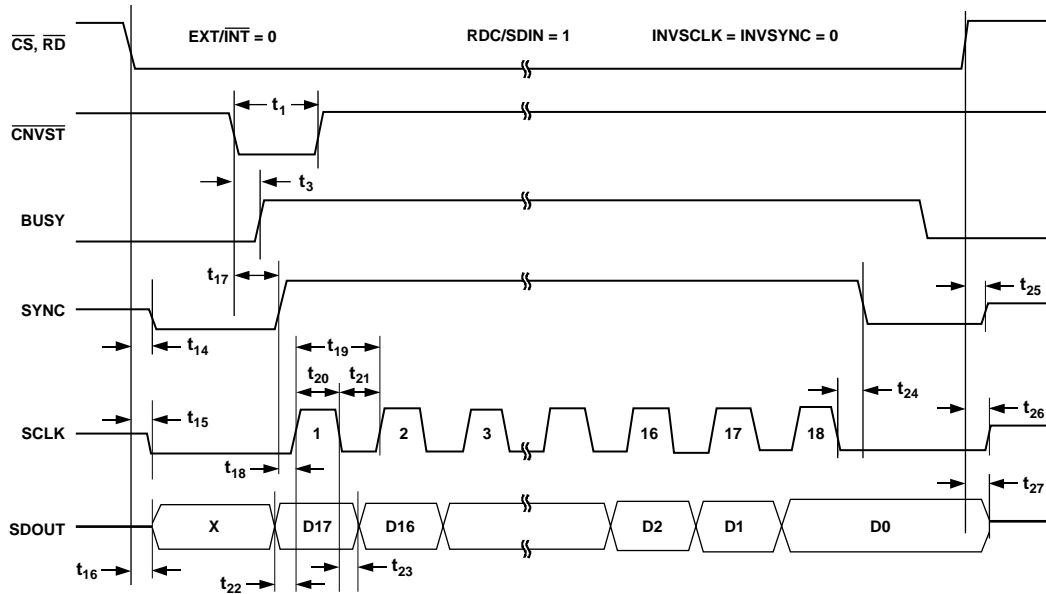

03083-0-046

Figure 42. Master Serial Data Timing for Reading (Read Previous Conversion During Convert)

SLAVE SERIAL INTERFACE

External Clock

The AD7674 is configured to accept an externally supplied serial data clock on the SCLK pin when the EXT/INT pin is held high. In this mode, several methods can be used to read the data. The external serial clock is gated by CS. When CS and RD are both low, the data can be read after each conversion or during the following conversion. The external clock can be either a continuous or a discontinuous clock. A discontinuous clock can be either normally high or normally low when inactive. Figure 43 and Figure 44 show the detailed timing diagrams of these methods.

While the AD7674 is performing a bit decision, it is important that voltage transients not occur on digital input/output pins or degradation of the conversion result can occur. This is particularly important during the second half of the conversion phase because the AD7674 provides error correction circuitry that can correct for an improper bit decision made during the first half of the conversion phase. For this reason, it is recommended that when an external clock is being provided, it is a discontinuous clock that only toggles when BUSY is low or, more importantly, that it does not transition during the latter half of BUSY high.

External Discontinuous Clock Data Read after Conversion

Though maximum throughput cannot be achieved using this mode, it is the most recommended of the serial slave modes. Figure 43 shows the detailed timing diagrams of this method. After a conversion is complete, indicated by BUSY returning low, the result of this conversion can be read while both CS and RD are low. Data is shifted out MSB first with 18 clock pulses, and is valid on the rising and falling edge of the clock.

Among the advantages of this method, the conversion performance is not degraded because there are no voltage transients on the digital interface during the conversion process. Also, data can be read at speeds up to 40 MHz, accommodating both slow digital host interface and the fastest serial reading.

Finally, in this mode only, the AD7674 provides a daisy-chain feature using the RDC/SDIN input pin to cascade multiple converters together. This feature is useful for reducing component count and wiring connections when desired (for instance, in isolated multiconverter applications).

An example of the concatenation of two devices is shown in Figure 45. Simultaneous sampling is possible by using a common CNVST signal. It should be noted that the RDC/SDIN input is latched on the edge of SCLK opposite the one used to shift out data on SDOU. Thus, the MSB of the upstream converter follows the LSB of the downstream converter on the next SCLK cycle.

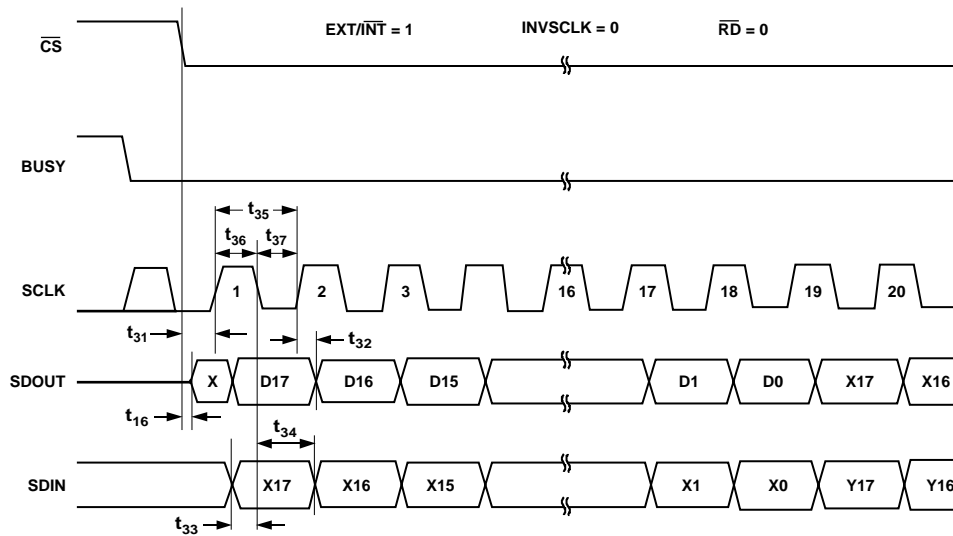

Figure 43. Slave Serial Data Timing for Reading (Read After Convert)

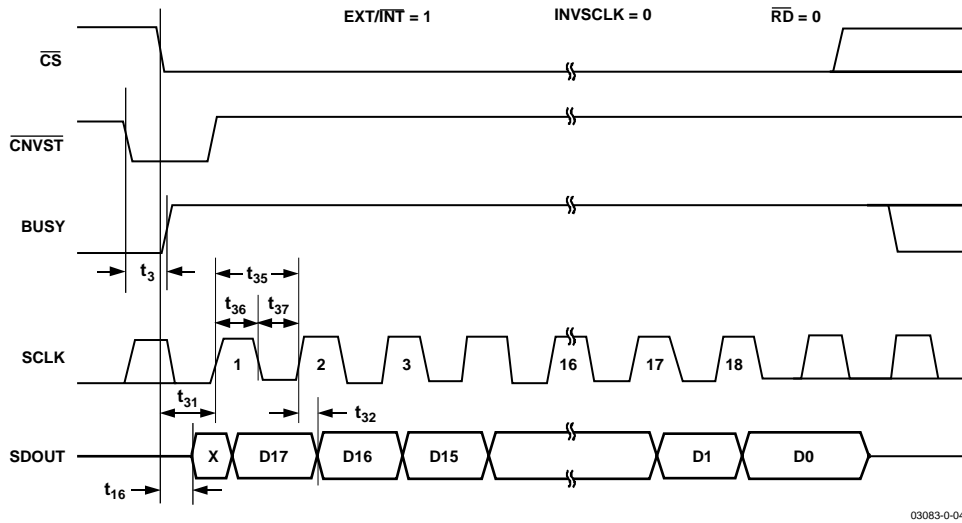

Figure 44. Slave Serial Data Timing for Reading (Read Previous Conversion During Convert)

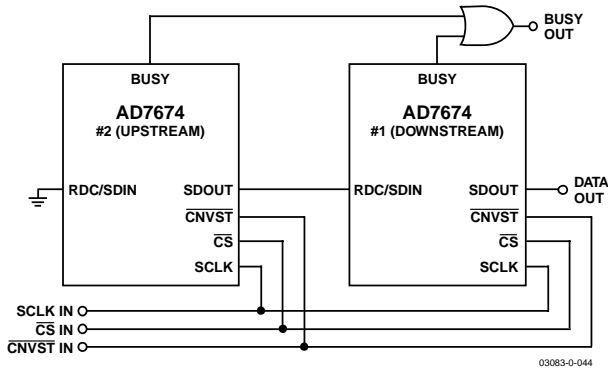

Figure 45. Two AD7674 Devices in a Daisy-Chain Configuration

External Clock Data Read during Conversion

Figure 44 shows the detailed timing diagrams of this method. During a conversion, while both CS and RD are low, the result of the previous conversion can be read. The data is shifted out MSB first with 18 clock pulses, and is valid on both the rising and falling edge of the clock. The 18 bits have to be read before the current conversion is complete. If that is not done, RDERROR is pulsed high and can be used to interrupt the host interface to prevent incomplete data reading. There is no daisy-chain feature in this mode, and the RDC/SDIN input should always be tied either high or low.

To reduce performance degradation due to digital activity, a fast discontinuous clock is recommended to ensure that all bits are read during the first half of the conversion phase. It is also possible to begin to read the data after conversion and continue to read the last bits even after a new conversion has been initiated.

MICROPROCESSOR INTERFACING

The AD7674 is ideally suited for traditional dc measurement applications supporting a microprocessor, and for ac signal processing applications interfacing to a digital signal processor. The AD7674 is designed to interface either with a parallel 8-bit or 16-bit wide interface, or with a general-purpose serial port or

input/output ports on a microcontroller. A variety of external buffers can be used with the AD7674 to prevent digital noise from coupling into the ADC. The Serial Peripheral Interface (SPI) section illustrates the use of the AD7674 with an SPI equipped DSP, the ADSP-2191M.

Serial Peripheral Interface (SPI)

The AD7674 digital interface is compatible with SPI. As an example, Figure 46 shows an interface diagram between the AD7674 and the SPI equipped ADSP-2191M. To accommodate the slower speed of the DSP, the AD7674 acts as a slave device, and data must be read after conversion. This mode also allows the daisy-chain feature. The convert command can be initiated in response to an internal timer interrupt. The 18-bit output data are read with 3-byte SPI access. The reading process can be initiated in response to the end-of-conversion signal (BUSY going low) using an interrupt line of the DSP. The serial interface (SPI) on the ADSP-2191M is configured for master mode (MSTR) = 1, Clock Polarity Bit (CPOL) = 0, Clock Phase Bit (CPHA) = 1, and SPI interrupt enable (TIMOD) = 00, by writing to the SPI Control register (SPICLTx). It should be noted that to meet all timing requirements, the SPI clock should be limited to 17 Mbps, which allows it to read an ADC result in about 1.1 μs. When a higher sampling rate is desired, use of one of the parallel interface modes is recommended.

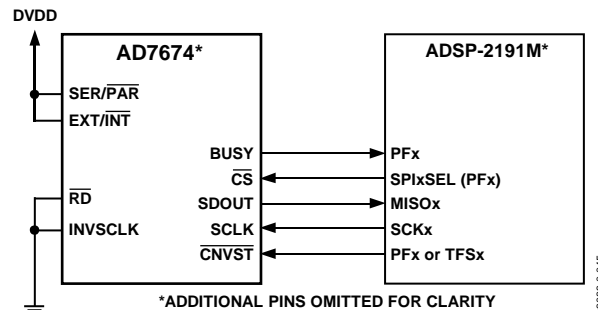

Figure 46. Interfacing the AD7674 to an SPI Interface

APPLICATIONS INFORMATION

LAYOUT

The [AD7674](#) has very good immunity to noise on the power supplies. However, care should still be taken with regard to grounding layout.

The printed circuit board that houses the [AD7674](#) should be designed so that the analog and digital sections are separated and confined to certain areas of the board. This calls for the use of ground planes, which can be easily separated. Digital and analog ground planes should be joined in only one place, preferably underneath the [AD7674](#), or at least as close to the [AD7674](#) as possible. If the [AD7674](#) is in a system where multiple devices require analog-to-digital ground connections, the connection should still be made at one point only, a star ground point that should be established as close to the [AD7674](#) as possible.

The user should avoid running digital lines under the device, as these couple noise onto the die. The analog ground plane should be allowed to run under the [AD7674](#) to avoid noise coupling. Fast switching signals like [CNVST](#) or clocks should be shielded with digital ground to avoid radiating noise to other sections of the board, and should never run near analog signal paths. Crossover of digital and analog signals should be avoided. Traces on different but close layers of the board should run at right angles to each other. This reduces the effect of feedthrough through the board. The power supply lines to the [AD7674](#) should use as large a trace as possible to provide low impedance paths and reduce the effect of glitches on the power supply lines. Good decoupling is also important to lower the impedance of the supply presented to the [AD7674](#) and to reduce the magnitude of the supply spikes. Decoupling ceramic capacitors, typically 100 nF, should be placed close to and ideally right up against each power supply pin (AVDD, DVDD, and OVDD) and their corresponding ground pins. Additionally, low ESR 10 μ F capacitors should be located near the ADC to further reduce low frequency ripple.

The DVDD supply of the [AD7674](#) can be a separate supply or can come from the analog supply, AVDD, or the digital interface supply, OVDD. When the system digital supply is noisy or when fast switching digital signals are present, and if no separate supply is available, the user should connect the DVDD digital supply to the analog supply AVDD through an

RC filter (see Figure 28) and connect the system supply to the interface digital supply OVDD and the remaining digital circuitry. When DVDD is powered from the system supply, it is useful to insert a bead to further reduce high frequency spikes.

The [AD7674](#) has four different ground pins: REFGND, AGND, DGND, and OGND. REFGND senses the reference voltage and should be a low impedance return to the reference because it carries pulsed currents. AGND is the ground to which most internal ADC analog signals are referenced. This ground must be connected with the least resistance to the analog ground plane. DGND must be tied to the analog or digital ground plane depending on the configuration. OGND is connected to the digital system ground.

The layout of the decoupling of the reference voltage is important. The decoupling capacitor should be close to the ADC and should be connected with short and large traces to minimize parasitic inductances.

EVALUATING [AD7674](#) PERFORMANCE

An evaluation board for the [AD7674](#) allows a quick means to measure both DC (histograms and time domain) and AC (time and frequency domain) performances of the converter. The [EVAL-AD7674CBZ](#) is an evaluation board package that includes a fully assembled and tested evaluation board, documentation, and software. The accompanying software requires the use of a capture board which must be ordered separately from the evaluation board (see the Ordering Guide for information). The evaluation board can also be used in a standalone configuration and does not use the software when in this mode. Refer to the [EVAL-AD76XXEDZ](#) and [EVAL-AD76XXCBZ](#) for evaluation board details.

Two types of data capture boards can be used with the [EVAL-AD7674CBZ](#):

- USB based ([EVAL-CED1Z](#) recommended)
- Parallel port based ([EVAL-CONTROL BRD3Z](#) not recommended as many newer PCs do not include parallel ports any longer)

The recommended board layout for the [AD7674](#) is outlined in the evaluation board data sheet.

OUTLINE DIMENSIONS

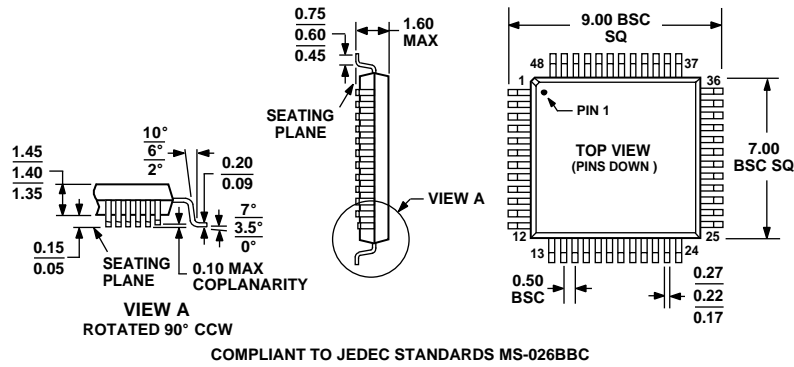

COMPLIANT TO JEDEC STANDARDS MS-026BBC
 Figure 47. 48-Lead Low Profile Quad Flat Package [LQFP] (ST-48)
 Dimensions shown in millimeters

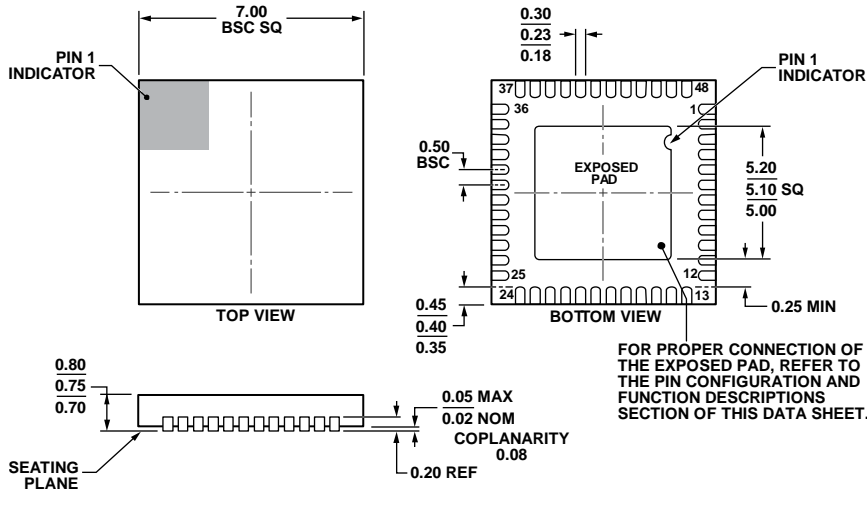

COMPLIANT TO JEDEC STANDARDS MO-220-WKGD.
 Figure 48. 48-Lead Lead Frame Chip Scale Package [LF CSP] 7 mm x 7 mm Body and 0.75 mm Package Height (CP-48-4)
 Dimensions shown in millimeters

ORDERING GUIDE

Model ^{1, 2, 3}	Temperature Range	Package Description	Package Option
AD7674ASTZ	-40°C to +85°C	48-Lead Low Profile Quad Flat Package [LQFP]	ST-48
AD7674ASTZL	-40°C to +85°C	48-Lead Low Profile Quad Flat Package [LQFP]	ST-48
AD7674ACPZ	-40°C to +85°C	48-Lead Lead Frame Chip Scale Package [LF CSP]	CP-48-4
AD7674ACPZRL	-40°C to +85°C	48-Lead Lead Frame Chip Scale Package [LF CSP]	CP-48-4
EVAL-AD7674CBZ		Evaluation Board	
EVAL-CED1Z		USB Data Capture Board	
EVAL-CONTROL BRD2Z		Parallel Port Capture Board, 32 k RAM	
EVAL-CONTROL BRD3Z		Parallel Port Capture Board, 128 k RAM	

¹ Z = RoHS Compliant Part.

²The EVAL-AD7674CBZ can be used as a standalone evaluation board or in conjunction with a capture board for evaluation/demonstration purposes.

³The capture boards allow the PC to control and communicate with all Analog Devices evaluation boards ending in ED for EVAL-CED1Z and CB for EVAL-CONTROL BRD2Z/EVAL-CONTROL BRD3Z.

NOTES

NOTES

Looking for pricing, stock, or lifecycle information?

Click below to explore more details on WIN SOURCE:

 [View AD7674ASTZRL on WIN SOURCE](#)

 [Analog Devices Inc. Information](#)

Optimize Your Supply Chain with WIN SOURCE Solutions

-  Global Sourcing Solution
-  Obsolete Management
-  Cost Control Management
-  Shortage Management
-  Alternative Solution
-  Excess Inventory Management