



**THE DATASHEET OF
AD9689BBPZ-2600**



FEATURES

JESD204B (Subclass 1) coded serial digital outputs

Support for lane rates up to 16 Gbps per lane

Noise density

–152 dBFS/Hz at 2.56 GSPS at full-scale voltage = 1.7 V p-p

–154 dBFS/Hz at 2.56 GSPS at full-scale voltage = 2.0 V p-p

–154.2 dBFS/Hz at 2.0 GSPS at full-scale voltage = 1.7 V p-p

–155.3 dBFS/Hz at 2.0 GSPS at full-scale voltage = 2.0 V p-p

1.55 W total power per channel at 2.56 GSPS (default settings)

SFDR at 2.56 GSPS encode

73 dBFS at 1.8 GHz A_{IN} at –2.0 dBFS

59 dBFS at 5.53 GHz A_{IN} at –2.0 dBFS

full-scale voltage = 1.1 V p-p

SNR at 2.56 GSPS encode

59.7 dBFS at 1.8 GHz A_{IN} at –2.0 dBFS

53.0 dBFS at 5.53 GHz A_{IN} at –2.0 dBFS

full-scale voltage = 1.1 V p-p

SFDR at 2.0 GSPS encode

78 dBFS at 900 MHz A_{IN} at –2.0 dBFS

62 dBFS at 5.53 GHz A_{IN} at –2.0 dBFS

full-scale voltage = 1.1 V p-p

SNR at 2.0 GSPS encode

62.7 dBFS at 900 MHz A_{IN} at –2.0 dBFS

53.1 dBFS at 5.5 GHz A_{IN} at –2.0 dBFS

full-scale voltage = 1.1 V p-p

0.975 V, 1.9 V, and 2.5 V dc supply operation

9 GHz analog input full power bandwidth (–3 dB)

Amplitude detect bits for efficient AGC implementation

Programmable FIR filters for analog channel loss equalization

2 integrated, wideband digital processors per channel

48-bit NCO

Programmable decimation rates

Phase coherent NCO switching

Up to 4 channels available

Serial port control

Supports 100 MHz SPI writes and 50 MHz SPI reads

Integer clock with divide by 2 and divide by 4 options

Flexible JESD204B lane configurations

On-chip dither

APPLICATIONS

Diversity multiband and multimode digital receivers

3G/4G, TD-SCDMA, W-CDMA, and GSM, LTE, LTE-A

Electronic test and measurement systems

Phased array radar and electronic warfare

DOCSIS 3.0 CMTS upstream receive paths

HFC digital reverse path receivers

FUNCTIONAL BLOCK DIAGRAM

Figure 1.

Rev. A

[Document Feedback](#)

Information furnished by Analog Devices is believed to be accurate and reliable. However, no responsibility is assumed by Analog Devices for its use, nor for any infringements of patents or other rights of third parties that may result from its use. Specifications subject to change without notice. No license is granted by implication or otherwise under any patent or patent rights of Analog Devices. Trademarks and registered trademarks are the property of their respective owners.

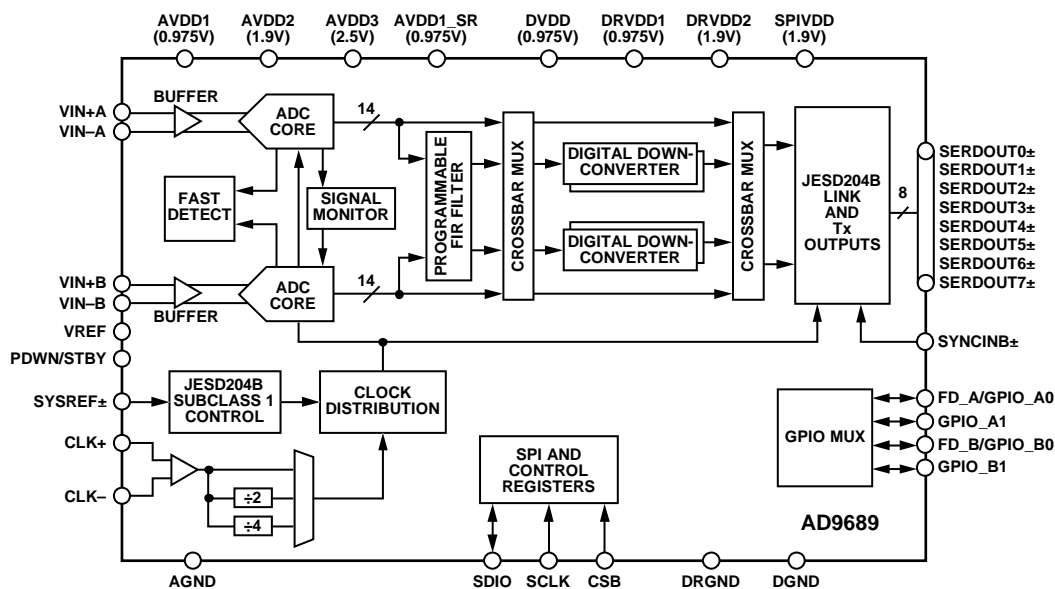
One Technology Way, P.O. Box 9106, Norwood, MA 02062-9106, U.S.A.

Tel: 781.329.4700

©2017 Analog Devices, Inc. All rights reserved.

[Technical Support](#)
www.analog.com

TABLE OF CONTENTS

Features	1	DDC Frequency Translation.....	47
Applications.....	1	DDC Decimation Filters	55
Functional Block Diagram	1	DDC Gain Stage	61
Revision History	3	DDC Complex to Real Conversion	61
General Description	4	DDC Mixed Decimation Settings	62
Product Highlights	4	DDC Example Configurations	64
Specifications.....	5	DDC Power Consumption.....	67
DC Specifications	5	Signal Monitor	68
AC Specifications.....	6	SPORT over JESD204B.....	69
Digital Specifications	8	Digital Outputs	71
Switching Specifications	9	Introduction to the JESD204B Interface	71
Timing Specifications	10	JESD204B Overview	71
Absolute Maximum Ratings.....	12	Functional Overview	72
Thermal Resistance	12	JESD204B Link Establishment	72
ESD Caution.....	12	Physical Layer (Driver) Outputs	74
Pin Configuration and Function Descriptions.....	13	f _S × 4 Mode	75
Typical Performance Characteristics	16	Setting Up the AD9689 Digital Interface.....	76
2.0 GSPS.....	16	Deterministic Latency.....	83
2.6 GSPS.....	21	Subclass 0 Operation.....	83
Equivalent Circuits	26	Subclass 1 Operation.....	83
Theory of Operation	28	Multichip Synchronization.....	85
ADC Architecture	28	Normal Mode.....	85
Analog Input Considerations.....	28	Timestamp Mode	85
Voltage Reference	31	SYSREF Input.....	87
DC Offset Calibration.....	32	SYSREF± Setup/Hold Window Monitor.....	89
Clock Input Considerations	32	Latency.....	91
Power-Down and Standby Mode	35	End to End Total Latency.....	91
Temperature Diode	35	Example Latency Calculations.....	91
ADC Overrange and Fast Detect.....	37	LMFC Referenced Latency.....	91
ADC Overrange.....	37	Test Modes.....	93
Fast Threshold Detection (FD_A and FD_B)	37	ADC Test Modes	93
ADC Application Modes and JESD204B Tx Converter Mapping	38	JESD204B Block Test Modes	94
Programmable FIR Filters	40	Serial Port Interface.....	96
Supported Modes.....	40	Configuration Using the SPI.....	96
Programming Instructions.....	42	Hardware Interface.....	96
Digital Downconverter (DDC).....	44	SPI Accessible Features.....	96
DDC I/Q Input Selection	44	Memory Map	97
DDC I/Q Output Selection	44	Reading the Memory Map Register Table.....	97
DDC General Description	44	Memory Map Register Details.....	98
		Applications Information	132

Power Supply Recommendations	132
Layout Guidelines	133
AVDD1_SR (Pin E7) and AGND (Pin E6 and Pin E8).....	133

Outline Dimensions.....	134
Ordering Guide	134

REVISION HISTORY

10/2017—Rev. 0 to Rev. A

Added 2.0 GSPS.....	Throughout
Changes to Features Section	1
Changes to Product Highlights Section	4
Changes to Table 1	5
Changes to Table 2	6
Changes to Table 4	9
Added 2.0 GSPS Section and Figure 6 to Figure 11; Renumbered Sequentially	16
Added Figure 12 to Figure 17	17
Added Figure 18 to Figure 23	18
Added Figure 24 through Figure 29.....	19
Added Figure 30 through Figure 35.....	20
Added 2.6 GSPS Section.....	21
Change to Figure 41	21
Change to Figure 45	22
Changes to Figure 52 and Figure 53	23
Changes to Figure 54, Figure 55, Figure 56, Figure 58, and Figure 59	24
Changes to Figure 60 and Figure 61	25

Changes to Figure 67 Caption	26
Changes to Table 10	30
Changes to Figure 87	32
Changes to Figure 96 Caption	35
Changes to Programming Instructions Section.....	42
Added Table 28; Renumbered Sequentially.....	67
Changes to Table 29 Title	67
Changes to De-Emphasis Section	74
Changes to Figure 142	82
Changes to Reading the Memory Map Register Table Section.....	97
Changes to Address 0x0006, Table 46	98
Changes to Address 0x010A, Table 47	99
Changes to Table 50	105
Changes to Table 51	117
Changes to Power Supply Recommendations Section, Figure 157, and Figure 158	132
Changes to Ordering Guide.....	134

9/2017—Revision 0: Initial Version

GENERAL DESCRIPTION

The AD9689 is a dual, 14-bit, 2.0 GSPS/2.6 GSPS analog-to-digital converter (ADC). The device has an on-chip buffer and a sample-and-hold circuit designed for low power, small size, and ease of use. This product is designed to support communications applications capable of direct sampling wide bandwidth analog signals of up to 5 GHz. The -3 dB bandwidth of the ADC input is 9 GHz. The AD9689 is optimized for wide input bandwidth, high sampling rate, excellent linearity, and low power in a small package.

The dual ADC cores feature a multistage, differential pipelined architecture with integrated output error correction logic. Each ADC features wide bandwidth inputs supporting a variety of user-selectable input ranges. An integrated voltage reference eases design considerations. The analog input and clock signals are differential inputs. The ADC data outputs are internally connected to four digital downconverters (DDCs) through a crossbar mux. Each DDC consists of multiple cascaded signal processing stages: a 48-bit frequency translator (numerically controlled oscillator (NCO)), and decimation rates. The NCO has the option to select preset bands over the general-purpose input/output (GPIO) pins, which enables the selection of up to three bands. Operation of the AD9689 between the DDC modes is selectable via SPI-programmable profiles.

In addition to the DDC blocks, the AD9689 has several functions that simplify the automatic gain control (AGC) function in a communications receiver. The programmable threshold detector allows monitoring of the incoming signal power using the fast detect control bits in Register 0x0245 of the ADC. If the input signal level exceeds the programmable threshold, the fast detect indicator goes high. Because this threshold indicator has low latency, the user can quickly turn down the system gain to avoid an overrange condition at the ADC input. In addition to the fast detect outputs, the AD9689 also offers signal monitoring capability. The signal monitoring block provides additional information about the signal being digitized by the ADC.

The user can configure the Subclass 1 JESD204B-based high speed serialized output in a variety of one-lane, two-lane, four-lane, and eight-lane configurations, depending on the DDC configuration and the acceptable lane rate of the receiving logic device. Multidevice synchronization is supported through the $\text{SYSREF}\pm$ and $\text{SYNCINB}\pm$ input pins.

The AD9689 has flexible power-down options that allow significant power savings when desired. All of these features can be programmed using a 3-wire serial port interface (SPI).

The AD9689 is available in a Pb-free, 196-ball BGA, specified over the -40°C to $+85^{\circ}\text{C}$ ambient temperature range. This product is protected by a U.S. patent.

Note that throughout this data sheet, multifunction pins, such as $\text{FD_A}/\text{GPIO_A0}$, are referred to either by the entire pin name or by a single function of the pin, for example, FD_A , when only that function is relevant.

PRODUCT HIGHLIGHTS

1. Wide, input -3 dB bandwidth of 9 GHz supports direct radio frequency (RF) sampling of signals up to about 5 GHz.
2. Four integrated, wideband decimation filters and NCO blocks supporting multiband receivers.
3. Fast NCO switching enabled through the GPIO pins.
4. SPI controls various product features and functions to meet specific system requirements.
5. Programmable fast overrange detection and signal monitoring.
6. On-chip temperature diode for system thermal management.
7. 12 mm \times 12 mm, 196-ball BGA.
8. Pin, package, feature, and memory map compatible with the [AD9208](#) 14-bit, 3.0 GSPS, JESD204B dual ADC.

SPECIFICATIONS

DC SPECIFICATIONS

AVDD1 = 0.975 V, AVDD1_SR = 0.975 V, AVDD2 = 1.9 V, AVDD3 = 2.5 V, DVDD = 0.975 V, DRVDD1 = 0.975 V, DRVDD2 = 1.9 V, SPIVDD = 1.9 V, sampling rate = 2.0 GHz/2.56 GHz, clock divider = 2, 1.7 V p-p full-scale differential input, input amplitude (A_{IN}) = -2.0 dBFS, L = 8, M = 2, F = 1, $-10^{\circ}\text{C} \leq T_J \leq +120^{\circ}\text{C}$,¹ unless otherwise noted. Typical specifications represent performance at $T_J = 70^{\circ}\text{C}$ ($T_A = 25^{\circ}\text{C}$).

Table 1.

Parameter	2.0 GSPS			2.6 GSPS			Unit
	Min	Typ	Max	Min	Typ	Max	
RESOLUTION	14			14			Bits
ACCURACY							
No Missing Codes		Guaranteed			Guaranteed		
Offset Error				0			%FSR
Offset Matching		0		0			%FSR
Gain Error	-2.9	±1	+1.8	-4.9	±1	+5.6	%FSR
Gain Matching		±0.2			±0.2		%FSR
Differential Nonlinearity (DNL)	-0.62	±0.4	+0.79	-0.65	±0.4	+0.75	LSB
Integral Nonlinearity (INL)	-9.9	±2	+8.1	-16	±6	+13	LSB
TEMPERATURE DRIFT							
Offset Error		±7.7			±3.7		ppm/°C
Gain Error		15			58		ppm/°C
INTERNAL VOLTAGE REFERENCE		0.5			0.5		V
INPUT REFERRED NOISE		3.8			4.6		LSB rms
ANALOG INPUTS							
Differential Input Voltage Range	1.1	1.7	2.0	1.1	1.7	2.0	V p-p
Common-Mode Voltage (V_{CM})		1.4			1.4		V
Differential Input Capacitance		0.35			0.35		pF
-3 dB Bandwidth		9			9		GHz
POWER SUPPLY							
AVDD1	0.95	0.975	1.0	0.95	0.975	1.0	V
AVDD2	1.85	1.9	1.95	1.85	1.9	1.95	V
AVDD3	2.44	2.5	2.56	2.44	2.5	2.56	V
AVDD1_SR	0.95	0.975	1.0	0.95	0.975	1.0	V
DVDD	0.95	0.975	1.0	0.95	0.975	1.0	V
DRVDD1	0.95	0.975	1.0	0.95	0.975	1.0	V
DRVDD2	1.85	1.9	1.95	1.85	1.9	1.95	V
SPIVDD	1.85	1.9	1.95	1.85	1.9	1.95	V
I_{AVDD1}		455	605		590	693	mA
I_{AVDD2}		585	670		810	882	mA
I_{AVDD3}		65	72		65	73	mA
I_{AVDD1_SR}		25	41		25	43	mA
I_{DVDD}		340	800		405	833	mA
I_{DRVDD1}^2		320	432		390	500	mA
I_{DRVDD2}		25	30		25	30	mA
I_{SPIVDD}		1	5		1	5	mA

POWER CONSUMPTION			
Total Power Dissipation (Including Output Drivers) ³	2.45	3.1	W
Power-Down Dissipation	265	300	mW
Standby ⁴	1.3	1.5	W

¹ The junction temperature (T_J) range of -10°C to $+120^\circ\text{C}$ translates to an ambient temperature (T_A) range of -40°C to $+85^\circ\text{C}$.

² All lanes running. Power dissipation on DRVDDx changes with lane rate and number of lanes used.

³ Default mode. No DDCs used.

⁴ Can be controlled by the SPI.

AC SPECIFICATIONS

AVDD1 = 0.975 V, AVDD1_SR = 0.975 V, AVDD2 = 1.9 V, AVDD3 = 2.5 V, DVDD = 0.975 V, DRVDD1 = 0.975 V, DRVDD2 = 1.9 V, SPIVDD = 1.9 V, sampling rate = 2.0 GHz/2.56 GHz, clock divider = 2, 1.7 V p-p full-scale differential input, input amplitude (A_{IN}) = -2.0 dBFS, default SPI settings, $-10^\circ\text{C} \leq T_J \leq +120^\circ\text{C}$,¹ unless otherwise noted. Typical specifications represent performance at $T_J = 70^\circ\text{C}$ ($T_A = 25^\circ\text{C}$).

Table 2.

Parameter ²	2.0 GSPS			2.6 GSPS			Unit
	Min	Typ	Max	Min	Typ	Max	
NOISE DENSITY ³							
Full Scale = 1.7 V p-p		-154.2			-152		dBFS/Hz
Full Scale = 2.0 V p-p		-155.3			-154		dBFS/Hz
CODE ERROR RATE (CER)							
AVDD1 = 0.975 V		7×10^{-15}			9×10^{-9}		Errors
AVDD1 = 1.0 V		3×10^{-15}			4.5×10^{-10}		Errors
SIGNAL-TO-NOISE RATIO (SNR)							
$f_{IN} = 155$ MHz		63.7			61.3		dBFS
$f_{IN} = 155$ MHz (Full Scale = 2.0 V p-p)		65.0			62.5		dBFS
$f_{IN} = 750$ MHz		63.1			61.0		dBFS
$f_{IN} = 900$ MHz	60.2	62.7			60.9		dBFS
$f_{IN} = 1800$ MHz		60.9		56.0	59.7		dBFS
$f_{IN} = 2100$ MHz		59.9			59.3		dBFS
$f_{IN} = 3300$ MHz		58.3			58.0		dBFS
$f_{IN} = 4350$ MHz (Full Scale = 1.1 V p-p)		54.4			54.0		dBFS
$f_{IN} = 5530$ MHz (Full Scale = 1.1 V p-p)		53.1			53.0		dBFS
SIGNAL-TO-NOISE-AND-DISTORTION RATIO (SINAD)							
$f_{IN} = 155$ MHz		63.5			61.2		dBFS
$f_{IN} = 155$ MHz (Full Scale = 2.0 V p-p)		64.7			62.4		dBFS
$f_{IN} = 750$ MHz		62.8			60.7		dBFS
$f_{IN} = 900$ MHz	59.6	62.5			60.5		dBFS
$f_{IN} = 1800$ MHz		60.8		52.4	59.4		dBFS
$f_{IN} = 2100$ MHz		59.7			59.1		dBFS
$f_{IN} = 3300$ MHz		55.3			56.6		dBFS
$f_{IN} = 4350$ MHz (Full Scale = 1.1 V p-p)		53.2			51.0		dBFS
$f_{IN} = 5530$ MHz (Full Scale = 1.1 V p-p)		52.3			49.5		dBFS
EFFECTIVE NUMBER OF BITS (ENOB)							
$f_{IN} = 155$ MHz		10.3			9.9		Bits
$f_{IN} = 155$ MHz (Full Scale = 2.0 V p-p)		10.5			10.1		Bits
$f_{IN} = 750$ MHz		10.1			9.8		Bits
$f_{IN} = 900$ MHz	9.6	10.1			9.8		Bits
$f_{IN} = 1800$ MHz		9.8		8.4	9.6		Bits
$f_{IN} = 2100$ MHz		9.6			9.5		Bits
$f_{IN} = 3300$ MHz		8.9			9.1		Bits
$f_{IN} = 4350$ MHz (Full Scale = 1.1 V p-p)		8.6			8.2		Bits
$f_{IN} = 5530$ MHz (Full Scale = 1.1 V p-p)		8.4			7.9		Bits

Parameter ²	2.0 GSPS			2.6 GSPS			Unit
	Min	Typ	Max	Min	Typ	Max	
SPURIOUS FREE DYNAMIC RANGE (SFDR), SECOND OR THIRD HARMONIC ^{4,5}							
$f_{IN} = 155$ MHz		77			78		dBFS
$f_{IN} = 155$ MHz (Full Scale = 2.0 V p-p)		77			78		dBFS
$f_{IN} = 750$ MHz		77			73		dBFS
$f_{IN} = 900$ MHz	66	78			74		dBFS
$f_{IN} = 1800$ MHz		76		58	73		dBFS
$f_{IN} = 2100$ MHz		76			73		dBFS
$f_{IN} = 3300$ MHz		60			64		dBFS
$f_{IN} = 4350$ MHz (Full Scale = 1.1 V p-p)		61			60		dBFS
$f_{IN} = 5530$ MHz (Full Scale = 1.1 V p-p)		62			59		dBFS
WORST OTHER, EXCLUDING SECOND OR THIRD HARMONIC							
$f_{IN} = 155$ MHz		-99			-96		dBFS
$f_{IN} = 155$ MHz (Full Scale = 2.0 V p-p)		-95			-98		dBFS
$f_{IN} = 750$ MHz		-100			-97		dBFS
$f_{IN} = 900$ MHz		-94	-80		-96		dBFS
$f_{IN} = 1800$ MHz		-91			-88	-74	dBFS
$f_{IN} = 2100$ MHz		-86			-94		dBFS
$f_{IN} = 3300$ MHz		-85			-85		dBFS
$f_{IN} = 4350$ MHz (Full Scale = 1.1 V p-p)		-83			-84		dBFS
$f_{IN} = 5530$ MHz (Full Scale = 1.1 V p-p)		-82			-82		dBFS
TWO-TONE INTERMODULATION DISTORTION (IMD), A_{IN1} AND $A_{IN2} = -8.0$ dBFS							
$f_{IN1} = 1841$ MHz, $f_{IN2} = 1846$ MHz		-72			-72		dBFS
$f_{IN1} = 2137$ MHz, $f_{IN2} = 2142$ MHz		-74			-76		dBFS
CROSSTALK ⁶		>90			>90		dB
ANALOG INPUT BANDWIDTH, FULL POWER ⁷		5			5		GHz

¹ The junction temperature (T_J) range of -10°C to $+120^\circ\text{C}$ translates to an ambient temperature (T_A) range of -40°C to $+85^\circ\text{C}$.

² See [AN-835](#) for definitions and for details on how these tests were completed.

³ Noise density is measured at a low analog input frequency (30 MHz).

⁴ The input configuration component values are found in Table 9. Refer to Table 10 for the recommended buffer settings.

⁵ Figure 79 shows the differential transformer coupled configuration. Figure 80 is the input network configuration for frequencies > 5 GHz.

⁶ Crosstalk is measured at 950 MHz with a -2.0 dBFS analog input on one channel, and no input on the adjacent channel.

⁷ Full power bandwidth is the bandwidth of operation in which proper ADC performance can be achieved.

DIGITAL SPECIFICATIONS

AVDD1 = 0.975 V, AVDD1_SR = 0.975 V, AVDD2 = 1.9 V, AVDD3 = 2.5 V, DVDD = 0.975 V, DRVDD1 = 0.975 V, DRVDD2 = 1.9 V, SPIVDD = 1.9 V, $-10^{\circ}\text{C} \leq T_j \leq +120^{\circ}\text{C}$,¹ unless otherwise noted. Typical specifications represent performance at $T_j = 70^{\circ}\text{C}$ ($T_A = 25^{\circ}\text{C}$).

Table 3.

Parameter	Min	Typ	Max	Unit
CLOCK INPUTS (CLK+, CLK–)				
Logic Compliance		LVDS/LVPECL		
Differential Input Voltage	300	800	1800	mV p-p
Input Common-Mode Voltage		0.675		V
Input Resistance (Differential)		106		Ω
Input Capacitance		0.9		pF
Differential Input Return Loss at 2.6 GHz ²		9.4		dB
SYSTEM REFERENCE (SYSREF) INPUTS (SYSREF+, SYSREF–)				
Logic Compliance		LVDS/LVPECL		
Differential Input Voltage	400	800	1800	mV p-p
Input Common-Mode Voltage		0.675	2.0	V
Input Resistance (Differential)		18		k Ω
Input Capacitance (Differential)		1		pF
LOGIC INPUTS (SDIO, SCLK, CSB, PDWN/STBY, FD_A/GPIO_A0, FD_B/GPIO_B0, GPIO_A1, GPIO_B1)				
Logic Compliance		CMOS		
Logic 1 Voltage	$0.65 \times \text{SPIVDD}$			V
Logic 0 Voltage	0		$0.35 \times \text{SPIVDD}$	V
Input Resistance		30		k Ω
LOGIC OUTPUTS (SDIO, FD_A, FD_B)				
Logic Compliance		CMOS		
Logic 1 Voltage ($I_{OH} = 4 \text{ mA}$)	$\text{SPIVDD} - 0.45\text{V}$			V
Logic 0 Voltage ($I_{OL} = 4 \text{ mA}$)	0		0.45	V
SYNCHRONIZATION INPUT (SYNCINB+/SYNCINB–)				
Logic Compliance		LVDS/LVPECL		
Differential Input Voltage	400	800	1800	mV p-p
Input Common-Mode Voltage		0.675	2.0	V
Input Resistance (Differential)		18		k Ω
Input Capacitance		1		pF
SYNCINB+ INPUT				
Logic Compliance		CMOS		
Logic 1 Voltage	$0.9 \times \text{DRVDD1}$		$2 \times \text{DRVDD1}$	V
Logic 0 Voltage			$0.1 \times \text{DRVDD1}$	V
Input Resistance		2.6		k Ω
DIGITAL OUTPUTS (SERDOUTx_{\pm}, $x = 0$ TO 7)				
Logic Compliance		SST		
Differential Output Voltage	360	560	770	mV p-p
Differential Termination Impedance	80	100	120	Ω

¹ The junction temperature (T_j) range of -10°C to $+120^{\circ}\text{C}$ translates to an ambient temperature (T_A) range of -40°C to $+85^{\circ}\text{C}$.

² Reference impedance = 100 Ω .

SWITCHING SPECIFICATIONS

AVDD1 = 0.975 V, AVDD1_SR = 0.975 V, AVDD2 = 1.9 V, AVDD3 = 2.5 V, DVDD = 0.975 V, DRVDD1 = 0.975 V, DRVDD2 = 1.9 V, SPIVDD = 1.9 V, default SPI settings, $-10^{\circ}\text{C} \leq T_j \leq +120^{\circ}\text{C}$,¹ unless otherwise noted. Typical specifications represent performance at $T_j = 70^{\circ}\text{C}$ ($T_A = 25^{\circ}\text{C}$).

Table 4.

Parameter	2.0 GSPS			2.6 GSPS			Unit
	Min	Typ	Max	Min	Typ	Max	
CLOCK							
Clock Rate at CLK+/CLK– Pins			6			6	GHz
Sample Rate ²	1200	2000	2100	1900	2600	2700	MSPS
Clock Pulse Width High	238.096			185.185			ps
Clock Pulse Width Low	238.096			185.185			ps
OUTPUT PARAMETERS							
Unit Interval (UI) ³	62.5	66.67	592.6	62.5	66.67	592.6	ps
Rise Time (t_R) (20% to 80% into 100 Ω Load)		26			26		ps
Fall Time (t_F) (20% to 80% into 100 Ω Load)		26			26		ps
Phase-Locked Loop (PLL) Lock Time		5			5		ms
Data Rate per Channel (Nonreturn to Zero) ⁴	1.6875	13	16	1.6875	13	16	Gbps
LATENCY⁵							
Pipeline Latency ⁶		75			75		Clock cycles
Fast Detect Latency		26			26		Clock cycles
NCO Channel Selection to Output			8			8	Clock cycles
WAKE-UP TIME							
Standby		400			400		μs
Power-Down		15			15		ms
APERTURE							
Delay (t_A)		250			250		ps
Uncertainty (Jitter, t_j)		55			55		fs rms
Out of Range Recovery Time		1			1		Clock cycles

¹ The junction temperature (T_j) range of -10°C to $+120^{\circ}\text{C}$ translates to an ambient temperature (T_A) range of -40°C to $+85^{\circ}\text{C}$.

² The maximum sample rate is the clock rate after the divider.

³ Baud rate = $1/\text{UI}$. A subset of this range can be supported.

⁴ Default L = 8. This number can be changed based on the sample rate and decimation ratio.

⁵ No DDCs used. L = 8, M = 2, and F = 1.

⁶ Refer to the Latency section for more details.

TIMING SPECIFICATIONS

Table 5.

Parameter	Description	Min	Typ	Max	Unit
CLK+ to SYSREF+ TIMING REQUIREMENTS					
t_{SU_SR}	Device clock to SYSREF+ setup time		-65		ps
t_{H_SR}	Device clock to SYSREF+ hold time		95		ps
SPI TIMING REQUIREMENTS					
t_{DS}	Setup time between the data and the rising edge of SCLK	2			ns
t_{DH}	Hold time between the data and the rising edge of SCLK	2			ns
t_{CLK} for SPI Reads	Period of the SCLK	20			ns
t_{CLK} for SPI Writes	Period of the SCLK	10			ns
t_S	Setup time between CSB and SCLK	2			ns
t_H	Hold time between CSB and SCLK	2			ns
t_{HIGH} for SPI Reads	Minimum period that SCLK must be in a logic high state	8			ns
t_{HIGH} for SPI Writes	Minimum period that SCLK must be in a logic high state	4			ns
t_{LOW} for SPI Reads	Minimum period that SCLK must be in a logic low state	8			ns
t_{LOW} for SPI Writes	Minimum period that SCLK must be in a logic low state	4			ns
t_{ACCESS}	Maximum time delay between the falling edge of SCLK and output data valid for a read operation		5	8	ns
t_{DIS_SDIO}	Time required for the SDIO pin to switch from an output to an input, relative to the SCLK rising edge (not shown in Figure 4)	2			ns

Timing Diagrams

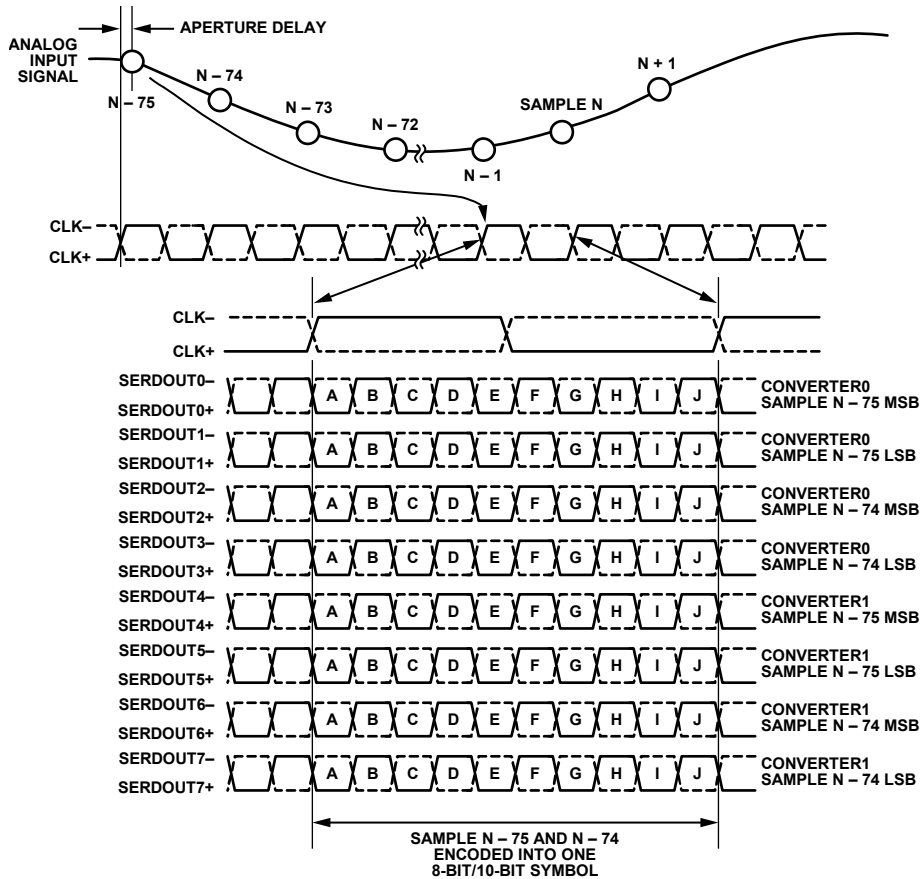

Figure 2. Data Output Timing Diagram

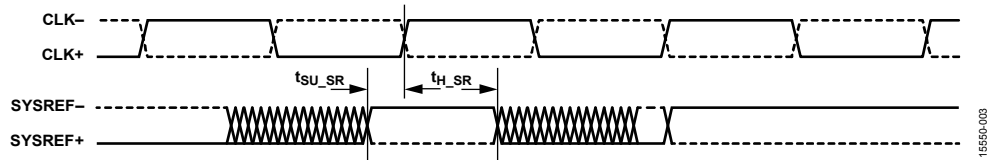

Figure 3. CLK+ to SYSREF+ Setup and Hold Timing Diagram

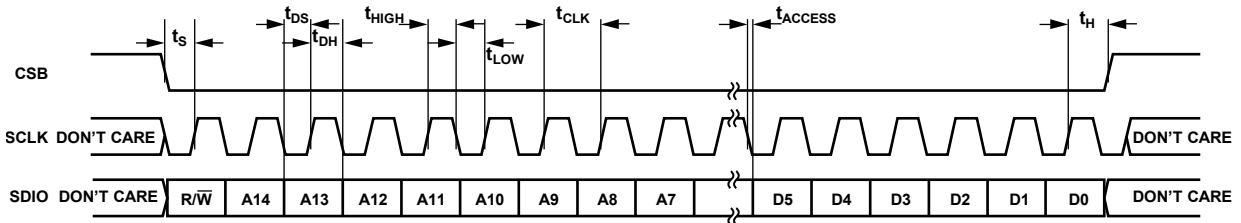

Figure 4. SPI Interface Timing Diagram

ABSOLUTE MAXIMUM RATINGS

Table 6.

Parameter	Rating
Electrical	
AVDD1 to AGND	1.05 V
AVDD1_SR to AGND	1.05 V
AVDD2 to AGND	2.0 V
AVDD3 to AGND	2.70 V
DVDD to DGND	1.05 V
DRVDD1 to DRGND	1.05 V
DRVDD2 to DRGND	2.0 V
SPIVDD to DGND	2.0 V
AGND to DRGND	-0.3 V to +0.3 V
AGND to DGND	-0.3 V to +0.3 V
DGND to DRGND	-0.3 V to +0.3 V
VIN±x to AGND	AGND - 0.3 V to AVDD3 + 0.3 V
CLK± to AGND	AGND - 0.3 V to AVDD1 + 0.3 V
SCLK, SDIO, CSB to DGND	DGND - 0.3 V to SPIVDD + 0.3 V
PDWN/STBY to DGND	DGND - 0.3 V to SPIVDD + 0.3 V
SYSREF± to AGND	2.5 V
SYNCINB± to DRGND	2.5 V
Junction Temperature Range (T _J)	-40°C to +125°C
Storage Temperature Range, Ambient (T _A)	-65°C to +150°C

Stresses at or above those listed under Absolute Maximum Ratings may cause permanent damage to the product. This is a stress rating only; functional operation of the product at these or any other conditions above those indicated in the operational section of this specification is not implied. Operation beyond the maximum operating conditions for extended periods may affect product reliability.

THERMAL RESISTANCE

Thermal performance is directly linked to printed circuit board (PCB) design and operating environment. Close attention to PCB thermal design is required. θ_{JA} is the natural convection junction-to-ambient thermal resistance measured in a one cubic foot sealed enclosure. θ_{JC} is the junction to case thermal resistance.

Table 7. Thermal Resistance

Package Type	θ_{JA}	θ_{JC_TOP}	Ψ_{JB}	Unit
BP-196-4 ¹	16.26	1.4	5.44	°C/W

¹ Test Condition 1: Thermal impedance simulated values are based on JEDEC 252P thermal test board with 190 thermal vias. See JEDEC JESD51.

ESD CAUTION



ESD (electrostatic discharge) sensitive device. Charged devices and circuit boards can discharge without detection. Although this product features patented or proprietary protection circuitry, damage may occur on devices subjected to high energy ESD. Therefore, proper ESD precautions should be taken to avoid performance degradation or loss of functionality.

PIN CONFIGURATION AND FUNCTION DESCRIPTIONS

	1	2	3	4	5	6	7	8	9	10	11	12	13	14
A	AVDD2	AVDD2	AVDD1	AVDD1 ¹	AVDD1 ¹	AGND ¹	CLK+	CLK-	AGND ¹	AVDD1 ¹	AVDD1 ¹	AVDD1	AVDD2	AVDD2
B	AVDD2	AVDD2	AVDD1	AVDD1 ¹	AGND	AGND ¹	AGND ¹	AGND ¹	AGND ¹	AGND	AVDD1 ¹	AVDD1	AVDD2	AVDD2
C	AVDD2	AVDD2	AVDD1	AGND	AGND	AGND ¹	AGND ¹	AGND ¹	AGND ¹	AGND	AGND	AVDD1	AVDD2	AVDD2
D	AVDD3	AGND	AGND	AGND	AGND	AGND	AGND ¹	AGND ¹	AGND	AGND	AGND	AGND	AGND	AVDD3
E	VIN-B	AGND	AGND	AGND	AGND	AGND ²	AVDD1_SR	AGND ²	AGND	AGND	AGND	AGND	AGND	VIN-A
F	VIN+B	AGND	AGND	AGND	AGND	AGND	SYSREF+	SYSREF-	AGND	AGND	AGND	AGND	AGND	VIN+A
G	AVDD3	AGND	AGND	AGND	AGND	AGND	AGND	AGND	AGND	AGND	AGND	AGND	AGND	AVDD3
H	AGND	AGND	AGND	AGND	AGND	AGND	AGND	AGND	AGND	VREF	AGND	AGND	AGND	AGND
J	AGND	AGND	AGND	AGND	AGND	AGND	AGND	AGND	AGND	AGND	AGND	AGND	AGND	AGND
K	AGND ³	AGND ³	AGND ³	AGND ³	AGND ³	AGND ³	AGND ³	AGND ³	AGND ³	AGND ³	AGND ³	AGND ³	AGND ³	AGND ³
L	DGND	GPIO_B1	SPIVDD	FD_B/ GPIO_B0	CSB	SCLK	SDIO	PDWN/ STBY	FD_A/ GPIO_A0	SPIVDD	GPIO_A1	DGND	DGND	DGND
M	DGND	DGND	DRGND	DRGND	DRVDD1	DRVDD1	DRVDD1	DRVDD1	DRGND	DRGND	DRVDD1	DRGND	DRVDD2	DVDD
N	DVDD	DVDD	DRGND	SERDOUT7+	SERDOUT6+	SERDOUT5+	SERDOUT4+	SERDOUT3+	SERDOUT2+	SERDOUT1+	SERDOUT0+	DRGND	SYNCINB+	DVDD
P	DVDD	DVDD	DRGND	SERDOUT7-	SERDOUT6-	SERDOUT5-	SERDOUT4-	SERDOUT3-	SERDOUT2-	SERDOUT1-	SERDOUT0-	DRGND	SYNCINB-	DVDD

¹DENOTES CLOCK DOMAIN.
²DENOTES SYSREF± DOMAIN.
³DENOTES ISOLATION DOMAIN.

Figure 5. Pin Configuration (Top View)

15560-005

Table 8. Pin Function Descriptions¹

Pin No.	Mnemonic	Type	Description
Power Supplies			
A3, A12, B3, B12, C3, C12	AVDD1	Power	Analog Power Supply (0.975 V Nominal).
A4, A5, A10, A11, B4, B11	AVDD1 ²	Power	Analog Power Supply for the Clock Domain (0.975 V Nominal).
A1, A2, A13, A14, B1, B2, B13, B14, C1, C2, C13, C14	AVDD2	Power	Analog Power Supply (1.9 V Nominal).
D1, D14, G1, G14	AVDD3	Power	Analog Power Supply (2.5 V Nominal).
E7	AVDD1_SR	Power	Analog Power Supply for SYSREF± (0.975 V Nominal).
L3, L10	SPIVDD	Power	Digital Power Supply for SPI (1.9 V Nominal).
M14, N1, N2, N14, P1, P2, P14	DVDD	Power	Digital Power Supply (0.975 V Nominal).
M5 to M8, M11	DRVDD1	Power	Digital Driver Power Supply (0.975 V Nominal).
M13	DRVDD2	Power	Digital Driver Power Supply (1.9 V Nominal).
B5, B10, C4, C5, C10, C11, D2 to D6, D9 to D13, E2 to E5, E9 to E13, F2 to F6, F9 to F13, G2 to G13, H1 to H9, H11 to H14, J1 to J14	AGND	Ground	Analog Ground. These pins connect to the analog ground plane.
A6, A9, B6 to B9, C6 to C9, D7, D8	AGND ²	Ground	Ground Reference for the Clock Domain.
E6, E8	AGND ³	Ground	Ground Reference for SYSREF±.
K1 to K14	AGND ⁴	Ground	Isolation Ground.
L1, L12 to L14, M1, M2	DGND	Ground	Digital Control Ground Supply. These pins connect to the digital ground plane.
M3, M4, M9, M10, M12, N3, N12, P3, P12	DRGND	Ground	Digital Driver Ground Supply. These pins connect to the digital driver ground plane.
Analog			
E1, F1	VIN–B, VIN+B	Input	ADC B Analog Input Complement/True.
E14, F14	VIN–A, VIN+A	Input	ADC A Analog Input Complement/True.
A7, A8	CLK+, CLK–	Input	Clock Input True/Complement.
H10	VREF	Input/output/ do not connect (DNC)	0.50 V Reference Voltage Input/Do Not Connect. This pin is configurable through the SPI as a no connect or an input. Do not connect this pin if using the internal reference. This pin requires a 0.50 V reference voltage input if using an external voltage reference source.
CMOS Inputs/Outputs			
L2	GPIO_B1	Input/output	GPIO B1.
L4	FD_B/GPIO_B0	Input/output	Fast Detect Outputs for Channel B/GPIO B0.
L9	FD_A/GPIO_A0	Input/output	Fast Detect Outputs for Channel A/GPIO A0.
L11	GPIO_A1	Input/output	GPIO A1.
Digital Inputs			
F7, F8	SYSREF+, SYSREF–	Input	Active High JESD204B LVDS System Reference Input True/Complement.
N13	SYNCINB+	Input	Active Low JESD204B LVDS/CMOS Sync Input True.
P13	SYNCINB–	Input	Active Low JESD204B LVDS Sync Input Complement.
Data Outputs			
N4, P4	SERDOUT7+, SERDOUT7–	Output	Lane 7 Output Data True/Complement.
N5, P5	SERDOUT6+, SERDOUT6–	Output	Lane 6 Output Data True/Complement.
N6, P6	SERDOUT5+, SERDOUT5–	Output	Lane 5 Output Data True/Complement.
N7, P7	SERDOUT4+, SERDOUT4–	Output	Lane 4 Output Data True/Complement.
N8, P8	SERDOUT3+, SERDOUT3–	Output	Lane 3 Output Data True/Complement.
N9, P9	SERDOUT2+, SERDOUT2–	Output	Lane 2 Output Data True/Complement.
N10, P10	SERDOUT1+, SERDOUT1–	Output	Lane 1 Output Data True/Complement.
N11, P11	SERDOUT0+, SERDOUT0–	Output	Lane 0 Output Data True/Complement.

Pin No.	Mnemonic	Type	Description
Digital Controls			
L5	CSB	Input	SPI Chip Select (Active Low).
L6	SCLK	Input	SPI Serial Clock.
L7	SDIO	Input/output	SPI Serial Data Input/Output.
L8	PDWN/STBY	Input	Power-Down Input (Active High). The operation of this pin depends on the SPI mode and can be configured as power-down or standby.

¹ See the Theory of Operation section and the Applications Information section for more information on isolating the planes for optimal performance.

² Denotes clock domain.

³ Denotes SYSREF± domain.

⁴ Denotes isolation domain.

TYPICAL PERFORMANCE CHARACTERISTICS

2.0 GSPS

AVDD1 = 0.975 V, AVDD1_SR = 0.975 V, AVDD2 = 1.9 V, AVDD3 = 2.5 V, DVDD = 0.975 V, DRVDD1 = 0.975 V, DRVDD2 = 1.9 V, SPIVDD = 1.9 V, sampling rate = 2.0 GHz, clock divider = 2, 1.7 V p-p full-scale differential input, input amplitude (A_{IN}) = -2.0 dBFS, $T_j = 70^\circ\text{C}$ ($T_A = 25^\circ\text{C}$), 128k fast Fourier transform (FFT) sample, unless otherwise noted. See Table 10 for the recommended settings.

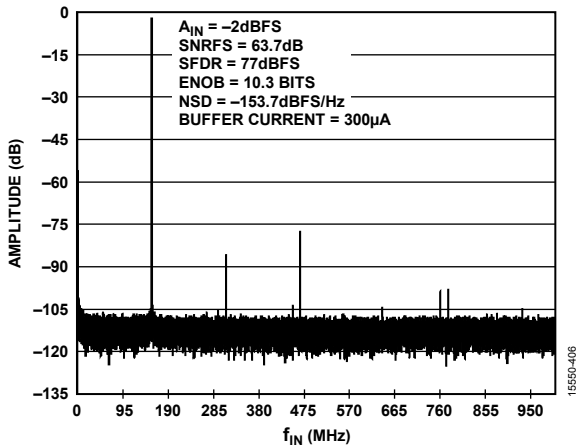

Figure 6. Single-Tone FFT at $f_{IN} = 155$ MHz

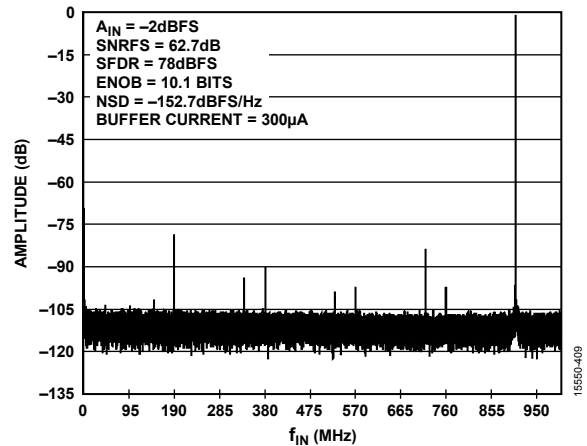

Figure 9. Single-Tone FFT at $f_{IN} = 905$ MHz

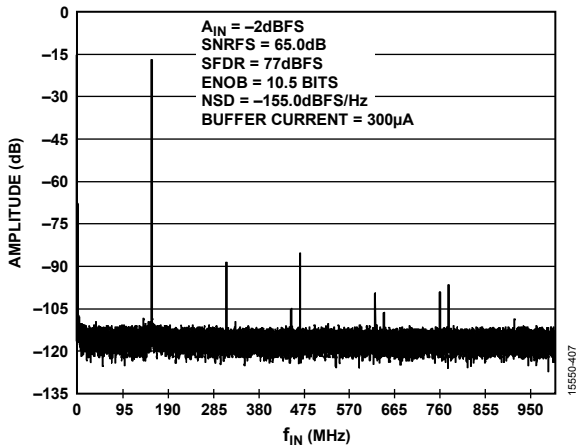

Figure 7. Single-Tone FFT at $f_{IN} = 155$ MHz, Full-Scale Voltage = 2.04 V p-p

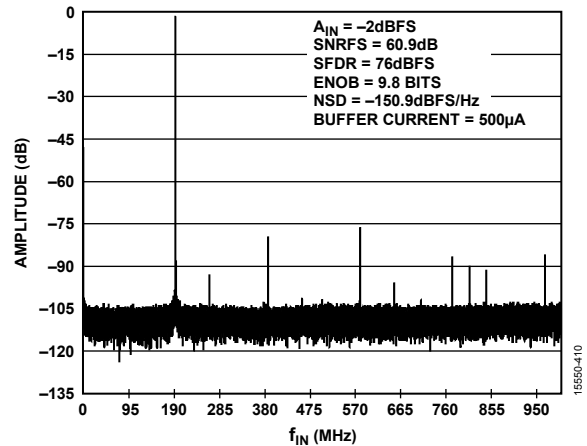

Figure 10. Single-Tone FFT at $f_{IN} = 1807$ MHz

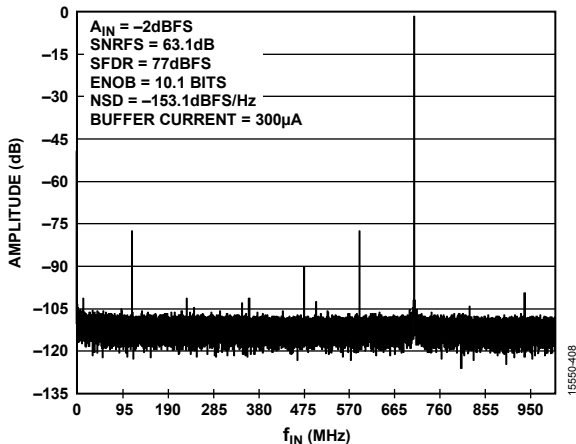

Figure 8. Single-Tone FFT at $f_{IN} = 750$ MHz

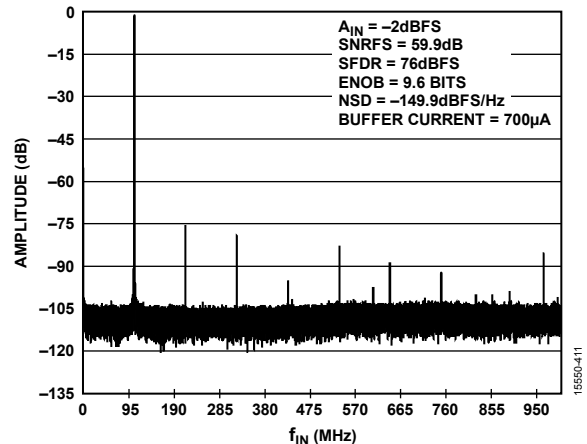

Figure 11. Single-Tone FFT at $f_{IN} = 2100$ MHz

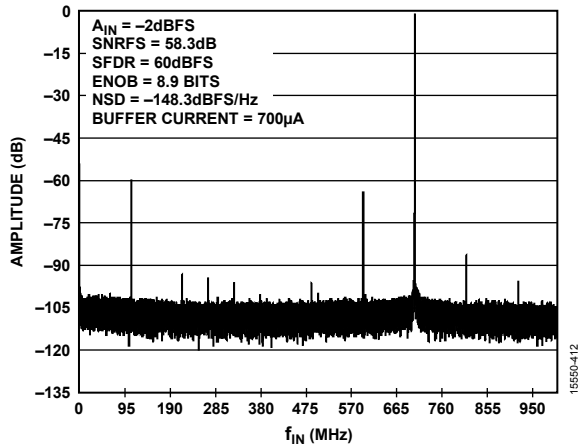

Figure 12. Single-Tone FFT at $f_{IN} = 3300 \text{ MHz}$

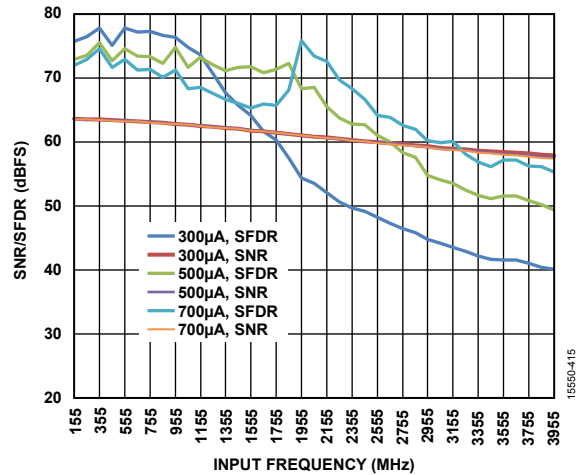

Figure 15. SNR/SFDR vs. Input Frequency (f_{IN}) for Various Buffer Currents

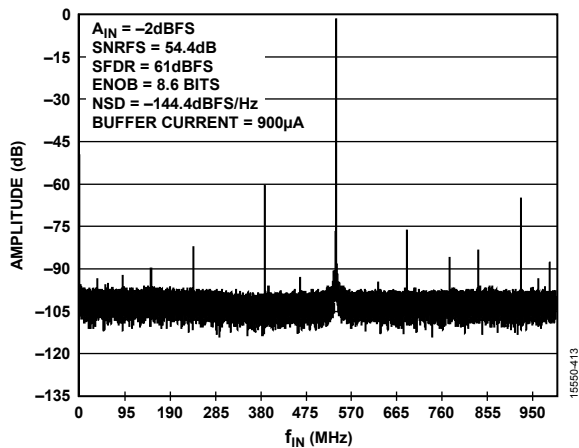

Figure 13. Single-Tone FFT at $f_{IN} = 4350 \text{ MHz}$; Full-Scale Voltage = 1.1 V_{p-p}

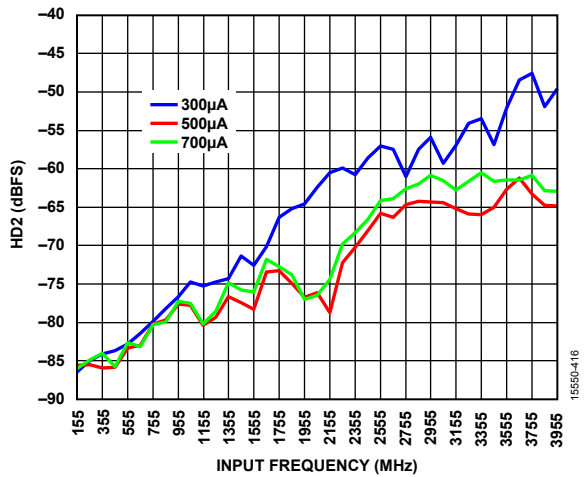

Figure 16. HD2 vs. Input Frequency (f_{IN}) for Various Buffer Currents

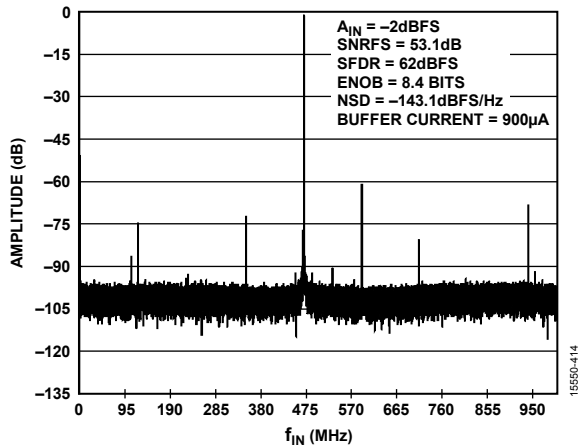

Figure 14. Single-Tone FFT at $f_{IN} = 5400 \text{ MHz}$; Full-Scale Voltage = 1.1 V_{p-p}

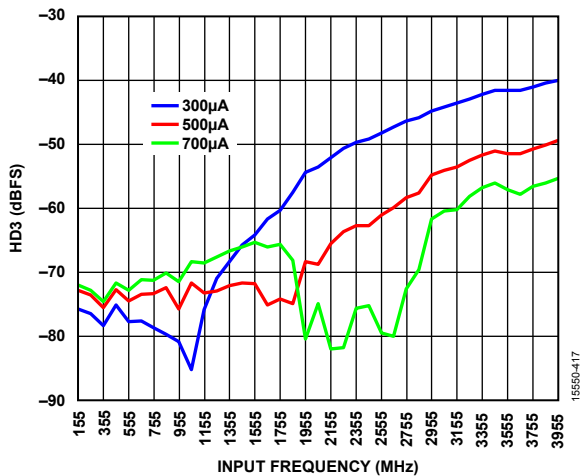

Figure 17. HD3 vs. Input Frequency (f_{IN}) for Various Buffer Currents

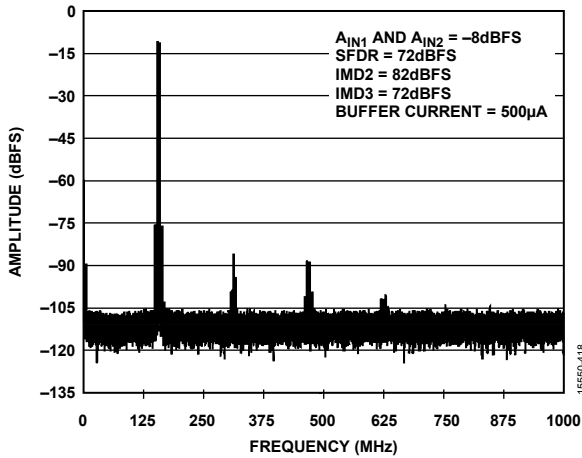

Figure 18. Two-Tone FFT; $f_{IN1} = 1841$ MHz, $f_{IN2} = 1846$ MHz; A_{IN1} and $A_{IN2} = -8$ dBFS

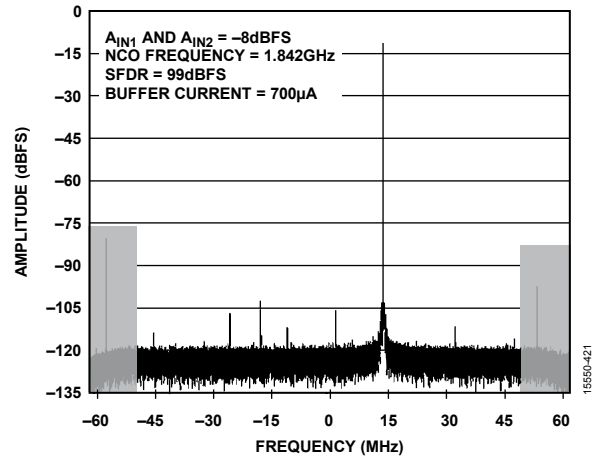

Figure 21. Two-Tone FFT; $f_{IN1} = 947.5$ MHz, $f_{IN2} = 1855.5$ MHz $f_{CLK} = 1.96608$ GHz; Decimation Ratio = 16, NCO Frequency = 1842.5 MHz

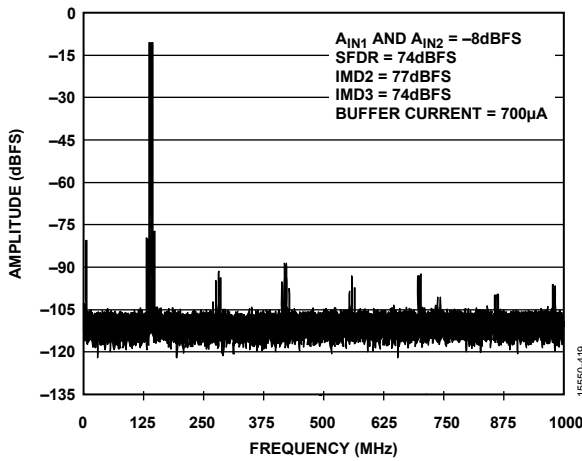

Figure 19. Two-Tone FFT; $f_{IN1} = 2137$ MHz, $f_{IN2} = 2142$ MHz; A_{IN1} and $A_{IN2} = -8$ dBFS

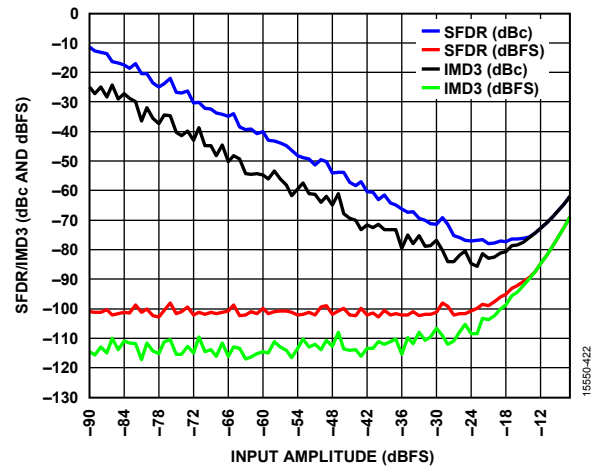

Figure 22. Two-Tone SFDR/IMD3 vs. Input Amplitude (A_{IN}) with $f_{IN1} = 1841.5$ MHz, $f_{IN2} = 1846.5$ MHz

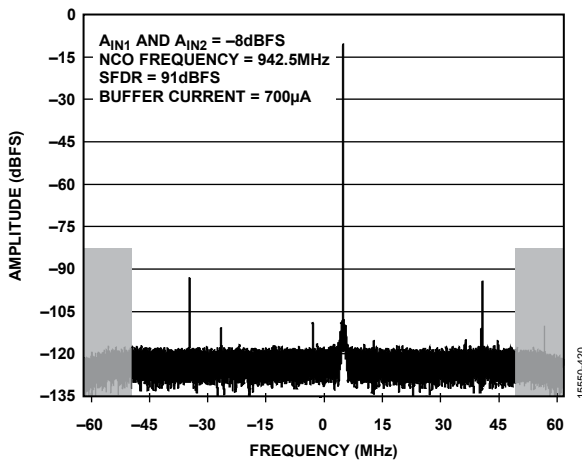

Figure 20. Two-Tone FFT; $f_{IN1} = 947.5$ MHz, $f_{IN2} = 1855.5$ MHz $f_{CLK} = 1.96608$ GHz; Decimation Ratio = 16, NCO Frequency = 942.5 MHz

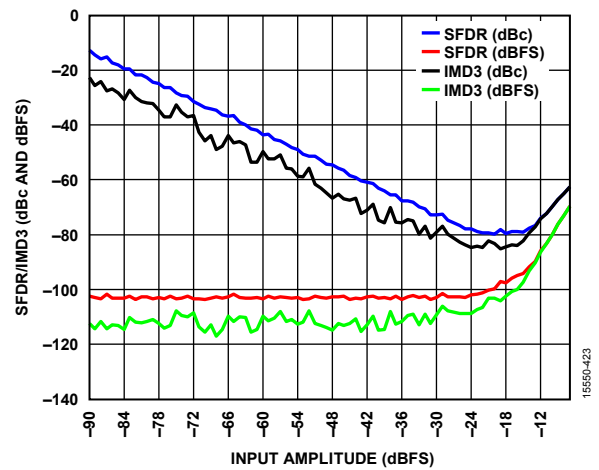

Figure 23. Two-Tone SFDR/IMD3 vs. Input Amplitude (A_{IN}) with $f_{IN1} = 2137.5$ MHz, $f_{IN2} = 2142.5$ MHz

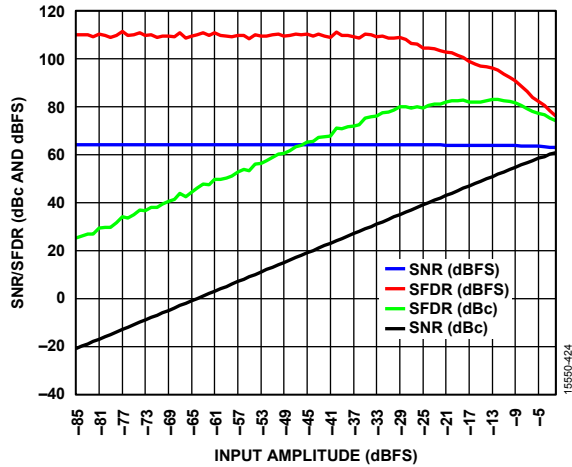

Figure 24. SNR/SFDR vs. Input Amplitude (A_{IN}), $f_{IN} = 900$ MHz

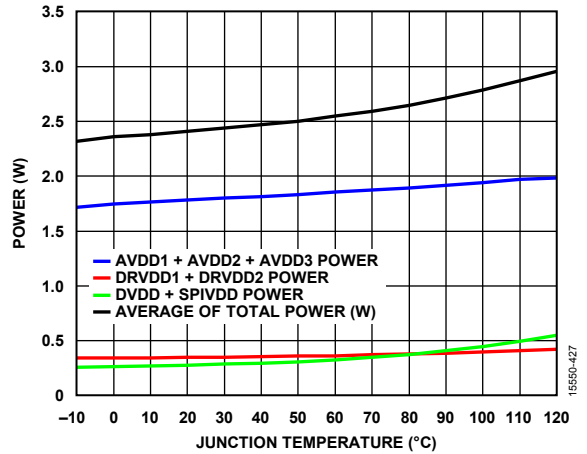

Figure 27. Power vs. Junction Temperature (T_J), $f_{IN} = 900$ MHz

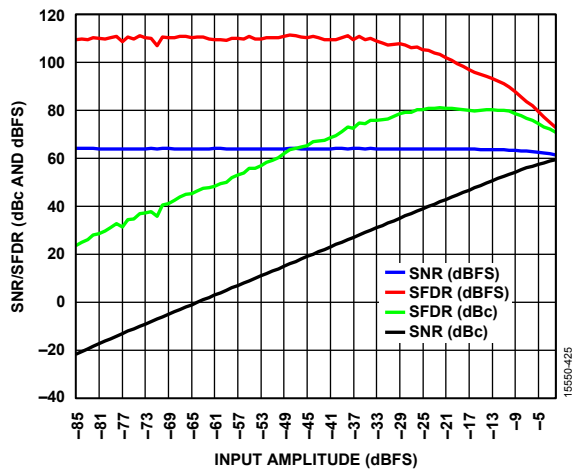

Figure 25. SNR/SFDR vs. Input Amplitude (A_{IN}), $f_{IN} = 1800$ MHz

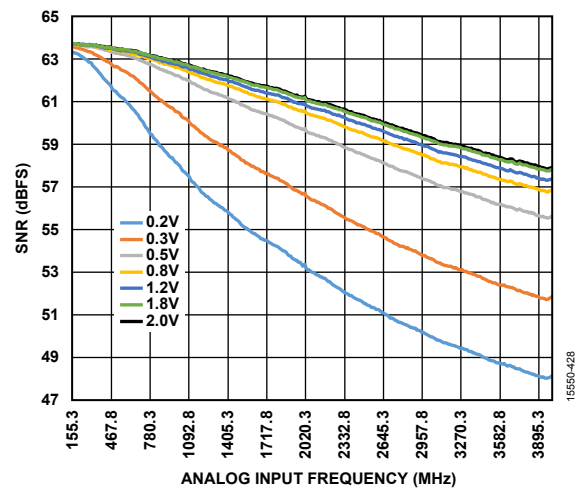

Figure 28. SNR vs. Analog Input Frequency (f_{IN}) for Various Clock Amplitude in Differential Peak-to-Peak Voltages

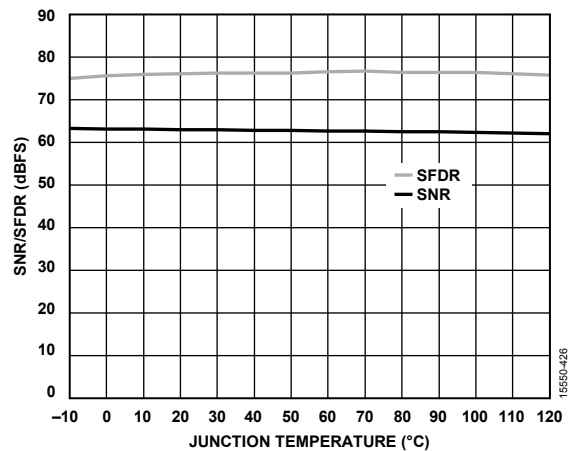

Figure 26. SNR/SFDR vs. Junction Temperature (T_J), $f_{IN} = 900$ MHz

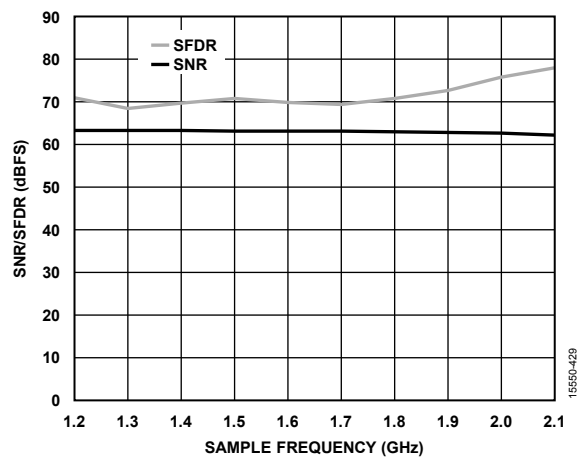

Figure 29. SNR/SFDR vs. Sample Frequency (f_s), $f_{IN} = 900$ MHz

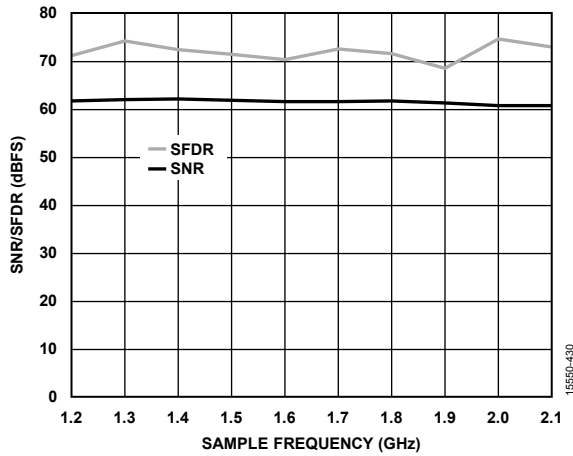

Figure 30. SNR/SFDR vs. Sample Frequency (f_s), $f_{IN} = 1.8$ GHz

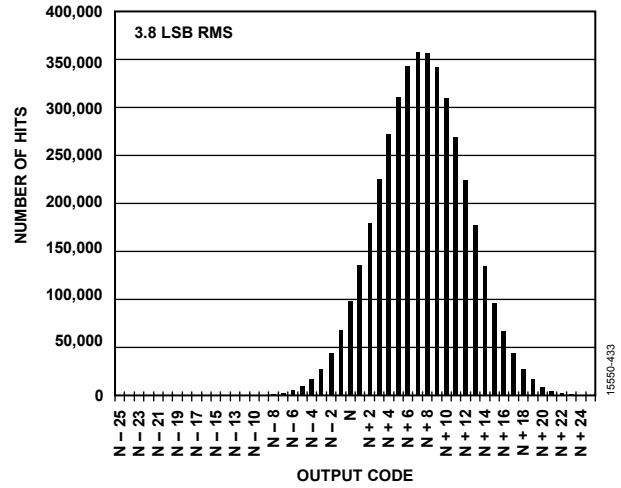

Figure 33. Input Referred Noise Histogram

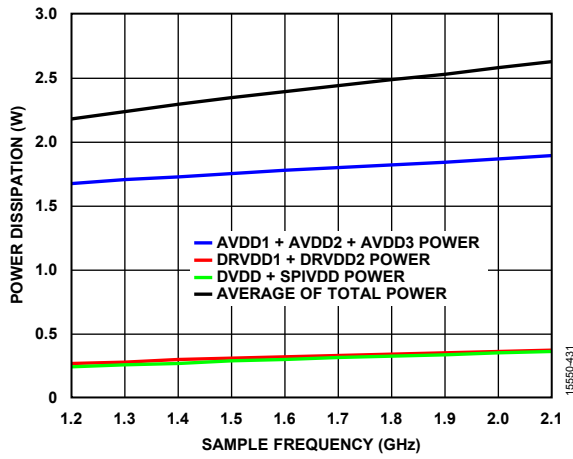

Figure 31. Power Dissipation vs. Sample Frequency (f_s), $f_{IN} = 1.8$ GHz

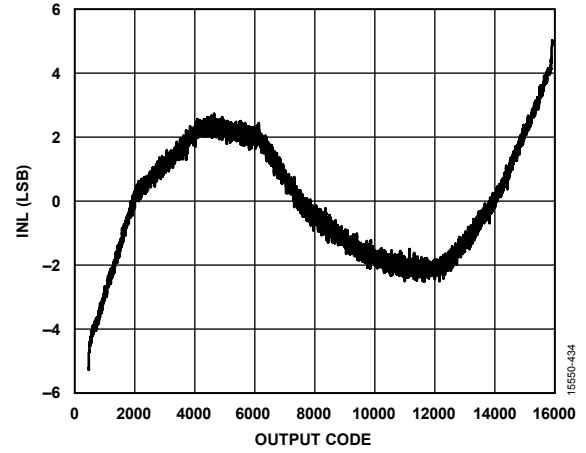

Figure 34. INL, $f_{IN} = 155$ MHz

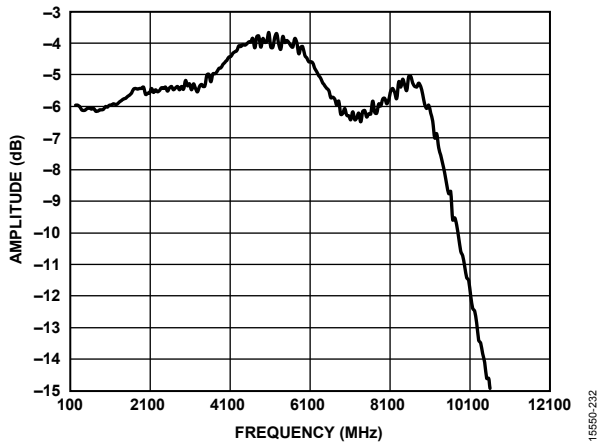

Figure 32. Input Bandwidth (See Figure 80 for the Input Configuration)

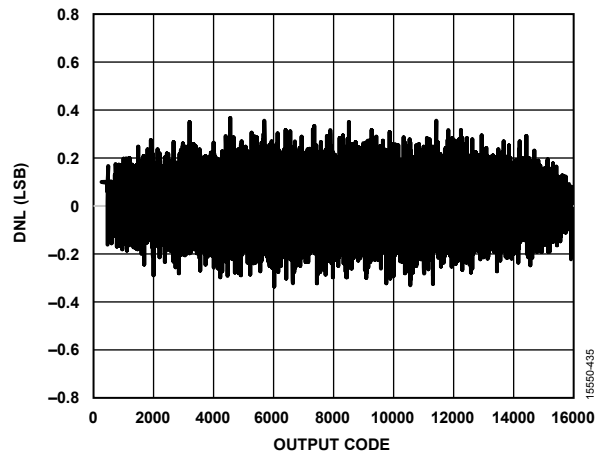

Figure 35. DNL, $f_{IN} = 155$ MHz

2.6 GSPS

AVDD1 = 0.975 V, AVDD1_SR = 0.975 V, AVDD2 = 1.9 V, AVDD3 = 2.5 V, DVDD = 0.975 V, DRVDD1 = 0.975 V, DRVDD2 = 1.9 V, SPIVDD = 1.9 V, sampling rate = 2.56 GHz, clock divider = 2, 1.7 V p-p full-scale differential input, input amplitude (A_{IN}) = -2.0 dBFS, $T_j = 70^\circ\text{C}$ ($T_A = 25^\circ\text{C}$), 128 k FFT sample, unless otherwise noted. See Table 10 for the recommended settings.

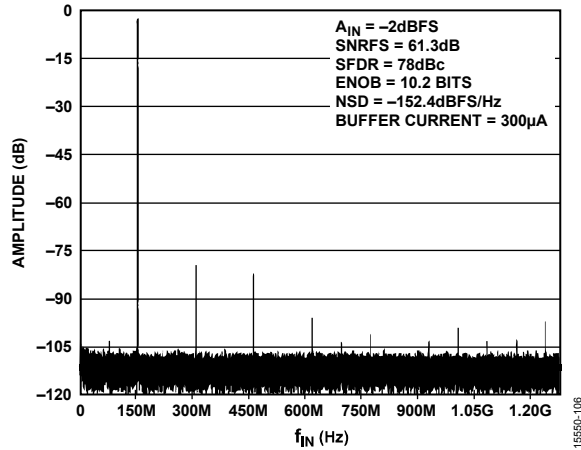

Figure 36. Single-Tone FFT at $f_{IN} = 155$ MHz

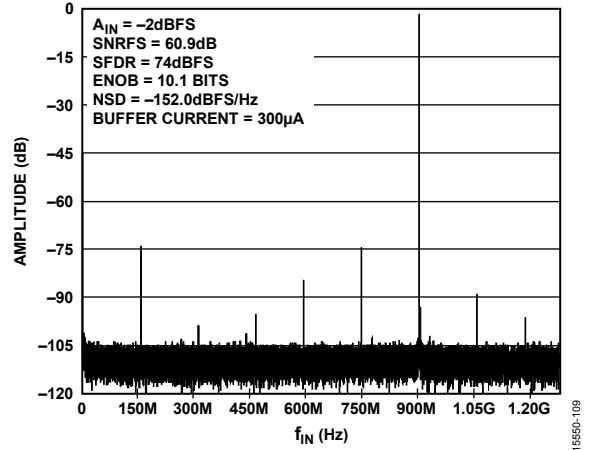

Figure 39. Single-Tone FFT at $f_{IN} = 905$ MHz

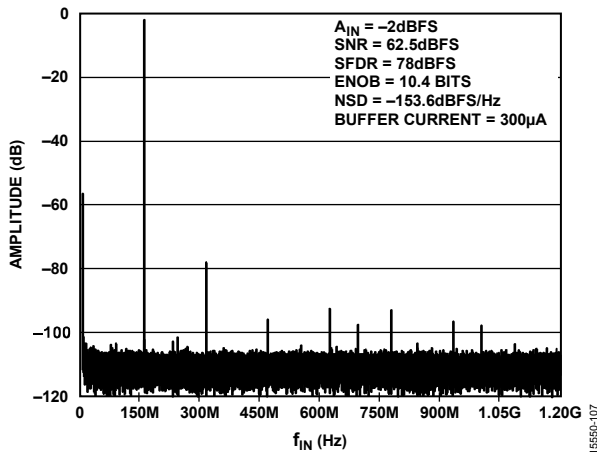

Figure 37. Single-Tone FFT at $f_{IN} = 155$ MHz, Full-Scale Voltage = 2.04 V p-p

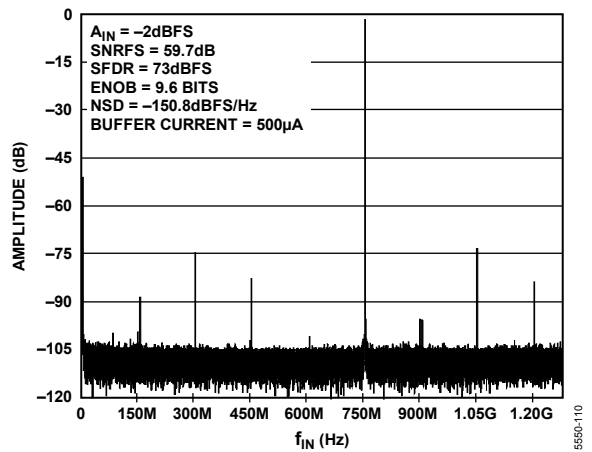

Figure 40. Single-Tone FFT at $f_{IN} = 1807$ MHz

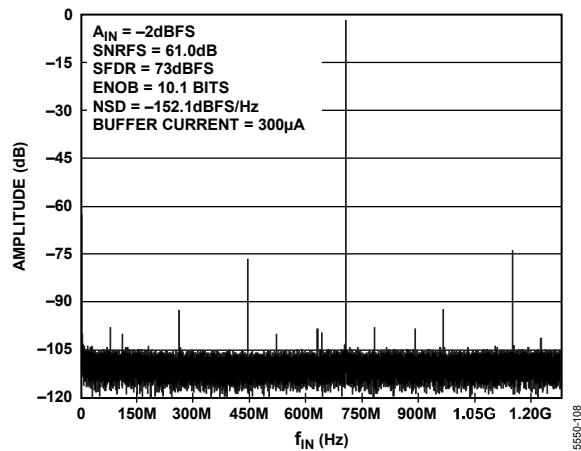

Figure 38. Single-Tone FFT at $f_{IN} = 750$ MHz

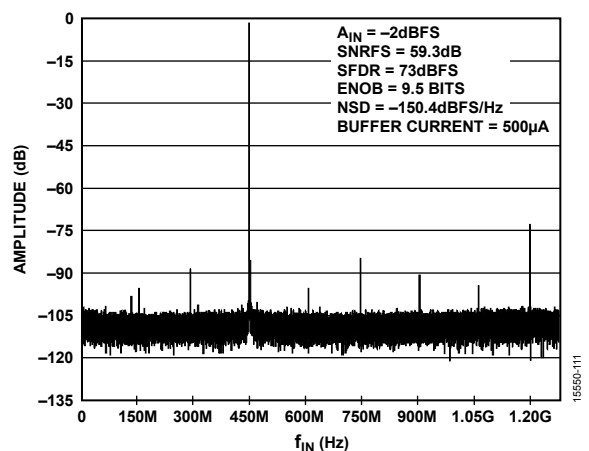

Figure 41. Single-Tone FFT at $f_{IN} = 2100$ MHz

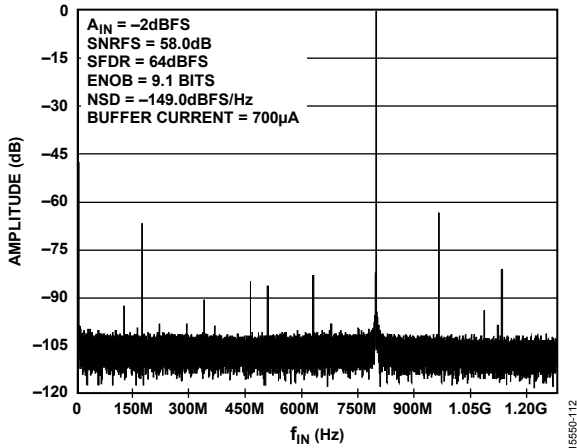

Figure 42. Single-Tone FFT at $f_{IN} = 3300$ MHz

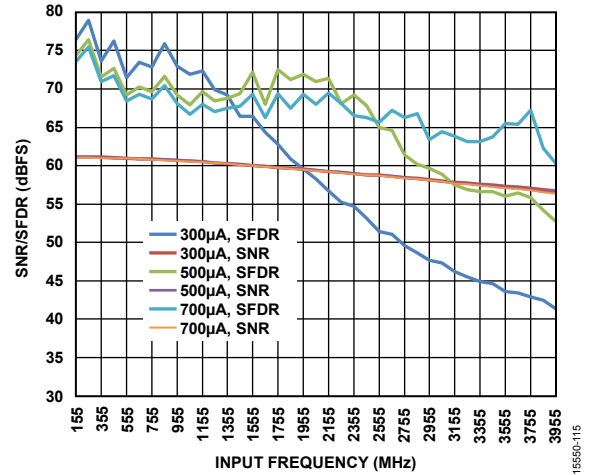

Figure 45. SNR/SFDR vs. Input Frequency (f_{IN}) for Various Buffer Currents

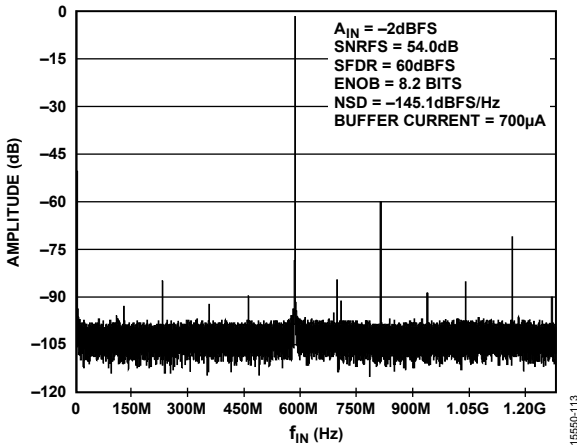

Figure 43. Single-Tone FFT at $f_{IN} = 4350$ MHz; Full-Scale Voltage = 1.1 V p-p

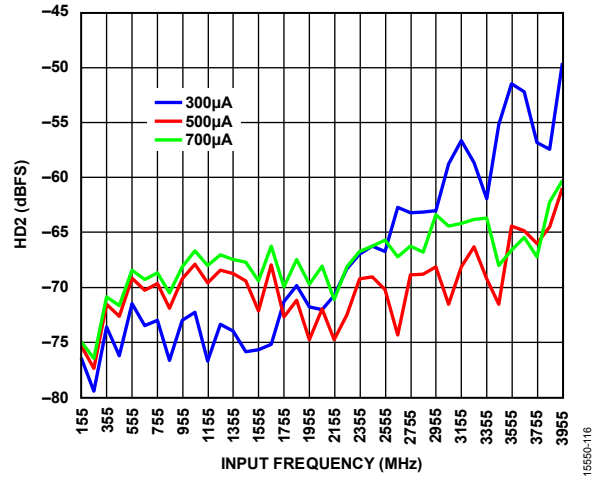

Figure 46. Second Harmonics (HD_2) vs. Input Frequency (f_{IN}) for Various Buffer Currents

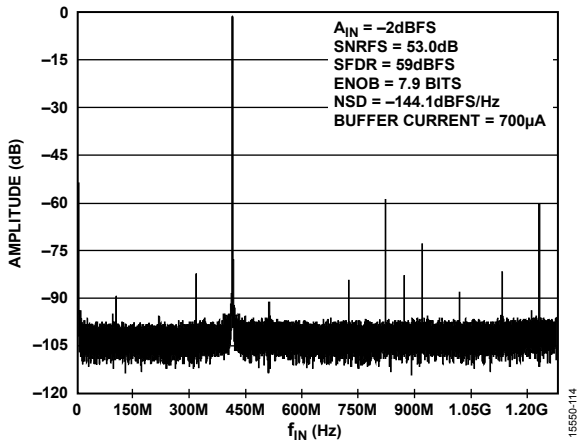

Figure 44. Single-Tone FFT at $f_{IN} = 5400$ MHz; Full-Scale Voltage = 1.1 V p-p

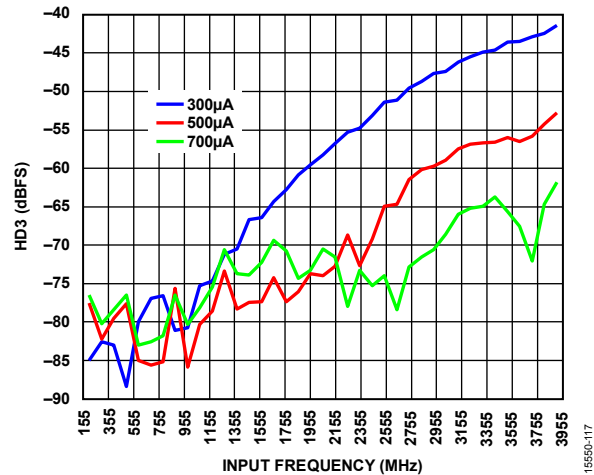

Figure 47. Third Harmonics (HD_3) vs. Input Frequency (f_{IN}) for Various Buffer Currents

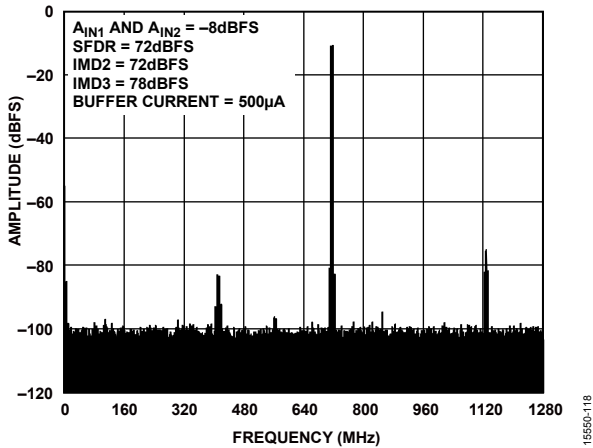

Figure 48. Two-Tone FFT; $f_{IN1} = 1841$ MHz, $f_{IN2} = 1846$ MHz; A_{IN1} and $A_{IN2} = -8$ dBFS

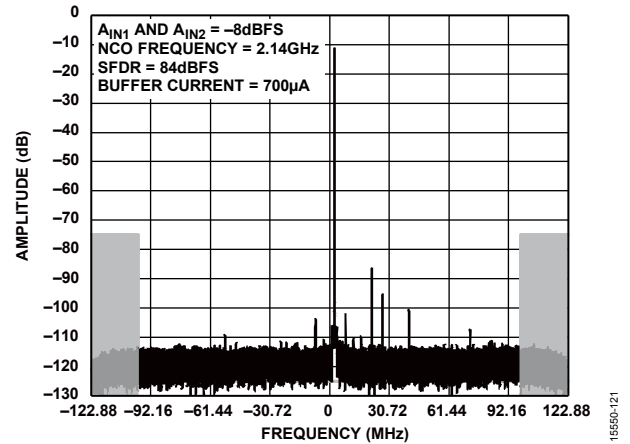

Figure 51. Two-Tone FFT; $f_{IN1} = 1846.5$ MHz, $f_{IN2} = 2142.5$ MHz $f_{CLK} = 2.4576$ GHz; Decimation Ratio = 10, NCO Frequency = 2140 MHz

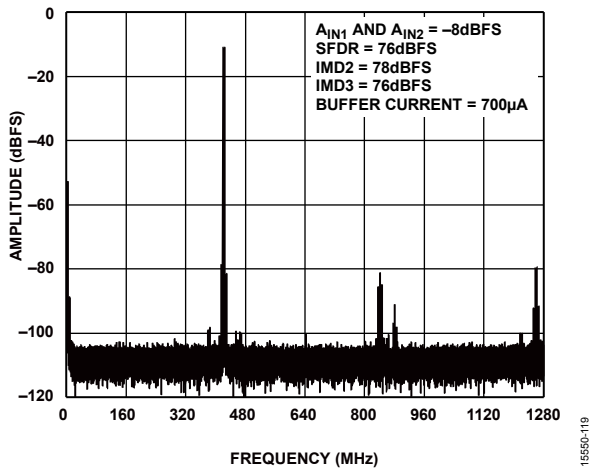

Figure 49. Two-Tone FFT; $f_{IN1} = 2137$ MHz, $f_{IN2} = 2142$ MHz; A_{IN1} and $A_{IN2} = -8$ dBFS

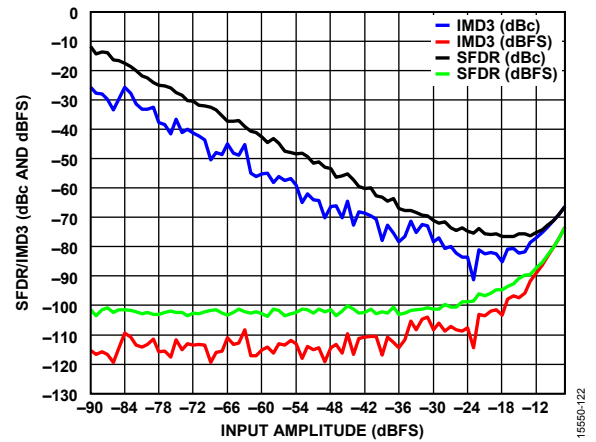

Figure 52. Two-Tone SFDR/IMD3 vs. Input Amplitude (A_{IN}) with $f_{IN1} = 1841.5$ MHz, $f_{IN2} = 1846.5$ MHz

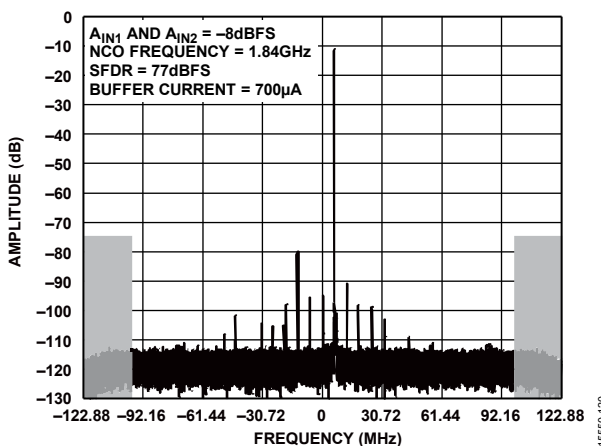

Figure 50. Two-Tone FFT; $f_{IN1} = 1846.5$ MHz, $f_{IN2} = 2142.5$ MHz $f_{CLK} = 2.4576$ GHz; Decimation Ratio = 10, NCO Frequency = 1840 MHz

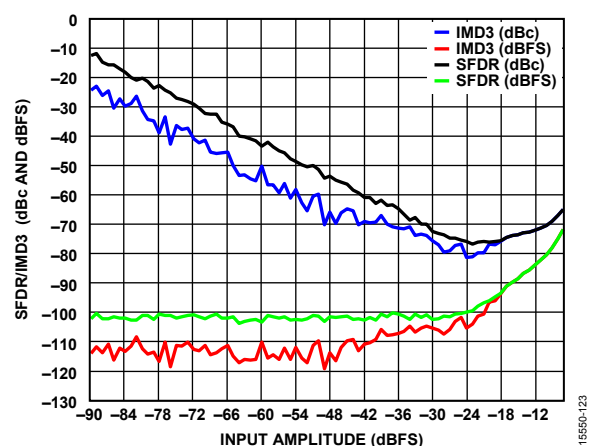

Figure 53. Two-Tone SFDR/IMD3 vs. Input Amplitude (A_{IN}) with $f_{IN1} = 2137.5$ MHz, $f_{IN2} = 2142.5$ MHz

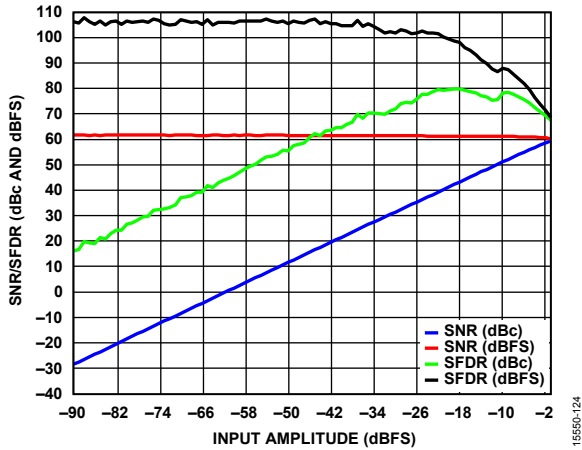

Figure 54. SNR/SFDR vs. Input Amplitude (A_{IN}), $f_{IN} = 900$ MHz

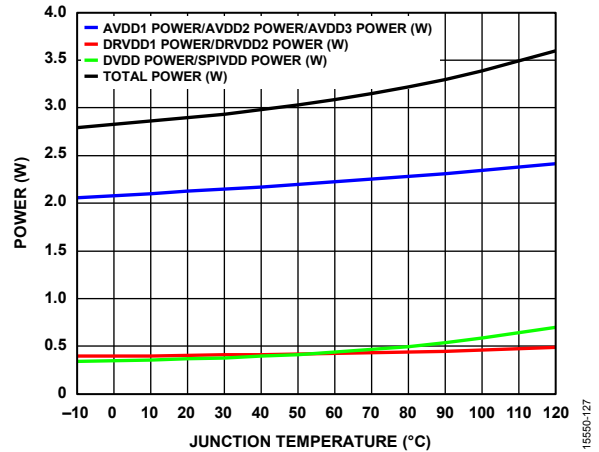

Figure 57. Power vs. Junction Temperature (T_J), $f_{IN} = 900$ MHz

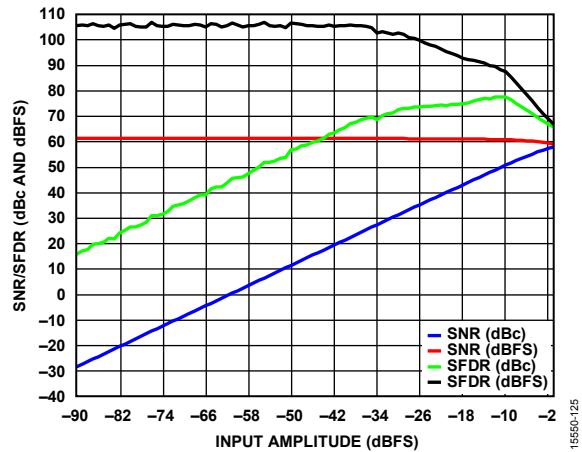

Figure 55. SNR/SFDR vs. Input Amplitude (A_{IN}), $f_{IN} = 1800$ MHz

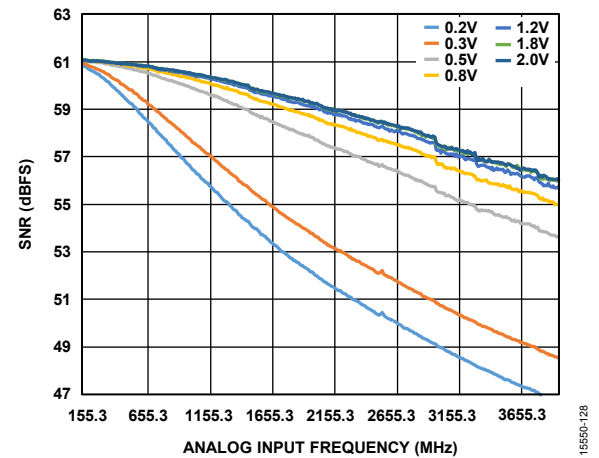

Figure 58. SNR vs. Analog Input Frequency (f_{IN}) for Various Clock Amplitude in Differential Peak-to-Peak Voltages

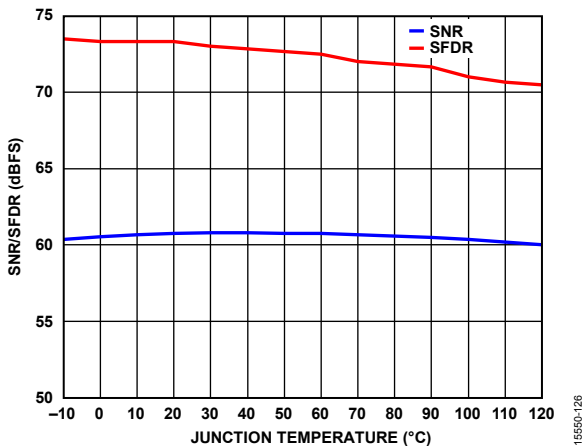

Figure 56. SNR/SFDR vs. Junction Temperature (T_J), $f_{IN} = 900$ MHz

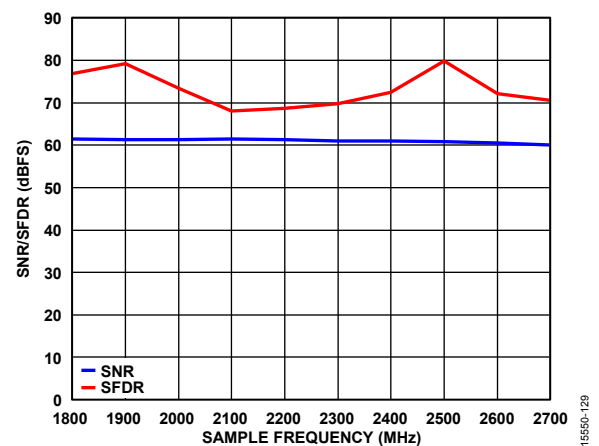

Figure 59. SNR/SFDR vs. Sample Frequency (f_s), $f_{IN} = 900$ MHz

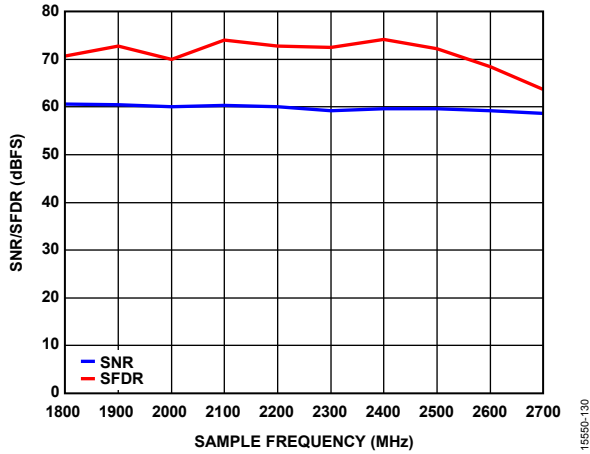

Figure 60. SNR/SFDR vs. Sample Frequency (f_s), $f_{IN} = 1.8$ GHz

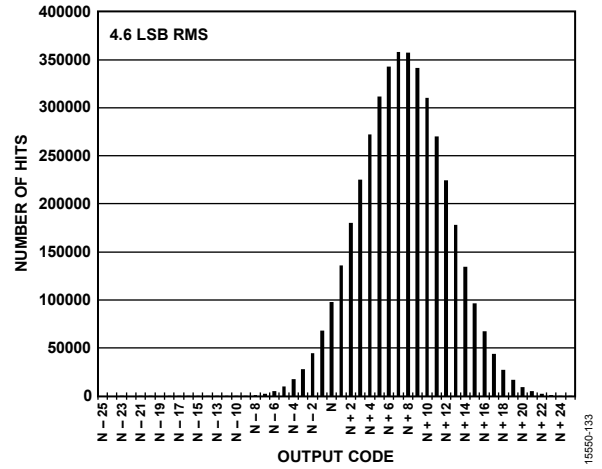

Figure 63. Input Referred Noise Histogram

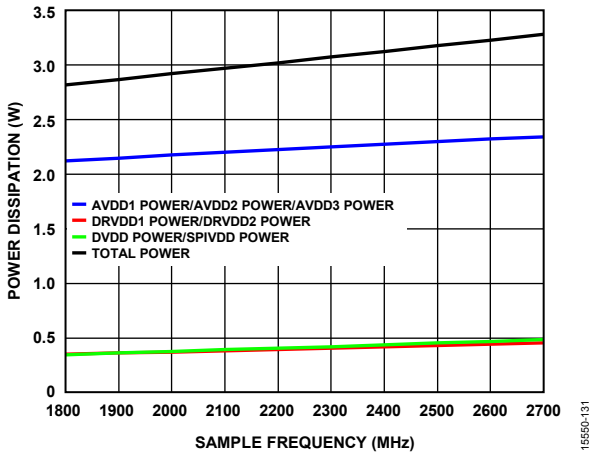

Figure 61. Power Dissipation vs. Sample Frequency (f_s), $f_{IN} = 1.8$ GHz

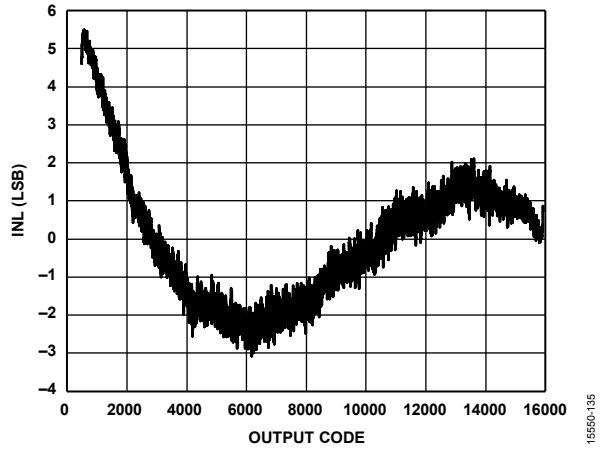

Figure 64. INL, $f_{IN} = 155$ MHz

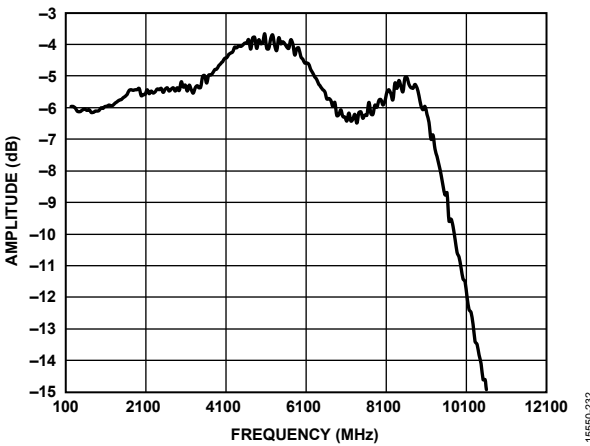

Figure 62. Input Bandwidth (See Figure 80 for the Input Configuration)

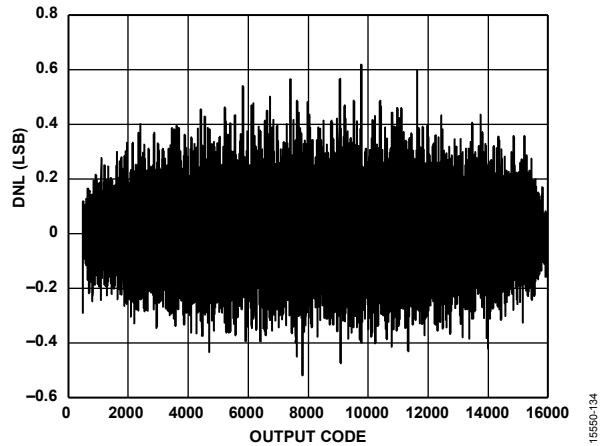

Figure 65. DNL, $f_{IN} = 155$ MHz

EQUIVALENT CIRCUITS

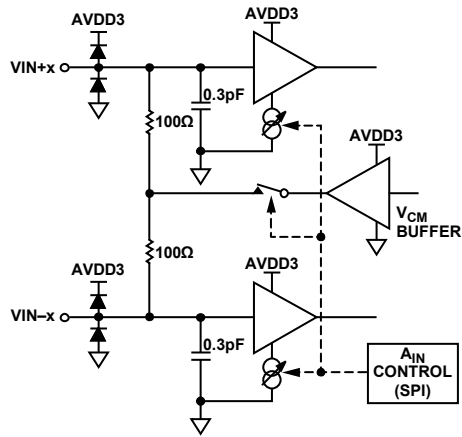

Figure 66. Analog Inputs

15550-037

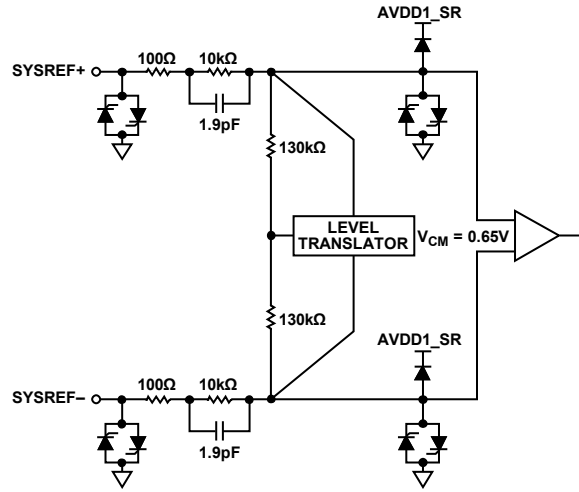

Figure 69. SYSREF± Inputs

15550-039

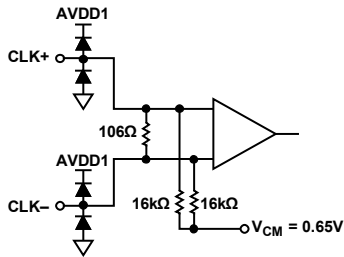

Figure 67. Clock Inputs

15550-038

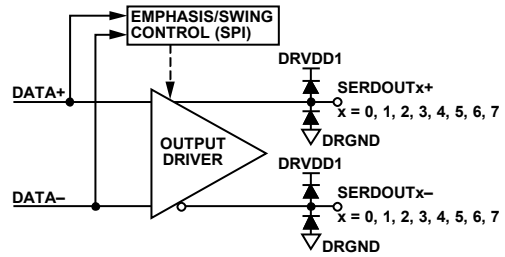

Figure 70. Digital Outputs

15550-040

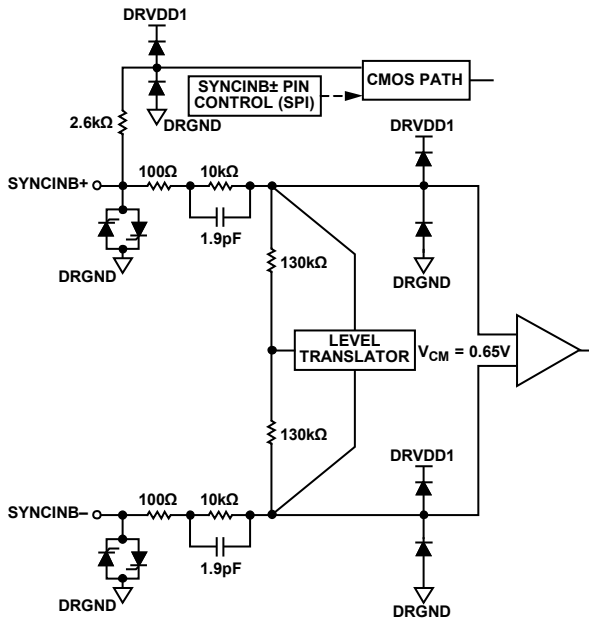

Figure 68. SYNCINB± Inputs

15550-041

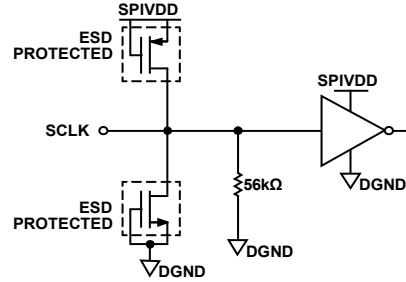

Figure 71. SCLK Input

15550-042

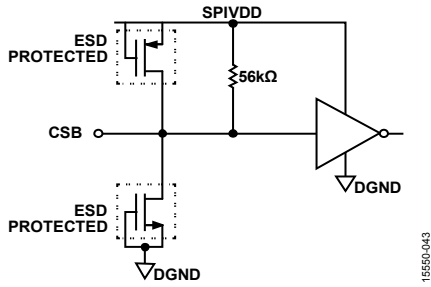

Figure 72. CSB Input

15550-043

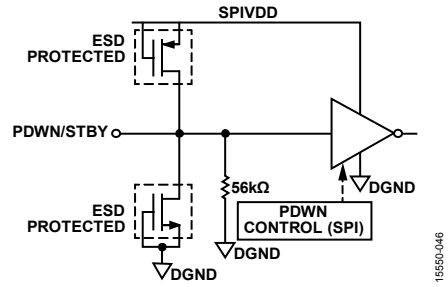

Figure 74. PDWN/STBY Input

15550-046

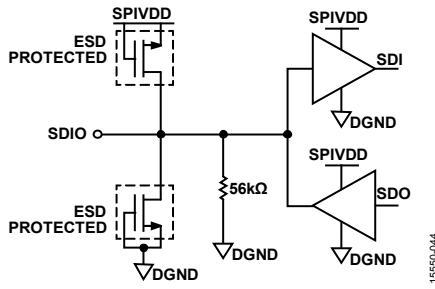

Figure 73. SDIO Input

15550-044

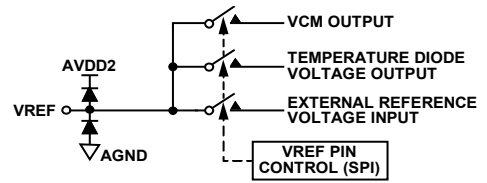

Figure 75. VREF Input/Output

15550-047

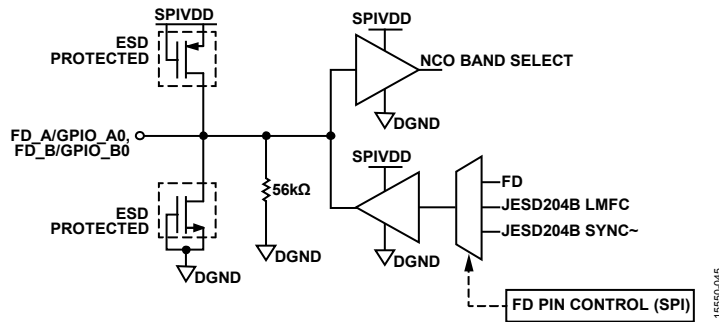

Figure 76. FD_A/GPIO_A0, FD_B/GPIO_B0

15550-045

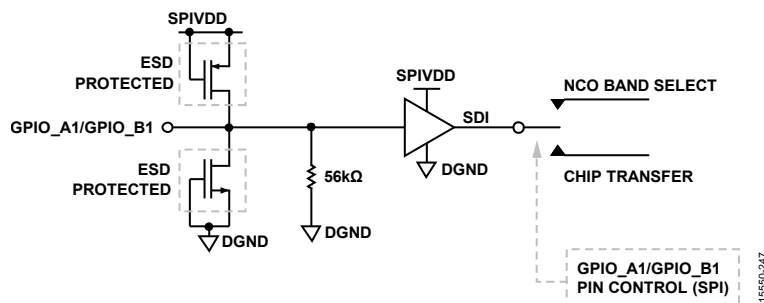

Figure 77. GPIO_A1/GPIO_B1

15550-247

THEORY OF OPERATION

The AD9689 has two analog input channels and up to eight JESD204B output lane pairs. The ADC samples wide bandwidth analog signals of up to 5 GHz. The actual -3 dB roll-off of the analog inputs is 9 GHz. The AD9689 is optimized for wide input bandwidth, high sampling rate, excellent linearity, and low power in a small package.

The dual ADC cores feature a multistage, differential pipelined architecture with integrated output error correction logic. Each ADC features wide bandwidth inputs supporting a variety of user-selectable input ranges. An integrated voltage reference eases design considerations.

The AD9689 has several functions that simplify the AGC function in a communications receiver. The programmable threshold detector allows monitoring of the incoming signal power using the fast detect output bits of the ADC. If the input signal level exceeds the programmable threshold, the fast detect indicator goes high. Because this threshold indicator has low latency, the user can quickly turn down the system gain to avoid an overrange condition at the ADC input.

The Subclass 1 JESD204B-based high speed serialized output data lanes can be configured in one-lane ($L = 1$), two-lane ($L = 2$), four-lane ($L = 4$), and eight-lane ($L = 8$) configurations, depending on the sample rate and the decimation ratio. Multiple device synchronization is supported through the $\text{SYSREF}\pm$ and $\text{SYNCINB}\pm$ input pins. The $\text{SYSREF}\pm$ pin in the AD9689 can also be used as a timestamp of data as it passes through the ADC and out of the JESD204B interface.

ADC ARCHITECTURE

The architecture of the AD9689 consists of an input buffered pipelined ADC. The input buffer provides a termination impedance to the analog input signal. This termination impedance is set to $200\ \Omega$. The equivalent circuit diagram of the analog input termination is shown in Figure 66. The input buffer is optimized for high linearity, low noise, and low power across a wide bandwidth.

The input buffer provides a linear high input impedance (for ease of drive) and reduces kickback from the ADC. The quantized outputs from each stage are combined into a final 14-bit result in the digital correction logic. The pipelined architecture permits the first stage to operate with a new input sample; at the same time, the remaining stages operate with the preceding samples. Sampling occurs on the rising edge of the clock.

ANALOG INPUT CONSIDERATIONS

The analog input to the AD9689 is a differential buffer. The internal common-mode voltage of the buffer is 1.4 V. The clock signal alternately switches the input circuit between sample mode and hold mode.

Either a differential capacitor or two single-ended capacitors (or a combination of both) can be placed on the inputs to provide a matching passive network. These capacitors ultimately create a low-pass filter that limits unwanted broadband noise. For more information, refer to the *Analog Dialogue* article, “[Transformer-Coupled Front-End for Wideband A/D Converters](#)” (Volume 39, April 2005). In general, the precise front-end network component values depend on the application.

Figure 78 shows the differential input return loss curve for the analog inputs across a frequency range of 100 MHz to 10 GHz. The reference impedance is $100\ \Omega$.

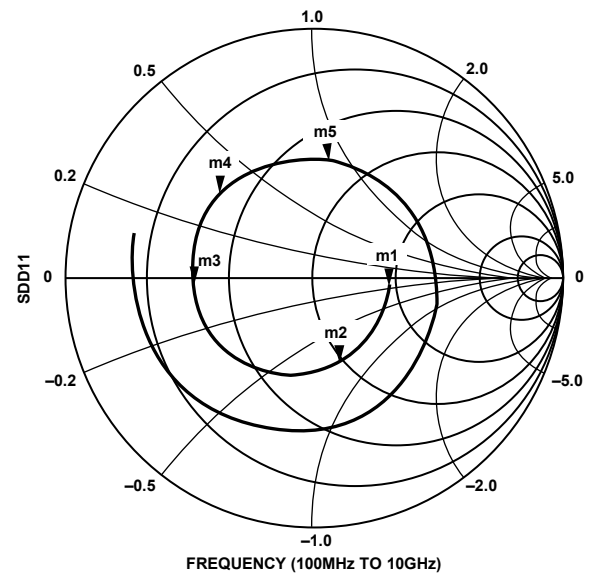

m1 FREQUENCY = 100MHz SDD11 = 0.301/-8.069 IMPEDANCE = $Z_0 \times (1.838 - j0.171)$	m4 FREQUENCY = 4GHz SDD11 = 0.500/136.667 IMPEDANCE = $Z_0 \times (0.379 + j0.347)$
m2 FREQUENCY = 1GHz SDD11 = 0.352/-73.534 IMPEDANCE = $Z_0 \times (0.947 - j0.731)$	m5 FREQUENCY = 5GHz SDD11 = 0.475/79.360 IMPEDANCE = $Z_0 \times (0.737 + j0.889)$
m3 FREQUENCY = 3GHz SDD11 = 0.496/175.045 IMPEDANCE = $Z_0 \times (0.337 - j0.038)$	

Figure 78. Differential Input Return Loss

For best dynamic performance, the source impedances driving $\text{VIN}+x$ and $\text{VIN}-x$ must be matched such that common-mode settling errors are symmetrical. These errors are reduced by the common-mode rejection of the ADC. An internal reference buffer creates a differential reference that defines the span of the ADC core.

Maximum SNR performance is achieved by setting the ADC to the largest span in a differential configuration. For the AD9689, the available span is programmable through the SPI port from 1.13 V p-p to 2.04 V p-p differential, with 1.7 V p-p differential being the default.

Differential Input Configurations

There are several ways to drive the AD9689, either actively or passively. Optimum performance is achieved by driving the analog input differentially.

For applications where SNR and SFDR are key parameters, differential transformer coupling is the recommended input configuration (see Figure 79 and Table 9) because the noise performance of most amplifiers is not adequate to achieve the true performance of the AD9689.

For low to midrange frequencies, a double balun or double transformer network (see Figure 79 and Table 9) is recommended for optimum performance of the AD9689.

For higher frequencies in the second or third Nyquist zones, it is recommended to remove some of the front-end passive components to ensure wideband operation (see Figure 80 and Table 9).

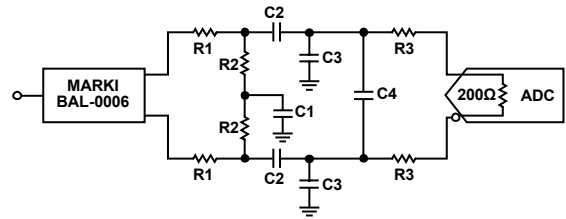

NOTES:
1. SEE TABLE 9 FOR COMPONENT VALUES

Figure 79. Differential Transformer Coupled Configuration for the AD9689

15550-249

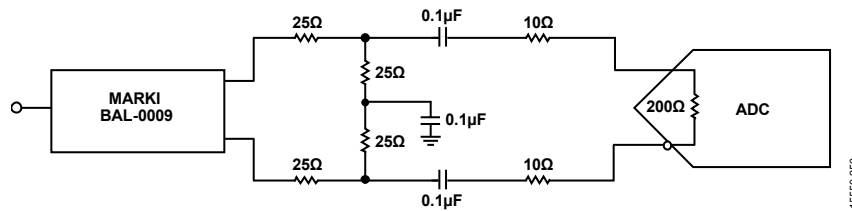

Figure 80. Input Network Configuration for Frequencies > 5 GHz

15550-250

Table 9. Differential Transformer Coupled Input Configuration Component Values

Frequency Range	Transformer	R1	R2	R3	C1	C2	C3	C4
<5000 MHz	BAL-0006	25 Ω	25 Ω	10 Ω	0.1 μF	0.1 μF	0.4 pF	0.4 pF or open
>5000 MHz	BAL-0009	25 Ω	25 Ω	10 Ω	0.1 μF	0.1 μF	Open	Open

Input Common Mode

The analog inputs of the AD9689 are internally biased to the common-mode voltage, as shown in Figure 82. The common-mode buffer has a limited range in that the performance suffers greatly if the common-mode voltage drops by more than 50 mV on either side of the nominal value.

For dc-coupled applications, the recommended operation procedure is to export the common-mode voltage to the VREF pin using the SPI writes listed in this section. The common-mode voltage must be set by the exported value to ensure proper ADC operation. Disconnect the internal common-mode buffer from the analog input using Register 0x1908.

When performing SPI writes for dc coupling operation, use the following register settings in order:

1. Set Register 0x1908, Bit 2 to disconnect the internal common-mode buffer from the analog input. Note that this is a local register.
2. Set Register 0x18A6 to 0x00 to turn off the voltage reference.
3. Set Register 0x18E6 to 0x00 to turn off the temperature diode export.
4. Set Register 0x18E3, Bit 6 to 1 to turn on the V_{CM} export.
5. Set Register 0x18E3, Bits[5:0] to the buffer current setting (Register 0x1A4C and Register 0x1A4D) to improve the accuracy of the common-mode export.

Figure 81 shows the block diagram of a dc-coupled application.

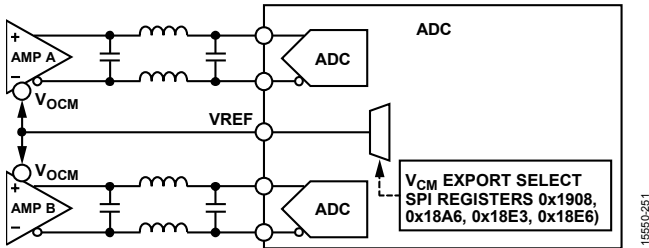

Figure 81. DC-Coupled Application Using the AD9689

Analog Input Buffer Controls and SFDR Optimization

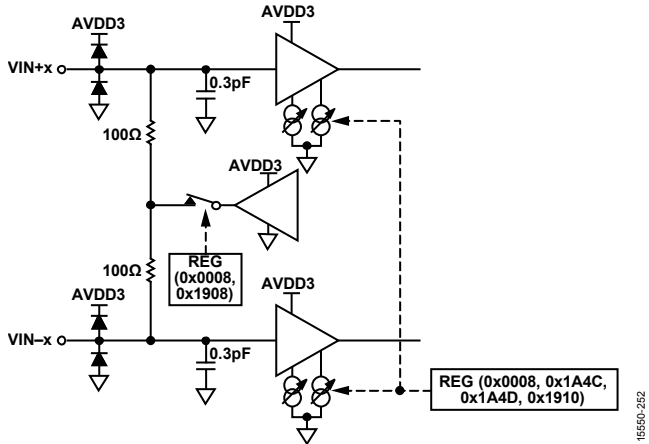

Figure 82. Analog Input Controls

The AD9689 input buffer offers flexible controls for the analog inputs, such as buffer current, dc coupling, and input full-scale adjustment. All the available controls are shown in Figure 82.

Using Register 0x1A4C and Register 0x1A4D, the buffer behavior on each channel can be adjusted to optimize the SFDR over various input frequencies and bandwidths of interest. Use Register 0x1910 to change the internal reference voltage. Changing the internal reference voltage results in a change in the input full-scale voltage.

When the input buffer current in Register 0x1A4C and Register 0x1A4D is set, the amount of current required by the AVDD3 supply changes. This relationship is shown in Figure 83. For a complete list of buffer current settings, see Table 46 and Table 53.

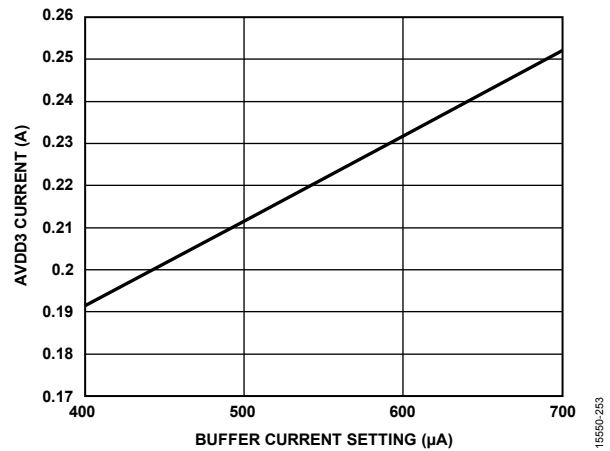

Figure 83. AVDD3 Current (I_{AVDD3}) vs. Buffer Current Setting (Buffer Control 1 Setting in Register 0x1A4C and Buffer Control 2 Setting in Register 0x1A4D)

Table 10 shows the recommended values for the buffer current for various Nyquist zones.

Table 10. SFDR Optimization for Input Frequencies

Product	Frequency	Register 0x1A4C and Register 0x1A4D	High Frequency Setting Register 0x1A48
AD9689-2600	DC to 1.3 GHz	Default (300 µA)	Default (0x14)
	1.3 GHz to 2.6 GHz	500 µA	Default (0x14)
	>2.6 GHz	700 µA	0x54
AD9689-2000	DC to 1000 MHz	Default (300 µA)	N/A ¹
	1 GHz to 2 GHz	500 µA	N/A
	>2 GHz	700 µA	N/A

¹ N/A means not applicable.

Dither

The AD9689 has internal on-chip dither circuitry that improves the ADC linearity and SFDR, particularly at smaller signal levels. A known but random amount of white noise is injected into the input of the AD9689. This dither improves the small signal linearity within the ADC transfer function and is precisely subtracted out digitally. The dither is turned on by default and does not reduce the ADC input dynamic range. The data sheet specifications and limits are obtained with the dither turned on. The dither is on by default. It is not recommended to turn it off.

Absolute Maximum Input Swing

The absolute maximum input swing allowed at the inputs of the AD9689 is 5.8 V p-p differential. Signals operating near or at this level can cause permanent damage to the ADC. See Table 6 for more information.

VOLTAGE REFERENCE

A stable and accurate 0.5 V voltage reference is built into the AD9689. This internal 0.5 V reference sets the full-scale input range of the ADC. The full-scale input range can be adjusted via the ADC input full-scale control register (Register 0x1910). For more information on adjusting the input swing, see Table 46 and Table 53. Figure 85 shows the block diagram of the internal 0.5 V reference controls.

The SPI Register 0x18A6 enables the user to either use this internal 0.5 V reference, or to provide an external 0.5 V reference. When using an external voltage reference, provide a 0.5 V reference. The full-scale adjustment is made using the SPI, irrespective of the reference voltage. For more information on adjusting the full-scale level of the AD9689, refer to the Memory Map section.

The SPI writes required to use the external voltage reference, in order, are as follows:

1. Set Register 0x18E3 to 0x00 to turn off the V_{CM} export.
2. Set Register 0x18E6 to 0x00 to turn off the temperature diode export.
3. Set Register 0x18A6 to 0x01 to turn on the external voltage reference.

The use of an external reference may be necessary, in some applications, to enhance the gain accuracy of the ADC or to improve thermal drift characteristics. Figure 84 shows the typical drift characteristics of the internal 0.5 V reference.

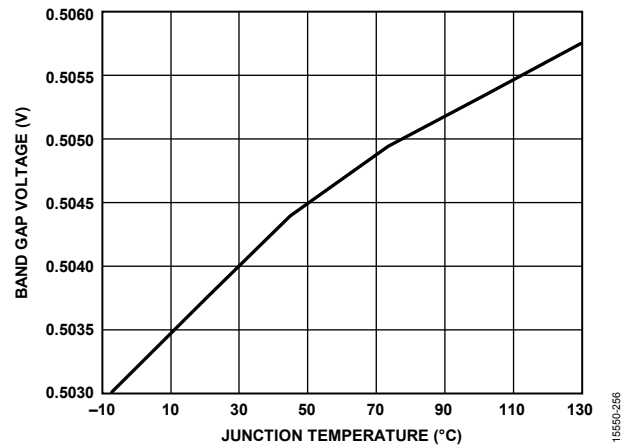

Figure 84. Typical Reference Voltage (V_{REF}) Drift

The external reference must be a stable 0.5 V reference. The [ADR130](#) is a sufficient option for providing the 0.5 V reference. Figure 86 shows how the [ADR130](#) can be used to provide the external 0.5 V reference to the AD9689. The dashed lines show unused blocks within the AD9689 while using the [ADR130](#) to provide the external reference.

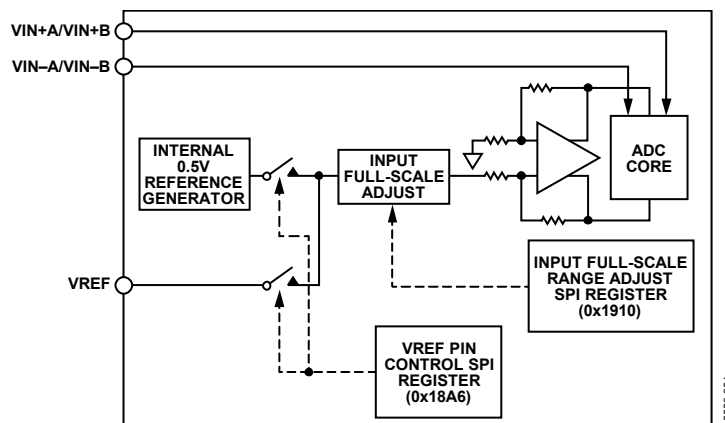

Figure 85. Internal Reference Configuration and Controls

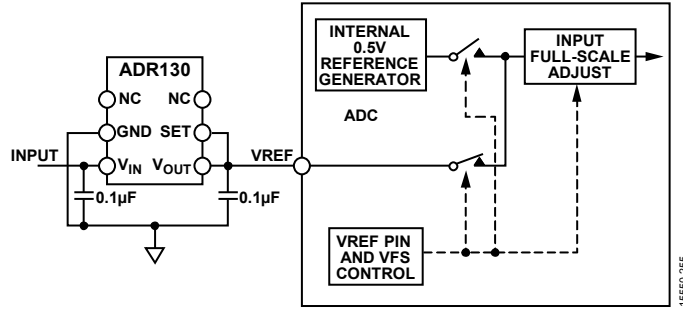

Figure 86. External Reference Using the ADR130

DC OFFSET CALIBRATION

The AD9689 contains a digital filter to remove the dc offset from the output of the ADC. For ac-coupled applications, this filter can be enabled by writing 0x86 to Register 0x0701. The filter computes the average dc signal and it is digitally subtracted from the ADC output. As a result, the dc offset is improved to better than 70 dBFS at the output. Because the filter does not distinguish between the source of dc signals, this feature can be used when the signal content at dc is not of interest. The filter corrects dc up to ±512 codes and saturates beyond this value.

CLOCK INPUT CONSIDERATIONS

For optimum performance, drive the AD9689 sample clock inputs (CLK+ and CLK-) with a differential signal. This signal is ac-coupled to the CLK+ and CLK- pins via a transformer or clock drivers. These pins are biased internally and require no additional biasing.

Figure 87 shows the differential input return loss curve for the clock inputs across a frequency range of 100 MHz to 6 GHz. The reference impedance is 100 Ω.

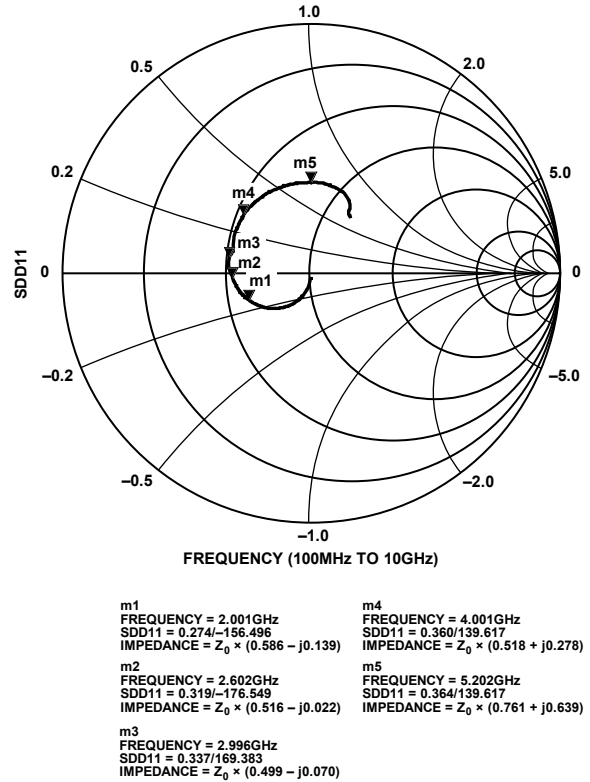

Figure 87. Differential Input Return Loss for the CLK± Inputs

Figure 88 shows a preferred method for clocking the AD9689. The low jitter clock source is converted from a single-ended signal to a differential signal using an RF transformer.

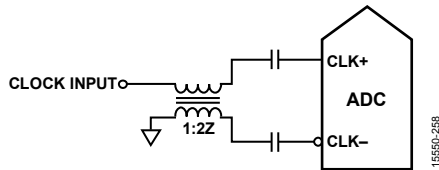

Figure 88. Transformer-Coupled Differential Clock

Another option is to ac couple a differential LVPECL or CML signal to the sample clock input pins, as shown in Figure 89 and Figure 90, respectively.

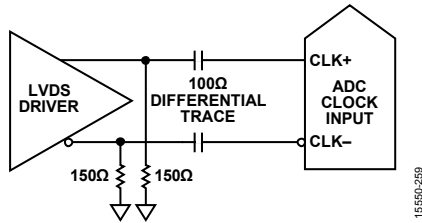

Figure 89. Differential LVPECL Sample Clock

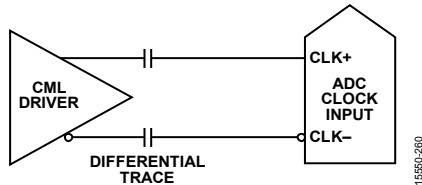

Figure 90. Differential CML Sample Clock

In some instances, the RF DAC series such as the AD9172 has a synthesizer that can output a clock output to clock the AD9689. Figure 91 shows the arrangement where the AD9172 clock outputs clock the AD9689.

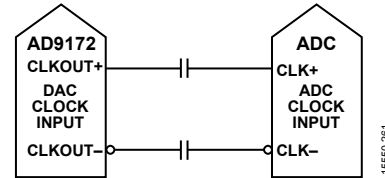

Figure 91. DAC Clock Output Clocking the AD9689

Clock Duty Cycle Considerations

Typical high speed ADCs use both clock edges to generate a variety of internal timing signals. The AD9689 contains an internal clock divider and a duty cycle stabilizer comprised of DCS1 and DCS2, which is enabled by default. In applications where the clock duty cycle cannot be guaranteed to be 50%, a higher multiple frequency clock along with the usage of the clock divider is recommended.

When it is not possible to provide a higher frequency clock, it is recommended to turn on the DCS using Register 0x011C and Register 0x011E. Figure 92 shows the different controls to the AD9689 clock inputs. The output of the divider offers a 50% duty cycle, high slew rate (fast edge) clock signal to the internal ADC. See the Memory Map section for more details on using this feature.

Input Clock Divider

The AD9689 contains an input clock divider with the ability to divide the input clock by 1, 2, or 4. Select the divider ratios using Register 0x0108 (see Figure 92).

The maximum frequency at the CLK± inputs is 6 GHz, which is the limit of the divider. In applications where the clock input is a multiple of the sample clock, take care to program the appropriate divider ratio into the clock divider before applying the clock signal; this ensures that the current transients during device startup are controlled.

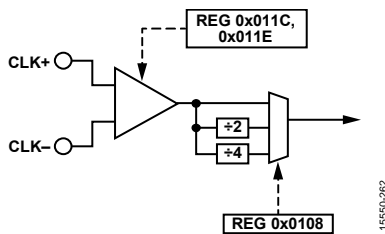

Figure 92. Clock Divider Circuit

The AD9689 clock divider can be synchronized using the external SYSREF± input. A valid SYSREF± signal causes the clock divider to reset to a programmable state. This synchronization feature allows multiple devices to have their clock dividers aligned to guarantee simultaneous input sampling. See the Memory Map Register Details section for more information.

Input Clock Divider ½ Period Delay Adjust

The input clock divider in the AD9689 provides phase delay in increments of ½ the input clock cycle. Program Register 0x0109 to enable this delay independently for each channel. Changing this register does not affect the stability of the JESD204B link.

Clock Fine Delay and Superfine Delay Adjust

Adjust the AD9689 sampling edge instant by writing to Register 0x0110, Register 0x0111, and Register 0x0112. Bits[2:0] of Register 0x0110 enable the selection of the fine delay, or the fine delay with superfine delay. The fine delay allows the user to delay the clock edges with 16-step or 192-step delay options. The superfine delay is an unsigned control to adjust the clock delay in superfine steps of 0.25 ps each.

Register 0x0112, Bits[7:0] offer the user the option to delay the clock in 192 delay steps. Register 0x0111, Bits[7:0] offer the user the option to delay the clock in 128 superfine steps. These values can be programmed individually for each channel. To use the superfine delay option, set the clock delay control in Register 0x0110, Bits[2:0] to 0x2 or 0x6. Figure 93 shows the controls available to the clock dividers within AD9689. It is recommended to apply the same delay settings to the digital delay circuits as are applied to the analog delay circuits to maintain sample accuracy through the pipe.

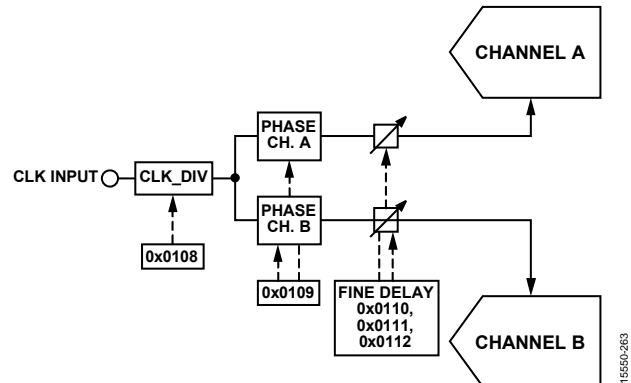

Figure 93. Clock Divider Phase and Delay Controls

The clock delay adjustment takes effect immediately when it is enabled via SPI writes. Enabling the clock fine delay adjust in Register 0x0110 causes a datapath reset. However, the contents of Register 0x0111 and Register 0x0112 can be changed without affecting the stability of the JESD204B link.

Clock Coupling Considerations

The AD9689 has many different domains within the analog supply that control various aspects of the data conversion. The clock domain is supplied by Pin A4, Pin A5, Pin A10, Pin A11, Pin B4, and Pin B11 on the analog supply, AVDD1 (0.975 V) and Pin A6, Pin A9, Pin B6, Pin B7, Pin B8, Pin B9, Pin C6, Pin C7, Pin C8, Pin C9, Pin D7, and Pin D8 on the ground (AGND) side. To minimize coupling between the clock supply domain and the other analog domains, it is recommended to add a supply Q factor reduction circuitry for Pin A4 and Pin A11, as well as Pin B4 and Pin B11, as shown in Figure 94.

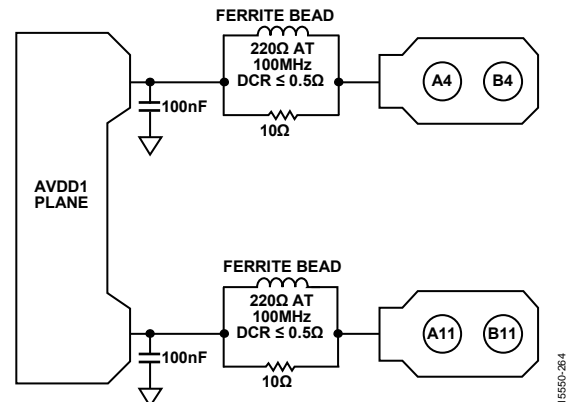

Figure 94. Q Factor Reduction Network Recommendation for the Clock Domain Supply

Clock Jitter Considerations

High speed, high resolution ADCs are sensitive to the quality of the clock input. Calculate the degradation in SNR at a given input frequency (f_A) due only to aperture jitter (t_j) by

$$SNR_{JITTER} = -20 \times \log_{10} (2 \times \pi \times f_A \times t_j)$$

In this equation, the rms aperture jitter represents the root mean square of all jitter sources, including the clock input, analog input signal, and ADC aperture jitter specifications.

Intermediate frequency (IF) undersampling applications are particularly sensitive to jitter (see Figure 95).

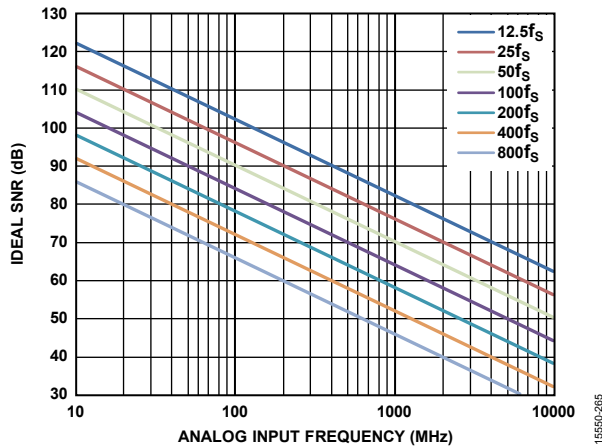

Figure 95. Ideal SNR vs. Analog Input Frequency and Jitter

Treat the clock input as an analog signal when aperture jitter may affect the dynamic range of the AD9689. Separate power supplies for clock drivers from the ADC output driver supplies to avoid modulating the clock signal with digital noise. If the clock is generated from another type of source (by gating, dividing, or other methods), retime the clock by the original clock at the last step. Refer to the [AN-501 Application Note](#) and the [AN-756 Application Note](#) for more information about jitter performance as it relates to ADCs.

Figure 96 shows the estimated SNR of the AD9689 across input frequency for different clock induced jitter values. Estimate the SNR by using the following equation:

$$SNR \text{ (dBFS)} = -10 \log_{10} \left(10^{\left(\frac{-SNR_{ADC}}{10} \right)} + 10^{\left(\frac{-SNR_{JITTER}}{10} \right)} \right)$$

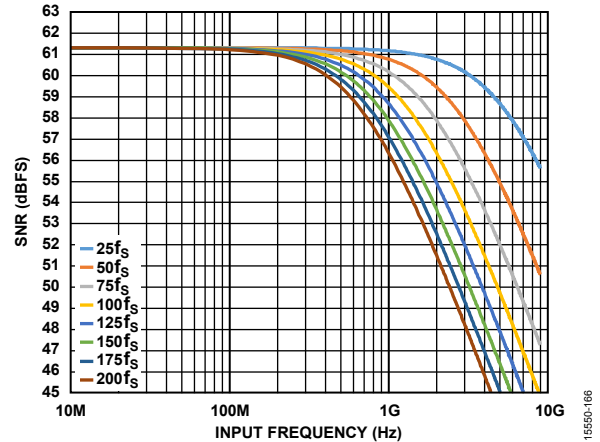

Figure 96. Estimated SNR Degradation vs. Input Frequency and RMS Jitter for the 2.6 GSPS

POWER-DOWN AND STANDBY MODE

The AD9689 has a PDWN/STBY pin that can be used to configure the device in power-down or standby mode. The default operation is PDWN. The PDWN/STBY pin is a logic high pin. When in power-down mode, the JESD204B link is disrupted. The power-down option can also be set via Register 0x003F and Register 0x0040.

In standby mode, the JESD204B link is not disrupted and transmits zeros for all converter samples. Change this transmission using Register 0x0571, Bit 7 to select /K/ characters.

TEMPERATURE DIODE

The AD9689 contains diode-based temperature sensors. The diodes output voltages commensurate to the temperature of the silicon. There are multiple diodes on the die, but the results established using the temperature diode at the central location of the die can be regarded as representative of the entire die. However, in applications where only one channel is used (the other channel being in a power-down state), it is recommended to read the temperature diode corresponding to the channel that is on. Figure 97 shows the locations of the diodes in the AD9689 with voltages that can be output to the VREF pin. In each location, there is a pair of diodes, one of which is 20x the size of the other. It is recommended to use both diodes in a location to obtain an accurate estimate of the die temperature. For more information, see the [AN-1432 Application Note](#).

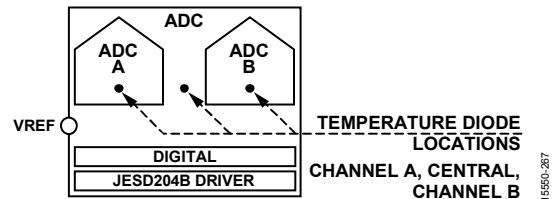

Figure 97. Temperature Diode Locations in the Die

The temperature diode voltages can be exported to the VREF pin using the SPI. Use Register 0x18E6 to enable or disable diodes. It is important to note that other voltages may be exported to the VREF pin at the same time, which may result in undefined behavior. To ensure a proper readout, switch off all other voltage exporting circuits as described in this section. Figure 98 shows the block diagram of the controls that are required to enable the diode voltage readout.

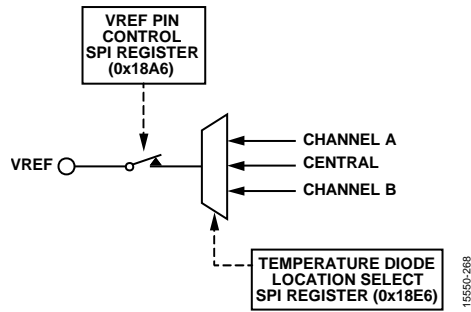

Figure 98. Register Controls to Output Temperature Diode Voltage on the VREF Pin

The SPI writes required to export the central temperature diode are as follows (see Table 46 and Table 53 for more information):

1. Set Register 0x0008 to 0x03 to select both channels.
2. Set Register 0x18E3 to 0x00 to turn off V_{CM} export.
3. Set Register 0x18A6 to 0x00 to turn off voltage reference export.
4. Set Register 0x18E6 to 0x01 to turn on voltage export of the central 1× temperature diode. The typical voltage response of the temperature diode is shown in Figure 99. Although this voltage represents the die temperature, it is recommended to take measurements from a pair of diodes for improved accuracy. Step 5 explains how to enable the 20× diode.
5. Set Register 0x18E6 to 0x02 to turn on the second central temperature diode of the pair, which is 20× the size of the first. For the method using two diodes simultaneously to achieve a more accurate result, see the [AN-1432 Application Note](#).

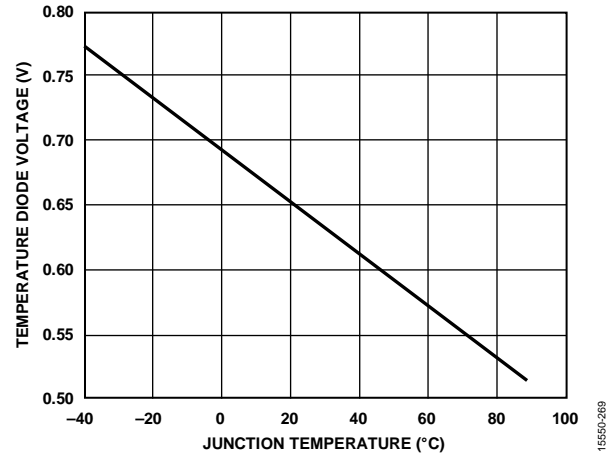

Figure 99. Typical Voltage Response of the 1× Temperature Diode

The relationship between the measured delta voltage (ΔV) and the junction temperature in °C is shown in Figure 100.

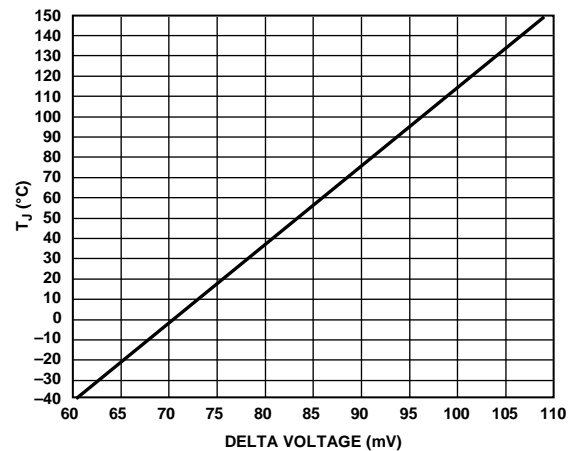

Figure 100. Junction Temperature vs. ΔV (mV)

ADC OVERRANGE AND FAST DETECT

In receiver applications, it is desirable to have a mechanism to reliably determine when the converter is about to be clipped. The standard overrange bit in the JESD204B outputs provides information on the state of the analog input that is of limited usefulness. Therefore, it is helpful to have a programmable threshold below full scale that allows time to reduce the gain before the clip actually occurs. In addition, because input signals can have significant slew rates, the latency of this function is of major concern. Highly pipelined converters can have significant latency. The AD9689 contains fast detect circuitry for individual channels to monitor the threshold and assert the FD_A and FD_B pins.

ADC OVERRANGE

The ADC overrange indicator is asserted when an overrange is detected on the input of the ADC. The overrange indicator can be embedded within the JESD204B link as a control bit (when CSB > 0). The latency of this overrange indicator matches the sample latency.

The AD9689 also records any overrange condition in any of the eight virtual converters. For more information on the virtual converters, refer to Figure 109. The overrange status of each virtual converter is registered as a sticky bit in Register 0x0563. The contents of Register 0x0563 can be cleared using Register 0x0562, by toggling the bits corresponding to the virtual converter to set and reset position.

FAST THRESHOLD DETECTION (FD_A AND FD_B)

The FD_A or FD_B pin is immediately set whenever the absolute value of the input signal exceeds the programmable upper threshold level. The FD bit is only cleared when the absolute value of the input signal drops below the lower threshold level for greater than the programmable dwell time. This feature provides hysteresis and prevents the FD bit from excessively toggling.

The operation of the upper threshold and lower threshold registers, along with the dwell time registers, is shown in Figure 101.

The FD indicator is asserted if the input magnitude exceeds the value programmed in the fast detect upper threshold registers, located at Register 0x0247 and Register 0x0248. The selected threshold register is compared with the signal magnitude at the output of the ADC. The fast upper threshold detection has a latency of 28 clock cycles (maximum). The approximate upper threshold magnitude is defined by

$$\text{Upper Threshold Magnitude (dBFS)} = 20\log(\text{Threshold Magnitude}/2^{13})$$

The FD indicators are not cleared until the signal drops below the lower threshold for the programmed dwell time. The lower threshold is programmed in the fast detect lower threshold registers, located at Register 0x0249 and Register 0x024A. The fast detect lower threshold register is a 13-bit register that is compared with the signal magnitude at the output of the ADC. This comparison is subject to the ADC pipeline latency, but is accurate in terms of converter resolution. The lower threshold magnitude is defined by

$$\text{Lower Threshold Magnitude (dBFS)} = 20\log(\text{Threshold Magnitude}/2^{13})$$

For example, to set an upper threshold of -6 dBFS, write 0xFFF to Register 0x0247 and Register 0x0248. To set a lower threshold of -10 dBFS, write 0xA1D to Register 0x0249 and Register 0x024A.

The dwell time can be programmed from 1 to 65,535 sample clock cycles by placing the desired value in the fast detect dwell time registers, located at Register 0x024B and Register 0x024C. See Register 0x0040 and Register 0x0245 to Register 0x024C in the Memory Map section (see Table 46, Table 47, and Table 49) for more details.

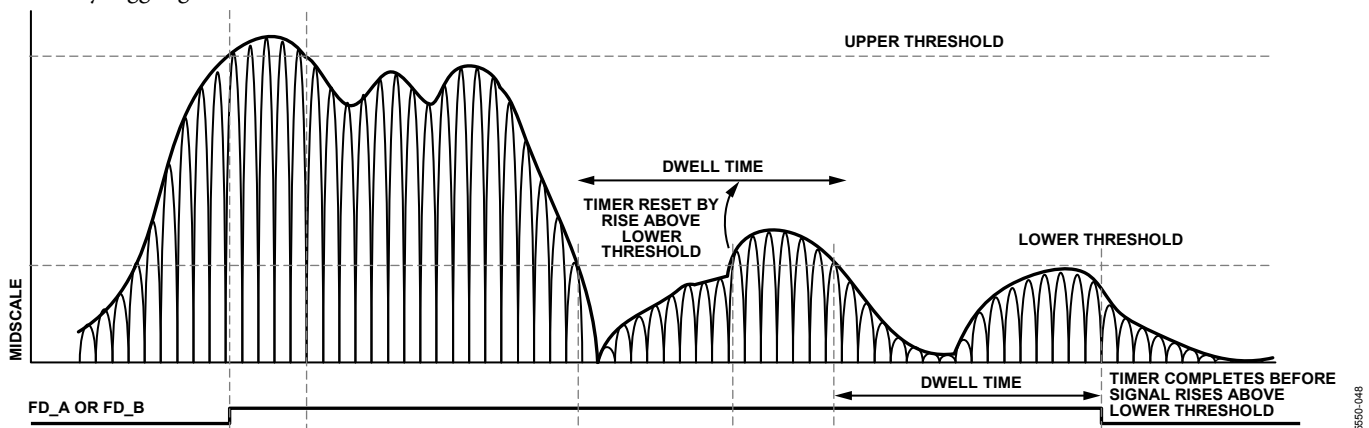

Figure 101. Threshold Settings for the FD_A and FD_B Signals

ADC APPLICATION MODES AND JESD204B Tx CONVERTER MAPPING

The AD9689 contains a configurable signal path that allows different features to be enabled for different applications. These features are controlled using the chip mode register, Register 0x0200. The chip operating mode is controlled by Bits[3:0] in this register, and the chip Q ignore is controlled by Bit 5.

The AD9689 contains the following modes:

- Full bandwidth mode: two 14-bit ADC cores running at full sample rate.
- DDC mode: up to four DDC channels.

After the chip application mode is selected, the output decimation ratio is set using the chip decimation ratio in Register 0x0201, Bits[3:0]. The output sample rate = ADC sample rate/the chip decimation ratio.

To support the different application layer modes, the AD9689 treats each sample stream (real, I, or Q) as originating from separate virtual converters.

Table 11 shows the number of virtual converters required and the transport layer mapping when channel swapping is disabled. Figure 102 shows the virtual converters and their relationship to the DDC outputs when complex outputs are used.

Each DDC channel outputs either two sample streams (I/Q) for the complex data components (real + imaginary), or one sample stream for real (I) data. The AD9689 can be configured to use up to eight virtual converters, depending on the DDC configuration.

The I/Q samples are always mapped in pairs with the I samples mapped to the first virtual converter and the Q samples mapped to the second virtual converter. With this transport layer mapping, the number of virtual converters are the same whether a single real converter is used along with a digital downconverter block producing I/Q outputs, or whether an analog downconversion is used with two real converters producing I/Q outputs.

Figure 103 shows a block diagram of the two scenarios described for I/Q transport layer mapping.

Table 11. Virtual Converter Mapping

Number of Virtual Converters Supported	Chip Application Mode (Reg. 0x0200, Bits[3:0])	Chip Q Ignore (Reg. 0x0200, Bit 5)	Virtual Converter Mapping								
			0	1	2	3	4	5	6	7	
1 to 2	Full bandwidth mode (0x0)	Real or complex (0x0)	ADC A samples	ADC B samples	Unused	Unused	Unused	Unused	Unused	Unused	Unused
1	One DDC mode (0x1)	Real (I only) (0x1)	DDC0 I samples	Unused	Unused	Unused	Unused	Unused	Unused	Unused	Unused
2	One DDC mode (0x1)	Complex (I/Q) (0x0)	DDC0 I samples	DDC0 Q samples	Unused	Unused	Unused	Unused	Unused	Unused	Unused
2	Two DDC mode (0x2)	Real (I only) (0x1)	DDC0 I samples	DDC1 I samples	Unused	Unused	Unused	Unused	Unused	Unused	Unused
4	Two DDC mode (0x2)	Complex (I/Q) (0x0)	DDC0 I samples	DDC0 Q samples	DDC1 I samples	DDC1 Q samples	Unused	Unused	Unused	Unused	Unused
4	Four DDC mode (0x3)	Real (I only) (0x1)	DDC0 I samples	DDC1 I samples	DDC2 I samples	DDC3 I samples	Unused	Unused	Unused	Unused	Unused
8	Four DDC mode (0x3)	Complex (I/Q) (0x0)	DDC0 I samples	DDC0 Q samples	DDC1 I samples	DDC1 Q samples	DDC2 I samples	DDC2 Q samples	DDC3 I samples	DDC3 Q samples	Unused

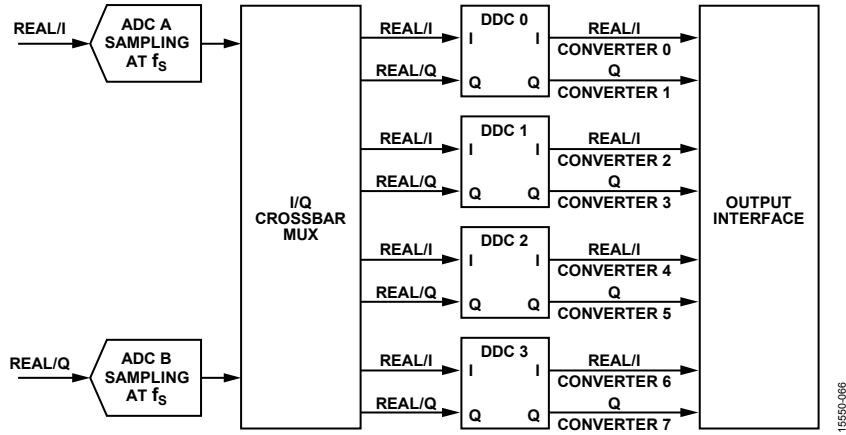

Figure 102. DDCs and Virtual Converter Mapping

15550-066

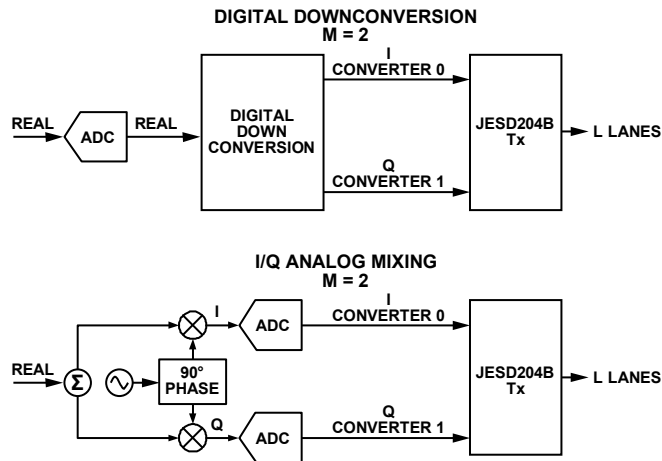

Figure 103. I/Q Transport Layer Mapping

15550-065

PROGRAMMABLE FIR FILTERS

SUPPORTED MODES

The AD9689 supports the following modes of operation (the asterisk symbol (*) denotes convolution):

- Real 48-tap filter for each I/Q channel (see Figure 104)
 - $DOUT_I[n] = DIN_I[n] * XY_I[n]$
 - $DOUT_Q[n] = DIN_Q[n] * XY_Q[n]$
- Real 96-tap filter for on either I or Q channel (see Figure 105)
 - $DOUT_I[n] = DIN_I[n] * XY_I_XY_Q[n]$
 - $DOUT_Q[n] = DIN_Q[n]$
- Real set of two cascaded 24-tap filters for each I/Q channel (see Figure 106)
 - $DOUT_I[n] = DIN_I[n] * X_I[n] * Y_I[n]$
 - $DOUT_Q[n] = DIN_Q[n] * X_Q[n] * Y_Q[n]$
- Half complex filter using two real 48-tap filters for the I/Q channels (see Figure 107)
 - $DOUT_I[n] = DIN_I[n]$
 - $DOUT_Q[n] = DIN_Q[n] * XY_Q[n] + DIN_I[n] * XY_I[n]$
- Full complex filter using four real 24-tap filters for the I/Q channels (see Figure 108)
 - $DOUT_I[n] = DIN_I[n] * X_I[n] + DIN_Q[n] * Y_Q[n]$
 - $DOUT_Q[n] = DIN_Q[n] * X_Q[n] + DIN_I[n] * Y_I[n]$

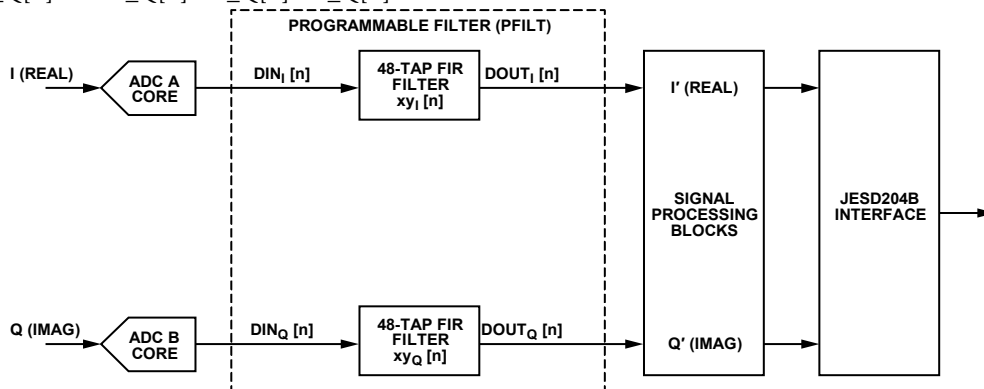

Figure 104. Real 48-Tap Filter Configuration

15550-274

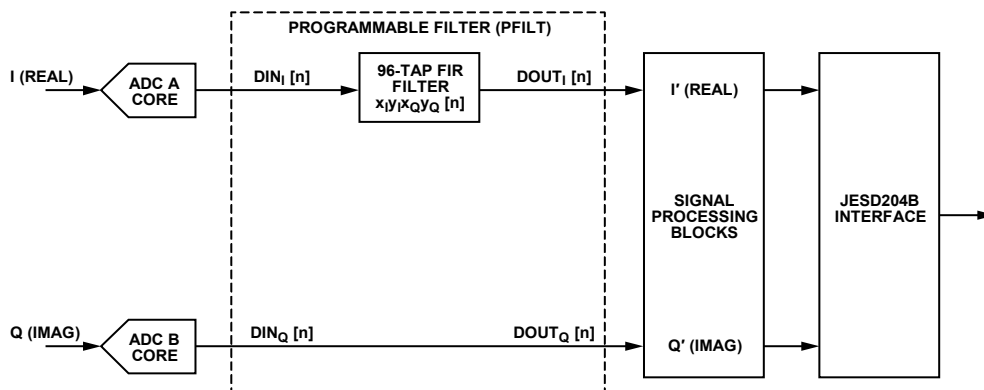

Figure 105. Real 96-Tap Filter Configuration

15550-275

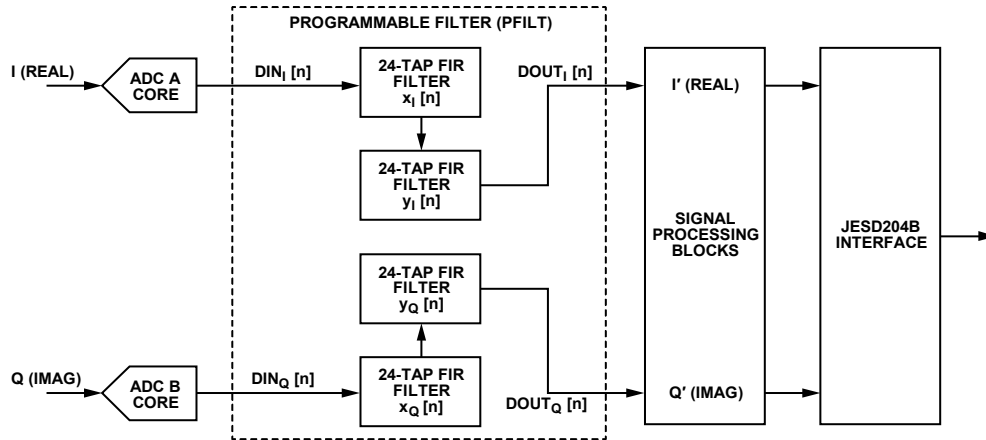

Figure 106. Real, Two Cascaded, 24-Tap Filter Configuration

15550-276

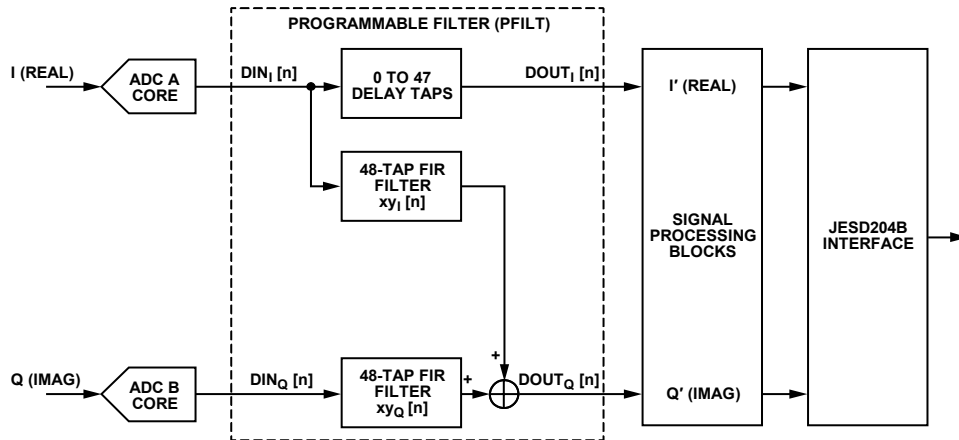

Figure 107. 48-Tap Half Complex Filter Configuration

15550-277

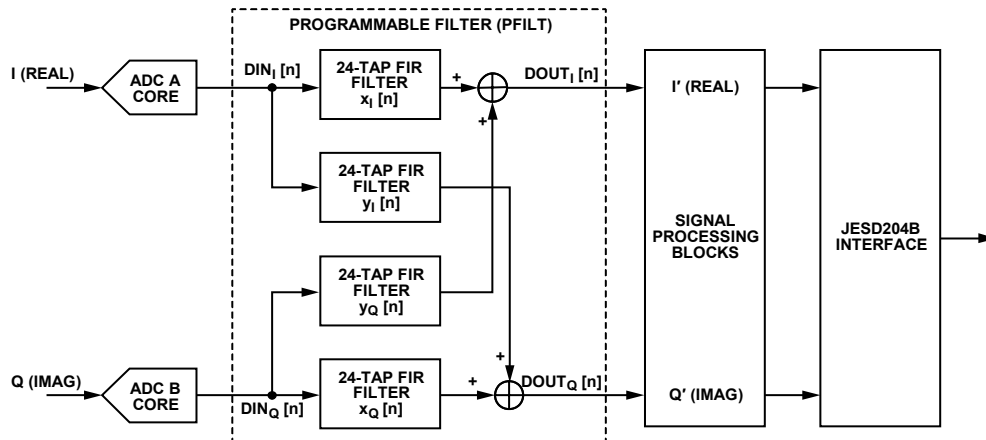

Figure 108. 24-Tap Full Complex Filter Configuration.

15550-278

PROGRAMMING INSTRUCTIONS

Use the following procedure to set up the programmable FIR filter:

1. Enable the sample clock to the device.
2. Configure the mode registers as follows:
 - a. Set the device index to Channel A (I path) (Register 0x0008 = 0x01).
 - b. Set the I path mode (I mode) and gain in Register 0x0DF8 and Register 0x0DF9 (see Table 12 and Table 13).
 - c. Set the device index to Channel B (Q path) (Register 0x0008 = 0x02).
 - d. Set the Q path mode (Q mode) and gain in Register 0x0DF8 and Register 0x0DF9.
3. Wait at least 5 μ s to allow the programmable filter to power up.
4. Program the I path coefficients to the internal shadow registers as follows:
 - a. Set the device index to Channel A (I path) (Register 0x0008 = 0x01).
 - b. Program the XI coefficients in Register 0x0E00 to Register 0x0E7F (see Table 14 and Table 15).
 - c. Program the YI coefficients in Register 0x0F00 to Register 0x0E7F (see Table 14 and Table 15).
 - d. Program the tapped delay in Register 0x0F30 (note that this step is optional).
5. Program the Q path coefficients to the internal shadow registers as follows:
 - a. Set the device index to Channel B (Q path) (Register 0x0008 = 0x02).
 - b. Set the Q path mode and gain in Register 0x0DF8 and Register 0x0DF9 (see Table 12 and Table 13).
 - c. Program the XQ coefficients in Register 0x0E00 to Register 0x0E7F (see Table 14 and Table 15).
 - d. Program the YQ coefficients in Register 0x0F00 to Register 0x0E7F (see Table 14 and Table 15).
 - e. Program the tapped delay in Register 0x0F30 (note that this step is optional).
6. Set the chip transfer bit using either of the following methods (note that setting the chip transfer bit applies the programmed shadow coefficients to the filter):
 - a. Via the register map by setting the chip transfer bit (Register 0x000F = 0x01).
 - b. Via a GPIO pin, as follows:
 - i. Configure one of the GPIO pins as the chip transfer bit in Register 0x0040 to Register 0x0042.
 - ii. Toggle the GPIO pin to initiate the chip transfer (the rising edge is triggered).
7. When the I or Q path mode register changes in Register 0x0DF8, all coefficients must be reprogrammed.

Table 12. Register 0x0DF8 Definition

Bit(s)	Description
[7:3]	Reserved
[2:0]	Filter mode (I mode or Q mode) 000: filters bypassed 001: real 24-tap filter (X only) 010: real 48-tap filter (X and Y together) 100: real set of two cascaded 24-tap filters (X then Y cascaded) 101: full complex filter using four real 24-tap filters for Channel A or Channel B (opposite channel must also be set to 101) 110: half complex filter using two real 48-tap filters + 48-tap delay line (X and Y together) (opposite channel must also be set to 010) 111: real 96-tap filter (XI, YI, XQ, and YQ together) (opposite channel must be set to 000)

Table 13. Register 0x0DF9 Definition

Bit(s)	Description
7	Reserved
[6:4]	Y filter gain 110: -12 dB loss 111: -6 dB loss 000: 0 dB gain 001: 6 dB gain 010: 12 dB gain
3	Reserved
[2:0]	X filter gain 110: -12 dB loss 111: -6 dB loss 000: 0 dB gain 001: 6 dB gain 010: 12 dB gain

Table 14 and Table 15 show the coefficient tables in Register 0x0E00 to Register 0x0F30. Note that all coefficients are in Q1.15 format (sign bit plus 15 fractional bits).

Table 14. I Coefficient Table (Device Selection = 0x1)¹

Addr.	Single 24-Tap Filter (I Mode [2:0] = 0x1)	Single 48-Tap Filter (I Mode [2:0] = 0x2)	Two Cascaded 24-Tap Filters (I Mode [2:0] = 0x4)	Full Complex 24-Tap Filters (I Mode [2:0] = 0x5 and Q Mode [2:0] = 0x5)	Half Complex 48-Tap Filters (I Mode [2:0] = 0x6 and Q Mode [2:0] = 0x2) ²	I Path 96-Tap Filter (I Mode [2:0] = 0x7 and Q Mode [2:0] = 0x0) ³	Q Path 96-Tap Filter (I Mode [2:0] = 0x0 and Q Mode [2:0] = 0x7) ³
0x0E00	XI C0 [7:0]	XI C0 [7:0]	XI C0 [7:0]	XI C0 [7:0]	XI C0 [7:0]	XI C0 [7:0]	XQ C48 [7:0]
0x0E01	XI C0 [15:8]	XI C0 [15:8]	XI C0 [15:8]	XI C0 [15:8]	XI C0 [15:8]	XI C0 [15:8]	XQ C48 [15:8]
0x0E02	XI C1 [7:0]	XI C1 [7:0]	XI C1 [7:0]	XI C1 [7:0]	XI C1 [7:0]	XI C1 [7:0]	XQ C49 [7:0]
0x0E03	XI C1 [15:8]	XI C1 [15:8]	XI C1 [15:8]	XI C1 [15:8]	XI C1 [15:8]	XI C1 [15:8]	XQ C49 [15:8]
...
0x0E2E	XI C23 [7:0]	XI C23 [7:0]	XI C23 [7:0]	XI C23 [7:0]	XI C23 [7:0]	XI C23 [7:0]	XQ C71 [7:0]
0x0E2F	XI C23 [15:0]	XI C23 [15:0]	XI C23 [15:0]	XI C23 [15:0]	XI C23 [15:0]	XI C23 [15:0]	XQ C71 [15:0]
0x0F00	Unused	YI C24 [7:0]	YI C0 [7:0]	YI C0 [7:0]	YI C24 [7:0]	YI C24 [7:0]	YQ C72 [7:0]
0x0F01	Unused	YI C24 [15:8]	YI C0 [15:8]	YI C0 [15:8]	YI C24 [15:8]	YI C24 [15:8]	YQ C72 [15:8]
0x0F02	Unused	YI C25 [7:0]	YI C1 [7:0]	YI C1 [7:0]	YI C25 [7:0]	YI C25 [7:0]	YQ C73 [7:0]
0x0F03	Unused	YI C25 [15:8]	YI C1 [15:8]	YI C1 [15:8]	YI C25 [15:8]	YI C25 [15:8]	YQ C73 [15:8]
...
0x0F2E	Unused	YI C47 [7:0]	YI C23 [7:0]	YI C23 [7:0]	YI C47 [7:0]	YI C47 [7:0]	YQ C95 [7:0]
0x0F2F	Unused	YI C47 [15:0]	YI C23 [15:0]	YI C23 [15:0]	YI C47 [15:0]	YI C47 [15:0]	YQ C95 [15:0]
0x0F30	Unused	Unused	Unused	Unused	I path tapped delay 0: 0 tapped delay (matches C0 in the filter) 1: 1 tapped delays ... 47: 47 tapped delays	Unused	Unused

¹ XI Cn means I Path X Coefficient n. YI Cn means I Path Y Coefficient n.

² When using the I path in half-complex 48-tap filter mode, the Q path must be in single 48-tap filter mode.

³ When using the I path in 96-tap filter mode, the Q path must be in bypass mode.

Table 15. Q Coefficient Table (Device Selection = 0x2)¹

Addr.	Single 24-Tap Filter (Q Mode [2:0] = 0x1)	Single 48-Tap Filter (Q Mode [2:0] = 0x2)	Two Cascaded 24-Tap Filters (Q Mode [2:0] = 0x4)	Full Complex 24-Tap Filters (Q Mode [2:0] = 0x5 and I Mode [2:0] = 0x5)	Half Complex 48-Tap Filters (Q Mode [2:0] = 0x6 and I Mode [2:0] = 0x2) ²	I Path 96-Tap Filter (Q Mode [2:0] = 0x0 and I Mode [2:0] = 0x7) ³	Q Path 96-Tap Filter (Q Mode [2:0] = 0x7 and I Mode [2:0] = 0x0) ³
0x0E00	XQ C0 [7:0]	XQ C0 [7:0]	XQ C0 [7:0]	XQ C0 [7:0]	XQ C0 [7:0]	XI C48 [7:0]	XQ C0 [7:0]
0x0E01	XQ C0 [15:8]	XQ C0 [15:8]	XQ C0 [15:8]	XQ C0 [15:8]	XQ C0 [15:8]	XI C48 [15:8]	XQ C0 [15:8]
0x0E02	XQ C1 [7:0]	XQ C1 [7:0]	XQ C1 [7:0]	XQ C1 [7:0]	XQ C1 [7:0]	XI C49 [7:0]	XQ C1 [7:0]
0x0E03	XQ C1 [15:8]	XQ C1 [15:8]	XQ C1 [15:8]	XQ C1 [15:8]	XQ C1 [15:8]	XI C49 [15:8]	XQ C1 [15:8]
...
0x0E2E	XQ C23 [7:0]	XQ C23 [7:0]	XQ C23 [7:0]	XQ C23 [7:0]	XQ C23 [7:0]	XI C71 [7:0]	XQ C23 [7:0]
0x0E2F	XQ C23 [15:0]	XQ C23 [15:0]	XQ C23 [15:0]	XQ C23 [15:0]	XQ C23 [15:0]	XI C71 [15:0]	XQ C23 [15:0]
0x0F00	Unused	YQ C24 [7:0]	YQ C0 [7:0]	YQ C0 [7:0]	YQ C24 [7:0]	YI C72 [7:0]	YQ C24 [7:0]
0x0F01	Unused	YQ C24 [15:8]	YQ C0 [15:8]	YQ C0 [15:8]	YQ C24 [15:8]	YI C72 [15:8]	YQ C24 [15:8]
0x0F02	Unused	YQ C25 [7:0]	YQ C1 [7:0]	YQ C1 [7:0]	YQ C25 [7:0]	YI C73 [7:0]	YQ C25 [7:0]
0x0F03	Unused	YQ C25 [15:8]	YQ C1 [15:8]	YQ C1 [15:8]	YQ C25 [15:8]	YI C73 [15:8]	YQ C25 [15:8]
...
0x0F2E	Unused	YQ C47 [7:0]	YQ C23 [7:0]	YQ C23 [7:0]	YQ C47 [7:0]	YI C95 [7:0]	YQ C47 [7:0]
0x0F2F	Unused	YQ C47 [15:0]	YQ C23 [15:0]	YQ C23 [15:0]	YQ C47 [15:0]	YI C95 [15:0]	YQ C47 [15:0]
0x0F30	Unused	Unused	Unused	Unused	Q path tapped delay 0: 0 tapped delay (matches C0 in the filter) 1: 1 tapped delays ... 47: 47 tapped delays	Unused	Unused

¹ XQ Cn means Q Path X Coefficient n. YQ Cn means Q Path Y Coefficient n.

² When using the I path in half-complex, 48-tap filter mode, the Q path must be in single 48-tap filter mode.

³ When using the I path in 96-tap filter mode, the Q path must be in bypass mode.

DIGITAL DOWNCONVERTER (DDC)

The AD9689 includes four digital downconverters (DDC0 to DDC3) that provide filtering and reduce the output data rate. This digital processing section includes an NCO, multiple decimating FIR filters, a gain stage, and a complex to real conversion stage. Each of these processing blocks has control lines that allow it to be independently enabled and disabled to provide the desired processing function. The digital downconverter can be configured to output either real data or complex output data.

The DDCs output a 16-bit stream. To enable this operation, the converter number of bits, N , is set to a default value of 16, even though the analog core only outputs 14 bits. In full bandwidth operation, the ADC outputs are the 14-bit word followed by two zeros, unless the tail bits are enabled.

DDC I/Q INPUT SELECTION

The AD9689 has two ADC channels and four DDC channels. Each DDC channel has two input ports that can be paired to support both real and complex inputs through the I/Q crossbar mux. For real signals, both DDC input ports must select the same ADC channel (that is, DDC Input Port I = ADC Channel A and DDC Input Port Q = ADC Channel A). For complex signals, each DDC input port must select different ADC channels (that is, DDC Input Port I = ADC Channel A and DDC Input Port Q = ADC Channel B).

The inputs to each DDC are controlled by the DDC input selection registers (Register 0x0311, Register 0x0331, Register 0x0351, and Register 0x0371). See Table 48 and Table 50 for information on how to configure the DDCs.

DDC I/Q OUTPUT SELECTION

Each DDC channel has two output ports that can be paired to support both real and complex outputs. For real output signals, only the DDC Output Port I is used (the DDC Output Port Q is invalid). For complex I/Q output signals, both DDC Output Port I and DDC Output Port Q are used.

The I/Q outputs to each DDC channel are controlled by the DDCx complex to real enable bit, Bit 3, in the DDCx control registers (Register 0x0310, Register 0x0330, Register 0x0350, and Register 0x0370).

The chip Q ignore bit in the chip mode register (Register 0x0200, Bit 5) controls the chip output muxing of all the DDC channels. When all DDC channels use real outputs, set this bit high to ignore all DDC Q output ports. When any of the DDC channels are set to use complex I/Q outputs, the user must clear this bit to use both DDC Output Port I and DDC Output Port Q. For more information, see Figure 126.

DDC GENERAL DESCRIPTION

The four DDC blocks extract a portion of the full digital spectrum captured by the ADC(s). They are intended for IF sampling or oversampled baseband radios requiring wide bandwidth input signals.

Each DDC block contains the following signal processing stages:

- Frequency translation stage (optional)
- Filtering stage
- Gain stage (optional)
- Complex to real conversion stage (optional)

DDC Frequency Translation Stage (Optional)

This stage consists of a phase coherent NCO and quadrature mixers that can be used for frequency translation of both real or complex input signals. The phase coherent NCO allows an infinite number of frequency hops that are all referenced back to a single synchronization event. It also includes 16 shadow registers for fast switching applications. This stage shifts a portion of the available digital spectrum down to baseband.

DDC Filtering Stage

After shifting down to baseband, this stage decimates the frequency spectrum using multiple low-pass finite impulse response (FIR) filters for rate conversion. The decimation process lowers the output data rate, which in turn reduces the output interface rate.

DDC Gain Stage (Optional)

Because of losses associated with mixing a real input signal down to baseband, this stage compensates by adding an additional 0 dB or 6 dB of gain.

DDC Complex to Real Conversion Stage (Optional)

When real outputs are necessary, this stage converts the complex outputs back to real by performing an $f_s/4$ mixing operation plus a filter to remove the complex component of the signal.

Figure 109 shows the detailed block diagram of the DDCs implemented in the AD9689.

Figure 110 shows an example usage of one of the four DDC channels with a real input signal and four half-band filters (HB4 + HB3 + HB2 + HB1) used. It shows both complex (decimate by 16) and real (decimate by 8) output options.

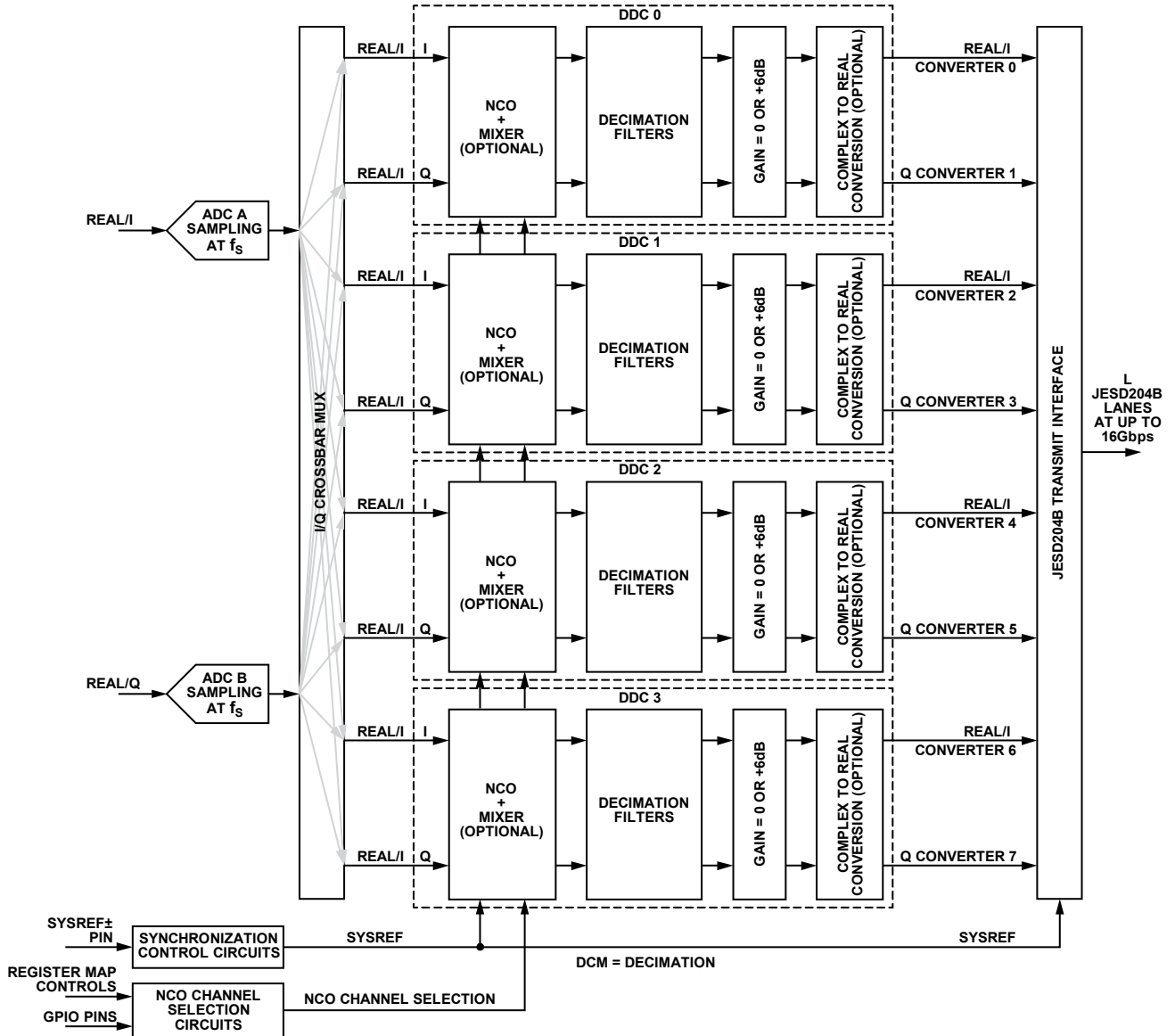

Figure 109. DDC Detailed Block Diagram

15550-063

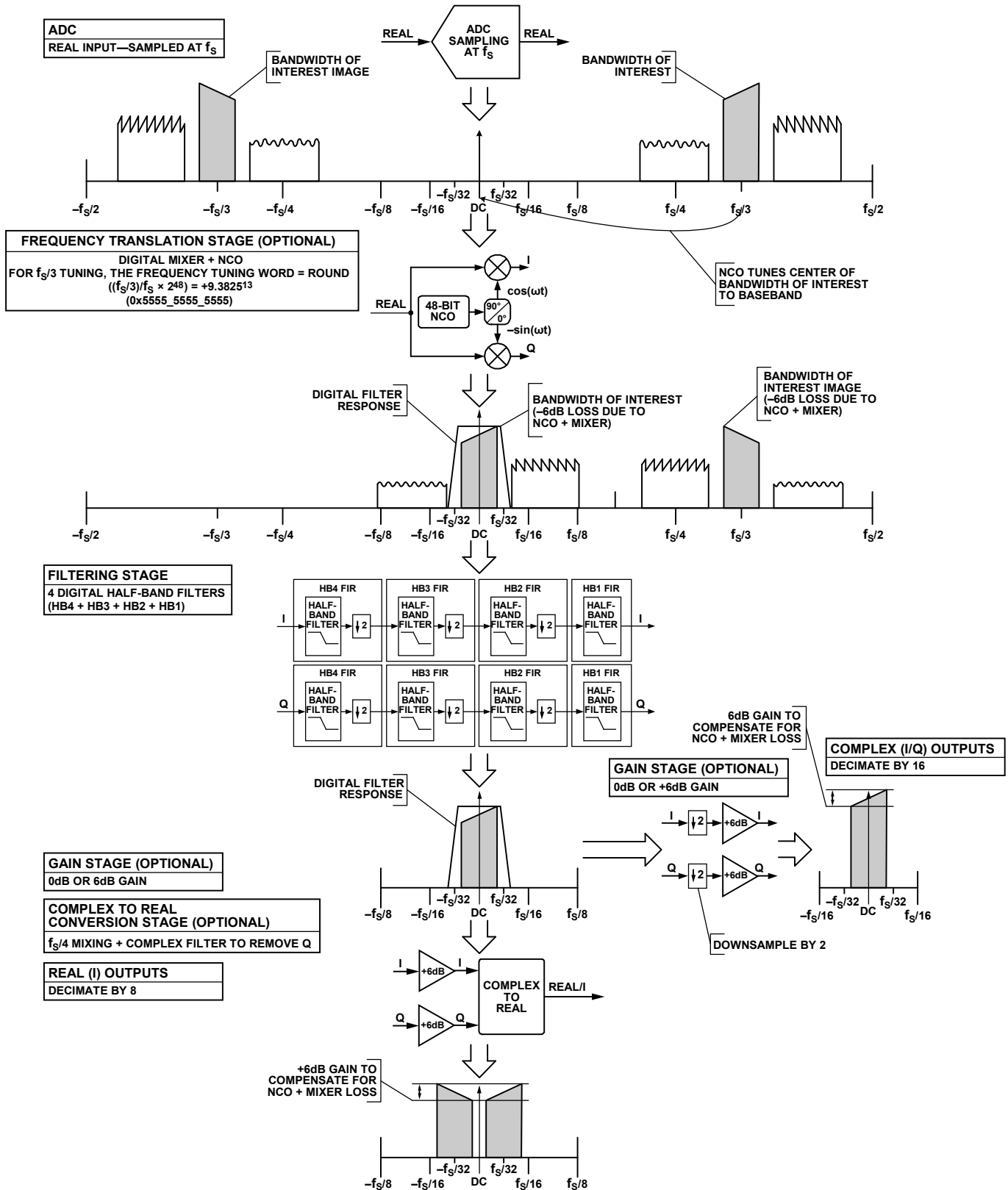

Figure 110. DDC Theory of Operation Example (Real Input)

DDC FREQUENCY TRANSLATION

DDC Frequency Translation General Description

Frequency translation is accomplished by using a 48-bit complex NCO with a digital quadrature mixer. This stage translates either a real or complex input signal from an IF to a baseband complex digital output (carrier frequency = 0 Hz).

The frequency translation stage of each DDC can be controlled individually and supports four different IF modes using Bits[5:4] of the DDCx control registers (Register 0x0310, Register 0x0330, Register 0x0350, and Register 0x0370). These IF modes are

- Variable IF mode
- 0 Hz IF or zero IF (ZIF) mode
- $f_s/4$ Hz IF mode
- Test mode

Variable IF Mode

In variable IF mode, the NCO and mixers are enabled. NCO output frequency can be used to digitally tune the IF frequency.

0 Hz IF (ZIF) Mode

In ZIF mode, the mixers are bypassed, and the NCO is disabled.

$f_s/4$ Hz IF Mode

In $f_s/4$ Hz IF mode, the mixers and the NCO are enabled in downmixing by $f_s/4$ mode to save power.

Test Mode

In test mode, input samples are forced to 0.999 to positive full scale. The NCO is enabled. This test mode allows the NCOs to directly drive the decimation filters.

Figure 111 and Figure 112 show examples of the frequency translation stage for both real and complex inputs, respectively.

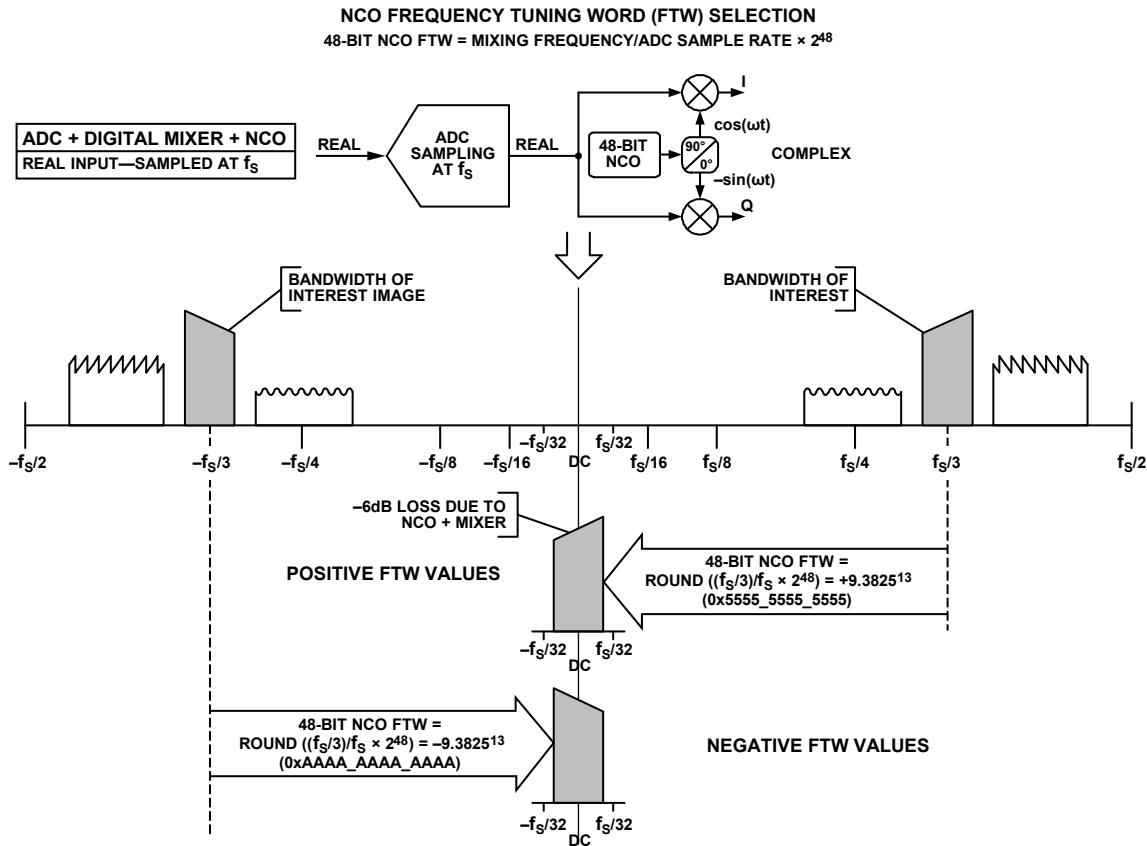

Figure 111. DDC NCO Frequency Tuning Word Selection—Real Inputs

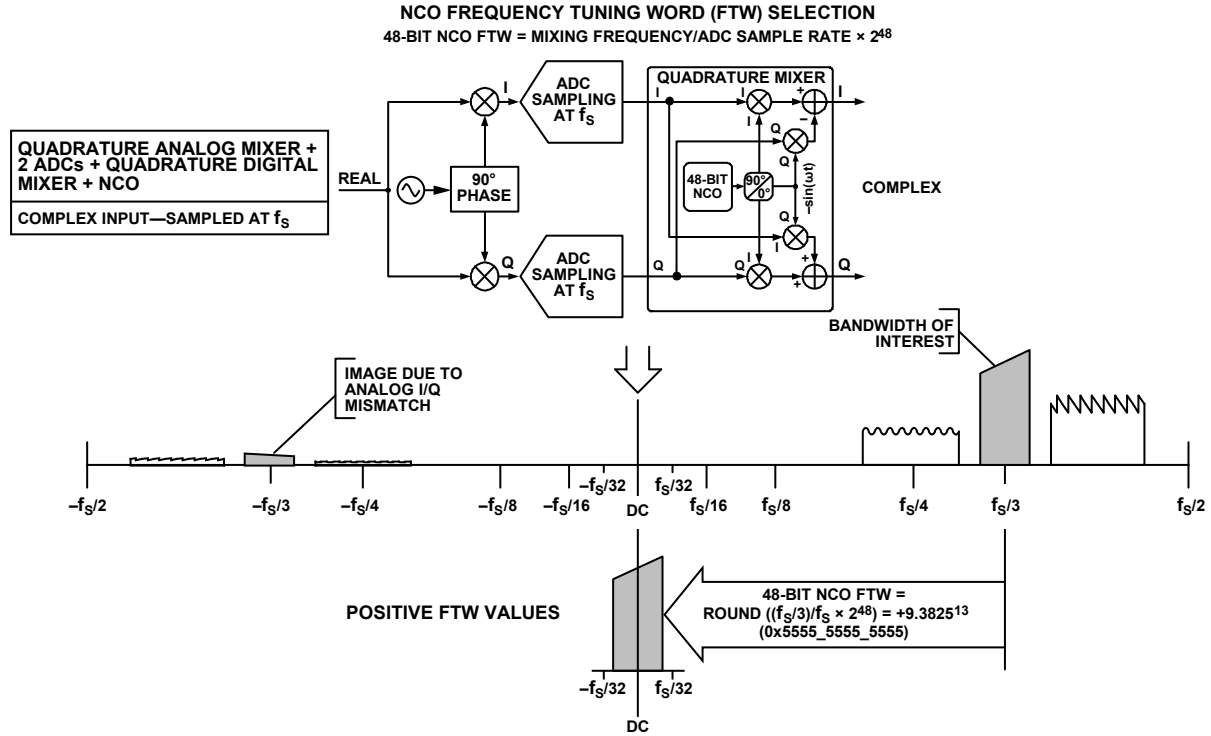

Figure 112. DDC NCO Frequency Tuning Word Selection—Complex Inputs

DDC NCO Description

Each DDC contains one NCO. Each NCO enables the frequency translation process by creating a complex exponential frequency ($e^{j\omega t}$), which can be mixed with the input spectrum to translate the desired frequency band of interest to dc, where it can be filtered by the subsequent low-pass filter blocks to prevent aliasing.

When placed in variable IF mode, the NCO supports two additional modes.

DDC NCO Programmable Modulus Mode

DDC NCO programmable modulus mode supports >48-bit frequency tuning accuracy for applications that require exact rational (M/N) frequency synthesis at a single carrier frequency. In this mode, the NCO is set up by providing the following:

- 48-bit frequency tuning word (FTW)
- 48-bit Modulus A word (MAW)
- 48-bit Modulus B word (MBW)
- 48-bit phase offset word (POW)

DDC NCO Coherent Mode

DDC NCO coherent mode allows an infinite number of frequency hops where the phase is referenced to a single synchronization event at Time 0. This mode is useful when phase coherency must be maintained when switching between different frequency bands. In this mode, the user can switch to any tuning frequency without the need to reset the NCO. Although only one FTW is required, the NCO contains 16 shadow registers for fast switching applications. Selection of the shadow registers is controlled by the CMOS GPIO pins or through the register map of the SPI. In this mode, the NCO can be set up by providing the following:

- Up to sixteen 48-bit FTWs.
- Up to sixteen 48-bit POWs.
- The 48-bit MAW must be set to zero in coherent mode.

Figure 113 shows a block diagram of one NCO and its connection to the rest of the design. The coherent phase accumulator block contains the logic that allows an infinite number of frequency hops. The gray lines in Figure 113 represent SPI control lines.

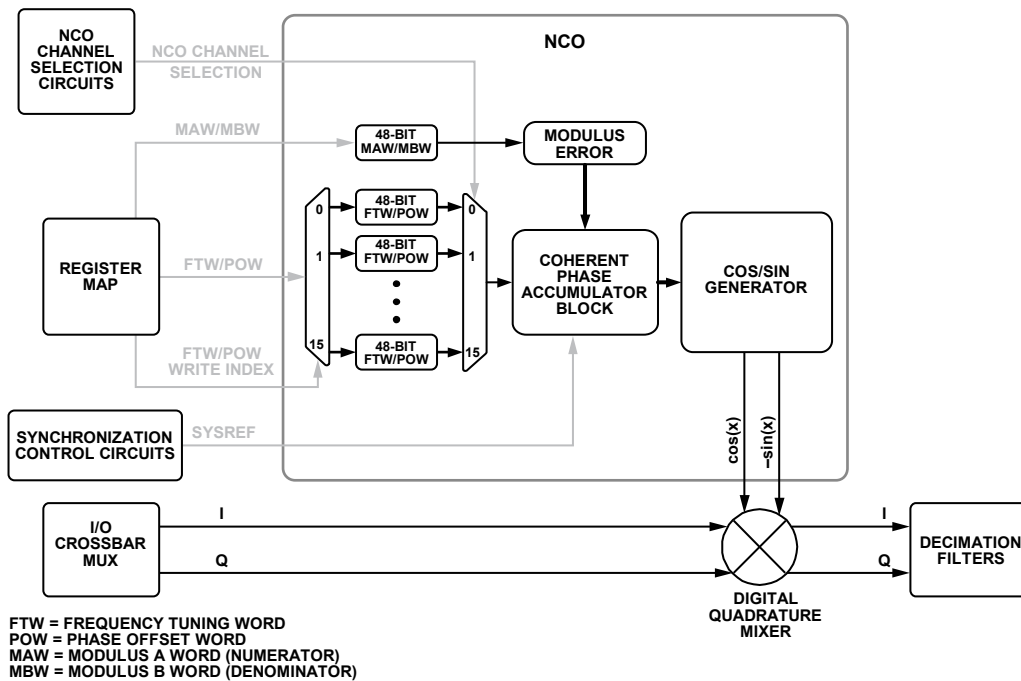

Figure 113. NCO + Mixer Block Diagram

15550-283

NCO FTW/POW/MAW/MAB Description

The NCO frequency value is determined by the following settings:

- 48-bit twos complement number entered in the FTW.
- 48-bit unsigned number entered in the MAW.
- 48-bit unsigned number entered in the MBW.

Frequencies between $-f_s/2$ and $+f_s/2$ ($f_s/2$ excluded) are represented using the following values:

- FTW = 0x8000 0000 0000 and MAW = 0x0000 0000 0000 represents a frequency of $-f_s/2$.
- FTW = 0x0000 0000 0000 and MAW = 0x0000 0000 0000 represents dc (frequency is 0 Hz).
- FTW = 0x7FFF FFFF FFFF and MAW = 0x0000 0000 0000 represents a frequency of $+f_s/2$.

NCO FTW/POW/MAW/MAB Programmable Modulus Mode

For programmable modulus mode, the MAW must be set to a nonzero value (not equal to 0x0000 0000 0000). This mode is only needed when frequency accuracy of >48 bits is required. One example of a rational frequency synthesis requirement that requires >48 bits of accuracy is a carrier frequency of 1/3 the sample rate. When frequency accuracy of ≤ 48 bits is required, coherent mode must be used (see the NCO FTW/POW/MAW/MAB Coherent Mode section).

In programmable modulus mode, the FTW, MAW, and MBW must satisfy the following four equations (for a detailed description of the programmable modulus feature, see the DDS architecture described in the [AN-953 Application Note](#)):

$$\frac{\text{mod}(f_c, f_s)}{f_s} = \frac{M}{N} = \frac{FTW + \frac{MAW}{MBW}}{2^{48}} \quad (1)$$

$$FTW = \text{floor}\left(2^{48} \frac{\text{mod}(f_c, f_s)}{f_s}\right) \quad (2)$$

$$MAW = \text{mod}(2^{48} \times M, N) \quad (3)$$

$$MBW = N \quad (4)$$

where:

f_c is the desired carrier frequency.

f_s is the ADC sampling frequency.

M is the integer representing the rational numerator of the frequency ratio.

N is the integer representing the rational denominator of the frequency ratio.

FTW is the 48-bit twos complement number representing the NCO FTW.

MAW is the 48-bit unsigned number representing the NCO MAW (must be $< 2^{47}$).

MBW is the 48-bit unsigned number representing the NCO MBW.

$\text{mod}(x)$ is a remainder function. For example, $\text{mod}(110, 100) = 10$ and for negative numbers, $\text{mod}(-32, 10) = -2$.

$\text{floor}(x)$ is defined as the largest integer less than or equal to x . For example, $\text{floor}(3.6) = 3$.

Note that Equation 1 to Equation 4 apply to the aliasing of signals in the digital domain (that is, aliasing introduced when digitizing analog signals).

M and N are integers reduced to their lowest terms. MAW and MBW are integers reduced to their lowest terms. When MAW is set to zero, the programmable modulus logic is automatically disabled.

For example, if the ADC sampling frequency (f_s) is 2600 MSPS and the carrier frequency (f_c) is 1001.5 MHz, then

$$\frac{\text{mod}(1001.5, 2600)}{2600} = \frac{M}{N} = \frac{2003}{5200}$$

$$FTW = \text{floor} 2^{48} \left(\frac{\text{mod}(1001.5, 2600)}{2600} \right)$$

$$= 0x629B F68C 3590$$

$$MAW = \text{mod}(2^{48} \times 2003, 5200) = 0x0000 0000 0300$$

$$MBW = 0x0000 0000 1450$$

The actual carrier frequency (f_{c_ACTUAL}) can be calculated based on the following equation:

$$f_{c_ACTUAL} = \frac{FTW + \frac{MAW}{MBW}}{2^{48}} \times f_s$$

For the previous example, the actual carrier frequency (f_{c_ACTUAL}) is

$$\begin{aligned} f_{c_ACTUAL} &= \frac{0x629B F68C 3590 \times \frac{0x0000 0000 0300}{0x0000 0000 1450}}{2^{48}} \\ &= 1001.5\text{MHz} \end{aligned}$$

A 48-bit POW is available for each NCO to create a known phase relationship between multiple chips or individual DDC channels inside the chip.

While in programmable modulus mode, the FTW and POW registers can be updated at any time while still maintaining deterministic phase results in the NCO. However, the following procedure must be followed to update the MAW and/or MBW registers to ensure proper operation of the NCO:

1. Write to the MAW and MBW registers for all the DDCs.
2. Synchronize the NCOs either through the DDC soft reset bit accessible through the SPI or through the assertion of the SYSREF \pm pin (see the Memory Map section).

NCO FTW/POW/MAW/MAB Coherent Mode

For coherent mode, the NCO MAW must be set to zero (0x0000 0000 0000). In this mode, the NCO FTW can be calculated by the following equation:

$$FTW = \text{round}\left(2^{48} \frac{\text{mod}(f_c, f_s)}{f_s}\right) \tag{5}$$

where:

FTW is the 48-bit twos complement number representing the NCO FTW.

f_c is the desired carrier frequency.

f_s is the ADC sampling frequency.

mod(x) is a remainder function. For example mod(110,100) = 10 and for negative numbers, mod(-32,10) = -2.

round(x) is a rounding function. For example round(3.6) = 4 and for negative numbers, round(-3.4) = -3.

Note that Equation 5 applies to the aliasing of signals in the digital domain (that is, aliasing introduced when digitizing analog signals). The MAW must be set to zero to use coherent mode. When MAW is zero, the programmable modulus logic is automatically disabled.

For example, if the ADC sampling frequency (f_s) is 2600 MSPS and the carrier frequency (f_c) is 416.667 MHz, then

$$\begin{aligned} NCO_FTW &= \text{round}\left(2^{48} \frac{\text{mod}(416.667, 2600)}{2600}\right) \\ &= 0x2906\ 928F\ A997 \end{aligned}$$

The actual carrier frequency can be calculated based on the following equation:

$$f_{C_ACTUAL} = \frac{FTW \times f_s}{2^{48}}$$

For the previous example, the actual carrier frequency (f_{C_ACTUAL}) is

$$f_{C_ACTUAL} = \frac{416.667 \times 2600}{2^{48}} = 416.66699 \text{ MHz}$$

A 48-bit POW is available for each NCO to create a known phase relationship between multiple chips or individual DDC channels inside the chip.

While in coherent mode, the FTW and POW registers can be updated at any time while still maintaining deterministic phase results in the NCO.

NCO Channel Selection

When configured in coherent mode, only one FTW is required in the NCO. In this mode, the user can switch to any tuning frequency without the need to reset the NCO by writing to the FTW directly. However, for fast switching applications, where either all FTWs are known beforehand or it is possible to queue up the next set of FTWs, the NCO contains 16 additional shadow registers (see Figure 113). These shadow registers are hereafter referred to as the NCO channels.

Figure 114 shows a simplified block diagram of the NCO channel selection block. The gray lines in Figure 114 represent SPI control lines.

Only one NCO channel is active at a time and NCO channel selection is controlled either by the CMOS GPIO pins or through the register map.

Each NCO channel selector supports three different modes, as described in the following sections.

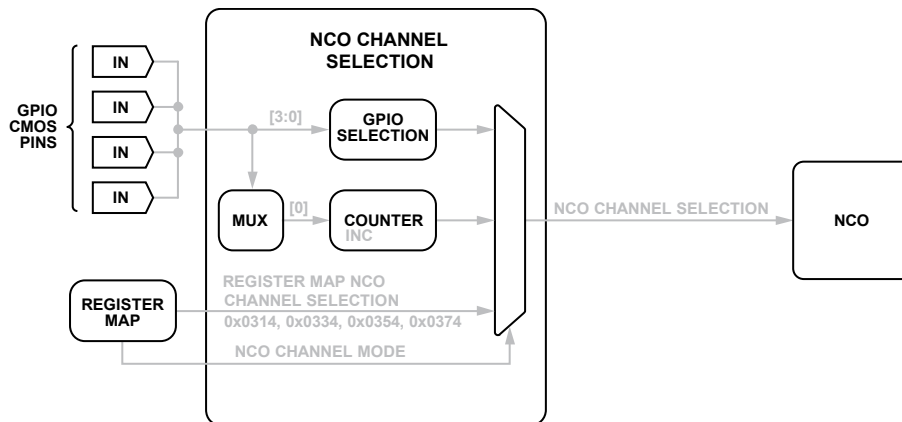

Figure 114. NCO Channel Selection Block

15560-284

GPIO Level Control Mode

The GPIO pins determine the exact NCO channel selected.

The following procedure must be followed to use GPIO level control for NCO channel selection:

1. Configure one or more GPIO pins as NCO channel selection inputs. GPIO pins not configured as NCO channel selection are internally tied low.
 - a. To use GPIO_A0, write Bits[2:0] in Register 0x0040 to 0x6 and Bits[3:0] in Register 0x0041 to 0x0.
 - b. To use GPIO_B0, write Bits[5:3] in Register 0x0040 to 0x6 and Bits [7:4] in Register 0x0041 to 0x0.
2. Configure the NCO channel selector in GPIO level control mode by setting Bits[7:4] in the NCO control registers (Register 0x0314, Register 0x0334, Register 0x0354, and Register 0x0374) to 0x1 through 0x6, depending on the desired GPIO pin ordering.
3. Select the desired NCO channel through the GPIO pins.

GPIO Edge Control Mode

A low to high transition on a single GPIO pin determines the exact NCO channel selected. The internal channel selection counter is reset by either SYSREF± or the DDC soft reset.

The following procedure must be followed to use GPIO edge control for NCO channel selection:

1. Configure one or more GPIO pins as NCO channel selection inputs.
 - a. To use GPIO_A0, write Bits[2:0] in Register 0x0040 to 0x6 and Bits[3:0] in Register 0x0041 to 0x0.
 - b. To use GPIO_B0, write Bits[5:3] in Register 0x0040 to 0x6 and Bits[7:4] in Register 0x0041 to 0x0.

2. Configure the NCO channel selector in GPIO edge control mode by setting Bits[7:4] in the NCO control registers (Register 0x0314, Register 0x0334, Register 0x0354, and Register 0x0374) to 0x8 through 0xB, depending on the desired GPIO pin.
3. Configure the wrap point for the NCO channel selection by setting Bits[3:0] in the NCO control registers (Register 0x0314, Register 0x0334, Register 0x0354, and Register 0x0374). A value of 4 causes the channel selection to wrap at Channel 4 (0, 1, 2, 3, 4, 0, 1, 2, 3, 4, and so on).
4. Transition the selected GPIO pin from low to high to increment the NCO channel selection.

Register Map Mode

NCO channel selection is controlled directly through the register map.

Figure 115 shows an example use case for coherent mode using three NCO channels. In this example, NCO Channel 0 is actively downconverting Bandwidth 0 (B0), while NCO Channel 1 and Channel 2 are in standby mode and are tuned to Bandwidth 1 and Bandwidth 2 (B1 and B2), respectively.

The phase coherent NCO switching feature allows an infinite number of frequency hops that are all phase coherent. The initial phase of the NCO is established at time, t_0 , from SYSREF± synchronization. Switching the NCO FTW does not affect the phase. With this feature, only one FTW is required, but all 16 channels can be used to queue the next hop.

After SYSREF± synchronization at startup, all NCOs across multiple chips are inherently synchronized.

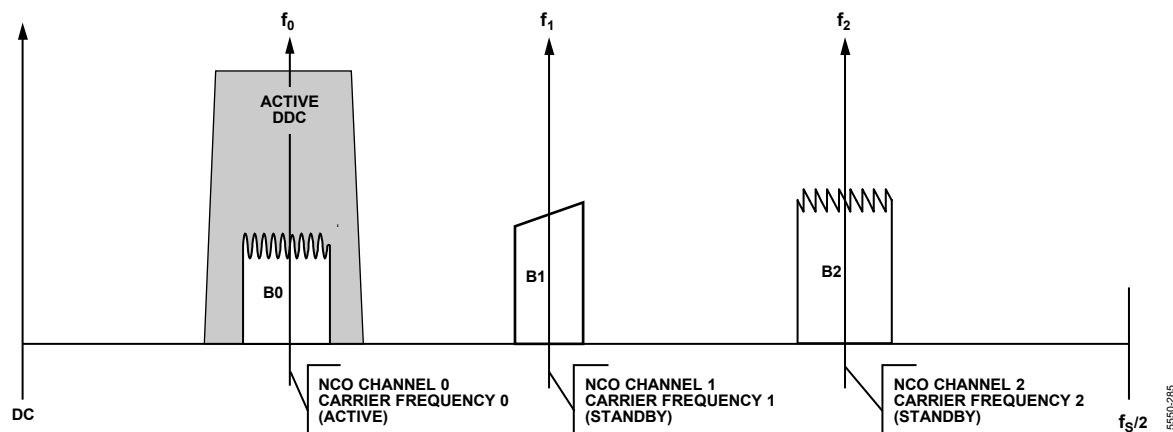

Figure 115. NCO Coherent Mode with Three NCO Channels (B0 Selected)

Setting Up the Multichannel NCO Feature

The first step to configure the multichannel NCO is to program the FTWs. The AD9689 memory map has an FTW index register for each DDC. This index determines which NCO channel receives the FTW from the register map. The following sequence describes the method for programming the FTWs:

1. Write the FTW index register with the desired DDC channel.
2. Write the FTW with the desired value. This value is applied to the NCO channel index mentioned in Step 1.
3. Repeat Step 1 and Step 2 for other NCO channels.

After setting the FTWs, the user must then select an active NCO channel. This selection can be performed either through the SPI registers or through the external GPIO pins. The following sequence describes the method for selecting the active NCO channel using the SPI:

1. Set the NCO channel select mode bits (Bits[7:4] in Register 0x0314, Register 0x0334, Register 0x0354, and Register 0x0374) to 0x0 to enable SPI selection.
2. Choose the active NCO channel using Bits[3:0] in Register 0x0314, Register 0x0334, Register 0x0354, and Register 0x0374.

The following sequence describes the method for selecting the active NCO channel using the GPIO CMOS pins:

1. Set the NCO channel select mode bits (Bits[7:4] in Register 0x0314, Register 0x0334, Register 0x0354, and Register 0x0374) to a nonzero value to enable GPIO pin selection.
2. Configure the GPIO pins as NCO channel selection inputs by writing to Register 0x0040, Register 0x0041, and Register 0x0042.
3. NCO switching is performed by externally controlling the GPIO CMOS pins.

NCO Synchronization

Each NCO contains a separate phase accumulator word (PAW). The initial reset value of each PAW is set to zero and incremented every clock cycle. The instantaneous phase of the NCO is calculated using the PAW, FTW, MAW, MBW, and POW. Due to this architecture, the FTW and POW registers can be updated at any time while still maintaining deterministic phase results in the PAW of the NCO.

Two methods can be used to synchronize multiple PAWs within the chip:

- Using the SPI. Use the DDC soft reset bit in the DDC synchronization control register (Register 0x0300, Bit 4) to reset all the PAWs in the chip. This reset is accomplished by setting the DDC soft reset bit high, and then setting this bit low. Note that this method can only be used to synchronize DDC channels within the same chip.
- Using the SYSREF± pin. When the SYSREF± pin is enabled in the SYSREF control registers (Register 0x0120 and Register 0x0121), and the DDC synchronization is enabled in the DDC synchronization control register (Register 0x0300, Bits[1:0]), any subsequent SYSREF± event resets all the PAWs in the chip. Note that this method can be used to synchronize DDC channels within the same chip or DDC channels within separate chips.

NCO Multichip Synchronization

In some applications, it is necessary to synchronize all the NCOs and local multiframe clocks (LMFCs) within multiple devices in a system. For applications requiring multiple NCO tuning frequencies in the system, a designer is likely to need to generate a single SYSREF pulse at all devices simultaneously. For many systems, generating or receiving a single-shot SYSREF pulse at all devices is challenging because of the following factors:

- Enabling or disabling the SYSREF pulse is often an asynchronous event.
- Not all clock generation chips support this feature.

For these reasons, the AD9689 contains a synchronization triggering mechanism that allows the following:

- Multichip synchronization of all NCOs and LMFCs at system startup.
- Multichip synchronization of all NCOs after applying new tuning frequencies during normal operation.

The synchronization triggering mechanism uses a master/slave arrangement, as shown in Figure 116.

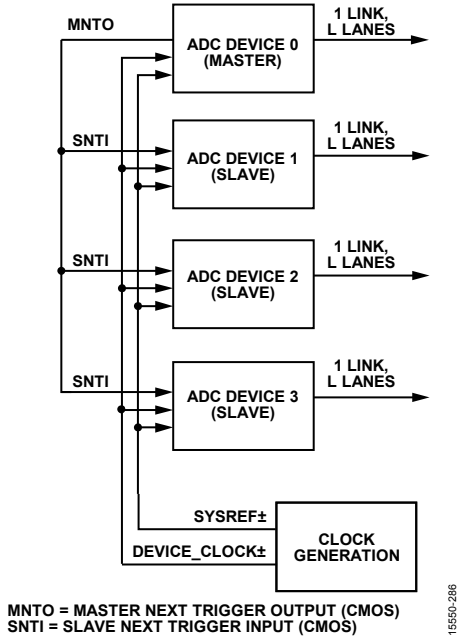

Figure 116. System Using Master/Slave Synchronization Triggering

Each device has an internal next synchronization trigger enable (NSTE) signal that controls whether the next SYSREF signal causes a synchronization event. Slave ADC devices must source their NSTE from an external slave next trigger input (SNTI) pin. Master devices can either use an external master next trigger output (MNTO) pin (default setting), or use an external SNTI pin.

See Table 47 (Register 0x0041 and Register 0x0042) to configure the FD_x/GPIO pins for this operation.

NCO Multichip Synchronization at Startup

Figure 117 shows a timing diagram along with the required sequence of events for NCO multichip synchronization using triggering and SYSREF at startup. Using this start-up sequence synchronizes all the NCOs and LMFCs in the system at once.

NCO Multichip Synchronization During Normal Operation

See the Setting Up the Multichannel NCO Feature section.

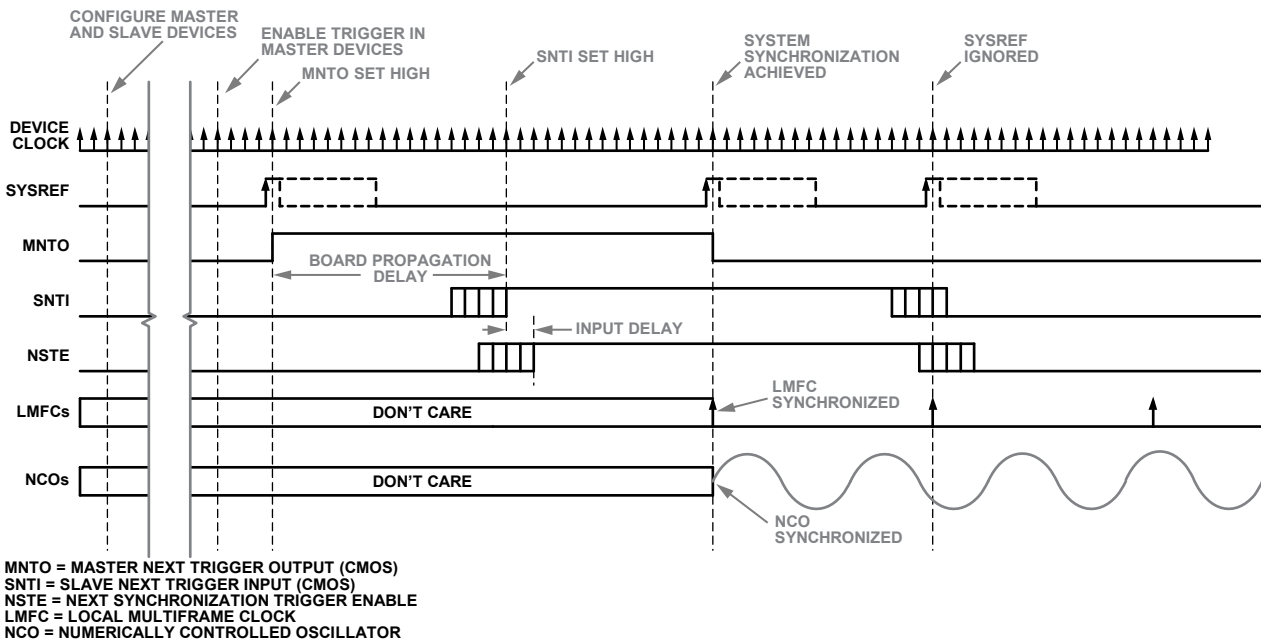

Figure 117. NCO Multichip Synchronization at Startup (Using Triggering and SYSREF)

DDC Mixer Description

When not bypassed (Register 0x0200 ≠ 0x00), the digital quadrature mixer performs a similar operation to an analog quadrature mixer. It performs the downconversion of input signals (real or complex) by using the NCO frequency as a local oscillator. For real input signals, a real mixer operation (with two multipliers) is performed. For complex input signals, a complex mixer operation (with four multipliers and two adders) is performed. The selection of real or complex inputs can be controlled individually for each DDC block using Bit 7 of the DDC control registers (Register 0x0310, Register 0x0330, Register 0x0350, and Register 0x0370).

DDC NCO + Mixer Loss and SFDR

When mixing a real input signal down to baseband, -6 dB of loss is introduced in the signal due to filtering of the negative image. An additional -0.05 dB of loss is introduced by the NCO. The total loss of a real input signal mixed down to baseband is -6.05 dB. For this reason, it is recommended that the user compensate for this loss by enabling the 6 dB of gain in the gain stage of the DDC to recenter the dynamic range of the signal within the full scale of the output bits (see the DDC Gain Stage (Optional) section).

When mixing a complex input signal (where I and Q DDC inputs come from the different ADCs) down to baseband, the maximum value each I/Q sample is able to reach is $1.414 \times$ full scale, after the sample passes through the complex mixer. To avoid overrange of the I/Q samples and to keep the data bit widths aligned with real mixing, -3.06 dB of loss is introduced in the mixer for complex signals. An additional -0.05 dB of loss is introduced by the NCO. The total loss of a complex input signal mixed down to baseband is -3.11 dB.

The worst case spurious signal from the NCO is greater than 102 dBc SFDR for all output frequencies.

DDC DECIMATION FILTERS

After the frequency translation stage, there are multiple decimation filter stages that reduce the output data rate. After the carrier of interest is tuned down to dc (carrier frequency = 0 Hz), these filters efficiently lower the sample rate, while providing sufficient alias rejection from unwanted adjacent carriers around the bandwidth of interest.

Figure 118 shows a simplified block diagram of the decimation filter stage, and Table 16 describes the filter characteristics of the different finite impulse response (FIR) filter blocks.

Table 17 shows the different filter configurations selectable by including different filters. In all cases, the DDC filtering stage provides 80% of the available output bandwidth, ± 0.005 dB of pass-band ripple and >100 dB of stop band alias rejection.

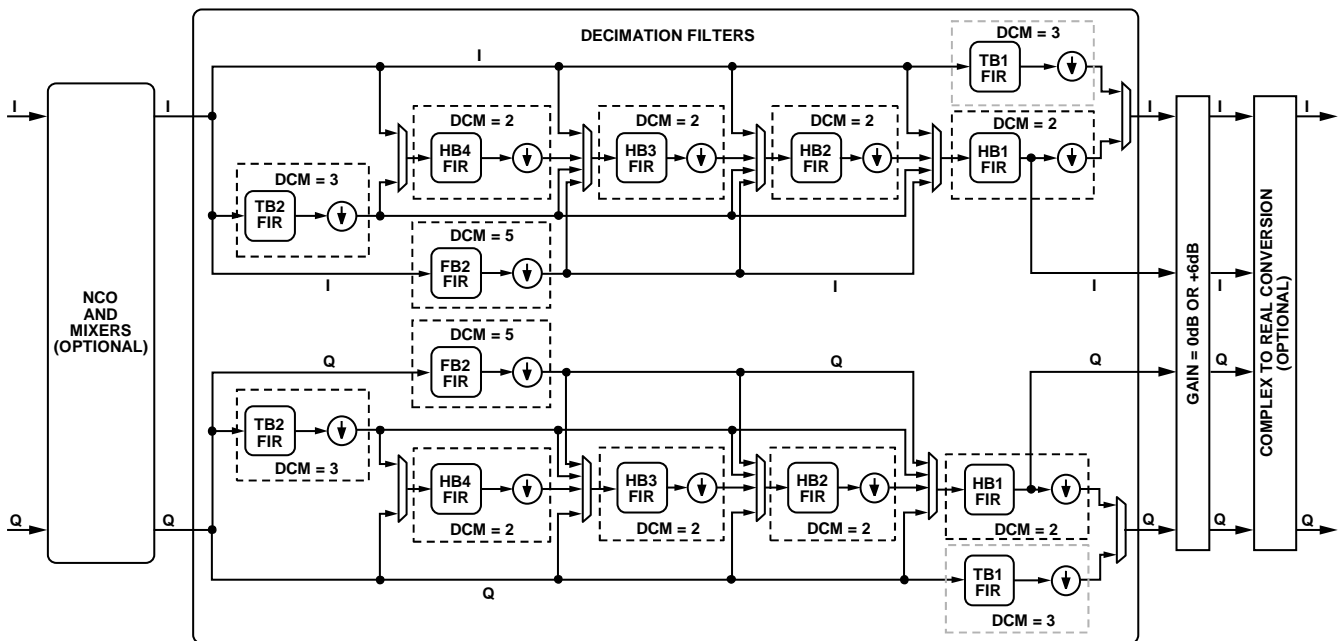

FIR = FINITE IMPULSE RESPONSE FILTER
DCM = DECIMATION

NOTES
1. TB1 IS ONLY SUPPORTED IN DDC0 AND DDC1

Figure 118. DDC Decimation Filter Block Diagram

15550-288

Table 16. DDC Decimation Filter Characteristics

Filter Name	Filter Type	Decimation Ratio	Pass Band (rad/sec)	Stop Band (rad/sec)	Pass-Band Ripple (dB)	Stop Band Attenuation (dB)
HB4	FIR low-pass	2	$0.1 \times \pi/2$	$1.9 \times \pi/2$	$<\pm 0.001$	>100
HB3	FIR low-pass	2	$0.2 \times \pi/2$	$1.8 \times \pi/2$	$<\pm 0.001$	>100
HB2	FIR low-pass	2	$0.4 \times \pi/2$	$1.6 \times \pi/2$	$<\pm 0.001$	>100
HB1	FIR low-pass	2	$0.8 \times \pi/2$	$1.2 \times \pi/2$	$<\pm 0.001$	>100
TB2	FIR low-pass	3	$0.4 \times \pi/3$	$1.6 \times \pi/3$	$<\pm 0.002$	>100
TB1 ¹	FIR low-pass	3	$0.8 \times \pi/3$	$1.2 \times \pi/3$	$<\pm 0.005$	>100
FB2	FIR low-pass	5	$0.4 \times \pi/5$	$1.6 \times \pi/5$	$<\pm 0.001$	>100

¹ TB1 is only supported in DDC0 and DDC1.

Table 17. DDC Filter Configurations¹

ADC Sample Rate	DDC Filter Configuration	Real (I) Output		Complex (I/Q) Outputs		Alias Protected Bandwidth	Ideal ² SNR Improvement (dB)
		Decimation Ratio	Sample Rate	Decimation Ratio	Sample Rate		
f _s	HB1	1	f _s	2	f _s /2 (I) + f _s /2 (Q)	f _s /2 × 80%	1
	TB1 ³	N/A	N/A	3	f _s /3 (I) + f _s /3 (Q)	f _s /3 × 80%	2.7
	HB2 + HB1	2	f _s /2	4	f _s /4 (I) + f _s /4 (Q)	f _s /4 × 80%	4
	TB2 + HB1	3	f _s /3	6	f _s /6 (I) + f _s /6 (Q)	f _s /6 × 80%	5.7
	HB3 + HB2 + HB1	4	f _s /4	8	f _s /8 (I) + f _s /8 (Q)	f _s /8 × 80%	7
	FB2 + HB1	5	f _s /5	10	f _s /10 (I) + f _s /10 (Q)	f _s /10 × 80%	8
	TB2 + HB2 + HB1	6	f _s /6	12	f _s /12 (I) + f _s /12 (Q)	f _s /12 × 80%	8.8
	FB2 + TB1 ³	N/A	N/A	15	f _s /15 (I) + f _s /15 (Q)	f _s /15 × 80%	9.7
	HB4 + HB3 + HB2 + HB1	8	f _s /8	16	f _s /16 (I) + f _s /16 (Q)	f _s /16 × 80%	10
	FB2 + HB2 + HB1	10	f _s /10	20	f _s /20 (I) + f _s /20 (Q)	f _s /20 × 80%	11
	TB2 + HB3 + HB2 + HB1	12	f _s /12	24	f _s /24 (I) + f _s /24 (Q)	f _s /24 × 80%	11.8
	HB2 + FB2 + TB1 ³	N/A	N/A	30	f _s /30 (I) + f _s /30 (Q)	f _s /30 × 80%	12.7
	FB2 + HB3 + HB2 + HB1	20	f _s /20	40	f _s /40 (I) + f _s /40 (Q)	f _s /40 × 80%	14
	TB2 + HB4 + HB3 + HB2 + HB1	24	f _s /24	48	f _s /48 (I) + f _s /48 (Q)	f _s /48 × 80%	14.8

¹ N/A means not applicable.

² Ideal SNR improvement due to oversampling + filtering = $10\log(\text{bandwidth}/f_s/2)$.

³ TB1 is only supported in DDC0 and DDC1.

HB4 Filter Description

The first decimate by 2, half-band, low-pass, FIR filter (HB4) uses an 11-tap, symmetrical, fixed coefficient filter implementation that is optimized for low power consumption. The HB4 filter is only used when complex outputs (decimate by 16) or real outputs (decimate by 8) are enabled; otherwise, it is bypassed. Table 18 and Figure 119 show the coefficients and response of the HB4 filter.

Table 18. HB4 Filter Coefficients

HB4 Coefficient Number	Normalized Coefficient	Decimal Coefficient (15-Bit)
C1, C11	0.006042	99
C2, C10	0	0
C3, C9	-0.049377	-809
C4, C8	0	0
C5, C7	0.293335	4806
C6	0.5	8192

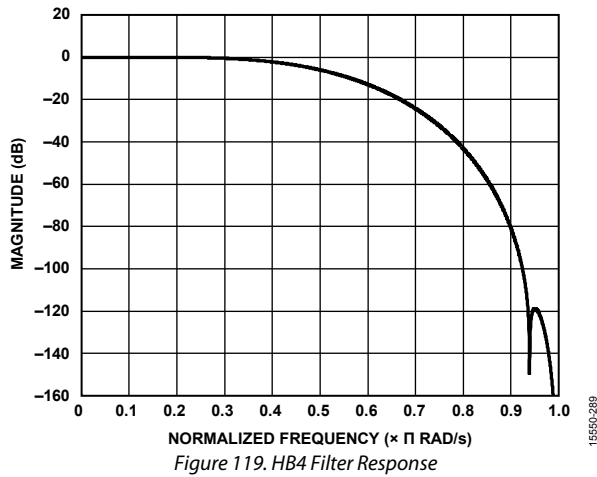

HB3 Filter Description

The second decimate by 2, half-band, low-pass, FIR filter (HB3) uses an 11-tap, symmetrical, fixed coefficient filter implementation that is optimized for low power consumption. The HB3 filter is only used when complex outputs (decimate by 8 or 16) or real outputs (decimate by 4 or 8) are enabled; otherwise, it is bypassed. Table 19 and Figure 120 show the coefficients and response of the HB3 filter.

Table 19. HB3 Filter Coefficients

HB3 Coefficient Number	Normalized Coefficient	Decimal Coefficient (17-Bit)
C1, C11	0.006638	435
C2, C10	0	0
C3, C9	-0.051056	-3346
C4, C8	0	0
C5, C7	0.294418	19295
C6	0.500000	32768

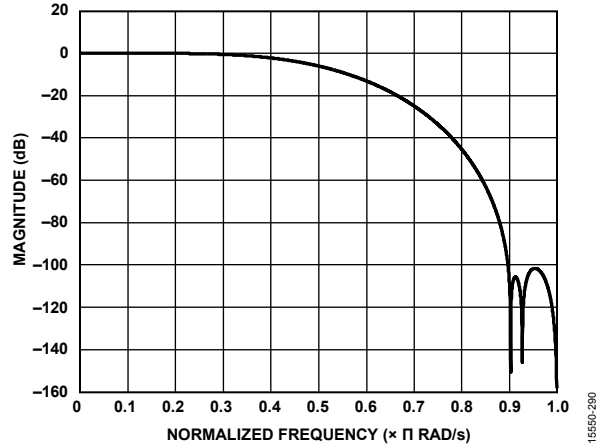

HB2 Filter Description

The third decimate by 2, half-band, low-pass, FIR filter (HB2) uses a 19-tap, symmetrical, fixed coefficient filter implementation that is optimized for low power consumption.

The HB2 filter is only used when complex or real outputs (decimate by 4, 8, or 16) are enabled; otherwise, it is bypassed.

Table 20 and Figure 121 show the coefficients and response of the HB2 filter.

Table 20. HB2 Filter Coefficients

HB2 Coefficient Number	Normalized Coefficient	Decimal Coefficient (18-Bit)
C1, C19	0.000671	88
C2, C18	0	0
C3, C17	-0.005325	-698
C4, C16	0	0
C5, C15	0.022743	2981
C6, C14	0	0
C7, C13	-0.074181	-9723
C8, C12	0	0
C9, C11	0.306091	40120
C10	0.5	65536

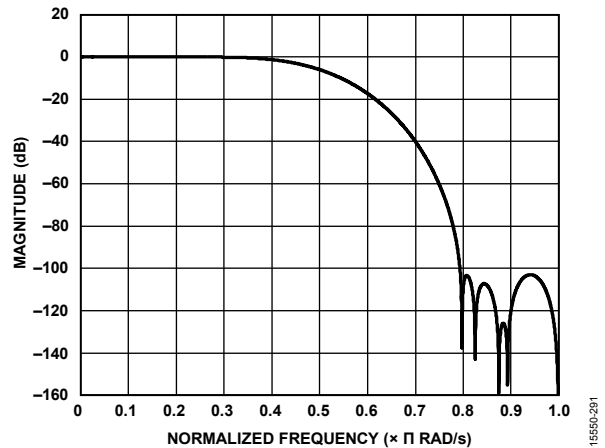

HB1 Filter Description

The fourth and final decimate by 2, half-band, low-pass, FIR filter (HB1) uses a 63-tap, symmetrical, fixed coefficient filter implementation that is optimized for low power consumption. The HB1 filter is always enabled and cannot be bypassed. Table 21 and Figure 122 show the coefficients and response of the HB1 filter.

Table 21. HB1 Filter Coefficients

HB1 Coefficient Number	Normalized Coefficient	Decimal Coefficient (20-Bit)
C1, C63	-0.000019	-10
C2, C62	0	0
C3, C61	0.000072	38
C4, C60	0	0
C5, C59	-0.000195	-102
C6, C58	0	0
C7, C57	0.000443	232
C8, C56	0	0
C9, C55	-0.000891	-467
C10, C54	0	0
C11, C53	0.001644	862
C12, C52	0	0
C13, C51	-0.002840	-1489
C14, C50	0	0
C15, C49	0.004654	2440
C16, C48	0	0
C17, C47	-0.007311	-3833
C18, C46	0	0
C19, C45	0.011122	5831
C20, C44	0	0
C21, C43	-0.016554	-8679
C22, C42	0	0
C23, C41	0.024420	12803
C24, C40	0	0
C25, C39	-0.036404	-19086
C26, C38	0	0
C27, C37	0.056866	29814
C28, C36	0	0
C29, C35	-0.101892	-53421
C30, C34	0	0
C31, C33	0.316883	166138
C32	0.5	262144

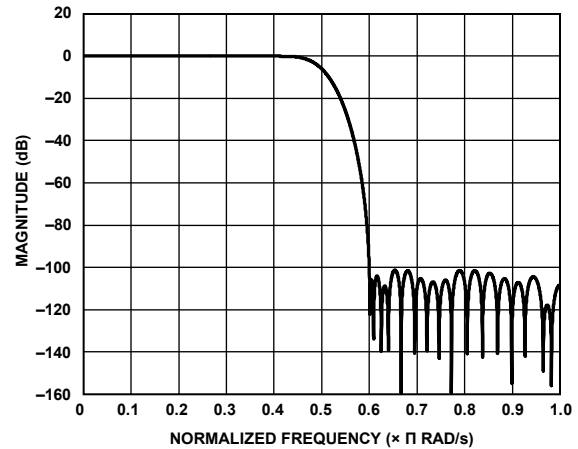

Figure 122. HB1 Filter Response

TB2 Filter Description

The TB2 filter uses a 26-tap, symmetrical, fixed coefficient filter implementation that is optimized for low power consumption. The TB2 filter is only used when decimation ratios of 6, 12, or 24 are required. Table 22 and Figure 123 show the coefficients and response of the TB2 filter.

Table 22. TB2 Filter Coefficients

TB2 Coefficient Number	Normalized Coefficient	Decimal Coefficient (19-Bit)
C1, C26	-0.000191	-50
C2, C25	-0.000793	-208
C3, C24	-0.001137	-298
C4, C23	0.000916	240
C5, C22	0.006290	1649
C6, C21	0.009823	2575
C7, C20	0.000916	240
C8, C19	-0.023483	-6156
C9, C18	-0.043152	-11312
C10, C17	-0.019318	-5064
C11, C16	0.071327	18698
C12, C15	0.201172	52736
C13, C14	0.297756	78055

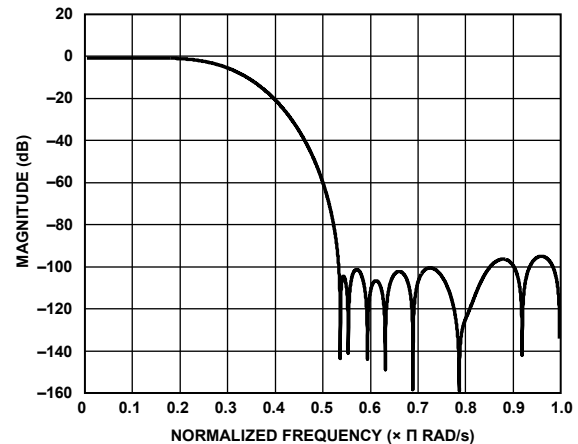

Figure 123. TB2 Filter Response

TB1 Filter Description

The TB1 decimate by 3, low-pass, FIR filter uses a 76-tap, symmetrical, fixed coefficient filter implementation. Table 23 shows the TB1 filter coefficients, and Figure 124 shows the TB1 filter response. TB1 is only supported in DDC0 and DDC1.

Table 23. TB1 Filter Coefficients

TB1 Coefficient Number	Normalized Coefficient	Decimal Coefficient (22-Bit)
1, 96	-0.000023	-96
2, 75	-0.000053	-224
3, 74	-0.000037	-156
4, 73	0.000090	379
5, 72	0.000291	1220
6, 71	0.000366	1534
7, 70	0.000095	398
8, 69	-0.000463	-1940
9, 68	-0.000822	-3448
10, 67	-0.000412	-1729
11, 66	0.000739	3100
12, 65	0.001665	6984
13, 64	0.001132	4748
14, 63	-0.000981	-4114
15, 62	-0.002961	-12418
16, 61	-0.002438	-10226
17, 60	0.001087	4560
18, 59	0.004833	20272
19, 58	0.004614	19352
20, 57	-0.000871	-3652
21, 56	-0.007410	-31080
22, 55	-0.008039	-33718
23, 54	0.000053	222
24, 53	0.010874	45608
25, 52	0.013313	55840
26, 51	0.001817	7620
27, 50	-0.015579	-65344
28, 49	-0.021590	-90556
29, 48	-0.005603	-23502
30, 47	0.022451	94167
31, 46	0.035774	150046
32, 45	0.013541	56796
33, 44	-0.034655	-145352
34, 43	-0.066549	-279128
35, 42	-0.035213	-147694
36, 41	0.071220	298720
37, 40	0.210777	884064
38, 39	0.309200	1296880

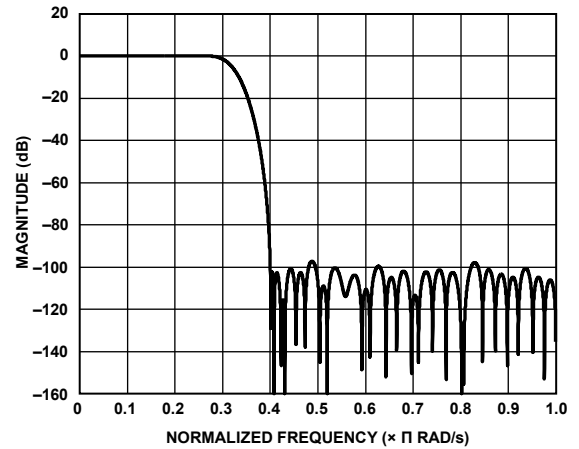

Figure 124. TB1 Filter Response

15550-234

FB2 Filter Description

The FB2 decimate by 5, low-pass, FIR filter uses a 48-tap, symmetrical, fixed coefficient filter implementation. Table 24 shows the FB2 filter coefficients, and Figure 125 shows the FB2 filter response.

Table 24. FB2 Filter Coefficients

FB2 Coefficient Number	Normalized Coefficient	Decimal Coefficient (21-Bit)
1, 48	0.000007	7
2, 47	-0.000004	-4
3, 46	-0.000069	-72
4, 45	-0.000244	-256
5, 44	-0.000544	-570
6, 43	-0.000870	-912
7, 42	-0.000962	-1009
8, 41	-0.000448	-470
9, 40	0.000977	1024
10, 39	0.003237	3394
11, 38	0.005614	5887
12, 37	0.006714	7040
13, 36	0.004871	5108
14, 35	-0.001011	-1060
15, 34	-0.010456	-10964
16, 33	-0.020729	-21736
17, 32	-0.026978	-28288
18, 31	-0.023453	-24592
19, 30	-0.005608	-5880
20, 29	0.027681	29026
21, 28	0.072720	76252
22, 27	0.121223	127112
23, 26	0.162346	170232
24, 25	0.185959	194992

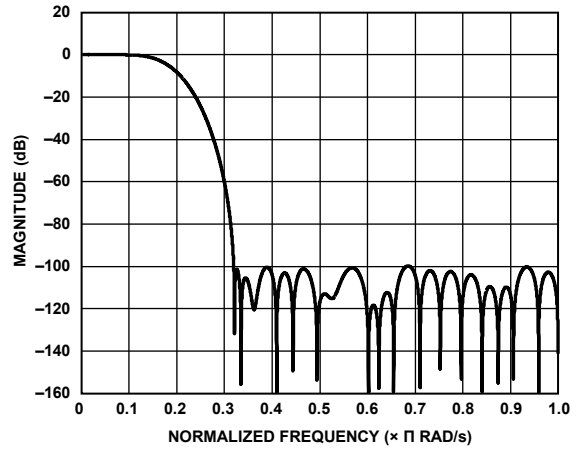

Figure 125. FB2 Filter Response

DDC GAIN STAGE

Each DDC contains an independently controlled gain stage. The gain is selectable as either 0 dB or 6 dB. When mixing a real input signal down to baseband, it is recommended that the user enable the 6 dB of gain to recenter the dynamic range of the signal within the full scale of the output bits.

When mixing a complex input signal down to baseband, the mixer has already recentered the dynamic range of the signal within the full scale of the output bits, and no additional gain is necessary. However, the optional 6 dB gain compensates for low signal strengths. The downsample by 2 portion of the HB1 FIR filter is bypassed when using the complex to real conversion stage. The TB1 filter does not have the 6 dB gain stage.

DDC COMPLEX TO REAL CONVERSION

Each DDC contains an independently controlled complex to real conversion block. The complex to real conversion block reuses the last filter (HB1 FIR) in the filtering stage along with an $f_s/4$ complex mixer to upconvert the signal. After upconverting the signal, the Q portion of the complex mixer is no longer needed and is dropped. The TB1 filter does not support complex to real conversion.

Figure 126 shows a simplified block diagram of the complex to real conversion.

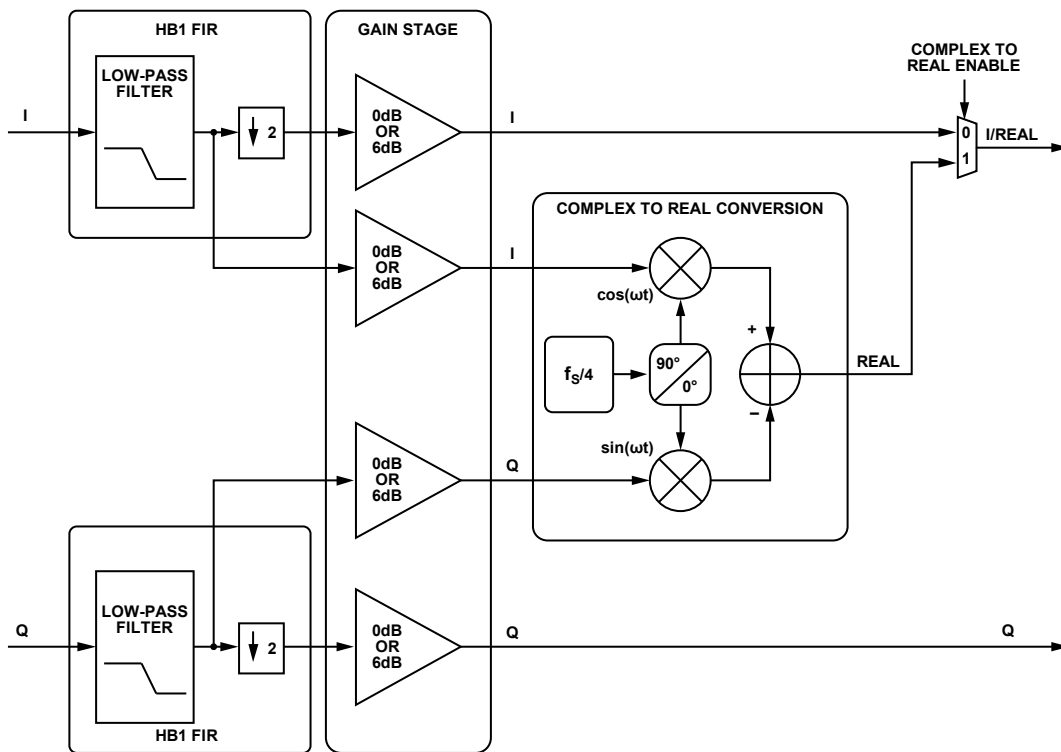

Figure 126. Complex to Real Conversion Block

15560-057

DDC MIXED DECIMATION SETTINGS

The AD9689 also supports DDCs with different decimation rates. In this scenario, the chip decimation ratio must be set to the lowest decimation ratio of all the DDC channels. Samples of higher decimation ratio DDCs are repeated to match the chip decimation ratio sample rate. Only mixed decimation ratios that are integer multiples of 2 are supported. For example, decimate by 1, 2, 4, 8, or 16 can be mixed together; decimate by 3, 6, 12, 24, or 48 can be mixed together; or decimate by 5, 10, 20, or 40 can be mixed together.

Table 25 shows the DDC sample mapping when the chip decimation ratio is different than the DDC decimation ratio.

For example, if the chip decimation ratio is set to decimate by 4, DDC0 is set to use the HB2 + HB1 filters (complex outputs are decimate by 4) and DDC1 is set to use the HB4 + HB3 + HB2 + HB1 filters (real outputs are decimate by 8), then DDC1 repeats its output data two times for every one DDC0 output. The resulting output samples are shown in Table 26.

Table 25. Sample Mapping When the Chip Decimation Ratio (DCM) Does Not Match DDC DCM

Sample Index	DDC DCM = Chip DCM	DDC DCM = 2 × Chip DCM	DDC DCM = 4 × Chip DCM	DDC DCM = 8 × Chip DCM
0	N	N	N	N
1	N + 1	N	N	N
2	N + 2	N + 1	N	N
3	N + 3	N + 1	N	N
4	N + 4	N + 2	N + 1	N
5	N + 5	N + 2	N + 1	N
6	N + 6	N + 3	N + 1	N
7	N + 7	N + 3	N + 1	N
8	N + 8	N + 4	N + 2	N + 1
9	N + 9	N + 4	N + 2	N + 1
10	N + 10	N + 5	N + 2	N + 1
11	N + 11	N + 5	N + 2	N + 1
12	N + 12	N + 6	N + 3	N + 1
13	N + 13	N + 6	N + 3	N + 1
14	N + 14	N + 7	N + 3	N + 1
15	N + 15	N + 7	N + 3	N + 1
16	N + 16	N + 8	N + 4	N + 2
17	N + 17	N + 8	N + 4	N + 2
18	N + 18	N + 9	N + 4	N + 2
19	N + 19	N + 9	N + 4	N + 2
20	N + 20	N + 10	N + 5	N + 2
21	N + 21	N + 10	N + 5	N + 2
22	N + 22	N + 11	N + 5	N + 2
23	N + 23	N + 11	N + 5	N + 2
24	N + 24	N + 12	N + 6	N + 3
25	N + 25	N + 12	N + 6	N + 3
26	N + 26	N + 13	N + 6	N + 3
27	N + 27	N + 13	N + 6	N + 3
28	N + 28	N + 14	N + 7	N + 3
29	N + 29	N + 14	N + 7	N + 3
30	N + 30	N + 15	N + 7	N + 3
31	N + 31	N + 15	N + 7	N + 3

Table 26. Chip DCM = 4, DDC0 DCM = 4 (Complex), and DDC1 DCM = 8 (Real)¹

DDC Input Samples	DDC0		DDC1	
	Output Port I	Output Port Q	Output Port I	Output Port Q
N	I0[N]	Q0[N]	I1[N]	Not applicable
N + 1	I0[N]	Q0[N]	I1[N]	Not applicable
N + 2	I0[N]	Q0[N]	I1[N]	Not applicable
N + 3	I0[N]	Q0[N]	I1[N]	Not applicable
N + 4	I0[N + 1]	Q0[N + 1]	I1[N]	Not applicable
N + 5	I0[N + 1]	Q0[N + 1]	I1[N]	Not applicable
N + 6	I0[N + 1]	Q0[N + 1]	I1[N]	Not applicable
N + 7	I0[N + 1]	Q0[N + 1]	I1[N]	Not applicable
N + 8	I0[N + 2]	Q0[N + 2]	I1[N + 1]	Not applicable
N + 9	I0[N + 2]	Q0[N + 2]	I1[N + 1]	Not applicable
N + 10	I0[N + 2]	Q0[N + 2]	I1[N + 1]	Not applicable
N + 11	I0[N + 2]	Q0[N + 2]	I1[N + 1]	Not applicable
N + 12	I0[N + 3]	Q0[N + 3]	I1[N + 1]	Not applicable
N + 13	I0[N + 3]	Q0[N + 3]	I1[N + 1]	Not applicable
N + 14	I0[N + 3]	Q0[N + 3]	I1[N + 1]	Not applicable
N + 15	I0[N + 3]	Q0[N + 3]	I1[N + 1]	Not applicable

¹ DCM means decimation.

DDC EXAMPLE CONFIGURATIONS

Table 27 describes the register settings for multiple DDC example configurations.

Table 27. DDC Example Configurations (Per ADC Channel Pair)

Chip Application Layer	Chip Decimation Ratio	DDC Input Type	DDC Output Type	Bandwidth Per DDC ¹	No. of Virtual Converters Required	Register Settings
One DDC	2	Complex	Complex	$40\% \times f_s$	2	0x0200 = 0x01 (one DDC; I/Q selected) 0x0201 = 0x01 (chip decimate by 2) 0x0310 = 0x83 (complex mixer; 0 dB gain; variable IF; complex outputs; HB1 filter) 0x0311 = 0x04 (DDC I Input = ADC Channel A; DDC Q input = ADC Channel B) 0x0316, 0x0317, 0x0318, 0x0319, 0x031A, 0x031B, 0x031D, 0x031E, 0x031F, 0x0320, 0x0321, 0x0322 = FTW and POW set as required by application for DDC0
Two DDCs	4	Complex	Complex	$20\% \times f_s$	4	0x0200 = 0x02 (two DDCs; I/Q selected) 0x0201 = 0x02 (chip decimate by 4) 0x0310, 0x0330 = 0x80 (complex mixer; 0 dB gain; variable IF; complex outputs; HB2 + HB1 filters) 0x0311, 0x0331 = 0x04 (DDC I input = ADC Channel A; DDC Q input = ADC Channel B) 0x0316, 0x0317, 0x0318, 0x0319, 0x031A, 0x031B, 0x031D, 0x031E, 0x031F, 0x0320, 0x0321, 0x0322 = FTW and POW set as required by application for DDC0 0x0336, 0x0337, 0x0338, 0x0339, 0x033A, 0x033B, 0x033D, 0x033E, 0x033F, 0x0340, 0x0341, 0x0342 = FTW and POW set as required by application for DDC1
Two DDCs	4	Complex	Real	$10\% \times f_s$	2	0x0200 = 0x22 (two DDCs; I only selected) 0x0201 = 0x02 (chip decimate by 4) 0x0310, 0x0330 = 0x89 (complex mixer; 0 dB gain; variable IF; real output; HB3 + HB2 + HB1 filters) 0x0311, 0x0331 = 0x04 (DDC I Input = ADC Channel A; DDC Q input = ADC Channel B) 0x0316, 0x0317, 0x0318, 0x0319, 0x031A, 0x031B, 0x031D, 0x031E, 0x031F, 0x0320, 0x0321, 0x0322 = FTW and POW set as required by application for DDC0 0x0336, 0x0337, 0x0338, 0x0339, 0x033A, 0x033B, 0x033D, 0x033E, 0x033F, 0x0340, 0x0341, 0x0342 = FTW and POW set as required by application for DDC1
Two DDCs	4	Real	Real	$10\% \times f_s$	2	0x0200 = 0x22 (two DDCs; I only selected) 0x0201 = 0x02 (chip decimate by 4) 0x0310, 0x0330 = 0x49 (real mixer; 6 dB gain; variable IF; real output; HB3 + HB2 + HB1 filters) 0x0311 = 0x00 (DDC0 I input = ADC Channel A; DDC0 Q input = ADC Channel A) 0x0331 = 0x05 (DDC1 I input = ADC Channel B; DDC1 Q input = ADC Channel B) 0x0316, 0x0317, 0x0318, 0x0319, 0x031A, 0x031B, 0x031D, 0x031E, 0x031F, 0x0320, 0x0321, 0x0322 = FTW and POW set as required by application for DDC0 0x0336, 0x0337, 0x0338, 0x0339, 0x033A, 0x033B, 0x033D, 0x033E, 0x033F, 0x0340, 0x0341, 0x0342 = FTW and POW set as required by application for DDC1

Chip Application Layer	Chip Decimation Ratio	DDC Input Type	DDC Output Type	Bandwidth Per DDC ¹	No. of Virtual Converters Required	Register Settings
Two DDCs	4	Real	Complex	$20\% \times f_s$	4	<p>0x0200 = 0x02 (two DDCs; I/Q selected) 0x0201 = 0x02 (chip decimate by 4) 0x0310, 0x0330 = 0x40 (real mixer; 6 dB gain; variable IF; complex output; HB2 + HB1 filters) 0x0311 = 0x00 (DDC0 I input = ADC Channel A; DDC0 Q input = ADC Channel A) 0x0331 = 0x05 (DDC1 I input = ADC Channel B; DDC1 Q input = ADC Channel B) 0x0316, 0x0317, 0x0318, 0x0319, 0x031A, 0x031B, 0x031D, 0x031E, 0x031F, 0x0320, 0x0321, 0x0322 = FTW and POW set as required by application for DDC0 0x0336, 0x0337, 0x0338, 0x0339, 0x033A, 0x033B, 0x033D, 0x033E, 0x033F, 0x0340, 0x0341, 0x0342 = FTW and POW set as required by application for DDC1</p>
Two DDCs	8	Real	Real	$5\% \times f_s$	2	<p>0x0200 = 0x22 (two DDCs; I only selected) 0x0201 = 0x03 (chip decimate by 8) 0x0310, 0x0330 = 0x4A (real mixer; 6 dB gain; variable IF; real output; HB4 + HB3 + HB2 + HB1 filters) 0x0311 = 0x00 (DDC0 I input = ADC Channel A; DDC0 Q input = ADC Channel A) 0x0331 = 0x05 (DDC1 I input = ADC Channel B; DDC1 Q input = ADC Channel B) 0x0316, 0x0317, 0x0318, 0x0319, 0x031A, 0x031B, 0x031D, 0x031E, 0x031F, 0x0320, 0x0321, 0x0322 = FTW and POW set as required by application for DDC0 0x0336, 0x0337, 0x0338, 0x0339, 0x033A, 0x033B, 0x033D, 0x033E, 0x033F, 0x0340, 0x0341, 0x0342 = FTW and POW set as required by application for DDC1</p>
Four DDCs	8	Real	Complex	$10\% \times f_s$	8	<p>0x0200 = 0x03 (four DDCs; I/Q selected) 0x0201 = 0x03 (chip decimate by 8) 0x0310, 0x0330, 0x0350, 0x0370 = 0x41 (real mixer; 6 dB gain; variable IF; complex output; HB3 + HB2 + HB1 filters) 0x0311 = 0x00 (DDC0 I input = ADC Channel A; DDC0 Q input = ADC Channel A) 0x0331 = 0x00 (DDC1 I input = ADC Channel A; DDC1 Q input = ADC Channel A) 0x0351 = 0x05 (DDC2 I input = ADC Channel B; DDC2 Q input = ADC Channel B) 0x0371 = 0x05 (DDC3 I input = ADC Channel B; DDC3 Q input = ADC Channel B) 0x0316, 0x0317, 0x0318, 0x0319, 0x031A, 0x031B, 0x031D, 0x031E, 0x031F, 0x0320, 0x0321, 0x0322 = FTW and POW set as required by application for DDC0 0x0336, 0x0337, 0x0338, 0x0339, 0x033A, 0x033B, 0x033D, 0x033E, 0x033F, 0x0340, 0x0341, 0x0342 = FTW and POW set as required by application for DDC1 0x0356, 0x0357, 0x0358, 0x0359, 0x035A, 0x035B, 0x035D, 0x035E, 0x035F, 0x0360, 0x0361, 0x0362 = FTW and POW set as required by application for DDC2 0x0376, 0x0377, 0x0378, 0x0379, 0x037A, 0x037B, 0x037D, 0x037E, 0x037F, 0x0380, 0x0381, 0x0382 = FTW and POW set as required by application for DDC3</p>

Chip Application Layer	Chip Decimation Ratio	DDC Input Type	DDC Output Type	Bandwidth Per DDC ¹	No. of Virtual Converters Required	Register Settings
Four DDCs	8	Real	Real	$5\% \times f_s$	4	<p>0x0200 = 0x23 (four DDCs; I only selected) 0x0201 = 0x03 (chip decimate by 8) 0x0310, 0x0330, 0x0350, 0x0370 = 0x4A (real mixer; 6 dB gain; variable IF; real output; HB4 + HB3 + HB2 + HB1 filters) 0x0311 = 0x00 (DDC0 I input = ADC Channel A; DDC0 Q input = ADC Channel A) 0x0331 = 0x00 (DDC1 I input = ADC Channel A; DDC1 Q input = ADC Channel A) 0x0351 = 0x05 (DDC2 I input = ADC Channel B; DDC2 Q input = ADC Channel B) 0x0371 = 0x05 (DDC3 I input = ADC Channel B; DDC3 Q input = ADC Channel B) 0x0316, 0x0317, 0x0318, 0x0319, 0x031A, 0x031B, 0x031D, 0x031E, 0x031F, 0x0320, 0x0321, 0x0322 = FTW and POW set as required by application for DDC0 0x0336, 0x0337, 0x0338, 0x0339, 0x033A, 0x033B, 0x033D, 0x033E, 0x033F, 0x0340, 0x0341, 0x0342 = FTW and POW set as required by application for DDC1 0x0356, 0x0357, 0x0358, 0x0359, 0x035A, 0x035B, 0x035D, 0x035E, 0x035F, 0x0360, 0x0361, 0x0362 = FTW and POW set as required by application for DDC2 0x0376, 0x0377, 0x0378, 0x0379, 0x037A, 0x037B, 0x037D, 0x037E, 0x037F, 0x0380, 0x0381, 0x0382 = FTW and POW set as required by application for DDC3</p>
Four DDCs	16	Real	Complex	$5\% \times f_s$	8	<p>0x0200 = 0x03 (four DDCs; I/Q selected) 0x0201 = 0x04 (chip decimate by 16) 0x0310, 0x0330, 0x0350, 0x0370 = 0x42 (real mixer; 6 dB gain; variable IF; complex output; HB4 + HB3 + HB2 + HB1 filters) 0x0311 = 0x00 (DDC0 I input = ADC Channel A; DDC0 Q input = ADC Channel A) 0x0331 = 0x00 (DDC1 I input = ADC Channel A; DDC1 Q input = ADC Channel A) 0x0351 = 0x05 (DDC2 I input = ADC Channel B; DDC2 Q input = ADC Channel B) 0x0371 = 0x05 (DDC3 I input = ADC Channel B; DDC3 Q input = ADC Channel B) 0x0316, 0x0317, 0x0318, 0x0319, 0x031A, 0x031B, 0x031D, 0x031E, 0x031F, 0x0320, 0x0321, 0x0322 = FTW and POW set as required by application for DDC0 0x0336, 0x0337, 0x0338, 0x0339, 0x033A, 0x033B, 0x033D, 0x033E, 0x033F, 0x0340, 0x0341, 0x0342 = FTW and POW set as required by application for DDC1 0x0356, 0x0357, 0x0358, 0x0359, 0x035A, 0x035B, 0x035D, 0x035E, 0x035F, 0x0360, 0x0361, 0x0362 = FTW and POW set as required by application for DDC2 0x0376, 0x0377, 0x0378, 0x0379, 0x037A, 0x037B, 0x037D, 0x037E, 0x037F, 0x0380, 0x0381, 0x0382 = FTW and POW set as required by application for DDC3</p>

¹ f_s is the ADC sample rate.

DDC POWER CONSUMPTION

Table 28 and Figure 28 describe the typical and maximum DVDD and DRVDD1 power consumption for certain DDC modes for 2.0 GSPS and 2.6 GSPS.

Table 28. DDC Power Consumption for Example Configurations for 2.0 GSPS; $f_s = 2.0$ GHz

Number of DDCs	DDC Decimation Ratio ¹	Number of Lanes (L)	Number of Virtual Converters (M)	Number of Octets per frame (F)	DVDD Power (mW)		DRVDD1 Power (mW)	
					Typ	Max	Typ	Max
2	3	8	4	2	465	958	240	345
2	4	8	4	1	400	877	200	301
2	6	4	4	2	405	881	135	226
2	8	4	4	2	385	858	115	205
2	12	2	4	4	400	870	80	170
4	6	8	8	2	525	1040	240	345
4	8	8	8	2	485	970	200	295

¹ See Table 17 for details on decimation filter selection, the associated alias protected bandwidths, and SNR improvements.

Table 29. DDC Power Consumption for Example Configurations for 2.6 GSPS; $f_s = 2.56$ GHz

Number of DDCs	DDC Decimation Ratio ¹	Number of Lanes (L)	Number of Virtual Converters (M)	Number of Octets per frame (F)	DVDD Power (mW)		DRVDD1 Power (mW)	
					Typ	Max	Typ	Max
2	3	8	4	2	575	995	280	375
2	4	8	4	1	520	930	230	325
2	6	4	4	2	515	925	155	238
2	8	4	4	2	500	905	135	211
2	12	2	4	4	510	912	95	165
4	6	8	8	2	655	1090	280	380
4	8	8	8	2	630	1090	230	325

¹ See Table 17 for details on decimation filter selection, the associated alias protected bandwidths, and SNR improvements.

SIGNAL MONITOR

The signal monitor block provides additional information about the signal being digitized by the ADC. The signal monitor computes the peak magnitude of the digitized signal. This information can be used to drive an AGC loop to optimize the range of the ADC in the presence of real-world signals.

The results of the signal monitor block can be obtained either by reading back the internal values from the SPI port or by embedding the signal monitoring information into the JESD204B interface as separate control bits. A global, 24-bit programmable period controls the duration of the measurement. Figure 127 shows the simplified block diagram of the signal monitor block.

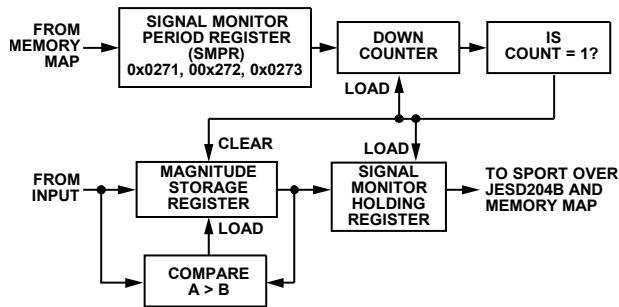

Figure 127. Signal Monitor Block

The peak detector captures the largest signal within the observation period. The detector only observes the magnitude of the signal. The resolution of the peak detector is a 13-bit value, and the observation period is 24 bits and represents converter output samples. The peak magnitude can be derived by using the following equation:

$$\text{Peak Magnitude (dBFS)} = 20\log(\text{Peak Detector Value}/2^{13})$$

The magnitude of the input port signal is monitored over a programmable time period, which is determined by the signal monitor period register (SMPR). The peak detector function is enabled by setting Bit 1 in the signal monitor control register (Register 0x0270). The 24-bit SMPR must be programmed before activating this mode.

After enabling peak detection mode, the value in the SMPR is loaded into a monitor period timer, which decrements at the decimated clock rate. The magnitude of the input signal is compared with the value in the internal magnitude storage register (not accessible to the user), and the greater of the two is updated as the current peak level. The initial value of the magnitude storage register is set to the current ADC input signal magnitude. This comparison continues until the monitor period timer reaches a count of 1.

When the monitor period timer reaches a count of 1, the 13-bit peak level value is transferred to the signal monitor holding register, which can be read through the memory map or output through the SPORT over the JESD204B interface. The monitor period timer is reloaded with the value in the SMPR, and the countdown restarts. In addition, the magnitude of the first input sample updates in the magnitude storage register, and the comparison and update procedure, as explained previously, continues.

SPORT OVER JESD204B

The signal monitor data can also be serialized and sent over the JESD204B interface as control bits. These control bits must be deserialized from the samples to reconstruct the statistical data. The signal control monitor function is enabled by setting Bits[1:0] of Register 0x0279 and Bit 1 of Register 0x027A. Figure 128 shows two different example configurations for the signal monitor control bit locations inside the JESD204B samples. A maximum of three control bits can be inserted into the JESD204B samples; however, only one control bit is required for the signal monitor. Control bits are inserted from MSB to LSB.

If only one control bit is to be inserted (CS = 1), only the most significant control bit is used (see Example Configuration 1 and Example Configuration 2 in Figure 128). To select the SPORT over JESD204B option, program Register 0x0559, Register 0x055A, and Register 0x058F. See Table 51 for more information on setting these registers.

Figure 129 shows the 25-bit frame data that encapsulates the peak detector value. The frame data is transmitted MSB first with five 5-bit subframes. Each subframe contains a start bit that can be used by a receiver to validate the deserialized data. Figure 130 shows the SPORT over JESD204B signal monitor data with a monitor period timer set to 80 samples.

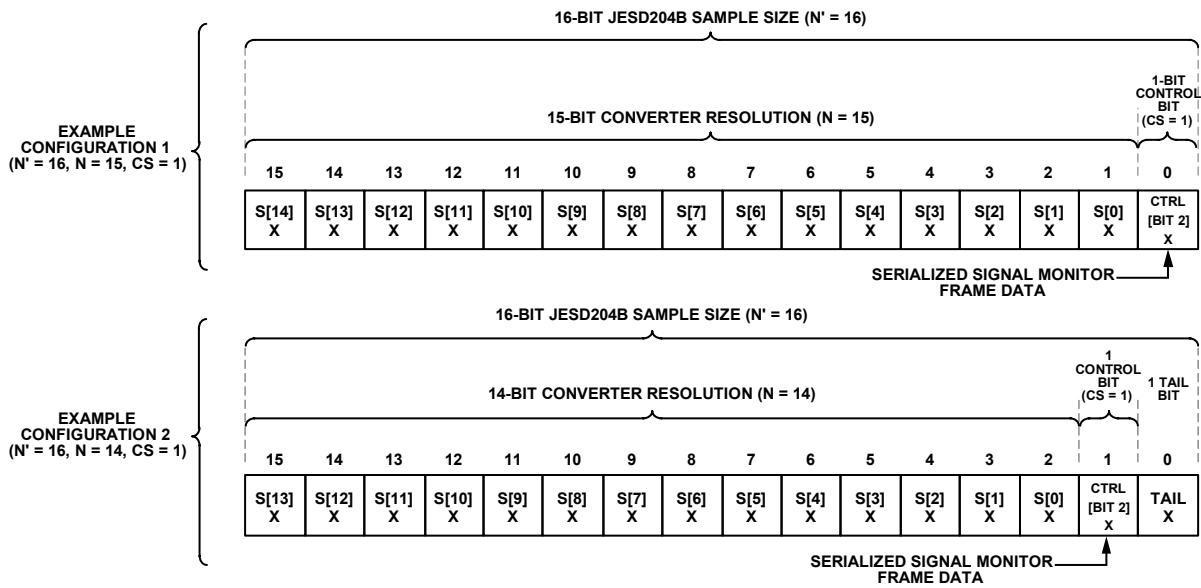

Figure 128. Signal Monitor Control Bit Locations

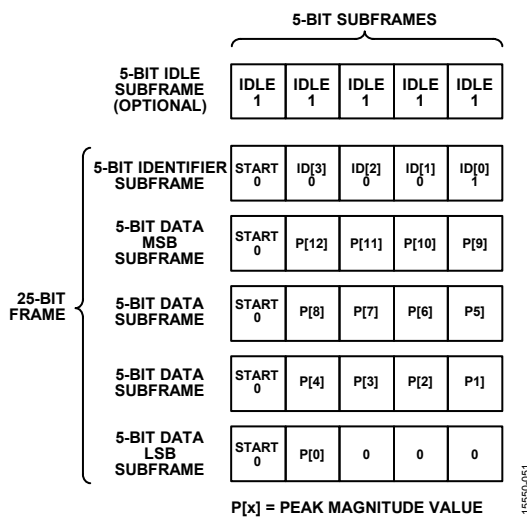
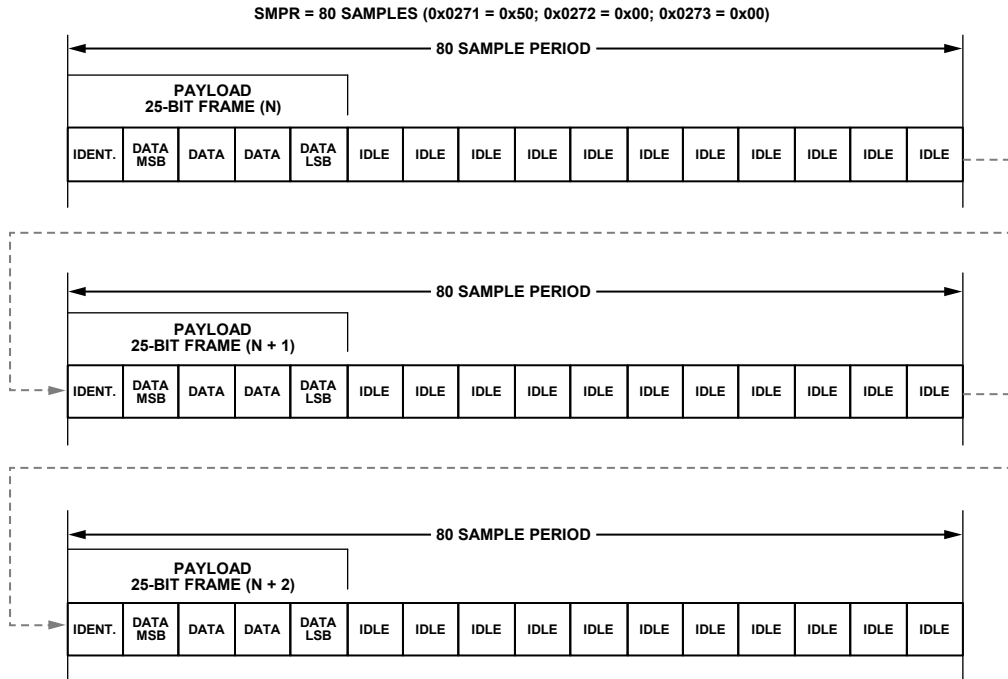

Figure 129. SPORT over JESD204B Signal Monitor Frame Data



19560-062

Figure 130. SPORT over JESD204B Signal Monitor Example with Period = 80 Samples

DIGITAL OUTPUTS

INTRODUCTION TO THE JESD204B INTERFACE

The AD9689 digital outputs are designed to the JEDEC standard JESD204B, serial interface for data converters. JESD204B is a protocol to link the AD9689 to a digital processing device over a serial interface with lane rates of up to 16 Gbps. The benefits of the JESD204B interface over LVDS include a reduction in required board area for data interface routing and an ability to enable smaller packages for converter and logic devices.

JESD204B OVERVIEW

The JESD204B data transmit block assembles the parallel data from the ADC into frames and uses 8-bit/10-bit encoding as well as optional scrambling to form serial output data. Lane synchronization is supported through the use of separate control characters during the initial establishment of the link. Additional control characters are embedded in the data stream to maintain synchronization thereafter. A JESD204B receiver is required to complete the serial link. For additional details on the JESD204B interface, refer to the JESD204B standard.

The AD9689 JESD204B data transmit block maps up to two physical ADCs or up to eight virtual converters (when DDCs are enabled) over a link. A link can be configured to use one, two, four, or eight JESD204B lanes. The JESD204B specification refers to a number of parameters to define the link, and these parameters must match between the JESD204B transmitter (the AD9689 output) and the JESD204B receiver (the logic device input).

The JESD204B link is described according to the following parameters:

- L is the number of lanes per converter device (lanes per link); AD9689 value = 1, 2, 4, or 8.
- M is the number of converters per converter device (virtual converters per link); AD9689 value = 1, 2, 4, or 8.
- F is the octets per frame; AD9689 value = 1, 2, 4, 8, or 16.
- N' is the number of bits per sample (JESD204B word size); AD9689 value = 8 or 16.
- N is the converter resolution; AD9689 value = 7 to 16.
- CS is the number of control bits per sample; AD9689 value = 0, 1, 2, or 3.

- K is the number of frames per multiframe; AD9689 value = 4, 8, 12, 16, 20, 24, 28, or 32.
- S is the samples transmitted per single converter per frame cycle; AD9689 value is set automatically based on L, M, F, and N'.
- HD is the high density mode; the AD9689 mode is set automatically based on L, M, F, and N'.
- CF is the number of control words per frame clock cycle per converter device; AD9689 value = 0.

Figure 131 shows a simplified block diagram of the AD9689 JESD204B link. By default, the AD9689 is configured to use two converters and eight lanes. Converter A data is output to SERDOUT0±, SERDOUT1±, SERDOUT2± and SERDOUT3±; and Converter B is output to SERDOUT4±, SERDOUT5±, SERDOUT6±, and SERDOUT7±. The AD9689 allows other configurations, such as combining the outputs of both converters onto a single lane, or changing the mapping of the A and B digital output paths. These modes are set up via the SPI register map, along with additional customizable options.

By default in the AD9689, the 14-bit converter word from each converter is broken into two octets (eight bits of data). Bit 13 (MSB) through Bit 6 are in the first octet. The second octet contains Bit 5 through Bit 0 (LSB) and two tail bits. The tail bits can be configured as zeros or as a pseudorandom number sequence. The tail bits can also be replaced with control bits indicating overrange, SYSREF±, or fast detect output.

The two resulting octets can be scrambled. Scrambling is optional; however, it is recommended to avoid spectral peaks when transmitting similar digital data patterns. The scrambler uses a self synchronizing, polynomial-based algorithm defined by the equation $1 + x^{14} + x^{15}$. The descrambler in the receiver is a self synchronizing version of the scrambler polynomial.

The two octets are then encoded with an 8-bit/10-bit encoder. The 8-bit/10-bit encoder works by taking eight bits of data (an octet) and encoding them into a 10-bit symbol. Figure 132 shows how the 14-bit data is taken from the ADC, how the tail bits are added, how the two octets are scrambled, and how the octets are encoded into two 10-bit symbols. Figure 132 shows the default data format.

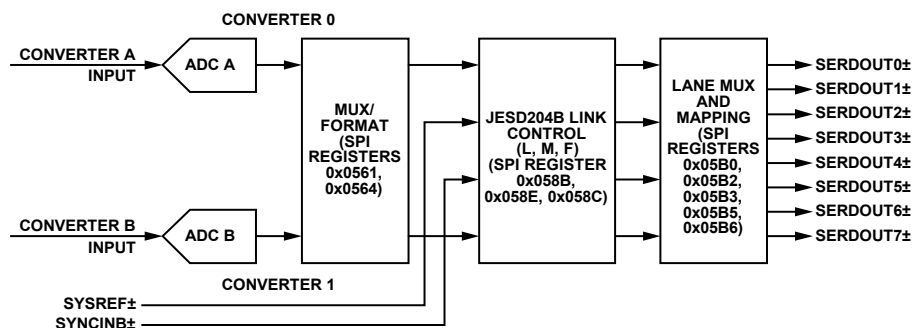

Figure 131. Transmit Link Simplified Block Diagram Showing Full Bandwidth Mode (Register 0x0200 = 0x00)

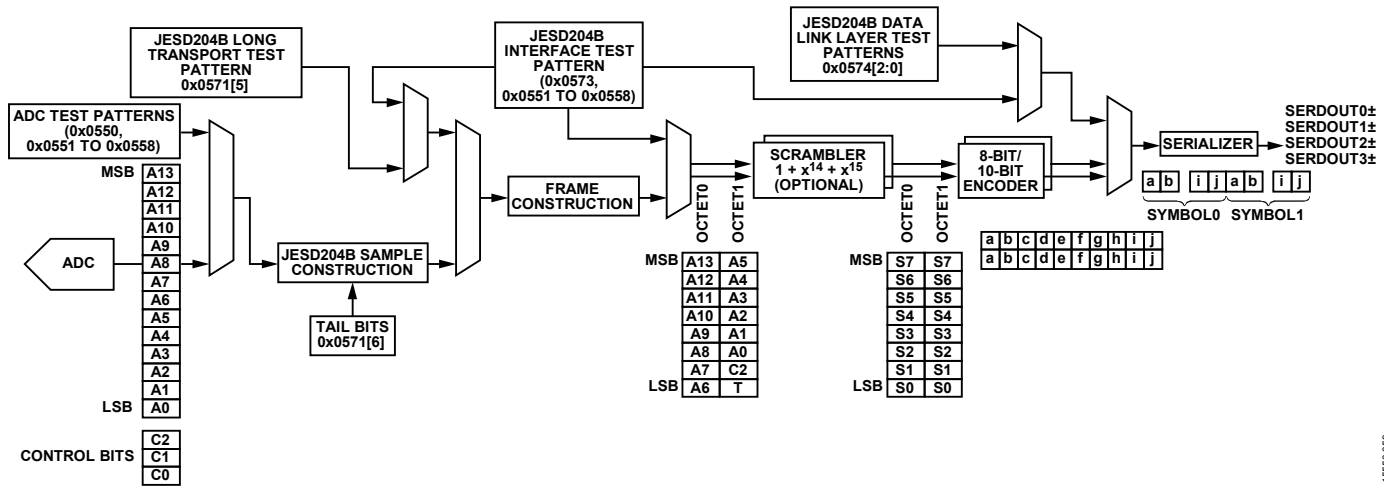

Figure 132. ADC Output Datapath Showing Data Framing

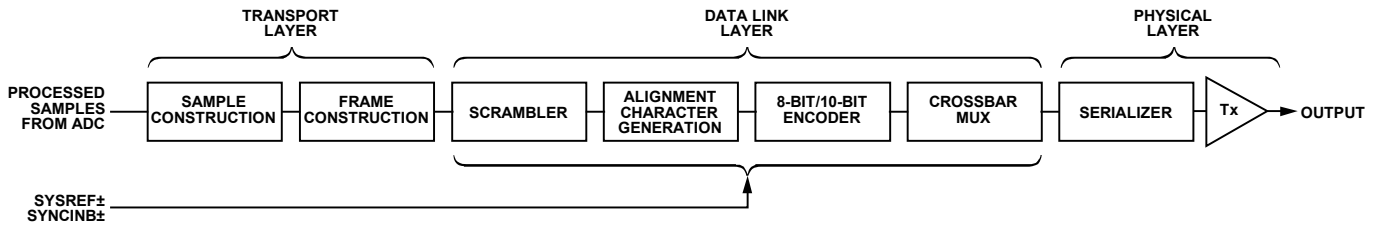

Figure 133. Data Flow

FUNCTIONAL OVERVIEW

The block diagram in Figure 133 shows the flow of data through the JESD204B hardware from the sample input to the physical output. The processing can be divided into layers that are derived from the open-source initiative (OSI) model widely used to describe the abstraction layers of communications systems. These layers are the transport layer, data link layer, and physical layer (serializer and output driver).

Transport Layer

The transport layer handles packing the data (consisting of samples and optional control bits) into JESD204B frames that are mapped to 8-bit octets. These octets are sent to the data link layer. The transport layer mapping is controlled by rules derived from the link parameters. Tail bits are added to fill gaps where required. The following equation can be used to determine the number of tail bits within a sample (JESD204B word):

$$T = N' - N - CS$$

Data Link Layer

The data link layer is responsible for the low level functions of passing data across the link. These functions include optionally scrambling the data, inserting control characters for multichip synchronization/lane alignment/monitoring, and encoding 8-bit octets into 10-bit symbols. The data link layer is also responsible for sending the initial lane alignment sequence (ILAS), which contains the link configuration data used by the receiver to verify the settings in the transport layer.

Physical Layer

The physical layer consists of the high speed circuitry clocked at the serial clock rate. In this layer, parallel data is converted into one, two, four, or eight lanes of high speed differential serial data.

JESD204B LINK ESTABLISHMENT

The AD9689 JESD204B transmitter (Tx) interface operates in Subclass 1 as defined in the JEDEC Standard JESD204B (July 2011 specification). The link establishment process is divided into the following steps: code group synchronization (CGS) and SYNCINB±, initial lane alignment sequence, and user data and error correction.

CGS and SYNCINB±

CGS is the process in which the JESD204B receiver finds the boundaries between the 10-bit symbols in the stream of data. During the CGS phase, the JESD204B transmit block transmits /K28.5/ characters. The receiver must locate /K28.5/ characters in its input data stream using clock and data recovery (CDR) techniques.

The receiver issues a synchronization request by asserting the SYNCINB± pin of the AD9689 low. The JESD204B Tx then begins sending /K/ characters. After the receiver synchronizes, it waits for the correct reception of at least four consecutive /K/ symbols. It then deasserts SYNCINB±. The AD9689 then transmits an ILAS on the following LMFC boundary.

For more information on the code group synchronization phase, refer to the JEDEC Standard JESD204B, July 2011, Section 5.3.3.1.

The SYNCINB± pin operation can also be controlled by the SPI. The SYNCINB± signal is a differential dc-coupled LVDS mode signal by default, but it can also be driven single-ended. For more information on configuring the SYNCINB± pin operation, refer to Register 0x0572.

The SYNCINB± pins can also be configured to run in CMOS (single-ended) mode, by setting Bit 4 in Register 0x0572. When running SYNCINB± in CMOS mode, connect the CMOS SYNCINB signal to Pin N13 (SYNCINB+) and leave Pin P13 (SYNCINB-) floating.

Initial Lane Alignment Sequence (ILAS)

The ILAS phase follows the CGS phase and begins on the next LMFC boundary. The ILAS consists of four multiframes, with an /R/ character marking the beginning and an /A/ character marking the end. The ILAS begins by sending an /R/ character followed by 0 to 255 ramp data for one multiframe. On the second multiframe, the link configuration data is sent, starting with the third character. The second character is a /Q/ character to confirm that the link configuration data is to follow. All undefined data slots are filled with ramp data. The ILAS sequence is never scrambled.

The ILAS sequence construction is shown in Figure 134. The four multiframes include the following:

- Multiframe 1 begins with an /R/ character (/K28.0/) and ends with an /A/ character (/K28.3/).
- Multiframe 2 begins with an /R/ character followed by a /Q/ character (/K28.4/), followed by link configuration parameters over 14 configuration octets (see Table 30) and ends with an /A/ character. Many of the parameter values are of the value – 1 notation.
- Multiframe 3 begins with an /R/ character (/K28.0/) and ends with an /A/ character (/K28.3/).
- Multiframe 4 begins with an /R/ character (/K28.0/) and ends with an /A/ character (/K28.3/).

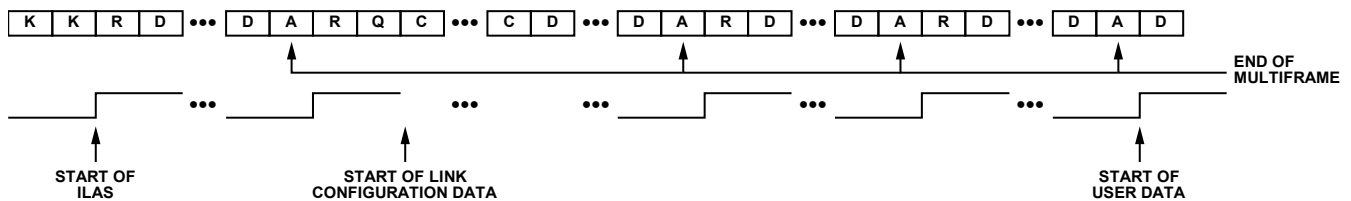

Figure 134. Initial Lane Alignment Sequence

Table 30. AD9689 Control Characters Used in JESD204B

Abbreviation	Control Symbol	8-Bit Value	10-Bit Value, RD = -1	10-Bit Value, RD = +1	Description
/R/	/K28.0/	000 11100	001111 0100	110000 1011	Start of multiframe
/A/	/K28.3/	011 11100	001111 0011	110000 1100	Lane alignment
/Q/	/K28.4/	100 11100	001111 0100	110000 1101	Start of link configuration data
/K/	/K28.5/	101 11100	001111 1010	110000 0101	Group synchronization
/F/	/K28.7/	111 11100	001111 1000	110000 0111	Frame alignment

¹ RD means running disparity.

User Data and Error Detection

After the initial lane alignment sequence completes, the user data is sent. Normally, within a frame, all characters are considered to be user data. However, to monitor the frame clock and multiframe clock synchronization, there is a mechanism for replacing characters with /F/ or /A/ alignment characters when the data meets certain conditions. These conditions are different for unscrambled and scrambled data. The scrambling operation is enabled by default; however, it can be disabled using the SPI.

For scrambled data, any 0xFC character at the end of a frame is replaced by an /F/, and any 0x7C character at the end of a multiframe is replaced by an /A/. The JESD204B receiver (Rx) checks for /F/ and /A/ characters in the received data stream and verifies that they only occur in the expected locations. If an unexpected /F/ or /A/ character is found, the receiver handles the situation by using dynamic realignment or asserting the SYNCINB± signal for more than four frames to initiate a resynchronization. For unscrambled data, if the final character of two subsequent frames is equal, the second character is replaced with an /F/ if it is at the end of a frame, and an /A/ if it is at the end of a multiframe.

Insertion of alignment characters can be modified using the SPI. The frame alignment character insertion (FACI) is enabled by default. More information on the link controls is available in the Memory Map section, Register 0x0571.

8-Bit/10-Bit Encoder

The 8-bit/10-bit encoder converts 8-bit octets into 10-bit symbols and inserts control characters into the stream when needed. The control characters used in JESD204B are shown in Table 30. The 8-bit/10-bit encoding ensures that the signal is dc balanced by using the same number of ones and zeros across multiple symbols.

The 8-bit/10-bit interface has options that can be controlled via the SPI. These operations include bypass and invert, and are troubleshooting tools for the verification of the digital front end (DFE). See the Memory Map section, Register 0x0572, Bits[2:1] for information on configuring the 8-bit/10-bit encoder.

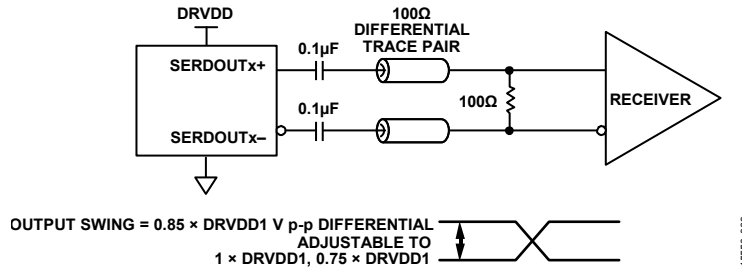

Figure 135. AC-Coupled Digital Output Termination Example

PHYSICAL LAYER (DRIVER) OUTPUTS

Digital Outputs, Timing, and Controls

The AD9689 physical layer consists of drivers that are defined in the JEDEC Standard JESD204B, July 2011. The differential digital outputs are powered up by default. The drivers use a dynamic $100\ \Omega$ internal termination to reduce unwanted reflections.

Place a $100\ \Omega$ differential termination resistor at each receiver input to result in a nominal $0.85 \times \text{DRVDD1}$ V p-p swing at the receiver (see Figure 135). The swing is adjustable through the SPI registers. AC coupling is recommended to connect to the receiver. See the Memory Map section (Register 0x05C0 to Register 0x05C3 in Table 51) for more details.

The AD9689 digital outputs can interface with custom application specific integrated circuits (ASICs) and field programmable gate array (FPGA) receivers, providing superior switching performance in noisy environments. Single point to point network topologies are recommended with a single differential $100\ \Omega$ termination resistor placed as close to the receiver inputs as possible.

If there is no far end receiver termination, or if there is poor differential trace routing, timing errors can result. To avoid such timing errors, it is recommended that the trace length be less than six inches, and that the differential output traces be close together and at equal lengths.

Figure 136 to Figure 138 show an example of the digital output data eye, jitter histogram, and bathtub curve for one AD9689 lane running at 16 Gbps. The format of the output data is twos complement by default. To change the output data format, see the Memory Map section (Register 0x0561 in Table 51).

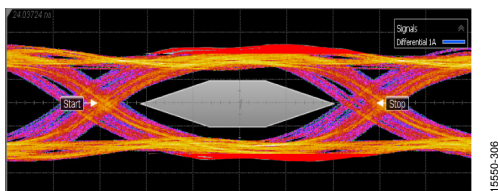
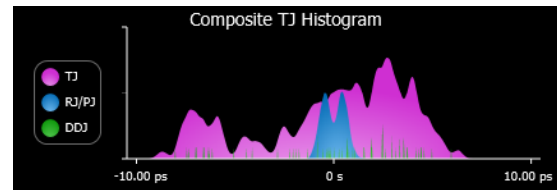
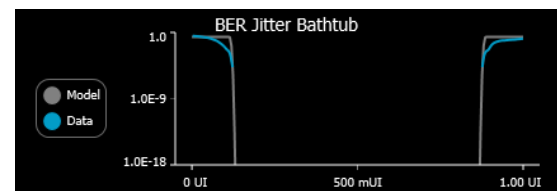
Figure 136. Digital Outputs Data Eye, External $100\ \Omega$ Terminations at 16 GbpsFigure 137. Digital Outputs Jitter Histogram, External $100\ \Omega$ Terminations at 16 GbpsFigure 138. Digital Outputs Bathtub Curve, External $100\ \Omega$ Terminations at 16 Gbps

De-Emphasis

De-emphasis enables the receiver eye diagram mask to be met in conditions where the interconnect insertion loss does not meet the JESD204B specification. Use the de-emphasis feature only when the receiver is unable to recover the clock due to excessive insertion loss. Under normal conditions, it is disabled to conserve power. Additionally, enabling and setting too high a de-emphasis value on a short link can cause the receiver eye diagram to fail. Use the de-emphasis setting with caution because it can increase electromagnetic interference (EMI). See the Memory Map section (Register 0x05C4 to Register 0x05CB in Table 51) for more details.

Phase-Locked Loop (PLL)

The PLL generates the serializer clock, which operates at the JESD204B lane rate. The status of the PLL lock can be checked in the PLL locked status bit (Register 0x056F, Bit 7). This read only bit notifies the user if the PLL achieved a lock for the specific setup. Register 0x056F also has a loss of lock (LOL) sticky bit (Bit 3) that notifies the user that a LOL is detected. The sticky bit can be reset by issuing a JESD204B link restart (Register 0x0571 = 0x15, followed by Register 0x0571 = 0x14). Refer to Table 32 for the reinitialization of the link following a link power cycle.

The JESD204B lane rate control, Bits[7:4] of Register 0x056E, must be set to correspond with the lane rate. Table 31 shows the lane rates supported by the AD9689 using Register 0x056E.

Table 31. AD9689 Register 0x056E Supported Lane Rates

Value	Lane Rate
0x00	Lane rate = 6.75 Gbps to 13.5 Gbps (default for AD9689)
0x10	Lane rate = 3.375 Gbps to 6.75 Gbps
0x30	Lane rate = 13.5 Gbps to 16 Gbps
0x50	Lane rate = 1.6875 Gbps to 3.375 Gbps

$f_s \times 4$ MODE

$f_s \times 4$ mode adds a separate packing mode to a JESD204B transmitter/receiver to set the serial lane rate at four times the sample rate (f_s).

The JESD204B link settings are

- L = 8
- M = 2
- F = 2
- S = 5
- N' = 12
- N = 12
- CS = 0
- CF = 2
- HD = 1

However, CF = 2 is not supported by the design; therefore, the following link parameters are used along with separate packing:

- L = 8
- M = 2
- F = 2
- S = 4
- N' = 16
- N = 16

- CS = 0
- CF = 0
- HD = 0

In $f_s \times 4$ mode, five 12-bit ADC samples (along with an extra 4 bits) are packed into four 16-bit JESD204B samples to create a 64-bit frame.

The following SPI writes are necessary to place the device in $f_s \times 4$ mode:

- Register 0x0570 = 0xFE. This setting places the device in M = 2, L = 8, $f_s \times 4$ mode.
- Register 0x058B = 0x0F. This setting places the device CS = 0, N' = 16 mode.
- Register 0x058F = 0x2F. This setting places the device in Subclass 1 mode, N = 16.

The transmit architecture of $f_s \times 4$ mode is shown in Figure 139, and the receive portion is shown in Figure 140. $f_s \times 4$ mode only works in full bandwidth mode (Register 0x0200 = 0x00).

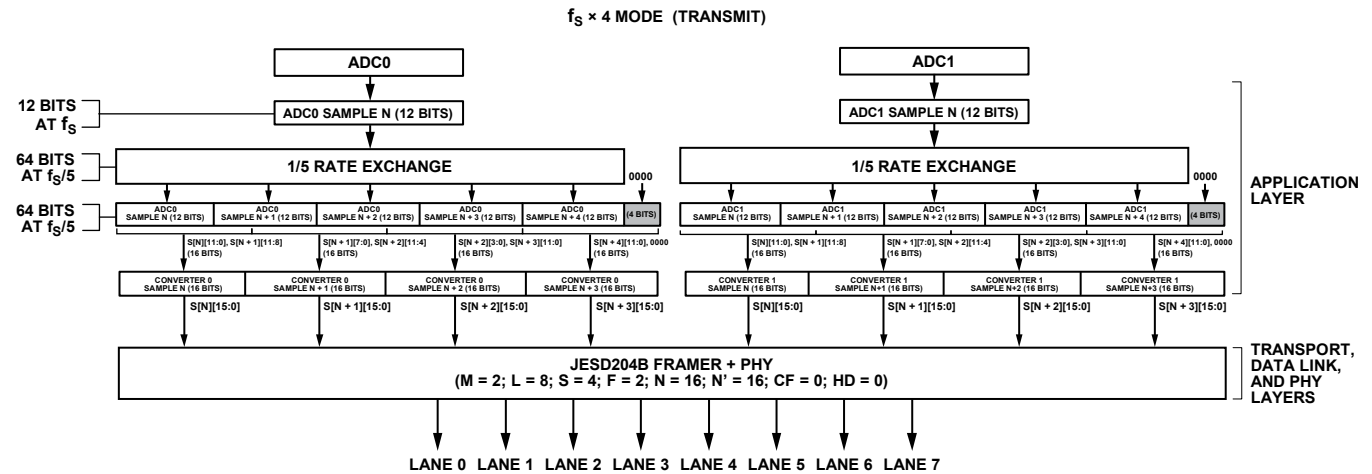

Figure 139. $f_s \times 4$ Mode (Transmit)

15550-309

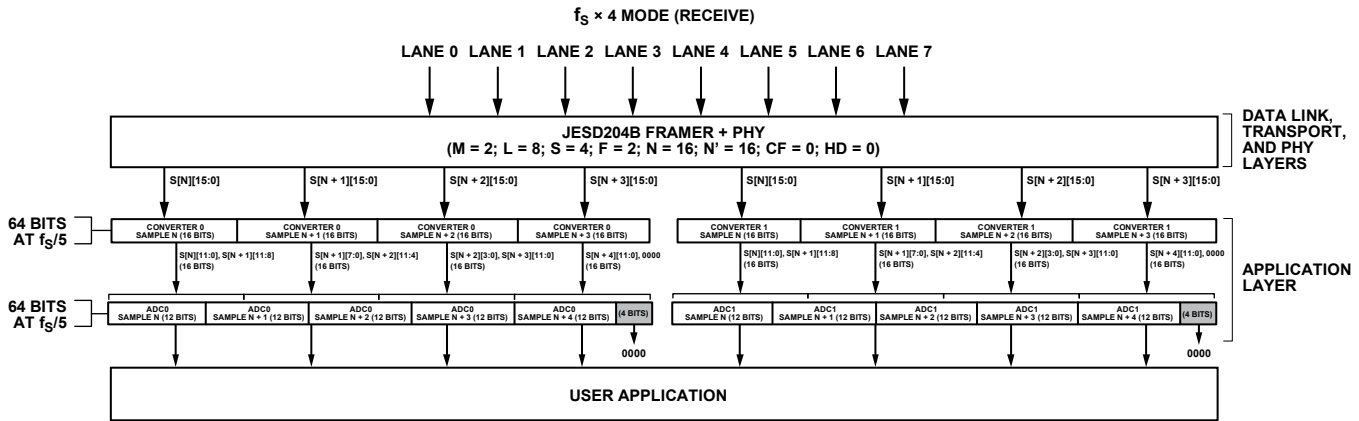

Figure 140. $f_s \times 4$ Mode (Receive)

SETTING UP THE AD9689 DIGITAL INTERFACE

To ensure proper operation of the AD9689 at startup, some SPI writes are required to initialize the link. Additionally, these registers must be written every time the ADC is reset. Any one of the following resets warrants the initialization routine for the digital interface:

- Hard reset, as with power-up.
- Power-up using the PDWN pin.
- Power-up using the SPI via Register 0x0002, Bits[1:0].
- SPI soft reset by setting Register 0x0000 = 0x81.
- Datapath soft reset by setting Register 0x0001 = 0x02.
- JESD204B link power cycle by setting Register 0x0571 = 0x15, then 0x14.

The initialization SPI writes are as shown in Table 32.

Table 32. AD9689 JESD204B Initialization

Register	Value	Comment
0x1228	0x4F	Reset JESD204B start-up circuit
0x1228	0x0F	JESD204B start-up circuit in normal operation
0x1222	0x00	JESD204B PLL force normal operation
0x1222	0x04	Reset JESD204B PLL calibration
0x1222	0x00	JESD204B PLL normal operation
0x1262	0x08	Clear loss of lock bit
0x1262	0x00	Loss of lock bit normal operation

The AD9689 has one JESD204B link. The serial outputs (SERDOUT0± to SERDOUT7±) are considered to be part of one JESD204B link. The basic parameters that determine the link setup are

- Number of lanes per link (L)
- Number of converters per link (M)
- Number of octets per frame (F)

If the internal DDCs are used for on-chip digital processing, M represents the number of virtual converters. The virtual converter mapping setup is shown in Figure 102.

The maximum lane rate allowed by the AD9689 is 16 Gbps. The lane rate is related to the JESD204B parameters using the following equation:

$$\text{Lane Rate} = \frac{M \times N' \times \left(\frac{10}{8}\right) \times f_{OUT}}{L}$$

where $f_{OUT} = \frac{f_{ADC_CLOCK}}{\text{Decimation Ratio}}$

The decimation ratio (DCM) is the parameter programmed in Register 0x0201.

Use the following procedure to configure the output:

1. Power down the link.
2. Select the JESD204B link configuration options.
3. Configure the detailed options.
4. Set output lane mapping (optional).
5. Set additional driver configuration options (optional).
6. Power up the link.
7. Initialize the JESD204B link by issuing the commands described in Table 32.

If the lane rate calculated is less than 6.25 Gbps, select the low lane rate option by programming a value of 0x10 to Register 0x056E.

Table 33 and Table 35 show the JESD204B output configurations supported for both $N' = 16$ and $N' = 8$ for a given number of virtual converters. Take care to ensure that the serial lane rate for a given configuration is within the supported range of 3.4 Gbps to 16 Gbps.

Table 33. JESD204B Output Configurations for N' = 16¹

Number of Virtual Converters Supported (Same as M)	JESD204B Serial Lane Rate ²	Supported Decimation Rates				JESD204B Transport Layer Settings ³								
		Lane Rate = 1.6875 Gbps to 3.375 Gbps	Lane Rate = 3.375 Gbps to 6.75 Gbps	Lane Rate = 6.75 Gbps to 13.5 Gbps	Lane Rate = 13.5 Gbps to 16 Gbps	L	M	F	S	HD	N	N'	CS	K
		1	20 × f _{OUT}	2, 4, 5, 6, 8, 10, 12, 20, 24	1, 2, 3, 4, 5, 6, 8, 10, 12	1, 2, 3, 4, 5, 6, 8	1, 2, 3, 4	1	1	2	1	0	8 to 16	16
	20 × f _{OUT}	2, 4, 5, 6, 8, 10, 12, 20, 24	1, 2, 3, 4, 5, 6, 8, 10, 12	1, 2, 3, 4, 5, 6, 8	1, 2, 3, 4	1	1	4	2	0	8 to 16	16	0 to 3	See Note 4
	10 × f _{OUT}	1, 2, 3, 4, 5, 6, 8, 10, 12	1, 2, 3, 4, 5, 6, 8	1, 2, 3, 4	1, 2	2	1	1	1	1	8 to 16	16	0 to 3	See Note 4
	10 × f _{OUT}	1, 2, 3, 4, 5, 6, 8, 10, 12	1, 2, 3, 4, 5, 6, 8	1, 2, 3, 4	1, 2	2	1	2	2	0	8 to 16	16	0 to 3	See Note 4
	5 × f _{OUT}	1, 2, 3, 4, 5, 6, 8	1, 2, 3, 4	1, 2	1	4	1	1	2	1	8 to 16	16	0 to 3	See Note 4
	5 × f _{OUT}	1, 2, 3, 4, 5, 6, 8	1, 2, 3, 4	1, 2	1	4	1	2	4	0	8 to 16	16	0 to 3	See Note 4
	2.5 × f _{OUT}	1, 2, 3, 4	1, 2	1	1	8	1	1	4	1	8 to 16	16	0 to 3	See Note 4
	2.5 × f _{OUT}	1, 2, 3, 4	1, 2	1	1	8	1	2	8	0	8 to 16	16	0 to 3	See Note 4
2	40 × f _{OUT}	4, 8, 10, 12, 15, 16, 20, 24, 30, 40, 48	2, 4, 5, 6, 8, 10, 12, 15, 16, 20, 24, 30	1, 2, 3, 4, 5, 6, 8, 10, 12, 15, 16	1, 2, 3, 4, 5, 6, 8	1	2	4	1	0	8 to 16	16	0 to 3	See Note 4
	40 × f _{OUT}	4, 8, 10, 12, 15, 16, 20, 24, 30, 40, 48	2, 4, 5, 6, 8, 10, 12, 15, 16, 20, 24, 30	1, 2, 3, 4, 5, 6, 8, 10, 12, 15, 16	1, 2, 3, 4, 5, 6, 8	1	2	8	2	0	8 to 16	16	0 to 3	See Note 4
	20 × f _{OUT}	2, 4, 5, 6, 8, 10, 12, 15, 16, 20, 24, 30	1, 2, 3, 4, 5, 6, 8, 10, 12, 15, 16	1, 2, 3, 4, 5, 6, 8	1, 2, 3, 4	2	2	2	1	0	8 to 16	16	0 to 3	See Note 4
	20 × f _{OUT}	2, 4, 5, 6, 8, 10, 12, 15, 16, 20, 24, 30	1, 2, 3, 4, 5, 6, 8, 10, 12, 15, 16	1, 2, 3, 4, 5, 6, 8	1, 2, 3, 4	2	2	4	2	0	8 to 16	16	0 to 3	See Note 4
	10 × f _{OUT}	1, 2, 3, 4, 5, 6, 8, 10, 12, 15, 16	1, 2, 3, 4, 5, 6, 8	1, 2, 3, 4	1, 2	4	2	1	1	1	8 to 16	16	0 to 3	See Note 4
	10 × f _{OUT}	1, 2, 3, 4, 5, 6, 8, 10, 12, 15, 16	1, 2, 3, 4, 5, 6, 8	1, 2, 3, 4	1, 2	4	2	2	2	0	8 to 16	16	0 to 3	See Note 4
	5 × f _{OUT}	1, 2, 3, 4, 5, 6, 8	1, 2, 3, 4	1, 2	1	8	2	1	2	1	8 to 16	16	0 to 3	See Note 4
	5 × f _{OUT}	1, 2, 3, 4, 5, 6, 8	1, 2, 3, 4	1, 2	1	8	2	2	4	0	8 to 16	16	0 to 3	See Note 4
4	80 × f _{OUT}	8, 16, 20, 24, 30, 40, 48	4, 8, 10, 12, 16, 20, 24, 30, 40, 48	2, 4, 6, 8, 10, 12, 16, 20, 24, 30	2, 4, 6, 8, 10, 12, 16	1	4	8	1	0	8 to 16	16	0 to 3	See Note 4
	40 × f _{OUT}	4, 8, 10, 12, 15, 16, 20, 24, 30, 40, 48	2, 4, 5, 6, 8, 10, 12, 15, 16, 20, 24, 30	1, 2, 3, 4, 5, 6, 8, 10, 12, 15, 16	1, 2, 3, 4, 5, 6, 8	2	4	4	1	0	8 to 16	16	0 to 3	See Note 4
	40 × f _{OUT}	4, 8, 10, 12, 15, 16, 20, 24, 30, 40, 48	2, 4, 5, 6, 8, 10, 12, 15, 16, 20, 24, 30	1, 2, 3, 4, 5, 6, 8, 10, 12, 15, 16	1, 2, 3, 4, 5, 6, 8	2	4	8	2	0	8 to 16	16	0 to 3	See Note 4
	20 × f _{OUT}	2, 4, 5, 6, 8, 10, 12, 15, 16, 20, 24, 30	1, 2, 3, 4, 5, 6, 8, 10, 12, 15, 16	1, 2, 3, 4, 5, 6, 8	1, 2, 3, 4	4	4	2	1	0	8 to 16	16	0 to 3	See Note 4
	20 × f _{OUT}	2, 4, 5, 6, 8, 10, 12, 15, 16, 20, 24, 30	1, 2, 3, 4, 5, 6, 8, 10, 12, 15, 16	1, 2, 3, 4, 5, 6, 8	1, 2, 3, 4	4	4	4	2	0	8 to 16	16	0 to 3	See Note 4
	10 × f _{OUT}	1, 2, 3, 4, 5, 6, 8, 10, 12, 15, 16	1, 2, 3, 4, 5, 6, 8	1, 2, 3, 4	1, 2	8	4	1	1	1	8 to 16	16	0 to 3	See Note 4
	10 × f _{OUT}	1, 2, 3, 4, 5, 6, 8, 10, 12, 15, 16	1, 2, 3, 4, 5, 6, 8	1, 2, 3, 4	1, 2	8	4	2	2	0	8 to 16	16	0 to 3	See Note 4

Number of Virtual Converters Supported (Same as M)	JESD204B Serial Lane Rate ²	Supported Decimation Rates				JESD204B Transport Layer Settings ³								
		Lane Rate = 1.6875 Gbps to 3.375 Gbps	Lane Rate = 3.375 Gbps to 6.75 Gbps	Lane Rate = 6.75 Gbps to 13.5 Gbps	Lane Rate = 13.5 Gbps to 16 Gbps	L	M	F	S	HD	N	N'	CS	K
		8	$160 \times f_{OUT}$	16, 40, 48	8, 16, 20, 24, 40, 48	4, 8, 12, 16, 20, 24, 40, 48	4, 8, 12, 16, 20, 24	1	8	16	1	0	8 to 16	16
	$80 \times f_{OUT}$	8, 16, 20, 24, 40, 48	4, 8, 10, 12, 16, 20, 24, 40, 48	2, 4, 6, 8, 10, 12, 16, 20, 24	2, 4, 6, 8, 10, 12, 16	2	8	8	1	0	8 to 16	16	0 to 3	See Note 4
	$40 \times f_{OUT}$	4, 8, 10, 12, 16, 20, 24, 40, 48	2, 4, 6, 8, 10, 12, 16, 20, 24	2, 4, 6, 8, 10, 12, 16	2, 4, 6, 8	4	8	4	1	0	8 to 16	16	0 to 3	See Note 4
	$40 \times f_{OUT}$	4, 8, 10, 12, 16, 20, 24, 40, 48	2, 4, 6, 8, 10, 12, 16, 20, 24	2, 4, 6, 8, 10, 12, 16	2, 4, 6, 8	4	8	8	2	0	8 to 16	16	0 to 3	See Note 4
	$20 \times f_{OUT}$	2, 4, 6, 8, 10, 12, 16, 20, 24	2, 4, 6, 8, 10, 12, 16	2, 4, 6, 8	2, 4	8	8	2	1	0	8 to 16	16	0 to 3	See Note 4
	$20 \times f_{OUT}$	2, 4, 6, 8, 10, 12, 16, 20, 24	2, 4, 6, 8, 10, 12, 16	2, 4, 6, 8	2, 4	8	8	4	2	0	8 to 16	16	0 to 3	See Note 4

¹ Due to the internal clock requirements, only certain decimation rates are supported for certain link parameters.

² JESD204B transport layer descriptions are as follows: L is the number of lanes per converter device (lanes per link); M is the number of virtual converters per converter device (virtual converters per link); F is the octets per frame; S is the samples transmitted per virtual converter per frame cycle; HD is the high density mode; N is the virtual converter resolution (in bits); N' is the total number of bits per sample (JESD204B word size); CS is the number of control bits per conversion sample; K is the number of frames per multiframe.

³ f_{ADC_CLK} is the ADC sample rate; DCM = chip decimation ratio; f_{OUT} is the output sample rate = f_{ADC_CLK}/DCM ; SLR is the JESD204B serial lane rate. The following equations must be met due to internal clock divider requirements: $SLR \geq 1.6875$ Gbps and $SLR \leq 15.5$ Gbps; $SLR/40 \leq f_{ADC_CLK}$; least common multiple ($20 \times DCM \times f_{OUT}/SLR, DCM$) ≤ 64 . When the SLR is ≤ 16000 Mbps and > 13500 Mbps, Register 0x056E must be set to 0x30. When the SLR is ≤ 13500 Mbps and ≥ 6750 Mbps, Register 0x056E must be set to 0x00. When the SLR is < 6750 Mbps and ≥ 3375 Mbps, Register 0x056E must be set to 0x10. When the SLR is < 3375 Mbps and ≥ 1687.5 Mbps, Register 0x056E must be set to 0x50.

⁴ Only valid $K \times F$ values that are divisible by 4 are supported: for $F = 1$, $K = 20, 24, 28, 32$; for $F = 2$, $K = 12, 16, 20, 24, 28, 32$; for $F = 4$, $K = 8, 12, 16, 20, 24, 28, 32$; for $F = 8$, $K = 4, 8, 12, 16, 20, 24, 28, 32$; and for $F = 16$, $K = 4, 8, 12, 16, 20, 24, 28, 32$.

Table 34. JESD204B Output Configurations (N' = 12)¹

No. of Virtual Converters Supported (Same Value as M)	Serial Lane Rate ²	Supported Decimation Rates				JESD204B Transport Layer Settings ³								
		Lane Rate = 1.6875 Gbps to 3.375 Gbps	Lane Rate = 3.375 Gbps to 6.75 Gbps	Lane Rate = 6.75 Gbps to 13.5 Gbps	Lane Rate = 13.5 Gbps to 16 Gbps	L	M	F	S	HD	N	N'	L	K
		1	15 × f _{OUT}	3, 6, 12	3, 6, 12	3, 6		1	1	3	2	0	8 to 12	12
	7.5 × f _{OUT}	3, 6	3, 6	3		2	1	3	4	1	8 to 12	12	0 to 3	See Note 4
	7.5 × f _{OUT}	3, 6	3, 6	3		2	1	6	8	0	8 to 12	12	0 to 3	See Note 4
	5 × f _{OUT}	1, 2, 3, 4, 5, 6, 8	1, 2, 3, 4	1, 2	1	3	1	1	2	1	8 to 12	12	0 to 3	See Note 4
2	30 × f _{OUT}	3, 6, 12, 24	3, 6, 12, 24	3, 6, 12		1	2	3	1	0	8 to 12	12	0 to 3	See Note 4
	15 × f _{OUT}	3, 6, 12	3, 6, 12	3, 6		2	2	3	2	0	8 to 12	12	0 to 3	See Note 4
	10 × f _{OUT}	1, 2, 3, 4, 5, 6, 8, 10, 12, 16	1, 2, 3, 4, 5, 6, 8	1, 2, 3, 4	1, 2	3	2	1	1	1	8 to 12	12	0 to 3	See Note 4
	7.5 × f _{OUT}	3, 6	3, 6	3		4	2	3	4	0	8 to 12	12	0 to 3	See Note 4
4	60 × f _{OUT}	6, 12, 24, 48	3, 6, 12, 24, 48	3, 6, 12, 24		1	4	6	1	0	8 to 12	12	0 to 3	See Note 4
	30 × f _{OUT}	3, 6, 12, 24	3, 6, 12, 24	3, 6, 12		2	4	3	1	0	8 to 12	12	0 to 3	See Note 4
	20 × f _{OUT}	2, 4, 5, 6, 8, 10, 12, 16, 20, 24	1, 2, 3, 4, 5, 6, 8, 10, 12, 16	1, 2, 3, 4, 5, 6, 8	1, 2, 3, 4	3	4	2	1	1	8 to 12	12	0 to 3	See Note 4
	15 × f _{OUT}	3, 6, 12	3, 6, 12	3, 6		4	4	3	2	0	8 to 12	12	0 to 3	See Note 4
8	60 × f _{OUT}	6, 12, 24, 48	6, 12, 24, 48	6, 12, 24		2	8	6	1	0	8 to 12	12	0 to 3	See Note 4
	30 × f _{OUT}	6, 12, 24	6, 12, 24	6, 12		4	8	3	1	0	8 to 12	12	0 to 3	See Note 4

¹ Due to the internal clock requirements, only certain decimation rates are supported for certain link parameters.

² fADC_CLK is the ADC sample rate; DCM is the chip decimation ratio; fOUT is the output sample rate = fADC_CLK/DCM; SLR is the JESD204B serial lane rate. The following equations must be met due to internal clock divider requirements: SLR ≥ 1.6875 Gbps and SLR ≤ 15.5 Gbps; SLR/40 ≤ fADC_CLK; least common multiple (20 × DCM × fOUT/SLR, DCM) ≤ 64. When the SLR is ≤ 16000 Mbps and > 13500 Mbps, Register 0x056E must be set to 0x30. When the SLR is ≤ 13500 Mbps and ≥ 6750 Mbps, Register 0x056E must be set to 0x00. When the SLR is < 6750 Mbps and ≥ 3375 Mbps, Register 0x056E must be set to 0x10. When the SLR is < 3375 Mbps and ≥ 1687.5 Mbps, Register 0x056E must be set to 0x50.

³ JESD204B transport layer descriptions are as follows: L is the number of lanes per converter device (lanes per link); M is the number of virtual converters per converter device (virtual converters per link); F is the octets per frame; S is the samples transmitted per virtual converter per frame cycle; HD is the high density mode; N is the virtual converter resolution (in bits); N' is the total number of bits per sample (JESD204B word size); CS is the number of control bits per conversion sample; K is the number of frames per multiframe.

⁴ Only valid K × F values that are divisible by 4 are supported: for F = 1, K = 20, 24, 28, 32; for F = 2, K = 12, 16, 20, 24, 28, 32; for F = 4, K = 8, 12, 16, 20, 24, 28, 32; for F = 8, K = 4, 8, 12, 16, 20, 24, 28, 32; and for F = 16, K = 4, 8, 12, 16, 20, 24, 28, 32.

Table 35. JESD204B Output Configurations for $N' = 8$ ¹

No. of Virtual Converters Supported (Same Value as M)	Serial Lane Rate ²	Supported Decimation Rates				JESD204B Transport Layer Settings ³								
		Lane Rate = 1.6875 Gbps to 3.375 Gbps	Lane Rate = 3.375 Gbps to 6.75 Gbps	Lane Rate = 6.75 Gbps to 13.5 Gbps	Lane Rate = 13.5 Gbps to 16 Gbps	L	M	F	S	HD	N	N'	CS	K
		1	$10 \times f_{OUT}$	1, 2, 3, 4, 5, 6, 8, 10, 12	1, 2, 3, 4, 5, 6, 8	1, 2, 3, 4	1, 2	1	1	1	1	0	7 to 8	8
1	$10 \times f_{OUT}$	1, 2, 3, 4, 5, 6, 8, 10, 12	1, 2, 3, 4, 5, 6, 8	1, 2, 3, 4	1, 2	1	1	2	2	0	7 to 8	8	0 to 1	See Note 4
1	$5 \times f_{OUT}$	1, 2, 3, 4, 5, 6, 8	1, 2, 3, 4	1, 2	1	2	1	1	2	0	7 to 8	8	0 to 1	See Note 4
1	$5 \times f_{OUT}$	1, 2, 3, 4, 5, 6, 8	1, 2, 3, 4	1, 2	1	2	1	2	4	0	7 to 8	8	0 to 1	See Note 4
1	$5 \times f_{OUT}$	1, 2, 3, 4, 5, 6, 8	1, 2, 3, 4	1, 2	1	2	1	4	8	0	7 to 8	8	0 to 1	See Note 4
1	$2.5 \times f_{OUT}$	1, 2, 3, 4	1, 2	1	1	4	1	1	4	0	7 to 8	8	0 to 1	See Note 4
1	$2.5 \times f_{OUT}$	1, 2, 3, 4	1, 2	1	1	4	1	2	8	0	7 to 8	8	0 to 1	See Note 4
2	$20 \times f_{OUT}$	2, 4, 5, 6, 8, 10, 12, 15, 16, 20, 24, 30	1, 2, 3, 4, 5, 6, 8, 10, 12, 15, 16	1, 2, 3, 4, 5, 6, 8	1, 2, 3, 4	1	2	2	1	0	7 to 8	8	0 to 1	See Note 4
2	$10 \times f_{OUT}$	1, 2, 3, 4, 5, 6, 8, 10, 12, 15, 16	1, 2, 3, 4, 5, 6, 8	1, 2, 3, 4	1, 2	2	2	1	1	0	7 to 8	8	0 to 1	See Note 4
2	$10 \times f_{OUT}$	1, 2, 3, 4, 5, 6, 8, 10, 12, 15, 16	1, 2, 3, 4, 5, 6, 8	1, 2, 3, 4	1, 2	2	2	2	2	0	7 to 8	8	0 to 1	See Note 4
2	$5 \times f_{OUT}$	1, 2, 3, 4, 5, 6, 8	1, 2, 3, 4	1, 2	1	4	2	1	2	0	7 to 8	8	0 to 1	See Note 4
2	$5 \times f_{OUT}$	1, 2, 3, 4, 5, 6, 8	1, 2, 3, 4	1, 2	1	4	2	2	4	0	7 to 8	8	0 to 1	See Note 4
2	$5 \times f_{OUT}$	1, 2, 3, 4, 5, 6, 8	1, 2, 3, 4	1, 2	1	4	2	4	8	0	7 to 8	8	0 to 1	See Note 4

¹ Due to the internal clock requirements, only certain decimation rates are supported for certain link parameters.

² f_{ADC_CLK} is the ADC sample rate; DCM is the chip decimation ratio; f_{OUT} is the output sample rate = f_{ADC_CLK}/DCM ; SLR is the JESD204B serial lane rate. The following equations must be met due to internal clock divider requirements: $SLR \geq 1.6875$ Gbps and $SLR \leq 15.5$ Gbps; $SLR/40 \leq f_{ADC_CLK}$; least common multiple ($20 \times DCM \times f_{OUT}/SLR, DCM$) ≤ 64 . When the SLR is ≤ 16000 Mbps and > 13500 Mbps, Register 0x056E must be set to 0x30. When the SLR is ≤ 13500 Mbps and ≥ 6750 Mbps, Register 0x056E must be set to 0x00. When the SLR is < 6750 Mbps and ≥ 3375 Mbps, Register 0x056E must be set to 0x10. When the SLR is < 3375 Mbps and ≥ 1687.5 Mbps, Register 0x056E must be set to 0x50.

³ JESD204B transport layer descriptions are as follows: L is the number of lanes per converter device (lanes per link); M is the number of virtual converters per converter device (virtual converters per link); F is the octets per frame; S is the samples transmitted per virtual converter per frame cycle; HD is the high density mode; N is the virtual converter resolution (in bits); N' is the total number of bits per sample (JESD204B word size); CS is the number of control bits per conversion sample; K is the number of frames per multiframe.

⁴ Only valid $K \times F$ values that are divisible by 4 are supported: for $F = 1$, $K = 20, 24, 28, 32$; for $F = 2$, $K = 12, 16, 20, 24, 28, 32$; for $F = 4$, $K = 8, 12, 16, 20, 24, 28, 32$; for $F = 8$, $K = 4, 8, 12, 16, 20, 24, 28, 32$; and for $F = 16$, $K = 4, 8, 12, 16, 20, 24, 28, 32$.

Example 1—Full Bandwidth Mode

Figure 141. Full Bandwidth Mode

The AD9689 is set up as shown in Figure 141, with the following configurations:

- Two 14-bit converters at 2.56 GSPS.
- Full bandwidth application layer mode.
- Decimation filters bypassed.

The JESD204B output configuration is as follows:

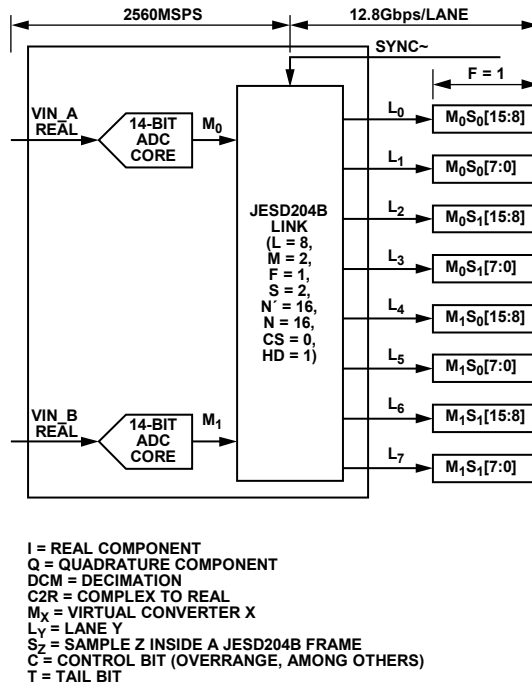
- Two virtual converters required (see Table 33).
- Output sample rate (f_{OUT}) = $2560/1 = 2560$ MSPS.

The JESD204B supported output configurations are as follows (see Table 33):

- $N' = 16$ bits.
- $N = 14$ bits.
- $L = 8, M = 2$, and $F = 1$, or $L = 8, M = 2$, and $F = 2$.
- $CS = 0$.
- $K = 32$.
- Output serial lane rate = 12.8 Gbps per lane.
- The PLL control register, Register 0x056E, is set to 0x00.

Set up the AD9689 in this mode using the following sequence:

1. Write 0x81 to Register 0x0000 (SPI soft reset).
2. Wait 5 ms to 10 ms.
3. Write 0x00 to Register 0x0200 (full bandwidth mode).
4. Write 0x00 to Register 0x0201 (chip decimation ratio = 1).
5. Write 0x15 to Register 0x0571 (JESD204B link power-down).
6. Write 0x87 to Register 0x058B (scrambling enabled, $L = 8$).
7. Write 0x01 to Register 0x058E ($M = 2$).
8. Write 0x00 to Register 0x058C ($F = 1$).
9. Write 0x00 to Register 0x056E (lane rate = 6.75 Gbps to 13.5 Gbps).
10. Write 0x14 to Register 0x0571 (JESD204B link power-up).
11. Wait 5 ms to 10 ms.
12. Read Register 0x056F (PLL status register).
13. Write 0x4F to Register 0x1228.
14. Write 0x0F to Register 0x1228.
15. Write 0x00 to Register 0x1222.
16. Write 0x04 to Register 0x1222.
17. Write 0x00 to Register 0x1222.
18. Write 0x08 to Register 0x1262.
19. Write 0x00 to Register 0x1262.

Example 2—ADC with DDC Option (Two ADCs Plus Two DDCs)

Figure 142. Two ADCs Plus Two DDCs Mode (L = 2, M = 4, F = 4, S = 1)

This example shows the flexibility in the digital and lane configurations for the AD9689. The sample rate is 2.4576 GSPS, whereas the outputs are all combined in a combination of either two, four, or eight lanes, depending on the input/output speed capability of the receiving device.

The AD9689 is set up as shown in Figure 142, with the following configuration:

- Two 14-bit converters at 2.4576 GSPS.
- Two DDC application layer mode with complex outputs (I/Q).
- Chip decimation ratio = 10.
- DDC decimation ratio = 10 (see Table 33).

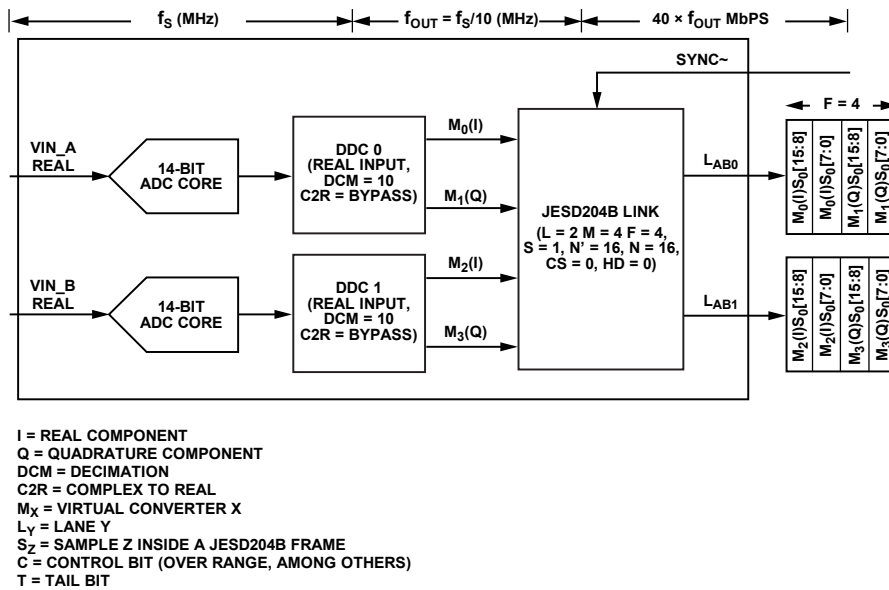
The JESD204B output configuration is as follows:

- Four virtual converters required (see Table 33).
- Output sample rate (f_{OUT}) = $2457.6/10 = 245.76$ MSPS.

The JESD204B supported output configurations are as follows (see Table 33):

- N' = 16 bits.
- N = 14 bits.
- L = 2, M = 4, and F = 4, or L = 4, M = 4, and F = 2.
- CS = 0.
- K = 32.
- Output serial lane rate = 9.8304 Gbps per lane (L = 2), 4.9152 Gbps per lane (L = 4), or 2.4576 Gbps per lane (L = 8).

For L = 2, set the PLL control register, Register 0x056E, to 0x00.

For L = 4, set the PLL control register, Register 0x056E, to 0x10.

For L = 8, set the PLL control register, Register 0x056E, to 0x50.

Set up the AD9689 in this mode using the following sequence:

1. Write 0x81 to Register 0x0000 (SPI soft reset).
2. Wait 5 ms to 10 ms.
3. Write 0x02 to Register 0x0200 (two DDC mode).
4. Write 0x06 to Register 0x0201 (chip decimation ratio = 10).
5. Write 0x47 to Register 0x0310 (6 dB gain, decimation ratio set by Register 0x0311, Bits[7:4]).
6. Write 0x20 to Register 0x0311 (decimate by 10, DDC0 inputs from Channel A).
7. Register 0x0316 to Register 0x031B is the DDC0 NCO tuning word.
8. Write 0x47 to Register 0x0330 (6 dB gain, decimation ratio set by Register 0x0331, Bits[7:4]).
9. Write 0x25 to Register 0x0331 (decimate by 10, DDC1 inputs from Channel B).
10. Register 0x0336 to Register 0x033B is the DDC0 NCO tuning word.
11. Write 0x15 to Register 0x0571 (JESD204B link power down).
12. Write 0x81 to Register 0x058B (scrambling enabled, L = 2).
13. Write 0x03 to Register 0x058E (M = 4).
14. Write 0x03 to Register 0x058C (F = 4).
15. Write 0x00 to Register 0x056E (lane rate = 6.75 Gbps to 13.5 Gbps).
16. Write 0x14 to Register 0x0571 (JESD204B link power up).
17. Wait 5 ms to 10 ms.
18. Read Register 0x056F (PLL status register).
19. Write 0x4F to Register 0x1228.
20. Write 0x0F to Register 0x1228.
21. Write 0x00 to Register 0x1222.
22. Write 0x04 to Register 0x1222.
23. Write 0x00 to Register 0x1222.
24. Write 0x08 to Register 0x1262.
25. Write 0x00 to Register 0x1262.

DETERMINISTIC LATENCY

Both ends of the JESD204B link contain various clock domains distributed throughout each system. Data traversing from one clock domain to a different clock domain can lead to ambiguous delays in the JESD204B link. These ambiguities lead to non-repeatable latencies across the link from one power cycle or link reset to the next. Section 6 of the JESD204B specification addresses the issue of deterministic latency with mechanisms defined as Subclass 1 and Subclass 2.

The AD9689 supports JESD204B Subclass 0 and Subclass 1 operation. Register 0x0590, Bits[7:5] set the subclass mode for the AD9689 and its default is set for Subclass 1 operating mode (Register 0x0590, Bit 5 = 1). If deterministic latency is not a system requirement, Subclass 0 operation is recommended and the SYSREF signal may not be required. Even in Subclass 0 mode, the SYSREF signal may be required in an application where multiple AD9689 devices must be synchronized with each other. This topic is addressed in the Timestamp Mode section.

SUBCLASS 0 OPERATION

If there is no requirement for multichip synchronization while operating in Subclass 0 mode (Register 0x0590, Bits[7:5] = 0 decimal), the SYSREF input can be left disconnected. In this mode, the relationship of the JESD204B clocks between the JESD204B transmitter and receiver are arbitrary, but does not affect the ability of the receiver to capture and align the lanes within the link.

SUBCLASS 1 OPERATION

The JESD204B protocol organizes data samples into octets, frames, and multiframe as described in the Transport Layer section. The LMFC is synchronous with the beginnings of these multiframe. In Subclass 1 operation, the SYSREF signal synchronizes the LMFCs for each device in a link or across multiple links (within the AD9689, SYSREF also synchronizes the internal sample dividers), as shown in Figure 143. The JESD204B receiver uses the multiframe boundaries and buffering to achieve consistent latency across lanes (or even multiple devices), and to achieve a fixed latency between power cycles and link reset conditions.

Deterministic Latency Requirements

Several key factors are required for achieving deterministic latency in a JESD204B Subclass 1 system.

- SYSREF± signal distribution skew within the system must be less than the desired uncertainty for the system.
- SYSREF± setup and hold time requirements must be met for each device in the system.
- The total latency variation across all lanes, links, and devices must be ≤ 1 LMFC periods (see Figure 143). This includes both variable delays and the variation in fixed delays from lane to lane, link to link, and device to device in the system.

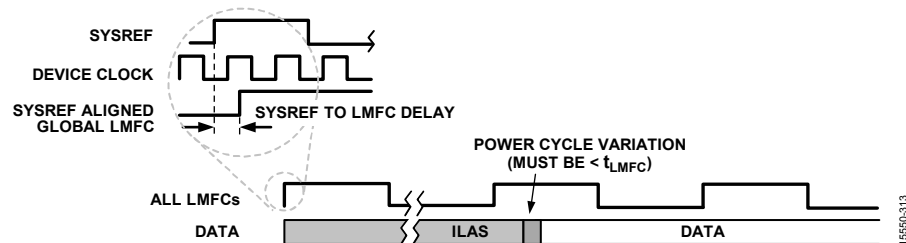

Figure 143. SYSREF and LMFC

Setting Deterministic Latency Registers

The JESD204B receiver in the logic device buffers data starting on the LMFC boundary. If the total link latency in the system is near an integer multiple of the LMFC period, it is possible that from one power cycle to the next, the data arrival time at the receive buffer may straddle an LMFC boundary. To ensure deterministic latency in this case, a phase adjustment of the LMFC at either the transmitter or receiver must be performed. Typically, adjustments to accommodate the receive buffer are made to the LMFC of the receiver. Alternatively, this adjustment can be made in the AD9689 using the LMFC offset register (Register 0x0578, Bits[4:0]). This adjustment delays the LMFC in frame clock increments, depending on the F parameter (number of octets per lane per frame). For F = 1, every fourth setting (0, 4, 8, and so on) is valid and results in a four frame clock shift. For F = 2, every other setting (0, 2, 4, and so on) is valid and results in a two-frame clock shift. For all other values of F, each setting results in a one-frame clock shift. Figure 144 shows that, when the link latency is near an LMFC boundary, the local LMFC of the AD9689 can be adjusted to delay the data arrival time at the receiver. Figure 145 shows how the LMFC of the receiver is delayed to accommodate the receive buffer

timing. Consult the applicable JESD204B receiver user guide for details on making this adjustment.

If the total latency in the system is not near an integer multiple of the LMFC period or if the appropriate adjustments have been made to the LMFC phase at the clock source, it is still possible to have variable latency from one power cycle to the next. By design, the AD9689 has circuitry in place to minimize this variation from power-up to power-up. In this case, the user must check for the possibility that the setup and hold time requirements for the SYSREF signal are not being met, by reading the SYSREF± setup/hold status bits (Register 0x0128). This function is fully described in the SYSREF± Setup/Hold Window Monitor section.

If reading Register 0x0128 indicates there may be a timing problem, a few adjustments can be made in the AD9689. Changing the SYSREF level that is used for alignment is possible using the SYSREF± transition select bit (Register 0x0120, Bit 4). Also, changing which edge of CLK± is used to capture SYSREF can be done using the CLK± edge select bit (Register 0x0120, Bit 3). Both of these options are described in the SYSREF Control Features section. If neither of these measures helps to achieve an acceptable setup and hold time, adjusting the phase of SYSREF and/or the device clock (CLK±) may be required.

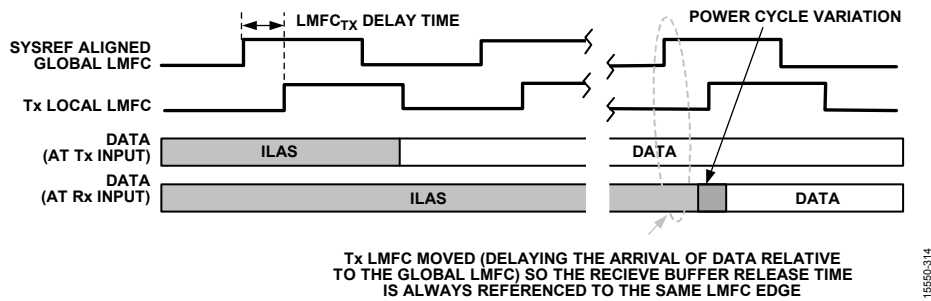

Figure 144. Adjusting the JESD204B Tx LMFC in the AD9689

15550-314

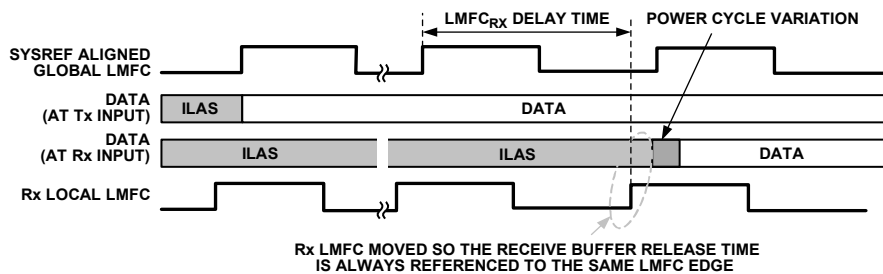

Figure 145. Adjusting the JESD204B Rx LMFC in the Logic Device

15550-315

MULTICHIP SYNCHRONIZATION

The flowchart in Figure 147 shows the internal mechanism for multichip synchronization in the AD9689. There are two methods by which multichip synchronization can take place, as determined by the synchronization mode bit (Register 0x01FF, Bit 0). Each method involves different applications of the SYSREF signal.

NORMAL MODE

The default state of the chip synchronization mode bit is 0, which configures the AD9689 for normal chip synchronization. The JESD204B standard specifies the use of SYSREF to provide for deterministic latency within a single link. This same concept, when applied to a system with multiple converters and logic devices, can also provide multichip synchronization referred to as normal mode (see Figure 147). Following the process in the flowchart ensures that the AD9689 is configured appropriately. The user must also consult the logic devices user IP guide to ensure that the JESD204B receivers are configured appropriately.

TIMESTAMP MODE

For all AD9689 full bandwidth operating modes, the SYSREF input can also be used to timestamp samples, another method by which multiple channels and multiple devices can achieve synchronization. This method is especially effective when synchronizing multiple devices to one or more logic devices. The logic devices buffer the data streams, identify the timestamped samples, and align them. When the synchronization mode bit (Register 0x01FF, Bit 0) is set to 1, the timestamp method is used for synchronization of multiple channels and/or devices.

In this mode, SYSREF resets the sample dividers and the JESD204B clocking. When the chip sync mode is set to 1, the clocks are not reset; instead, the coinciding sample is timestamped using the JESD204B control bits of that sample. To operate in timestamp mode, these additional settings are necessary:

- Continuous or N-shot SYSREF must be enabled (Register 0x0120, Bits[2:1] = 1 or 2 decimal).
- At least one control bit must be enabled (Register 0x058F, Bits[7:6] = 1, 2, or 3 decimal).
- Set the function for one of the control bits to SYSREF: Register 0x0559, Bits[3:0] = 5 decimal if using Control Bit 0, Register 0x0559, Bits[7:4] = 5 decimal if using Control Bit 1, Register 0x055A, Bits[3:0] = 5 decimal if using Control Bit 2.

Figure 146 shows how the input sample coincident with SYSREF is timestamped and ultimately output from the ADC. In this example, there are two control bits, and Control Bit 0 is the bit indicating which sample was coincident with the SYSREF rising edge. Note that the pipeline latencies for each channel are identical. If so desired, the SYSREF± timestamp delay register (Register 0x0123) can be used to adjust the timing of which sample is time stamped.

Note that time stamping is not supported by any AD9689 operating modes that use decimation.

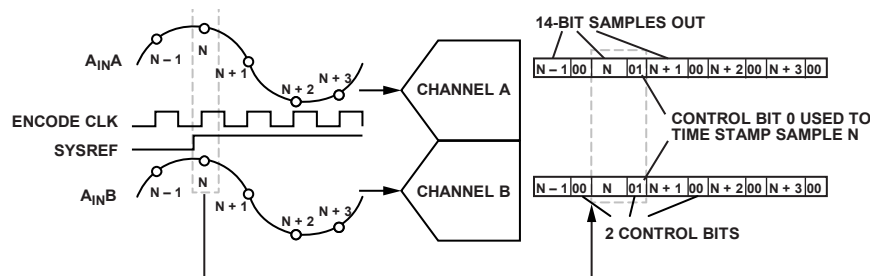

Figure 146. AD9689 Timestamping Example—CS = 2 (Register 0x058F, Bits[7:6] = 2 Decimal), Control Bit 0 is SYSREF (Register 0x0559, Bits[3:0] = 5 Decimal)

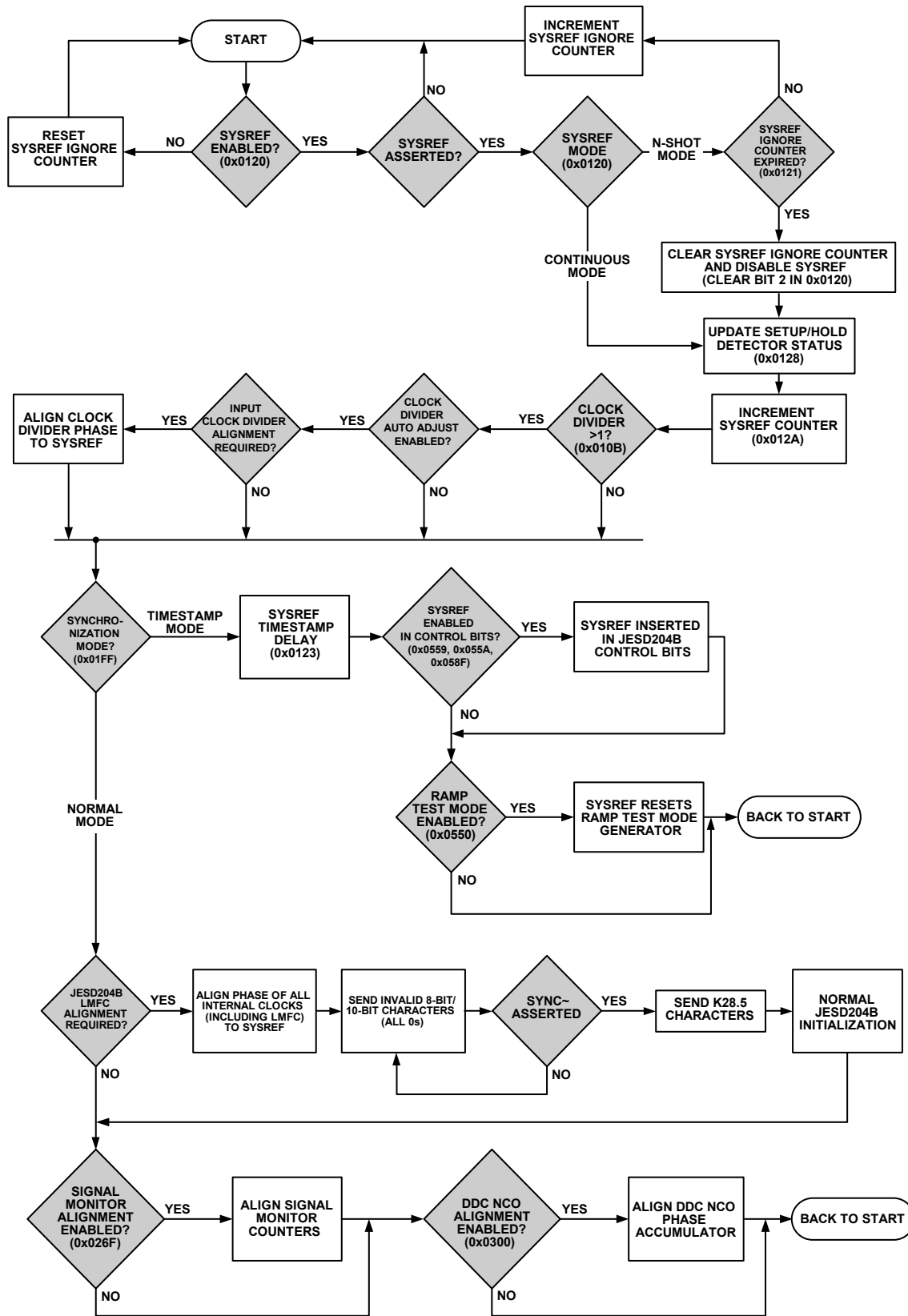

Figure 147. SYSREF Capture Scenarios and Multichip Synchronization

15550-317

SYSREF INPUT

The SYSREF input signal is used as a high accuracy system reference for deterministic latency and multichip synchronization. The AD9689 accepts a single-shot or periodic input signal. The SYSREF± mode select bits (Register 0x0120, Bits[2:1]) select the input signal type and arm the SYSREF state machine when set. If in single (or N) shot mode (Register 0x0120, Bits[2:1] = 2 decimal), the SYSREF± mode select bit self clears after the appropriate SYSREF transition is detected. The pulse width must have a minimum width of two CLK± periods. If the clock divider (Register 0x010B, Bits[3:0]) is set to a value other than divide by 1, multiply this minimum pulse width requirement by the divide ratio (that is, if set to divide by 8, the minimum pulse width is 16 CLK± cycles). When using a continuous SYSREF signal (Register 0x0120, Bits[2:1] = 1 decimal), the period of the SYSREF signal must be an integer multiple of the LMFC. LMFC can be derived using the following formula:

$$LMFC = ADC\ clock / (S \times K)$$

where:

S is the JESD204B parameter for number of samples per converter.
 K is the number of frames per multiframe.

The input clock divider, DDCs, signal monitor block, and JESD204B link are all synchronized using the SYSREF± input when in normal synchronization mode (Register 0x01FF, Bit 0 = 0). The SYSREF± input can also be used to timestamp an ADC sample to provide a mechanism for synchronizing multiple AD9689 devices in a system. For the highest level of timing accuracy, SYSREF± must meet setup and hold requirements relative to the CLK± input. There are several features in the AD9689 that can be used to ensure these requirements are met; these features are described in the SYSREF Control Features section.

SYSREF Control Features

SYSREF is used, along with the input clock (CLK), as part of a source-synchronous timing interface and requires setup and hold timing requirements of -65 ps and 95 ps relative to the input clock (see Figure 148). The AD9689 has several features that aid the user in meeting these requirements. First, the SYSREF sample event can be defined as either a synchronous low to high transition or synchronous high to low transition. Second, the AD9689 allows the SYSREF signal to be sampled using either the rising edge or falling edge of the input clock. Figure 148, Figure 149, Figure 150, and Figure 151 show all four possible combinations.

The third SYSREF related feature available is the ability to ignore a programmable number (up to 16) of SYSREF events.

The AD9689 is able to ignore N SYSREF events (note that the SYSREF ignore feature is enabled by setting the SYSREF± mode select bits (Register 0x0120, Bits[2:1]) to 2'b10, N-shot mode). This feature is useful for handling periodic SYSREF signals, which need time to settle after startup. Ignoring SYSREF until the clocks in the system have settled can avoid an inaccurate SYSREF trigger. Figure 152 shows an example of the SYSREF ignore feature when ignoring three SYSREF events.

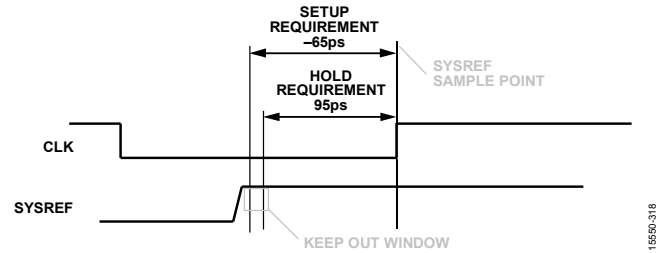

Figure 148. SYSREF Setup and Hold Time Requirements—SYSREF Low to High Transition Using Rising Edge Clock (Default)

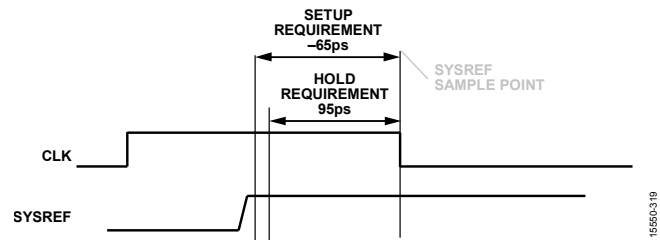

Figure 149. SYSREF Low to High Transition Using Falling Edge Clock Capture (Register 0x0120, Bit 4 = 1'b0; Register 0x0120, Bit 3 = 1'b1)

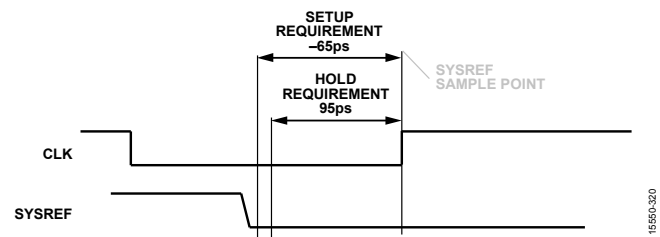

Figure 150. SYSREF High to Low Transition Using Rising Edge Clock Capture (Register 0x0120, Bit 4 = 1'b1; Register 0x0120, Bit 3 = 1'b0)

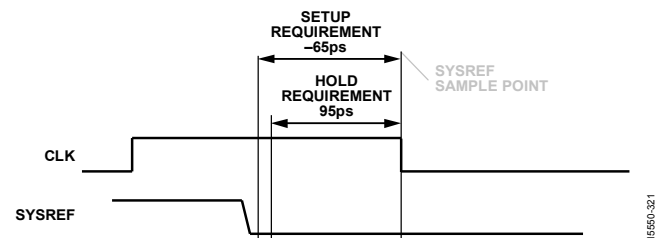

Figure 151. SYSREF High to Low Transition Using Falling Edge Clock Capture (Register 0x0120, Bit 4 = 1'b1; Register 0x0120, Bit 3 = 1'b1)

SYSREF± SETUP/HOLD WINDOW MONITOR

To ensure a valid SYSREF signal capture, the AD9689 has a SYSREF± setup/hold window monitor. This feature allows the system designer to determine the location of the SYSREF± signals relative to the CLK± signals by reading back the amount of setup/hold margin on the interface through the memory map. Figure 154 and Figure 155 show the setup and hold status values for different phases of SYSREF±.

The setup detector returns the status of the SYSREF± signal before the CLK± edge, and the hold detector returns the status of the SYSREF signal after the CLK± edge. Register 0x0128 stores the status of SYSREF± and notifies the user if the SYSREF± signal is captured by the ADC.

Table 36 shows the description of the contents of Register 0x0128 and how to interpret them.

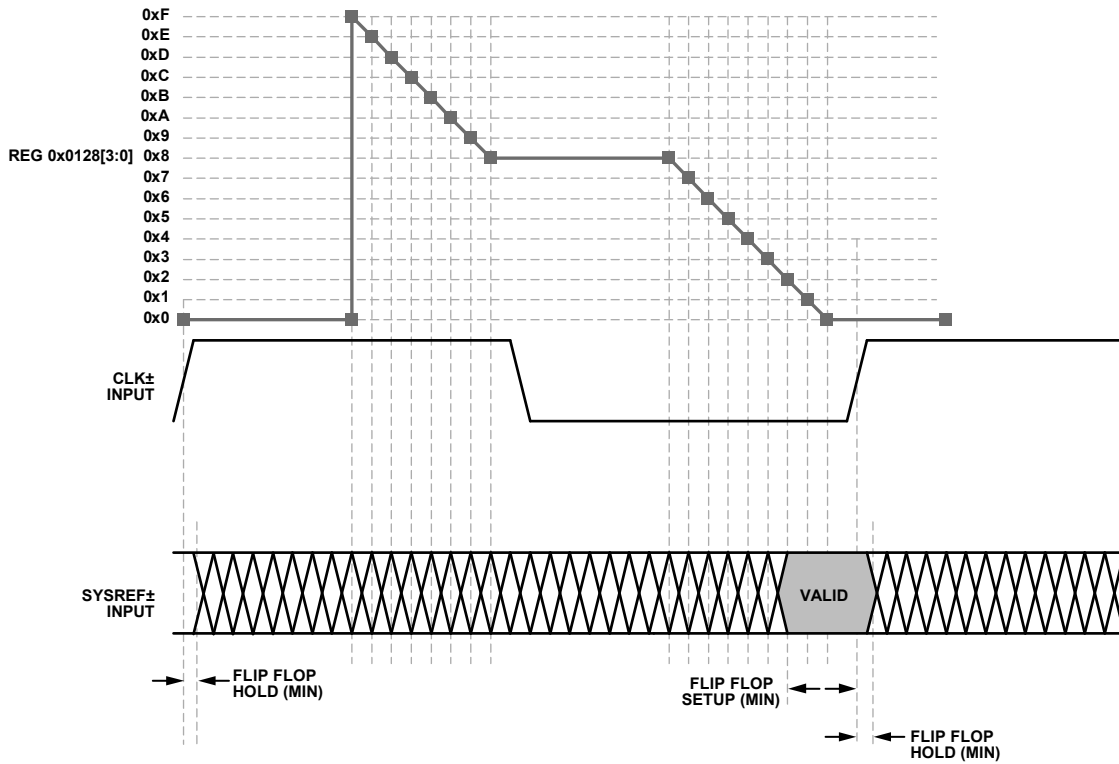

Figure 154. SYSREF± Setup Detector

15550-070

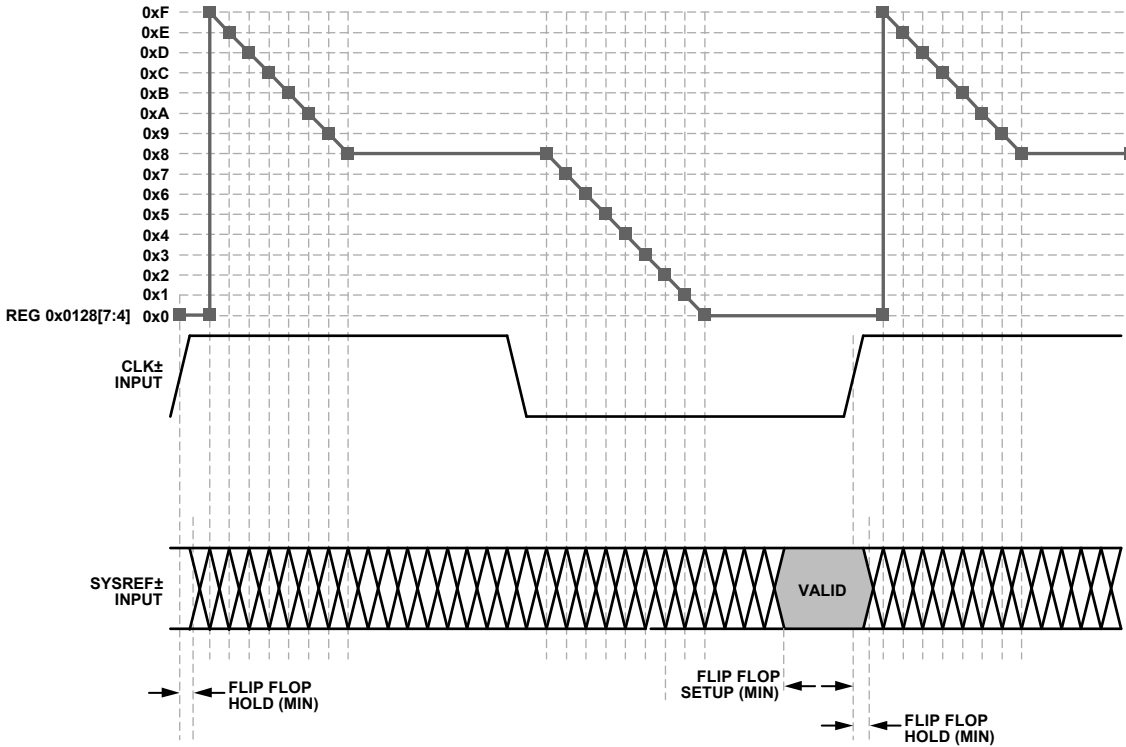

Figure 155. SYSREF± Hold Detector

19590-071

Table 36. SYSREF± Setup/Hold Monitor, Register 0x0128

Register 0x0128, Bits[7:4] Hold Status	Register 0x0128, Bits[3:0] Setup Status	Description
0x0	0x0 to 0x7	Possible setup error. The smaller this number, the smaller the setup margin.
0x0 to 0x8	0x8	No setup or hold error (best hold margin).
0x8	0x9 to 0xF	No setup or hold error (best setup and hold margin).
0x8	0x0	No setup or hold error (best setup margin).
0x9 to 0xF	0x0	Possible hold error. The larger this number, the smaller the hold margin.
0x0	0x0	Possible setup or hold error.

LATENCY

END TO END TOTAL LATENCY

Total latency in the AD9689 is dependent on the chip application mode and the JESD204B configuration. For any given combination of these parameters, the latency is deterministic; however, the value of this deterministic latency must be calculated as described in the Example Latency Calculations section.

Table 37 shows the combined latency through the ADC and digital signal processor (DSP) for the different chip application modes supported by the AD9689. Table 38 shows the latency through the JESD204B block for each application mode based on the M/L ratio. For Table 37 and Table 38, latency is typical and is in units of the encode clock. The latency through the JESD204B block does not depend on the output data type (real or complex). Therefore, data type is not included in Table 38.

To determine the total latency, select the appropriate ADC + DSP latency from Table 37 and add it to the appropriate JESD204B latency from Table 38. Example calculations are provided in the following section.

EXAMPLE LATENCY CALCULATIONS

Example Configuration 1 is as follows:

- ADC application mode = full bandwidth
- Real outputs
- $L = 8, M = 2, F = 1, S = 2$ (JESD204B mode)
- $20 \times (M/L) = 5$
- Latency = $31 + 44 = 75$ encode clocks

Example Configuration 2 is as follows:

- ADC application mode = DCM4
- Complex outputs
- $L = 4, M = 2, F = 1, S = 1$ (JESD204B mode)
- $20 \times (M/L) = 10$
- Latency = $162 + 88 = 250$ encode clocks

LMFC REFERENCED LATENCY

Some FPGA vendors may require the end user to know the LMFC referenced latency to make appropriate deterministic latency adjustments. If they are required, use the latency values in Table 37 and Table 38 for the analog in to LMFC and LMFC to data out latency values.

Table 37. Latency Through the ADC + DSP Blocks (Number of Sample Clocks)¹

Chip Application Mode	Enabled Filters	ADC + DSP Latency
Full Bandwidth	Not applicable	31
DCM1 (Real)	HB1	90
DCM2 (Complex)	HB1	90
DCM3 (Complex)	TB1	102
DCM2 (Real)	HB2 + HB1	162
DCM4 (Complex)	HB2 + HB1	162
DCM3 (Real)	TB2 + HB1	212
DCM6 (Complex)	TB2 + HB1	212
DCM4 (Real)	HB3 + HB2 + HB1	292
DCM8 (Complex)	HB3 + HB2 + HB1	292
DCM5 (Real)	FB2 + HB1	380
DCM10 (Complex)	FB2 + HB1	380
DCM6 (Real)	TB2 + HB2 + HB1	424
DCM12 (Complex)	TB2 + HB2 + HB1	424
DCM15 (Real)	FB2 + TB1	500
DCM8 (Real)	HB4 + HB3 + HB2 + HB1	552
DCM16 (Complex)	HB4 + HB3 + HB2 + HB1	552
DCM10 (Real)	FB2 + HB2 + HB1	694
DCM20 (Complex)	FB2 + HB2 + HB1	694
DCM12 (Real)	TB2 + HB3 + HB2 + HB1	814
DCM24 (Complex)	TB2 + HB3 + HB2 + HB1	814
DCM30 (Complex)	HB2 + FB2 + TB1	836
DCM20 (Real)	FB2 + HB3 + HB2 + HB1	1420
DCM40 (Complex)	FB2 + HB3 + HB2 + HB1	1420
DCM24 (Real)	TB2 + HB4 + HB3 + HB2 + HB1	1594
DCM48 (Complex)	TB2 + HB4 + HB3 + HB2 + HB1	1594

¹ DCMx indicates the decimation ratio.

Table 38. Latency Through JESD204B Block (Number of Sample Clocks)¹

Chip Application Mode	M/L Ratio ²						
	0.125	0.25	0.5	1	2	4	8
Full Bandwidth	82	44	25	14	7	9	3
DCM1	82	44	25	14	7	N/A	N/A
DCM2	160	84	46	27	14	7	N/A
DCM3	237	124	67	39	21	11	N/A
DCM4	315	164	88	50	27	14	9
DCM5	N/A	203 ³	109 ³	62 ³	43 ³	N/A	N/A
DCM6	N/A	243	130	73	39	21	14
DCM8	N/A	323	172	96	50	27	18
DCM10	N/A	N/A	213	119	62	33	22
DCM12	N/A	N/A	255	142	73	39	27
DCM15	N/A	N/A	318 ⁴	176 ⁴	90 ⁴	47 ⁴	33 ⁴
DCM16	N/A	N/A	339 ⁴	188 ⁴	96 ⁴	50 ⁴	35 ⁴
DCM20	N/A	N/A	N/A	233	119	62	43
DCM24	N/A	N/A	N/A	279	142	73	51
DCM30	N/A	N/A	N/A	348 ⁴	176 ⁴	90 ⁴	62 ⁴
DCM40	N/A	N/A	N/A	N/A	233 ⁴	119 ⁴	82 ⁴
DCM48	N/A	N/A	N/A	N/A	279 ⁴	142 ⁴	97 ⁴

¹ N/A means not applicable and indicates that the application mode is not supported at the M/L ratio listed.

² M/L ratio is the number of converters divided by the number of lanes for the configuration.

³ The application mode at the M/L ratio listed is only supported in real output mode.

⁴ The application mode at the M/L ratio listed is only supported in complex output mode.

TEST MODES

ADC TEST MODES

The AD9689 has various test options that aid in the system level implementation. The AD9689 has ADC test modes that are available in Register 0x0550. These test modes are described in Table 39. When an output test mode is enabled, the analog section of the ADC is disconnected from the digital back-end blocks, and the test pattern is run through the output formatting block. Some of the test patterns are subject to output formatting, and some are not. The pseudorandom number (PN) generators from the PN sequence tests can be reset by setting Bit 4 or Bit 5 of Register 0x0550. These tests can be performed with or without an analog signal (if present, the analog signal is ignored); however, they do require an encode clock.

If the application mode is set to select a DDC mode of operation, the test modes must be enabled for each DDC enabled. The test patterns can be enabled via Bit 2 and Bit 0 of Register 0x0327, Register 0x0347, and Register 0x0367, depending on which DDC(s) are selected. The (I) data uses the test patterns selected for Channel A, and the (Q) data uses the test patterns selected for Channel B. For DDC3 only, the (I) data uses the test patterns from Channel A, and the (Q) data does not output test patterns. Bit 0 of Register 0x0387 selects the Channel A test patterns to be used for the (I) data. For more information, see the [AN-877 Application Note](#).

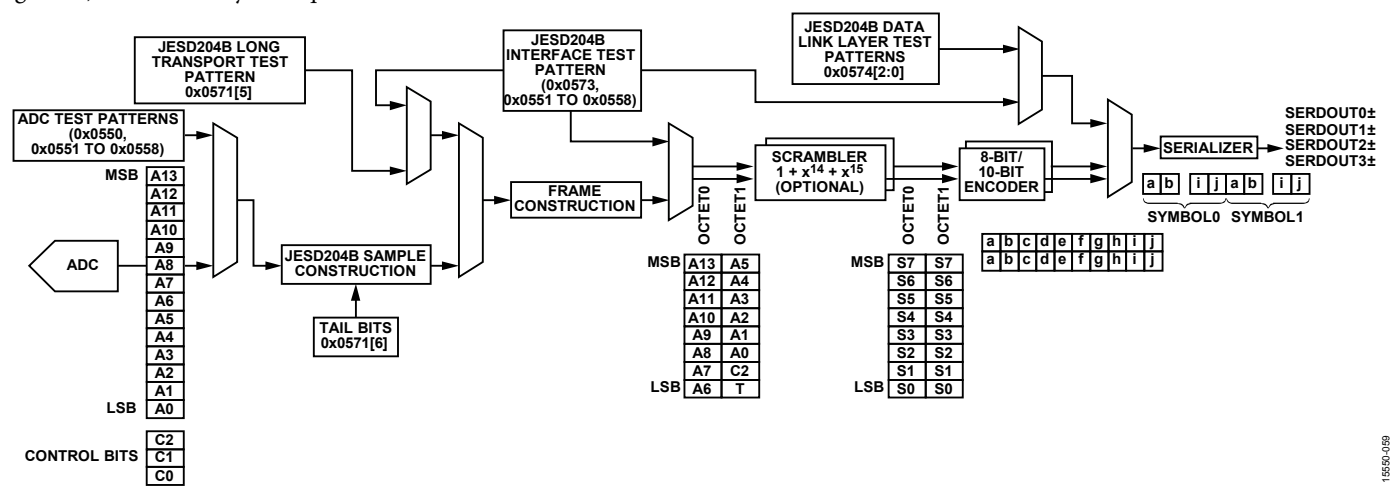

Figure 156. ADC Output Datapath Showing Test Pattern Injection Points

Table 39. ADC Test Modes

Output Test Mode Bit Sequence	Pattern Name	Expression	Default/Seed Value	Sample (N, N + 1, N + 2, ...)
0000	Off (default)	Not applicable	Not applicable	Not applicable
0001	Midscale short	0000 0000 0000	Not applicable	Not applicable
0010	Positive full-scale short	01 1111 1111 1111	Not applicable	Not applicable
0011	Negative full-scale short	10 0000 0000 0000	Not applicable	Not applicable
0100	Checkerboard	10 1010 1010 1010	Not applicable	0x1555, 0x2AAA, 0x1555, 0x2AAA, 0x1555
0101	PN sequence long	$x^{23} + x^{18} + 1$	0x3AFF	0x3FD7, 0x0002, 0x26E0, 0x0A3D, 0x1CA6
0110	PN sequence short	$x^9 + x^5 + 1$	0x0092	0x125B, 0x3C9A, 0x2660, 0x0c65, 0x0697
0111	One-/zero-word toggle	11 1111 1111 1111	Not applicable	0x0000, 0x3FFF, 0x0000, 0x3FFF, 0x0000
1000	User input	Register 0x0551 to Register 0x0558	Not applicable	User Pattern 1[15:2], User Pattern 2[15:2], User Pattern 3[15:2], User Pattern 4[15:2], User Pattern 1[15:2] ... for repeat mode User Pattern 1[15:2], User Pattern 2[15:2], User Pattern 3[15:2], User Pattern 4[15:2], 0x0000 ... for single mode
1111	Ramp output	$(x) \% 2^{14}$	Not applicable	$(x) \% 2^{14}, (x + 1) \% 2^{14}, (x + 2) \% 2^{14}, (x + 3) \% 2^{14}$

JESD204B BLOCK TEST MODES

In addition to the ADC pipeline test modes, the AD9689 also has flexible test modes in the JESD204B block. These test modes are listed in Register 0x0573 and Register 0x0574. These test patterns can be inserted at various points along the output datapath. These test insertion points are shown in Figure 156. Table 40 describes the various test modes available in the JESD204B block. For the AD9689, a transition from test modes (Register 0x0573 \neq 0x00) to normal mode (Register 0x0573 = 0x00) requires an SPI soft reset, which is done by writing 0x81 to Register 0x0000 (self cleared).

Transport Layer Sample Test Mode

The transport layer samples are implemented in the AD9689 as defined by Section 5.1.6.3 in the JEDEC JESD204B specification.

These tests are shown in Register 0x0571, Bit 5. The test pattern is equivalent to the raw samples from the ADC.

Interface Test Modes

The interface test modes are described in Register 0x0573, Bits[3:0]. These test modes are also explained in Table 40. The interface tests can be inserted at various points along the data. See Figure 156 for more information on the test insertion points. Register 0x0573, Bits[5:4] show where these tests are inserted.

Table 41, Table 42, and Table 43 show examples of some of the test modes when inserted at the JESD204B sample input, physical 10-bit input, and scrambler 8-bit input. UPx in Table 41 to Table 43 represent the user pattern control bits from the user register map.

Table 40. JESD204B Interface Test Modes

Output Test Mode Bit Sequence	Pattern Name	Expression	Default
0000	Off (default)	Not applicable	Not applicable
0001	Alternating checker board	0x5555, 0xAAAA, 0x5555, ...	Not applicable
0010	1/0 word toggle	0x0000, 0xFFFF, 0x0000, ...	Not applicable
0011	31-bit PN sequence	$x^{31} + x^{28} + 1$	0x0003AFFF
0100	23-bit PN sequence	$x^{23} + x^{18} + 1$	0x003AFF
0101	15-bit PN sequence	$x^{15} + x^{14} + 1$	0x03AF
0110	9-bit PN sequence	$x^9 + x^5 + 1$	0x092
0111	7-bit PN sequence	$x^7 + x^6 + 1$	0x07
1000	Ramp output	$(x) \% 2^{16}$	Ramp size depends on test insertion point
1110	Continuous/repeat user test	Register 0x0551 to Register 0x0558	User Pattern 1 to User Pattern 4, then repeat
1111	Single user test	Register 0x0551 to Register 0x0558	User Pattern 1 to User Pattern 4, then zeros

Table 41. JESD204B Sample Input for M = 2, S = 2, N' = 16 (Register 0x0573, Bits[5:4] = 2'b00)

Frame Number	Converter Number	Sample Number	Alternating Checkerboard	1/0 Word Toggle	Ramp	PN9	PN23	User Repeat	User Single
0	0	0	0x5555	0x0000	$(x) \% 2^{16}$	0x496F	0xFF5C	UP1[15:0]	UP1[15:0]
0	0	1	0x5555	0x0000	$(x) \% 2^{16}$	0x496F	0xFF5C	UP1[15:0]	UP1[15:0]
0	1	0	0x5555	0x0000	$(x) \% 2^{16}$	0x496F	0xFF5C	UP1[15:0]	UP1[15:0]
0	1	1	0x5555	0x0000	$(x) \% 2^{16}$	0x496F	0xFF5C	UP1[15:0]	UP1[15:0]
1	0	0	0xAAAA	0xFFFF	$(x + 1) \% 2^{16}$	0xC9A9	0x0029	UP2[15:0]	UP2[15:0]
1	0	1	0xAAAA	0xFFFF	$(x + 1) \% 2^{16}$	0xC9A9	0x0029	UP2[15:0]	UP2[15:0]
1	1	0	0xAAAA	0xFFFF	$(x + 1) \% 2^{16}$	0xC9A9	0x0029	UP2[15:0]	UP2[15:0]
1	1	1	0xAAAA	0xFFFF	$(x + 1) \% 2^{16}$	0xC9A9	0x0029	UP2[15:0]	UP2[15:0]
2	0	0	0x5555	0x0000	$(x + 2) \% 2^{16}$	0x980C	0xB80A	UP3[15:0]	UP3[15:0]
2	0	1	0x5555	0x0000	$(x + 2) \% 2^{16}$	0x980C	0xB80A	UP3[15:0]	UP3[15:0]
2	1	0	0x5555	0x0000	$(x + 2) \% 2^{16}$	0x980C	0xB80A	UP3[15:0]	UP3[15:0]
2	1	1	0x5555	0x0000	$(x + 2) \% 2^{16}$	0x980C	0xB80A	UP3[15:0]	UP3[15:0]
3	0	0	0xAAAA	0xFFFF	$(x + 3) \% 2^{16}$	0x651A	0x3D72	UP4[15:0]	UP4[15:0]
3	0	1	0xAAAA	0xFFFF	$(x + 3) \% 2^{16}$	0x651A	0x3D72	UP4[15:0]	UP4[15:0]
3	1	0	0xAAAA	0xFFFF	$(x + 3) \% 2^{16}$	0x651A	0x3D72	UP4[15:0]	UP4[15:0]
3	1	1	0xAAAA	0xFFFF	$(x + 3) \% 2^{16}$	0x651A	0x3D72	UP4[15:0]	UP4[15:0]
4	0	0	0x5555	0x0000	$(x + 4) \% 2^{16}$	0x5FD1	0x9B26	UP1[15:0]	0x0000
4	0	1	0x5555	0x0000	$(x + 4) \% 2^{16}$	0x5FD1	0x9B26	UP1[15:0]	0x0000
4	1	0	0x5555	0x0000	$(x + 4) \% 2^{16}$	0x5FD1	0x9B26	UP1[15:0]	0x0000
4	1	1	0x5555	0x0000	$(x + 4) \% 2^{16}$	0x5FD1	0x9B26	UP1[15:0]	0x0000

Table 42. Physical Layer 10-Bit Input (Register 0x0573, Bits[5:4] = 2'b01)

10-Bit Symbol Number	Alternating Checkerboard	1/0 Word Toggle	Ramp	PN9	PN23	User Repeat	User Single
0	0x155	0x000	$(x) \% 2^{10}$	0x125	0x3FD	UP1[15:6]	UP1[15:6]
1	0x2AA	0x3FF	$(x + 1) \% 2^{10}$	0x2FC	0x1C0	UP2[15:6]	UP2[15:6]
2	0x155	0x000	$(x + 2) \% 2^{10}$	0x26A	0x00A	UP3[15:6]	UP3[15:6]
3	0x2AA	0x3FF	$(x + 3) \% 2^{10}$	0x198	0x1B8	UP4[15:6]	UP4[15:6]
4	0x155	0x000	$(x + 4) \% 2^{10}$	0x031	0x028	UP1[15:6]	0x000
5	0x2AA	0x3FF	$(x + 5) \% 2^{10}$	0x251	0x3D7	UP2[15:6]	0x000
6	0x155	0x000	$(x + 6) \% 2^{10}$	0x297	0x0A6	UP3[15:6]	0x000
7	0x2AA	0x3FF	$(x + 7) \% 2^{10}$	0x3D1	0x326	UP4[15:6]	0x000
8	0x155	0x000	$(x + 8) \% 2^{10}$	0x18E	0x10F	UP1[15:6]	0x000
9	0x2AA	0x3FF	$(x + 9) \% 2^{10}$	0x2CB	0x3FD	UP2[15:6]	0x000
10	0x155	0x000	$(x + 10) \% 2^{10}$	0x0F1	0x31E	UP3[15:6]	0x000
11	0x2AA	0x3FF	$(x + 11) \% 2^{10}$	0x3DD	0x008	UP4[15:6]	0x000

Table 43. Scrambler 8-Bit Input (Register 0x0573, Bits[5:4] = 2'b10)

8-Bit Octet Number	Alternating Checkerboard	1/0 Word Toggle	Ramp	PN9	PN23	User Repeat	User Single
0	0x55	0x00	$(x) \% 2^8$	0x49	0xFF	UP1[15:9]	UP1[15:9]
1	0xAA	0xFF	$(x + 1) \% 2^8$	0x6F	0x5C	UP2[15:9]	UP2[15:9]
2	0x55	0x00	$(x + 2) \% 2^8$	0xC9	0x00	UP3[15:9]	UP3[15:9]
3	0xAA	0xFF	$(x + 3) \% 2^8$	0xA9	0x29	UP4[15:9]	UP4[15:9]
4	0x55	0x00	$(x + 4) \% 2^8$	0x98	0xB8	UP1[15:9]	0x00
5	0xAA	0xFF	$(x + 5) \% 2^8$	0x0C	0x0A	UP2[15:9]	0x00
6	0x55	0x00	$(x + 6) \% 2^8$	0x65	0x3D	UP3[15:9]	0x00
7	0xAA	0xFF	$(x + 7) \% 2^8$	0x1A	0x72	UP4[15:9]	0x00
8	0x55	0x00	$(x + 8) \% 2^8$	0x5F	0x9B	UP1[15:9]	0x00
9	0xAA	0xFF	$(x + 9) \% 2^8$	0xD1	0x26	UP2[15:9]	0x00
10	0x55	0x00	$(x + 10) \% 2^8$	0x63	0x43	UP3[15:9]	0x00
11	0xAA	0xFF	$(x + 11) \% 2^8$	0xAC	0xFF	UP4[15:9]	0x00

Data Link Layer Test Modes

The data link layer test modes are implemented in the AD9689 as defined by Section 5.3.3.8.2 in the JEDEC JESD204B specification. These tests are shown in Register 0x0574, Bits[2:0].

Test patterns inserted at this point are useful for verifying the functionality of the data link layer. When the data link layer test modes are enabled, disable SYNCINB± by writing 0xC0 to Register 0x0572.

SERIAL PORT INTERFACE

The AD9689 SPI allows the user to configure the converter for specific functions or operations through a structured register space provided inside the ADC. The SPI gives the user added flexibility and customization, depending on the application. Addresses are accessed via the serial port and can be written to or read from via the port. Memory is organized into bytes that can be further divided into fields. These fields are documented in the Memory Map section. For detailed operational information, see the [Serial Control Interface Standard \(Rev. 1.0\)](#).

CONFIGURATION USING THE SPI

Three pins define the SPI of the AD9689 ADC: the SCLK pin, the SDIO pin, and the CSB pin (see Table 44). The SCLK (serial clock) pin synchronizes the read and write data presented from/to the ADC. The SDIO (serial data input/output) pin is a dual-purpose pin that allows data to be sent and read from the internal ADC memory map registers. The CSB (chip select bar) pin is an active low control that enables or disables the read and write cycles.

Table 44. SPI Pins

Pin	Function
SCLK	Serial clock. The serial shift clock input that is used to synchronize serial interface, reads, and writes.
SDIO	Serial data input/output. A dual-purpose pin that typically serves as an input or an output, depending on the instruction being sent and the relative position in the timing frame.
CSB	Chip select bar. An active low control that gates the read and write cycles.

The falling edge of CSB, in conjunction with the rising edge of SCLK, determines the start of the framing. An example of the serial timing and its definitions can be found in Figure 4 and Table 5.

Other modes involving the CSB pin are available. The CSB pin can be held low indefinitely, which permanently enables the device; this is called streaming. The CSB can stall high between bytes to allow additional external timing. When CSB is tied high, SPI functions are placed in a high impedance mode. This mode turns on any SPI pin secondary functions.

All data is composed of 8-bit words. The first bit of each individual byte of serial data indicates whether a read or write

Table 45. Features Accessible Using the SPI

Feature	Description
Mode	Allows the user to set either power-down mode or standby mode.
Clock	Allows the user to access the clock divider via the SPI.
DDC	Allows the user to set up decimation filters for different applications.
Test Input/Output	Allows the user to set test modes to have known data on output bits.
Output Mode	Allows the user to set up outputs.
Serializer/Deserializer (SERDES) Output Setup	Allows the user to vary SERDES settings such as swing and emphasis.

command is issued, which allows the SDIO pin to change direction from an input to an output.

In addition to word length, the instruction phase determines whether the serial frame is a read or write operation, allowing the serial port to be used both to program the chip and to read the contents of the on-chip memory. If the instruction is a readback operation, performing a readback causes the SDIO pin to change direction from an input to an output at the appropriate point in the serial frame.

Data can be sent in MSB first mode or in LSB first mode. MSB first is the default on power-up and can be changed via the SPI port configuration register. For more information about this and other features, see the [Serial Control Interface Standard \(Rev. 1.0\)](#).

HARDWARE INTERFACE

The pins described in Table 44 comprise the physical interface between the user programming device and the serial port of the AD9689. The SCLK pin and the CSB pin function as inputs when using the SPI interface. The SDIO pin is bidirectional, functioning as an input during write phases and as an output during readback.

The SPI interface is flexible enough to be controlled by either FPGAs or microcontrollers. One method for SPI configuration is described in detail in the [AN-812 Application Note](#).

Do not activate the SPI port during periods when the full dynamic performance of the converter is required. Because the SCLK signal, the CSB signal, and the SDIO signal are typically asynchronous to the ADC clock, noise from these signals can degrade converter performance. If the on-board SPI bus is used for other devices, it may be necessary to provide buffers between this bus and the AD9689 to prevent these signals from transitioning at the converter inputs during critical sampling periods.

SPI ACCESSIBLE FEATURES

Table 45 provides a brief description of the general features that are accessible via the SPI. These features are described in detail in the [Serial Control Interface Standard \(Rev. 1.0\)](#). The AD9689 device specific features are described in the Memory Map section.

MEMORY MAP

READING THE MEMORY MAP REGISTER TABLE

Each address in the memory map register table has eight bit locations. The memory map is divided into the following sections:

- Analog Devices SPI registers (Register 0x0000 to Register 0x000F)
- Clock/SYSREF/chip power-down pin control registers (Register 0x003F to Register 0x01FF)
- Chip operating mode control registers (Register 0x0200 to Register 0x0201)
- Fast detect and signal monitor control registers (Register 0x0245 to Register 0x027A)
- DDC function registers (Register 0x0300 to Register 0x03CD)
- Digital outputs and test modes registers (Register 0x0550 to Register 0x05CB and Register 0x1222 to Register 0x01262)
- Programmable filter control and coefficients registers (Register 0x0DF8 to Register 0x0F7F)
- VREF/analog input control registers (Register 0x18A6 to Register 0x1A4D and Register 0x0701 to Register 0x073B)

The Memory Map Register Details section documents the default hexadecimal value for each hexadecimal address shown. For example, Address 0x0561, the output sample mode register, has a hexadecimal default value of 0x01, which means that Bit 0 = 1, and the remaining bits are 0s. This setting is the default output format value, which is twos complement. For more information on this function and others, see Table 46 to Table 53.

Open and Reserved Locations

All address and bit locations that are not included in Table 46 to Table 53 are not currently supported for this device. Write unused bits of a valid address location with 0s unless the default value is set otherwise. Writing to these locations is required only when part of an address location is unassigned (for example, Address 0x0561). If the entire address location is open (for example, Address 0x0013), do not write to this address location.

Default Values

After the AD9689 is reset, critical registers are loaded with default values. The default values for the registers are given in the memory map register tables, Table 46 to Table 53.

Logic Levels

An explanation of logic level terminology follows:

- “Bit is set” is synonymous with “bit is set to Logic 1” or “writing Logic 1 for the bit.”
- “Clear a bit” is synonymous with “bit is set to Logic 0” or “writing Logic 0 for the bit.”
- X denotes a don't care bit.

Channel Specific Registers

Some channel setup functions, such as the buffer control register (Register 0x1A4C), can be programmed to a different value for each channel. In these cases, channel address locations are internally duplicated for each channel. These registers and bits are designated as local. These local registers and bits can be accessed by setting the appropriate Channel A or Channel B bits in Register 0x0008. If both bits are set, the subsequent write affects the registers of both channels. In a read cycle, set only Channel A or Channel B to read one of the two registers. If both bits are set during an SPI read cycle, the device returns the value for Channel A. All other registers and bits are considered global, and changes to these registers and bits affect the entire device and the channel features for which independent settings are not allowed between channels. The settings in Register 0x0005 do not affect the global registers and bits.

SPI Soft Reset

After issuing a soft reset by programming 0x81 to Register 0x0000, the AD9689 requires 5 ms to recover. When programming the AD9689 for application setup, ensure that an adequate delay is programmed into the firmware after asserting the soft reset and before starting the device setup.

MEMORY MAP REGISTER DETAILS

All address locations that are not included in Table 46 to Table 53 are not currently supported for this device and must not be written.

Analog Devices SPI Registers

Table 46.

Addr.	Name	Bit(s)	Bit Name	Setting	Description	Reset	Access
0x0000	SPI Configuration A	7	Soft reset mirror (self clearing)	0 1	Whenever a soft reset is issued, the user must wait 5 ms before writing to any other register, to provide sufficient time for the boot loader to complete. Do nothing. Reset the SPI and registers (self clearing).	0x0	R/WC
		6	LSB first mirror	1 0	Least significant bit shifted first for all SPI operations. Most significant bit shifted first for all SPI operations.	0x0	R/W
		5	Address ascension mirror	0 1	Multibyte SPI operations cause addresses to auto-decrement. Multibyte SPI operations cause addresses to auto-increment.	0x0	R/W
		[4:3]	Reserved		Reserved.	0x0	R
		2	Address ascension	0 1	Multibyte SPI operations cause addresses to auto-decrement. Multibyte SPI operations cause addresses to auto-increment.	0x0	R/W
		1	LSB first	1 0	Least significant bit shifted first for all SPI operations. Most significant bit shifted first for all SPI operations.	0x0	R/W
		0	Soft reset (self clearing)	0 1	Whenever a soft reset is issued, the user must wait 5 ms before writing to any other register, to provide sufficient time for the boot loader to complete. Do nothing. Reset the SPI and registers (self clearing).	0x0	R/WC
0x0001	SPI Configuration B	[7:2]	Reserved		Reserved.	0x0	R
		1	Datapath soft reset (self clearing)	0 1	Normal operation. Datapath soft reset (self clearing).	0x0	R/WC
		0	Reserved		Reserved.	0x0	R
0x0002	Chip configuration (local)	[7:2]	Reserved		Reserved.	0x0	R
		[1:0]	Channel power mode	00 10 11	Channel power modes. Normal mode (power-up). Standby mode; digital datapath clocks disabled; JESD204B interface enabled. Power-down mode; digital datapath clocks disabled; digital datapath held in reset; JESD204B interface disabled.	0x0	R/W
0x0003	Chip type	[7:0]	Chip type	0x3	Chip type. High speed ADC.	0x03	R
0x0004	Chip ID LSB	[7:0]	Chip ID LSB[7:0]	0xD9	Chip ID. AD9689.	0xE2	R
0x0005	Chip ID MSB	[7:0]	Chip ID MSB[15:8]		Chip ID.	0x0	R
0x0006	Chip grade		Chip speed grade	0x0 0x1	Chip speed grade. 2.6 GSPS. 2.0 GSPS.	0x0	R
		[3:0]	Reserved		Reserved.	0x0	R
0x0008	Device index	[7:2]	Reserved		Reserved.	0x0	R
		1	Channel B	0 1	ADC Core B does not receive the next SPI command. ADC Core B receives the next SPI command.	0x1	R/W
		0	Channel A	0 1	ADC Core A does not receive the next SPI command. ADC Core A receives the next SPI command.	0x1	R/W

Addr.	Name	Bit(s)	Bit Name	Setting	Description	Reset	Access
0x000A	Scratch pad	[7:0]	Scratch pad		Chip scratch pad register. This register is used to provide a consistent memory location for software debug.	0x0	R/W
0x000B	SPI revision	[7:0]	SPI revision	00000001	SPI revision register. 0x01: Revision 1.0. Revision 1.0.	0x1	R
0x000C	Vendor ID LSB	[7:0]	Vendor ID LSB		Vendor ID[7:0].	0x56	R
0x000D	Vendor ID MSB	[7:0]	Vendor ID MSB		Vendor ID[15:8].	0x04	R
0x000F	Transfer	[7:1]	Reserved		Reserved.	0x0	R
		0	Chip transfer	0 1	Self clearing chip transfer bit. This bit is used to update the DDC FTW/POW/MAW/MBW increment and phase offset registers when DDC phase update mode (Register 0x0300, Bit 7) = 1, which makes it possible to synchronously update the DDC mixer frequencies. This bit is also used to update the coefficients for the programmable filter (PFILT). Do nothing. Bit is only cleared after transfer is complete. Self clearing bit used to synchronize the transfer of data from master to slave registers.	0x0	R/W

Clock/SYSREF/Chip Power-Down Pin Control Registers

Table 47.

Addr.	Name	Bit(s)	Bit Name	Setting	Description	Reset	Access	
0x003F	Chip PDWN pin (local)	7	Local chip PDWN pin disable	0	Power-down pin (PDWN/STBY) enabled (default).	0x0	R/W	
				1	Power-down pin (PDWN/STBY) disabled/ignored.			
		[6:0]	Reserved		Reserved.	0x0	R	
0x0040	Chip Pin Control 1	[7:6]	Chip PDWN pin functionality	00	External power-down pin functionality. Assertion of the external power-down pin (PDWN/STBY) has higher priority than the channel power mode bits (Register 0x0002, Bits[1:0]). The PDWN/STBY pin is only used when Register 0x0040, Bits[7:6] = 00 or 01. Power-down pin (default). Assertion of external power-down pin (PDWN/STBY) causes the chip to enter full power-down mode.	0x0	R/W	
				01	Standby pin. Assertion of external power-down pin (PDWN/STBY) causes the chip to enter standby mode.			
				10	Pin disabled. Power-down pin (PDWN/STBY) is ignored.			
			[5:3]	Chip FD_B/GPIO_B0 pin functionality	000 001 110 111	Fast Detect B/GPIO B0 pin functionality. Fast Detect B output. JESD204B LMFC output. Pin functionality determined by Register 0x0041, Bits[7:4]. Disabled. Configured as input with weak pull-down (default).	0x7	R/W
			[2:0]	Chip FD_A/GPIO_A0 pin functionality	000 001 110 111	Fast Detect A/GPIO A0 pin functionality. Fast Detect A output. JESD204B LMFC output. Pin functionality determined by Register 0x0041, Bits[3:0]. Disabled. Configured as an input with weak pull-down (default).	0x7	R/W
0x0041	Chip Pin Control 2	[7:4]	Chip FD_B/GPIO_B0 pin secondary functionality	0000 0001 1000 1001	Fast Detect B/GPIO B0 pin secondary functionality (only used when Register 0x0040, Bits[5:3] = 110). Chip GPIO B0 input (NCO channel selection). Chip transfer input. Master next trigger output (MNTO). Slave next trigger input (SNTI).	0x0	R/W	
			[3:0]	Chip FD_A/GPIO_A0 pin secondary functionality	0000 0001 1000 1001	Fast Detect A/GPIO B0 pin secondary functionality (only used when Register 0x0040, Bits[2:0] = 110). Chip GPIO A0 input (NCO channel selection). Chip transfer input. Master next trigger output (MNTO). Slave next trigger input (SNTI).	0x0	R/W

Addr.	Name	Bit(s)	Bit Name	Setting	Description	Reset	Access
0x0042	Chip Pin Control 3	[7:4]	Chip GPIO_B1 pin functionality	0000 1000 1001 1111	GPIO B1 pin functionality. Chip GPIO B1 input (NCO channel selection). Master next trigger output (MNTO). Slave next trigger input (SNTI). Disabled (configured as input with weak pull-down).	0xF	R/W
		[3:0]	Chip GPIO_B1 pin functionality	0000 1000 1001 1111	GPIO A1 pin functionality. Chip GPIO A1 input (NCO channel selection). Master next trigger output (MNTO). Slave next trigger input (SNTI). Disabled (configured as input with weak pull-down).		
0x0108	Clock divider control	[7:3]	Reserved		Reserved.	0x0	R
		[2:0]	Input clock divider (CLK± pins)	00 01 11	Divide by 1. Divide by 2. Divide by 4.	0x0	R/W
0x0109	Clock divider phase (local)	[7:4]	Reserved		Reserved.	0x0	R
		[3:0]	Clock divider phase offset	0000 0001 0010 ... 1110 1111	0 input clock cycles delayed. ½ input clock cycles delayed (invert clock). 1 input clock cycles delayed. ... 7 input clock cycles delayed. 7½ input clock cycles delayed.	0x0	R/W
0x010A	Clock divider and SYSREF control	7	Clock divider auto phase adjust enable	0 1	Clock divider auto phase adjust enable. When enabled, Register 0x0129, Bits[3:0] contain the phase of the divider when SYSREF was captured. The actual divider phase offset = Register 0x0129, Bits[3:0] + Register 0x0109, Bits[3:0]. Clock divider phase is not changed by SYSREF (disabled). Clock divider phase is automatically adjusted by SYSREF (enabled).	0x0	R/W
		[6:4]	Reserved		Reserved.	0x0	R
		[3:2]	Clock divider negative skew window	00 01 10 11	Clock divider negative skew window (measured in ½ input device clocks). Number of ½ clock cycles before the input device clock by which captured SYSREF transitions are ignored. Only used when Register 0x010A, Bit 7 = 1. Register 0x010A, Bits[3:2] + Register 0x010A, Bits[1:0] < Register 0x0108, Bits[2:0]. The skew allows some uncertainty in the sampling of SYSREF without disturbing the input clock divider. Also, SYSREF must be disabled (Register 0x0120, Bits[2:1] = 0x0) when changing this control field. No negative skew; SYSREF must be captured accurately. ½ device clock of negative skew. 1 device clocks of negative skew. 1½ device clocks of negative skew.	0x0	R/W
[1:0]	Clock divider positive skew window	00 01 10 11	Clock divider positive skew window (measured in ½ input device clocks). Number of clock cycles after the input device clock by which captured SYSREF transitions are ignored. Only used when Register 0x010A, Bit 7 = 1. Register 0x010A, Bits[3:2] + Register 0x010A, Bits[1:0] < Register 0x0108, Bits[2:0]. The skew allows some uncertainty in the sampling of SYSREF without disturbing the input clock divider. Also, SYSREF must be disabled (Register 0x0120, Bits[2:1] = 0x0) when changing this control field. No positive skew; SYSREF must be captured accurately. ½ device clock of positive skew. 1 device clocks of positive skew. 1½ device clocks of positive skew.	0x0	R/W		

Addr.	Name	Bit(s)	Bit Name	Setting	Description	Reset	Access
0x010B	Clock divider SYSREF status	[7:4]	Reserved		Reserved.	0x0	R
		[3:0]	Clock divider SYSREF offset		Clock divider phase status (measured in ½ clock cycles). Internal clock divider phase of the captured SYSREF signal applied to the phase offset. Only used when Register 0x010A, Bit 7 = 1. When Register 0x010A, Bit 7 = 1 and Register 0x010A, Bits[3:2] = 0 decimal and Register 0x010A, Bits[1:0] = 0 decimal, clock divider SYSREF offset = Register 0x0129, Bits[3:0].	0x0	R
0x0110	Clock delay control	[7:3]	Reserved		Reserved.	0x0	R
		[2:0]	Clock delay mode select	000 010 011 100 110	Clock delay mode select. Used in conjunction with Register 0x0111 and Register 0x0112. No clock delay. Fine delay: only 0 to 16 delay steps are valid. Fine delay (lowest jitter): only 0 to 16 delay steps are valid. Fine delay: all 192 delay steps are valid. Fine delay enabled (all 192 delay steps are valid); super fine delay enabled (all 128 delay steps are valid).	0x0	R/W
0x0111	Clock super fine delay (local)	[7:0]	Clock super fine delay adjust	0x00 ... 0x08 ... 0x80	Clock super fine delay adjust. This is an unsigned control to adjust the super fine sample clock delay in 0.25 ps steps. These bits are only used when Register 0x0110, Bits[2:0] = 010 or 110. 0 delay steps. ... 8 delay steps. ... 128 delay steps.	0x0	R/W
0x0112	Clock fine delay (local)	[7:0]	Set clock fine delay	0x00 ... 0x08 ... 0xC0	Clock fine delay adjust. This is an unsigned control to adjust the fine sample clock skew in 1.725 ps steps. These bits are only used when Register 0x0110, Bits[2:0] = 0x2, 0x3, 0x4, or 0x6. Minimum = 0. Maximum = 192. Increment = 1. Unit is delay steps. 0 delay steps. ... 8 delay steps. ... 192 delay steps.	0xC0	R/W
0x011B	Clock status	[7:1]	Reserved		Reserved.	0x0	R
		0	Input clock detect	0 1	Clock detection status. Input clock not detected. Input clock detected/locked.	0x0	R
0x011C	Clock Duty Cycle Stabilizer 1 control (local)	[7:2]	Reserved		Reserved.	0x0	R/W
		1	DCS1 enable	0 1	Clock DCS1 enable. DCS1 bypassed. DCS1 enabled.	0x1	R/W
		0	DCS1 power up	0 1	Clock DCS1 power-up. DCS1 powered down. DCS1 powered up.	0x1	R/W
0x011E	Clock Duty Cycle Stabilizer 2 control	[7:2]	Reserved		Reserved.	0x0	R/W
		1	DCS2 enable	0 1	Clock DCS2 enable. DCS2 bypassed. DCS2 enabled.	0x1	R/W
		0	DCS2 power up	0 1	Clock DCS2 power-up. DCS2 powered down. DCS2 powered up.	0x1	R/W

Addr.	Name	Bit(s)	Bit Name	Setting	Description	Reset	Access
0x0120	SYSREF Control 1	7	Reserved		Reserved.	0x0	R
		6	SYSREF± flag reset	0 1	Normal flag operation. SYSREF± flags held in reset (setup/hold error flags cleared).	0x0	R/W
		5	Reserved		Reserved.	0x0	R
		4	SYSREF± transition select	0 1	SYSREF± is valid on low to high transitions using the selected CLK± edge. When changing this setting, SYSREF± mode select must be set to disabled. SYSREF± is valid on high to low transitions using the selected CLK± edge. When changing this setting, SYSREF± mode select must be set to disabled.	0x0	R/W
		3	CLK± edge select	00 01	Captured on the rising edge of CLK± input. Captured on the falling edge of CLK± input.	0x0	R/W
		[2:1]	SYSREF± mode select	0 1 10	Disabled. Continuous. N-shot.	0x0	R/W
		0	Reserved		Reserved.	0x0	R
		0x0121	SYSREF Control 2	[7:4]	Reserved		Reserved.
		[3:0]	SYSREF N-shot ignore counter select	0000 0001 0010 0011 ... 1110 1111	Next SYSREF± transition only (do not ignore). Ignore the first SYSREF± transition. Ignore the first two SYSREF± transitions. Ignore the first three SYSREF± transitions. ... Ignore the first 14 SYSREF± transitions. Ignore the first 15 SYSREF± transitions.	0x0	R/W
0x0122	SYSREF Control 3	[7:4]	Reserved		Reserved.	0x0	R
		[3:2]	SYSREF window negative	00 01 10 11	Negative skew window (measured in sample clocks). Number of clock cycles before the sample clock by which captured SYSREF transitions are ignored. No negative skew; SYSREF must be captured accurately. One sample clock of negative skew. Two sample clocks of negative skew. Three sample clocks of negative skew.	0x0	R/W
		[1:0]	SYSREF window positive	00 01 10 11	Positive skew window (measured in sample clocks). Number of clock cycles before the sample clock by which captured SYSREF transitions are ignored. No positive skew; SYSREF must be captured accurately. One sample clock of positive skew. Two sample clocks of positive skew. Three sample clocks of positive skew.	0x0	R/W
		7	Reserved		Reserved.	0x0	R
0x0123	SYSREF Control 4	[6:0]	SYSREF± timestamp delay, Bits[6:0]	0 1 ... 111 1111	SYSREF± timestamp delay (in converter sample clock cycles). 0 sample clock cycle delay. 1 sample clock cycle delay. ... 127 sample clock cycle delay.	0x00	R/W
		7	Reserved		Reserved.	0x0	R
0x0128	SYSREF Status 1	[7:4]	SYSREF± hold status		SYSREF± hold status.	0x0	R
		[3:0]	SYSREF± setup status		SYSREF± setup status.	0x0	R

Addr.	Name	Bit(s)	Bit Name	Setting	Description	Reset	Access
0x0129	SYSREF Status 2	[7:4]	Reserved		Reserved.	0x0	R
		[3:0]	Clock divider phase when SYSREF± was captured	0000 0001 0010 0011 0100 ... 1111	SYSREF divider phase. Represents the phase of the divider when SYSREF± was captured. In phase. SYSREF± is ½ cycle delayed from clock. SYSREF± is 1 cycle delayed from clock. SYSREF± is 1½ input clock cycles delayed. SYSREF± is 2 input clock cycles delayed. ... SYSREF± is 7½ input clock cycles delayed.	0x0	R
0x012A	SYSREF Status 3	[7:0]	SYSREF counter, Bits[7:0] increments when a SYSREF± is captured		SYSREF count. Running counter that increments whenever a SYSREF± event is captured. Reset by Register 0x0120, Bit 6. Wraps around at 255. Read these bits only when Register 0x0120, Bits[2:1] are set to disabled.	0x0	R
0x01FF	Chip sync mode	[7:1]	Reserved		Reserved.	0x0	R
		0	Synchronization mode	0 1	JESD204B synchronization mode. The SYSREF signal resets all internal clock dividers. Use this mode when synchronizing multiple chips as specified in the JESD204B standard. If the phase of any of the dividers must change, the JESD204B link goes down. Timestamp mode. The SYSREF signal does not reset internal clock dividers. In this mode, the JESD204B link and the signal monitor are not affected by the SYSREF signal. The SYSREF signal timestamps a sample when it passes through the ADC and is used as a control bit in the JESD204B output word.	0x0	R/W

Chip Operating Mode Control Registers

Table 48.

Addr.	Name	Bit(s)	Bit Name	Setting	Description	Reset	Access
0x0200	Chip mode	[7:6]	Reserved		Reserved.	0x0	R/W
		5	Chip Q ignore	0	Chip real (I) only selection.	0x0	R/W
				1	Both real (I) and complex (Q) selected.		
				1	Only real (I) selected; complex (Q) is ignored.		
4	Reserved		Reserved.	0x0	R		
[3:0]	Chip application mode	0000	Full bandwidth mode (default).	0x0	R/W		
		0001	One DDC mode (DDC0 only).				
0x0201	Chip decimation ratio	[7:4]	Reserved		Reserved.	0x0	R
		[3:0]	Chip decimation ratio	0000 0001 1000 0010 0101 1001 0011 0110 1010 0111 0100 1101 1011 1110 1111 1100	Chip decimation ratio. Full sample rate (decimate by 1, DDCs are bypassed). Decimate by 2. Decimate by 3. Decimate by 4. Decimate by 5. Decimate by 6. Decimate by 8. Decimate by 10. Decimate by 12. Decimate by 15. Decimate by 16. Decimate by 20. Decimate by 24. Decimate by 30. Decimate by 40. Decimate by 48.	0x0	R/W

Fast Detect and Signal Monitor Control Registers

Table 49.

Addr.	Name	Bit(s)	Bit Name	Setting	Description	Reset	Access
0x0245	Fast detect control (local)	[7:4]	Reserved		Reserved.	0x0	R
		3	Force FD_A/FD_B pins	0 1	Normal operation of the fast detect pin. Force a value on the fast detect pin (see Bit 2).	0x0	R/W
		2	Force value of FD_A/FD_B pins		The fast detect output pin for this channel is set to this value when the output is forced.	0x0	R/W
		1	Reserved		Reserved.	0x0	R
		0	Enable fast detect output	0 1	Fast detect disabled. Fast detect enabled.	0x0	R/W
0x0247	Fast detect up LSB (local)	[7:0]	Fast detect upper threshold		LSBs of fast detect upper threshold. This register contains the 8 LSBs of the programmable 13-bit upper threshold that is compared to the fine ADC magnitude.	0x0	R/W
0x0248	Fast detect up MSB (local)	[7:5]	Reserved		Reserved.	0x0	R
		[4:0]	Fast detect upper threshold		LSBs of fast detect upper threshold. This register contains the 8 LSBs of the programmable 13-bit upper threshold that is compared to the fine ADC magnitude.	0x0	R/W
0x0249	Fast detect low LSB (local)	[7:0]	Fast detect lower threshold		LSBs of fast detect lower threshold. This register contains the 8 LSBs of the programmable 13-bit lower threshold that is compared to the fine ADC magnitude.	0x0	R/W
0x024A	Fast detect low MSB (local)	[7:5]	Reserved		Reserved.	0x0	R
		[4:0]	Fast detect lower threshold		LSBs of fast detect lower threshold. This register contains the 8 LSBs of the programmable 13-bit lower threshold that is compared to the fine ADC magnitude.	0x0	R/W
0x024B	Fast detect dwell LSB (local)	[7:0]	Fast detect dwell time		LSBs of fast detect dwell time counter target. This is a load value for a 16-bit counter that determines how long the ADC data must remain below the lower threshold before the FD_x pins are reset to 0.	0x0	R/W
0x024C	Fast detect dwell MSB (local)	[7:0]	Fast detect dwell time		LSBs of fast detect dwell time counter target. This is a load value for a 16-bit counter that determines how long the ADC data must remain below the lower threshold before the FD_x pins are reset to 0.	0x0	R/W
0x026F	Signal monitor sync control	[7:2]	Reserved		Reserved.	0x0	R
		1	Signal monitor next synchronization mode	0 1	Signal monitor next synchronization mode. Continuous mode. Next synchronization mode. Only the next valid edge of the SYSREF± pin is used to synchronize the signal monitor block. Subsequent edges of the SYSREF± pin are ignored. When the next SYSREF has been captured, Register 0x026F, Bit 0 is cleared. The SYSREF± pin must be an integer multiple of the signal monitor period for this function to operate correctly in continuous mode.	0x0	R/W
		0	Signal monitor synchronization mode	0 1	Signal monitor synchronization enable. Synchronization disabled. If Register 0x026F, Bit 1 = 1, only the next valid edge of the SYSREF± pin is used to synchronize the signal monitor block. Subsequent edges of the SYSREF± pin are ignored. When the next SYSREF signal is received, this bit is cleared. The SYSREF± input pin must be enabled to synchronize the signal monitor blocks.	0x0	R/W
0x0270	Signal monitor control (local)	[7:2]	Reserved		Reserved.	0x0	R
		1	Peak detector	0 1	Peak detector disabled. Peak detector enabled.	0x0	R/W
		0	Reserved		Reserved.	0x0	R

Addr.	Name	Bit(s)	Bit Name	Setting	Description	Reset	Access
0x0271	Signal Monitor Period 0 (local)	[7:0]	Signal monitor period[7:0]		Bits[7:0] of the 24-bit value that sets the number of output clock cycles over which the signal monitor performs its operation. Only even values are supported.	0x80	R/W
0x0272	Signal Monitor Period 1 (local)	[7:0]	Signal monitor period[15:8]		Bits[15:8] of the 24-bit value that sets the number of output clock cycles over which the signal monitor performs its operation. Only even values are supported.	0x0	R/W
0x0273	Signal Monitor Period 2 (local)	[7:0]	Signal monitor period[23:16]		Bits[23:16] of the 24-bit value that sets the number of output clock cycles over which the signal monitor performs its operation. Only even values are supported.	0x0	R/W
0x0274	Signal monitor status control (local)	[7:5]	Reserved		Reserved.	0x0	R
		4	Result update	1	Update signal monitor status registers, Register 0x0275 to Register 0x0278. Self clearing.	0x0	R/WC
		3	Reserved		Reserved.	0x0	R
		[2:0]	Result selection	001	Peak detector placed on status readback signals.	0x1	R/W
0x0275	Signal Monitor Status 0 (local)	[7:0]	Signal monitor result[7:0]		Signal monitor status result. This 20-bit value contains the status result calculated by the signal monitor block.	0x0	R
0x0276	Signal Monitor Status 1 (local)	[7:0]	Signal monitor result[15:8]		Signal monitor status result.	0x0	R
0x0277	Signal Monitor Status 2 (local)	[7:4]	Reserved		Reserved.	0x0	R
		[3:0]	Signal monitor result[19:16]		Signal monitor status result.	0x0	R
0x0278	Signal monitor status frame counter (local)	[7:0]	Period count result[7:0]		Signal monitor frame counter status bits. The frame counter increments whenever the period counter expires.	0x0	R
0x0279	Signal monitor serial framer control (local)	[7:2]	Reserved		Reserved.	0x0	R
		[1:0]	Signal monitor SPORT over JESD204B enable	00 11	Disabled. Enabled.	0x0	R/W
0x027A	SPORT over JESD204B input selection (local)	[7:6]	Reserved		Reserved.	0x0	R
		1	SPORT over JESD204B input selection	0 1	Signal monitor serial framer input selection. When each individual bit is a 1, the corresponding signal statistics information is sent within the frame. Disabled. Peak detector data inserted in the serial frame.	0x1	R/W
		0	Reserved		Reserved.	0x0	R

DDC Function Registers (See the Digital Downconverter (DDC) Section)

Table 50.

Addr.	Name	Bit(s)	Bit Name	Setting	Description	Reset	Access	
0x0300	DDC SYNC control	7	DDC FTW/POW/MAW/MBW update mode	0	Select DDC FTW/POW/MAW/MBW update mode. Instantaneous/continuous update. FTW/POW/MAW/MBW values are updated immediately.	0x0	R/W	
				1	FTW/POW/MAW/MBW values are updated synchronously when the chip transfer bit (Register 0x000F, Bit 0) is set.			
		6:5	Reserved		Reserved.	0x0	R	
		4	DDC NCO soft reset	0	This bit can be used to synchronize all the NCOs inside the DDC blocks. Normal operation.	0 1	0x0	R/W
				1	DDC held in reset.			
		[3:2]	Reserved		Reserved.	0x0	R	

Addr.	Name	Bit(s)	Bit Name	Setting	Description	Reset	Access
		1	DDC next sync	0 1	Continuous mode. The SYSREF frequency must be an integer multiple of the NCO frequency for this function to operate correctly in continuous mode. Only the next valid edge of the SYSREF± pin is used to synchronize the NCO in the DDC block. Subsequent edges of the SYSREF± pin are ignored. When the next SYSREF signal is found, the DDC synchronization mode bit (Register 0x0300, Bit 0) is cleared.	0x0	R/W
		0	DDC synchronization mode	0 1	The SYSREF± input pin must be enabled to synchronize the DDCs. Synchronization disabled. Synchronization enabled. If Register 0x0300, Bit 1 = 1, only the next valid edge of the SYSREF± pin is used to synchronize the NCO in the DDC block. Subsequent edges of the SYSREF± pin are ignored. When the next SYSREF signal is received, this bit is cleared.	0x0	R/W
0x0310	DDC0 control	7	DDC0 mixer select	0 1	Real mixer (I and Q inputs must be from the same real channel). Complex mixer (I and Q must be from separate, real, and imaginary quadrature ADC receive channels; analog demodulator).	0x0	R/W
		6	DDC0 gain select	0 1	Gain can be used to compensate for the 6 dB loss associated with mixing an input signal down to baseband and filtering out its negative component. 0 dB gain. 6 dB gain (multiply by 2).	0x0	R/W
		[5:4]	DDC0 intermediate frequency (IF) mode	00 01 10 11	Variable IF mode. 0 Hz IF mode. f _s Hz IF mode. Test mode.	0x0	R/W
		3	DDC0 complex to real enable	0 1	Complex (I and Q) outputs contain valid data. Real (I) output only. Complex to real enabled. Uses extra f _s mixing to convert to real.	0x0	R/W
		[2:0]	DDC0 decimation rate select	000 001 010 011 100 101 110 111	Decimation filter selection. HB1 + HB2 filter selection: decimate by 2 (complex to real enabled), or decimate by 4 (complex to real disabled). HB1 + HB2 + HB3 filter selection: decimate by 4 (complex to real enabled), or decimate by 8 (complex to real disabled). HB1 + HB2 + HB3 + HB4 filter selection: decimate by 8 (complex to real enabled), or decimate by 16 (complex to real disabled). HB1 filter selection: decimate by 1 (complex to real enabled), or decimate by 2 (complex to real disabled). HB1 + TB2 filter selection: decimate by 3 (complex to real enabled), or decimate by 6 (complex to real disabled). HB1 + HB2 + TB2 filter selection: decimate by 6 (complex to real enabled), or decimate by 12 (complex to real disabled). HB1 + HB2 + HB3 + TB2 filter selection: decimate by 12 (complex to real enabled), or decimate by 24 (complex to real disabled). Decimation determined by Register 0x0311, Bits[7:4].	0x0	R/W

Addr.	Name	Bit(s)	Bit Name	Setting	Description	Reset	Access
0x0311	DDC0 input select	[7:4]	DDC0 decimation rate select	0000	Only valid when Register 0x0310, Bits[2:0] = 3'b111. TB2 + HB4 + HB3 + HB2 + HB1 filter selection: decimate by 48 (complex to real disabled), or decimate by 24 (complex to real enabled).	0x0	R/W
				0010	FB2 + HB1 filter selection: decimate by 10 (complex to real disabled), or decimate by 5 (complex to real enabled).		
				0011	FB2 + HB2 + HB1 filter selection: decimate by 20 (complex to real disabled), or decimate by 10 (complex to real enabled).		
				0100	FB2 + HB3 + HB2 + HB1 filter selection: decimate by 40 (complex to real disabled), or decimate by 20 (complex to real enabled).		
				0111	TB1 filter selection: decimate by 3 (decimate by 1.5 not supported).		
				1000	FB2 + TB1 filter selection: decimate by 15 (decimate by 7.5 not supported).		
				1001	HB2 + FB2 + TB1 filter selection: decimate by 30 (decimate by 15 not supported).		
				3	Reserved		
		2	DDC0 Q input select	0	Channel A.	0x0	R/W
				1	Channel B.		
1	Reserved	Reserved.	0x0	R			
0	DDC0 I input select	0	Channel A.	0x0	R/W		
1	Channel B.						
0x0314	DDC0 NCO control	[7:4]	DDC0 NCO channel select mode	0000	For edge control, the internal counter wraps after the Register 0x0314, Bits[3:0] value is reached. Use Register 0x0314, Bits[3:0].	0x0	R/W
				0001	GPIO_B0, GPIO_A0.		
				0010	GPIO_B1, GPIO_A1.		
				0011	GPIO_A1, GPIO_A0.		
				0100	GPIO_B1, GPIO_B0.		
				0101	GPIO_B1, GPIO_A1, GPIO_B0, GPIO_A0.		
				0110	GPIO_B1, GPIO_B0, GPIO_A1, GPIO_A0.		
				1000	Increment internal counter on rising edge of the GPIO_A0 pin.		
				1001	Increment internal counter on rising edge of the GPIO_A1 pin.		
				1010	Increment internal counter on rising edge of the GPIO_B0 pin.		
				1011	Increment internal counter on rising edge of the GPIO_B1 pin.		
				[3:0]	DDC0 NCO register map channel select		
		0001	Select NCO Channel 1.				
		0010	Select NCO Channel 2.				
		0011	Select NCO Channel 3.				
		0100	Select NCO Channel 4.				
		0101	Select NCO Channel 5.				
		0110	Select NCO Channel 6.				
		0111	Select NCO Channel 7.				
		1000	Select NCO Channel 8.				
1001	Select NCO Channel 9.						
1010	Select NCO Channel 10.						
1011	Select NCO Channel 11.						
1100	Select NCO Channel 12.						
1101	Select NCO Channel 13.						
1110	Select NCO Channel 14.						
1111	Select NCO Channel 15.						

Addr.	Name	Bit(s)	Bit Name	Setting	Description	Reset	Access
0x0315	DDC0 phase control	[7:4]	Reserved		Reserved.	0x0	R
		[3:0]	DDC0 phase update index	0000 0001 0010 0011	Indexes the NCO channel whose phase and offset is updated. The update method is based on the DDC phase update mode, which can be continuous or require chip transfer. Update NCO Channel 0. Update NCO Channel 1. Update NCO Channel 2. Update NCO Channel 3.	0x0	R/W
0x0316	DDC0 Phase Increment 0	[7:0]	DDC0 phase increment[7:0]		FTW. Twos complement phase increment value for the NCO. Complex mixing frequency = $(\text{DDC phase increment} \times f_s)/2^{48}$.	0x0	R/W
0x0317	DDC0 Phase Increment 1	[7:0]	DDC0 phase increment[15:8]		FTW. Twos complement phase increment value for the NCO. Complex mixing frequency = $(\text{DDC phase increment} \times f_s)/2^{48}$.	0x0	R/W
0x0318	DDC0 Phase Increment 2	[7:0]	DDC0 phase increment[23:16]		FTW. Twos complement phase increment value for the NCO. Complex mixing frequency = $(\text{DDC phase increment} \times f_s)/2^{48}$.	0x0	R/W
0x0319	DDC0 Phase Increment 3	[7:0]	DDC0 phase increment[31:24]		FTW. Twos complement phase increment value for the NCO. Complex mixing frequency = $(\text{DDC phase increment} \times f_s)/2^{48}$.	0x0	R/W
0x031A	DDC0 Phase Increment 4	[7:0]	DDC0 phase increment[39:32]		FTW. Twos complement phase increment value for the NCO. Complex mixing frequency = $(\text{DDC phase increment} \times f_s)/2^{48}$.	0x0	R/W
0x031B	DDC0 Phase Increment 5	[7:0]	DDC0 phase increment[47:40]		FTW. Twos complement phase increment value for the NCO. Complex mixing frequency = $(\text{DDC phase increment} \times f_s)/2^{48}$.	0x0	R/W
0x031D	DDC0 Phase Offset 0	[7:0]	DDC0 phase offset[7:0]		Twos complement POW for the NCO.	0x0	R/W
0x031E	DDC0 Phase Offset 1	[7:0]	DDC0 phase offset[15:8]		Twos complement POW for the NCO.	0x0	R/W
0x031F	DDC0 Phase Offset 2	[7:0]	DDC0 phase offset[23:16]		Twos complement POW for the NCO.	0x0	R/W
0x0320	DDC0 Phase Offset 3	[7:0]	DDC0 phase offset[31:24]		Twos complement POW for the NCO.	0x0	R/W
0x0321	DDC0 Phase Offset 4	[7:0]	DDC0 phase offset[39:32]		Twos complement POW for the NCO.	0x0	R/W
0x0322	DDC0 Phase Offset 5	[7:0]	DDC0 phase offset[47:40]		Twos complement POW for the NCO.	0x0	R/W
0x0327	DDC0 test enable	[7:3]	Reserved		Reserved.	0x0	R
		2	DDC0 Q output test mode enable	0 1	Q samples always use Test Mode B block. The test mode is selected using the channel dependent Register 0x0550, Bits[3:0]. Test mode disabled. Test mode enabled.	0x0	R/W
		1	Reserved		Reserved.	0x0	R
		0	DDC0 I output test mode enable	0 1	I samples always use Test Mode A block. The test mode is selected using the channel dependent Register 0x0550, Bits[3:0]. Test mode disabled. Test mode enabled.	0x0	R/W
0x0330	DDC1 control	7	DDC1 mixer select	0 1	Real mixer (I and Q inputs must be from the same real channel). Complex mixer (I and Q must be from separate, real, and imaginary quadrature ADC receive channels; analog demodulator).	0x0	R/W
				6	DDC1 gain select	0 1	Gain can be used to compensate for the 6 dB loss associated with mixing an input signal down to baseband and filtering out its negative component. 0 dB gain. 6 dB gain (multiply by 2).
		[5:4]	DDC1 IF mode	00 01 10 11	Variable IF mode. 0 Hz IF mode. f_s Hz IF mode. Test mode.	0x0	R/W

Addr.	Name	Bit(s)	Bit Name	Setting	Description	Reset	Access
		3	DDC1 complex to real enable	0 1	Complex (I and Q) outputs contain valid data. Real (I) output only. Complex to real enabled. Uses extra f_s mixing to convert to real.	0x0	R/W
		[2:0]	DDC1 decimation rate select	000 001 010 011 100 101 110 111	Decimation filter selection. HB1 + HB2 filter selection: decimate by 2 (complex to real enabled), or decimate by 4 (complex to real disabled). HB1 + HB2 + HB3 filter selection: decimate by 4 (complex to real enabled), or decimate by 8 (complex to real disabled). HB1 + HB2 + HB3 + HB4 filter selection: decimate by 8 (complex to real enabled), or decimate by 16 (complex to real disabled). HB1 filter selection: decimate by 1 (complex to real enabled), or decimate by 2 (complex to real disabled). HB1 + TB2 filter selection: decimate by 3 (complex to real enabled), or decimate by 6 (complex to real disabled). HB1 + HB2 + TB2 filter selection: decimate by 6 (complex to real enabled), or decimate by 12 (complex to real disabled). HB1 + HB2 + HB3 + TB2 filter selection: decimate by 12 (complex to real enabled), or decimate by 24 (complex to real disabled). Decimation determined by Register 0x0331, Bits[7:4].	0x0	R/W
0x0331	DDC1 input select	[7:4]	DDC1 decimation rate select	0000 0010 0011 0100 0111 1000 1001	Only valid when Register 0x0310, Bits[2:0] = 3'b111. TB2 + HB4 + HB3 + HB2 + HB1 filter selection: decimate by 48 (complex to real disabled), or decimate by 24 (complex to real enabled). FB2 + HB1 filter selection: decimate by 10 (complex to real disabled), or decimate by 5 (complex to real enabled). FB2 + HB2 + HB1 filter selection: decimate by 20 (complex to real disabled), or decimate by 10 (complex to real enabled). FB2 + HB3 + HB2 + HB1 filter selection: decimate by 40 (complex to real disabled), or decimate by 20 (complex to real enabled). TB1 filter selection: decimate by 3 (decimate by 1.5 not supported). FB2 + TB1 filter selection: decimate by 15 (decimate by 7.5 not supported). HB2 + FB2 + TB1 filter selection: decimate by 30 (decimate by 15 not supported).	0x0	R/W
		3	Reserved		Reserved.	0x0	R
		2	DDC1 Q input select	0 1	Channel A. Channel B.	0x1	R/W
		1	Reserved		Reserved.	0x0	R
		0	DDC1 I input select	0 1	Channel A. Channel B.	0x1	R/W
0x0334	DDC1 NCO control	[7:4]	DDC1 NCO channel select mode	0000 0001 0010 0011 0100 0101 0110 1000 1001 1010 1011	For edge control, the internal counter wraps when the Register 0x0334, Bits[3:0] value is reached. Use Register 0x0334, Bits[3:0]. PIO_B0, GPIO_A0. GPIO_B1, GPIO_A1. GPIO_A1, GPIO_A0. GPIO_B1, GPIO_B0. GPIO_B1, GPIO_A1, GPIO_B0, GPIO_A0. GPIO_B1, GPIO_B0, GPIO_A1, GPIO_A0. Increment internal counter on rising edge of the GPIO_A0 pin. Increment internal counter on rising edge of the GPIO_A1 pin. Increment internal counter on rising edge of the GPIO_B0 pin. Increment internal counter on rising edge of the GPIO_B1 pin.	0x0	R/W

Addr.	Name	Bit(s)	Bit Name	Setting	Description	Reset	Access
		[3:0]	DDC1 NCO register map channel select	0000 0001 0010 0011 0100 0101 0110 0111 1000 1001 1010 1011 1100 1101 1110 1111	NCO channel select register map control. Select NCO Channel 0. Select NCO Channel 1. Select NCO Channel 2. Select NCO Channel 3. Select NCO Channel 4. Select NCO Channel 5. Select NCO Channel 6. Select NCO Channel 7. Select NCO Channel 8. Select NCO Channel 9. Select NCO Channel 10. Select NCO Channel 11. Select NCO Channel 12. Select NCO Channel 13. Select NCO Channel 14. Select NCO Channel 15.	0x0	R/W
0x0335	DDC1 phase control	[7:4]	Reserved		Reserved.	0x0	R
		[3:0]	DDC1 phase update index	0000 0001 0010 0011	Indexes the NCO channel whose phase and offset are updated. The update method is based on the DDC phase update mode, which can be continuous or require chip transfer. Update NCO Channel 0. Update NCO Channel 1. Update NCO Channel 2. Update NCO Channel 3.	0x0	R/W
0x0336	DDC1 Phase Increment 0	[7:0]	DDC1 phase increment[7:0]		FTW. Twos complement phase increment value for the NCO. Complex mixing frequency = $(DDC\ phase\ increment \times f_s)/2^{48}$.	0x0	R/W
0x0337	DDC1 Phase Increment 1	[7:0]	DDC1 phase increment[15:8]		FTW. Twos complement phase increment value for the NCO. Complex mixing frequency = $(DDC\ phase\ increment \times f_s)/2^{48}$.	0x0	R/W
0x0338	DDC1 Phase Increment 2	[7:0]	DDC1 phase increment[23:16]		FTW. Twos complement phase increment value for the NCO. Complex mixing frequency = $(DDC\ phase\ increment \times f_s)/2^{48}$.	0x0	R/W
0x0339	DDC1 Phase Increment 3	[7:0]	DDC1 phase increment[31:24]		FTW. Twos complement phase increment value for the NCO. Complex mixing frequency = $(DDC\ phase\ increment \times f_s)/2^{48}$.	0x0	R/W
0x033A	DDC1 Phase Increment 4	[7:0]	DDC1 phase increment[39:32]		FTW. Twos complement phase increment value for the NCO. Complex mixing frequency = $(DDC\ phase\ increment \times f_s)/2^{48}$.	0x0	R/W
0x033B	DDC1 Phase Increment 5	[7:0]	DDC1 phase increment[47:40]		FTW. Twos complement phase increment value for the NCO. Complex mixing frequency = $(DDC\ phase\ increment \times f_s)/2^{48}$.	0x0	R/W
0x033D	DDC1 Phase Offset 0	[7:0]	DDC1 phase offset[7:0]		Twos complement POW for the NCO.	0x0	R/W
0x033E	DDC1 Phase Offset 1	[7:0]	DDC1 phase offset[15:8]		Twos complement POW for the NCO.	0x0	R/W
0x033F	DDC1 Phase Offset 2	[7:0]	DDC1 phase offset[23:16]		Twos complement POW for the NCO.	0x0	R/W
0x0340	DDC1 Phase Offset 3	[7:0]	DDC1 phase offset[31:24]		Twos complement POW for the NCO.	0x0	R/W
0x0341	DDC1 Phase Offset 4	[7:0]	DDC1 phase offset[39:32]		Twos complement POW for the NCO.	0x0	R/W
0x0342	DDC1 Phase Offset 5	[7:0]	DDC1 phase offset[47:40]		Twos complement POW for the NCO.	0x0	R/W
0x0347	DDC1 test enable	[7:3]	Reserved		Reserved.	0x0	R
		2	DDC1 Q output test mode enable	0 1	Q samples always use Test Mode B block. The test mode is selected using the channel dependent Register 0x0550, Bits[3:0]. Test mode disabled. Test mode enabled.	0x0	R/W
		1	Reserved		Reserved.	0x0	R
		0	DDC1 I output test mode enable	0 1	I samples always use Test Mode A block. The test mode is selected using the channel dependent Register 0x0550, Bits[3:0]. Test mode disabled. Test mode enabled.	0x0	R/W

Addr.	Name	Bit(s)	Bit Name	Setting	Description	Reset	Access
0x0350	DDC2 control	7	DDC2 mixer select	0	Real mixer (I and Q inputs must be from the same real channel).	0x0	R/W
				1	Complex mixer (I and Q must be from separate, real and imaginary quadrature ADC receive channels; analog demodulator).		
		6	DDC2 gain select	0	Gain can be used to compensate for the 6 dB loss associated with mixing an input signal down to baseband and filtering out its negative component. 0 dB gain.	0x0	R/W
				1	6 dB gain (multiply by 2).		
		[5:4]	DDC2 IF mode	00	Variable IF mode.	0x0	R/W
01	0 Hz IF mode.						
10	f_s Hz IF mode.						
11	Test mode.						
3	DDC2 complex to real enable	0	Complex (I and Q) outputs contain valid data.	0x0	R/W		
		1	Real (I) output only. Complex to real enabled. Uses extra f_s mixing to convert to real.				
[2:0]	DDC2 decimation rate select	000	Decimation filter selection.	0x0	R/W		
		001	HB1 + HB2 filter selection: decimate by 2 (complex to real enabled), or decimate by 4 (complex to real disabled).				
		010	HB1 + HB2 + HB3 filter selection: decimate by 4 (complex to real enabled), or decimate by 8 (complex to real disabled).				
		011	HB1 + HB2 + HB3 + HB4 filter selection: decimate by 8 (complex to real enabled), or decimate by 16 (complex to real disabled).				
		100	HB1 filter selection: decimate by 1 (complex to real enabled), or decimate by 2 (complex to real disabled).				
		101	HB1 + TB2 filter selection: decimate by 3 (complex to real enabled), or decimate by 6 (complex to real disabled).				
		110	HB1 + HB2 + TB2 filter selection: decimate by 6 (complex to real enabled), or decimate by 12 (complex to real disabled).				
		111	HB1 + HB2 + HB3 + TB2 filter selection: decimate by 12 (complex to real enabled), or decimate by 24 (complex to real disabled). Decimation determined by Register 0x0351, Bits[7:4].				
0x0351	DDC2 input select	[7:4]	DDC2 decimation rate select	000	Only valid when Register 0x0310, Bits[2:0] = 3'b111.	0x0	R/W
				000	TB2 + HB4 + HB3 + HB2 + HB1 filter selection: decimate by 48 (complex to real disabled), or decimate by 24 (complex to real enabled).		
				0010	FB2 + HB1 filter selection: decimate by 10 (complex to real disabled), or decimate by 5 (complex to real enabled).		
				011	FB2 + HB2 + HB1 filter selection: decimate by 20 (complex to real disabled), or decimate by 10 (complex to real enabled).		
		100	FB2 + HB3 + HB2 + HB1 filter selection: decimate by 40 (complex to real disabled), or decimate by 20 (complex to real enabled).				
		3	Reserved	Reserved.	0x0	R	
		2	DDC2 Q input select	0	Channel A.	0x0	R/W
1	Channel B.						
Reserved	Reserved.			0x0	R		
0	DDC2 I input select	0	Channel A.	0x0	R/W		
		1	Channel B.				

Addr.	Name	Bit(s)	Bit Name	Setting	Description	Reset	Access
0x0354	DDC2 NCO control	[7:4]	DDC2 NCO channel select mode	0000 0001 0010 0011 0100 0101 0110 1000 1001 1010 1011	For edge control, the internal counter wraps when the Register 0x0354, Bits[3:0] value is reached. Use Register 0x0354, Bits[3:0]. GPIO_B0, GPIO_A0. GPIO_B1, GPIO_A1. GPIO_A1, GPIO_A0. GPIO_B1, GPIO_B0. GPIO_B1, GPIO_A1, GPIO_B0, GPIO_A0. GPIO_B1, GPIO_B0, GPIO_A1, GPIO_A0. Increment internal counter on rising edge of the GPIO_A0 pin. Increment internal counter on rising edge of the GPIO_A1 pin. Increment internal counter on rising edge of the GPIO_B0 pin. Increment internal counter on rising edge of the GPIO_B1 pin.	0x0	R/W
		[3:0]	DDC2 NCO register map channel select	0000 0001 0010 0011 0100 0101 0110 0111 1000 1001 1010 1011 1100 1101 1110 1111	NCO channel select register map control. Select NCO Channel 0. Select NCO Channel 1. Select NCO Channel 2. Select NCO Channel 3. Select NCO Channel 4. Select NCO Channel 5. Select NCO Channel 6. Select NCO Channel 7. Select NCO Channel 8. Select NCO Channel 9. Select NCO Channel 10. Select NCO Channel 11. Select NCO Channel 12. Select NCO Channel 13. Select NCO Channel 14. Select NCO Channel 15.	0x0	R/W
0x0355	DDC2 phase control	[7:4]	Reserved		Reserved.	0x0	R
		[3:0]	DDC2 phase update index	0000 0001 0010 0011	Indexes the NCO channel whose phase and offset are updated. The update method is based on the DDC phase update mode, which can be continuous or require chip transfer. Update NCO Channel 0. Update NCO Channel 1. Update NCO Channel 2. Update NCO Channel 3.	0x0	R/W
0x0356	DDC2 Phase Increment 0	[7:0]	DDC2 phase increment[7:0]		FTW. Twos complement phase increment value for the NCO. Complex mixing frequency = $(DDC\ phase\ increment \times f_s)/2^{48}$.	0x0	R/W
0x0357	DDC2 Phase Increment 1	[7:0]	DDC2 phase increment[15:8]		FTW. Twos complement phase increment value for the NCO. Complex mixing frequency = $(DDC\ phase\ increment \times f_s)/2^{48}$.	0x0	R/W
0x0358	DDC2 Phase Increment 2	[7:0]	DDC2 phase increment[23:16]		FTW. Twos complement phase increment value for the NCO. Complex mixing frequency = $(DDC\ phase\ increment \times f_s)/2^{48}$.	0x0	R/W
0x0359	DDC2 Phase Increment 3	[7:0]	DDC2 phase increment[31:24]		FTW. Twos complement phase increment value for the NCO. Complex mixing frequency = $(DDC\ phase\ increment \times f_s)/2^{48}$.	0x0	R/W
0x035A	DDC2 Phase Increment 4	[7:0]	DDC2 phase increment[39:32]		FTW. Twos complement phase increment value for the NCO. Complex mixing frequency = $(DDC\ phase\ increment \times f_s)/2^{48}$.	0x0	R/W
0x035B	DDC2 Phase Increment 5	[7:0]	DDC2 phase increment[47:40]		FTW. Twos complement phase increment value for the NCO. Complex mixing frequency = $(DDC\ phase\ increment \times f_s)/2^{48}$.	0x0	R/W
0x035D	DDC2 Phase Offset 0	[7:0]	DDC2 phase offset[7:0]		Twos complement POW for the NCO.	0x0	R/W
0x035E	DDC2 Phase Offset 1	[7:0]	DDC2 phase offset[15:8]		Twos complement POW for the NCO.	0x0	R/W
0x035F	DDC2 Phase Offset 2	[7:0]	DDC2 phase offset[23:16]		Twos complement POW for the NCO.	0x0	R/W
0x0360	DDC2 Phase Offset 3	[7:0]	DDC2 phase offset[31:24]		Twos complement POW for the NCO.	0x0	R/W
0x0361	DDC2 Phase Offset 4	[7:0]	DDC2 phase offset[39:32]		Twos complement POW for the NCO.	0x0	R/W

Addr.	Name	Bit(s)	Bit Name	Setting	Description	Reset	Access
0x0362	DDC2 Phase Offset 5	[7:0]	DDC2 phase offset[47:40]		Twos complement POW for the NCO.	0x0	R/W
0x0367	DDC2 test enable	[7:3]	Reserved		Reserved.	0x0	R
		2	DDC2 Q output test mode enable	0 1	Q samples always use Test Mode B block. The test mode is selected using the channel dependent Register 0x0550, Bits[3:0]. Test mode disabled. Test mode enabled.	0x0	R/W
		1	Reserved		Reserved.	0x0	R
		0	DDC2 I output test mode enable	0 1	I samples always use Test Mode A block. The test mode is selected using the channel dependent Register 0x0550, Bits[3:0]. Test mode disabled. Test mode enabled.	0x0	R/W
0x0370	DDC3 control	7	DDC3 mixer select	0 1	Real mixer (I and Q inputs must be from the same real channel). Complex mixer (I and Q must be from separate, real, and imaginary quadrature ADC receive channels; analog demodulator).	0x0	R/W
		6	DDC3 gain select	0 1	Gain can be used to compensate for the 6 dB loss associated with mixing an input signal down to baseband and filtering out its negative component. 0 dB gain. 6 dB gain (multiply by 2).	0x0	R/W
		[5:4]	DDC3 IF mode	00 01 10 11	Variable If mode. 0 Hz IF mode. f _s Hz IF mode. Test mode.	0x0	R/W
		3	DDC3 complex to real enable	0 1	Complex (I and Q) outputs contain valid data. Real (I) output only. complex to real enabled. Uses extra f _s mixing to convert to real.	0x0	R/W
		[2:0]	DDC3 decimation rate select	000 001 010 011 100 101 110 111	Decimation filter selection. HB1 + HB2 filter selection: decimate by 2 (complex to real enabled), or decimate by 4 (complex to real disabled). HB1 + HB2 + HB3 filter selection: decimate by 4 (complex to real enabled), or decimate by 8 (complex to real disabled). HB1 + HB2 + HB3 + HB4 filter selection: decimate by 8 (complex to real enabled), or decimate by 16 (complex to real disabled). HB1 filter selection: decimate by 1 (complex to real enabled), or decimate by 2 (complex to real disabled). HB1 + TB2 filter selection: decimate by 3 (complex to real enabled), or decimate by 6 (complex to real disabled). HB1 + HB2 + TB2 filter selection: decimate by 6 (complex to real enabled), or decimate by 12 (complex to real disabled). HB1 + HB2 + HB3 + TB2 filter selection: decimate by 12 (complex to real enabled), or decimate by 24 (complex to real disabled). Decimation determined by Register 0x0371, Bits[7:4].	0x0	R/W
		0x0371	DDC3 input select	[7:4]	DDC3 decimation rate select	000 010 011 100	Only valid when Register 0x0310, Bits[2:0] = 3'b111. TB2 + HB4 + HB3 + HB2 + HB1 filter selection: decimate by 48 (complex to real disabled), or decimate by 24 (complex to real enabled). FB2 + HB1 filter selection: decimate by 10 (complex to real disabled), or decimate by 5 (complex to real enabled). FB2 + HB2 + HB1 filter selection: decimate by 20 (complex to real disabled), or decimate by 10 (complex to real enabled). FB2 + HB3 + HB2 + HB1 filter selection: decimate by 40 (complex to real disabled), or decimate by 20 (complex to real enabled).
		3	Reserved		Reserved.	0x0	R

Addr.	Name	Bit(s)	Bit Name	Setting	Description	Reset	Access
		2	DDC3 Q input select	0 1	Channel A. Channel B.	0x1	R/W
		1	Reserved		Reserved.	0x0	R
		0	DDC3 I input select	0 1	Channel A. Channel B.	0x1	R/W
0x0374	DDC3 NCO control	[7:4]	DDC3 NCO channel select mode	0000 0001 0010 0011 0100 0101 0110 1000 1001 1010 1011	For edge control, the internal counter wraps when the Register 0x0374, Bits[3:0] value is reached. Use Register 0x0374, Bits[3:0]. GPIO_B0, GPIO_A0. GPIO_B1, GPIO_A1. GPIO_A1, GPIO_A0. GPIO_B1, GPIO_B0. GPIO_B1, GPIO_A1, GPIO_B0, GPIO_A0. GPIO_B1, GPIO_B0, GPIO_A1, GPIO_A0. Increment internal counter when rising edge of GPIO_A0 pin. Increment internal counter when rising edge of GPIO_A1 pin. Increment internal counter when rising edge of GPIO_B0 pin. Increment internal counter when rising edge of GPIO_B1 pin.	0x0	R/W
		[3:0]	DDC3 NCO register map channel select	0000 0001 0010 0011 0100 0101 0110 0111 1000 1001 1010 1011 1100 1101 1110 1111	NCO channel select register map control. Select NCO Channel 0. Select NCO Channel 1. Select NCO Channel 2. Select NCO Channel 3. Select NCO Channel 4. Select NCO Channel 5. Select NCO Channel 6. Select NCO Channel 7. Select NCO Channel 8. Select NCO Channel 9. Select NCO Channel 10. Select NCO Channel 11. Select NCO Channel 12. Select NCO Channel 13. Select NCO Channel 14. Select NCO Channel 15.	0x0	R/W
0x0375	DDC3 phase control	[7:4]	Reserved		Reserved.	0x0	R
		[3:0]	DDC3 phase update index	0000 0001 0010 0011	Indexes the NCO channel whose phase and offset gets updated. The update method is based on the DDC phase update mode, which can be continuous or require chip transfer. Update NCO Channel 0. Update NCO Channel 1. Update NCO Channel 2. Update NCO Channel 3.	0x0	R/W
0x0376	DDC3 Phase Increment 0	[7:0]	DDC3 phase increment[7:0]		FTW. Twos complement phase increment value for the NCO. Complex mixing frequency = $(DDC \text{ phase increment} \times f_s)/2^{48}$.	0x0	R/W
0x0377	DDC3 Phase Increment 1	[7:0]	DDC3 phase increment[15:8]		FTW. Twos complement phase increment value for the NCO. Complex mixing frequency = $(DDC \text{ phase increment} \times f_s)/2^{48}$.	0x0	R/W
0x0378	DDC3 Phase Increment 2	[7:0]	DDC3 phase increment[23:16]		FTW. Twos complement phase increment value for the NCO. Complex mixing frequency = $(DDC \text{ phase increment} \times f_s)/2^{48}$.	0x0	R/W
0x0379	DDC3 Phase Increment 3	[7:0]	DDC3 phase increment[31:24]		FTW. Twos complement phase increment value for the NCO. Complex mixing frequency = $(DDC \text{ phase increment} \times f_s)/2^{48}$.	0x0	R/W
0x037A	DDC3 Phase Increment 4	[7:0]	DDC3 phase increment[39:32]		FTW. Twos complement phase increment value for the NCO. Complex mixing frequency = $(DDC \text{ phase increment} \times f_s)/2^{48}$.	0x0	R/W
0x037B	DDC3 Phase Increment 5	[7:0]	DDC3 phase increment[47:40]		FTW. Twos complement phase increment value for the NCO. Complex mixing frequency = $(DDC \text{ phase increment} \times f_s)/2^{48}$.	0x0	R/W
0x037D	DDC3 Phase Offset 0	[7:0]	DDC3 phase offset[7:0]		Twos complement POW for the NCO.	0x0	R/W

Addr.	Name	Bit(s)	Bit Name	Setting	Description	Reset	Access
0x037E	DDC3 Phase Offset 1	[7:0]	DDC3 phase offset[15:8]		Twos complement POW for the NCO.	0x0	R/W
0x037F	DDC3 Phase Offset 2	[7:0]	DDC3 phase offset[23:16]		Twos complement POW for the NCO.	0x0	R/W
0x0380	DDC3 Phase Offset 3	[7:0]	DDC3 phase offset[31:24]		Twos complement POW for the NCO.	0x0	R/W
0x0381	DDC3 Phase Offset 4	[7:0]	DDC3 phase offset[39:32]		Twos complement POW for the NCO.	0x0	R/W
0x0382	DDC3 Phase Offset 5	[7:0]	DDC3 phase offset[47:40]		Twos complement POW for the NCO.	0x0	R/W
0x0387	DDC3 test enable	[7:3]	Reserved		Reserved.	0x0	R
		2	DDC3 Q output test mode enable	0 1	Q samples always use Test Mode B block. The test mode is selected using the channel dependent Register 0x0550, Bits[3:0]. Test mode disabled. Test mode enabled.	0x0	R/W
		1	Reserved		Reserved.	0x0	R
		0	DDC3 I output test mode enable	0 1	I samples always use Test Mode A block. The test mode is selected using the channel dependent Register 0x0550, Bits[3:0]. Test mode disabled. Test mode enabled.	0x0	R/W
0x0390	DDC0 Phase Increment Frac A0	[7:0]	DDC0 Phase Increment Frac A[7:0]		Numerator correction term for Phase Accumulator MAW	0x0	R/W
0x0391	DDC0 Phase Increment Frac A1	[7:0]	DDC0 Phase Increment Frac A[15:8]		Numerator correction term for MAW.	0x0	R/W
0x0392	DDC0 Phase Increment Frac A2	[7:0]	DDC0 Phase Increment Frac A[23:16]		Numerator correction term for MAW.	0x0	R/W
0x0393	DDC0 Phase Increment Frac A3	[7:0]	DDC0 Phase Increment Frac A[31:24]		Numerator correction term for MAW.	0x0	R/W
0x0394	DDC0 Phase Increment Frac A4	[7:0]	DDC0 Phase Increment Frac A[39:32]		Numerator correction term for MAW.	0x0	R/W
0x0395	DDC0 Phase Increment Frac A5	[7:0]	DDC0 Phase Increment Frac A[47:40]		Numerator correction term for MAW.	0x0	R/W
0x0398	DDC0 Phase Increment Frac B0	[7:0]	DDC0 Phase Increment Frac B[7:0]		Denominator correction term for Phase Accumulator MBW	0x0	R/W
0x0399	DDC0 Phase Increment Frac B1	[7:0]	DDC0 Phase Increment Frac B[15:8]		Denominator correction term for MBW.	0x0	R/W
0x039A	DDC0 Phase Increment Frac B2	[7:0]	DDC0 Phase Increment Frac B[23:16]		Denominator correction term for MBW.	0x0	R/W
0x039B	DDC0 Phase Increment Frac B3	[7:0]	DDC0 Phase Increment Frac B[31:24]		Denominator correction term for MBW.	0x0	R/W
0x039C	DDC0 Phase Increment Frac B4	[7:0]	DDC0 Phase Increment Frac B[39:32]		Denominator correction term for MBW.	0x0	R/W
0x039D	DDC0 Phase Increment Frac B5	[7:0]	DDC0 Phase Increment Frac B[47:40]		Denominator correction term for MBW.	0x0	R/W
0x03A0	DDC1 Phase Increment Frac A0	[7:0]	DDC1 Phase Increment Frac A[7:0]		Numerator correction term for MAW.	0x0	R/W
0x03A1	DDC1 Phase Increment Frac A1	[7:0]	DDC1 Phase Increment Frac A[15:8]		Numerator correction term for MAW.	0x0	R/W

Addr.	Name	Bit(s)	Bit Name	Setting	Description	Reset	Access
0x03A2	DDC1 Phase Increment Frac A2	[7:0]	DDC1 Phase Increment Frac A[23:16]		Numerator correction term for MAW.	0x0	R/W
0x03A3	DDC1 Phase Increment Frac A3	[7:0]	DDC1 Phase Increment Frac A[31:24]		Numerator correction term for MAW.	0x0	R/W
0x03A4	DDC1 Phase Increment Frac A4	[7:0]	DDC1 Phase Increment Frac A[39:32]		Numerator correction term for MAW.	0x0	R/W
0x03A5	DDC1 Phase Increment Frac A5	[7:0]	DDC1 Phase Increment Frac A[47:40]		Numerator correction term for MAW.	0x0	R/W
0x03A8	DDC1 Phase Increment Frac B0	[7:0]	DDC1 Phase Increment Frac B[7:0]		Denominator correction term for MBW.	0x0	R/W
0x03A9	DDC1 Phase Increment Frac B1	[7:0]	DDC1 Phase Increment Frac B[15:8]		Denominator correction term for MBW.	0x0	R/W
0x03AA	DDC1 Phase Increment Frac B2	[7:0]	DDC1 Phase Increment Frac B[23:16]		Denominator correction term for MBW.	0x0	R/W
0x03AB	DDC1 Phase Increment Frac B3	[7:0]	DDC1 Phase Increment Frac B[31:24]		Denominator correction term for MBW.	0x0	R/W
0x03AC	DDC1 Phase Increment Frac B4	[7:0]	DDC1 Phase Increment Frac B[39:32]		Denominator correction term for MBW.	0x0	R/W
0x03AD	DDC1 Phase Increment Frac B5	[7:0]	DDC1 Phase Increment Frac B[47:40]		Denominator correction term for MBW.	0x0	R/W
0x03B0	DDC2 Phase Increment Frac A0	[7:0]	DDC2 Phase Increment Frac A[7:0]		Numerator correction term for MAW.	0x0	R/W
0x03B1	DDC2 Phase Increment Frac A1	[7:0]	DDC2 Phase Increment Frac A[15:8]		Numerator correction term for MAW.	0x0	R/W
0x03B2	DDC2 Phase Increment Frac A2	[7:0]	DDC2 Phase Increment Frac A[23:16]		Numerator correction term for MAW.	0x0	R/W
0x03B3	DDC2 Phase Increment Frac A3	[7:0]	DDC2 Phase Increment Frac A[31:24]		Numerator correction term for MAW.	0x0	R/W
0x03B4	DDC2 Phase Increment Frac A4	[7:0]	DDC2 Phase Increment Frac A[39:32]		Numerator correction term for MAW.	0x0	R/W
0x03B5	DDC2 Phase Increment Frac A5	[7:0]	DDC2 Phase Increment Frac A[47:40]		Numerator correction term for MAW.	0x0	R/W
0x03B8	DDC2 Phase Increment Frac B0	[7:0]	DDC2 Phase Increment Frac B[7:0]		Denominator correction term for MBW.	0x0	R/W
0x03B9	DDC2 Phase Increment Frac B1	[7:0]	DDC2 Phase Increment Frac B[15:8]		Denominator correction term for MBW.	0x0	R/W
0x03BA	DDC2 Phase Increment Frac B2	[7:0]	DDC2 Phase Increment Frac B[23:16]		Denominator correction term for MBW.	0x0	R/W
0x03BB	DDC2 Phase Increment Frac B3	[7:0]	DDC2 Phase Increment Frac B[31:24]		Denominator correction term for MBW.	0x0	R/W
0x03BC	DDC2 Phase Increment Frac B4	[7:0]	DDC2 Phase Increment Frac B[39:32]		Denominator correction term for MBW.	0x0	R/W
0x03BD	DDC2 Phase Increment Frac B5	[7:0]	DDC2 Phase Increment Frac B[47:40]		Denominator correction term for MBW.	0x0	R/W

Addr.	Name	Bit(s)	Bit Name	Setting	Description	Reset	Access
0x03C0	DDC3 Phase Increment Frac A0	[7:0]	DDC3 Phase Increment Frac A[7:0]		Numerator correction term for MAW.	0x0	R/W
0x03C1	DDC3 Phase Increment Frac A1	[7:0]	DDC3 Phase Increment Frac A[15:8]		Numerator correction term for MAW.	0x0	R/W
0x03C2	DDC3 Phase Increment Frac A2	[7:0]	DDC3 Phase Increment Frac A[23:16]		Numerator correction term for MAW.	0x0	R/W
0x03C3	DDC3 Phase Increment Frac A3	[7:0]	DDC3 Phase Increment Frac A[31:24]		Numerator correction term for MAW.	0x0	R/W
0x03C4	DDC3 Phase Increment Frac A4	[7:0]	DDC3 Phase Increment Frac A[39:32]		Numerator correction term for MAW.	0x0	R/W
0x03C5	DDC3 Phase Increment Frac A5	[7:0]	DDC3 Phase Increment Frac A[47:40]		Numerator correction term for MAW.	0x0	R/W
0x03C8	DDC3 Phase Increment Frac B0	[7:0]	DDC3 Phase Increment Frac B[7:0]		Denominator correction term for MBW.	0x0	R/W
0x03C9	DDC3 Phase Increment Frac B1	[7:0]	DDC3 Phase Increment Frac B[15:8]		Denominator correction term for MBW.	0x0	R/W
0x03CA	DDC3 Phase Increment Frac B2	[7:0]	DDC3 Phase Increment Frac B[23:16]		Denominator correction term for MBW.	0x0	R/W
0x03CB	DDC3 Phase Increment Frac B3	[7:0]	DDC3 Phase Increment Frac B[31:24]		Denominator correction term for MBW.	0x0	R/W
0x03CC	DDC3 Phase Increment Frac B4	[7:0]	DDC3 Phase Increment Frac B[39:32]		Denominator correction term for MBW.	0x0	R/W
0x03CD	DDC3 Phase Increment Frac B5	[7:0]	DDC3 Phase Increment Frac B[47:40]		Denominator correction term for MBW.	0x0	R/W

Digital Outputs and Test Modes

Table 51.

Addr.	Name	Bit(s)	Bit Name	Setting	Description	Reset	Access
0x0550	ADC test mode control (local)	7	User pattern selection	0 1	Test mode user pattern selection. This bit is only used when Register 0x0550, Bits[3:0] = 4'b1000 (user input mode). Otherwise, it is ignored. User Pattern 1 is found in the User Patten 1 MSB (0x0552) and User Pattern 1 LSB (0x0551) registers. User Pattern 2 is found in the User Pattern 2 MSB (0x0554) and User Pattern 2 LSB (0x0553) registers, and so on. 0 Continuous/repeat pattern. Place each user pattern (1, 2, 3, and 4) on the output for 1 clock cycle and then repeat. (Output the following user patterns: 1, 2, 3, 4, 1, 2, 3, 4, 1, 2, 3, 4, and so on.) 1 Single pattern. Place each user pattern (1, 2, 3, and 4) on the output for 1 clock cycle and then output all zeros. (Output the following user patterns: 1, 2, 3, 4, and then output all zeros.)	0x0	R/W
		6	Reserved		Reserved.	0x0	R
		5	Reset PN long generator	0 1	Test mode long pseudorandom number test generator reset. 0 Long PN enabled. 1 Long PN held in reset.	0x0	R/W
		4	Reset PN short generator	0 1	Test mode short pseudorandom number test generator reset. 0 Short PN enabled. 1 Short PN held in reset.	0x0	R/W

Addr.	Name	Bit(s)	Bit Name	Setting	Description	Reset	Access
		[3:0]	Test mode selection	0000 0001 0010 0011 0100 0101 0110 0111 1000 1111	Test mode generation selection. Off (normal operation). Midscale short. Positive full scale. Negative full scale. Alternating checker board. PN sequence (long). PN sequence (short). 1/0 word toggle. User pattern test mode (used with Register 0x0550, Bit 7 and the User Pattern 1, User Pattern 2, User Pattern 3, and User Pattern 4 registers). Ramp output.	0x0	R/W
0x0551	User Pattern 1 LSB	[7:0]	User Pattern 1[7:0]		User Test Pattern 1 least significant byte.	0x0	R/W
0x0552	User Pattern 1 MSB	[7:0]	User Pattern 1[15:8]		User Test Pattern 1 least significant byte.	0x0	R/W
0x0553	User Pattern 2 LSB	[7:0]	User Pattern 2[7:0]		User Test Pattern 2 least significant byte.	0x0	R/W
0x0554	User Pattern 2 MSB	[7:0]	User Pattern 2[15:8]		User Test Pattern 2 least significant byte.	0x0	R/W
0x0555	User Pattern 3 LSB	[7:0]	User Pattern 3[7:0]		User Test Pattern 3 least significant byte.	0x0	R/W
0x0556	User Pattern 3 MSB	[7:0]	User Pattern 3[15:8]		User Test Pattern 3 least significant byte.	0x0	R/W
0x0557	User Pattern 4 LSB	[7:0]	User Pattern 4[7:0]		User Test Pattern 4 least significant byte.	0x0	R/W
0x0558	User Pattern 4 MSB	[7:0]	User Pattern 4[15:8]		User Test Pattern 4 least significant byte.	0x0	R/W
0x0559	Output Mode Control 1	[7:4]	Converter control Bit 1 selection	0000 0001 0010 0011 0101	Tie low (1'b0). Overrange bit. Signal monitor bit. Fast detect (FD) bit. SYSREF.	0x0	R/W
		[3:0]	Converter control Bit 0 selection	0000 0001 0010 0011 0101	Tie low (1'b0). Overrange bit. Signal monitor bit. Fast detect (FD) bit. SYSREF.	0x0	R/W
0x055A	Output Mode Control 2	[7:4]	Reserved		Reserved.	0x0	R
		[3:0]	Converter control Bit 2 selection	0000 0001 0010 0011 0101	Tie low (1'b0). Overrange bit. Signal monitor bit. Fast detect (FD) bit. SYSREF.	0x1	R/W
0x0561	Out sample mode	[7:3]	Reserved		Reserved.	0x0	R/W
		2	Sample invert	0 1	ADC sample data is not inverted. ADC sample data is inverted.	0x0	R/W
		[1:0]	Data format select	00 01	Offset binary. Twos complement (default).	0x1	R/W
0x0562	Out overrange clear	[7:0]	Data format overrange clear	0 1	Overrange clear bits (one bit for each virtual converter). Writing a 1 to the overrange clear bit clears the corresponding overrange sticky bit. Overrange bit enabled. Overrange bit cleared.	0x0	R/W

Addr.	Name	Bit(s)	Bit Name	Setting	Description	Reset	Access
0x0563	Out overrange status	[7:0]	Data format overrange	0 1	Overrange sticky bit status (one bit for each virtual converter). Writing a 1 to the overrange clear bit clears the corresponding overrange sticky bit. No overrange has occurred. Overrange has occurred.	0x0	R
0x0564	Out channel select	[7:1]	Reserved		Reserved.	0x0	R
		0	Converter channel swap control	0 1	Normal channel ordering. Channel swap enabled.	0x0	R/W
0x056E	PLL control	[7:4]	JESD204B lane rate control	0000 0001 0011 0101	Lane rate = 6.75 Gbps to 13.5 Gbps. Lane rate = 3.375 Gbps to 6.75 Gbps. Lane rate = 13.5 Gbps to 16 Gbps. Lane rate = 1.6875 Gbps to 3.375 Gbps.	0x3	R/W
		[3:0]	Reserved		Reserved.	0x0	R
0x056F	PLL status	7	PLL lock status	0 1	Not locked. Locked.	0x0	R
		[6:4]	Reserved		Reserved.	0x0	R
		3	PLL loss of lock	1	Loss of lock sticky bit. Indicate a loss of lock has occurred at some time. Cleared by setting Register 0x0571, Bit 0.		
		[2:0]	Reserved		Reserved.		
0x0570	$f_s \times 4$ configuration	[7:0]		0xFE 0xFF	See the $f_s \times 4$ Mode section. $f_s \times 4$ mode enabled. L = 8; M = 2; F = 2; S = 4; N' = 16; N = 16; CS = 0; CF = 0; HD = 0. $f_s \times 4$ mode disabled. L, M, and F set by Register 0x058B, Bits[4:0]; Register 0x58E, Bits[7:0]; and Register 0x058C, Bits[7:0], respectively.	0xFF	R/W
0x0571	JESD204B Link Control 1	7	Standby mode	0 1	Standby mode forces zeros for all converter samples. Standby mode forces code group synchronization (/K28.5/ characters).	0x0	R/W
				6	Tail bit(t) PN	0 1	Disable. Enable.
		5	Long transport layer test	0 1	JESD204B test samples disabled. JESD204B test samples enabled; long transport layer test sample sequence (as specified in JESD204B Section 5.1.6.3) sent on all link lanes.	0x0	R/W
		4	Lane synchronization	0 1	Disable FACI uses /K28.7/. Enable FACI uses /K28.3/ and /K28.7/.	0x1	R/W
		[3:2]	ILAS sequence mode	00 01 11	Initial lane alignment sequence disabled (JESD204B Section 5.3.3.5). Initial lane alignment sequence enabled (JESD204B Section 5.3.3.5). Initial lane alignment sequence always in test mode. JESD204B data link layer test mode where repeated lane alignment sequence (as specified in JESD204B Section 5.3.3.8.2) sent on all lanes.	0x1	R/W
		1	FACI	0 1	Frame alignment character insertion enabled (JESD204B Section 5.3.3.4). Frame alignment character insertion disabled. For debug only (JESD204B Section 5.3.3.4).	0x0	R/W

Addr.	Name	Bit(s)	Bit Name	Setting	Description	Reset	Access
		0	Link control	0 1	JESD204B serial transmit link enabled. Transmission of the /K28.5/ characters for code group synchronization is controlled by the SYNC~ pin. JESD204B serial transmit link powered down (held in reset and clock gated).	0x0	R/W
0x0572	JESD204B Link Control 2	[7:6]	SYNCINB± pin control	00 10 11	Normal mode. Ignore SYNCINB± (force CGS). Ignore SYNCINB± (force ILAS/user data).	0x0	R/W
		5	SYNCINB± pin invert	0 1	SYNCINB± pin not inverted. SYNCINB± pin inverted.	0x0	R/W
		4	SYNCINB± pin type	0 1	LVDS differential pair SYNC~ input. CMOS single-ended SYNC~ input. SYNCINB+ used.	0x0	R/W
		3	Reserved		Reserved.	0x0	R
		2	8-bit/10-bit bypass	0 1	8-bit/10-bit enabled. 8-bit/10-bit bypassed (most significant 2 bits are 0).	0x0	R/W
		1	8-bit/10-bit invert	0 1	Normal. Invert a, b, c, d, e, f, g, h, i, j, symbols.	0x0	R/W
		0	Reserved		Reserved.	0x0	R/W
0x0573	JESD204B Link Control 3	[7:6]	Checksum mode	00 01 10 11	Checksum is the sum of all 8-bit registers in the link configuration table. Checksum is the sum of all individual link configuration fields (LSB aligned). Checksum is disabled (set to zero). For test purposes only. Unused.	0x0	R/W
		[5:4]	Test injection point	0 1 10	N ¹ sample input. 10-bit data at 8-bit/10-bit output (for PHY testing). 8-bit data at scrambler input.	0x0	R/W
		[3:0]	JESD204B test mode patterns	0000 0001 0010 0011 0100 0101 0110 0111 1000 1110 1111	Normal operation (test mode disabled). Alternating checkerboard. 1/0 word toggle. 31-bit PN sequence: $x^{31} + x^{28} + 1$. 23-bit PN sequence: $x^{23} + x^{18} + 1$. 15-bit PN sequence: $x^{15} + x^{14} + 1$. 9-bit PN sequence: $x^9 + x^5 + 1$. 7-bit PN sequence: $x^7 + x^6 + 1$. Ramp output. Continuous/repeat user test. Single user test.	0x0	R/W

Addr.	Name	Bit(s)	Bit Name	Setting	Description	Reset	Access
0x0574	JESD204B Link Control 4	[7:4]	ILAS delay	0000	Transmit ILAS on first LMFC after SYNCINB± is deasserted.	0x0	R/W
				0001	Transmit ILAS on second LMFC after SYNCINB± is deasserted.		
				0010	Transmit ILAS on third LMFC after SYNCINB± is deasserted.		
				0011	Transmit ILAS on fourth LMFC after SYNCINB± is deasserted.		
				0100	Transmit ILAS on fifth LMFC after SYNCINB± is deasserted.		
				0101	Transmit ILAS on sixth LMFC after SYNCINB± is deasserted.		
				0110	Transmit ILAS on seventh LMFC after SYNCINB± is deasserted.		
				0111	Transmit ILAS on eighth LMFC after SYNCINB± is deasserted.		
				1000	Transmit ILAS on ninth LMFC after SYNCINB± is deasserted.		
				1001	Transmit ILAS on tenth LMFC after SYNCINB± is deasserted.		
				1010	Transmit ILAS on eleventh LMFC after SYNCINB± is deasserted.		
				1011	Transmit ILAS on twelfth LMFC after SYNCINB± is deasserted.		
				1100	Transmit ILAS on thirteenth LMFC after SYNCINB± is deasserted.		
				1101	Transmit ILAS on fourteenth LMFC after SYNCINB± is deasserted.		
		1110	Transmit ILAS on fifteenth LMFC after SYNCINB± is deasserted.				
		3	Reserved		Reserved.	0x0	R
		[2:0]	Link layer test mode	000	Normal operation (link layer test mode disabled).	0x0	R/W
				001	Continuous sequence of /D21.5/ characters.		
				010	Reserved.		
				011	Reserved.		
				100	Modified RPAT test sequence.		
				101	JSPAT test sequence.		
				110	JTSPAT test sequence.		
				111	Reserved.		
0x0578	JESD204B LMFC offset	[7:5]	Reserved		Reserved.	0x0	R
		[4:0]	LMFC phase offset value		LMFC phase offset value (in frame clocks). Refer to the Deterministic Latency section.	0x0	R/W
0x0580	JESD204B DID configuration	[7:0]	JESD204B Tx DID value		JESD204B serial device identification (DID) number.	0x0	R/W
0x0581	JESD204B BID configuration	[7:4]	Reserved		Reserved.	0x0	R
		[3:0]	JESD204B Tx BID value		JESD204B serial bank identification (BID) number (extension to DID).	0x0	R/W
0x0583	JESD204B LID0 configuration	[7:5]	Reserved		Reserved.	0x0	R
		[4:0]	Lane 0 LID value		JESD204B serial lane identification (LID) number for Lane 0.	0x0	R/W
0x0584	JESD204B LID1 configuration	[7:5]	Reserved		Reserved.	0x0	R
		[4:0]	Lane 1 LID value		JESD204B serial LID number for Lane 1.	0x1	R/W
0x0585	JESD204B LID2 configuration	[7:5]	Reserved		Reserved.	0x0	R
		[4:0]	Lane 2 LID value		JESD204B serial LID number for Lane 2.	0x2	R/W
0x0586	JESD204B LID3 configuration	[7:5]	Reserved		Reserved.	0x0	R
		[4:0]	Lane 3 LID value		JESD204B serial LID number for Lane 3.	0x3	R/W
0x0587	JESD204B LID4 configuration	[7:5]	Reserved		Reserved.	0x0	R
		[4:0]	Lane 4 LID value		JESD204B serial LID number for Lane 4.	0x4	R/W
0x0588	JESD204B LID5 configuration	[7:5]	Reserved		Reserved.	0x0	R
		[4:0]	Lane 5 LID value		JESD204B serial LID number for Lane 5.	0x5	R/W
0x0589	JESD204B LID6 configuration	[7:5]	Reserved		Reserved.	0x0	R
		[4:0]	Lane 6 LID value		JESD204B serial LID number for Lane 6.	0x6	R/W
0x058A	JESD204B LID7 configuration	[7:5]	Reserved		Reserved.	0x0	R
		[4:0]	Lane 7 LID value		JESD204B serial LID number for Lane 7.	0x7	R/W

Addr.	Name	Bit(s)	Bit Name	Setting	Description	Reset	Access		
0x058B	JESD204B scrambling and number of lanes (L) configuration	7	JESD204B scrambling (SCR)	0 1	JESD204B scrambler disabled (SCR = 0). JESD204B scrambler enabled (SCR = 1).	0x1	R/W		
		[6:5]	Reserved		Reserved.	0x0	R		
		[4:0]	JESD204B lanes (L)	0x0 0x1 0x3 0x7	One lane per link (L = 1). Two lanes per link (L = 2). Four lanes per link (L = 4). Eight lanes per link (L = 8).	0x7	R/W		
0x058C	JESD204B link number of octets per frames (F)	[7:0]	JESD204B F configuration	0000 0001 0010 0011 0101 0111 1111	JESD204B number of octets per frame (F = 0x058C[7:0] + 1) F = 1. F = 2. F = 3. F = 4. F = 6. F = 8. F = 16.	0x0	R/W		
				0x058D	JESD204B link number of frames per multiframe (K)	[7:5]	Reserved		Reserved.
		[4:0]	JESD204B K configuration		JESD204B number of frames per multiframe (K = 0x058C[4:0] + 1). Only values where F × K is divisible by 4 can be used.	0x1F	R/W		
0x058E	JESD204B link number of converters (M)	[7:0]	JESD204B M configuration	000 001 011 111	JESD204B number of converters per link per device (M = JESD204B M configuration). Link connected to one virtual converter (M = 1). Link connected to two virtual converters (M = 2). Link connected to four virtual converters (M = 4). Link connected to eight virtual converters (M = 8).	0x1	R/W		
0x058F	JESD204B number of control bits (CS) and ADC resolution (N)	[7:6]	Number of control bits (CS) per sample	000 001 010 011	No control bits (CS = 0). 1 control bit (CS = 1), Control Bit 2 only. 2 control bits (CS = 2), Control Bit 2 and Control Bit 1 only. 3 control bits (CS = 3), all control bits (Control Bit 2, Control Bit 1, and Control Bit 0).	0x0	R/W		
				5	Reserved		Reserved.	0x0	R
				[4:0]	ADC converter resolution (N)	00110 00111 01000 01001 01010 01011 01100 01101 01110 01111	N = 7-bit resolution. N = 8-bit resolution. N = 9-bit resolution. N = 10-bit resolution. N = 11-bit resolution. N = 12-bit resolution. N = 13-bit resolution. N = 14-bit resolution. N = 15-bit resolution. N = 16-bit resolution.	0xF	R/W

Addr.	Name	Bit(s)	Bit Name	Setting	Description	Reset	Access
0x0590	JESD204B SCV NP configuration	[7:5]	Subclass support	000 001	Subclass 0. Subclass 1.	0x1	R/W
		[4:0]	ADC number of bits per sample (N')	0 0111 0 1011 0 1111	N' = 8. N' = 12 N' = 16.	0xF	R/W
0x0591	JESD204B JV S configuration	[7:5]	Reserved		Reserved.	0x1	R
		[4:0]	Samples per converter frame cycle (S)		Samples per converter frame cycle (S = 0x0591[4:0] + 1).	0x0	R
0x0592	JESD204B HD CF configuration	7	HD value	0 1	High density format disabled. High density format enabled.	0x0	R
		[6:5]	Reserved		Reserved.	0x0	R
		[4:0]	Control words per frame clock cycle per link (CF)		Number of control words per frame clock cycle per link (CF = Register 0x0592, Bits[4:0]).	0x0	R
0x05A0	JESD204B Checksum 0 configuration	[7:0]	Checksum 0 checksum value for SERDOUT0±		Serial checksum value for Lane 0. Automatically calculated for each lane. Sum(all link configuration parameters for Lane 0) mod 256.	0xC3	R
0x05A1	JESD204B Checksum 1 configuration	[7:0]	Checksum 1 checksum value for SERDOUT1±		Serial checksum value for Lane 1. Automatically calculated for each lane. Sum(all link configuration parameters for Lane 1) mod 256.	0xC4	R
0x05A2	JESD204B Checksum 2 configuration	[7:0]	Checksum 2 checksum value for SERDOUT2±		Serial checksum value for Lane 2. Automatically calculated for each lane. Sum(all link configuration parameters for each lane) mod 256.	0xC5	R
0x05A3	JESD204B Checksum 3 configuration	[7:0]	Checksum 3 checksum value for SERDOUT3±		Serial checksum value for Lane 3. Automatically calculated for each lane. Sum(all link configuration parameters for Lane 3) mod 256.	0xC6	R
0x05B0	JESD204B lane power- down	7	JESD204B Lane 7 power-down	0 1	Physical Lane 7 force power-down. SERDOUT7± normal operation. SERDOUT7± power-down.	0x0	R/W
		6	JESD204B Lane 6 power-down	0 1	Physical Lane 6 force power-down. SERDOUT6± normal operation. SERDOUT6± power-down.	0x0	R/W
		5	JESD204B Lane 5 power-down	0 1	Physical Lane 5 force power-down. SERDOUT5± normal operation. SERDOUT5± power-down.	0x0	R/W
		4	JESD204B Lane 4 power-down	0 1	Physical Lane 4 force power-down. SERDOUT4± normal operation. SERDOUT4± power-down.	0x0	R/W
		3	JESD204B Lane 3 power-down	0 1	Physical Lane 3 force power-down. SERDOUT3± normal operation. SERDOUT3± power-down.	0x0	R/W
		2	JESD204B Lane 2 power-down	0 1	Physical Lane 2 force power-down. SERDOUT2± normal operation. SERDOUT2± power-down.	0x0	R/W

Addr.	Name	Bit(s)	Bit Name	Setting	Description	Reset	Access
		1	JESD204B Lane 1 power-down	0 1	Physical Lane 1 force power-down. SERDOUT1± normal operation. SERDOUT1± power-down.	0x0	R/W
		0	JESD204B Lane 0 power-down	0 1	Physical Lane 0 force power-down. SERDOUT0± normal operation. SERDOUT0± power-down.	0x0	R/W
0x05B2	JESD204B Lane Assign 1	7	Reserved		Reserved.	0x0	R
		[6:4]	SERDOUT1± lane assignment	000 001 010 011 100 101 110 111	Physical Lane 1 assignment. Logical Lane 0. Logical Lane 1 (default). Logical Lane 2. Logical Lane 3. Logical Lane 4. Logical Lane 5. Logical Lane 6. Logical Lane 7.	0x1	R/W
		3	Reserved		Reserved.	0x0	R
		[2:0]	SERDOUT0± lane assignment	000 001 010 011 100 101 110 111	Physical Lane 0 assignment. Logical Lane 0 (default). Logical Lane 1. Logical Lane 2. Logical Lane 3. Logical Lane 4. Logical Lane 5. Logical Lane 6. Logical Lane 7.	0x0	R/W
0x05B3	JESD204B Lane Assign 2	7	Reserved		Reserved.	0x0	R
		[6:4]	SERDOUT3± lane assignment	000 001 010 011 100 101 110 111	Physical Lane 3 assignment. Logical Lane 0. Logical Lane 1. Logical Lane 2. Logical Lane 3 (default). Logical Lane 4. Logical Lane 5. Logical Lane 6. Logical Lane 7.	0x3	R/W
		3	Reserved		Reserved.	0x0	R
		[2:0]	SERDOUT2± lane assignment	000 001 010 011 100 101 110 111	Physical Lane 2 assignment. Logical Lane 0. Logical Lane 1. Logical Lane 2 (default). Logical Lane 3. Logical Lane 4. Logical Lane 5. Logical Lane 6. Logical Lane 7.	0x2	R/W

Addr.	Name	Bit(s)	Bit Name	Setting	Description	Reset	Access	
0x05B5	JESD204B Lane Assign 3	7	Reserved		Reserved.	0x0	R	
		[6:4]	SERDOUT5± lane assignment		Physical Lane 5 assignment.	0x5	R/W	
				000	Logical Lane 0.			
				001	Logical Lane 1.			
				010	Logical Lane 2.			
				011	Logical Lane 3.			
				100	Logical Lane 4.			
				101	Logical Lane 5 (default).			
				110	Logical Lane 6.			
				111	Logical Lane 7.			
		3	Reserved		Reserved.	0x0	R	
		[2:0]	SERDOUT4± lane assignment		Physical Lane 4 assignment.	0x4	R/W	
				000	Logical Lane 0.			
				001	Logical Lane 1.			
				010	Logical Lane 2.			
				011	Logical Lane 3.			
				100	Logical Lane 4 (default).			
				101	Logical Lane 5.			
				110	Logical Lane 6.			
				111	Logical Lane 7.			
0x05B6	JESD204B Lane Assign 4	7	Reserved		Reserved.	0x0	R	
		[6:4]	SERDOUT7± lane assignment		Physical Lane 7 assignment.	0x7	R/W	
				000	Logical Lane 0.			
				001	Logical Lane 1.			
				010	Logical Lane 2.			
				011	Logical Lane 3.			
				100	Logical Lane 4.			
				101	Logical Lane 5.			
				110	Logical Lane 6.			
				111	Logical Lane 7 (default).			
		3	Reserved		Reserved.	0x0	R	
		[2:0]	SERDOUT6± lane assignment		Physical Lane 6 assignment.	0x6	R/W	
				000	Logical Lane 0.			
				001	Logical Lane 1.			
				010	Logical Lane 2.			
				011	Logical Lane 3.			
				100	Logical Lane 4.			
				101	Logical Lane 5.			
				110	Logical Lane 6 (default).			
				111	Logical Lane 7.			
0x05BF	SERDOUTx± data invert	7	Invert SERDOUT7± data		Invert SERDOUT7± data.	0x0	R/W	
				0	Normal.			
				1	Invert.			
		6	Invert SERDOUT6± data		Invert SERDOUT6± data.	0x0	R/W	
				0	Normal.			
				1	Invert.			
		5	Invert SERDOUT5± data		Invert SERDOUT5± data.	0x0	R/W	
				0	Normal.			
				1	Invert.			
		4	Invert SERDOUT4± data		Invert SERDOUT4± data.	0x0	R/W	
				0	Normal.			
				1	Invert.			

Addr.	Name	Bit(s)	Bit Name	Setting	Description	Reset	Access
		3	Invert SERDOUT3± data	0 1	Invert SERDOUT3± data. Normal. Invert.	0x0	R/W
		2	Invert SERDOUT2± data	0 1	Invert SERDOUT2± data. Normal. Invert.	0x0	R/W
		1	Invert SERDOUT1± data	0 1	Invert SERDOUT1± data. Normal. Invert.	0x0	R/W
		0	Invert SERDOUT0± data	0 1	Invert SERDOUT0± data. Normal. Invert.	0x0	R/W
0x05C0	JESD204B Swing Adjust 1	7	Reserved		Reserved.	0x0	R
		[6:4]	SERDOUT1± voltage swing adjust	000 001 010	Output swing level for SERDOUT1±. 1.0 × DRVDD1. 0.850 × DRVDD1. 0.750 × DRVDD1.	0x1	R/W
		3	Reserved		Reserved.	0x0	R
		[2:0]	SERDOUT0± voltage swing adjust	000 001 010	Output swing level for SERDOUT0±. 1.0 × DRVDD1. 0.850 × DRVDD1. 0.750 × DRVDD1.	0x1	R/W
0x05C1	JESD204B Swing Adjust 2	7	Reserved		Reserved.	0x0	R
		[6:4]	SERDOUT3± voltage swing adjust	000 001 010	Output swing level for SERDOUT3±. 1.0 × DRVDD1. 0.850 × DRVDD1. 0.750 × DRVDD1.	0x1	R/W
		3	Reserved		Reserved.	0x0	R
		[2:0]	SERDOUT2± voltage swing adjust	000 001 010	Output swing level for SERDOUT2±. 1.0 × DRVDD1. 0.850 × DRVDD1. 0.750 × DRVDD1.	0x1	R/W
0x05C2	JESD204B Swing Adjust 3	7	Reserved		Reserved.	0x0	R
		[6:4]	SERDOUT5± voltage swing adjust	000 001 010	Output swing level for SERDOUT5±. 1.0 × DRVDD1. 0.850 × DRVDD1. 0.750 × DRVDD1.	0x1	R/W
		3	Reserved		Reserved.	0x0	R
		[2:0]	SERDOUT4± voltage swing adjust	000 001 010	Output swing level for SERDOUT4±. 1.0 × DRVDD1. 0.850 × DRVDD1. 0.750 × DRVDD1.	0x1	R/W
0x05C3	JESD204B Swing Adjust 4	7	Reserved		Reserved.	0x0	R
		[6:4]	SERDOUT7± voltage swing adjust	000 001 010	Output swing level for SERDOUT7±. 1.0 × DRVDD1. 0.850 × DRVDD1. 0.750 × DRVDD1.	0x1	R/W
		3	Reserved		Reserved.	0x0	R

Addr.	Name	Bit(s)	Bit Name	Setting	Description	Reset	Access
		[2:0]	SERDOUT6± voltage swing adjust	000 001 010	Output swing level for SERDOUT6±. 1.0 × DRVDD1. 0.850 × DRVDD1. 0.750 × DRVDD1.	0x1	R/W
0x05C4	SERDOUT0 de-emphasis select	7	Posttap enable	0 1	Posttap enable. Disable. Enable.	0x0	R/W
		[6:4]	Set posttap level for SERDOUT0±	000 001 010 011 100	Set posttap level. 0 dB. 3 dB. 6 dB. 9 dB. 12 dB.	0x0	R/W
		[3:0]	Reserved		Reserved.	0x0	R/W
0x05C5	SERDOUT1 de-emphasis select	7	Posttap enable	0 1	Posttap enable. Disable. Enable.	0x0	R/W
		[6:4]	Set posttap level for SERDOUT1±	000 001 010 011 100	Set posttap level. 0 dB. 3 dB. 6 dB. 9 dB. 12 dB.	0x0	R/W
		[3:0]	Reserved		Reserved.	0x0	R/W
0x05C6	SERDOUT2 de-emphasis select	7	Posttap enable	0 1	Posttap enable. Disable. Enable.	0x0	R/W
		[6:4]	Set posttap level for SERDOUT2±	000 001 010 011 100	Set posttap level. 0 dB. 3 dB. 6 dB. 9 dB. 12 dB.	0x0	R/W
		[3:0]	Reserved		Reserved.	0x0	R/W
0x05C7	SERDOUT3 de-emphasis select	7	Posttap enable	0 1	Posttap enable. Disable. Enable.	0x0	R/W
		[6:4]	Set posttap level for SERDOUT3±	000 001 010 011 100	Set posttap level. 0 dB. 3 dB. 6 dB. 9 dB. 12 dB.	0x0	R/W
		[3:0]	Reserved		Reserved.	0x0	R/W

Addr.	Name	Bit(s)	Bit Name	Setting	Description	Reset	Access
0x05C8	SERDOUT4 de-emphasis select	7	Posttap enable		Posttap enable.	0x0	R/W
				0	Disable.		
		1	Enable.				
		[6:4]	Set posttap level for SERDOUT4±		Set posttap level.	0x0	R/W
		000	0 dB.				
		001	3 dB.				
		010	6 dB.				
		011	9 dB.				
		100	12 dB.				
[3:0]	Reserved		Reserved.	0x0	R/W		
0x05C9	SERDOUT5 preemphasis select	7	Posttap enable		Posttap enable.	0x0	R/W
				0	Disable.		
		1	Enable.				
		[6:4]	Set posttap level for SERDOUT5±		Set posttap level.	0x0	R/W
		000	0 dB.				
		001	3 dB.				
		010	6 dB.				
		011	9 dB.				
		100	12 dB.				
[3:0]	Reserved		Reserved.	0x0	R/W		
0x05CA	SERDOUT6 preemphasis select	7	Posttap enable		Posttap enable.	0x0	R/W
				0	Disable.		
		1	Enable.				
		[6:4]	Set posttap level for SERDOUT6±		Set posttap level.	0x0	R/W
		000	0 dB.				
		001	3 dB.				
		010	6 dB.				
		011	9 dB.				
		100	12 dB.				
[3:0]	Reserved		Reserved.	0x0	R/W		
0x05CB	SERDOUT7 preemphasis select	7	Posttap enable		Posttap enable.	0x0	R/W
				0	Disable.		
		1	Enable.				
		[6:4]	Set posttap level for SERDOUT7±		Set posttap level.	0x0	R/W
		000	0 dB.				
		001	3 dB.				
		010	6 dB.				
		011	9 dB.				
		100	12 dB.				
[3:0]	Reserved		Reserved.	0x0	R/W		
0x1222	JESD204B PLL calibration	[7:0]	JESD204B PLL calibration reset		See Table 32.	0x00	R/W
				0x00	JESD204B PLL normal operation.		
				0x04	Reset JESD204B PLL calibration.		
0x1228	JESD204B PLL startup control	[7:0]	JESD204B PLL calibration startup circuit reset		See Table 32.	0x0F	R/W
				0x0F	JESD204B start-up circuit in normal operation.		
				0x4F	Reset JESD204B startup circuit.		

Addr.	Name	Bit(s)	Bit Name	Setting	Description	Reset	Access
0x1262	JESD204B PLL LOL bit control	[7:0]	JESD204B PLL loss of lock bit clear	0x00 0x80	See Table 32. Loss of lock bit normal operation. Clear loss of lock bit.	0x00	R/W

Programmable Filter (PFILT) Control and Coefficients Registers

Table 52.

Addr.	Name	Bit(s)	Bit Name	Setting	Description	Reset	Access
0x0DF8	Programmable filter control	[7:3]	Reserved		Reserved.	0x0	R
		[2:0]	Programmable filter mode		PFILT mode. The asterisk symbol (*) denotes convolution.	0x0	R/W
				000	Disabled (filters bypassed).		
				001	Single filter (X only). $DOUT_I[n] = DIN_I[n] * X_I[n]$ $DOUT_Q[n] = DIN_Q[n] * X_Q[n]$		
				010	Single filter (X and Y together) $DOUT_I[n] = DIN_I[n] * XY_I[n]$ $DOUT_Q[n] = DIN_Q[n] * XY_Q[n]$		
				100	Cascaded filters (X to Y). $DOUT_I[n] = DIN_I[n] * X_I[n] * Y_I[n]$ $DOUT_Q[n] = DIN_Q[n] * X_Q[n] * Y_Q[n]$ $DOUT_Q[n] = DIN_Q[n] * X_Q[n] * Y_Q[n]$		
				101	Complex filters. $DOUT_I[n] = DIN_I[n] * X_I[n] + DIN_Q[n] * Y_Q[n]$ $DOUT_Q[n] = DIN_Q[n] * X_Q[n] + DIN_I[n] * Y_I[n]$		
				110	Half complex filter. $DOUT_I[n] = DIN_I[n]$ $DOUT_Q[n] = DIN_Q[n] * XY_Q[n] + DIN_I[n] * XY_I[n]$		
111	Real 96-tap filter. $DOUT_I[n] = DIN_I[n] * XY_I[n]$. $DOUT_Q[n] = DIN_Q[n] * XY_Q[n]$						
0x0DF9	PFILT gain	7	Reserved		Reserved.	0x0	R
		[6:4]	PFILT Y gain	110	-12 dB loss.	0x0	R/W
				111	-6 dB loss.		
				000	0 dB gain.		
				001	+6 dB gain.		
010	+12 dB gain.						
3	Reserved		Reserved.	0x0	R		
[2:0]	PFILT X gain	110	-12 dB loss.	0x0	R/W		
		111	-6 dB loss.				
		000	0 dB gain.				
		001	+6 dB gain.				
		010	+12 dB gain.				
0x0E00 to 0x0E7F	Programmable Filter X Coefficient x	[7:0]	Programmable Filter X Coefficient 0 to 127		Refer to the I coefficient table (Table 14) and the Q coefficient table (Table 15) in the Programmable FIR Filters section for details. Coefficients are only applied after the chip transfer bit (Register 0x000F, Bit 0) is set.	0x0	R/W
0x0F00 to 0x0F7F	Programmable Filter Y Coefficient x	[7:0]	Programmable Filter Y Coefficient 0 to 127		Refer to the I coefficient table (Table 14) and the Q coefficient table (Table 15) in the Programmable FIR Filters section for details. Coefficients are only applied after the chip transfer bit (Register 0x000F, Bit 0) is set.	0x0	R/W

VREF/Analog Input Control Registers

Table 53.

Addr.	Name	Bit(s)	Bit Name	Setting	Description	Reset	Access
0x0701	DC offset calibration control (local)	[7:0]	DC offset calibration control	0x06 0x86	Disable. Enable.	0x06	R/W
0x073B	DC Offset Calibration Control 2 (local)	[7:0]	DC offset calibration accumulator reset	0xB7 0x37	Synchronously reset dc offset calibration accumulator. Accumulator held in reset (use when 0x0701 = 0x06). Accumulator reset released (use when 0x0701 = 0x86).	0xB7	R/W
0x18A6	VREF control	[7:1]	Reserved		Reserved.	0x0	R
		0	VREF control	0 1	Internal reference. External reference.	0x0	R/W
0x18E3	External V _{CM} buffer control	7	Reserved		Reserved.	0x0	R
		6	External V _{CM} buffer	0 1	Disable. Enable.	0x0	R/W
		[5:0]	External V _{CM} buffer[5:0]		See the Input Common Mode section.	0x0	R/W
0x18E6	Temperature diode export	[7:0]	Temperature diode location select	0x00 0x01 0x02 0x03 0x40 0x41 0x42 0x43 0x50 0x51 0x52 0x53	Central diode output. VREF pin = high-Z. Central diode output. VREF pin = 1× diode voltage output. Central diode output. VREF pin = 20× diode voltage output. Central diode output. VREF pin = GND. Channel A diode output. VREF pin = high-Z. Channel A diode output. VREF pin = 1× diode voltage output. Channel A diode output. VREF pin = 20× diode voltage output. Channel A diode output. VREF pin = GND. Channel B diode output VREF pin = high-Z. Channel B diode output VREF pin = 1× diode voltage output. Channel B diode output VREF pin = 20× diode voltage output. Channel B diode output VREF pin = GND.	0x0	R/W
0x1908	Analog input control (local)	[7:3]	Reserved		Reserved.	0x0	R
		2	Enable dc coupling	0 1	Analog input is optimized for ac coupling. Analog input is optimized for dc coupling.	0x0	R/W
		[1:0]	Reserved		Reserved.	0x0	R
0x1910	Input full-scale control (local)	[7:4]	Reserved		Reserved.	0x0	R
		[3:0]	Full-scale voltage	1000 1001 1101 1110 1111 0000	Full-scale voltage setting. 1.13 V p-p differential. 1.25 V p-p differential. 1.7 V p-p differential. 1.81 V p-p differential. 1.93 V p-p differential. 2.04 V p-p differential.	0xD	R/W

Addr.	Name	Bit(s)	Bit Name	Setting	Description	Reset	Access
0x1A48	High frequency setting (local)	[7:0]	High frequency setting	0x14 0x54	First Nyquist operation. Second or higher Nyquist operation.	0x14	R/W
0x1A4C	Buffer Control 1 (local)	[7:6]	Reserved		Reserved.	0x0	R
		[5:0]	Buffer Control 1	00 1111 00 0100 00 1001 01 1110 10 0011 10 1000 10 1101 11 0010	Input Buffer Main Current 1. See the Analog Input Buffer Controls and SFDR Optimization section. Buffer current set to 300 μ A Buffer current set to 400 μ A. Buffer current set to 500 μ A. Buffer current set to 600 μ A. Buffer current set to 700 μ A. Buffer current set to 800 μ A. Buffer current set to 900 μ A. Buffer current set to 1000 μ A.	0x0F	R/W
0x1A4D	Buffer Control 2 (local)	[7:6]	Reserved		Reserved.	0x0	R
		[5:0]	Buffer Control 2	00 1111 00 0100 00 1001 01 1110 10 0011 10 1000 10 1101 11 0010	Input Buffer Main Current 2. See the Analog Input Buffer Controls and SFDR Optimization section. Buffer current set to 300 μ A Buffer current set to 400 μ A. Buffer current set to 500 μ A. Buffer current set to 600 μ A. Buffer current set to 700 μ A. Buffer current set to 800 μ A. Buffer current set to 900 μ A. Buffer current set to 1000 μ A.	0x0F	R/W

APPLICATIONS INFORMATION

POWER SUPPLY RECOMMENDATIONS

The power supplies required to power the AD9689 are shown in Table 54. A power-on sequence is not required to operate the AD9689. The power supply domains can be powered up in any order.

Table 54. Typical Power Supplies for the AD9689

Domain	Voltage (V)	Tolerance (%)
AVDD1	0.975	±2.5
AVDD1_SR	0.975	±2.5
DVDD	0.975	±2.5
DRVDD1	0.975	±2.5
AVDD2	1.9	±2.5
DRVDD2	1.9	±2.5
SPIVDD	1.9	±2.5
AVDD3	2.5	±2.5

For applications requiring an optimal high power efficiency and low noise performance, it is recommended that the ADP5054 quad switching regulator be used to convert an input voltage in the 6.0 V to 15 V range to intermediate rails (1.3 V, 2.4 V, and 3.0 V). These intermediate rails are then postregulated by very low noise, low dropout (LDO) regulators (ADP1763, ADP7159, and LT3045). Figure 157 shows the recommended power supply scheme for the AD9689.

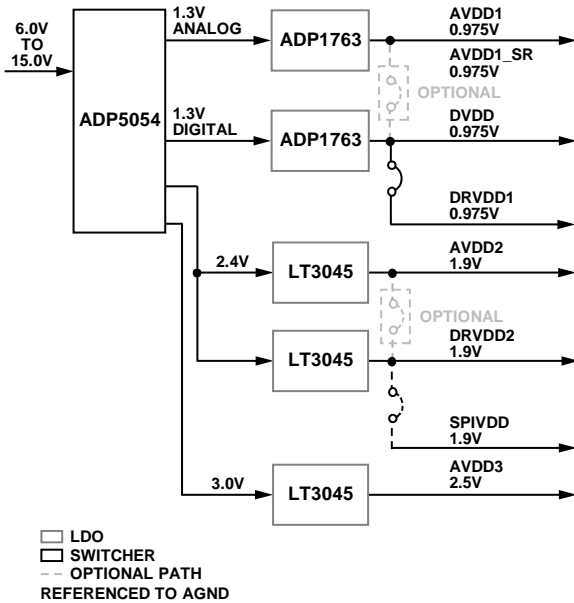

Figure 157. High Efficiency, Low Noise Power Solution for the AD9689

It is not necessary to split all of these power domains in all cases. The recommended solution shown in Figure 157 provides the lowest noise, highest efficiency power delivery system for the AD9689. If only one 0.975 V supply is available, route to AVDD1 first and then tap it off and isolate it with a ferrite bead or a filter choke, preceded by decoupling capacitors for AVDD1_SR, DVDD, and DRVDD1, in that order. Figure 158 shows the simplified schematic. The dc resistance (DCR) of the ferrite bead must be taken into consideration when choosing the appropriate ferrite bead. Otherwise, excessive loss across the ferrite bead can lead to a malfunctioning ADC. Adjustable LDOs can be employed to output a higher voltage to account for the drop across the ferrite bead.

Alternatively, the LDOs can be bypassed altogether and the AD9689 can be driven directly from the dc-to-dc converter. Note that this approach has risks in that there may be more power supply noise inserted into the power supply domains of the ADC. To minimize noise, follow the layout guidelines of the dc-to-dc converter.

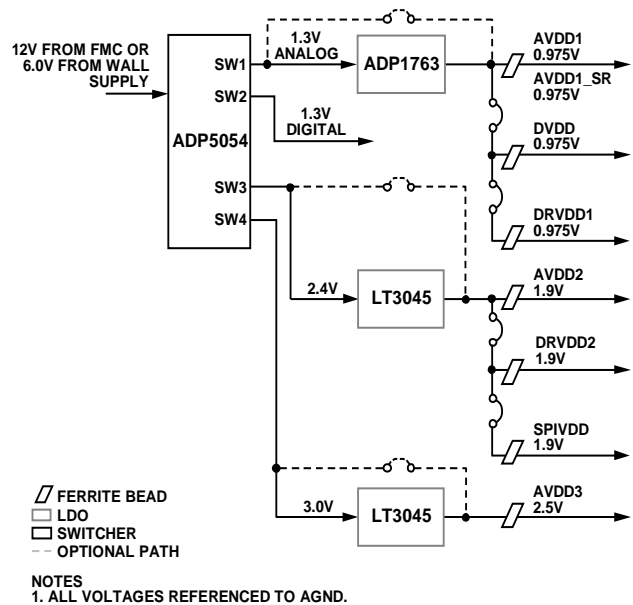

Figure 158. Simplified Power Solution for the AD9689

The user can employ several different decoupling capacitors to cover both high and low frequencies. These capacitors must be located close to the point of entry at the PCB level and close to the devices, with minimal trace lengths.

LAYOUT GUIDELINES

The ADC evaluation board can be used as a guide to follow good layout practices. The evaluation board layout is set up in such a way as to

- Minimize coupling between the analog inputs (Channel A to Channel B and Channel B to Channel A).
- Minimize clock coupling to the analog inputs.
- Provide enough power and ground planes for the various supply domains while reducing cross coupling.
- Provide adequate thermal relief to the ADC.

Figure 159 shows the overall layout scheme used for the AD9689 evaluation boards.

AVDD1_SR (PIN E7) AND AGND (PIN E6 AND PIN E8)

Use AVDD1_SR (Pin E7) and AGND (Pin E6 and Pin E8) to provide a separate power supply node to the SYSREF± circuits of the AD9689. If running in Subclass 1, the AD9689 can support periodic one-shot or gapped signals. To minimize the coupling of this supply into the AVDD1 supply node, adequate supply bypassing is needed.

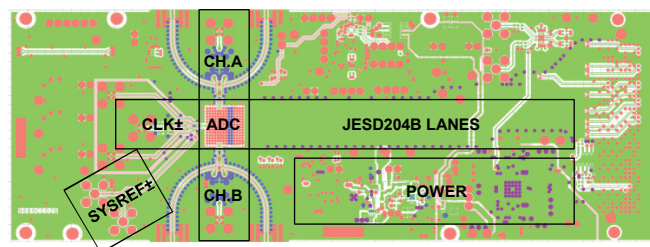
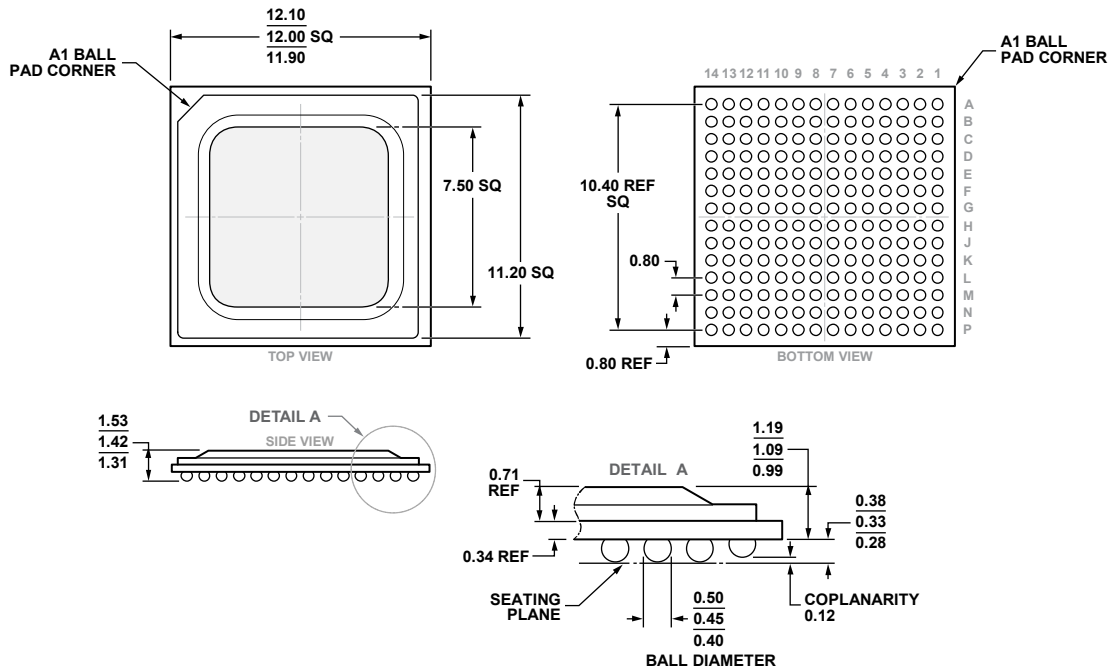

Figure 159. Recommended PCB Layout for the AD9689

OUTLINE DIMENSIONS



COMPLIANT TO JEDEC STANDARDS MO-275-GGAB-1.

Figure 160. 196-Ball Ball Grid Array, Thermally Enhanced [BGA_ED]
 12 mm × 12 mm (BP-196-4)
 Dimensions shown in millimeters



ORDERING GUIDE

Model ¹	Temperature Range	Package Description	Package Option
AD9689BBPZ-2000	-40°C to +85°C	196-Ball Ball Grid Array, Thermally Enhanced [BGA_ED]	BP-196-4
AD9689BBPZRL-2000	-40°C to +85°C	196-Ball Ball Grid Array, Thermally Enhanced [BGA_ED]	BP-196-4
AD9689BBPZ-2600	-40°C to +85°C	196-Ball Ball Grid Array, Thermally Enhanced [BGA_ED]	BP-196-4
AD9689BBPZRL-2600	-40°C to +85°C	196-Ball Ball Grid Array, Thermally Enhanced [BGA_ED]	BP-196-4
AD9689-2000EBZ		Evaluation Board	
AD9689-2600EBZ		Evaluation Board	

¹ Z = RoHS Compliant Part.

Looking for pricing, stock, or lifecycle information?

Click below to explore more details on WIN SOURCE:

-  View [AD9689BBPZ-2600](#) on WIN SOURCE
-  [Analog Devices Inc.](#) Information

Optimize Your Supply Chain with WIN SOURCE Solutions

-  Global Sourcing Solution
-  Obsolete Management
-  Cost Control Management
-  Shortage Management
-  Alternative Solution
-  Excess Inventory Management