



**THE DATASHEET OF
SLG59M301V**



SLG59M301V

An Ultra-small 3 mm², 8.5 mΩ, 4 A, Internally-protected Load Switch

General Description

The SLG59M301V is a high performance 8.5 mΩ, 4 A single-channel nFET load switch which can operate with a 2.5 V to 5.5 V V_{DD} supply to switch power rails from as low as 0.85 V up to the supply voltage. The SLG59M301V incorporates two-level overload current protection, thermal shutdown protection, and inrush current control which can easily be adjusted by a small external capacitor.

Using a proprietary MOSFET design, the SLG59M301V achieves a stable 8.5 mΩ RDS_{ON} across a wide input voltage range. In addition, the SLG59M301V's package also exhibits low thermal resistance for high-current operation using Renesas's advanced assembly technology.

Fully specified over the -40 °C to 85 °C temperature range, the SLG59M301V is packaged in a space-efficient, low thermal resistance, RoHS-compliant 1.5 mm x 2.0 mm STDFN package.

Features

- 1.5 x 2.0 mm FC-TDFN 8L package (2 fused pins for drain and 2 fused pins for source)
- Logic level ON pin capable of supporting 0.85 V CMOS Logic
- User selectable ramp rate with external capacitor
- 8.5 mΩ RDS_{ON} while supporting 4 A
- Discharges load when off
- Two Over Current Protection Modes
 - Short Circuit Current Limit
 - Active Current Limit
- Over Temperature Protection
- Pb-Free / Halogen-Free / RoHS compliant
- Operating Temperature: -40 °C to 85°C
- Operating Voltage: 2.5 V to 5.5 V

Pin Configuration

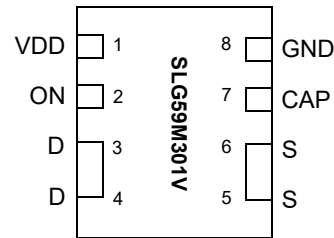

8-pin FC-TDFN (Top View)

Applications

- Notebook Power Rail Switching
- Tablet Power Rail Switching
- Smartphone Power Rail Switching

Block Diagram

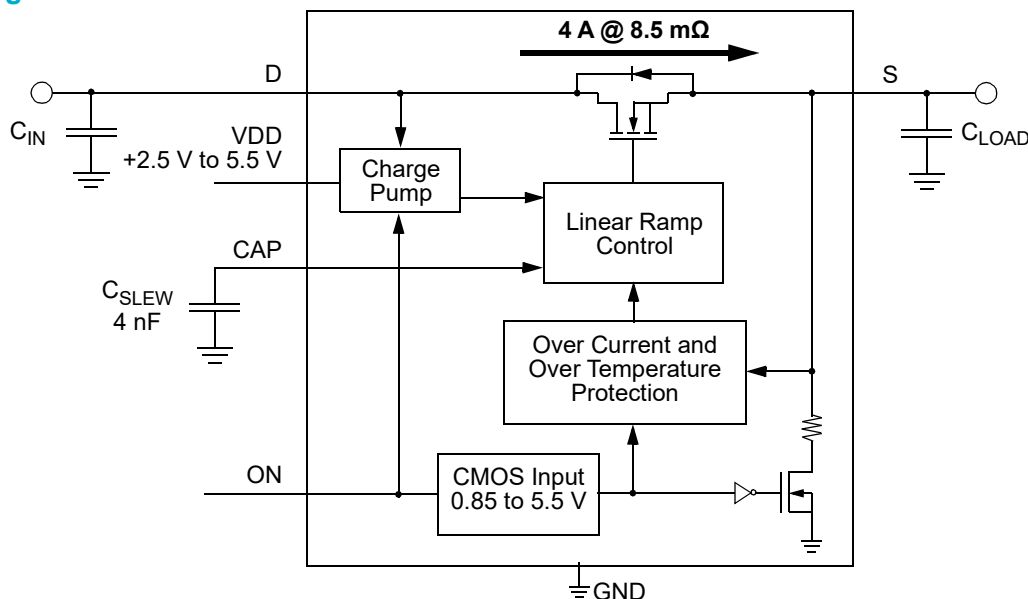

SLG59M301V

An Ultra-small 3 mm², 8.5 mΩ, 4 A,
Internally-protected Load Switch

Pin Description

Pin #	Pin Name	Type	Pin Description
1	VDD	PWR	VDD supplies the power for the operation of the load switch and internal control circuitry. Bypass the VDD pin to GND with a 0.1 μF (or larger) capacitor.
2	ON	Input	A low-to-high transition on this pin initiates the operation of the SLG59M301V's state machine. ON is a CMOS input with ON_V _{IL} < 0.3 V and ON_V _{IH} > 0.85 V thresholds. While there is an internal pull-down circuit to GND (~4 MΩ), connect this pin directly to a general-purpose output (GPO) of a microcontroller, an application processor, or a system controller.
3, 4	D	MOSFET	Drain terminal connection of the n-channel MOSFET (2 pins fused for V _D). Connect at least a low-ESR 0.1 μF capacitor from this pin to ground. Capacitors used at D should be rated at 10 V or higher.
5, 6	S	MOSFET	Source terminal connection of the n-channel MOSFET (2 pins fused for V _S). Connect a low-ESR capacitor from this pin to ground and consult the Electrical Characteristics table for recommended C _{LOAD} range. Capacitors used at S should be rated at 10 V or higher.
7	CAP	Input	A low-ESR, stable dielectric, ceramic surface-mount capacitor connected from CAP pin to GND sets the V _S slew rate and overall turn-on time of the SLG59M301V. For best performance C _{SLEW} value should be ≥ 1.5 nF and voltage level should be rated at 10 V or higher.
8	GND	GND	Ground connection. Connect this pin to system analog or power ground plane.

Ordering Information

Part Number	Type	Production Flow
SLG59M301V	FC-TDFN 8L	Industrial, -40 °C to 85 °C
SLG59M301VTR	FC-TDFN 8L (Tape and Reel)	Industrial, -40 °C to 85 °C

SLG59M301V

An Ultra-small 3 mm², 8.5 mΩ, 4 A,
Internally-protected Load Switch

Absolute Maximum Ratings

Parameter	Description	Conditions	Min.	Typ.	Max.	Unit
V _{DD}	Power Supply		--	--	7	V
V _D to GND	Load Switch Input Voltage to GND		-0.3	--	V _{DD}	V
V _S to GND	Load Switch Output Voltage to GND		-0.3	--	V _D	V
ON and CAP to GND	ON and CAP Pin Voltages to GND		-0.3	--	V _{DD}	V
T _S	Storage Temperature		-65	--	150	°C
ESD _{HBM}	ESD Protection	Human Body Model	2000	--	--	V
ESD _{CDM}	ESD Protection	Charged Device Model	1000	--	--	V
MSL	Moisture Sensitivity Level		1			
θ _{JA}	Thermal Resistance	1.5 x 2mm, 8L TDFN; Determined using 1 in ² , 1 oz. copper pads under each D and S terminals and FR4 pcb material	--	85	--	°C/W
W _{DIS}	Package Power Dissipation		--	--	1	W
MOSFET IDS _{PK}	Peak Current from Drain to Source	For no more than 1 ms with 1% duty cycle	--	--	6	A

Note: Stresses greater than those listed under "Absolute Maximum Ratings" may cause permanent damage to the device. This is a stress rating only and functional operation of the device at these or any other conditions above those indicated in the operational sections of this specification is not implied. Exposure to absolute maximum rating conditions for extended periods may affect reliability.

Electrical Characteristics

T_A = -40 °C to 85 °C unless otherwise noted.

Parameter	Description	Conditions	Min.	Typ.	Max.	Unit
V _{DD}	Power Supply Voltage	-40 °C to 85 °C	2.5	--	5.5	V
I _{DD}	Power Supply Current (PIN 1)	when OFF	--	--	1	μA
		when ON, No load	--	70	105	μA
RDS _{ON}	ON Resistance	T _A 25°C, I _{DS} = 100 mA	--	8.5	10.3	mΩ
		T _A 85°C, I _{DS} = 100 mA	--	10	12	mΩ
MOSFET IDS	Current from D to S	Continuous	--	--	4	A
V _D	Drain Voltage		0.85	--	V _{DD}	V
I _{FET_OFF}	MOSFET OFF Leakage Current	2.5 V ≤ V _{DD} ≤ 5.5 V; V _S = 0 V; ON = LOW; T _A = 25°C	--	--	1	μA
T _{ON_Delay}	ON Delay Time	50% ON to V _S Ramp Start	--	300	500	μs
T _{Total_ON}	Total Turn On Time	50% ON to 90% V _S	Set by External C _{SLEW} ¹			ms
		Example: C _{SLEW} = 4 nF, V _{DD} = V _D = 5 V, C _{LOAD} = 10 μF, R _{LOAD} = 20 Ω	--	1.8	--	ms
V _{S(SR)}	Slew Rate	10% V _S to 90% V _S	Set by External C _{SLEW} ¹			V/ms
		Example: C _{SLEW} = 4 nF, V _{DD} = V _D = 5 V, C _{LOAD} = 10 μF, R _{LOAD} = 20 Ω	--	3.0	--	V/ms
C _{LOAD}	Output Load Capacitance	C _{LOAD} connected from S to GND	--	10	500	μF
R _{DISCHARGE}	Discharge Resistance		100	200	300	Ω
ON_V _{IH}	High Input Voltage on ON pin		0.85	--	V _{DD}	V

SLG59M301V

An Ultra-small 3 mm², 8.5 mΩ, 4 A,
Internally-protected Load Switch

Electrical Characteristics (continued)

T_A = -40 °C to 85 °C unless otherwise noted.

Parameter	Description	Conditions	Min.	Typ.	Max.	Unit
ON_V _{IL}	Low Input Voltage on ON pin		-0.3	0	0.3	V
I _{LIMIT}	Active Current Limit, I _{ACL}	MOSFET will automatically limit current when V _S > 250 mV	--	6.0	--	A
	Short Circuit Current Limit, I _{SC} L	MOSFET will automatically limit current when V _S < 250 mV	--	0.5	--	A
THERM _{ON}	Thermal shutoff turn-on temperature		--	125	--	°C
THERM _{OFF}	Thermal shutoff turn-off temperature		--	100	--	°C
THERM _{TIME}	Thermal shutoff time		--	--	1	ms
T _{OFF_Delay}	OFF Delay Time	50% ON to V _S Fall Start, V _{DD} = V _D = 5 V, R _{LOAD} = 20 Ω, no C _{LOAD}	--	--	32	μs

Notes:

1. Refer to typical timing parameter vs. C_{SLEW} performance charts for additional information when available.

T_{ON_Delay}, V_{S(SR)}, and T_{Total_ON} Timing Details

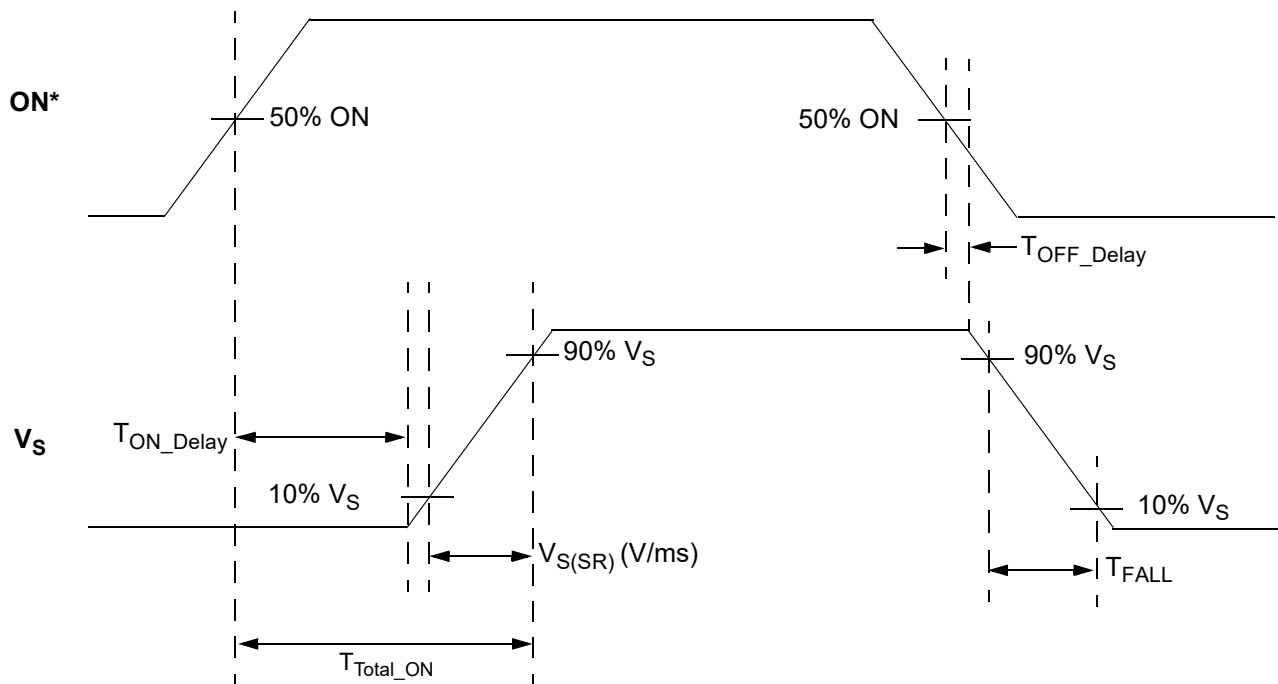

Note: * Rise and Fall times of the ON signal are 100 ns

SLG59M301V

An Ultra-small 3 mm², 8.5 mΩ, 4 A, Internally-protected Load Switch

Typical Performance Characteristics

T_{Total_ON} vs C_{SLEW}, V_D, V_{DD}, and Temperature

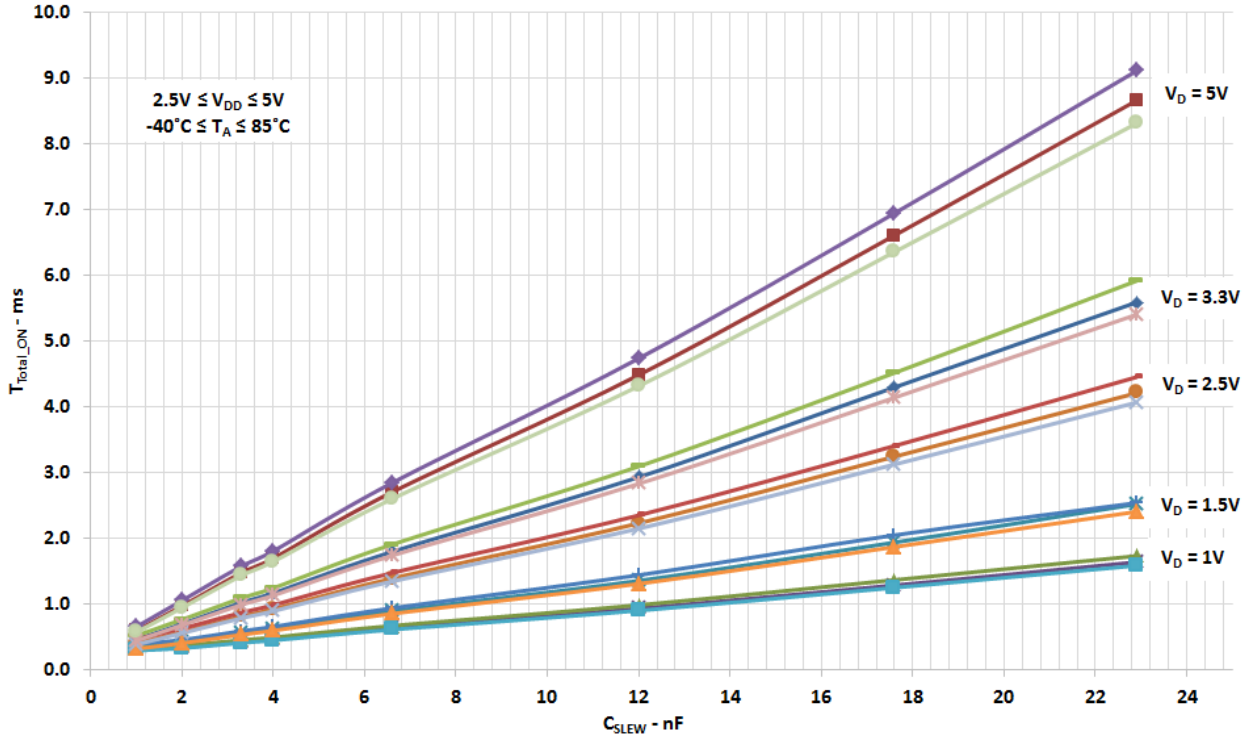

RDS_{ON} vs. Temperature, V_{DD}, and V_{IN}

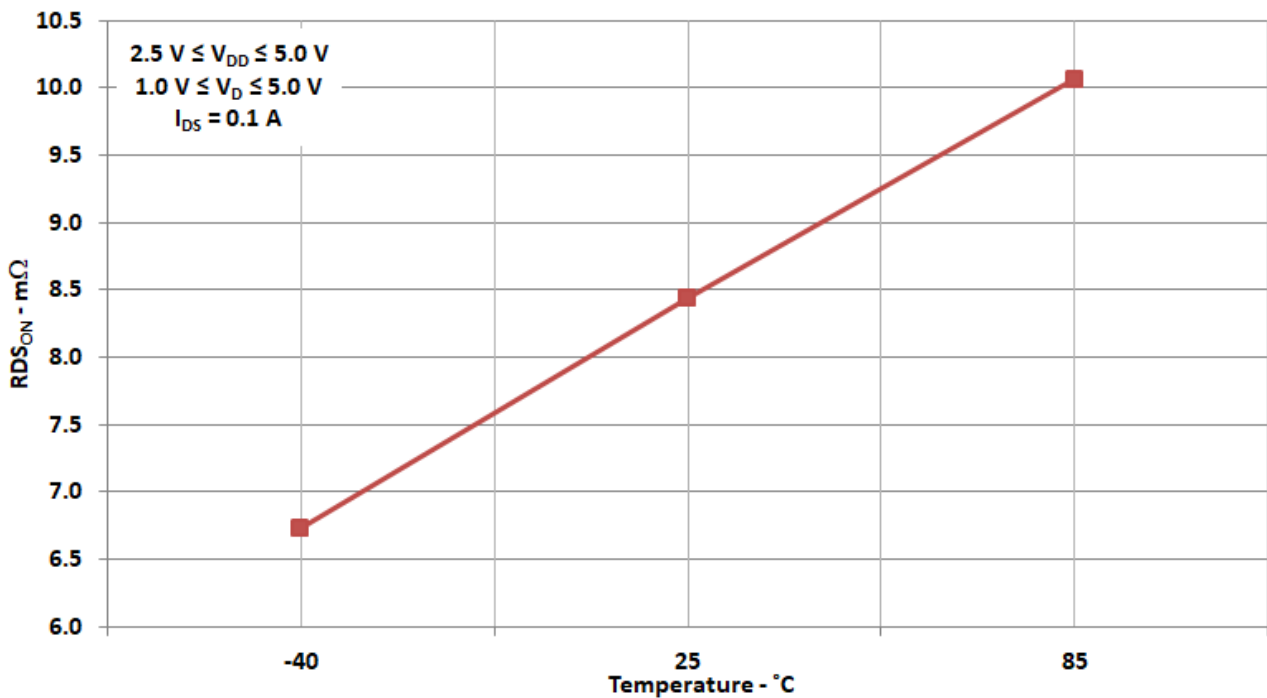

SLG59M301V

An Ultra-small 3 mm², 8.5 mΩ, 4 A,
Internally-protected Load Switch

V_S Slew Rate vs. C_{SL}, V_{DD}, and Temperature

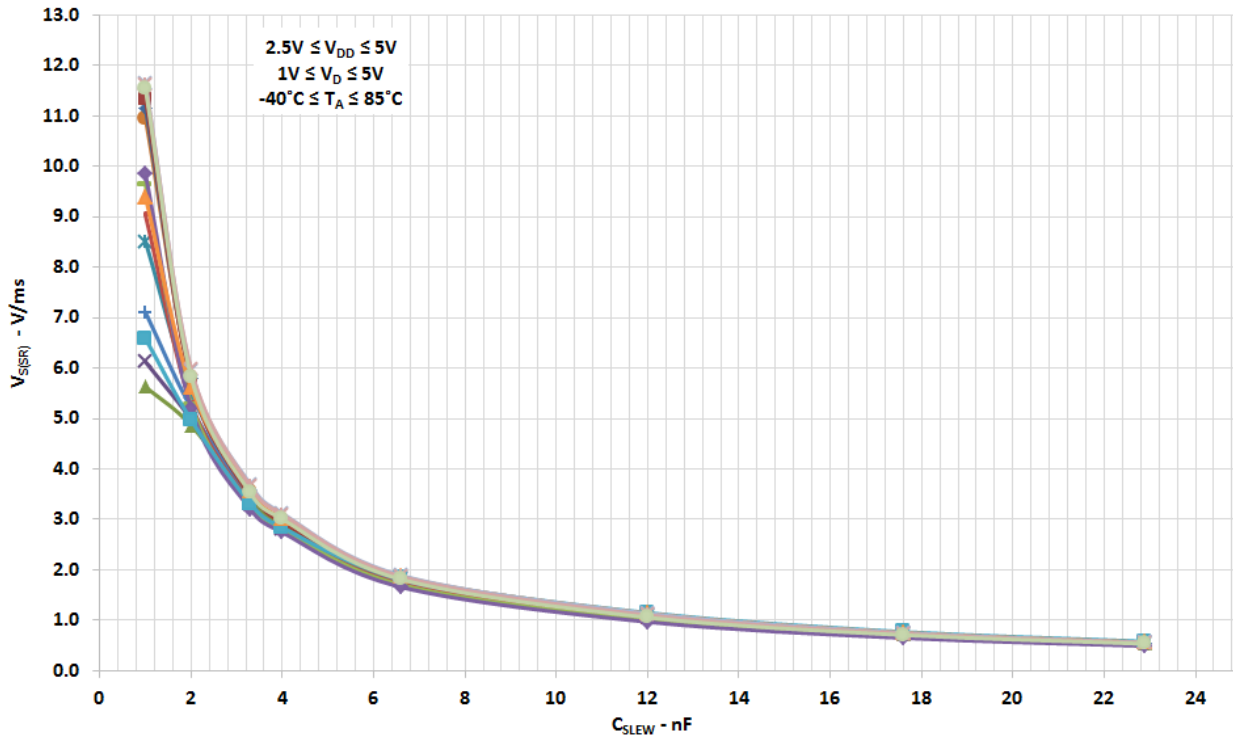

SLG59M301V

An Ultra-small 3 mm², 8.5 mΩ, 4 A,
Internally-protected Load Switch

SLG59M301V Power-Up/Power-Down Sequence Considerations

To ensure glitch-free power-up under all conditions, apply V_{DD} first, followed by V_D after V_{DD} exceeds 1 V. Then allow V_D to reach 90% of its max value before toggling the ON pin from Low-to-High. Likewise, power-down in reverse order.

If V_{DD} and V_D need to be powered up simultaneously, glitching can be minimized by having a suitable load capacitor. A 10 μF C_{LOAD} will prevent glitches for rise times of V_{DD} and V_D higher than 2 ms.

If the ON pin is toggled HIGH before V_{DD} and V_D have reached their steady-state values, the load switch timing parameters may differ from datasheet specifications.

The slew rate of output V_S follows a linear ramp set by a capacitor connected to the CAP pin. A larger capacitor value at the CAP pin produces a slower ramp, reducing inrush current from capacitive loads.

SLG59M301V Current Limiting Operation

The SLG59M301V has two types of current limiting triggered by the output V_S pin voltage.

1. Standard Current Limiting Mode (with Thermal Shutdown Protection)

When the V_S pin voltage > 250 mV, the output current is initially limited to the Active Current Limit (I_{ACL}) specification listed in the Electrical Characteristics table. The ACL monitor's response time is very fast and is triggered within a few microseconds to sudden (transient) changes in load current. When a load current overload is detected, the ACL monitor increases the FET resistance to keep the current from exceeding the load switch's I_{ACL} threshold.

However, if a load-current overload condition persists where the die temperature rises because of the increased FET resistance, the load switch's internal Thermal Shutdown Protection circuit can be activated. If the die temperature exceeds the listed THERM_{ON} specification, the FET is shut OFF completely, thereby allowing the die to cool. When the die cools to the listed THERM_{OFF} temperature threshold, the FET is allowed to turn back on. This process may repeat as long as the output current overload condition persists.

2. Short Circuit Current Limiting Mode (with Thermal Shutdown Protection)

When the V_S pin voltage < 250 mV (which is the case with a hard short, such as a solder bridge on the power rail), the load switch's internal Short-circuit Current Limit (SCL) monitor limits the FET current to approximately 500 mA (the I_{SCL} threshold). While the internal Thermal Shutdown Protection circuit remains enabled and since the I_{SCL} threshold is much lower than the I_{ACL} threshold, thermal shutdown protection may become activated only at higher ambient temperatures.

SLG59M301V

An Ultra-small 3 mm², 8.5 mΩ, 4 A,
Internally-protected Load Switch

Power Dissipation

The junction temperature of the SLG59M301V depends on different factors such as board layout, ambient temperature, and other environmental factors. The primary contributor to the increase in the junction temperature of the SLG59M301V is the power dissipation of its power MOSFET. Its power dissipation and the junction temperature in nominal operating mode can be calculated using the following equations:

$$PD = RDS_{ON} \times I_{DS}^2$$

where:

PD = Power dissipation, in Watts (W)

RDS_{ON} = Power MOSFET ON resistance, in Ohms (Ω)

I_{DS} = Output current, in Amps (A)

and

$$T_J = PD \times \Theta_{JA} + T_A$$

where:

T_J = Junction temperature, in Celsius degrees (°C)

Θ_{JA} = Package thermal resistance, in Celsius degrees per Watt (°C/W)

T_A = Ambient temperature, in Celsius degrees (°C)

During active current-limit operation, the SLG59M301V's power dissipation can be calculated by taking into account the voltage drop across the load switch (V_D - V_S) and the magnitude of the output current in active current-limit operation (I_{ACL}):

$$PD = (V_D - V_S) \times I_{ACL} \text{ or}$$

$$PD = (V_D - (R_{LOAD} \times I_{ACL})) \times I_{ACL}$$

where:

PD = Power dissipation, in Watts (W)

V_D = Input Voltage, in Volts (V)

R_{LOAD} = Load Resistance, in Ohms (Ω)

I_{ACL} = Output limited current, in Amps (A)

V_S = R_{LOAD} × I_{ACL}

For more information on GreenFET load switch features, please visit our website and see App Note "AN-1068 GreenFET and High Voltage GreenFET Load Switch Basics".

SLG59M301V

An Ultra-small 3 mm², 8.5 mΩ, 4 A,
Internally-protected Load Switch

Layout Guidelines:

1. The VDD pin needs a 0.1 μF and 10 μF external capacitors to smooth pulses from the power supply. Locate this capacitor as close as possible to the SLG59M301V's PIN1.
2. Since the D/VIN and S/VOUT pins dissipate most of the heat generated during high-load current operation, it is highly recommended to make power traces as short, direct, and wide as possible. A good practice is to make power traces with an absolute minimum widths of 15 mils (0.381 mm) per Ampere. A representative layout, shown in Figure 1, illustrates proper techniques for heat to transfer as efficiently as possible out of the device;
3. To minimize the effects of parasitic trace inductance on normal operation, it is recommended to connect input C_{IN} and output C_{LOAD} low-ESR capacitors as close as possible to the SLG59M301V's D/VIN and S/VOUT pins;
4. The GND pin should be connected to system analog or power ground plane.

SLG59M301V Evaluation Board:

A GreenFET Evaluation Board for SLG59M301V is designed according to the statements above and is illustrated on Figure 1. Please note that evaluation board has D_Sense and S_Sense pads. They cannot carry high currents and dedicated only for RDS_{ON} evaluation.

Please solder your SLG59M301V here

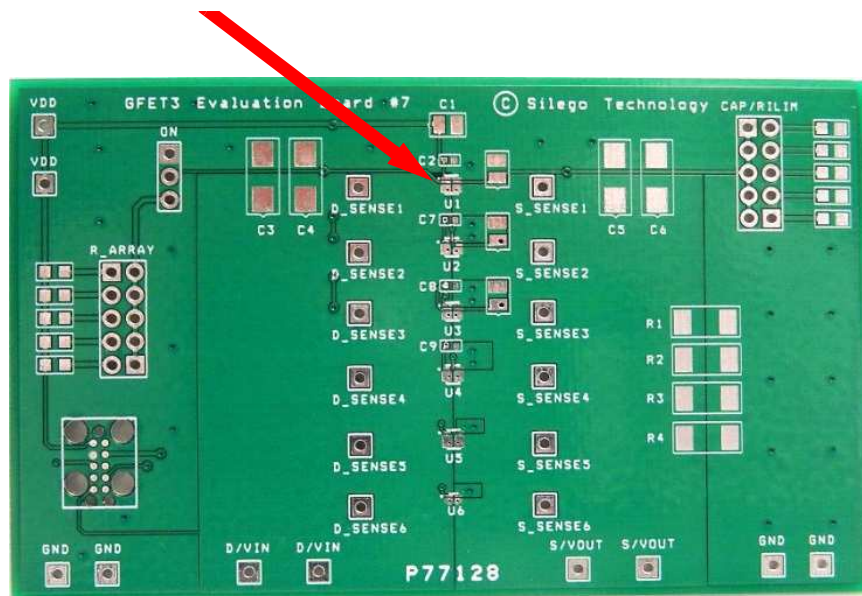

Figure 1. SLG59M301V Evaluation Board.

SLG59M301V

An Ultra-small 3 mm², 8.5 mΩ, 4 A,
Internally-protected Load Switch

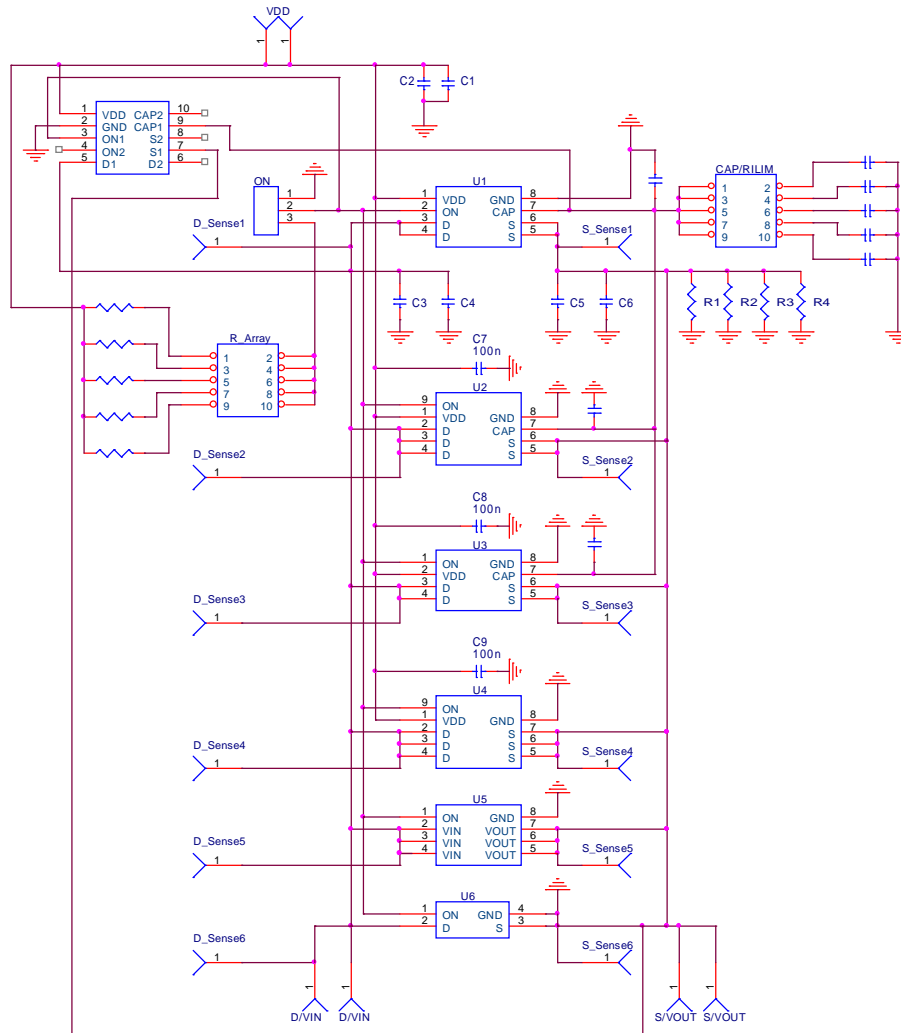

Figure 2. SLG59M301V Evaluation Board Connection Circuit.

SLG59M301V

An Ultra-small 3 mm², 8.5 mΩ, 4 A,
Internally-protected Load Switch

Basic Test Setup and Connections

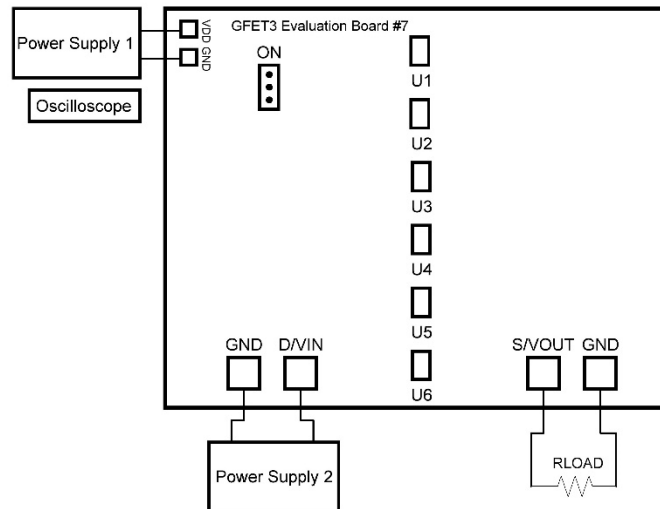

Figure 3. Typical connections for GreenFET Evaluation.

EV B Configuration

1. Connect oscilloscope probes to D/VIN, S/VOUT, ON, etc.;
2. Turn on Power Supply 1 and set desired V_{DD} from 2.5 V...5.5 V range;
3. Turn on Power Supply 2 and set desired V_D from 0.85 V...5.5 V range;
4. Toggle the ON signal High or Low to observe SLG59M301V operation.

SLG59M301V

An Ultra-small 3 mm², 8.5 mΩ, 4 A,
Internally-protected Load Switch

Package Top Marking System Definition

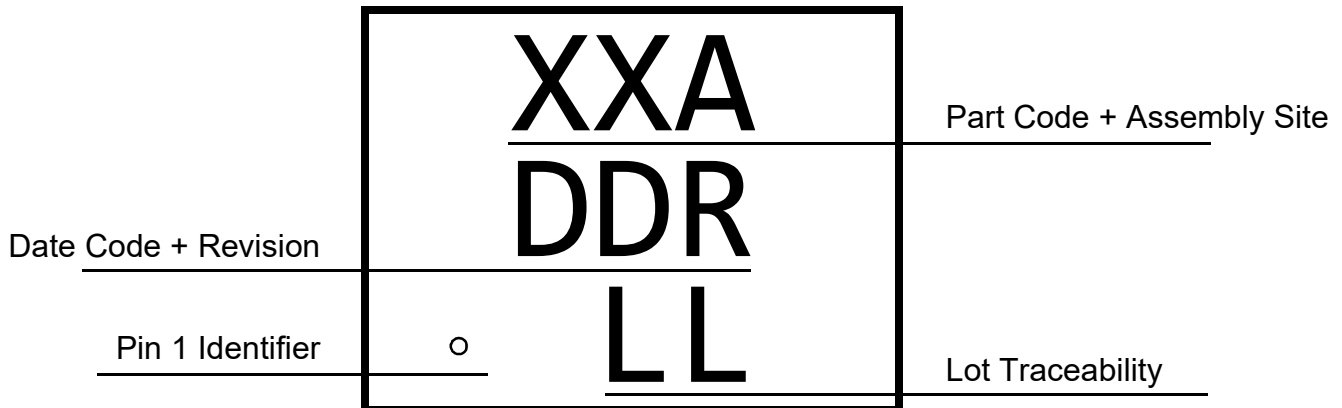

XX - Part Code Field¹
 A - Assembly Site Code Field²
 DD - Date Code Field¹
 R - Part Revision Code Field²
 LL - Lot Traceability Field¹

Note 1: Each character in code field can be alphanumeric A-Z and 0-9

Note 2: Character in code field can be alphabetic A-Z

SLG59M301V

An Ultra-small 3 mm², 8.5 mΩ, 4 A,
Internally-protected Load Switch

Package Drawing and Dimensions

8 Lead TDFN Package 1.5 x 2.0 mm (Fused Lead)
JEDEC MO-252

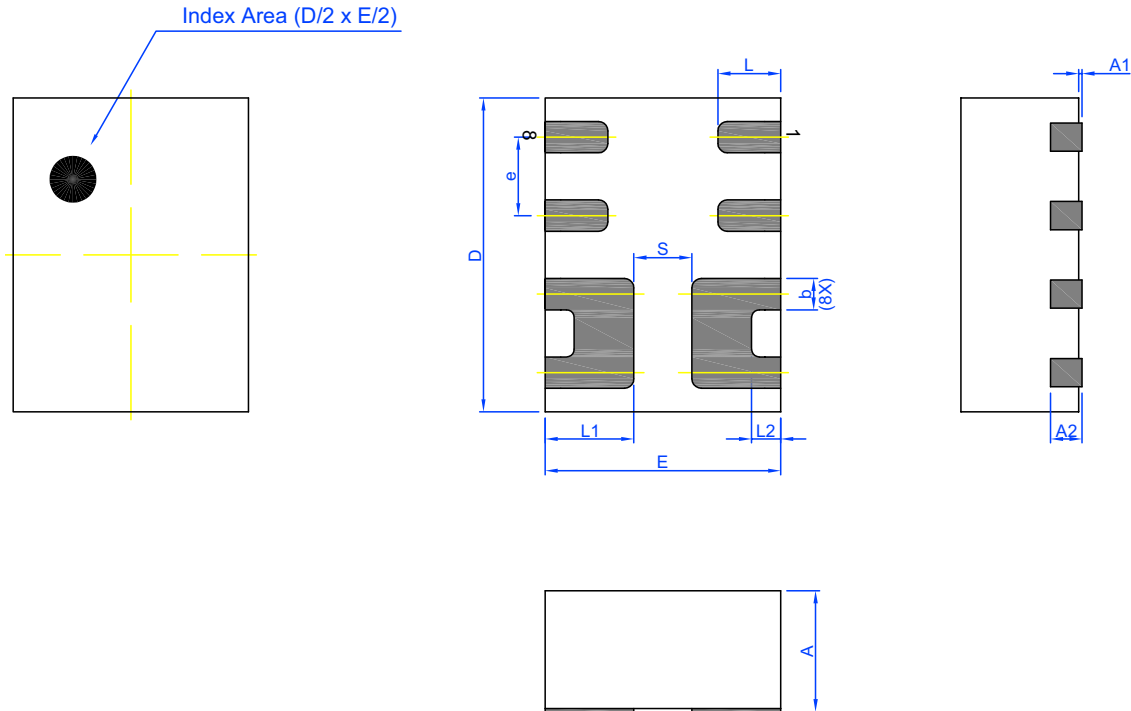

Unit: mm

Symbol	Min	Nom.	Max	Symbol	Min	Nom.	Max
A	0.70	0.75	0.80	L	0.35	0.40	0.45
A1	0.005	-	0.060	L1	0.515	0.565	0.615
A2	0.15	0.20	0.25	L2	0.135	0.185	0.235
b	0.15	0.20	0.25	e	0.50 BSC		
D	1.95	2.00	2.05	S	0.37 REF		
E	1.45	1.50	1.55				

SLG59M301V

An Ultra-small 3 mm², 8.5 mΩ, 4 A,
Internally-protected Load Switch

Tape and Reel Specifications

Package Type	# of Pins	Nominal Package Size [mm]	Max Units		Reel & Hub Size [mm]	Leader (min)		Trailer (min)		Tape Width [mm]	Part Pitch [mm]
			per Reel	per Box		Pockets	Length [mm]	Pockets	Length [mm]		
TDFN 8L FC Green	8	1.5 x 2.0 x 0.75	3000	3000	178 / 60	100	400	100	400	8	4

Carrier Tape Drawing and Dimensions

Package Type	Pocket BTM Length	Pocket BTM Width	Pocket Depth	Index Hole Pitch	Pocket Pitch	Index Hole Diameter	Index Hole to Tape Edge	Index Hole to Pocket Center	Tape Width
	A0	B0	K0	P0	P1	D0	E	F	W
TDFN 8L FC Green	1.68	2.18	0.9	4	4	1.5	1.75	3.5	8

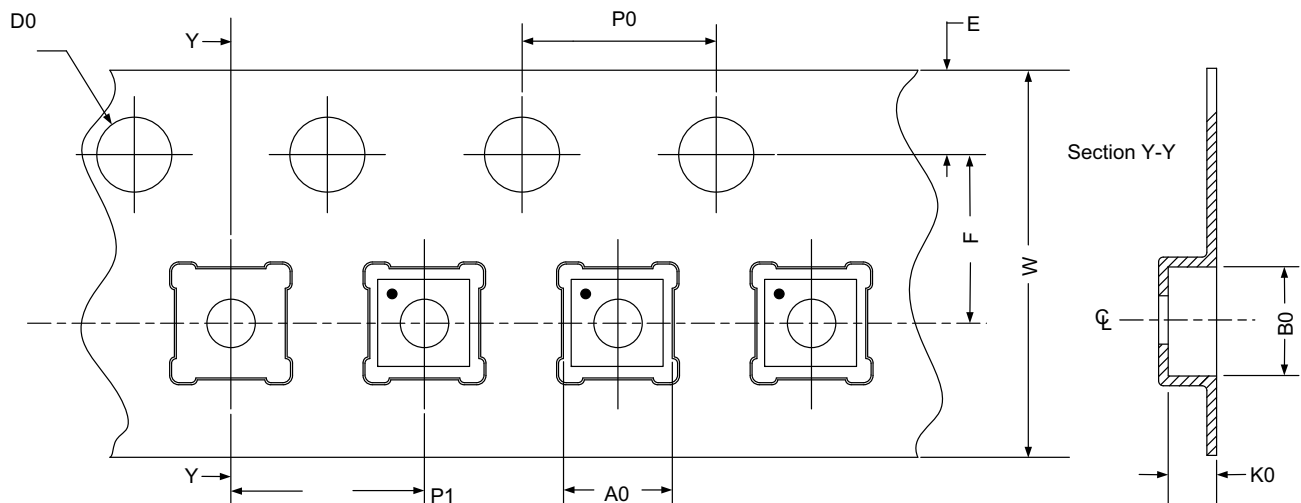

Refer to EIA-481 specification

Recommended Reflow Soldering Profile

Please see IPC/JEDEC J-STD-020: latest revision for reflow profile based on package volume of 2.25 mm³ (nominal). More information can be found at www.jedec.org.

SLG59M301V

An Ultra-small 3 mm², 8.5 mΩ, 4 A,
Internally-protected Load Switch

Revision History

Date	Version	Change
2/4/2022	1.16	Updated Company name and logo Fixed typos
11/5/2018	1.15	Updated Style and Formatting

IMPORTANT NOTICE AND DISCLAIMER

RENESAS ELECTRONICS CORPORATION AND ITS SUBSIDIARIES (“RENESAS”) PROVIDES TECHNICAL SPECIFICATIONS AND RELIABILITY DATA (INCLUDING DATASHEETS), DESIGN RESOURCES (INCLUDING REFERENCE DESIGNS), APPLICATION OR OTHER DESIGN ADVICE, WEB TOOLS, SAFETY INFORMATION, AND OTHER RESOURCES “AS IS” AND WITH ALL FAULTS, AND DISCLAIMS ALL WARRANTIES, EXPRESS OR IMPLIED, INCLUDING, WITHOUT LIMITATION, ANY IMPLIED WARRANTIES OF MERCHANTABILITY, FITNESS FOR A PARTICULAR PURPOSE, OR NON-INFRINGEMENT OF THIRD-PARTY INTELLECTUAL PROPERTY RIGHTS.

These resources are intended for developers who are designing with Renesas products. You are solely responsible for (1) selecting the appropriate products for your application, (2) designing, validating, and testing your application, and (3) ensuring your application meets applicable standards, and any other safety, security, or other requirements. These resources are subject to change without notice. Renesas grants you permission to use these resources only to develop an application that uses Renesas products. Other reproduction or use of these resources is strictly prohibited. No license is granted to any other Renesas intellectual property or to any third-party intellectual property. Renesas disclaims responsibility for, and you will fully indemnify Renesas and its representatives against, any claims, damages, costs, losses, or liabilities arising from your use of these resources. Renesas' products are provided only subject to Renesas' Terms and Conditions of Sale or other applicable terms agreed to in writing. No use of any Renesas resources expands or otherwise alters any applicable warranties or warranty disclaimers for these products.

(Disclaimer Rev.1.01 Jan 2024)

Corporate Headquarters

TOYOSU FORESIA, 3-2-24 Toyosu,
Koto-ku, Tokyo 135-0061, Japan
www.renesas.com

Trademarks

Renesas and the Renesas logo are trademarks of Renesas Electronics Corporation. All trademarks and registered trademarks are the property of their respective owners.

Contact Information

For further information on a product, technology, the most up-to-date version of a document, or your nearest sales office, please visit www.renesas.com/contact-us/.

Looking for pricing, stock, or lifecycle information?

Click below to explore more details on WIN SOURCE:

- ⊖ [View SLG59M301V on WIN SOURCE](#)
- ⊖ [Renesas Electronics America](#) Information

Optimize Your Supply Chain with WIN SOURCE Solutions

- ✓ Global Sourcing Solution
- ✓ Obsolete Management
- ✓ Cost Control Management
- ✓ Shortage Management
- ✓ Alternative Solution
- ✓ Excess Inventory Management