



**THE DATASHEET OF
VSC8486YJB-11**



VSC8486-11 Datasheet

10 Gbps XAUI to XFI LAN/WAN Transceiver



a  MICROCHIP company



Microsemi Headquarters

One Enterprise, Aliso Viejo,
CA 92656 USA

Within the USA: +1 (800) 713-4113

Outside the USA: +1 (949) 380-6100

Sales: +1 (949) 380-6136

Fax: +1 (949) 215-4996

Email: sales.support@microsemi.com

www.microsemi.com

©2018 Microsemi, a wholly owned subsidiary of Microchip Technology Inc. All rights reserved. Microsemi and the Microsemi logo are registered trademarks of Microsemi Corporation. All other trademarks and service marks are the property of their respective owners.

Microsemi makes no warranty, representation, or guarantee regarding the information contained herein or the suitability of its products and services for any particular purpose, nor does Microsemi assume any liability whatsoever arising out of the application or use of any product or circuit. The products sold hereunder and any other products sold by Microsemi have been subject to limited testing and should not be used in conjunction with mission-critical equipment or applications. Any performance specifications are believed to be reliable but are not verified, and Buyer must conduct and complete all performance and other testing of the products, alone and together with, or installed in, any end-products. Buyer shall not rely on any data and performance specifications or parameters provided by Microsemi. It is the Buyer's responsibility to independently determine suitability of any products and to test and verify the same. The information provided by Microsemi hereunder is provided "as is, where is" and with all faults, and the entire risk associated with such information is entirely with the Buyer. Microsemi does not grant, explicitly or implicitly, to any party any patent rights, licenses, or any other IP rights, whether with regard to such information itself or anything described by such information. Information provided in this document is proprietary to Microsemi, and Microsemi reserves the right to make any changes to the information in this document or to any products and services at any time without notice.

About Microsemi

Microsemi, a wholly owned subsidiary of Microchip Technology Inc. (Nasdaq: MCHP), offers a comprehensive portfolio of semiconductor and system solutions for aerospace & defense, communications, data center and industrial markets. Products include high-performance and radiation-hardened analog mixed-signal integrated circuits, FPGAs, SoCs and ASICs; power management products; timing and synchronization devices and precise time solutions, setting the world's standard for time; voice processing devices; RF solutions; discrete components; enterprise storage and communication solutions, security technologies and scalable anti-tamper products; Ethernet solutions; Power-over-Ethernet ICs and midspans; as well as custom design capabilities and services. Learn more at www.microsemi.com.

Contents

1	Revision History	1
1.1	Revision 4.4	1
1.2	Revision 4.3	1
1.3	Revision 4.2	1
1.4	Revision 4.1	1
1.5	Revision 4.0	1
1.6	Revision 2.0	1
2	Product Overview	2
2.1	Features	2
2.1.1	Low Power	2
2.1.2	Wide Range of Support	2
2.1.3	Tools for Rapid Design	2
2.1.4	Flexibility	3
3	Functional Descriptions	4
3.1	Operating Modes	4
3.1.1	XAUI to XFI Mode	5
3.2	Loopback	7
3.2.1	Loopback Modes	9
3.3	Loopback Paths	10
3.3.1	Loopback A	10
3.3.2	Loopback B	11
3.3.3	Loopback C	11
3.3.4	Loopback D	12
3.3.5	Loopback E	12
3.3.6	Loopback F	13
3.3.7	Loopback G	13
3.3.8	Loopback H	13
3.3.9	Loopback J	14
3.3.10	Loopback K	14
3.3.11	PMA Split Loopbacks J and K	15
3.4	Physical Media Attachment	15
3.4.1	Multiplexer Operation	16
3.4.2	Timing Operation	16
3.4.3	Reference Clock Rate Selection	17
3.4.4	WAN Mode	17
3.4.5	Clock Multiplier Unit Reference Clocking	17
3.4.6	Reference Clock Inputs	18
3.4.7	External Capacitors	21
3.4.8	XFI Transmit Data CML Output	21
3.4.9	XFI Transmitter Pre-Emphasis and Slew Rate	22
3.4.10	Line Rate Divided Clock Outputs	23
3.4.11	External Phase Lock Loop	24
3.4.12	High-Speed Serial Data Inputs	24
3.4.13	XFI Data Input Receiver Equalization	25
3.4.14	Loss of Signal	26
3.4.15	Loss of Optical Carrier	27
3.5	WAN Interface Sublayer	27
3.5.1	Operation	28
3.5.2	Section Overhead	30

3.5.3	Line Overhead	35
3.5.4	Pointer	40
3.5.5	Path Overhead	43
3.5.6	Reading Statistical Counters	47
3.5.7	Defects and Anomalies	48
3.5.8	Interrupt and Interrupt Masking	50
3.5.9	Overhead Serial Interfaces	50
3.5.10	Pattern Generator and Checker	54
3.5.11	Protocol Implementation Conformance Statement	54
3.6	Physical Coding Sublayer	54
3.6.1	Control Codes	55
3.6.2	Transmit Path	56
3.6.3	Receive Path	56
3.6.4	PCS Test Modes	57
3.7	Extended Physical Coding Sublayer	58
3.7.1	Autonegotiation	58
3.7.2	Frame Format	59
3.7.3	Link State Machines	59
3.7.4	FEC Controls and Feedback	60
3.7.5	Supervisory Channel	60
3.8	XGMII Extender Sublayer	61
3.8.1	XAUI Receiver	61
3.8.2	XAUI Loss of Signal	61
3.8.3	XAUI Receiver Equalization	62
3.8.4	XAUI Clock and Data Recovery	63
3.8.5	XAUI Code Group Synchronization	63
3.8.6	XAUI Lane Deskew	63
3.8.7	10b/8b Decoder	64
3.8.8	8b/10b Encoder and Serializer	64
3.8.9	XAUI Transmitter	64
3.8.10	XAUI Transmitter Pre-Emphasis	64
3.8.11	XAUI Transmitter Programmable-Output Swing	65
3.9	MDIO Serial Interface	66
3.9.1	MDIO Interface Operation	66
3.10	Two-Wire Serial Interface	68
3.10.1	Two-Wire Serial Controller	69
3.10.2	Automatic Mode	71
3.11	XFP or SFP+ Module Interface	72
3.11.1	General Purpose and LED Driver Outputs	74
3.12	JTAG Access Port	75
3.12.1	Instruction Register	79
3.12.2	Device ID Register	81
3.12.3	Bypass Register	81
3.12.4	Boundary Scan Register	81
3.13	Synchronous Ethernet	83
3.13.1	About Conventional Mode	83
3.13.2	Using Conventional Mode	84
3.13.3	About Enhanced Mode	85
3.13.4	Using Enhanced Mode	87
4	Registers	89
4.1	Device 1: PMA Registers	89
4.2	Device 2: WIS Registers	107
4.3	Device 3: PCS Registers	144
4.4	Device 4: PHY-XS Registers	157
4.5	Device 30: NVR and DOM Registers	170

5	Electrical Specifications	179
5.1	DC Characteristics	179
5.1.1	LVTTL Inputs and Outputs	179
5.1.2	Reference Clock	180
5.1.3	MDIO Interface	180
5.2	AC Characteristics	180
5.2.1	10-Gigabit Inputs and Outputs	181
5.2.2	XAUI Inputs and Outputs	186
5.2.3	Timing and Reference Clock	189
5.3	Operating Conditions	190
5.4	Stress Ratings	190
6	Pin Descriptions	192
6.1	Pin Diagram	192
6.2	Pins by Function	192
6.2.1	XFI 10-Gigabit Data Bus Interface	193
6.2.2	XAUI 10-Gigabit Data Bus Interface	193
6.2.3	Serial Bus Interface	194
6.2.4	Input and Output Reference Clocks	194
6.2.5	Status and Control	195
6.2.6	Phase-Locked Loop Filter Capacitors	196
6.2.7	JTAG Interface	197
6.2.8	Power and Ground	197
6.2.9	Miscellaneous Pins	198
7	Package Information	199
7.1	Package Drawing	199
7.2	Thermal Specifications	201
7.3	Moisture Sensitivity	201
8	Design Guidelines	202
8.1	Power Supply Connection	202
9	Ordering Information	204

Figures

Figure 1	Functional Block Diagram	5
Figure 2	Functions in XAUI to XFI Mode	6
Figure 3	Loopback Configuration	8
Figure 4	PHY XS Deep Network Loopback	11
Figure 5	PHY XS Shallow System Loopback	11
Figure 6	PHY XS Deep System Loopback	12
Figure 7	PHY XS Shallow Network Loopback	12
Figure 8	PCS FIFO System Loopback	12
Figure 9	Gearbox Network Loopback	13
Figure 10	PCS System Loopback	13
Figure 11	PCS System Loopback	14
Figure 12	PMA/WIS System Loopback	14
Figure 13	PMA Network Loopback	15
Figure 14	PMA Split Loopback (SPLITLOOPN = 0)	15
Figure 15	PMA Block Diagram	16
Figure 16	Reference Clock Input Receiver	21
Figure 17	CML XFI Output Driver	21
Figure 18	XFI Data Transmitter Differential Voltage with Pre-Emphasis	22
Figure 19	Fully SONET Jitter Compliant Reference Clock Configuration	24
Figure 20	CML XFI Data Receiver	25
Figure 21	PMA LOS Functional Block Diagram	26
Figure 22	WIS Transmit and Receive Functions	28
Figure 23	WIS Frame Structure	29
Figure 24	STS-192c/STM-64 Section and Line Overhead Structure	29
Figure 25	Path Overhead Octets	30
Figure 26	Primary Synchronization State Diagram	31
Figure 27	Secondary Synchronization (Interval Pattern Search) State Diagram	32
Figure 28	16-bit Designations within Payload Pointer	40
Figure 29	Pointer Interpreter State Diagram	42
Figure 30	Path Status (G1) Byte for ERDI_RDIN = 0	45
Figure 31	Path Status (G1) Byte for ERDI_RDIN = 1	45
Figure 32	TOSI Timing Diagram	51
Figure 33	ROSI Timing Diagram	54
Figure 34	PCS Block Diagram	55
Figure 35	64b/66b Block Formats	57
Figure 36	E-PCS Frame Format	59
Figure 37	E-PCS Framing State Diagram	60
Figure 38	XAUI Input Simplified Schematic (XAUI_RCVR)	61
Figure 39	Loss of Synchronization (Lane Sync) State Diagram	63
Figure 40	Loss of Alignment (LOA) State Diagram	64
Figure 41	XAUI Output Differential Voltage with Pre-Emphasis	65
Figure 42	MDIO Frame Format	67
Figure 43	Timing when MDIO is Sourced by STA	68
Figure 44	Timing when MDIO is Sourced by MMD	68
Figure 45	Serial Management Interface	69
Figure 46	Two-Wire Serial Access State Diagram	71
Figure 47	VSC8486-11 to XFP Host Recommended Interface Connections	72
Figure 48	VSC8486-11 to SFP+ Host Recommended Interface Connections	73
Figure 49	Interrupt/Status/Activity LED Connections	74
Figure 50	JTAG TAP Boundary Scan Test Architecture	77
Figure 51	TAP Controller State Diagram	78
Figure 52	Clock Path Distribution (Conventional Mode)	84
Figure 53	Synchronous Ethernet Block Diagram	87
Figure 54	Enhanced Mode Distribution of Clock Paths	88

Figure 55	10-Gigabit Data Input Compliance Mask	181
Figure 56	Datacom Sinusoidal Jitter Tolerance	182
Figure 57	10-Gigabit Data Output Compliance Mask	186
Figure 58	XAUI Receiver Input Sinusoidal Jitter Tolerance	187
Figure 59	XAUI Output Compliance Mask	189
Figure 60	Parametric Measurement Setup	189
Figure 61	Timing with MDIO Sourced by STA	189
Figure 62	Timing with MDIO Sourced by MMD	190
Figure 63	Pin Diagram	192
Figure 64	Package Drawing	200
Figure 65	Recommended Power Supply Isolation Schematic	203

Tables

Table 1	System Loopback Summary	9
Table 2	System Loopback and XFI Traffic	9
Table 3	Network Loopbacks Summary	10
Table 4	Split Loopbacks Summary	10
Table 5	Retiming Clock Sources for Network and Split Loopbacks	10
Table 6	REFSEL0_STATUS Logic	17
Table 7	WAN Mode Control Logic	17
Table 8	CMU and CRU Reference Clock Control and Frequency Summary	18
Table 9	Configuration for LAN/SAN Only	19
Table 10	Configuration With SONET/SDH Jitter Generation Compliance	19
Table 11	Configuration Without SONET/SDH Jitter Generation Compliance	20
Table 12	Configuration With Full SONET/SDH Jitter Compliance	20
Table 13	XFI Transmitter Pre-Emphasis Ratio	22
Table 14	CLK64AP/N Clock Output	23
Table 15	CLK64BP/N Clock Output	24
Table 16	Register 1x8002.14:11 RXINP/N Equalization Control	26
Table 17	PMA LOS Register Status and Control Summary	27
Table 18	Section Overhead	30
Table 19	Framing Parameter Description and Values	32
Table 20	Line Overhead Octets	36
Table 21	K2 Encodings	38
Table 22	H1/H2 Pointer Types	41
Table 23	Concatenation Indication Types	41
Table 24	Pointer Interpreter State Diagram Transitions	42
Table 25	STS Path Overhead Octets	43
Table 26	RDI-P and ERDI-P Bit Settings and Interpretation	46
Table 27	PMTICK Counters	48
Table 28	Defects and Anomalies	48
Table 29	TOSI/ROSI Addresses	51
Table 30	Control Codes	55
Table 31	E-PCS Logic	59
Table 32	XAUI Lane LOS Threshold Summary	62
Table 33	XAUI Receiver Lane Equalization Setting	62
Table 34	XAUI Transmitter Lane Pre-Emphasis Setting	65
Table 35	MDIO-Manageable Device Addresses	66
Table 36	Management Frame Format for Indirect Register Access	66
Table 37	XFP or SFP+ Host Application Pin Connections Summary	73
Table 38	GPO Configuration Control Summary	75
Table 39	JTAG TTL Signals	76
Table 40	TAP Controller States	78
Table 41	Supported Boundary Scan Test Instructions	80
Table 42	Boundary Scan Test Instruction Descriptions	80
Table 43	Device Identification Information	81
Table 44	Boundary Scan Register Bits	81
Table 45	Synchronous Ethernet Reference Clock Source	85
Table 46	Synchronous Ethernet Register Bits	86
Table 47	PMA_CTRL1: PMA Control 1 (1x0000)	89
Table 48	PMA_STAT1: PMA Status 1 (1x0001)	90
Table 49	PMA_DEVID1: PMA Device Identifier 1 (1x0002)	90
Table 50	PMA_DEVID2: PMA Device Identifier 2 (1x0003)	91
Table 51	PMA_SPEED: PMA Speed Capability (1x0004)	91
Table 52	PMA_DEVPKG1: PMA Devices in Package 1 (1x0005)	91
Table 53	PMA_DEVPKG2: PMA Devices in Package 2 (1x0006)	92
Table 54	PMA_CTRL2: PMA Control 2 (1x0007)	92

Table 55	PMA_STAT2: PMA Status 2 (1×0008)	92
Table 56	PMA_CTRL3: PMA Control 3 (1×0009)	94
Table 57	PMA_STAT3: PMA Status 3 (1×000A)	94
Table 58	Factory Test Register (1×000B–000D)	94
Table 59	PMA_PKGID1: PMA Package Identifier 1 (1×000E)	94
Table 60	PMA_PKGID2: PMA Package Identifier 2 (1×000F)	94
Table 61	PMA_CFG1: PMA Configuration 1 (1×8000)	95
Table 62	Factory Test Register (1×8001)	96
Table 63	PMA_RXEQ_CTRL: PMA Rx Equalization Control (1×8002)	96
Table 64	PMA_STAT4: PMA Status 4 (1×E600)	96
Table 65	PMA_CTRL4: PMA Control 4 (1×E601)	96
Table 66	PMA_CTRL5: PMA Control 5 (1×E602)	97
Table 67	High-Speed Data Output (Signal Quality Control) (1×E603)	98
Table 68	Synchronous Ethernet Clock Control (1×E604)	98
Table 69	DEV_CTRL3: DEVICE Control 3 (1×E605)	99
Table 70	DEV_STAT1: DEVICE Status 1 (1×E606)	100
Table 71	DEV_STAT2: DEVICE Status 2 (1×E607)	101
Table 72	PMA_LOS_ASSERT: PMA Loss of Signal Assert Control (1×E700)	102
Table 73	PMA_LOS_DEASSERT: PMA Loss of Signal Deassert Control (1×E701)	102
Table 74	PMA_LOS_STAT: PMA Loss of Signal Status (1×E702)	103
Table 75	DEV_ID: DEVICE Identifier (1×E800)	103
Table 76	DEV_REV: DEVICE Revision (1×E801)	103
Table 77	Factory Test Register (1×E900)	103
Table 78	DEV_GPIO_CTRL: DEVICE General Purpose I/O Control (1×E901)	103
Table 79	DEV_XFP_CTRL: DEVICE XFP Control (1×E902)	104
Table 80	Factory Test Register (1×EC00)	105
Table 81	Factory Test (1×EC01–EC34)	105
Table 82	Factory Test (1×ED00–ED0F)	105
Table 83	Factory Test Register (1×EF00)	105
Table 84	DEV_RST_CTRL: DEVICE Block Reset Control (1×EF01)	105
Table 85	DEV_XFI_CTRL2: DEVICE XFI Loopback Control 2 (1×EF10)	106
Table 86	WIS_CTRL1: WIS Control 1 (2×0000)	107
Table 87	WIS_STAT1: WIS Status 1 (2×0001)	107
Table 88	WIS_DEVID1: WIS Device Identifier 1 (2×0002)	108
Table 89	WIS_DEVID2: WIS Device Identifier 2 (2×0003)	108
Table 90	WIS_SPEED: WIS Speed Capability (2×0004)	108
Table 91	WIS_DEVPKG1: WIS Devices in Package 1 (2×0005)	108
Table 92	WIS_DEVPKG2: WIS Devices in Package 2 (2×0006)	109
Table 93	WIS_CTRL2: WIS Control 2 (2×0007)	109
Table 94	WIS_STAT2: WIS Status 2 (2×0008)	110
Table 95	WIS_TSTPAT_CNT: WIS Test Pattern Error Counter (2×0009)	110
Table 96	WIS_PKGID1: WIS Package Identifier 1 (2×000E)	111
Table 97	WIS_PKGID2: WIS Package Identifier 2 (2×000F)	111
Table 98	WIS_STAT3: WIS Status 3 (2×0021)	111
Table 99	WIS_REI_CNT: WIS Far-End Path Block Error Count (2×0025)	112
Table 100	WIS_TXJ1: WIS Tx J1s (2×0027–002E)	112
Table 101	WIS_RXJ1: WIS Rx J1s (2×002F–0036)	112
Table 102	WIS_REIL_CNT1: WIS Far-End Line BIP Errors 1 (2×0037)	113
Table 103	WIS_REIL_CNT0: WIS Far-End Line BIP Errors 0 (2×0038)	113
Table 104	WIS_B2_CNT1: WIS L-BIP Error Count 1 (2×0039)	113
Table 105	WIS_B2_CNT0: WIS L-BIP Error Count 0 (2×003A)	113
Table 106	WIS_B3_CNT: WIS P-BIP Block Error Count (2×003B)	113
Table 107	WIS_B1_CNT: WIS S-BIP Error Count (2×003C)	113
Table 108	WIS_TXJ0: WIS Transmit J0s (2×0040–0047)	114
Table 109	WIS_RXJ0: WIS Rx J0s (2×0048–004F)	114
Table 110	EWIS_TXCTRL1: WIS Vendor-Specific Tx Control 1 (2×E600)	114
Table 111	Factory Test Register (2×E601)	115
Table 112	Factory Test Register (2×E602)	116
Table 113	Factory Test Register (2×E603)	116

Table 114	Factory Test Register (2×E604)	116
Table 115	Factory Test Register (2×E605)	116
Table 116	EWIS_TX_A1_A2: E-WIS Tx A1/A2 Octets (2×E611)	116
Table 117	EWIS_TX_Z0_E1: E-WIS Tx Z0/E1 Octets (2×E612)	116
Table 118	EWIS_TX_F1_D1: E-WIS Tx F1/D1 Octets (2×E613)	117
Table 119	EWIS_TX_D2_D3: E-WIS Tx D2/D3 Octets (2×E614)	117
Table 120	EWIS_TX_C2_H1: E-WIS Tx C2/H1 Octets (2×E615)	117
Table 121	EWIS_TX_H2_H3: E-WIS Tx H2/H3 Octets (2×E616)	117
Table 122	EWIS_TX_G1_K1: E-WIS Tx G1/K1 Octets (2×E617)	117
Table 123	EWIS_TX_K2_F2: E-WIS Tx K2/F2 Octets (2×E618)	117
Table 124	EWIS_TX_D4_D5: E-WIS Tx D4/D5 Octets (2×E619)	118
Table 125	EWIS_TX_D6_H4: E-WIS Tx D6/H4 Octets (2×E61A)	118
Table 126	EWIS_TX_D7_D8: E-WIS Tx D7/D8 Octets (2×E61B)	118
Table 127	EWIS_TX_D9_Z3: E-WIS Tx D9/Z3 Octets (2×E61C)	118
Table 128	EWIS_TX_D10_D11: E-WIS Tx D10/D11 Octets (2×E61D)	118
Table 129	EWIS_TX_D12_Z4: E-WIS Tx D12/Z4 Octets (2×E61E)	119
Table 130	EWIS_TX_S1_Z1: E-WIS Tx S1/Z1 Octets (2×E61F)	119
Table 131	EWIS_TX_Z2_E2: E-WIS Tx Z2/E2 Octets (2×E620)	119
Table 132	EWIS_TX_N1: E-WIS Tx N1 Octet (2×E621)	119
Table 133	Factory Test Register (2×E622)	119
Table 134	EWIS_TX_MSGLN: E-WIS Tx Trace Message Length Control (2×E700)	119
Table 135	EWIS_TXJ0: E-WIS Tx J0s 16–63 (2×E800–E817)	120
Table 136	EWIS_RXJ0: E-WIS Rx J0s 16–63 (2×E900–E917)	120
Table 137	EWIS_TXJ1: E-WIS Tx J1s 16–63 (2×EA00–EA17)	120
Table 138	EWIS_RXJ1: E-WIS Rx J1s 16–63 (2×EB00–EB17)	121
Table 139	EWIS_RX_FRM_CTRL1: E-WIS Rx Framer Control 1 (2×EC00)	121
Table 140	EWIS_RX_FRM_CTRL2: E-WIS Rx Framer Control 2 (2×EC01)	121
Table 141	EWIS_LOF_CTRL1: E-WIS Loss of Frame Control 1 (2×EC02)	122
Table 142	EWIS_LOF_CTRL2: E-WIS Loss of Frame Control 2 (2×EC03)	122
Table 143	EWIS_RX_CTRL1: E-WIS Rx Control 1 (2×EC10)	123
Table 144	EWIS_RX_MSGLN: E-WIS Rx Trace Message Length Control (2×EC20)	123
Table 145	EWIS_RX_ERR_FRC1: E-WIS Rx Error Force Control 1 (2×EC30)	124
Table 146	EWIS_RX_ERR_FRC2: E-WIS Rx Error Force Control 2 (2×EC31)	125
Table 147	EWIS_MODE_CTRL: E-WIS Mode Control (2×EC40)	126
Table 148	Factory Test Register (2×EC41)	127
Table 149	EWIS_PRBS31_ANA_CTRL: E-WIS PRBS31 Analyzer Control (2×EC50)	127
Table 150	EWIS_PRBS31_ANA_STAT: E-WIS PRBS31 Analyzer Status (2×EC51)	127
Table 151	EWIS_PMTICK_CTRL: E-WIS Performance Monitor Control (2×EC60)	128
Table 152	EWIS_CNT_CFG: E-WIS Counter Configuration (2×EC61)	129
Table 153	EWIS_CNT_STAT: E-WIS Counter Status (2×EC62)	129
Table 154	EWIS_REIP_CNT1: E-WIS P-REI Counter 1 (MSW) (2×EC80)	130
Table 155	EWIS_REIP_CNT0: E-WIS P-REI Counter 0 (LSW) (2×EC81)	130
Table 156	EWIS_REIL_CNT1: E-WIS L-REI Counter 1 (MSW) (2×EC90)	130
Table 157	EWIS_REIL_CNT0: E-WIS L-REI Counter 0 (LSW) (2×EC91)	130
Table 158	Factory Test Register (2×ECA0)	131
Table 159	EWIS_B1_ERR_CNT1: E-WIS S-BIP Error Counter 1 (MSW) (2×ECB0)	131
Table 160	EWIS_B1_ERR_CNT0: E-WIS S-BIP Error Counter 0 (LSW) (2×ECB1)	131
Table 161	EWIS_B2_ERR_CNT1: E-WIS L-BIP Error Counter 1 (MSW) (2×ECB2)	131
Table 162	EWIS_B2_ERR_CNT0: E-WIS L-BIP Error Counter 0 (LSW) (2×ECB3)	131
Table 163	EWIS_B3_ERR_CNT1: E-WIS P-BIP Error Counter 1 (MSW) (2×ECB4)	132
Table 164	EWIS_B3_ERR_CNT0: E-WIS P-BIP Error Counter 0 (LSW) (2×ECB5)	132
Table 165	Factory Test Register (2×ED00–ED08)	132
Table 166	EWIS_RXTX_CTRL: E-WIS Rx to Tx Control (2×EE00)	132
Table 167	EWIS_PEND1: E-WIS Interrupt Pending 1 (2×EF00)	133
Table 168	EWIS_MASKA_1: E-WIS Interrupt Mask A 1 (2×EF01)	135
Table 169	EWIS_MASKB_1: E-WIS Interrupt Mask B 1 (2×EF02)	136
Table 170	EWIS_INTR_STAT2: E-WIS Interrupt Status 2 (2×EF03)	138
Table 171	EWIS_INTR_PEND2: E-WIS Interrupt Pending 2 (2×EF04)	139
Table 172	EWIS_INTR_MASKA2: E-WIS Interrupt Mask A 2 (2×EF05)	141

Table 173	EWIS_INTR_MASKB2: E-WIS Interrupt Mask B 2 (2×EF06)	142
Table 174	WIS Fault Control (2×EF07)	143
Table 175	PCS_CTRL1: PCS Control 1 (3×0000)	144
Table 176	PCS_STAT1: PCS Status 1 (3×0001)	145
Table 177	PCS_DEVID1: PCS Device Identifier 1 (3×0002)	145
Table 178	PCS_DEVID2: PCS Device Identifier 2 (3×0003)	145
Table 179	PCS_SPEED: PCS Speed Capability (3×0004)	145
Table 180	PCS_DEVPKG1: PCS Devices in Package 1 (3×0005)	146
Table 181	PCS_DEVPKG2: PCS Devices in Package 2 (3×0006)	146
Table 182	PCS_CTRL2: PCS Control 2 (3×0007)	146
Table 183	PCS_STAT2: PCS Status 2 (3×0008)	147
Table 184	PCS_PKGID1: PCS Package Identifier 1 (3×000E)	147
Table 185	PCS_PKGID2: PCS Package Identifier 2 (3×000F)	148
Table 186	PCS_10GBASEX_STAT: PCS 10G BASE-X Status (3×0018)	148
Table 187	PCS_10GBASEX_CTRL: PCS 10G BASE-X Control (3×0019)	148
Table 188	PCS_10GBASER_STAT1: PCS 10G BASE-R Status 1 (3×0020)	148
Table 189	PCS_10GBASER_STAT2: PCS 10G BASE-R Status 2 (3×0021)	149
Table 190	PCS_SEEDA3: PCS Test Pattern Seed A 3 (3×0022)	149
Table 191	PCS_SEEDA2: PCS Test Pattern Seed A 2 (3×0023)	149
Table 192	PCS_SEEDA1: PCS Test Pattern Seed A 1 (3×0024)	149
Table 193	PCS_SEEDA0: PCS Test Pattern Seed A 0 (3×0025)	149
Table 194	PCS_SEEDB3: PCS Test Pattern Seed B 3 (3×0026)	150
Table 195	PCS_SEEDB2: PCS Test Pattern Seed B 2 (3×0027)	150
Table 196	PCS_SEEDB1: PCS Test Pattern Seed B 1 (3×0028)	150
Table 197	PCS_SEEDB0: PCS Test Pattern Seed B 0 (3×0029)	150
Table 198	PCS_TSTPAT_CTRL: PCS Test Pattern Control (3×002A)	150
Table 199	PCS_TSTPAT_CNT: PCS Test Pattern Error Counter (3×002B)	151
Table 200	PCS_USRPAT0: PCS User Test Pattern 0 (3×8000)	151
Table 201	PCS_USRPAT1: PCS User Test Pattern 1 (3×8001)	151
Table 202	PCS_USRPAT2: PCS User Test Pattern 2 (3×8002)	151
Table 203	PCS_USRPAT3: PCS User Test Pattern 3 (3×8003)	152
Table 204	PCS_SQPW_CTRL: PCS Square Wave Pulse Width Control (3×8004)	152
Table 205	PCS_CFG1: PCS Configuration 1 (3×8005)	152
Table 206	PCS_ERR_CNT0: PCS Test Error Counter 0 (3×8007)	153
Table 207	PCS_ERR_CNT1: PCS Test Error Counter 1 (3×8008)	153
Table 208	Factory Test Register (3×8009)	153
Table 209	Factory Test Register (3×800C)	153
Table 210	Factory Test Register (3×800D)	153
Table 211	Factory Test Register (3×800E)	153
Table 212	Factory Test Register (3×800F)	153
Table 213	Factory Test Register (3×8010)	154
Table 214	Factory Test Register (3×8011)	154
Table 215	Factory Test Register (3×8012)	154
Table 216	Factory Test Register (3×8013)	154
Table 217	Factory Test Register (3×8014)	154
Table 218	Factory Test Register (3×8015)	154
Table 219	PCS_CFG2: PCS Configuration 2 (3×E600)	154
Table 220	Factory Test Register (3×E601)	155
Table 221	Factory Test Register (3×E602)	155
Table 222	Factory Test Register (3×E603)	155
Table 223	EPCS_STAT1: E-PCS Status 1 (3×E604)	155
Table 224	EPCS_CORR_CNT: E-PCS Corrected FEC Error Counter (3×E605)	156
Table 225	EPCS_UCORR_CNT: E-PCS UnCorrected FEC Error Counter (3×E606)	156
Table 226	EPCS_TXMSG: E-PCS Tx Message (3×E60A-E611)	156
Table 227	EPCS_RXMSG: E-PCS Rx Message (3×E612-E619)	156
Table 228	Factory Test Register (3×E61A)	156
Table 229	Factory Test Register (3×E61B)	157
Table 230	Factory Test Register (3×E61C)	157
Table 231	Factory Test Register (3×E61D)	157

Table 232	PHYXS_CTRL1: PHY XS Control 1 (4×0000)	157
Table 233	PHYXS_STAT1: PHY XS Status1 (4×0001)	158
Table 234	PHYXS_DEVID1: PHY XS Device Identifier 1 (4×0002)	158
Table 235	PHYXS_DEVID2: PHY XS Device Identifier 2 (4×0003)	158
Table 236	PHYXS_SPEED: PHY XS Speed Capability (4×0004)	159
Table 237	PHYXS_DEVPKG1: PHY XS Devices in Package 1 (4×0005)	159
Table 238	PHYXS_DEVPKG2: PHY XS Devices in Package 2 (4×0006)	159
Table 239	PHYXS_STAT2: PHY XS Status 2 (4×0008)	160
Table 240	PHYXS_STAT3: PHY XS Status 3 (4×0018)	160
Table 241	PHYXS_TSTCTRL1: PHY XGXS Test Control 1 (4×0019)	161
Table 242	PHYXS_TSTCTRL2: PHY XS Test Control 2 (4×8000)	161
Table 243	PHYXS_TSTSTAT: PHY XS Test Pattern Check Status (4×8001)	162
Table 244	Factory Test Register (4×8002)	162
Table 245	Factory Test Register (LSW) (4×8003)	162
Table 246	Factory Test Register (4×8004)	162
Table 247	Factory Test Register (4×8005)	162
Table 248	Factory Test Register (4×8006)	162
Table 249	Factory Test Register (4×8007)	163
Table 250	Factory Test Register (4×8008)	163
Table 251	Factory Test Register (4×8009)	163
Table 252	Factory Test Register (4×800A)	163
Table 253	PHYXS_TPERR_CTRL: PHY XS Test Pattern Error Counter Control (4×800B)	163
Table 254	PHYXS_TPERR_CNT0: PHY XS Test Pattern Error Counter 0 (LSW) (4×800C)	164
Table 255	PHYXS_TPERR_CNT0: PHY XS Test Pattern Error Counter 1 (MSW) (4×800D)	164
Table 256	PHYXS_XAUI_CTRL1: PHY XS XAUI Control 1 (4×800E)	164
Table 257	PHYXS_XAUI_CTRL2: PHY XS XAUI Control 2 (4×800F)	164
Table 258	PHYXS_RXEQ_CTRL: PHY XS XAUI Rx Equalization Control (4×8010)	165
Table 259	PHYXS_TXPE_CTRL: PHY XS XAUI Tx Pre-Emphasis Control (4×8011)	166
Table 260	PHYXS_RXLOS_STAT: PHY XS Rx Loss of Signal Status (4×8012)	166
Table 261	PHYXS_RXSD_STAT: PHY XS Rx Signal Detect Status (4×E600)	167
Table 262	Factory Test Register (4×E601)	167
Table 263	PHYXS_TXPD_CTRL: PHY XS XAUI Tx Power Down Control (4×E602)	167
Table 264	PHYXS_RXPD_CTRL: PHY XS XAUI Rx Power Down Control (4×E603)	168
Table 265	FC_CJPAT_SEL (4×E604)	169
Table 266	Factory Test Register (4×E610)	169
Table 267	STW_CTRL1: STW Control 1 (1E×8000)	170
Table 268	STW_DEVADDR: STW Device Address (1E×8002)	170
Table 269	STW_REGADDR: STW Register Address (1E×8003)	171
Table 270	STW_CFG1: STW Configuration 1 (1E×8004)	171
Table 271	NVR Memory Map (1E×8007–8106)	171
Table 272	DOM_RXALRM_CTRL: DOM Rx Alarm Control (1E×9000)	171
Table 273	DOM_TXALRM_CTRL: DOM Tx Alarm Control (1E×9001)	172
Table 274	DOM_LASI_CTRL: DOM Link Alarm Status Interrupt Control (1E×9002)	172
Table 275	DOM_RXALRM_STAT: DOM Rx Alarm Status (1E×9003)	172
Table 276	DOM_TXALRM_STAT: DOM Tx Alarm Status (1E×9004)	173
Table 277	DOM_LASI_STAT: DOM Link Alarm Status Interrupt Status (1E×9005)	173
Table 278	DOM_TXFLAG_CTRL: DOM Tx Flag Control (1E×9006)	174
Table 279	DOM_RXFLAG_CTRL: DOM Rx Flag Control (1E×9007)	174
Table 280	Factory Test Register (1E×A000-A027)	175
Table 281	Factory Test Register (1E×A048-A05F)	175
Table 282	Factory Test Register (1E×A060-A06D)	175
Table 283	Factory Test Register (1E×A06E)	175
Table 284	Factory Test Register (1E×A06F)	175
Table 285	DOM_TXALARM: DOM Tx Alarm Flags (1E×A070)	175
Table 286	DOM_RXALARM: DOM Rx Alarm Flags (1E×A071)	176
Table 287	Factory Test Register (1E×A072-A073)	176
Table 288	DOM_TXWARN: DOM Tx Warning Flags (1E×A074)	176
Table 289	DOM_RXWARN: DOM Rx Warning Flags (1E×A075)	177
Table 290	Factory Test Register (1E×A076-A077)	177

Table 291	Factory Test Register (1E×A0C0-A0FF)	177
Table 292	Factory Test Register (1E×A100)	177
Table 293	Factory Test Register (1E×A101-A106)	178
Table 294	LVTTL I/O Specifications	179
Table 295	Reference Clock Input Specifications	180
Table 296	MDIO Interface Characteristics	180
Table 297	10-Gigabit Serial Data Input Specifications	181
Table 298	10-Gigabit Serial Data Input Specifications for CRU	182
Table 299	10-Gigabit Serial Data Output Specifications	184
Table 300	10-Gigabit Serial Data Input/Output Specifications for CMU, WAN Mode	184
Table 301	10-Gigabit Serial Data Output Specifications for CMU, LAN/SAN Mode	184
Table 302	XAUI Input Specifications	186
Table 303	XAUI Output Specifications	187
Table 304	Reset Timing	189
Table 305	Reference Clock Specifications	189
Table 306	Recommended Operating Conditions	190
Table 307	Stress Ratings	190
Table 308	XFI 10-Gigabit Data Bus Pins	193
Table 309	XAUI 10-Gigabit Data Bus Pins	193
Table 310	Serial Bus Interface Pins	194
Table 311	Input and Output Reference Clock Pins	194
Table 312	Status and Control Pins	195
Table 313	Phase-Locked Loop Filter Capacitor Pins	196
Table 314	JTAG Interface Pins	197
Table 315	Power and Ground Pins	197
Table 316	Miscellaneous	198
Table 317	Thermal Resistances	201
Table 318	Power Supply and Pin Locations	202
Table 319	Ordering Information	204

1 Revision History

This section describes the changes that were implemented in this document. The changes are listed by revision, starting with the most current publication.

1.1 Revision 4.4

In revision 4.4 of this document, the XAUI LOS signal information was clarified. For more information, see [Table 259](#), page 166 (bits 3:2) and [Table 260](#), page 166 (bits 3:0).

1.2 Revision 4.3

In revision 4.3 of this document, the lead-free (Pb-free) package, VSC8486YJB-11, was added.

1.3 Revision 4.2

The following is a summary of the changes in revision 4.2 of this document.

- Two-wire serial to SFP+/XFP manual mode of operation is not supported. The STW_MODE register bit must be set to 0 for automatic mode of operation.
- Two-wire serial reset command register was clarified. It can only be used to reset the local two-wire serial circuit, not to reset downstream SFP+/XFP devices.

1.4 Revision 4.1

In revision 4.1 of this document, the minimum recommended operating temperature was changed from 0 °C ambient to –40 °C ambient, and the minimum reference clock frequency was changed from 156.25 MHz to 153 MHz.

1.5 Revision 4.0

The following is a summary of the changes in revision 4.0 of this document.

- The VSC8486-11 device is compliant with SFF-8431 (SFP+) revision 4.1.
- Electrical specifications were updated based on final characterization results.
- For applications that do not require high input gain, the synchronous Ethernet clock control register 1xE604.15 should be set to 1 for optimal jitter tolerance.
- The remote error indication (REI-P) status bit will be triggered in the event of an invalid REI-P value; however, the REI-P counter will not be incremented.
- Registers 1xE602.10, 2xEF00.14, 2xEF01.14, and 2xEF02.14 are now reserved.
- Extended WIS TOSI and ROSI do not support path overhead.

1.6 Revision 2.0

Revision 2.0 was the first publication of this document.

2 Product Overview

The VSC8486-11 is a LAN/WAN XAUI transceiver that converts 3 Gbps XAUI data to a 10 Gbps serial stream. At just 840 mW, the VSC8486-11 is ideal for applications requiring low power. The device is also equipped with an additional full-rate data port that can be utilized for bypass monitoring or channel monitoring applications. The device meets all specifications for 10 Gigabit Ethernet (GbE) Layer-1 processing, as defined in IEEE 802.3ae.

The VSC8486-11 offers exceptional 10 Gbps mixed-signal performance with a data output that features programmable pre-emphasis to enable longer traces of copper. The VSC8486-11 high-speed serial I/O supports 9.9 Gbps, 10.3 Gbps, and 10.5 Gbps, as defined by IEEE 802.3ae and T11 10 GFC, and is fully compliant with the SONET jitter specification defined by Bellcore GR253.

There are four main data processing blocks in the device: XGXS, PCS, WIS, and PMA. The 10 GbE extender sublayer (XGXS) accepts 8b/10b data running at 3.125 Gbps and decodes it for transmission to the physical coding sublayer (PCS). The XGXS is capable of deskewing more than 60 bit times between lanes. The PCS receives data from the XGXS at 10 Gbps and encodes data according to the 64b/66b algorithm described in IEEE 802.3ae clause 49.

The PCS features an optional extended mode (E-PCS) that also runs at the 64b/66b rate. This extended mode uses an alternative framing algorithm that adds forward error correction (FEC) to provide ~2.5 dB of net electrical coding gain. The E-PCS is available for LAN mode but not WAN mode.

The PCS outputs data to the WAN interface sublayer (WIS) when this mode is active (it is bypassed in LAN mode). The WIS optionally takes data from the PCS at 9.953 Gbps and frames data in a SONET STS-192c frame, as described in IEEE 802.3ae clause 50. Additionally, the WIS block contains extended SONET and SDH processing capabilities that allow system operators to leverage valuable performance monitoring data. Finally, data is delivered to the physical media attachment (PMA) block. The PMA multiplexes the internal parallel data bus into a 10 Gbps data stream.

The 10 Gbps to XAUI data channel performs the operations described above in reverse. Notable features in this path are a SONET-compliant LOS detector and a 10 Gbps receiver that is fully compliant with XFI specifications, including stressed eye criteria.

The device operates using a 1.2 V supply dissipating only 750 mW in LAN mode and 840 mW in WAN mode. The VSC8486-11 is available in lead-free (Pb-free) packages.

2.1 Features

The following list provides the features and benefits of the VSC8486-11 device.

2.1.1 Low Power

- Exceptionally low power (750 mW LAN mode or 840 mW WAN mode) allows for higher port densities

2.1.2 Wide Range of Support

- Fully compatible with IEEE 802.3ae and T11 10 GFC
- Extended-WIS (E-WIS) provides full Clause 50 support and enables transport over existing SONET networks
- 10 Gbps serial interface exceeds all SONET and 10 GbE requirements
- 4× 3.125 Gbps and 3.182 Gbps XAUI I/O enable interconnection with a wide range of Layer-2 devices
- Seamless connectivity to XFP and SFP+ modules

2.1.3 Tools for Rapid Design

- Multiple loopback modes and built-in self test (BIST) capabilities reduce system development costs, enable manufacturing tests, and improve time to market
- JTAG access port facilitates boundary scan for in-circuit test to improve board yield

- Single 1.2 voltage for the whole device with optional power supply range (1.2 V, 1.5 V, 1.8 V, or 3.3 V) for the TTL interface

2.1.4 Flexibility

- XAUI I/O programmability for lane swap, invert, amplitude, pre-emphasis, and equalization
- KX4-compatible 3 Gbps I/O for long-reach copper interconnect provides additional margin to traverse connectors and the backplane up to 40 inches
- Extended-PCS (E-PCS) mode with forward error correction (FEC) autonegotiation allows extended reach over single-mode and multimode fiber with 10^{-15} error floor
- On the 10-gigabit serial link, enhanced de-emphasis and equalization compensates for connector and channel losses and makes the device SFP+ compliant
- Accessibility of the recovered clock from high speed input and separate clock paths for CMU and CRU enable Layer 1 support for Synchronous Ethernet

3 Functional Descriptions

This section presents the functional description for the VSC8486-11 device. The main areas described are:

- Data paths
- Loopback options
- Implementation of the IEEE MDIO manageable devices (MMDs)
- Extended functionality for WIS and PCS
- Low-speed serial interfaces (MDIO, two-wire serial, and JTAG)

3.1 Operating Modes

The following illustration summarizes the VSC8486-11 operations.

Figure 1 • Functional Block Diagram

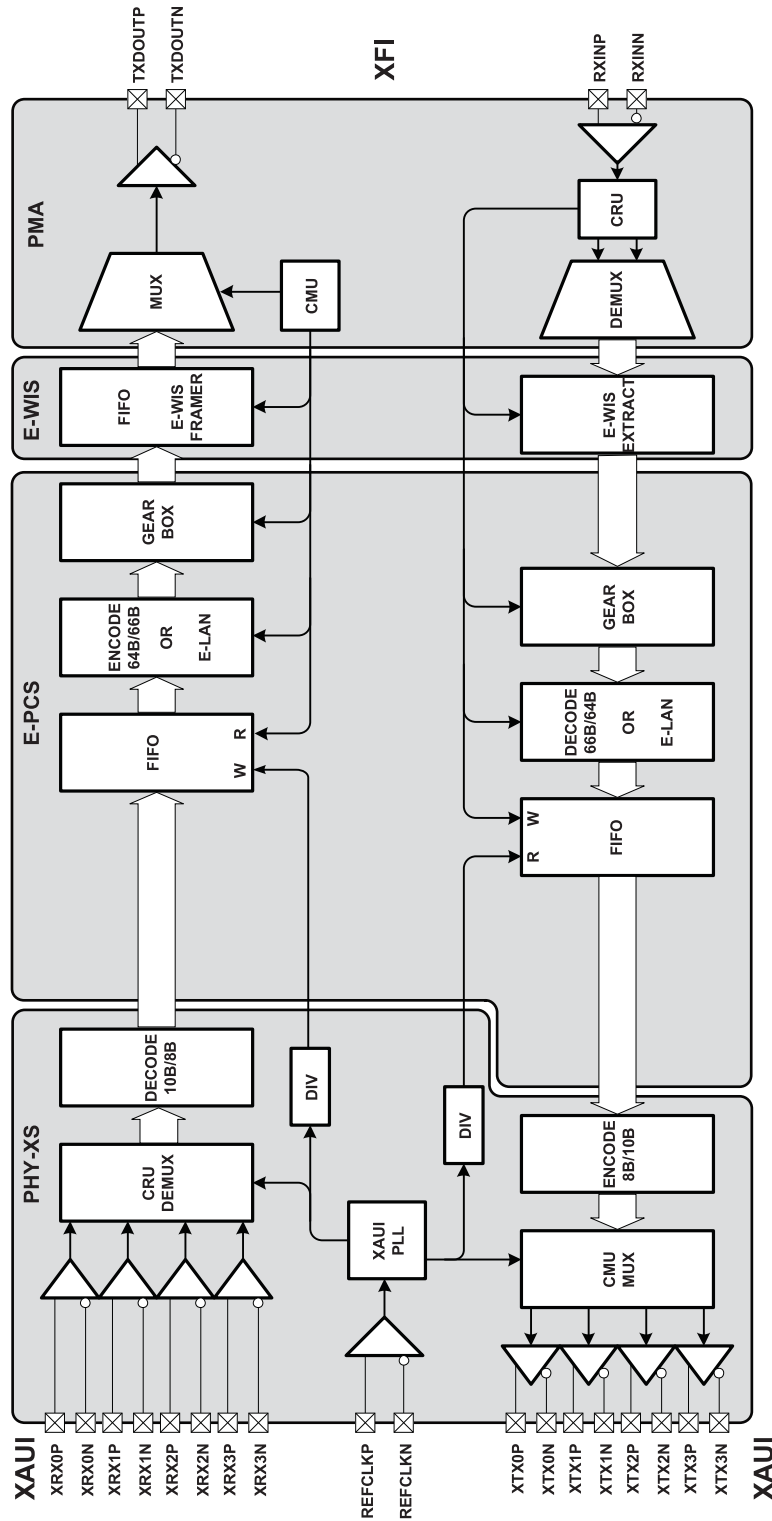

3.1.1 XAUI to XFI Mode

The following illustration shows the XAUI to XFI mode for the VSC8486-11 device.

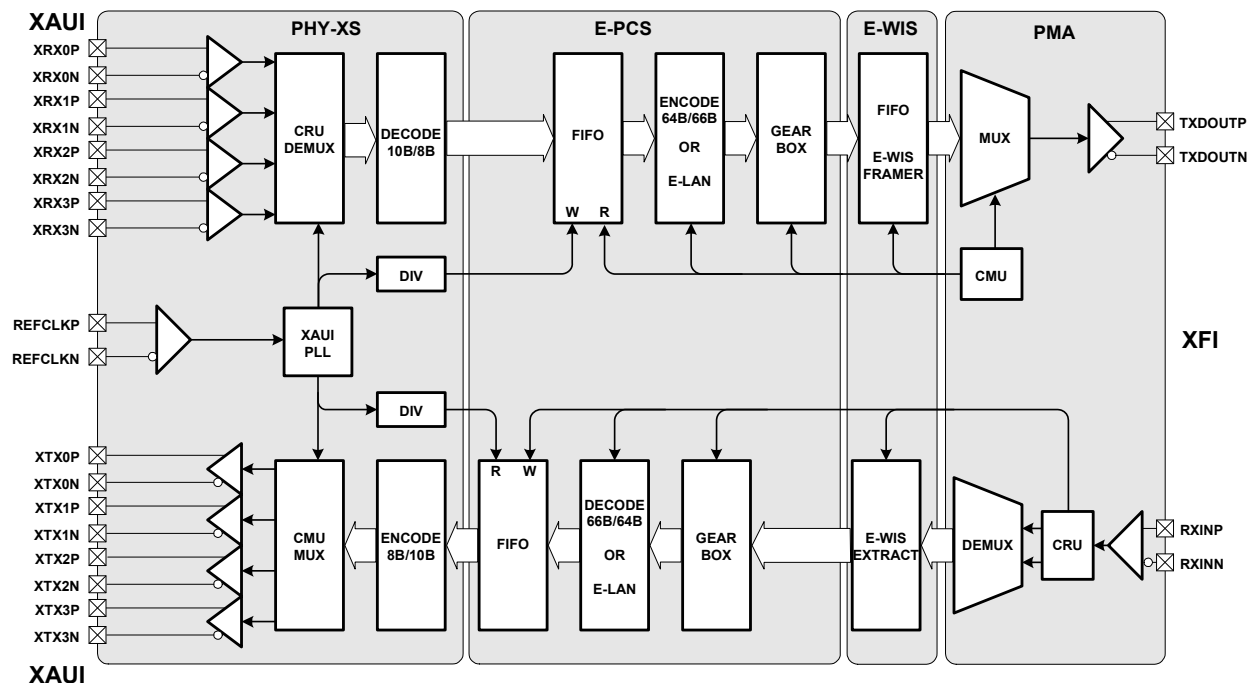
Figure 2 • Functions in XAUI to XFI Mode

3.1.1.1 Transmit Operation for XAUI to XFI Mode

As shown in the preceding illustration, the PHY XS block receives four 8b/10b encoded 3.125 Gbps (3.1875 Gbps in SAN mode) data lanes on pins $\text{XRX}[3:0]\text{P/N}$. The clock is recovered and the data is deserialized on each of the four lanes. Synchronization is performed before the data is passed into the 10b/8b decoders. The decoded data and accompanying control bits are then presented to the FIFO. The FIFO deskews the four lanes and presents the aligned data to the PCS.

The FIFO within the PCS transfers path timing from the PHY XS recovered clock to the PMA transmit clock by adding or deleting idle characters during inter-packet gaps (IPG) as needed. The eight data octets (8-bit characters) and eight control bits pass through the 64b/66b encoder, which maps data to a single 66-bit transmission block, as defined in Figure 49-7 of IEEE Standard 802.3ae.

In standard PCS mode ($\text{EPCS} = 0$), the first two bits of the 66-bit block contain the sync header, which is used to establish block boundaries for the synchronization process during the receive operation. The remaining 64 bits contain the payload. The payload passes through the scrambler, which implements the polynomial $G(x) = 1 + x^{39} + x^{58}$. The sync header bypasses the scrambler, and joins the scrambled payload at the 64:66 gearbox. The gearbox adapts between the 66-bit width of the blocks and the 64-bit width of the PMA or WIS interface.

In extended PCS mode ($\text{EPCS} = 1$), the 64 payload bits are mapped such that 24 instances of the 64-bit payloads are placed into a larger 1584-bit frame defined by the Optical Internetworking Forum (OIF) Common Electrical I/O Protocol (CEI-P). Each 64-bit payload is preceded by one transcoding bit, and the remaining 24 bits of the 1584-bit frame are used for synchronization, fire code parity check, supervisory channel, and to indicate the link state. This frame is then scrambled with a free-running linear feedback shift register (LFSR) scrambler with a characteristic polynomial $G(x) = x^{17} + x^{14} + 1$. The scrambled frame then passes through the 64:66 gearbox to the PMA or WIS.

In LAN or SAN mode ($\text{WAN_STAT} = 0$), the PCS data is passed directly to the PMA, while in WAN mode ($\text{WAN_STAT} = 1$), the PCS data is passed to the WIS. The WIS inserts the PCS data into SONET STS-192c/SDH STM-64 frames, and adds the required overhead.

Within the PMA, the data is serialized into the high-speed data stream (10.3125 Gbps in LAN mode, 10.51875 Gbps in SAN mode, and 9.95328 Gbps in WAN mode). The data stream and the divide-by-64 clock (161.13 MHz in LAN mode, 164.35 MHz in SAN mode, and 155.52 MHz in WAN mode) are provided for line transmission on pins TXDOUTP/N and CLK64AP/N , respectively.

3.1.1.2 Receive Operation for XAU1 to XFI Mode

High-speed, 10 Gbps NRZ serial data is received on pins RXINP/N where it can be equalized for copper trace dispersion and presented to the clock recovery unit (CRU).

In LAN and SAN mode (WAN_STAT = 0), the output of the CRU is deserialized and presented to the PCS, while in WAN mode (WAN_STAT = 1), the output of the CRU is deserialized and presented to the WIS. The WIS extracts the data from the SONET STS-192c/SDH STM-64 frames and processes the overhead. The resultant data is then presented to the PCS.

In standard PCS mode (EPCS_STAT = 0), the data enters the 66:64 gearbox. The 66-bit block is then aligned using the embedded 2-bit sync header, which generates the 64-bit payload. The payload is descrambled using the polynomial $G(x) = 1 + x^{39} + x^{58}$. The descrambled payload and 2-bit sync header pass through the 64b/66b decoder, where the block is mapped to valid data, eight data octets, and eight control bits.

In extended PCS mode (EPCS_STAT = 1), the data enters the PCS and is presented to the 66:64 gearbox. The data is then descrambled, framed, and formatted into 1584-bit frames. The Fire Code parity check code in the received data stream is used to delineate frame boundaries. Because the scrambler bits are XOR'ed with the FEC overhead during transmission, the state of the scrambler can be recovered by subtracting the calculated parity from the received scrambled parity. The block is then mapped to valid data, eight data octets, and eight control bits.

In both standard or extended PCS modes, the eight data octets and eight control bits are passed to the FIFO, where path timing is transferred from the divided (one sixty-fourth) recovered clock to the divided (one sixty-sixth) CMU clock. During IPG, idle characters are added or deleted as necessary to adapt between the two clock rates.

The eight data octets and eight control bits are then presented to the PHY XS block where it is 8b/10b encoded and serialized. The serialized code words are then transmitted four at a time on the four XAU1 outputs: XTX[3:0]P/N.

3.2 Loopback

The VSC8486-11 LAN PHY has two 10-gigabit data ports, XAU1 and XFI. There are several options available to the user for routing traffic between the various ports. The purpose of this section is to outline the operation of several modes loosely termed loopbacks. These modes can be extremely useful for both test and debug purposes.

In addition to loopbacks, the device contains several pins that configure the device for XAU1 operation without requiring MDIO access.

Loopback paths are illustrated in the following illustration. Two split loopback paths (that is, two loopback paths simultaneously switched on) are enabled by the SPLITLOOPN pin. Most other data path routing and loopback controls are enabled through the MDIO interface.

Figure 3 • Loopback Configuration

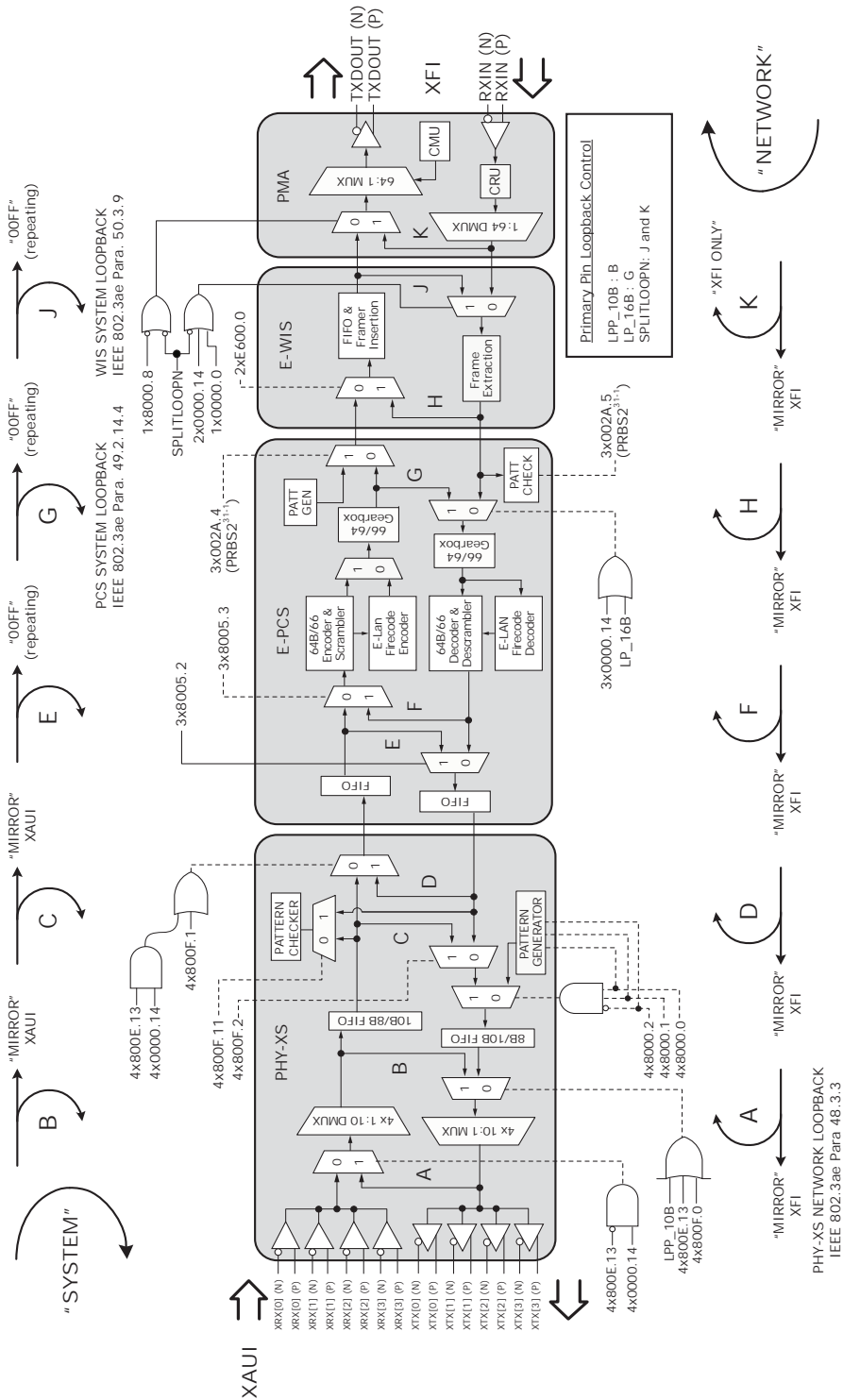

3.2.1 Loopback Modes

There are three types of loopback modes: system, network, and split loopbacks. In general, system loopbacks affect XAUI traffic, network loopbacks affect XFI traffic, and split loopbacks affect both. The following table provides a summary of the system loopbacks.

Table 1 • System Loopback Summary

Loopback	Name	Loopback Enable	Retiming
B	PHY XS shallow system loopback	Any of the following: LPP_10B = 1 4×800E.13 = 1 4×800F.0 = 0	Phase delay only, XAUI XTX[3:0] signals retimed from XAUI XRX[3:0] recovered clock
C	PHY XS deep system loopback	4×800F.2 = 1	XAUI XTX[3:0] signals retimed to LAN clock (REFCLKP/N)
E	PCS FIFO system loopback	3×8005.2 = 1	XAUI XTX[3:0] signals retimed to LAN clock (REFCLKP/N)
G	PCS system loopback	LP_16B = 1 or 3×0000.14 = 1	XAUI XTX[3:0] signals retimed to LAN clock (REFCLKP/N)
J	PMA/WIS system loopback	Any of the following: SPLITLOOPN = 0 (active low) 2×0000.14 = 1 1×0000.0 = 1	XAUI XTX[3:0] signals retimed to LAN clock (REFCLKP/N)

For system loopbacks, the XAUI data can be mirrored to the XFI Tx port, depending on the register setting of XFI_LPBK_OVR (1×EF10.2).

Table 2 • System Loopback and XFI Traffic

Loopback	If XFI_LPBK_OVR (1×EF10.2) = 0 ¹	If XFI_LPBK_OVR (1×EF10.2) = 1
B	XFI Tx traffic from WIS/PCS	XFI Tx traffic set by 1×EF10.1:0 00: 0×00FF pattern 01: All zeros 10: All ones 11: WIS/PCS
C	XFI Tx traffic from WIS/PCS	XFI Tx traffic set by 1×EF10.1:0 00: 0×00FF pattern 01: All zeros 10: All ones 11: WIS/PCS
E, G, or J	0×00FF pattern	XFI Tx traffic set by 1×EF10.1:0 00: 0×00FF pattern 01: All zeros 10: All ones 11: WIS/PCS

1. The XFI_LPBK_OVR (1×EF10.2) register defaults to 0.

The following table provides a summary of the network loopbacks, which primarily affect XFI traffic.

Table 3 • Network Loopbacks Summary

Loopback	Name	Loopback Enable	Retiming
A	PHY XS deep network loopback	4×0000.14 = 1 and 4×800E.13 = 0	See Table 5, page 10
D	PHY XS shallow network loopback	Any of the following: 4×800E.13 = 0 and 4×0000.14 = 0 4×800F.1 = 1	See Table 5, page 10
F	PCS gearbox network loopback	3×8005.3 = 1	See Table 5, page 10
H	WIS network loopback	2×E600.0 = 1	See Table 5, page 10
K	PMA network loopback	Any of the following: SPLITLOOPN = 0 (active low) 1×8000.8 = 0	See Table 5, page 10

Split loopback affects both XAUI and XFI traffic. Split loopback is enabled using the SPLITLOOPN pin, as shown in the following table.

Table 4 • Split Loopbacks Summary

Loopback	Name	Loopback Enable	Retiming
J and K	PMA split loopback	SPLITLOOPN = 0 Internally pulled high	See Table 5, page 10

3.2.1.1 Retiming Clock Sources for Network and Split Loopbacks

For network and split loopbacks, there are various options for controlling the XFI retiming, as shown in the following table. For retiming XAUI traffic (pins XTX[3:0]), REFCLKP/N is used; however, when the split loopback B and D is active, the recovered clock from XRX[3:0] is used.

Table 5 • Retiming Clock Sources for Network and Split Loopbacks

WAN_STAT (1×E606.15)	LINETIME_STAT (1×E606.13)	XFI Retimed With
0	0	REFCLKP/N
0	1	10G LINE_IN
1	0	WREFCLKP/N
1	1	10G LINE_IN

3.3 Loopback Paths

This section describes each loopback, listed in alphabetical order.

3.3.1 Loopback A

Loopback A is located in the XAUI PHY. It reroutes the data from the 10:1 MUX in the XAUI PHY into the 1:10 DEMUX, as shown in the following illustration. XFI data is retimed with PMA CRU. To enable loopback A, set both of the following: LPBK_A (4×0000.14) set to 1 and LPBK_B (4×800E.13) set to 0. The default value for bit 14 is 0 (loopback disabled). XFI ingress (RXINP/N) data is mirrored to the XAUI egress port (XTX[3:0]P/N) simultaneously without further MDIO instructions. Loopback A cannot be used if LP_XAUI is asserted high.

Note: For proper function of loopback A without a XAUI input present, the XS Rx signal detection register 4×E600.1 must be set to 1 for the XAUI inputs to sync up.

Figure 4 • PHY XS Deep Network Loopback

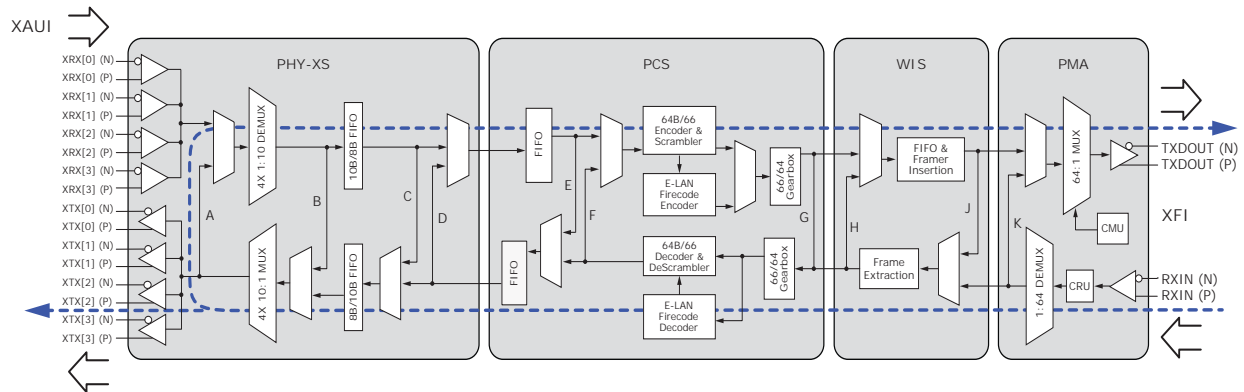

3.3.2 Loopback B

Loopback B routes the incoming XAUI data through the 1:10 DEMUX and then loops back before the 10b/8b decoder into the 10:1 MUX. Data is retimed by the recovered XAUI clock. No 10b/8b decoding or lane synchronization is performed. System XAUI data is also mirrored to the XFI Tx port. To enable loopback B, set the LPBK_B register (4×800E.13) to 1 or the LPP_10B pin to high.

Figure 5 • PHY XS Shallow System Loopback

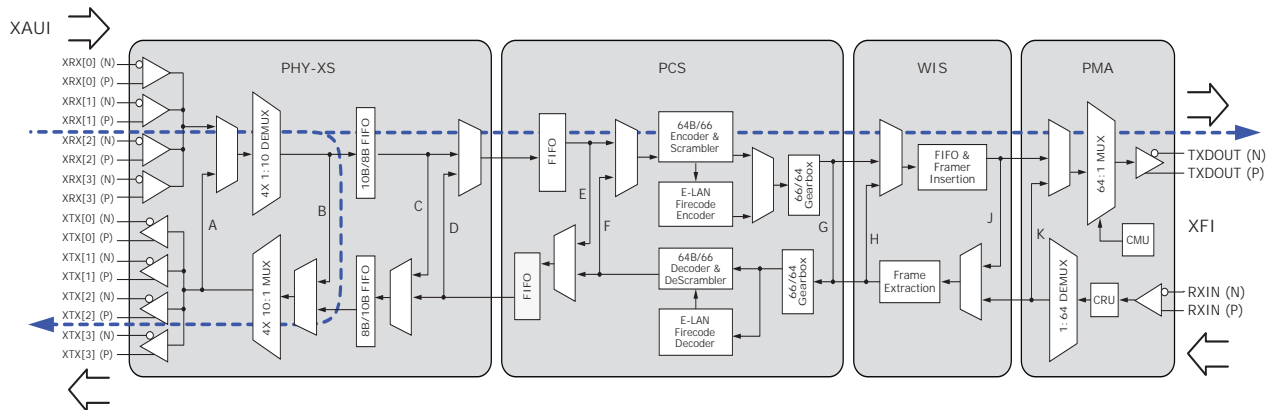

3.3.3 Loopback C

Loopback C routes the incoming XAUI data after the 10b/8b FIFO back into the 8b/10b FIFO. System XAUI data is also mirrored to the XFI Tx port. To enable loopback C, set LPBK_C (4×800F.2) to 1.

Figure 6 • PHY XS Deep System Loopback

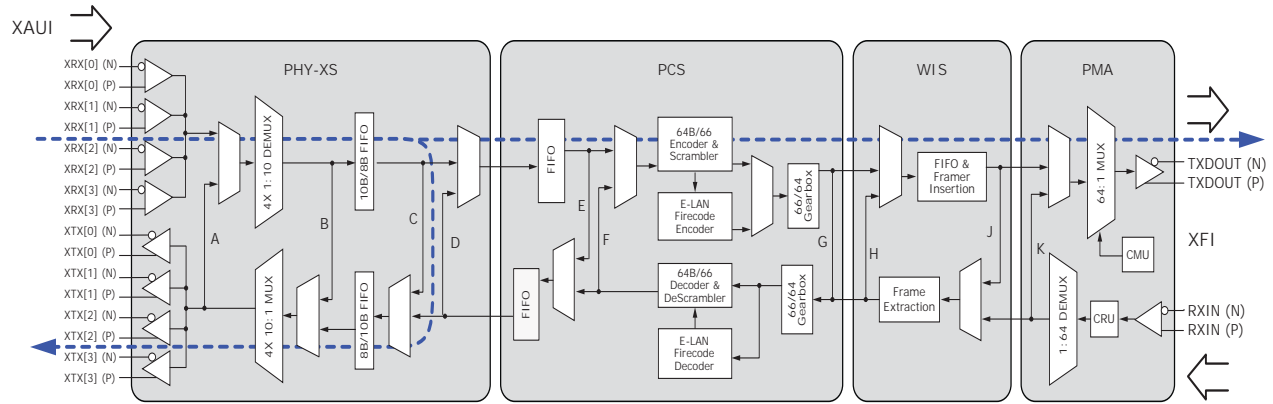

3.3.4 Loopback D

Loopback D routes the incoming XFI data after the PCS FIFO back into the transmit PCS FIFO. Network XFI Rx data is also mirrored to the XAUI egress port. To enable loopback D, set either the LPBK_D register (4x800F.1) to 1 or both the LPBK_B (4x800E.13) and LPBK_A (4x0000.14) registers to 1.

Figure 7 • PHY XS Shallow Network Loopback

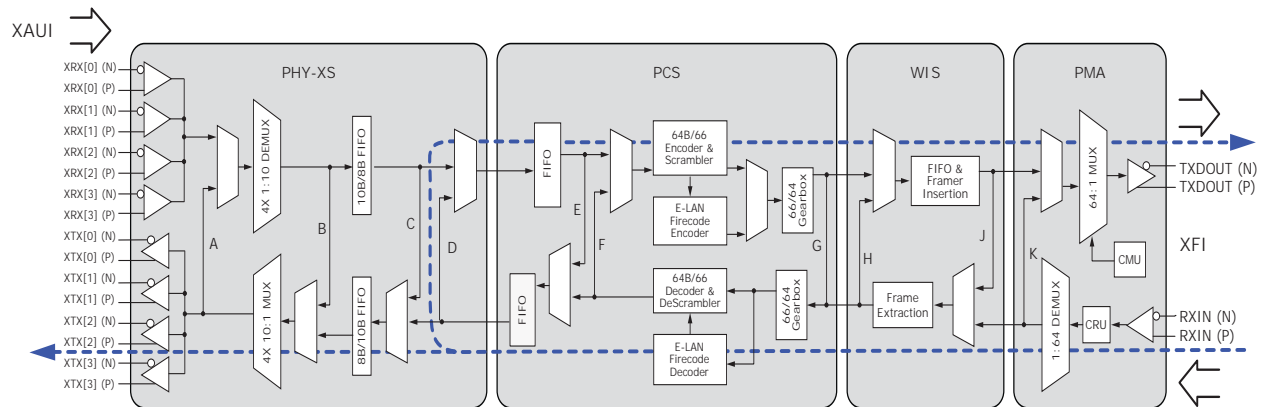

3.3.5 Loopback E

Loopback E routes the incoming XAUI data from the PCS transmit FIFO back into the PCS receive FIFO. The data transmitted to the XFI Tx port is a continuous stream of 0x00FF data words. To enable loopback E, set LPBK_E (3x8005.2) to 1.

Figure 8 • PCS FIFO System Loopback

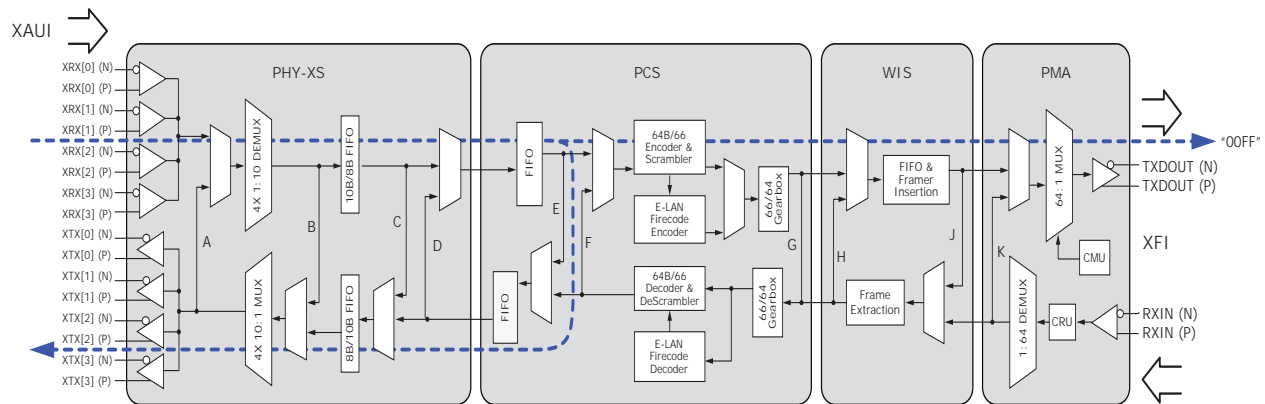

3.3.6 Loopback F

Loopback F routes the incoming XFI data after the receive PCS gearbox back into the transmit PCS gearbox. Network XFI Rx data is also mirrored to the XAUI egress port. To enable loopback F, set LPBK_F (3×8005.3) to 1.

Figure 9 • Gearbox Network Loopback

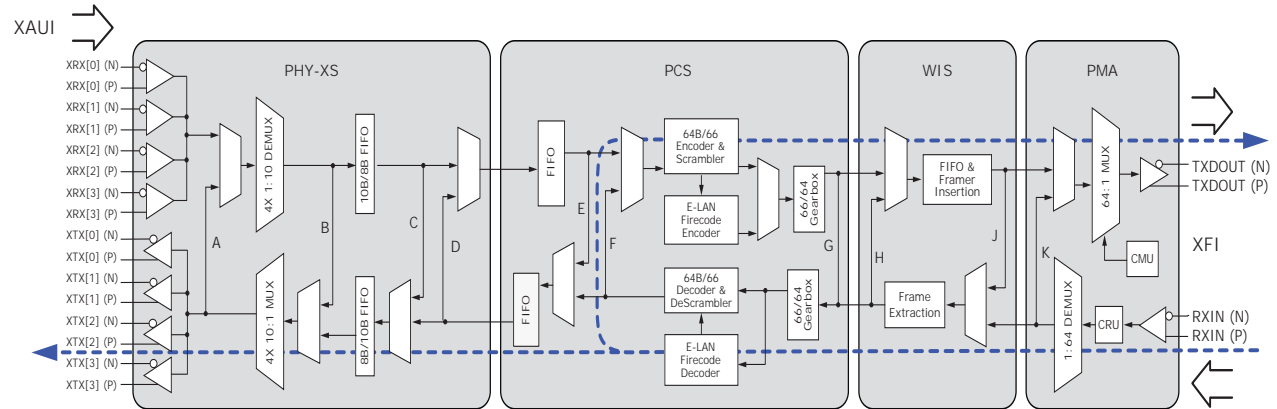

3.3.7 Loopback G

Loopback G routes the incoming XAUI data through the PCS transmit gearbox back into the PCS receive gearbox. The data transmitted to the XFI Tx port is a continuous stream of 0×00FF data words. To enable loopback G, either set LPBK_G (3×0000.14) to 1 or set the LP_16B pin high.

Figure 10 • PCS System Loopback

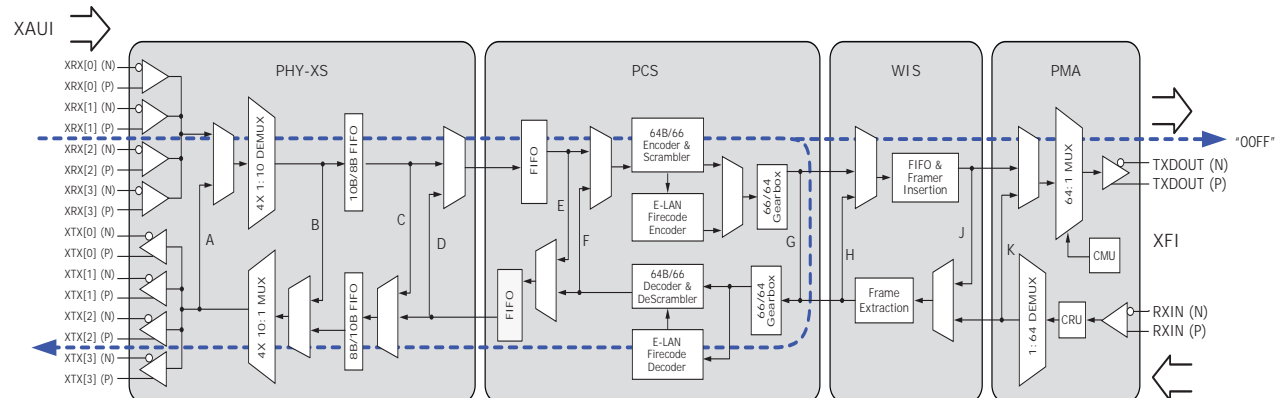

3.3.8 Loopback H

Loopback H routes the incoming XFI data from the PMA or WIS received data back into the PMA or WIS transmit path. Network XFI Rx data is also mirrored to the XAUI egress port. To enable loopback H, set LPBK_H (2×E600.0) to 1.

Note: For proper function of Loopback H in path generation and termination, the VSC8486-11 device must not receive frames in which the payload pointer is incremented or decremented. The Tx SONET frame for the VSC8486-11 should always have the payload pointer in a fixed location (522), otherwise the Tx and Rx paths will not be frequency-locked. When the Tx and Rx paths are not frequency-locked, the Rx WIS can receive a different number of bytes than the Tx WIS sends out, resulting in an overflow/underflow condition.

Figure 11 • PCS System Loopback

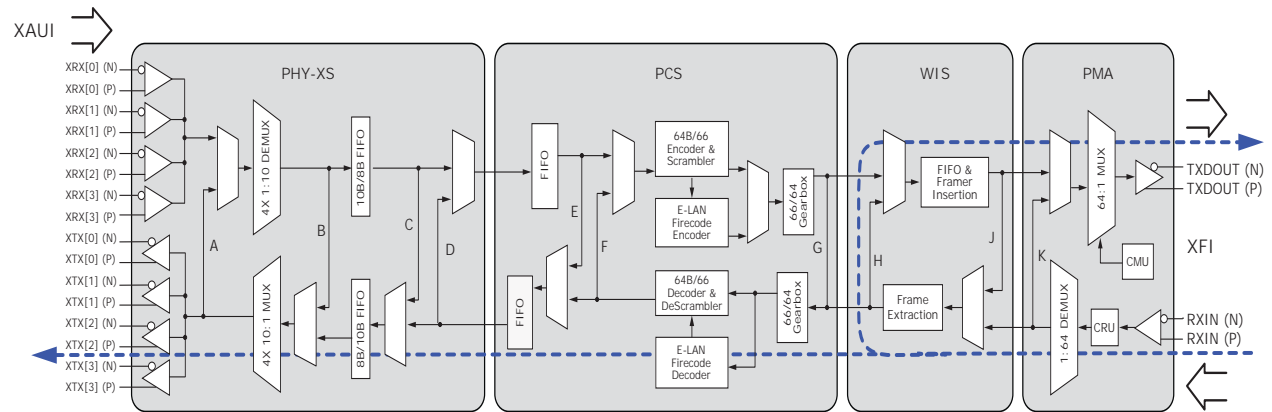

3.3.9 Loopback J

Loopback J routes the incoming XAUI data from the PCS (or WIS if enabled) back into the PCS (or WIS if enabled). This loopback is enabled for both PMA and WIS system loopbacks. The data transmitted to the XFI Tx port is a continuous stream of 0x00FF data words. To enable loopback J, set any of the following: LPBK_J_PMA (1x0000.0) set to 1 or LPBK_J_WIS (2x0000.14) set to 1 or the SPLITLOOPN pin set low. Setting the SPLITLOOPN pin low also enables loopback K.

Figure 12 • PMA/WIS System Loopback

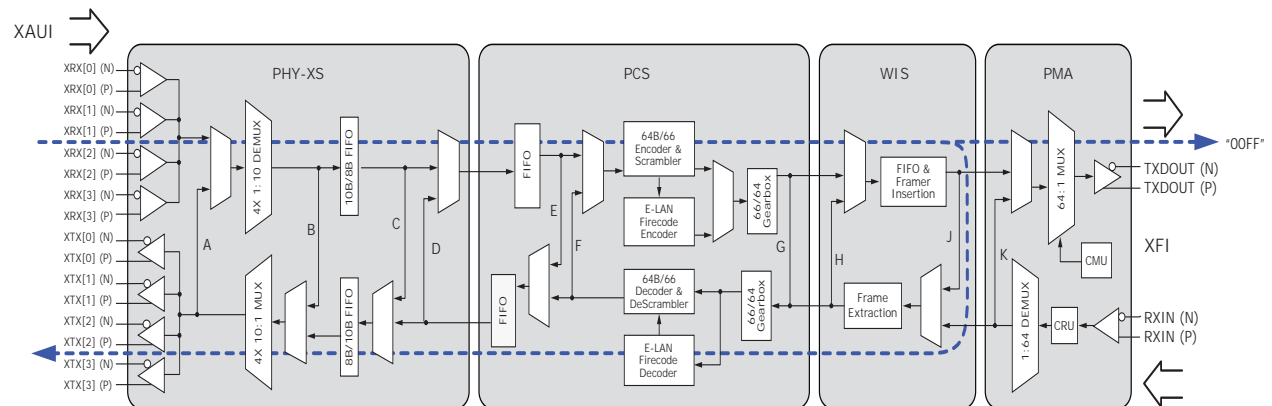

3.3.10 Loopback K

Loopback K routes the incoming 10-gigabit XFI data back to the 10-gigabit XFI output, as shown in the following illustration. Loopback K is protocol agnostic. Data is retimed with the 10-gigabit recovered clock. Network XFI Rx data is also mirrored to the XAUI egress port. To enable loopback K, set any of the following: LPBKN_K (1x8000.8) set to 0 (the default is 1, disabled) or set the SPLITLOOPN pin low. Setting the SPLITLOOPN pin low also enables loopback J.

Figure 13 • PMA Network Loopback

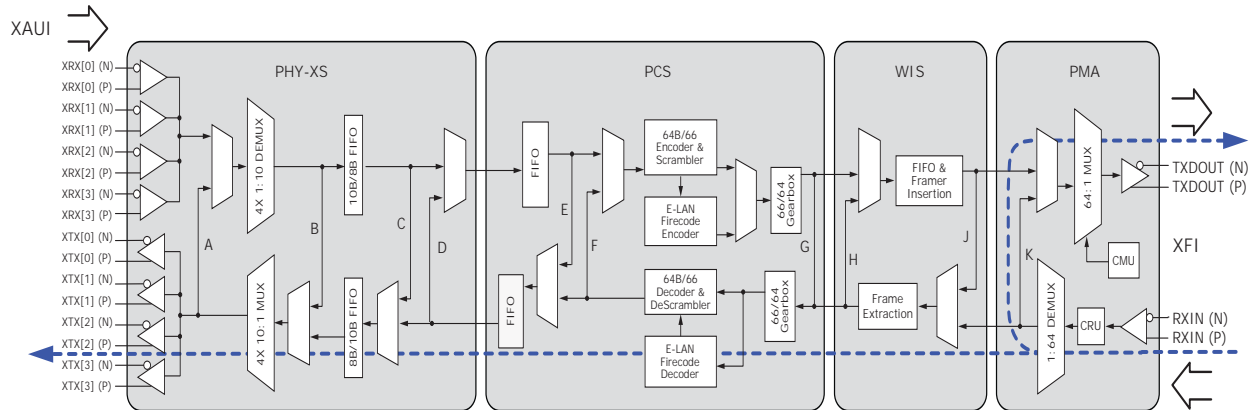

3.3.11 PMA Split Loopbacks J and K

Split loopback paths J and K are simultaneously enabled by setting SPLITLOOPN low. Loopback J recovers the clock from the XAUI ingress data, passes through a rate compensation FIFO, and is timed out by the LAN REFCK. Loopback K is retimed by the 10-gigabit recovered clock. If left unconnected, the SPLITLOOPN input is pulled up on chip, disabling these loopback paths.

Figure 14 • PMA Split Loopback (SPLITLOOPN = 0)

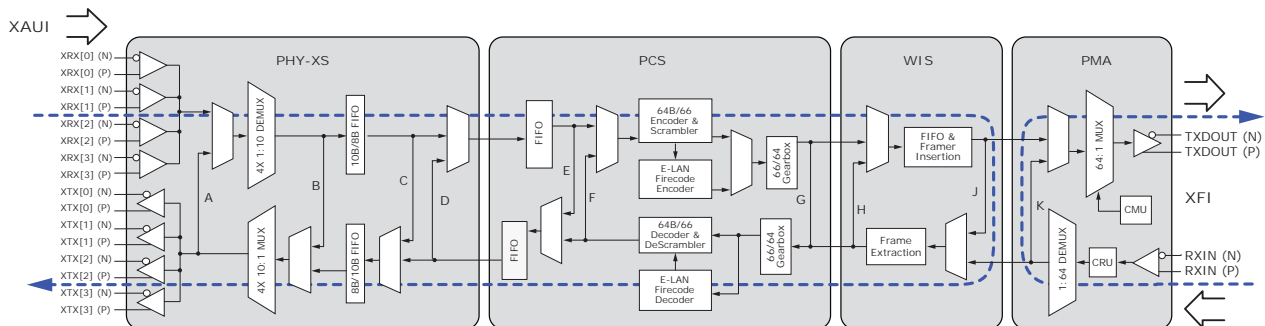

3.4 Physical Media Attachment

The following block diagram shows the physical media attachment (PMA).

Figure 15 • PMA Block Diagram

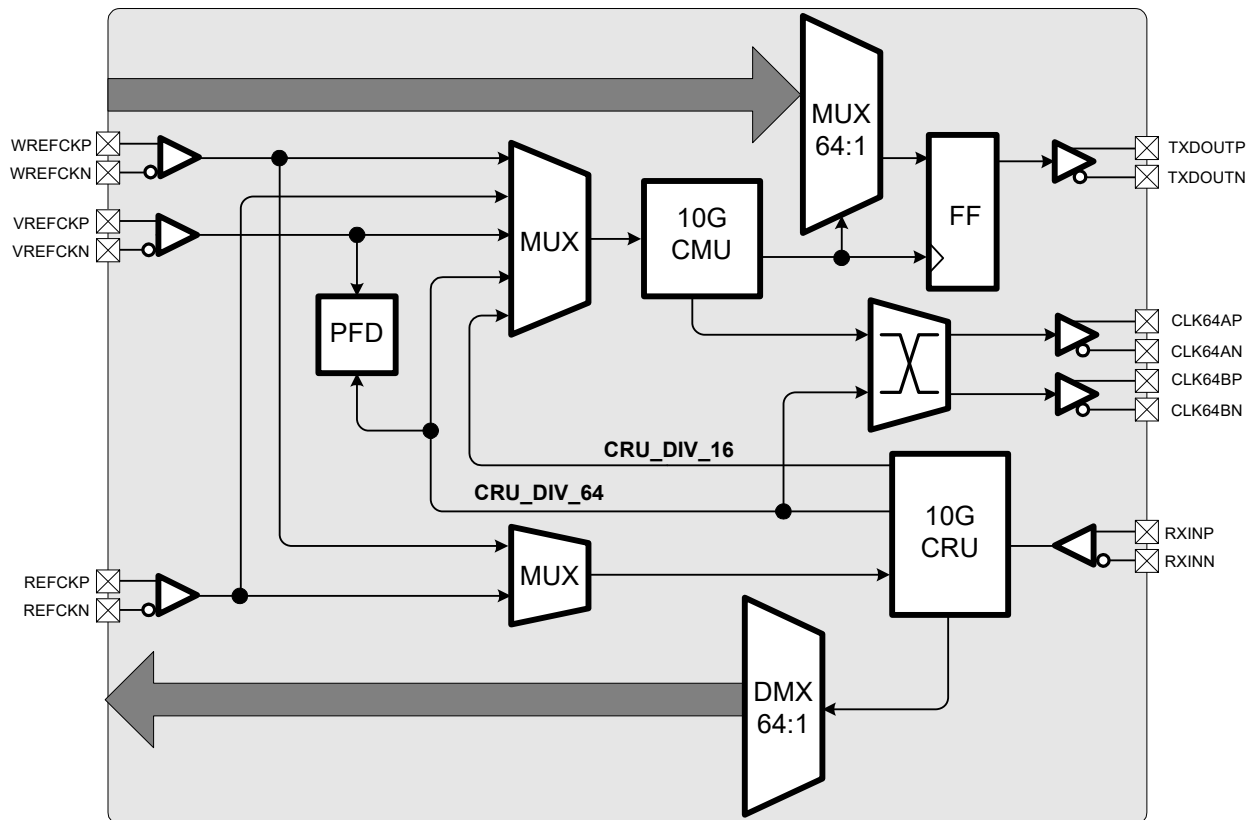

3.4.1 Multiplexer Operation

The PMA transmitter includes a CMU and a 64-bit multiplexer that receives 64-bit data from the PCS (or WIS) block, which generates the high-speed serial output on pins TXDOUPT/N. The output speeds are 10.3125 Gbps in LAN mode, 10.51875 Gbps in SAN mode, or 9.95328 Gbps in WAN mode.

The CMU provides a divide-by-64 clock output on pins CLK64AP/N or CLK64BP/N for optional use as a reference clock to an XFP module or external phase lock loop circuit. The clock output speeds are 161.133 MHz in LAN mode, 164.355 MHz in SAN mode, or 155.52 MHz in WAN mode.

By default, TX_MSBSEL (1×8000.6) is set to 1, resulting in the PMA transmitting the least significant bit (LSB) first. Using MDIO, the most significant bit (MSB) can be selected as the first bit transmitted.

The high-speed output data (TXDOUPT/N) can be muted (that is, set to continuous zeros) by setting 1×E605.9:8.

3.4.2 Timing Operation

The VSC8486-11 supports two types of timing operation, normal and linetime. During normal timing, with LINETIME_STAT (1×E606.13) = 0, the device transmits data synchronous to the REFCLKP/N or WREFCLKP/N input if in WAN mode (1×E606.14). In linetime mode (LINETIME_STAT = 1), the device transmits data synchronous to the receiver's recovered clock. The VSC8486-11 provides the necessary divided-down clock outputs to enable users to synthesize an external phase lock loop jitter attenuation circuit. A voltage controlled SAW oscillator (VCSO) is recommended for optimum phase noise and jitter performance. The VCSO frequency must be 622.08 MHz and connected to the VREFCLKP/N pins.

The default state for the LINETIME_FRC bit (1×E605.4) is 0 (linetime disabled). To enable linetime, set this bit to 1. The linetime status bit (1×E606.13) shows the linetime status.

3.4.3 Reference Clock Rate Selection

The VSC8486-11 supports two WAN mode reference clock rate options. By default, REFSEL0 controls the REFSEL0_STAT state. The pin control has various overrides, as listed in the following table (X indicates “doesn’t matter”).

Table 6 • REFSEL0_STATUS Logic

Inputs			Result	
REFSEL0	REFSEL0_OVR (1×E605.7)	REFSEL0_FORCE (1×E605.6)	WREFCLK Frequency	REFSEL0_PIN_STATUS (1×E606.12)
Low (default)	0 (default)	X	622.08 MHz	0
High	0	X	155.52 MHz	1
X	1	0	622.08 MHz	X
X	1	1	155.52 MHz	X

3.4.4 WAN Mode

By default, the WAN_MODE controls the WAN_STAT state. The pin control has various overrides, as listed in the following table (where X indicates “doesn’t matter”).

Note: When written, registers 2×0007 and 3×0007 provide a microcontroller interrupt.

Table 7 • WAN Mode Control Logic

Inputs				Result	
PCS Type Selection (2×0007.0)	PCS Mode (3×0007.1:0)	WAN_OVR (1×E605.3)	WAN_FORCE (1×E605.2)	WAN_STAT (1×E606.15)	WAN_MODE_ PSTAT (1×E606.14)
0	00	0	X	0	0
X	X	0	X	1	1
X	X	1	0	0	X
X	X	1	1	1	X
1	X	0	X	1	X
X	10	0	X	1	X
0	00	0	X	0	0

3.4.5 Clock Multiplier Unit Reference Clocking

For LAN and SAN applications (WAN_STAT = 0), an on-chip PLL generates the high-speed transmit clock from the externally provided REFCLKP/N input during normal timing operation or from the recovered high-speed receive clock during linetiming operation. The REFCLKP/N input must be one sixty-sixth of the serial data rate (156.25 MHz for LAN mode or 159.375 MHz for SAN mode). The XAUI transmitter and receiver also use the REFCLKP/N input.

For WAN applications (WAN_STAT = 1), an additional reference clock is required for the high-speed data (9.95328 Gbps). The on-chip PLL generates the high-speed transmit clock from one of three sources: the externally provided WREFCLKP/N input, the recovered high speed receive clock, or from an external VCISO as part of a jitter attenuation PLL circuit that enters the device at VREFCLKP/N. In both normal timing operation and in linetiming operation, the WREFCLKP/N reference clock must be present and can be either 155.52 MHz (REFSEL0 = 1) or 622.08 MHz (REFSEL0 = 0, which is the default). In linetiming operation (LINETIME_STAT = 1), the transmit clock is generated from the 10-gigabit CRU. As with LAN and SAN modes, the XAUI clock is generated from the REFCLKP/N input.

The on-chip PLL uses a low phase noise reactance-based VCO. The reference clock should be of high quality because noise on the reference clock below the PLL loop bandwidth passes through the PLL and appears as jitter on the outputs (TXDOUTP/N and CLK64AP/N). During such conditions, the VSC8486-11 transfers reference clock noise in addition to its own intrinsic jitter. Preconditioning the reference clock signal might be necessary to avoid passing reference clock noise.

The following table summarizes these reference clock controls and the associated frequencies. The transmit and receive references are also provided.

Table 8 • CMU and CRU Reference Clock Control and Frequency Summary

Mode Description	LINE TIME_S TAT	WAN_S TAT	REFSEL0 _STATUS	REFCLKP, REFCLKN, (MHz)	WREFCLKP, WREFCLKN (MHz)	Transmit Reference (10G CMU)	Receive Reference (10G CRU)
1: LAN/SAN mode, normal timing	0	0	X	156.25 or 159.375	NC	REFCLKP, REFCLKN	REFCLKP, REFCLKN
2: WAN mode, normal timing	0	1	0	156.25	622.08	WREFCLKP, WREFCLKN	WREFCLKP, WREFCLKN divided by 4
3: WAN mode, 155.52 MHz reference clock normal timing	0	1	1	156.25	155.52	WREFCLKP, WREFCLKN	WREFCLKP, WREFCLKN
4: LAN/SAN mode, linetiming	1	0	0	156.25 or 159.375	NC	CRU recovered clock divided by 64	REFCLKP, REFCLKN
5: LAN/SAN mode, linetiming	1	0	1	156.25 or 159.375	NC	CRU recovered clock divided by 16	REFCLKP, REFCLKN
6: WAN mode, linetiming with external jitter attenuation circuit	1	1	0	156.25	622.08	VREFCLKP, VREFCLKN (only at 622.08 MHz)	WREFCLKP, WREFCLKN divided by 4
7: WAN mode, linetiming with 155.52 reference clock	1	1	1	156.25	155.52	CRU recovered clock divided by 16	WREFCLKP, WREFCLKN

3.4.6 Reference Clock Inputs

The VSC8486-11 determines the PMA timing mode by decoding the inputs for LINETIME_STAT, WAN_STAT, and REFSEL0_STATUS. The following tables define the logic for these three inputs and the available modes. VSC8486-11 always requires a 156.25 MHz (159.375 MHz) reference clock applied to REFCLKP/N for all operating modes.

3.4.6.1 LAN/SAN Only

For applications supporting LAN/SAN only, we recommend the configuration depicted in the following table. WAN mode is not supported by this configuration. The input signals for this configuration are:

- REFCLKP/N = 156.25 MHz or 159.375 MHz
- WREFCLKP/N = none
- VREFCLKP/N = none

In the following tables, X indicates “doesn’t matter.”

Table 9 • Configuration for LAN/SAN Only

LINETIME_ STAT	WAN_S TAT	REFSELO_ STATUS	Transmit Reference (10G CMU)	Receive Reference (10G CRU)	Mode Description
0	0	X	REFCLKP/N	REFCLKP/N	Normal timing, LAN/SAN mode
1	0	0	CRU divided by 64	REFCLKP/N	Linetime, LAN, or SAN mode
1	0	1	CRU divided by 16	REFCLKP/N	Linetime, LAN, or SAN mode

3.4.6.2 LAN/SAN/WAN With SONET/SDH Jitter Generation Compliance

For applications that require SONET/SDH jitter performance but do not require clock cleanup, we recommend the configuration depicted in the following table. In this configuration, the 622.08 MHz clock provides the best jitter generation performance. This configuration does not support clock cleanup in linetime mode. The input signals for this configuration are:

- REFCLKP/N = 156.25 MHz or 159.375 MHz
- WREFCLKP/N = 622.08 MHz
- VREFCLKP/N = none

Table 10 • Configuration With SONET/SDH Jitter Generation Compliance

LINETIME_ STAT	WAN_S TAT	REFSELO_ STATUS	Transmit Reference (10G CMU)	Receive Reference (10G CRU)	Mode Description
0	0	X	REFCLKP/N	REFCLKP/N	Normal timing, LAN/SAN mode
0	1	0	WREFCLKP/N	WREFCLKP/N	Normal timing, WAN mode
1	0	0	CRU divided by 64	REFCLKP/N	Line timing, LAN/SAN mode
1	0	1	CRU divided by 16	REFCLKP/N	Line timing, LAN/SAN mode

3.4.6.3 LAN/SAN/WAN Without SONET/SDH Jitter Generation Compliance

For applications that do not need to meet SONET/SDH jitter requirements and do not need to use the recovered clock, we recommend the configuration depicted in the following table. In this configuration, the 155.52 MHz clock does not provide the best jitter generation performance. This configuration does not support clock cleanup in linetime mode. The input signals for this configuration are:

- REFCLKP/N = 156.25 MHz or 159.375 MHz
- WREFCLKP/N = 155.52 MHz
- VREFCLKP/N = none

In the following table, X indicates “doesn’t matter.”

Table 11 • Configuration Without SONET/SDH Jitter Generation Compliance

LINETIME_ STAT	WAN_S TAT	REFSEL0 _STATUS	Transmit Reference (10G CMU)	Receive Reference (10G CRU)	Mode Description
0	0	X	REFCLKP/N	REFCLKP/N	Normal timing, LAN/SAN mode
0	1	1	WREFCLKP/N	WREFCLKP/N	Normal timing, WAN mode
1	0	0	CRU divided by 64	REFCLKP/N	Line timing, LAN/SAN mode
1	0	1	CRU divided by 16	REFCLKP/N	Line timing, LAN/SAN mode
1	1	1	CRU divided by 16	WREFCLKP/N	Line timing, WAN mode

3.4.6.4 LAN/SAN/WAN With Full SONET/SDH Jitter Compliance

For applications that require full SONET/SDH quality jitter in normal and lincetime modes, we recommend the configuration depicted in the following table. The input signals for this configuration are:

- REFCLKP/N = 156.25 MHz or 159.375 MHz
- WREFCLKP/N = 622.08 MHz
- VREFCLKP/N = 622.08 MHz

Table 12 • Configuration With Full SONET/SDH Jitter Compliance

LINETIME_ STAT	WAN_S TAT	REFSEL0 _STATUS	Transmit Reference (10G CMU)	Receive Reference (10G CRU)	Mode Description
0	0	X	REFCLKP/N	REFCLKP/N	Normal timing, LAN mode
0	1	0	WREFCLKP/N	WREFCLKP/N	Normal timing, WAN mode
1	0	0	CRU/64	REFCLKP/N	Normal timing, LAN mode
1	0	1	CRU/16	REFCLKP/N	Normal timing, LAN mode
1	1	0	VREFCLKP/N	WREFCLKP/N	Line timing WAN mode

The incoming low-speed reference clock (REFCLKP/N) is received by a differential LVPECL buffer as shown in [Figure 16](#), page 21.

The on-chip termination is 100 Ω equivalent between true and complement. An internal bias generator, nominally set at $0.67 \times VDD12TX$, is provided for AC-coupling. An internal termination tap, REFTERM, is provided to allow adjustment of the input common-mode voltage. It is recommended to add an external capacitor between REFTERM, and VDD or ground. Single-ended reference clock operation is possible, and when implemented, both inputs must have equivalent termination. However, the best jitter performance is obtained using a low phase noise, differential reference clock.

When interfacing with 3.3 V LVPECL clock sources, always use AC coupling capacitors in series with true and complement reference clock inputs on the VSC8486-11. The recommended ceramic capacitor value is 0.1 μF, size 0402.

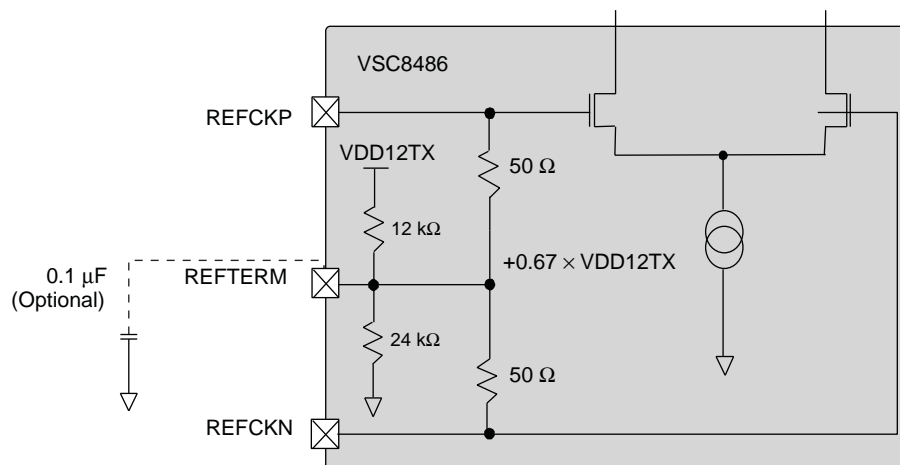
Figure 16 • Reference Clock Input Receiver

3.4.7 External Capacitors

For loop filter control and for minimizing the impact of power supply noise and other common-mode noise, the on-chip PLLs require 1.0 μF external capacitors. The external capacitors must be connected between pins CMUFILT and ground for the CMU, and between CRUFILT and ground for the CRU. These capacitors should be a multilayer ceramic dielectric with at least a 5 V working voltage rating. X7R dielectric capacitors provide better temperature stability and are recommended for this application.

3.4.8 XFI Transmit Data CML Output

The CML high-speed data output driver consists of a differential pair designed to drive a 50 Ω transmission line. As shown in the following illustration, the output driver uses an on-chip source termination of 50 Ω to VDD12TX, which minimizes any reflections.

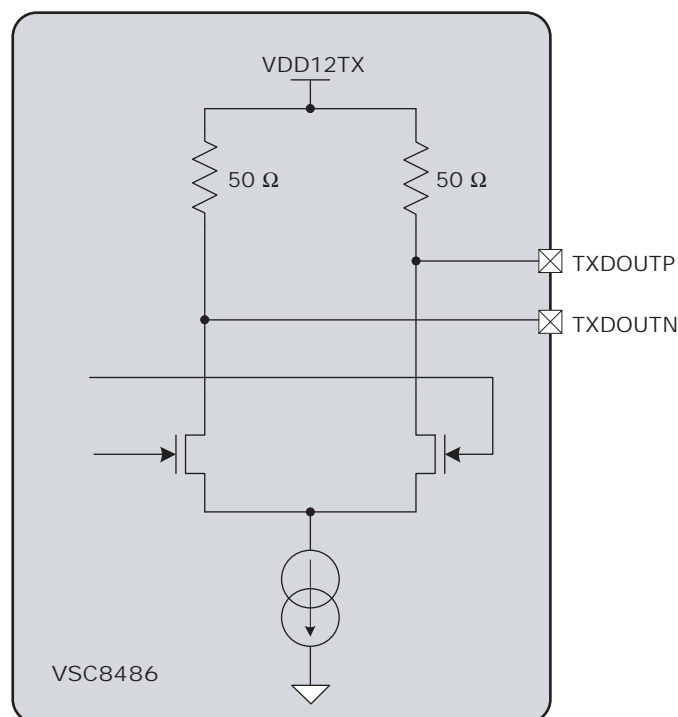
Figure 17 • CML XFI Output Driver

For single-ended operation at the transmitter, the unused TXDOUTP or TXDOUTN signal must be terminated either to VDD in DC couple mode or with a resistor to ground in AC couple mode. The resistor

to ground must have a value equal to the characteristic impedance of the copper transmission channel. The TXDOUTP/N outputs can be forced to a static level by controlling 1xE605.9:8.

3.4.9 XFI Transmitter Pre-Emphasis and Slew Rate

The XFI output stage includes programmable pre-emphasis, which affects the peaking and decay time (slew rate) of the transmitted bit. The following illustration shows the de-emphasized waveform. The illustration is for reference only and is not intended to represent an actual waveform.

Figure 18 • XFI Data Transmitter Differential Voltage with Pre-Emphasis

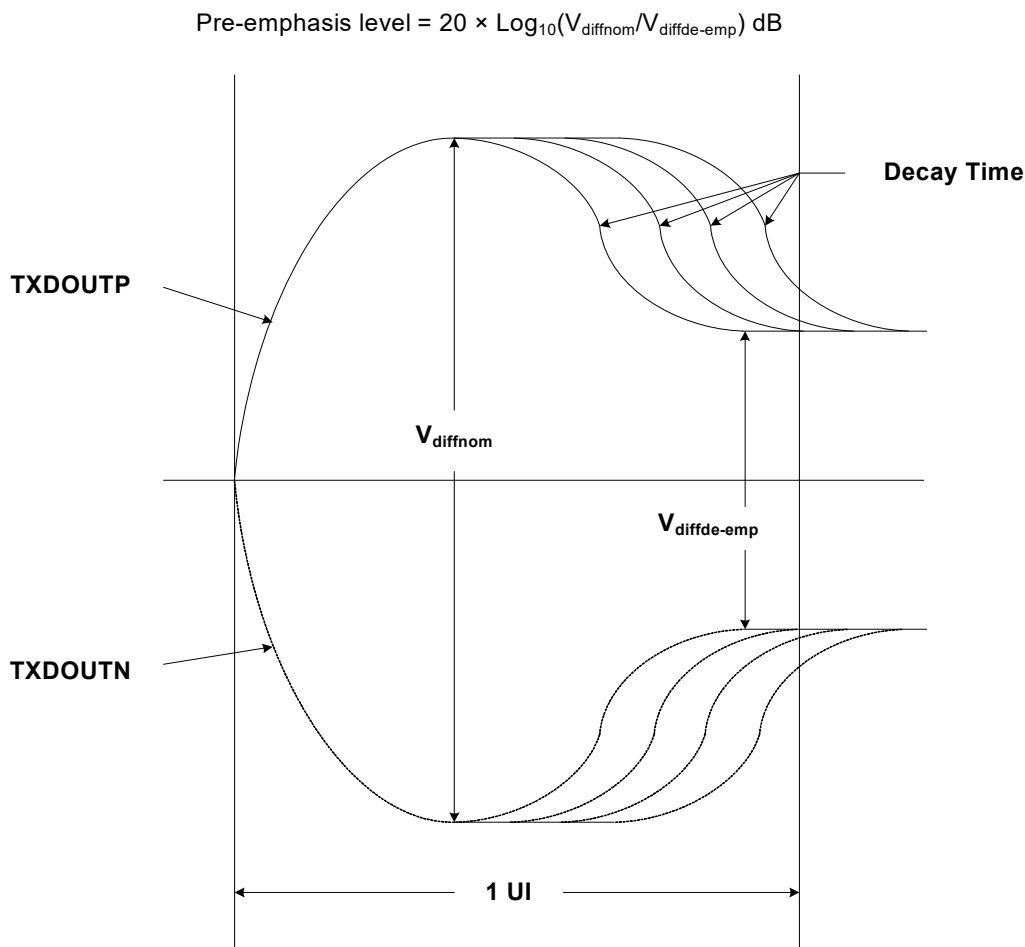

When used, transmit pre-emphasis shapes the XFI transmitter signal to mitigate dielectric and skin-effect distortion and loss. When signal pre-emphasis is employed, the effects of peaking predistortion offsets dielectric and skin-effect distortion, and a higher quality waveform results at the receiving device.

XFI transmitter pre-emphasis settings are programmed by writing to eight bits in register 1xE601[7:0]. The four least significant bits select the inductive peaking level and the four most significant bits adjust the pre-emphasis ratio. Recommended pre-emphasis settings are shown in the following table, along with approximate ratios.

Table 13 • XFI Transmitter Pre-Emphasis Ratio

Setting for Pre-Emphasis Ratio Bits 1xE601.7:4	Setting for Inductor Bits (Slew Rate) 1xE601.3:0	Approximate Ratios
0000 (default)	0000	1.8 dB

Table 13 • XFI Transmitter Pre-Emphasis Ratio (continued)

Setting for Pre-Emphasis Ratio Bits 1×E601.7:4	Setting for Inductor Bits (Slew Rate) 1×E601.3:0	Approximate Ratios
0100	0000	2.7 dB
1000	0000	3.3 dB
1111	0000	3.9 dB
0000 (default)	1111	3.8 dB
0100	1111	4.8 dB
1000	1111	6.2 dB
1111	1111	6.4 dB

As a guideline, the default setting is normally sufficient to drive 1 to 2 inches of stripline or microstrip transmission line in FR-4. XFI channels with transmission lines that exceed about 2 inches can benefit from increased pre-emphasis adjustment.

3.4.10 Line Rate Divided Clock Outputs

Several divided-down clocks can be selected to exit the VSC8486-11 at each of two CML clock outputs called CLK64AP/N and CLK64BP/N. Both clock outputs can be disabled using MDIO. CLK64AP/N also has a pin disable: CLK64A_EN. CLK64AP/N, which is normally used to provide an XFP reference clock, defaults to enabled and routes one sixty-fourth of the CMU clock rate.

Each clock output driver consists of a differential pair designed to drive a 50 Ω transmission line. Like the high-speed clock output, the output drivers are source-terminated on chip (50 Ω to VDD12TX) to absorb any reflections.

For single-ended operation at the transmitter, the unused output signal must be terminated as close as possible to the characteristic impedance of the transmission line used, which is normally 50 Ω.

The CLK64AP/N and CLK64BP/N outputs provide a similar set of clock signals. CLK64AP/N outputs are normally used for the XFP reference clock. The following table shows the enable and select control logic and available clock outputs for CLK64AP/N.

Table 14 • CLK64AP/N Clock Output

TCLKA_EN_SRC (1×E602.6)	TCLKA_EN_REG (1×E602.9)	CLK64A_EN Pin	TCLKA_SEL (1×E602.8:7)	CLK64AP/N Output
0	X	0	xx	Disabled
0 (default)	X	1 (default)	00 (default)	CMU clock divided by 64
0	X	1	01	CMU clock divided by 66
0	X	1	10	CRU clock divided by 64
0	X	1	11	REFCK reference clock
1	0 (default)	X	xx	Disabled
1	1	X	00	CMU clock divided by 64
1	1	X	01	CMU clock divided by 66
1	1	X	10	CMU clock divided by 64
1	1	X	11	REFCK reference clock

The following table provides the enable and select control logic and available clock outputs for CLK64BP/N.

Table 15 • CLK64BP/N Clock Output

TCLKB_EN (1×E602.5)	TCLKB_SEL (1×E602.4:3)	CLK64BP/N Output
0 (default)	xx	Disabled
1	00 (default)	CRU clock divided by 64
1	01	CMU clock divided by 66
1	10	CMU clock divided by 64
1	11	Test_Clock (factory use only)

3.4.11 External Phase Lock Loop

An external phase lock loop (PLL) circuit and low phase noise oscillator can be used to transform the VSC8486-11 IEEE 802.3ae compliant PMA block into a fully GR-253 jitter compliant PMA block in WAN operating mode. The following block diagram shows the required elements.

Figure 19 • Fully SONET Jitter Compliant Reference Clock Configuration

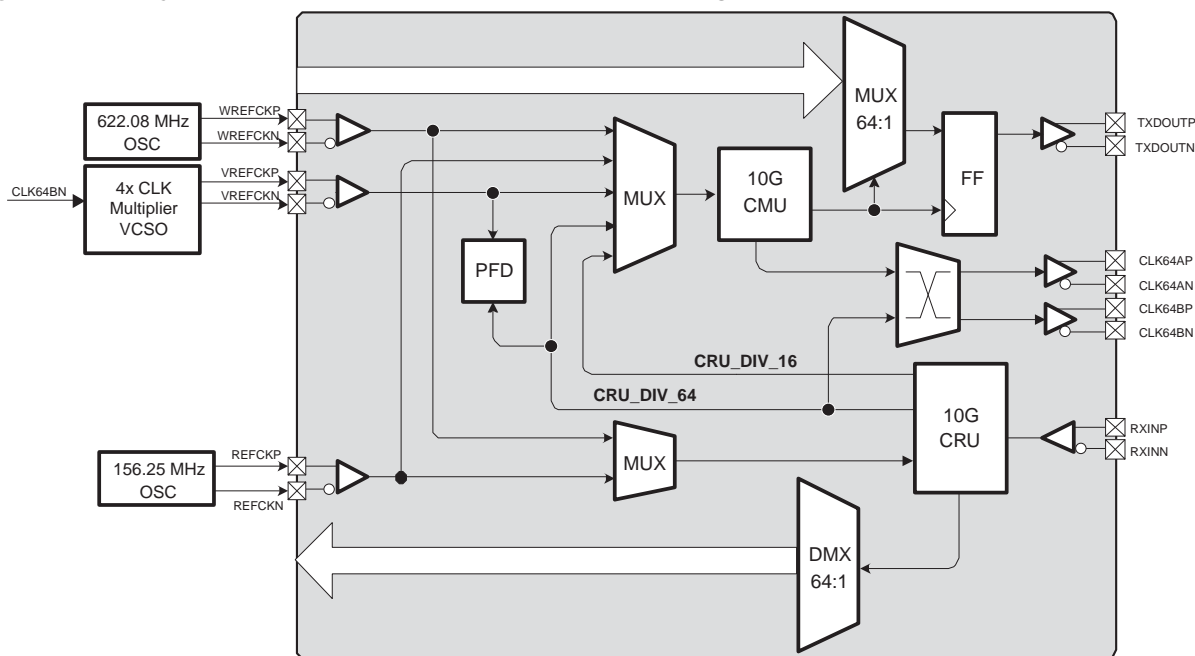

The preceding illustration shows the required elements to achieve SONET Terminal Equipment jitter compliance. Reference clocks must operate at the frequencies shown and each of the 622.08 MHz elements must have SONET quality performance specifications, which is normally based on surface acoustic wave (SAW).

3.4.12 High-Speed Serial Data Inputs

The incoming 10.3125 Gbps (LAN) or 10.51875 Gbps (SAN) or 9.953 Gbps (WAN) data is received by high-speed inputs (RXINP/N). The inputs are terminated internally with 50 Ω to RXINCM, as shown in the following illustration. This configuration also forms an impedance equivalent to 100 Ω across the differential pair to terminate the differential mode signal and a center-tapped virtual ground brought out as the RXINCM pin to absorb common mode noise. The receiver's input common mode voltage level is programmable by writing to VCM_ADJ (1×E701.11:6).

The inputs should be AC-coupled to allow for appropriate common mode voltage adjustments. The device can optionally be DC-coupled, which requires proper common mode.

The VSC8486-11 is designed to operate with XFI signaling based on nominal $100\ \Omega$ differential impedance and AC coupling. The AC coupling capacitors on the high-speed serial data inputs (RXINP/N) are expected to be in the XFP module. The RXINCM pin should be AC-coupled to ground through a $0.1\ \mu\text{F}$ capacitor to provide a low impedance AC return path for the $50\ \Omega$ termination.

The VSC8486-11 can also operate in a single-ended mode. The RXINCM pin should be AC-coupled to ground through a $0.1\ \mu\text{F}$ capacitor. The unused input should also be tied to a clean AC ground to prevent the RXINP signal from internally coupling through to RXINN and degrading input sensitivity. The total current through the $50\ \Omega$ resistor is limited to $25\ \text{mA}$; therefore, there should never be more than a $1\ \text{V}$ difference between RXINP and RXINCM, or between RXINN and RXINCM.

Figure 20 • CML XFI Data Receiver

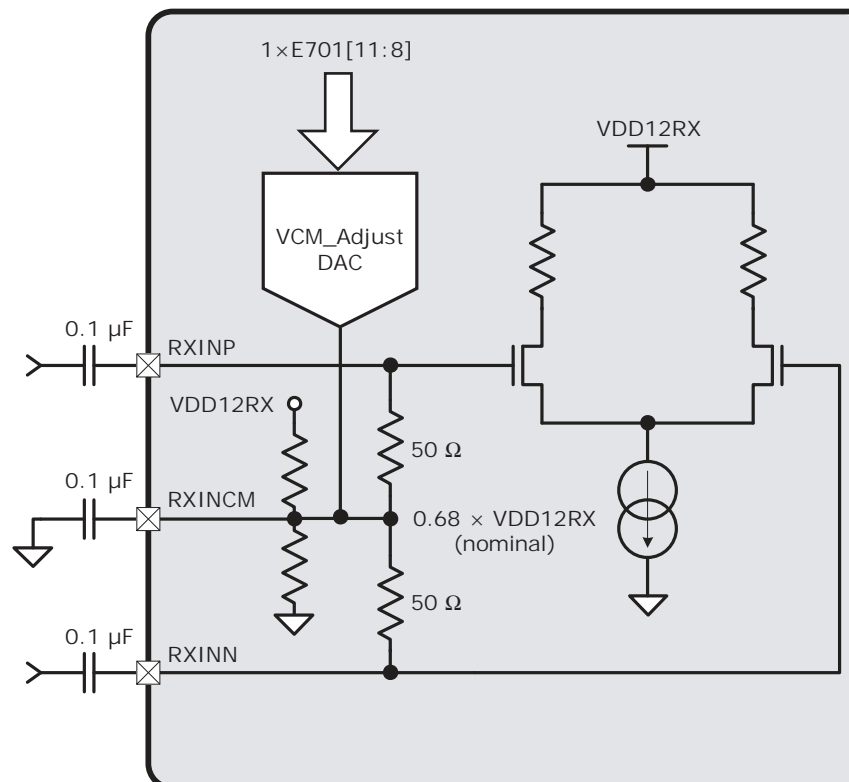

3.4.13 XFI Data Input Receiver Equalization

Incoming data on the RXINP/N inputs might contain a substantial amount of intersymbol interference (ISI) or deterministic jitter that reduces the ability of the receiver to recover data without errors. A programmable equalizer is provided in the input buffer to compensate for this deterministic jitter. This circuit is designed to effectively reduce the ISI commonly found in the copper PCB traces of an XFI-compliant channel, which can be as long as 12 inches. Typically for FR-4 materials, low frequencies are attenuated less than high frequencies as a result of the skin effect and dielectric losses. See the channel loss model as defined in the XFP multisource agreement.

The RXIP/N input equalizer includes a 2-bit control for peaking and decay to mitigate the effects of FR-4 losses. Overall receiver equalization response is adjusted by setting the four internal register bits, as shown in the following table.

Typical XFP host applications using less than 2 inches of FR-4 do not require modification of the default settings because the VSC8486-11 default setting includes some intrinsic peaking. For higher loss

tangent material and/or XFI channel physical trace lengths exceeding about 2 inches, changing the equalization settings to match those shown in the following table can offer the best performance.

Table 16 • Register 1x8002.14:11 RXINP/N Equalization Control

Peaking		Decay		Comment
Bit 14	Bit 13	Bit 12	Bit 11	
1	1	1	1	Default (less than 2 inches of FR-4).
1	1	0	0	Recommended for applications greater than 2 inches of FR-4. Recommendations are based on characterization data. Some applications can have optimal settings that diverge from the recommendations.

3.4.14 Loss of Signal

The Loss of Signal (LOS) circuitry utilizes peak-to-peak differential signal detection and selectable independent assert and deassert thresholds to produce an output LOS monitor proportional to the minimum usable signal present at the RXINP/N inputs. The following illustration shows the PMA LOS block diagram.

The LOS peak-to-peak voltage swing detection is determined by directly sensing the input signal at the input pins. The nominal LOS assert voltage is 50 mV. Calibration and adjustment of the LOS assert and deassert levels should be expected, because RXINP/N signals vary by application.

Figure 21 • PMA LOS Functional Block Diagram

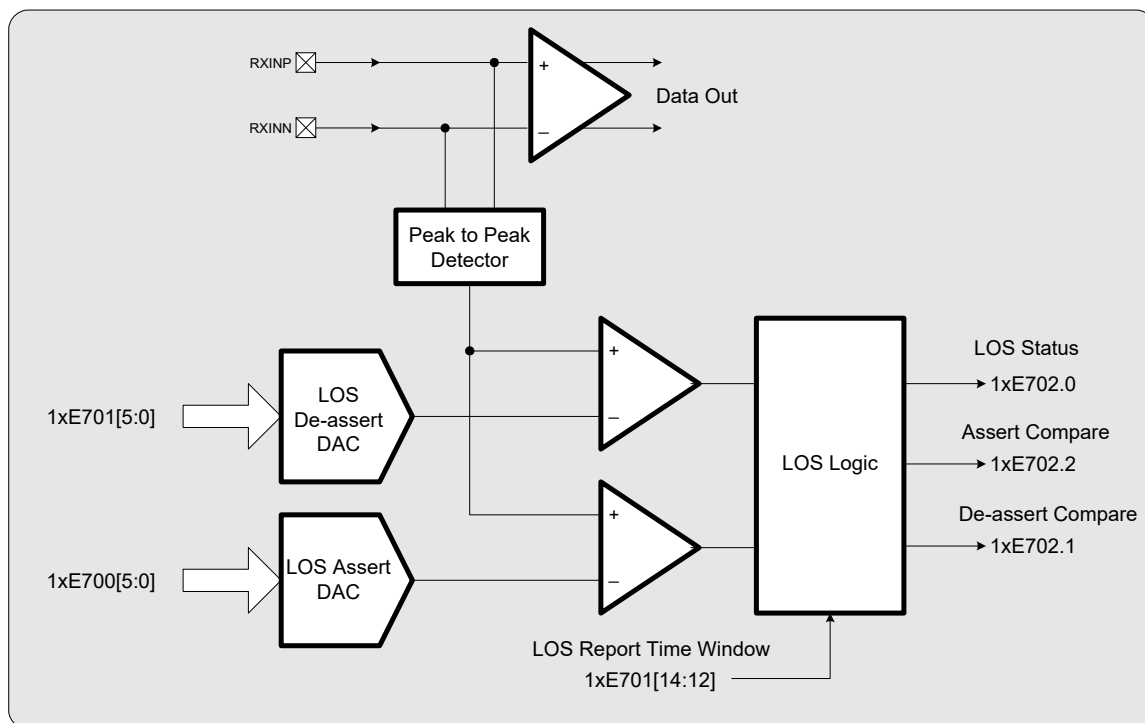

The following table summarizes register access for the VSC8486-11 PMA LOS functions.

Table 17 • PMA LOS Register Status and Control Summary

Register	Name	Function	Remarks
1×E702.0	LOS_STAT	If RXINP/N peak-to-peak signal falls below assert threshold, bit 0 = 1.	
1×E700.5:0	LOS_ASSERT_DAC (VA_OUT)	LOS assert threshold value. Default is minimum (000000).	Set the LOS assert voltage threshold. 000000: Less than 40 mV. 111111: Greater than 110 mV. All else: Reserved.
1×E701.5:0	LOS_DEASSERT_DAC (VDA_OUT)	LOS deassert threshold value. Default is minimum (000000).	Set the LOS deassert voltage threshold. 000000: Less than 40 mV. 111111: Greater than 110 mV. All else: Reserved.
1×E701.14:12	LOS_WIN	LOS reported or cleared when signal falls below assert threshold or remains above the deassert threshold within these approximate time interval limits.	LOS report range is 50 μ s to 100 μ s. LOS clear range is 125 μ s to 250 μ s. The same 3 bits simultaneously change LOS report and clear times from minimum (000) to maximum (111).
1×E702.1	LOS_DEASSERT_STAT	Bit 1 indicates deassert threshold crossed.	In normal operation, the deassert threshold is crossed when the peak-to-peak signal is increased following an LOS report.
1×E702.2	LOS_ASSERT_STAT	Bit 2 indicates assert threshold crossed.	In normal operation, the assert threshold is crossed when the peak-to-peak signal falls below a usable range. This range might require adjustment.
1×E701.15	LOS_PWR_DWN	Bit 15 set to 1 disables PMA LOS.	Default is LOS enabled, bit 15 = 0.

3.4.15 Loss of Optical Carrier

LOPC is an input pin for the VSC8486-11 that is normally connected to the XFP LOS output. Any change in level on the LOPC input asserts LOPC_PEND (2×EF04.11) until read. The current status of the LOPC input pin can be read using LOPC_STAT (2×EF03.11). The LOPC input can be active high or active low by setting the LOPC_POL_SEL (2×EC30.9) bit appropriately. The LOPCS_PEND bit can propagate an interrupt to either WIS_INTA or WIS_INTB based upon mask-enabled bits LOPC_MASKA (2×EF05.11) and LOPC_MASKB (2×EF06.11). For WIS applications, the LOPC input can be configured to initiate a line remote defect indication (RDI-L).

3.5 WAN Interface Sublayer

The WAN interface sublayer (WIS) is defined in IEEE Standard 802.3ae Clause 50. The VSC8486-11 WIS block is fully compliant with this specification. The VSC8486-11 offers additional controls, ports, and registers to allow integration into a wider array of SONET/SDH equipment. Clocking requirements are a critical component for SONET/SDH equipment as discussed in earlier sections.

In addition to the SONET/SDH features addressed by WIS as defined by IEEE, most SONET/SDH framers/mappers contain additional circuitry for implementing Operation, Administration, Maintenance and Provisioning (OAM&P). These framers/mappers also support special features to enable compatibility with legacy SONET/SDH solutions. Because the VSC8486-11 WIS leverages Microsemi's industry-leading framer/mapper technology it contains suitable features for standard SONET/SDH equipment. This includes the Transmit/Receive Overhead Serial Interfaces (TOSI/ROSI) commonly used for network customization and OAM&P, support for SONET/SDH errors not contained in the WIS standard, support for common legacy SONET/SDH implementations, and SONET/SDH jitter and timing quality.

3.5.1 Operation

The transmit portion of the WIS maps data from the PCS through the WIS service interface and to the SONET/SDH synchronous payload envelope (SPE). It then generates path, line, and section overhead octets, scrambles the frame, and transmits the frame to the PMA Service Interface. The receive portion of the WIS does the following: receives data from the PMA service interface; delineates octet and frame boundaries; descrambles the frame; processes section, line, and path overhead information that contain alarms and parity errors; interprets the pointer field; and extracts the payload for transmittal to the PCS through the WIS service interface. The WIS block diagram is shown in the following illustration.

Figure 22 • WIS Transmit and Receive Functions

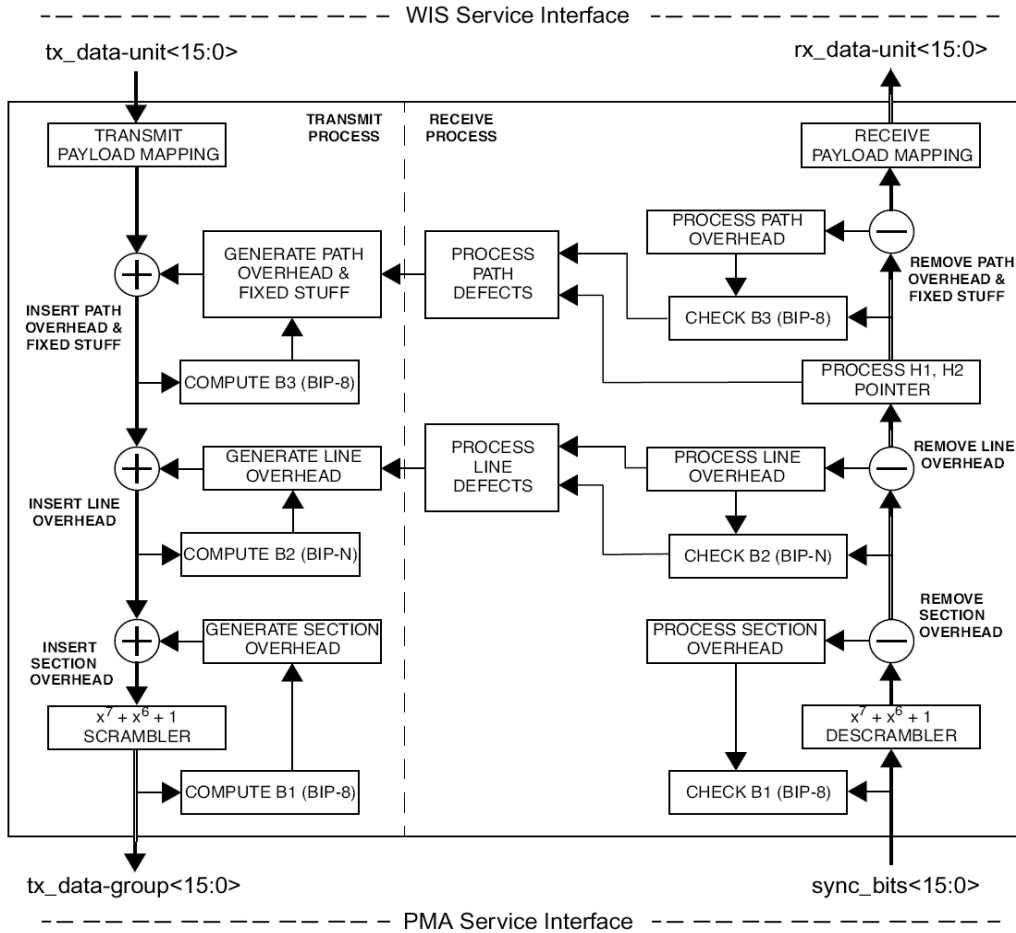

The WIS frame structure is illustrated in the following illustration.

Figure 23 • WIS Frame Structure

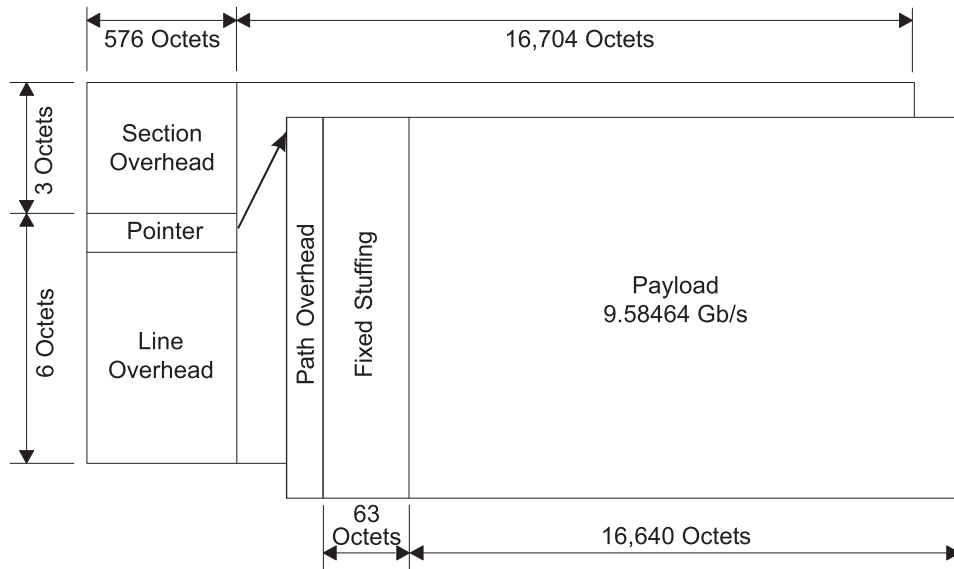

The positions of the section and line overhead octets within the WIS Frame are shown in the following illustration.

Figure 24 • STS-192c/STM-64 Section and Line Overhead Structure

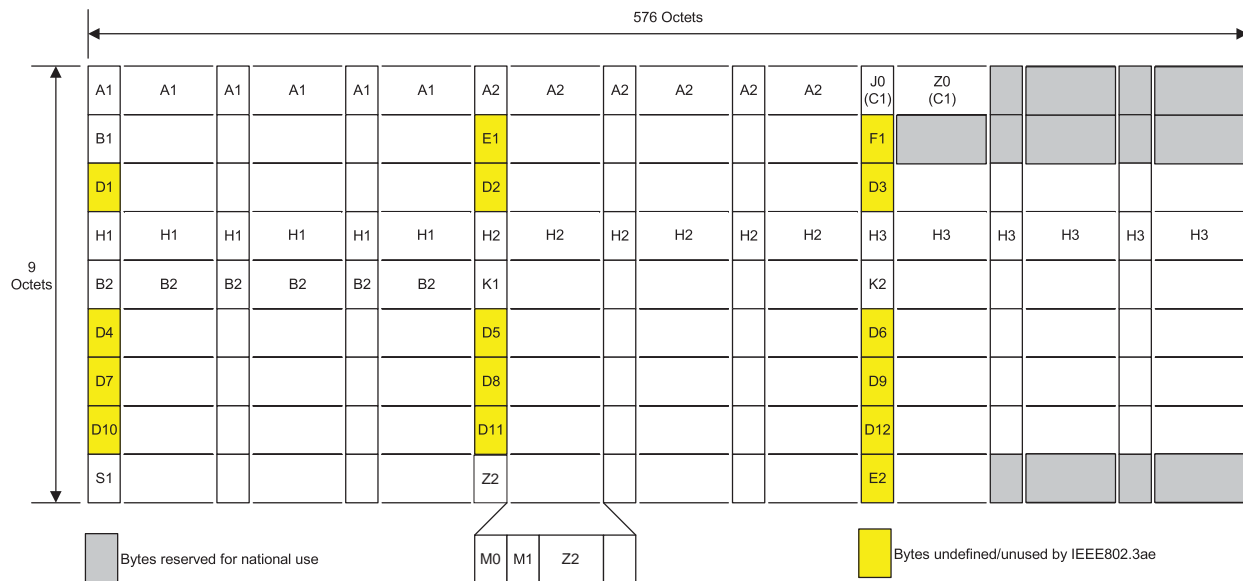

The path overhead octet positions are depicted in the following illustration.

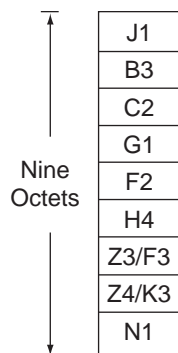
Figure 25 • Path Overhead Octets

3.5.2 Section Overhead

The section overhead portion of the SONET/SDH frame supports frame synchronization, a tandem connection monitor (TCM) known as the Section trace, a high-level parity check, and some OAM&P octets. The following table lists each of the octets including their function, specification, and related information.

The VSC8486-11 provides a mechanism to transmit a static value as programmed by the MDIO interface. However, by definition, MDIO is not fast enough to alter the octet on a frame-by-frame basis.

Table 18 • Section Overhead

Overhead Octet	Function	IEEE 802.3ae WIS Usage	Recommended Value	WIS Extension
A1	Frame alignment	Supported	0xF6	Register (2×E611) TOSI and ROSI access.
A2	Frame alignment	Supported	0x28	Register (2×E611) TOSI and ROSI access.
J0	Section trace	Specified value	See the discussion of J0 (Section Trace)	A 1-byte, 16-byte, or 64-byte trace message can be sent using registers 2×0040 to 2×0047, 2×E700, or 2×E800 to 2×E817 and received using registers 2×0048 to 2×004F, 2×EC20, and 2×E900 to 2×E917. TOSI and ROSI access.
Z0	Reserved for section growth	Unsupported	0xCC	Register 2×E612 TOSI and ROSI access.
B1	Section error monitoring (Section BIP-8)	Supported	Bit interleaved parity - 8 bits, as specified in T1.416	Using the TOSI, the B1 byte can be masked for test purposes. For each B1 mask bit that is cleared to 0 on the TOSI interface, the transmitted bit is left unchanged. For each B1 mask bit that is set to 1 on the TOSI interface, the transmitted bit is inverted. Using the ROSI, the B1 error locations can be extracted. Periodically latched counter (2×ECB0–2×ECB1) is available.
E1	Orderwire	Unsupported	0x00	Register 2×E612 TOSI and ROSI access.
F1	Section user channel	Unsupported	0x00	Register 2×E613 TOSI and ROSI access.
D1-D3	Section data communications channel (DCC)	Unsupported	0x00	Register 2×E613 to 2×E614 TOSI and ROSI access.

3.5.2.1 A1, A2 (Frame Alignment)

The SONET/SDH protocol is based upon a frame structure which is delineated by the framing octets, A1 and A2. The framing octets are defined to be 0xF6 and 0x28 respectively. In the transmit direction all 192 A1 octets are sourced from the TX_A1 (2xE611.15:8) register while the A2 octets are sourced from the TX_A2 (2xE611.7:0) register.

In the receive direction, the frame aligner monitors the input bus from the PMA and performs word alignment. The frame alignment architecture is composed of a primary and secondary state machine. The primary state diagram is shown in the following illustration and the variables for the primary state diagram are shown in the following table. The variables are reflected in registers EWIS_RX_FRM_CTRL1 (2xEC00) and EWIS_RX_FRM_CTRL2 (2xEC01) that can be alternately reconfigured. The selected frame alignment and synchronization pattern have implications on the tolerated input BER. The higher the input BER, the less likely the frame boundary can be found. The chances of finding the frame boundary are improved by reducing the number of A1/A2 bytes required to be detected (using a smaller pattern width). According to the WIS specification, the minimum for all parameters allows a signal with an error tolerance of 10^{-12} to be framed.

Figure 26 • Primary Synchronization State Diagram

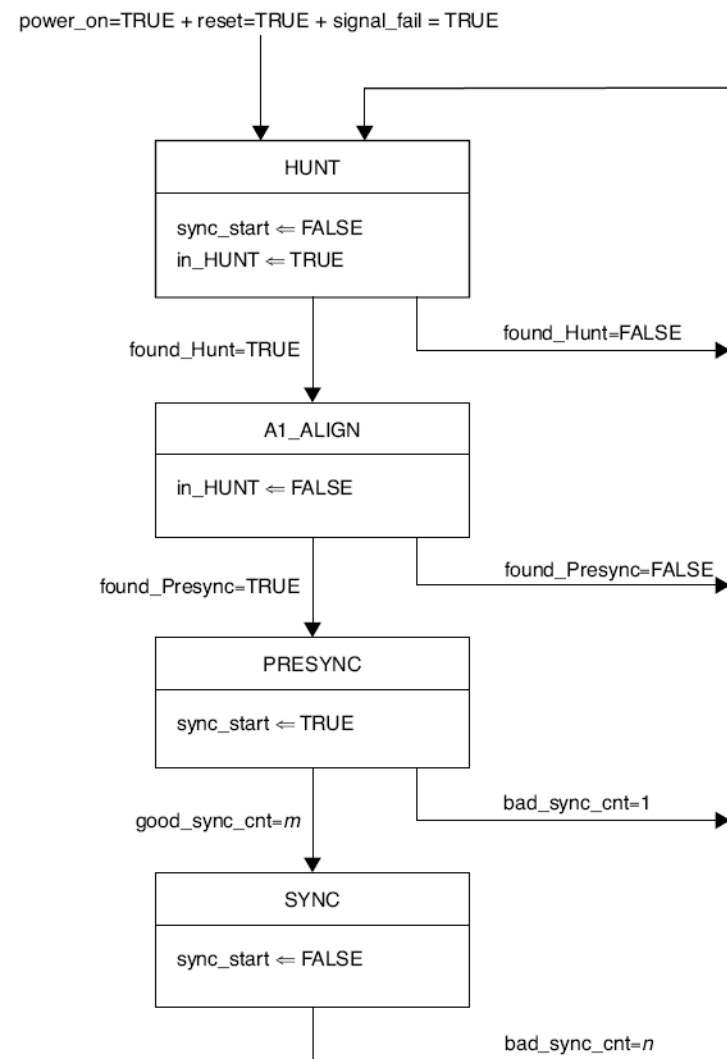
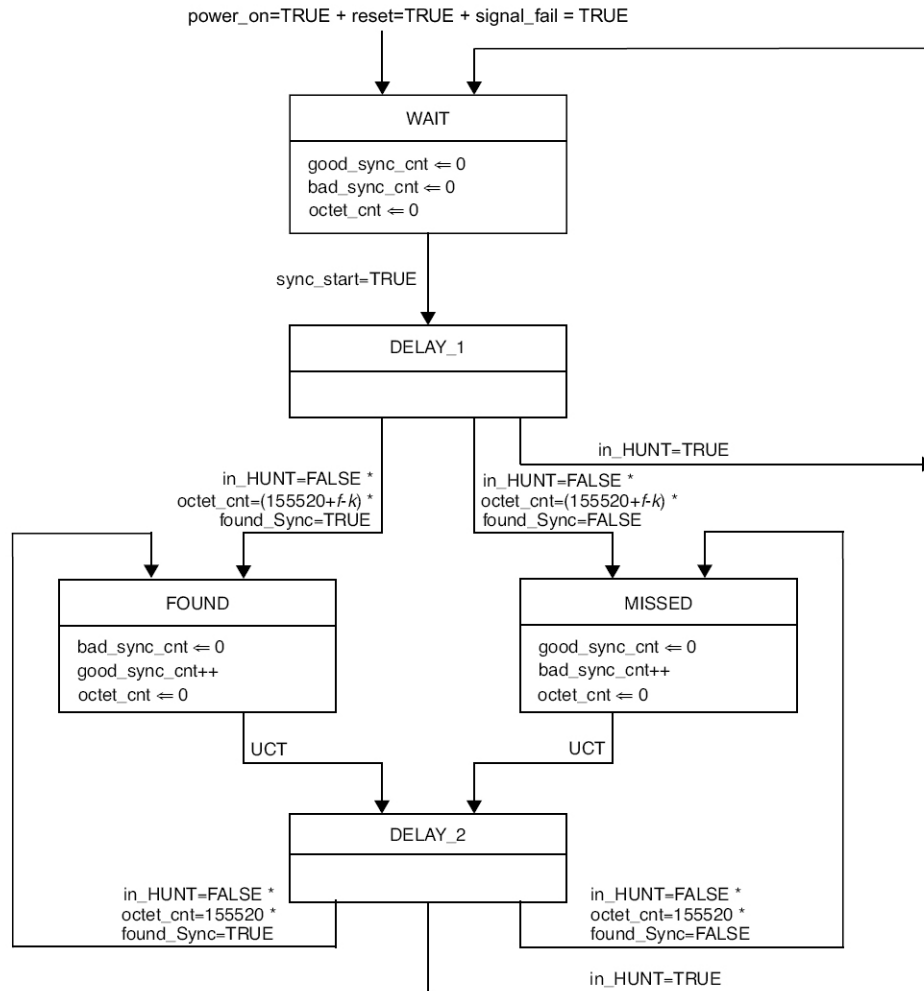

Figure 27 • Secondary Synchronization (Interval Pattern Search) State Diagram



The following table describes the variables for the primary state diagram.

Table 19 • Framing Parameter Description and Values

Name	Description	IEEE 802.3ae Parameter	IEEE 802.3ae Range	VSC8486-11 Range	VSC8486-11 Default
Sync_Pattern width	Sequence of f consecutive A1s followed immediately by a sequence of f consecutive A2s. If f = 2, Sync_Pattern is A1A1A2A2.	f	2 to 192	0 to 16. Exceptions: If f = 0, Sync_Pattern is A1 + 4 MSBs of A2. If f = 1, Sync_Pattern is A1A1A2.	2
Hunt_Pattern width	Sequence of i consecutive A1s.	i	1 to 192	1 to 16.	4

Table 19 • Framing Parameter Description and Values (continued)

Name	Description	IEEE 802.3ae Parameter	IEEE 802.3ae Range	VSC8486-11 Range	VSC8486-11 Default
Presync_Pattern A1 width	Presync_Pattern consists of a sequence of j consecutive A1s followed immediately by a sequence of k consecutive A2s.	j	16 to 190	1 to 16. If set to 0, behaves as if set to 1. If set to 17 to 31, behaves as if set to 16.	16
Presync_Pattern A2 width	Presync_Pattern consists of a sequence of j consecutive A1s followed immediately by a sequence of k consecutive A2s.	k	16 to 192	0 to 16. 0 means only 4 MSB of A2 are used. If set to 17 to 31, behaves as if set to 16.	16
SYNC state entry	Number of consecutive frame boundaries needed to be found after entering the PRESYNC state in order to enter the SYNC state.	m	4 to 8	1 to 15. If set to 0, behaves as if set to 1.	4
SYNC state exit	Number of consecutive frame boundary location errors detected before exiting the SYNC state.	n	1 to 8	1 to 15. If set to 0, behaves as if set to 1.	4

3.5.2.2 Loss of Signal (LOS)

The SONET/SDH Loss of Signal (LOS) alarm is tied to the PMA input receiver logic discussed in [Loss of Signal](#), page 26. The LOS (2×0021.6) alarm is a latch-high register; back-to-back reads provide both the event as well as status information. The LOS event also asserts the LOS_PEND (2×EF00.6) until read. This event can propagate an interrupt to either WIS_INTA or WIS_INTB based upon mask enable bits LOS_MASKA (2×EF01.6) and LOS_MASKB (2×EF02.6).

When the near end device experiences a LOS condition, it is possible to automatically transmit a remote defect indication (RDI-L) to the far end for notification purposes. The TXRDIL_ON_LOS (2×EE00.2), if asserted, overwrites the outgoing K2 bits with the RDI-L code. In the receive path, it is possible to force a AIS-L state (alarm assertion plus forcing the payload to an all ones state) upon a detection of an LOS condition. This is accomplished by asserting RXAISL_ON_LOS (2×EE00.5).

3.5.2.3 Loss of Optical Carrier (LOPC)

The input pin LOPC can be used by external optic components to directly assert the loss of optical power to the physical media device. Any change in level on the LOPC input asserts LOPC_PEND (2×EF04.11) until read. The current status of the LOPC input pin can be read using LOPC_STAT (2×EF03.11). The LOPC input can be active high or active low by setting the LOPC_POL_SEL (2×EC30.9) bit appropriately. The LOPCS_PEND bit can propagate an interrupt to either WIS_INTA or WIS_INTB based upon mask enable bits LOPC_MASKA (2×EF05.11) and LOPC_MASKB (2×EF06.11).

When the near end device experiences an LOPC condition, it is possible to automatically transmit a remote defect indication (RDI-L) to the far end to notify it of a problem. The TXRDIL_ON_LOPC (2×EE00.3), if asserted, overwrites the outgoing K2 bits with the RDI-L code. In the receive path, it is possible to force the receive framer into an LOF state, thereby squelching subsequent alarms and invalid payload data processing. This is accomplished by asserting RXLOF_ON_LOPC (2×EC30.8). Similar to the LOF condition forced upon an LOPC, the RXAISL_ON_LOPC (2×EE00.6) can force the AIS-L alarm assertion, plus force the payload to an all ones state to indicate to the PCS the lack of valid data, upon an LOPC condition.

3.5.2.4 Severely Errored Frame (SEF)

Upon reset, the VSC8486-11 enters the out of frame (OOF) state with both the severely errored frame (SEF) and loss of frame (LOF) alarms active. The SEF defect is terminated when the framer enters the SYNC state. The framer enters the SYNC state after SYNC_ENTRY_CNT (2×EC01.7:4) plus 1 consecutive frame boundaries are identified. A SEF defect state is declared when the framer enters the out-of-frame (OOF) state. The frame changes from the SYNC state to the OOF state when SYNC_EXIT_CNT (2×EC01.3:0) consecutive frames with errored frame alignment words are detected. SEF is indicated by asserting SEF (2×0021.11). This register latches high providing a combination of interrupt pending and status information within consecutive reads.

An additional bi-stable interrupt pending bit SEF_PEND (2×EF00.11) is provided which can propagate an interrupt to either WIS_INTA or WIS_INTB based upon mask enable bits SEF_MASKA (2×EF01.11) and SEF_MASKB (2×EF02.11).

3.5.2.5 Loss of Frame (LOF)

An LOF occurs when an out of frame state persists for an integrating period of LOF_T1 (2×EC02.11:6) frames. To provide for the case of intermittent OOFs, when not in the LOF state, the integrating timer is not reset to zero until an in-frame condition persists continuously for LOF_T2 (2×EC02.5:0) frames. Once in the LOF state, this state is left when the in-frame state persists continuously for LOF_T3 (2×EC03.6:1) frames. The LOF state is indicated by LOF (2×0021.7) being asserted. This register latches high, providing a combination of pending and status information over consecutive reads.

An additional bi-stable interrupt pending bit LOF_PEND (2×EF00.7) is provided which can propagate an interrupt to either WIS_INTA or WIS_INTB based upon mask enable bits LOF_MASKA (2×EF01.7) and LOF_MASKB (2×EF02.7).

When the near end device experiences an LOF condition, it might be required that the far end device be notified of the catastrophic condition. Transmitting an alarm indication signal (AIS-L) can accomplish this. If AISL_on_LOF (2×EE00.4) is asserted, the transmit path is preempted by the AIS-L pattern whenever an LOF alarm condition is asserted.

When the near end device experiences an LOF condition, it is possible to automatically transmit a remote defect indication (RDI-L) to the far end to notify it of a problem. The TXRDIL_ON_LOF (2×EE00.1), if asserted, overwrites the outgoing K2 bits with the RDI-L code. In the receive path, it is possible to force a AIS-L state (alarm assertion plus forcing the payload to an all ones state) upon a detection of an LOF condition. This is accomplished by asserting RXAISL_ON_LOF (2×EE00.4).

3.5.2.6 J0 (Section Trace)

The J0 octet often carries a repeating message called the Section Trace Message. The default transmitted message length is 16-octets whose contents are defined in J0_TXMSG (2×0040–2×0047). If no active message is being broadcast, a default Section Trace Message consisting of 15 octets of zeros and a header octet formatted according to Section 5 of ANSI T1.269-2000 shall be transmitted. The header octet for the 15-octets of zero would be 0×89.

The J0 octet in the receive direction by default is assumed to be carrying a 16-octet continuously repeating Section Trace Message. The message is extracted from the incoming WIS frames and stored in J0_RXMSG (2×0048–2×004F). The WIS receive process does not delineate the message boundaries, thus the message might appear rotated between new frame alignment events.

The VSC8486-11 supports two alternate message types, a single repeating octet and a 64-octet message. The message type can be independently selected for the transmit and receive direction. The transmit direction is configured using J0_TXLEN (2×E700.3:2) while J0_RXLEN (2×EC20.3:2) configures the receive path.

When the transmit direction is configured for a 64-octet message the first 16 octets are programmed in J0_TXMSG (2×0040–2×0047) while the 48 remaining octets are programmed in J0_TXMSG64 (2×E800–2×E817). Likewise, the first 16 octets of the receive message are stored in J0_RXMSG (2×0048–2×004F) while the other 48 octets are stored in J0_RXMSG64 (2×E900–2×E917). The receive message is updated every 125 μs with the recently received octet. Any persistency or message matching is expected to take place within the station manager.

3.5.2.7 Z0 (Reserved for Section Growth)

The WIS standard does not support the Z0 octet and requires transmission of 0×CC in the octet locations. A different Z0 value can be transmitted by configuring TX_Z0 (2×E612.15:8). The TX_Z0 default is 0×CC.

3.5.2.8 Scrambling/Descrambling

The transmit signal (except for row 1 of the section overhead) is scrambled according to the standards when SCR_EN (2×E600.12) is asserted, which is the default state. When deasserted, the scrambler is disabled.

The receive signal descrambler DESCR_EN (2×EC10.1) is enabled by default; however, by deasserting this bit the descrambler can be bypassed.

3.5.2.9 B1 (Section Error Monitoring)

The B1 octet is a bit interleaved parity-8 (BIP-8) code using even parity calculated over the previous STS-192c frame, post scrambling. The computed BIP-8 is placed in the following outgoing SONET frame before scrambling.

In the receive direction, the incoming frame is processed and a BIP-8 is calculated. The calculated value is then compared with the B1 value received in the following frame. The difference between the calculated and received octets are accumulated into B1_CNT (2×003C). This counter rolls over after the maximum count. This counter is cleared upon device reset.

The B1_ERR_CNT[1:0] (2×ECB0 to 2×ECB1) registers provide a count of the number of received B1 parity errors. This register is updated with the internal count value upon a PMTICK condition, after which the internal counter is reset to zero. When the counter is nonzero, the B1_NZ_PEND (2×EF04.7) event is asserted until read. A non-latch high version of this event, B1_NZ_STAT (2×EF03.7) is also available. This event can propagate an interrupt to either WIS_INTA or WIS_INTB based upon mask enable bits B1_ERR_MASKA (2×EF05.7) and B1_ERR_MASKB (2×EF06.7).

The B1_ERR_CNT can optionally be configured to increment on a block count basis, a maximum increment of 1 per errored frame regardless of the number of errors received. This mode is enabled by asserting B1_BLK (2×EC61.11)

3.5.2.10 E1 (Section Orderwire)

The WIS standard does not support the E1 octet and requires transmission of 0×00 in the octet location. A different E1 value can be transmitted by configuring TX_E1 (2×E612.7:0) whose default is 0×00.

3.5.2.11 F1 (Section User Channel)

The WIS standard does not support the F1 octet and requires transmission of 0×00 in the octet location. A different F1 value can be transmitted by configuring TX_F1 (2×E613.15:8) whose default is 0×00.

3.5.2.12 DCC-S (Section Data Communication Channel)

The WIS standard does not support the DCC-S octets and requires transmission of 0×00 in the octet locations. Different DCC-S values can be transmitted by configuring TX_D1 (2×E613.7:0), TX_D2 (2×E614.15:8), and TX_D3 (2×E614.7:0), all of which default to 0×00.

3.5.2.13 Reserved, National and Unused Octets

The VSC8486-11 transmits 0×00 for all Reserved, National, and unused overhead octets.

3.5.3 Line Overhead

The line overhead portion of the SONET/SDH frame supports pointer interpretation, a per channel parity check, protection switching information, synchronization status messaging, far end error reporting, and some OAM&P octets. The following table lists each of the octets including their function, specification, and related information.

The VSC8486-11 provides a mechanism to transmit a static value as programmed by the MDIO interface. However, by definition, MDIO is not fast enough to alter the octet on a frame-by-frame basis.

Table 20 • Line Overhead Octets

Overhead Octet	Function	IEEE 802.3ae WIS Usage	Recommended Value	WIS Extension
H1-H2	Pointer	Specified value	SONET mode: STS-1: 0×62, 0×0A STS-n: 0×93, 0×FF SDH mode: STS-1: 0×6A, 0×0A STS-n: 0×9B, 0×FF	Register 2×E615 to 2×E616 TOSI and ROSI access.
H3	Pointer action	Specified value	0×00	Register 2×E616 TOSI and ROSI access.
B2	Line error monitoring (line BIP-1536)	Supported	Bit interleave parity-8, as specified in T1.416	Using the TOSI, the B2 bytes can be masked for test purposes. For each B2 mask bit that is cleared to 0 on the TOSI interface, the transmitted bit is left unchanged. For each B2 mask bit that is set to 1 on the TOSI interface, the transmitted bit is inverted. Using the ROSI, the B2 error locations can be extracted. Periodically latched counter (2×ECB0–2×ECB1) is available.
K1, K2	Automatic protection switch (APS) channel and line remote defect identifier (RDI-L)	Specified value	For information about K2 coding, see Table 21 , page 38	Register 2×E617 to 2×E618 TOSI and ROSI access.
D4-D12	Line data communications channel (DCC)	Unsupported	0×00	Register 2×E619 to 2×E61E TOSI and ROSI access.
S1	Synchronization messaging	Unsupported	0×0F	Register 2×E61F TOSI and ROSI access.
Z1	Reserved for Line growth	Unsupported	0×00	Register 2×E61F TOSI and ROSI access.
M0/M1	STS-1/N line remote error indication (REI)	M0 unsupported, M1 supported	0×00/number of detected B2 errors in the receive path, as specified in T1.416	TOSI and ROSI access. The VSC8486-11 supports a mode that uses only M1 to back report REI-L (REI_MODE = 0) and another mode which uses both M0 and M1 to back report REI-L (REI_MODE = 1). For more information, see the following B2 text.
E2	Orderwire	Unsupported	0×00	Register 2×E620 TOSI and ROSI access.
Z2	Reserved for Line growth	Unsupported	0×00	Register 2×E620 TOSI and ROSI access.

3.5.3.1 B2 (Line Error Monitoring)

The B2 octet is a BIP-8 value calculated over each of the previous STS-1 channels excluding the section overhead and prescrambling. As the B2 octet is calculated on an STS-1 basis there are 192 B2 octets

within an STS-192/STM-64 frame. Each of the 192 calculated BIP-8 octets are then placed in the outgoing SONET/SDH frame.

In the receive direction, the incoming frame is processed, and a per STS-1 BIP-8 is calculated (excluding section overhead and after descrambling) and then compared to the B2 value in the following frame. Errors are accumulated into a 32-bit counter B2_CNT (2×0039–2×003A). This counter is nonsaturating and so rolls over after its maximum count. The counter is cleared only on device reset.

An additional 32-bit B2 error counter is provided at B2_ERR_CNT (2×ECB2–2×ECB3), which is a saturating counter and is latched and cleared based upon a PMTICK event. Errors are accumulated since the previous PMTICK event. When the counter is nonzero, the B2_NZ_PEND (2×EF04.6) event is asserted until read. A non-latch high version of this event B2_NZ_STAT (2×EF03.6) is also available. This event can propagate an interrupt to either WIS_INTA or WIS_INTB, based on mask enable bits B2_ERR_MASKA (2×EF05.6) and B2_ERR_MASKB (2×EF06.6).

The B2_ERR_CNT can optionally be configured to increment on a block count basis, a maximum increment of 1 per errored frame regardless of the number of errors received. This mode is enabled by asserting B2_BLK (2×EC61.10).

It is possible that two sets of B2 bytes (from two SONET/SDH frames) are received by the Rx WIS logic in a period of time when only one M0/M1 octet is transmitted. In this situation, one of the two B2 error counts delivered to the Tx WIS logic is discarded. This situation occurs when the receive data rate is faster than the transmit data rate. Similarly, when the transmit data rate is faster than the receive data rate, a B2 error count is not available for REI-L insertion into the M0/M1 octets of the transmitted SONET/SDH frame. A value of zero is transmitted in this case. This behavior is achieved by using a FIFO to transfer the detected B2 error count from the receive to transmit domains.

A FIFO overflow or underflow condition is not considered an error. Instead it is recovered from gracefully as described above. A FIFO overflow or underflow eventually occurs unless the transmit and receive interfaces are running at the same average data rate. Because the received and transmitted frames can differ by, at most, 40 ppm (± 20 ppm) and still meet the industry standards, this “slip” can happen no more often than once every 3.1 seconds.

3.5.3.2 K1, K2 (APS Channel and Line Remote Defect Identifier)

The K1 and K2 octets carry information regarding Automatic Protection Switching (APS) and Line Remote Defect Identifier (RDI-L). The K1 octet and the most significant five bits of the K2 octet contain the APS channel information. The transmitted values can be configured at TX_K1 (2×E617.7:0) and TX_K2 (2×E618.15:8). The default values of all zeros are compliant with the WIS standard.

The three least significant bits within the K2 octet carry the RDI-L encoding, as defined by section 7.4.1 of ANSI T1.416-1999 and as shown in the following table.

Table 21 • K2 Encodings

Indicator	K2 Value for Bits 6, 7, 8	Interpretation
RDI-L	110	Remote error indication. For the receive process, an RDI-L defect occurs after a programmable number of RDI-L signals are received in contiguous frames and is terminated when no RDI-L is received for the same number of contiguous frames. An RDI-L can be forced by asserting FRC_RX_RDIL (2×2×EC30.2). For the transmit process, the WIS standard does not indicate when or how to transmit RDI-L. VSC8486-11 provides the option of transmitting K2 by programming it through the TOSI, by programming it using the K2_TX MDIO register, or by programming it based on the contents of the K2_TX register with bits 6, 7, and 8 modified depending on the status of the following: LOPC, LOS, LOF, AIS-L and their associated transmit enable bits TXRDIL_ON_LOPC (2×EE00.3), TXRDIL_ON_LOS (2×EE00.2), TXRDIL_ON_LOF (2×EE00.1), and TXRDIL_ON_AISL (2×EE00.0).
AIS-L	111	Alarm indication signal (line). For the receive process, this is detected based on the settings of the K2 byte. When AIS-L is detected, the WIS link status is down and MDIO register 2×0021.4 is set high. This also contributes to errored second (ES) and severally errored second (SES) reports. For standard WIS operation, this is never transmitted.
Idle (normal)	000	Unless RDI-L exists, the standard WIS transmits idle.

Although the transmission of RDI-L is not explicitly defined within the WIS standard, the VSC8486-11 allows the automatic transmission of RDI-L upon the detection of LOPC, LOS, LOF, or AIS-L conditions. These features are enabled by asserting RDIL_ON_LOPC (2×EE00.3), RDIL_ON_LOS (2×EE00.2), RDIL_ON_LOF (2×EE00.1), and RDIL_ON_AISL (2×EE00.0).

The VSC8486-11 can force an RDI-L condition independent of the K2 transmit value by asserting FRC_RDIL (2×E600.2). Likewise, an AIS-L condition can be forced by asserting FRC_AISL (2×E600.1). If both conditions are forced, the AIS-L value is transmitted.

In the receive direction, the RDI-L alarm (K2[6:8] = 110, using SONET nomenclature) and the AIS-L alarm (K2[6:8] = 111, using SONET nomenclature) are not asserted until the condition persists for a programmable number of contiguous frames. This value is programmable at APS_THRES (2×EC30.7:4) and is typically set to values of 5 or 10.

The WIS standard defines RDIL (2×0021.5) and AISL (2×0021.4) as a read only latch-high register, so a read of a one in this register indicates that an error condition occurred since the last read. A second read of the register provides the current status of the event as to whether the alarm is currently asserted. RDIL_PEND (2×EF00.5) and AISL_PEND (2×EF00.4) assert whenever the RDI-L or AIS-L state changes (assert or deassert). These interrupts have associated mask enable bits, RDIL_MASK/AISL_MASK (2×EF01.5:4/2×EF02.5:4), which, if enabled, propagate an interrupt to the WIS_INTA/B pins.

For test purposes, the VSC8486-11 can induce an RDI-L condition in the receive direction independent of the received K2 value by asserting FRC_RX_RDIL (2×EC30.2). Likewise, an AIS-L condition can be forced in the receive direction by asserting FRC_RX_AISL (2×EC30.3).

3.5.3.3 AISFORCE Pin

When set high, the AISFORCE pin generates a near end AIS-L defect.

3.5.3.4 D4 to D12 (Line Data Communications Channel)

The WIS standard does not support Line Data Communications Channel (L-DCC) octets (D4-D12) and recommends transmitting 0×00 within these octets. The D4-D12 transmitted values can be programmed at (2×E619–2×E61E). The register defaults are all 0×00. The receive L-DCC octets are only accessible through the ROSI port.

3.5.3.5 M0 and M1 (STS-1/N Line Remote Error Indication)

The M0 and M1 octets are used for back reporting the number of B2 errors received, known as remote error indication (REI-L). The value in this octet comes from the B2 error FIFO, as discussed with the B2 octet. The WIS standard does not support the M0 octet and recommends transmitting 0×00 in place of the M0 octet. However, the WIS standard supports the M1 octet in accordance with T1.416.

Two methods for back-reporting exist and are controlled by G707_2000_REIL (2×EC40.12). Because a single frame can contain up to 1536 B2 errors while the M1 byte alone can only back report a maximum of 255 errors, a discrepancy exists. When G707_2000_REIL is deasserted, only the M1 byte is used and a maximum of 255 errors are back-reported. When G707_2000_REIL is asserted, two octets per frame are used for back reporting, the M1 octet and the M0 octet (not the first STS-1 octet, but the second STS-1 octet). In this mode, a total of 1536 errors can be back-reported per frame.

In the receive direction the VSC8486-11 detects and accumulate errors according to the G707_2000_REIL setting. The VSC8486-11 deviates from the G.707 standard by not interpreting REI-L values greater than 1536 as zero. The WIS standard defines a 32-bit REI-L counter REIL_CNT (2×0037–2×0038). This counter is nonsaturating and so rolls over after its maximum count. The counter is cleared only on device reset.

An additional 32-bit REI-L counter is provided at REIL_ERR_CNT (2×EC90–2×EC91) which is a saturating counter and is latched and cleared based upon a PMTICK event. Errors are accumulated since the previous PMTICK event. When the counter is nonzero, the REIL_NZ_PEND (2×EF04.2) event is asserted until read. A non-latch high version of this event REIL_NZ_STAT (2×EF03.2) is also available. This event can propagate an interrupt to either WIS_INTA or WIS_INTB based upon mask enable bits REIL_NZ_MASKA (2×EF05.2) and REIL_NZ_MASKB (2×EF06.2).

The REIL_ERR_CNT can optionally be configured to increment on a block count basis, a maximum increment of 1 per errored frame regardless of the number of errors received. This mode is enabled by asserting REIL_BLK (2×EC61.4).

3.5.3.6 S1 (Synchronization Messaging)

The S1 octet carries the synchronization status message and provides synchronization quality measures of the transmission link in the least significant 4 bits. The WIS standard does not support the S1 octet and requires the transmission of a 0×0F within the S1 octet. A value other than 0×0F can be programmed in TX_S1 (2×E61F).

3.5.3.7 Z1 and Z2 (Reserved for Line Growth)

The WIS standard does not support the Z1 or Z2 octets and requires the transmission of 0×00 in their locations. Different Z1 and Z2 values can be transmitted by programming the values at TX_Z1 (2×E61F) and TX_Z2 (2×E620) respectively.

3.5.3.8 E2 (Orderwire)

The WIS standard does not support the E2 octet and recommends transmitting 0×00 in place of the E2 octet. A value other than 0×00 can be transmitted by programming the intended value at TX_E1 (2×E620).

3.5.4 Pointer

The H1 and H2 octets are used as a pointer within the SONET/SDH frame to locate the beginning of the path overhead and the beginning of the synchronous payload envelope (SPE). Within SONET/SDH the SPE can begin anywhere within the payload area, however IEEE Standard 802.3ae specifies that a transmitted SPE must always be positioned solely within a single SONET/SDH frame. The constant pointer value of 522 decimal (0x20A) must be contained in the first channel's H1 and H2 octets. Together these conditions result in the H1 and H2 octets being 0x62 and 0x0A, respectively. These are the default values of TX_H1 (2xE615.7:0) and TX_H2 (2xE616.15:8). Programming these registers with alternate values does not alter the positioning of the SPE, but it might induce a loss of pointer (LOP-P) at the far end, or at least prevent the far end from extracting the proper payload. Furthermore, the WIS standard specifies the frame structure be a concatenated payload. For this reason, the H1 and H2 octets in channels 2 through 192 contain the concatenation indicator.

The VSC8486-11 supports forcing the loss of pointer (LOP-P) and path alarm indication signal (AIS-P) state.

The WIS standard specifies that a 0x00 be transmitted in the H3 octet. An alternate value can be transmitted by programming TX_H3 (2xE616.7:0).

The WIS specification does not limit the pointer position within the receive SONET/SDH frame to allow interoperability to other SONET/SDH equipment. In addition to supporting the required SONET pointer rules, the VSC8486-11 pointer interpreter optionally supports SDH pointers. This is selectable using the SDH_RX_MODE (2xEC40.11) bit. The differences between SONET and SDH modes are as follows:

- For SONET, the SS bits are not used and are ignored by the VSC8486-11 pointer interpreter. For SDH, these bits are set to 10 and are checked by the VSC8486-11 pointer interpreter to determine the pointer type.
- For SONET, all 192 bytes of H1 and H2 are checked by the pointer interpreter to determine the pointer type. For SDH, only the first 64 bytes (first AU-4 of an AU-4-64c) are checked.
- SONET and SDH have different increment/decrement rules. SONET uses '8 out of 10' GR-253-core objective rule, while SDH uses a majority detect rule.

The H1 and H2 octets combine to form a word with several fields as shown in [Figure 28](#), page 40.

3.5.4.1 Bit Designations Within Payload Pointer

The 'N' bits [15:12] carry a New Data Flag (NDF). This mechanism allows an arbitrary change in the location of the payload. NDF is indicated by at least three out of the four N bits matching the code '1001' (NDF enabled). Normal operation is indicated by three out of the four N bits matching the code '0110' (normal NDF).

The last ten bits of the pointer word ('D' bits and 'I' bits) carry the pointer value. The pointer value has a range from 0 to 782 that indicates the offset between the first byte after the H3 byte and the first byte of the SPE.

The SS bits are located in bits 11 and 10 and are unused in SONET mode. In SDH mode, these bits are compared with pattern '10', and the pointer is considered invalid if it does not match.

Because VSC8486-11 only supports concatenated frames, only the first pair of bytes (H1, H2) are called the primary pointer and have a normal format. The rest of the H1/H2 bytes contain the concatenation indication (CI). The format for the CI is NDF enabled with a pointer value of all ones.

Figure 28 • 16-bit Designations within Payload Pointer

H1								H2							
15	14	13	12	11	10	9	8	7	6	5	4	3	2	1	0
N	N	N	N	S	S	I	D	I	D	I	D	I	D	I	D

3.5.4.2 Pointer Types

The VSC8486-11 supports five different pointer types as described in the following table. A Normal Pointer indicates the current pointer, a New Data Flag indicates a new pointer location, and an AIS pointer indicates AIS. The Pointer Increment and Pointer Decrement mechanism adjusts the frequency offset between the frame overhead and SPE. A Pointer Increment is indicated by a Normal NDF that has

the currently accepted pointer with the 'D' bits inverted. A Pointer Decrement is indicated by a Normal NDF that has the currently accepted pointer with 'I' bits inverted.

Table 22 • H1/H2 Pointer Types

Pointer Type	<i>nnnn</i> Value	Pointer Value	SS bits
Normal	Three out of the four bits matching '0110'	0 to 782	Matching in SDH mode, ignored in SONET mode
New Data Flag (NDF)	Three out of the four bits matching '1001'	0 to 782	Matching in SDH mode, ignored in SONET mode
AIS Pointer	1111	1111 1111 11	11
Pointer Increment	Three out of the four bits matching '0110'	Current pointer with 'I' bits inverted.	Matching in SDH mode, ignored in SONET mode
Pointer Decrement	Three out of the four bits matching '0110'	Current pointer with 'D' bits inverted.	Matching in SDH mode, ignored in SONET mode

Table 23 • Concatenation Indication Types

Pointer Type	<i>nnnn</i> Value	Pointer Value	SS bits
Normal concatenation indication	Three out of the four bits matching '1001'	1111 1111 11	Matching in SDH mode, ignored in SONET mode
AIS concatenation indication	Pointer value, <i>nnnn</i> value, and SS bits are the same as the AIS pointer indication		
Invalid concatenation indication	Any other concatenation indication other than Normal CI or AIS CI indication		

3.5.4.3 Pointer Adjustment Rule

The VSC8486-11 pointer interpreter adjusts the current pointer value according to rules listed in Section 9.1.6 of ANSI T1.105-1995. In addition, the following rule is observed: no increment/decrement is accepted for at least three frames following an increment/decrement or NDF operation.

3.5.4.4 Pointer Increment/Decrement Majority Rules

In SONET mode, the pointer interpreter uses more restrictive GR-253-CORE objective rules, as follows:

- An increment is indicated by eight or more bits matching noninverted D bits and inverted I bits.
- A decrement is indicated by eight or more bits matching noninverted I bits and inverted D bits.

In SDH mode, the majority rules are:

- An increment is indicated by three or more inverted I bits and two or fewer inverted D bits.
- A decrement is indicated by three or more inverted D bits and two or fewer inverted I bits.
- If both, three or more D bits are inverted and three or more I bits are inverted, no action is taken.

3.5.4.5 Pointer Interpretation States

The pointer interpreter algorithm for state transitions can be modeled as a finite state machine with three states, as shown in the following illustration. The three states are Normal (NORM), Loss of pointer (LOP), and Alarm Indication State (AIS).

Figure 29 • Pointer Interpreter State Diagram

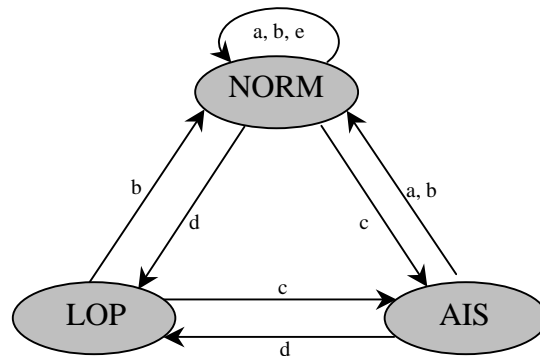

The conditions for transitions between these states are summarized in the following table.

Table 24 • Pointer Interpreter State Diagram Transitions

Transitions	States	Description	Required Persistence
a	NORM → NORM AIS → NORM	<H1><H2>=<EEEESSPP><PPPPPPPP>. NDF enabled with pointer in range (0 to 782). SS bit match (if enabled).	1 frame
b	NORM → NORM LOP → NORM AIS → NORM	<H1><H2>=<DDDDSSPP><PPPPPPPP>. NDF disabled (NORM pointer) with the same pointer value in range (0 to 782). SS bit match (if enabled).	3 frames
c	NORM → AIS LOP → AIS	<H1><H2>=<11111111><11111111>. AIS pointer (0xFFFF).	3 frames
d	NORM → LOP AIS → LOP	Anything other than transitions b and c or NDF enabled (transition a) or AIS pointer when not in AIS state or NORM pointer when not in NORM state or NORM pointer with pointer value not equal to current or increment/decrement or CONC pointer or SS bit mismatch (if comparison is enabled).	9 frames
e	Justification	Valid increment or decrement indication.	1 frame

3.5.4.6 Valid Pointer Definition for Interpreter State Diagram Transitions

During an AIS state, only an AIS pointer is a valid pointer. In NORM state, several definitions of “valid pointer” for purpose of LOP detection are possible according to GR-253-CORE. The VSC8486-11 follows the GR-253-CORE intended definition, but adds a single normal pointer that exactly matches the current ‘valid’ pointer value.

Any change in the AIS state is reflected in the alarm bit AISP (2×0021.1). This latch-high register reports both the event and status information in consecutive reads. The AISP_PEND (2×EF00.1) bit remains asserted until read. This event can propagate an interrupt to either WIS_INTA or WIS_INTB, based on mask enable bits AISP_MASKA (2×EF01.1) and AISP_MASKB (2×EF02.1).

Similarly, any change in the LOP state is reflected in the alarm bit LOPP (2×0021.0). This latch-high register reports both the event and status information in consecutive reads. The LOPP_PEND (2×EF00.0) bit remains asserted until read. This event can propagate an interrupt to either WIS_INTA or WIS_INTB, based upon the mask enable bits LOPP_MASKA (2×EF01.1) and LOPP_MASKB (2×EF02.1).

3.5.5 Path Overhead

The path overhead portion of the SONET/SDH frame supports an end-to-end trace identifier, a payload parity check, a payload type indicator, a status indicator, and a user channel. The following table lists each of the octets, including their function.

Note: The VSC8486-11 device provides a mechanism to transmit a static value as programmed by the MDIO interface. However, by definition, MDIO is not fast enough to alter the octet on a frame-by-frame basis. Extended WIS support TOSI and ROSI do not work for path overhead.

Table 25 • STS Path Overhead Octets

Overhead Octet	Function	IEEE 802.3ae WIS Usage	Recommended Value	WIS Extension
J1	Path trace message	Specified value	See the following discussion of J1 (overhead octet)	A 1-, 16-, or 64-byte trace message can be sent using registers (2×0027–2×002E, 2×E700, 2×EA00–2×EA17) and received using registers (2×002F–2×0036, 2×EC20, 2×EB00–2×EB17).
B3	Path error monitoring (path BIP-8)	Supported	Bit interleaved parity - 8 bits, as specified in T1.416	Both SONET and SDH mode B3 calculation is supported.
C2	Path signal label	Specified value	0×1A	Register (2×E615). Supports persistency and mismatch detection (2×EC40).
G1	Path status	Supported	As specified in T1.416	Ability to select between RDI-P and ERDI-P formats.
F2	Path user channel	Unsupported	0×00	Register (2×E618).
H4	Multiframe indicator	Unsupported	0×00	Register (2×E61A).
Z3-Z4	Reserved for path growth	Unsupported	0×00	Register (2×E61C, 2×E61E).
N1	Tandem connection maintenance and path data channel	Unsupported	0×00	Register (2×E621).

3.5.5.1 J1 (Overhead Octet)

By default, the J1 transmitted octet contains a 16-octet repeating path trace message whose contents are defined in J1_TXMSG (2×0027–2×002E). If no active message is being broadcast, a default path trace message is transmitted, consisting of 15 octets of zeros and a header octet formatted according to Section 5 of ANSI T1.269-2000. The header octet for the 15-octets of zero would be 0×89. The default

values of J1_TXMSG (2×0027–2×002E) do not contain the 0×89 value of the header octet, thus software must write this value.

The J1 octet in the receive direction by default is assumed to be carrying a 16-octet continuously repeating path trace message. The message is extracted from the incoming WIS frames and presented in J1_RXMSG (2×002F–2×0036). The WIS receive process does not delineate the message boundaries, thus the message might appear rotated between new frame alignment events.

The VSC8486-11 supports two alternate message types, a single repeating octet and a 64-octet message. The message type can be independently selected for the transmit and receive direction. The transmit direction is configured using J1_TXLEN (2×E700.1:0) while J1_RXLEN (2×EC20.1:0) configures the receive path.

When the transmit direction is configured for a 64-octet message, the first 16 octets are programmed in J1_TXMSG (2×0027–2×002E) while the 48 remaining octets are programmed in J1_TXMSG64 (2×EA00–2×EA17). Likewise, the first 16-octets of the receive message are stored in J1_RXMSG (2×002F–2×0036), while the other 48 octets are stored in J1_RXMSG64 (2×EB00–2×EB17). The receive message is updated every 125 μs with the recently received octet. Any persistence or message matching is expected to take place within the station manager.

3.5.5.2 B3 (STS Path Error Monitoring)

The B3 octet is a bit interleaved parity-8 (BIP-8) code, using even parity, calculated over the previous STS-192c SPE before scrambling. The computed BIP-8 is placed in the B3 byte of the following frame before scrambling.

In the receive direction, the incoming frame is processed and a B3 octet is calculated over the received frame. The calculated value is then compared with the B3 value received in the following frame. The difference between the calculated and received octets are accumulated in block (maximum increment of 1 per errored frame) fashion into a B3 error register, B3_CNT (2×003B). This counter is nonsaturating and so rolls over. The counter is cleared upon a device reset.

An additional 32-bit B3 error counter is provided at B3_ERR_CNT (2×ECB4–2×ECB5) which is a saturating counter and is latched and cleared based upon a PMTICK event. Errors are accumulated starting from the previous PMTICK event. When the counter is nonzero, the B3_NZ_PEND (2×EF04.5) event is asserted until read. A non-latch high version of this event B3_NZ_STAT (2×EF03.5) is also available. This event can propagate an interrupt to either WIS_INTA or WIS_INTB, based on the mask enable bits B3_ERR_MASKA (2×EF05.5) and B3_ERR_MASKB (2×EF06.5).

The B3_ERR_CNT can optionally be configured to increment on a block count basis, a maximum increment of 1 per errored frame regardless of the number of errors received. The B3_BLK (2×EC61.9) control bit, if asserted, places the B3_ERR_CNT counter in block increment mode.

It is possible that two sets of B3 bytes (from two SONET/SDH frames) are received by the Rx WIS logic in a period of time when only one G1 octet is transmitted. In this situation, one of the two B3 error counts delivered to the Tx WIS logic is discarded. This situation occurs when the receive data rate is faster than the transmit data rate. Similarly, when the transmit data rate is faster than the receive data rate, a B3 error count is not available for REI-P insertion into the G1 octets of the transmitted SONET/SDH frame. A value of zero is transmitted in this case. This behavior is achieved by using a FIFO to transfer the detected B3 error count from the receive to transmit domains.

A FIFO overflow or underflow condition is not considered an error. Instead it is recovered from gracefully as described above. A FIFO overflow or underflow eventually occurs, unless the transmit and receive interfaces are running at the same average data rate. Because the received and transmitted frames can differ by, at most, 40 ppm (±20 ppm) and still meet the industry standards, this “slip” can happen no more often than once every 3.1 seconds.

3.5.5.3 C2 (STS Path Signal Label and Path Label Mismatch)

The C2 octet contains a value intended to describe the type of payload carried within the SONET/SDH frame. The WIS standard calls for a 0×1A to be transmitted. This is the default value of TX_C2 (2×EC15).

As specified in T1.416, a path label mismatch (PLM-P) (2×0021.2) event occurs when the C2 octet in five consecutive frames contain a value other than the expected one. The expected value is set in C2_EXP (2×EC40.7:0), whose default value 0×1A is compliant with the WIS standard.

Whenever a value of 0×00 is accepted (received for five or more consecutive frames) the unequipped path pending, UNEQ_PEND (2×EF04.10), event is asserted until read. A non-latch high version of this event UNEQ_STAT (2×EF03.10) is also available. This event can propagate an interrupt to either WIS_INTA or WIS_INTB, based on the mask enable bits UNEQ_MASKA (2×EF05.10) and UNEQ_MASKB (2×EF06.10).

If the accepted value is not an unequipped label (0×00) and it differs from the programmed expected value, C2_EXP, then a path label mismatch, PLMP (2×0021.2), is asserted. Similarly the PLM_PEND (2×EF00.2) event is asserted until read. This event can propagate an interrupt to either WIS_INTA or WIS_INTB, based on the mask enable bits PLM_MASKA (2×EF01.2) and PLM_MASKB (2×EF02.2).

Although PLM-P is not a path level defect, it does cause a change in the setting of one of the ERDI-P codes, as described in Table 26, page 46.

3.5.5.4 G1 (Remote Path Error Indication)

The most significant four bits of the G1 octet is used for back reporting the number of B3 block errors received at the near end. This is typically known as path remote error indication (REI-P). The value in this octet comes from the B3 error FIFO, as discussed with the B3 octet. The WIS standard defines a 16-bit REI-P counter REIP_CNT (2×0025). The WIS standard defines this counter to operate as a block counter as opposed to an individual errored bit counter. This counter is nonsaturating and so rolls over after its maximum count. The counter does not clear upon a read, but instead only upon reset as defined in the WIS specification. When the counter is nonzero, the REIP_WISNZ_PEND (2×EF04.3) event is asserted until read. A non-latch high version of this event REIP_WISNZ_STAT (2×EF03.3) is also available. This event can propagate an interrupt to either WIS_INTA or WIS_INTB, based on the mask enable bits REIP_WISNZ_MASKA (2×EF05.3) and REIP_WISNZ_MASKB (2×EF06.3), respectively.

An additional 32-bit REI-P counter is provided at REIP_ERR_CNT (2×EC80–2×EC81) which is a saturating counter and is latched and cleared based upon a PMTICK event. Errors are accumulated since the previous PMTICK event. When the counter is nonzero, the REIP_EWISNZ_PEND (2×EF04.1) event is asserted until read. A non-latch high version of this event REIP_EWISNZ_STAT (2×EF03.1) is also available. This event can propagate an interrupt to either WIS_INTA or WIS_INTB, based on the mask enable bits REIP_EWISNZ_MASKA (2×EF05.1) and REIP_EWISNZ_MASKB (2×EF06.1), respectively.

The REIP_ERR_CNT can optionally be configured to increment on a block count basis, a maximum increment of 1 per errored frame regardless of the number of errors received. This mode is enabled by asserting REIP_BLK (2×EC61.5).

3.5.5.5 G1 (Path Status)

In addition to back-reporting the far end B3 BIP-8 error count, the G1 octet carries status information from the far end device known as path remote defect indicator (RDI-P). T1.416 allows either support of 1-bit RDI-P or 3-bit ERDI-P, but indicates ERDI-P is preferred. VSC8486-11 supports both modes and can be independently configured for the Rx and Tx directions by configuring RX_G1_MODE (2×EC40.8) and TX_G1_MODE (2×E600.10). ERDI-P is the default for both directions.

The different structures for this octet are shown in the following illustrations.

Figure 30 • Path Status (G1) Byte for ERDI_RDIN = 0

G1 REI (B3)				RDI-P	Reserved		Spare
1	2	3	4	5	6	7	8
Remote Error Indicator count from B3 (0-8 value)				Remote Defect Indicator	Set to 00 by transmitter		Ignored by receiver

Figure 31 • Path Status (G1) Byte for ERDI_RDIN = 1

G1 REI (B3)				ERDI-P			Spare
1	2	3	4	5	6	7	8
Remote Error Indicator count from B3 (0-8 value)				Enhanced Remote Defect Indicator (see following table)			Ignored by receiver

Enhanced RDI is defined for SONET-based systems as listed in GR-253-CORE (Issue 3), reproduced here in the following table, and as a possible enhancement of SDH-based systems (G.707/Y.1322 (10/2000) Appendix VII (not an integral part of that recommendation)).

Table 26 • RDI-P and ERDI-P Bit Settings and Interpretation

G1 Bits 5, 6, and 7	Priority of ERDI-P Codes	Trigger	Interpretation
000/011	Not applicable	No defects.	No RDI-P defect
100/111	Not applicable	Path alarm indication signal (AIS-P). The remote device sends all ones for H1, H2, H3, and the entire STS SPE. Path loss of pointer (LOP-P).	One-bit RDI-P defect
001	4	No defects.	No ERDI-P defect
010	3	Path label mismatch (PLM-P). Path loss of code group delineation (LCD-P).	ERDI-P payload defect
101	1	Path alarm indication signal (AIS-P). The remote device sends all ones for H1, H2, H3 and entire STS SPE. Path loss of pointer (LOP-P).	ERDI-P server defect
110	2	Path unequipped (UNEQ-P). The received C2 byte is 0x00. Path trace identifier mismatch (TIM-P). This error is not automatically generated, but can be forced using MDIO.	ERDI-P connectivity defect

In the receive direction, with RX_G1_MODE (2×EC40.8) = 0, an RDI-P defect is the occurrence of the RDI-P signal in 10 contiguous frames. An RDI-P defect terminates when no RDI-P signal is detected in 10 contiguous frames. An RDI-P event asserts FERDIP_PEND (2×EF04.8) until read. A non-latch high version of the far-end RDI-P status can be found in FERDIP_STAT (2×EF03.8). This event can propagate an interrupt to either WIS_INTA or WIS_INTB, based on the mask enable bits FERDIP_MASKA (2×EF05.8) and FERDIP_MASKB (2×EF06.8).

When RX_G1_MODE (2×EC40.8) = 1, an ERDI-P defect is the occurrence of any one of three ERDI-P signals in 10 contiguous frames. An ERDI-P defect terminates when no ERDI-P signal is detected in 10 contiguous frames.

The “010” code triggers the latch high register bit FE_PLM-P_LCD-P (2×0021.10). It also asserts FE_PLM-P_LCD-P_PEND (2×EF00.10) until read. This event can propagate an interrupt to either WIS_INTA or WIS_INTB, based on the mask enable bits FE_PLM-P_LCD-P_MASKA (2×EF01.10) and FE_PLM-P_LCD-P_MASKB (2×EF02.10), respectively.

The “101” code triggers the latch high register bit FE_AIS-P_LOP-P (2×0021.9). It also asserts FE_AIS-P_LOP-P_PEND (2×EF00.9) until read. This event can propagate an interrupt to either WIS_INTA or WIS_INTB, based on the mask enable bits FE_AIS-P_LOP-P_MASKA (2×EF01.9) and FE_AIS-P_LOP-P_MASKB (2×EF02.9), respectively.

The “110” code asserts the FE_UNEQ-P_PEND (2×EF04.9) until read. A non-latch-high version of this register FE_UNEQ_STAT (2×EF03.9) is also available. This event can propagate an interrupt to either WIS_INTA or WIS_INTB, based on the mask enable bits FE_UNEQ-P_MASKA (2×EF05.9) and FE_UNEQ-P_MASKB (2×EF06.9), respectively.

3.5.5.6 F2 (Path User Channel)

The WIS standard does not support the F2 octet and recommends transmitting 0x00 in place of the F2 octet. A value other than 0x00 can be transmitted by programming the intended value at TX_F2 (2xE618).

3.5.5.7 H4 (Multiframe Indicator)

The WIS standard does not support the H4 multiframe octet and recommends transmitting 0x00 in place of the H4 octet. A value other than 0x00 can be transmitted by programming the intended value at TX_H4 (2xE61A).

3.5.5.8 Z3-Z4 (Reserved for Path Growth)

The WIS standard does not support the Z3-Z4 octets and recommends transmitting 0x00 in their place. A value other than 0x00 can be transmitted by programming the intended value at TX_Z3 (2xE61C) and TX_Z4 (2xE61E) respectively.

3.5.5.9 N1 (Tandem Connection Maintenance/Path Data Channel)

The WIS standard does not support the N1 octet and recommends transmitting 0x00 in place of the N1 octet. A value other than 0x00 can be transmitted by programming the intended value at TX_N1 (2xE621).

3.5.5.10 Loss of Code Group Delineation

After the overhead is stripped, the payload is passed to the PCS. If the PCS block loses synchronization and cannot delineate valid code groups, the PCS passes a loss of code group delineation (LCD-P) alarm to the WIS. This alarm triggers the latch high register bit LCD-P (2x0021.3). It also asserts LCD-P_PEND (2xEF00.3) until read. This event can propagate an interrupt to either WIS_INTA or WIS_INTB, based on the mask enable bits LCD-P_MASKA (2xEF01.3) and LCD-P_MASKB (2xEF02.3), respectively.

The WIS specification calls for a LCD-P defect persisting continuously for more than 3 ms to be back reported to the far end. Upon device reset a LCD-P shall also be back reported until the PCS signals that valid code groups are being delineated. The LCD-P defect deasserts (and is not back reported) after the condition is absent continuously for at least 1 ms.

3.5.6 Reading Statistical Counters

The VSC8486-11 contains several counters that can be read using the MDIO interface. For each error count, there are two sets of counters. The first set is the standard WIS counter implemented according to IEEE Standard 802.3ae, and the second set is for statistical counts using PMTICK.

To read the IEEE Standard 802.3ae counters, the Station Manager must read the most significant register of the 32-bit counter first. This read action latches the internal error counter value into the MDIO readable registers. A subsequent read of the least significant register does not latch new values, but returns the value latched at the time of the most significant register read.

Since the IEEE Standard 802.3ae counters are independently latched it can be difficult to get a clear picture of the timeframes in which errors were received. The PMTICK counters are all latched together, thereby providing a complete snapshot in time. When PMTICK is asserted the internal error counter values are copied into their associated registers and the internal counters are reset.

There are two methods of asserting PMTICK.

- The Station Manager can asynchronously assert PMTICK_FRC (2xEC60.0) to latch the values at a given time, regardless of the PMTICK_ENA (2xEC60.2) setting.
- The VSC8486-11 can be configured to latch and clear the statistical counters at a periodic interval as determined by the timer (count) value in PMTICK_DUR (2xEC60.15:3). In this mode the PMTICK_SRC (2xEC60.1) must be configured for internal mode and the PMTICK_ENA (2xEC60.2) bit must be asserted. The receive path clock is used to drive the PMTICK counter, thus the periodicity of the timer can vary during times of loss of lock and loss of frame.

Regardless of PMTICK_SRC (2xEC60.1), when the PMTICK event occurs the PMTICK_PEND (2xEF04.14) is asserted until read. This event can propagate an interrupt to either WIS_INTA or

WIS_INTB, based on the mask enable bits PMTICK_MASKA (2×EF05.14) and PMTICK_MASKB (2×EF06.14), respectively.

Given the size of the error counters and the maximum allowable error counts per frame, care must be taken in the frequency of polling the registers to ensure accurate values. All PMTICK counters saturate at their maximum values.

Table 27 • PMTICK Counters

Counter Name	Description	Registers	Maximum Increase Count Per Frame	Maximum Increase Count Per Second	Time Until Overflow
B1_ERROR_CNT	B1 section error count	B1_ERROR_CNT1, B1_ERROR_CNT0	8	64,000	67,109
B2_ERROR_CNT	B2 line error count	B2_ERROR_CNT1, B2_ERROR_CNT0	1536	12,288,000	350
B3_ERROR_CNT	B3 path error count	B3_ERROR_CNT1, B3_ERROR_CNT0	8	64,000	67,109
FAR_B3_ERROR_CNT	Far end B3 path error count	FAR_B3_ERROR_CNT1, FAR_B3_ERROR_CNT0	8	64,000	67,109
FAR_B2_ERROR_CNT	Far end B2 line error count	FAR_B2_ERROR_CNT1, FAR_B2_ERROR_CNT0	1536	12,288,000	350

Both individual and block mode accumulation of B1, B2, and B3 error indications are supported and selectable using the control bits B1_BLK, B2_BLK, and B3_BLK. In individual accumulation mode, '0', the counter is incremented for each bit mismatch between the calculated B1, B2, and/or B3 error and the extracted B1, B2, and/or B3. In block accumulation mode, '1', the counter is incremented only once for any nonzero number of bit mismatches between the calculated B1, B2, and/or B3 and the extracted B1, B2, and/or B3 (maximum of 1 error per frame).

3.5.7 Defects and Anomalies

All defects and anomalies listed in the following table can be forced and masked by the user. The VSC8486-11 does not automatically generate TIM-P, but does support forcing defects using MDIO.

Table 28 • Defects and Anomalies

Defect or Anomaly	Description	Type	Force Bit	Status Bit
Far end PLM-P or LCD-P	These two errors are indistinguishable when reported by the far end through the G1 octet (ERDI-P), because the far end reports both PLM-P and LCD-P with the same error code.	Far end defect	2×EC31.10	2×0021.10
Far end AIS-P or LOP-P	These two errors are indistinguishable when reported by the far end through the G1 octet (ERDI-P), because the far end reports both AIS-P and LOP-P with the same error code.	Far end defect	2×EC31.12	2×0021.9

Table 28 • Defects and Anomalies (continued)

Defect or Anomaly	Description	Type	Force Bit	Status Bit
PLM-P	Path label mismatch. The detection and reporting of the PLM-P defect follows section 7.5 of ANSI T1.416-1999.	Near end defect; propagated to PCS	2×EC31.14	2×0021.2
AIS-L	Generated on LOPC, LOS, LOF, if enabled by AISL_ON_LOPC (2×EE00.6), AISL_ON_LOS (2×EE00.5), AISL_ON_LOF (2×EE00.4), or when forced by user.	Near end defect	The AIS-L defect is only processed and reported by the WIS Receive process; it is never transmitted by the WIS Transmit process according to IEEE 802.3ae.	2×EC30.3/2 ×0021.4
AIS-P	Path alarm indication signal.	Near end defect; propagated to PCS	2×EC30.1	2×0021.1
LOP-P	Path loss of pointer. Nine consecutive invalid pointers result in loss of pointer detection. See Figure 29 , page 42 for pointer state machine.	Near end defect; propagated to PCS	2×EC30.0	2×0021.0
LCD-P	Path loss of code group delineation. See Table 26 , page 46. This is also reported to the far end if it persists for at least 3 ms.	Near end defect	2×EC31.2	2×0021.3
LOPC	Loss of optical carrier alarm. This is an input from the XFP module's loss of signal output. The polarity can be inverted for use with other module types. This defect can be used independently or in place of LOS.	Near end defect	2×EC30.12	2×EF03.11
LOS	The PMA circuitry detects a Loss Of Signal (LOS) defect if the input signal falls below the assert threshold. Refer the PMA LOS section for more details. When a PMA LOS is declared the framer is held in reset to prevent it from looking for a frame boundary.	Near end defect	2×EC30.11	2×0021.6
SEF	Severely errored frame. Generated when device cannot frame to A1 A2 pattern. SEF indicates synchronization process is not in the SYNC state, as defined by the state diagram of IEEE 802.3ae clause 50.4.2.	Near end defect; propagated to PCS	2×EC31.7	2×0021.11
LOF	Generated when SEF persists for 3 ms. Terminated when no SEF occurs for 1 ms to 3 ms.	Near end defect	2×EC31.6	2×0021.7

Table 28 • Defects and Anomalies (continued)

Defect or Anomaly	Description	Type	Force Bit	Status Bit
B1 PMTICK error count is nonzero	BIP-N(S) - 32-bit near end section BIP error counter is nonzero.	Near end anomaly	2×EC31.5	2×EF03.7
B2 PMTICK error count is nonzero	BIP-N(L) - 32-bit near end line BIP error counter is nonzero.	Near end anomaly	2×EC31.4	2×EF03.6
B3 PMTICK error count is nonzero	BIP-N(P) - 32-bit near end path BIP error counter is nonzero.	Near end anomaly	2×EC31.3	2×EF03.5
REI-L	Line remote error indicator octet is nonzero. Far end BIP-N(L).	Far end anomaly	2×EC31.8	2×EF03.4
REI-L PMTICK error count is nonzero	Line remote error indicator is nonzero. Far end BIP-N(L).	Far end anomaly	2×EC31.1	2×EF03.2
RDI-L	Line remote defect indicator.	Far end defect	2×EC30.2	2×0021.5
REI-P	Path remote error indicator octet is nonzero. Far end BIP-N(P).	Far end anomaly	2×EC31.9	2×EF03.3
REI-P PMTICK error count is nonzero	Path remote error indicator. Far end BIP-N(P).	Far end anomaly	2×EC31.0	2×EF03.1
UNEQ-P	Unequipped path.	Near end defect	2×EC31.15	2×EF03.10
Far end UNEQ-P	Far end unequipped path.	Far end defect	2×EC31.11	2×EF03.9

3.5.8 Interrupt and Interrupt Masking

The VSC8486-11 generates interrupts for each defect and anomaly. The interrupts for the BIP error counts (B1, B2, and B3 counters) and the interrupts for the far end error counts (REI-L and REI-P) are generated when the PMTICK counters become nonzero. Mask enable bits propagate the interrupt pending event to the pins WIS_INTA and WIS_INTB. Each event can be optionally masked for each WIS_INTA/B pin.

For each defect or anomaly defined in IEEE Standard 802.3ae, the VSC8486-11 supports the standard WIS register. In addition the VSC8486-11 supports another set of registers in the WIS Vendor Specific area. These registers provide a STATUS bit to indicate the current real-time status of the event, a PENDING bit to indicate if the STATUS bit has changed state, and two mask enable bits for each interrupt pin (WIS_INTA and WIS_INTB). The STATUS bit is set if and only if the interrupt currently exists. This STATUS bit does not latch.

The defects and anomalies are constructed in a hierarchy such that lower order alarms are squelched when higher order events are detected. For more information about the dependencies between squelches and events, see the E-WIS interrupt registers, beginning with [Table 167](#), page 133 and [Table 98](#), page 111.

3.5.9 Overhead Serial Interfaces

The VSC8486-11 includes provisions for off-chip processing of the critical SONET/SDH transport overhead 9-bit words through two independent serial interfaces. The transmit overhead serial interface

(TOSI) is used to insert 9-bit words into the transmit frames, and the receive overhead serial interface (ROSI) is used to recover the 9-bit words from the received frames. The interfaces each consists of three pins: a clock output, a frame pulse output, and a data input (Tx) /output (Rx). These I/O are LVTTTL compatible for easy connection to an external device such as an FPGA.

Note: Extended WIS TOSI and ROSI do not support path overhead.

3.5.9.1 Transmit Overhead Serial Interface (TOSI)

The TOSI port enables the user to individually program 222 separate 9-bit words in the SONET/SDH overhead. The SONET/SDH frame rate is 8 kHz as signaled by the frame pulse (TFPOUT) signal. The TOSI port is clocked from a divided-down version of the WIS transmit clock made available on TCLKOUT. To provide a more standard clock rate, 9-bit dummy words are added per frame resulting in a clock running at one five-hundred-twelfth of the line rate or 19.44 MHz. For each 9-bit word, the external device indicates the desire to transmit that byte by using an enable indicator bit (EIB) that is appended to the beginning of the 9-bit word. If EIB = 0, the data on the serial interface is ignored for that overhead 9-bit word. If EIB = 1, the serial interface data takes precedence over the value generated within the VSC8486-11. The first EIB bit should be transmitted by the external device on the first rising edge of TCLKOUT after TFPOUT, as illustrated in the following illustration. The data should be provided with the most significant bit (MSB) first. After reception of the TOSI data for a complete frame, the values are placed in the overhead for the next transmitted frame.

Figure 32 • TOSI Timing Diagram

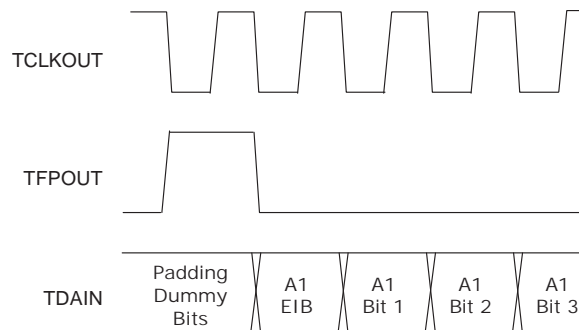

Some 9-bit words are error masks, such that the transmitted 9-bit word is the XOR of the TOSI 9-bit word and the predefined value within the chip if the EIB is enabled. This feature is best used for test purposes only.

The order of the 9-bit word required by the TOSI port is summarized in the following table, where the number of registers is the number of bytes on the serial interface and the number of bytes is the number of STS channels on which the byte is transmitted. Bytes 2 through 192 are concatenation indication bytes for both H1 and H2, not 192 different point locations as in an STS-192 frame.

Table 29 • TOSI/ROSI Addresses

Byte Name	9-Bit Word	TOSI/ROSI Byte Order	Number of Registers	Number of Bytes	Type
Frame Boundary	A1	0	1	192	Programmable byte that is identical for all locations
Frame Boundary	A2	1	1	192	Programmable byte that is identical for all locations
Section Trace	J0	2	1	1	Programmable byte
Section Growth	Z0	3	1	191	Programmable byte that is identical for all locations
Dummy Byte		4	1	1	Programmable byte

Table 29 • TOSI/ROSI Addresses (continued)

Byte Name	9-Bit Word	TOSI/ROSI Byte Order	Number of Registers	Number of Bytes	Type
Section BIP-8	B1	5	1	1	TOSI inserts error mask; ROSI extracts XOR of B1 value and received data
Orderwire	E1	6	1	1	Programmable byte
Section User Channel	F1	7	1	1	Programmable byte
Dummy Byte		8	1	1	Programmable bytes
Section DCC 1	D1	9	1	1	Programmable byte
Section DCC 2	D2	10	1	1	Programmable byte
Section DCC 3	D3	11	1	1	Programmable byte
Dummy Byte		12	1	1	Programmable byte
Pointer 1	H1	13	1	1	Programmable byte affecting the first H1 byte
Pointer 2	H2	14	1	1	Programmable byte affecting the first H2 byte
Pointer Action	H3	15	1	192	Programmable byte that is identical for all locations
Dummy Byte		16	1	1	Programmable byte
Line BIP-8	B2	17 to 208	192	192	TOSI inserts error mask for each byte; ROSI extracts XOR of B2 value and received data for each byte
Automatic Protection Switching (APS) channel and Remote Defect Indicator (RDI)	K1	209	1	1	Programmable byte
Automatic Protection Switching (APS) channel and Remote Defect Indicator (RDI)	K2	210	1	1	Programmable byte
Dummy Byte		211	1	1	Programmable byte
Line DCC 4	D4	212	1	1	Programmable byte
Line DCC 5	D5	213	1	1	Programmable byte
Line DCC 6	D6	214	1	1	Programmable byte
Dummy Byte		215	1	1	Programmable byte
Line DCC 7	D7	216	1	1	Programmable byte
Line DCC 8	D8	217	1	1	Programmable byte
Line DCC 9	D9	218	1	1	Programmable byte

Table 29 • TOSI/ROSI Addresses (continued)

Byte Name	9-Bit Word	TOSI/ROSI Byte Order	Number of Registers	Number of Bytes	Type
Dummy Byte		219	1	1	Programmable byte
Line DCC 10	D10	220	1	1	Programmable byte
Line DCC 11	D11	221	1	1	Programmable byte
Line DCC 12	D12	222	1	1	Programmable byte
Dummy Byte		223	1	1	Programmable byte
Synchronization Message	S1	224	1	1	Programmable byte
Growth 1	Z1	225	1	191	Programmable byte that is identical for all locations
Growth 2	Z2	226	1	190/191	Programmable byte that is identical for all locations; dependent upon 2×EC40.12
STS-1 REI-L	M0	227	1	1	Programmable byte
STS-N REI-L	M1	228	1	1	Programmable byte
Orderwire 2	E2	229	1	1	Programmable byte
Dummy Byte		230	1	1	Programmable byte
Padding Dummy Bytes		231 to 269	39		No function

3.5.9.2 Receive Overhead Serial Interface (ROSI)

The ROSI port extracts the same 222 overhead 9-bit words from the SONET/SDH frame, and consists of the clock output (RCLKOUT), frame pulse output (RFPOUT), and data output (RDAOUT). The ROSI port is clocked from a divided-down version of the WIS receive clock, and is valid during in-frame conditions only. As with the TOSI port, 9-bit dummy words are provided each frame period resulting in a 19.44 MHz RCLKOUT frequency. For each 9-bit word, including the 9-bit dummy words, an extra '0' bit is stuffed at the beginning of each byte so that the TOSI and ROSI clock rates are identical. The first stuff bit for each frame is transmitted by RDAOUT on the first rising edge of RCLKOUT after the frame pulse (RFPOUT).

Because the Receive path overhead can be split across two frames, the VSC8486-11 buffers the overhead for an additional frame time so that a complete path overhead is presented. [Table 29](#), page 51, outlines the order for each of the 9-bit words presented on the ROSI port. With the exception of the M0/M1 9-bit words, the extracted 9-bit words are from the first channel position. In place of parity and error 9-bit words, the VSC8486-11 outputs the result of an XOR between the calculated BIP and the received value. Therefore, a count of ones within each of the BIP 9-bit words should correspond with the internal error accumulators.

The following illustration shows the functional timing of the ROSI port.

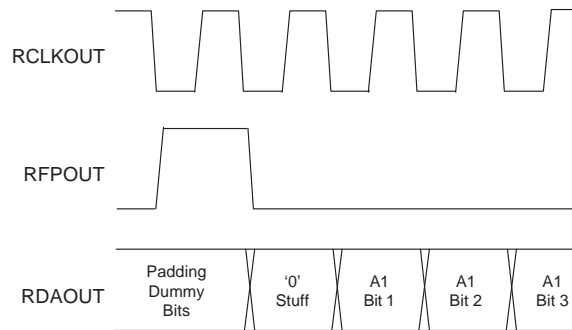
Figure 33 • ROSI Timing Diagram

3.5.10 Pattern Generator and Checker

The VSC8486-11 implements the square wave, PRBS31, and mixed frequency test patterns as described in section 50.3.8 of IEEE Standard 802.3ae as well as the Test Signal Structure (TSS) and continuous identical digits (CID) pattern.

The square wave pattern is selected asserting `WIS_TEST_PAT_SEL` (2×0007.3) while the generator is enabled by asserting `WIS_TEST_PAT_GEN` (2×0007.1). When `WIS_TEST_PAT_SEL` (2×0007.3) is deasserted the mixed frequency test pattern is selected. The square wave frequency is configured according to `WIS_SQWV_LEN` (2×0600.7:4). The `WIS_TEST_PAT_ANA` (2×0007.2) bit is used to enable the test pattern checker in the receive path. The checker does not operate on square wave receive traffic. Error counts from the mixed frequency pattern are presented in the SONET/SDH BIP-8 counters, `B1_CNT` (2×003C), `B2_CNT` (2×0039), and `B3_CNT` (2×003B).

The VSC8486-11 supports the PRBS31 test pattern as reflected in `PRBS31_SUPPORT` (2×0008.1). The transmitter/generator is enabled by asserting `WIS_TEST_PRBS_GEN` (2×0007.4) while the receiver/checker is enabled by asserting `WIS_TEST_PRBS_ANA` (2×0007.5). As the mixed frequency/square wave test patterns have priority over the PRBS31 pattern, `TEST_PAT_GEN` (2×0007.1) must be disabled for the PRBS31 test pattern to be sent. Error counts from the PRBS31 checker are available in `WIS_TEST_PAT_CNT` (2×0009). This register does not roll over after reaching its maximum count and is cleared after every read operation. Two status bits are available from the PRBS checker. The `PRBS_NZ` (2×EC51.1) bit indicates whether the error counter is nonzero. The `PRBS_SYNC` (2×EC51.0) bit if asserted indicates that checker is synchronized and actively checking received bits. For test purposes, the PRBS generator can inject single bit errors. By asserting `PRBS_INJ_ERR` (2×EC50.1), a single bit error is injected, resulting in three bit errors being detected within the checker. The value of three comes from the specification, which indicates one error should be detected for each tap within the checker.

3.5.11 Protocol Implementation Conformance Statement

The device supports all mandatory options and functions given in the Protocol Implementation Conformance Statement (PICS) in section 50.6 of IEEE Standard 802.3ae. Of the “Major capabilities/options,” the device supports the optional MDIO and PRBS31 test pattern mode, but does not support the optional XSBI compatible interface.

3.6 Physical Coding Sublayer

The physical coding sublayer (PCS) is defined in IEEE Standard 802.3ae Clause 49. The PCS is responsible for transferring data between the XGXS clock domain and the WIS/PMA clock domain. In addition, the PCS encodes and scrambles the data for efficient transport across the given medium.

The following illustration provides a block diagram of the PCS including how it glues the XGXS blocks to the WIS/PMA blocks and shows the alternate paths used by the E-PCS block which is discussed later.

Figure 34 • PCS Block Diagram

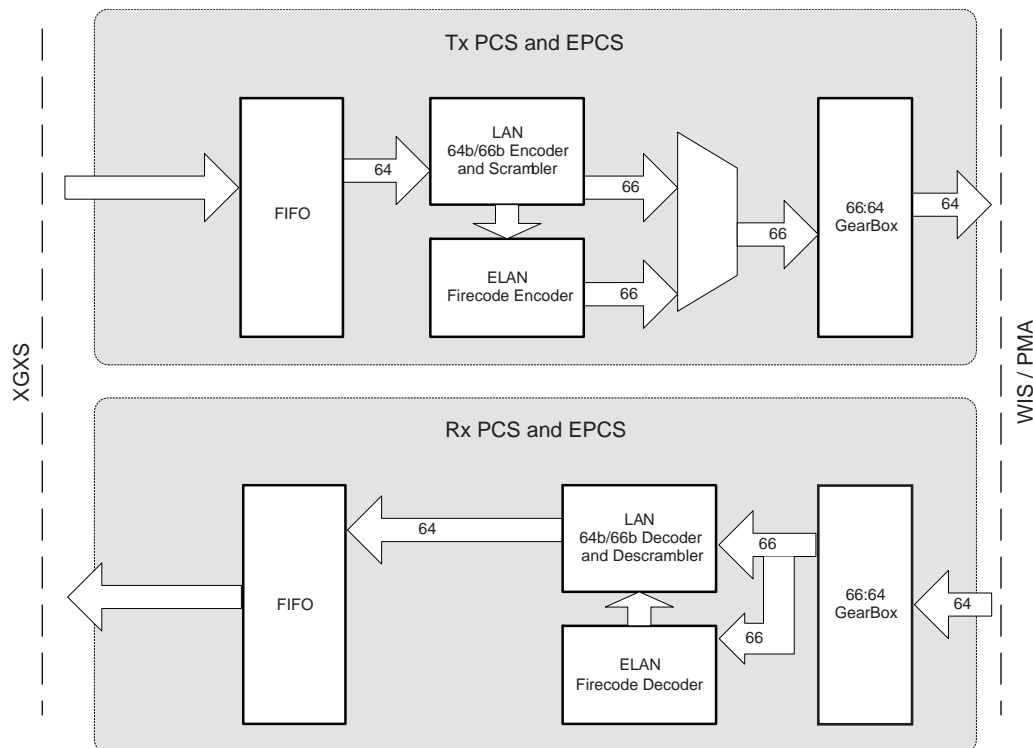

3.6.1 Control Codes

The VSC8486-11 supports the use of all control codes and ordered sets necessary for 10 GbE and 10 GFC operation. The following table lists the control characters, notation, and control codes.

Table 30 • Control Codes

Control Character	Notation ¹	XGMII Control Code	10-G BASE-R Control Code	10-G BASE-R O Code	8b/10b Code ²
Idle	/I/	0x07	0x00		K28.0 or K28.3 or K28.5
Start	/S/	0xfb	Encoded by block type field		K27.7
Terminate	/T/	0xfd	Encoded by block type field		K29.7
Error	/E/	0xfe	0x1e		K30.7
Sequence ordered_set	/Q/	0x9c	Encoded by block type field plus O code	0x0	K28.4
Reserved 0	/R/	0x1c	0x2d		K28.0
Reserved 1		0x3c	0x33		K28.1
Reserved 2	/A/	0x7c	0x4b		K28.3
Reserved 3	/K/	0xbc	0x55		K28.5
Reserved 4		0xdc	0x66		K28.6
Reserved 5		0xf7	0x78		K23.7
Signal ordered_set ³	/Fsig/	0x5c	Encoded by block type field plus O code	0xF	K28.2

1. The codes for /A/, /K/ and /R/ are used on the XAUI interface to signal idle.
2. For information only. The 8b/10b code is specified in Clause 36. Usage of the 8b/10b code for 10 Gbps operation is specified in Clause 4.
3. Reserved for INCITS T11 - 10 GFC μ s.

3.6.2 Transmit Path

In the transmit direction, the PCS accepts data from the XGXS interface, which has its own clock domain, and transfers the data into the PMA transmit clock domain. Clock rate disparity compensation takes place in a FIFO. The overflow/underflow status bits for the FIFO can be monitored at (3×8009.1:0). Based on the FIFO's fill level, idle characters are added or removed as needed. Two counters accumulate the number of added and removed idle characters, TX_IDLE_ADD (3×800C) and TX_IDLE_DROP (3×800D). These counters can be used to gain some insight into the clock rate disparity.

Once in the PMA clock domain, the characters are checked for validity. The occurrence of invalid characters cause the PCS_TXCHARERR_CNT (3×8014) register to increment. Likewise the occurrence of an invalid sequence causes the PCS_TXSEQERR_CNT (3×8012) register to increment. Transmitted data is handled according to IEEE Standard 802.3ae Clause 49.

The characters are then processed in a two-step manner. First the 64-bits are encoded and a 2-bit header is calculated to form a single 66-bit block. The two header bits are used for block delineation and classification. The only valid header codes are '01' to indicate a payload of all data octets and '10' to indicate the presence of one or more control characters within the payload. The second step is to maintain a DC balanced signal on the serial line, thus the 64-bit encoded payload is scrambled using a self-synchronizing scrambler that implements the polynomial $G(x) = 1 + x^{39} + x^{58}$. The header bits are not scrambled as they are already DC balanced. For debug purposes, the scrambler can be disabled by deasserting SCR_DIS (3×8005.9).

The 66-bit blocks are then passed to the PMA through a 66:64 gearbox. The gearbox merely feeds the 66-bit data into the WIS/PMA's 64-bit data path.

3.6.3 Receive Path

In the receive direction, the PCS accepts data from the WIS/PMA block and reformats it for transmission to the XGXS interface. Because of the data path width mismatches between the WIS/PMA and the PCS, a 64:66 gearbox is needed. The gearbox also performs block synchronization/alignment based upon the 2-bit synchronization header. When the receive logic receives 64 continuous valid sync headers the BLOCK_LOCK (3×0021.15) bit is asserted. This bit is a latch-high bit; therefore, a second read of the bit returns the current status. If 16 invalid block sync. headers are detected within a 125 μ s period, the PCS_HIGHBER (3×0021.14) bit is asserted. This bit is a latch-high bit, and therefore a second read of the bit returns the current status.

Once block synchronization is achieved, the occurrence of errored blocks are accumulated in the PCS_ERRORED_BLOCKS (3×0021.7:0) counter. An errored block is one that has one or more of the following defects:

- The sync field has a value of 00 or 11.
- The block type field contains a reserved value.
- Any control character contains an incorrect value (for more information about control code values, see Table 30, page 55).
- Any O code contains an incorrect value (for more information about control code values, see Table 30, page 55).
- The set of eight XGMII characters does not have a corresponding block format shown in the following illustration.

Figure 35 • 64b/66b Block Formats

Input Data	Sync	Block Payload										
Bit Position:	0 1	2									65	
Data Block Format:												
D0 D1 D2 D3/D4 D5 D6 D7	01	D ₀	D ₁	D ₂	D ₃	D ₄	D ₅	D ₆	D ₇			
Control Block Formats:		Block Type Field										
C0 C1 C2 C3/C4 C5 C6 C7	10	0x1e	C ₀	C ₁	C ₂	C ₃	C ₄	C ₅	C ₆	C ₇		
C0 C1 C2 C3/O4 D5 D6 D7	10	0x2d	C ₀	C ₁	C ₂	C ₃	O ₄	D ₅	D ₆	D ₇		
C0 C1 C2 C3/S4 D5 D6 D7	10	0x33	C ₀	C ₁	C ₂	C ₃			D ₅	D ₆	D ₇	
O0 D1 D2 D3/S4 D5 D6 D7	10	0x66	D ₁	D ₂	D ₃	O ₀			D ₅	D ₆	D ₇	
O0 D1 D2 D3/O4 D5 D6 D7	10	0x55	D ₁	D ₂	D ₃	O ₀	O ₄	D ₅	D ₆	D ₇		
S0 D1 D2 D3/D4 D5 D6 D7	10	0x78	D ₁	D ₂	D ₃	D ₄		D ₅	D ₆	D ₇		
O0 D1 D2 D3/C4 C5 C6 C7	10	0x4b	D ₁	D ₂	D ₃	O ₀	C ₄	C ₅	C ₆	C ₇		
T0 C1 C2 C3/C4 C5 C6 C7	10	0x87			C ₁	C ₂	C ₃	C ₄	C ₅	C ₆	C ₇	
D0 T1 C2 C3/C4 C5 C6 C7	10	0x99	D ₀			C ₂	C ₃	C ₄	C ₅	C ₆	C ₇	
D0 D1 T2 C3/C4 C5 C6 C7	10	0xaa	D ₀	D ₁			C ₃	C ₄	C ₅	C ₆	C ₇	
D0 D1 D2 T3/C4 C5 C6 C7	10	0xb4	D ₀	D ₁	D ₂			C ₄	C ₅	C ₆	C ₇	
D0 D1 D2 D3/T4 C5 C6 C7	10	0xcc	D ₀	D ₁	D ₂	D ₃			C ₅	C ₆	C ₇	
D0 D1 D2 D3/D4 T5 C6 C7	10	0xd2	D ₀	D ₁	D ₂	D ₃	D ₄			C ₆	C ₇	
D0 D1 D2 D3/D4 D5 T6 C7	10	0xe1	D ₀	D ₁	D ₂	D ₃	D ₄	D ₅			C ₇	
D0 D1 D2 D3/D4 D5 D6 T7	10	0xff	D ₀	D ₁	D ₂	D ₃	D ₄	D ₅	D ₆			

Valid blocks then recover their original payload data by being descrambled. The descrambler is the same polynomial as used by the transmitter. For test purposes, the descrambler can be disabled by asserting DSCR_DIS (3×8005.10). The data is checked for valid characters and sequencing. The occurrence of invalid characters causes the RXCHARERR_CNT (3×8015) to increment, while the occurrence of a sequence error causes the RXSEQERR_CNT (3×8011) to increment.

The data is passed from the PMA/WIS clock domain to the XGXS clock domain through a FIFO. The overflow/underflow status bits for the FIFO are reflected in RX_OFLOW (3×8009.3) and RX_UFLOW (3×8009.2). Based upon the FIFO's fill level, idle characters are added or removed as needed. RX_IDLE_ADD (3×800E) and RX_IDLE_DROP (3×800F) accumulate the number of added and dropped idle characters at this interface.

3.6.4 PCS Test Modes

The PCS block offers all of the standard defined test pattern generators and analyzers. In addition the VSC8486-11 supports a 64-bit static user pattern and the optional PRBS31 pattern. Two error counters are available. Each are saturating counters and cleared upon a read operation. The first, PCS_ERR_CNT (3×002B), is located in the IEEE Standard area while the 32-bit, PCS_VSERR_CNT (3×8007–3×8008), is located in the vendor specific area.

The IEEE specification defines two test pattern modes, a square wave generator and a pseudo-random test pattern. The square wave generator is enabled by first selecting the square wave pattern by asserting PCS_TSTPAT_SEL (3×002A.1) then enabling the test pattern generator PCS_TSTPAT_GEN (3×002A.3). The period of the square wave can be controlled in terms of bit times by writing to PCS_SQPW (3×8004). There is no associated square wave checker within the VSC8486-11. The pseudo-random test pattern is selected by deasserting PCS_TSTPAT_SEL (3×002A.1). The pseudo-random test pattern contains two data modes. When PCS_TSTDAT_SEL (3×002A.0) is deasserted, the pseudo-random pattern is a revolving series of four blocks with each block 128-bits in

length. The four blocks are the resultant bit sequence produced by the PCS scrambler when preloaded with the following seeds:

- PCS_SEEDA (3×0022–3×0025)
- PCS_SEEDA invert
- PCS_SEEDB (3×0026–3×0029)
- PCS_SEEDB invert

The pattern generator is enabled by asserting PCS_TSTPAT_GEN (3×002A.3), while the analyzer is enabled by asserting PCS_TSTPAT_ANA (3×002A.2). Errors are accumulated in the clear-on-read saturating counter, PCS_ERR_CNT (3×002B). In pseudo-random pattern mode, the error counter counts the number of errored blocks.

Support for the optional PRBS31 pattern is indicated by PCS_PRBS31_ABILITY (3×0020.2) whose default is high. The PRBS31 test generator is selected by asserting PCS_PRBS31_GEN (3×002A.4) while the checker is enabled by asserting PCS_PRBS31_ANA (3×002A.5). IEEE standards specify that the error counter should increment for each linear feedback shift register (LFSR) tap that a bit is in error. Therefore, a single bit error increments the counter by 3 as there are three taps in the PRBS31 polynomial.

The user defined 64-bit static pattern can be written to PCS_USRPAT (3×8000–3×8003) and enabled by asserting PCS_USRPAT_ENA (3×8005.0) and PCS_TSTPAT_GEN (3×002A.3).

3.7 Extended Physical Coding Sublayer

The VSC8486-11 provides an optional Extended PCS (E-PCS) mode to improve link quality (BER), provide a supervisory channel, and monitor the error rate at the PHY level. The E-PCS feature utilizes the frame format specified in the Common Electrical I/O Protocol (CEI-P) document created as an Implementation Agreement (IA) within the Optical Network Forum's (OIF). The CEI-P maintains a similar EMI spectrum as that generated by a standard PCS. The E-PCS mode operates at the same line rate as PCS and therefore does not require any special clocks or changes to the PMD layer.

When enabled, E-PCS mode provides a net electrical coding gain (NECG) of approximately 2.5 dB. For example, a link operating without E-PCS at a BER of 10^{-10} would operate at a BER of better than 10^{-16} with E-PCS.

Electronic dispersion compensated (EDC) applications produce burst errors due to the commonly used decision feedback equalizer (DFE) architecture. DFEs typically used in 10GBASE-LRM produce burst errors that are typically the same bit length as the number of taps. E-PCS mode is capable of correcting burst errors up to 7 bits in length, which is a common DFE tap size.

E-PCS mode is supported when the VSC8486-11 device is configured in LAN mode only, not in WAN mode.

3.7.1 Autonegotiation

The VSC8486-11 can be configured to autonegotiate between standard and extended PCS modes or can be controlled manually. The AUTONEG input pin, if set low, places the device into manual mode, meaning that E-PCS is enabled only when the EPCS input pin is set high. Both the AUTONEG and EPCS pins can be overridden by software by setting the AUTONEG_OVR (1×E605.13) and EPCS_OVR (1×E605.11) bits. Once overridden, the autonegotiation and E-PCS states are dependent upon the settings of AUTONEG_FORCE (1×E605.12) and EPCS_FORCE (1×E605.10).

In autonegotiation mode, the device transmits in the format defined by the EPCS mode after reset or powerup. The high-speed received data is processed by both the PCS and the E-PCS. If the received format is different than the transmitted format, the device switches the format to match the received data. During a loss of lock (LOL), the device continues to transmit in the currently negotiated format, but

changes to a new format if the receiver detects one. The following table describes the logic of the EPCS and AUTONEG bits.

Table 31 • E-PCS Logic

EPCS	AUTONEG	Transmission Format
0	0	Standard PCS.
0	1	Device begins transmitting in standard PCS format, but switches to E-PCS format if and only if the receiver detects E-PCS format.
1	0	Extended PCS.
1	1	Device begins transmitting in E-PCS format, but switches to standard PCS if and only if the receiver detects PCS data.

3.7.2 Frame Format

The frame format for E-PCS mode is given in Section 4.2 of the OIF CEI-P. The two-bit overhead of the 64B/66B PCS frame is replaced with a single overhead bit, thereby freeing up one bit per PCS frame. By accumulating these saved bits over 24 PCS frames, there are 24 new bits available to implement the supervisory channel and FEC Firecode. Seventeen of these bits (OH[19:3]) are used for framing, scrambler synchronization, error detection, and forward error correction. Three of these bits (OH[0:2]) are used to optionally determine link state and assist in error detection and forward error correction. Four of these bits (S[0:3]) are used as a supervisory channel.

Figure 36 • E-PCS Frame Format

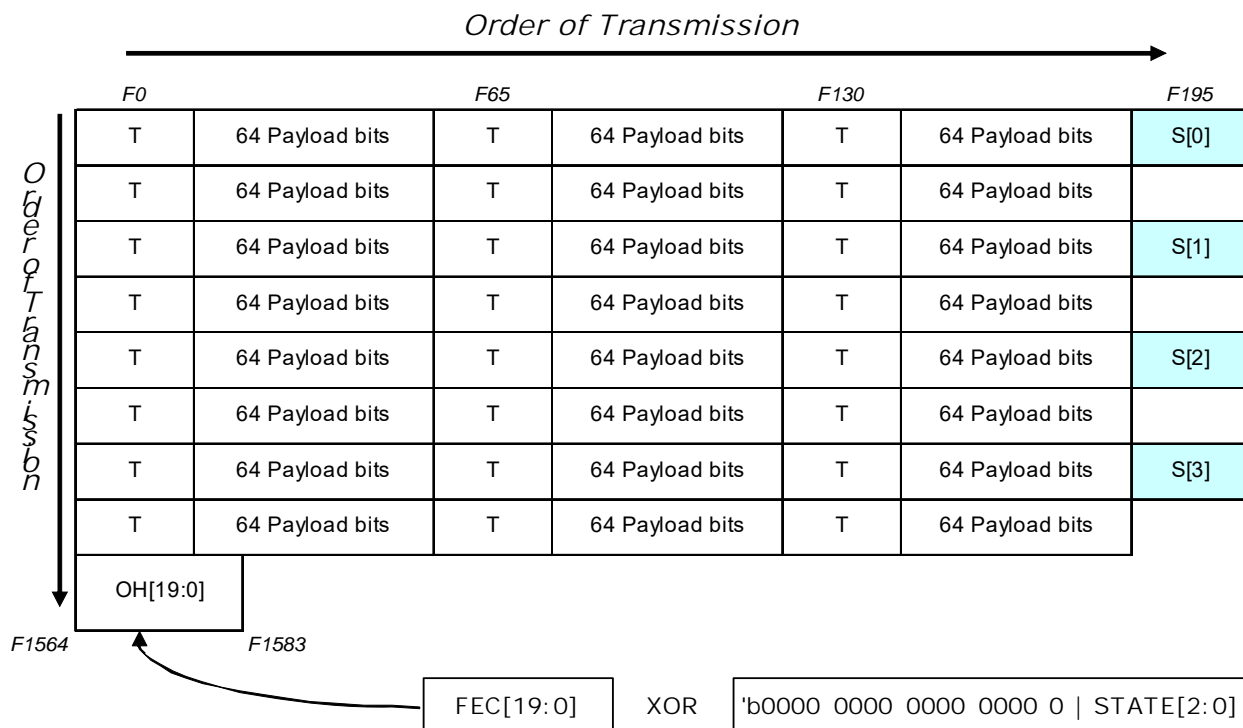

3.7.3 Link State Machines

The Rx and Tx Link training State Machines (LSMs) are compliant with the CEI-P specification. TX_LSM (3xE604.7:5) reports the current state of the Tx Link State Machine. This state information can be used

for diagnostics or monitoring of link training success. By default the Tx_LSM_ENA (3×E602.6) bit is deasserted, meaning that the Tx LSM skips the training sequence and handshake and moves directly to the idle state. If the VSC8486-11 is used in a system where training is desired, the Tx_LSM_ENA (3×E602.6) bit must be asserted during initial configuration. If Tx_LSM_ENA (3×E602.6) is asserted, the Tx LSM can be forced to restart and retrain the link by asserting TX_LSM_RESTART (3×E602.5). This bit has no value when operating with TX_LSM_ENA (3×E602.6) deasserted. Although intended for applications with multiple clients, the TX_LSM_HOLD (3×E602.4) is available for payload synchronization purposes. The TX_LSM_TIMEOUT (2×E603) value, also referred to as D1 in the CEI-P specification, is used to progress the LSM from the training state to the operational state in the case of a simplex (unidirectional) link application.

Within the receive link state machine the current state is reflected in RX_LSM (3×E605.2:0). The criteria for moving among Rx LSM states is based upon consecutive state indications being stable for a number of frames. This number, also known as the accepted value, is set in RX_LSM_R1 (3×E602.3:0) in units of CEI-P frames. The link's status of in-frame or out-of-frame is indicated in RX_IN_FRM (3×E605.4). The following illustration shows the E-PCS Framing State Diagram. The in-frame condition occurs when the number of consecutive E-PCS frames without parity errors (M2) exceeds 4. The out-of-frame condition occurs when the number of consecutive frames with parity errors (M1) exceeds 15.

Figure 37 • E-PCS Framing State Diagram

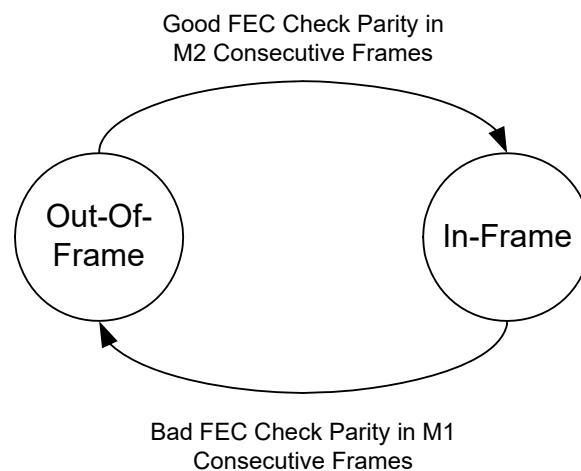

3.7.4 FEC Controls and Feedback

The forward error correction (FEC) code also known as the Firecode, occupies the last 20 bits within the E-PCS frame. Two counters are used to provide a rough indication of the link quality. The RX_FIXED_CNT (3×E605) frame counter displays the number of E-PCS frames in which errors were corrected over the previous one second. The RX_UNFIXED_CNT (3×E606) frame counter increments upon each E-PCS frame where the number of errors exceed the Firecode algorithm, namely an error burst greater than 7 bits per frame. The user must assert LATCH_N_CLR_CNT (3×E601.1) to latch the internal counter values into the MDIO accessible registers and clear the internal counters.

For purposes of BER characterization, the error correction mechanism can be disabled by deasserting EPCS_CORR (3×E601.2). By default, error correction is enabled.

3.7.5 Supervisory Channel

The four supervisory channel bits per E-PCS frame can be set for two different configurations. The first configuration involves sending static values as defined in TX_SCHAN (3×E601.7:10). These static bits are enabled by TX_SCHAN_EN (3×E601.6). The second configuration, which is the default, involves sending a 136-bit repeating message in a bit-wise fashion utilizing S[0]. In this mode, S[3:1] are automatically set to zero. The 136-bit message contains 8-bits of framing (0×7E) and a 128-bits of user programmable area. The intended 128-bit message is programmed in TX_MSG (3×E60A–3×E611). Once the message is programmed, the user must assert the TX_NEW_MSG (3×E601.0) bit. This action

latches the 128-bit message into internal registers, which are serialized and repetitively streamed out in the S[0] bit.

In the received direction, the S[0] bit is monitored for the framing byte (0×7E) to appear 136-bits apart, which is defined as frame alignment. After alignment, the incoming message bits are written to RX_MSG (3×E612–3×E619). Whenever the previous message and the current message differ, the RX_NEW_MSG (3×E604.3) bit asserts.

It is important to note that with a simplistic framing algorithm based upon a single byte (0×7E) occurring repeatedly 136-bits apart, any message containing the 0×7E byte can cause a false frame alignment. In such a case software must reconstruct the intended message.

3.8 XGMII Extender Sublayer

The PHY XS block interfaces from the four-lane 10 Gbps attachment unit interface (XAUI) to the PCS. Each AC-coupled lane has 8b/10b encoded data running at 3.125 Gbps (3.1875 Gbps for 10 GFC).

3.8.1 XAUI Receiver

The XAUI interface features on-chip terminations of 100 Ω for all XAUI inputs, as shown in the following illustration.

Figure 38 • XAUI Input Simplified Schematic (XAUI_RCVR)

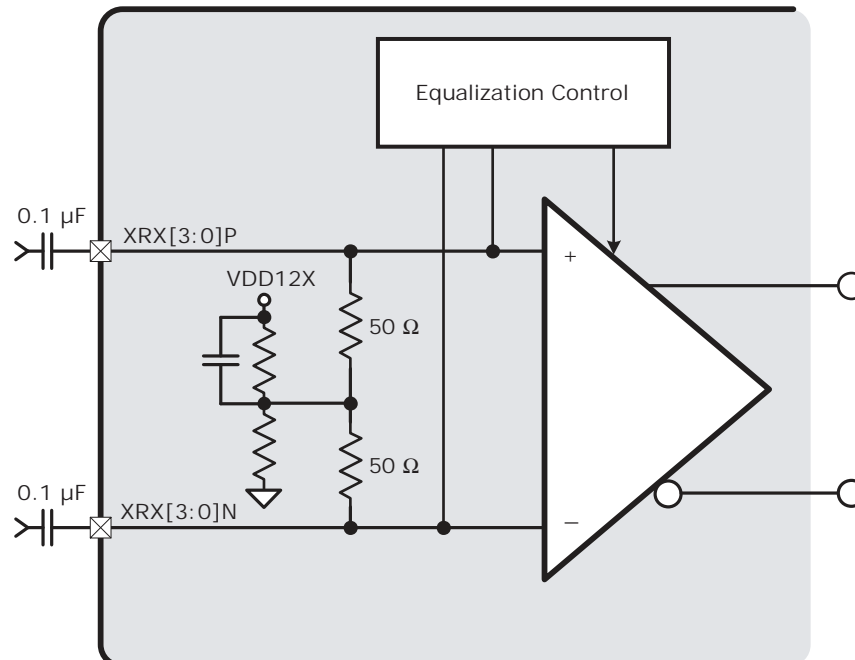

3.8.2 XAUI Loss of Signal

Each XRX[3:0]P/N channel's input buffer has a loss of signal (LOS) detection that can be accessed through the MDIO registers (4×8012.3:0). For each XAUI lane, a loss of signal level status is set low when the differential signal peak-to-peak swing exceeds the global deassert threshold level for that lane. The XAUI LOS assert and deassert thresholds cannot be set independently. Two bits in register (4×8011.3:2) are used to program four separate deassert and assert level ranges, as shown in the following table.

For each lane, a high indicates that the signal amplitude is below the assert threshold level. The LOS status bits are considered undefined when the signal swing is between the deassert threshold and assert threshold.

The approximate upper (deassert) and lower (assert) threshold levels are shown in the following table.

Table 32 • XAUI Lane LOS Threshold Summary

LOS Assert/ Deassert Threshold Range (4×8011.3:2)	Assert Threshold (mV)	Deassert Threshold (mV)	LOS Status (4×8012.3:0)	Remarks
00 (default)	50	175	Lane 3; bit 3 Lane 2; bit 2 Lane 1; bit 1 Lane 0; bit 0	For each lane: 1: LOS declared 0: LOS not declared
01	60	185	Lane 3; bit 3 Lane 2; bit 2 Lane 1; bit 1 Lane 0; bit 0	For each lane: 1: LOS declared 0: LOS not declared
10	70	195	Lane 3; bit 3 Lane 2; bit 2 Lane 1; bit 1 Lane 0; bit 0	For each lane: 1: LOS declared 0: LOS not declared
11	80	205	Lane 3; bit 3 Lane 2; bit 2 Lane 1; bit 1 Lane 0; bit 0	For each lane: 1: LOS declared 0: LOS not declared

3.8.3 XAUI Receiver Equalization

Incoming data on the XRX[3:0]P/N inputs typically contains a substantial amount of intersymbol interference (ISI) or deterministic jitter, which reduces the ability of the receiver to recover data without errors. Each XAUI lane includes a programmable equalizer circuit designed to effectively reduce the ISI resulting from copper cables or long printed circuit board (PCB) traces. XAUI lane equalization settings are programmed by writing to the appropriate bits in register LANE_EQ (4×8010.15:0) as shown in the following table.

Table 33 • XAUI Receiver Lane Equalization Setting

EQ Control Bits Per Lane	EQ Setting Per Lane	Remarks
Lane 3 (4×8010.3:0)	0000: 0.0 dB (default)	Optimum XAUI lane equalization settings are application specific. Typically, microstrip traces require less equalization to compensate because of lower losses than stripline construction. Normally, no equalization adjustment is required for XAUI tracks less than approximately 3 inches in FR-4 (microstrip or stripline). Beyond 3 inches, some amount of equalization is recommended for best performance.
Lane 2 (4×8010.7:4)	0001: 1.4 dB	
Lane 1 (4×8010.11:8)	0010: 2.2 dB	
Lane 0 (4×8010.15:12)	0011: 2.8 dB	
	0100: Not defined	
	0101: 4.5 dB	
	0110: 5.4 dB	
	0111: 6.1 dB	
	1000: Not defined	
	1001: 6.2 dB	
	1010: 7.1 dB	
	1011: 7.8 dB	
	1100: Not defined	
	1101: 10.0 dB	
	1110: 10.8 dB	
	1111: 11.6 dB	

3.8.4 XAUI Clock and Data Recovery

At the XAUI receiver, each channel contains an independent clock recovery unit (CRU) that accepts the selected serial input source, extracts the high-speed clock, and retimes the data. Each CRU automatically locks on to data and, if the data is not present, it automatically locks to the reference clock. The clock recovery unit must perform bit synchronization, which occurs when the CRU locks onto and properly samples the incoming serial data.

3.8.5 XAUI Code Group Synchronization

The retimed serial data stream is delineated into 10-bit code groups by the deserializer. A special 7-bit comma pattern, 0011111xxx or 1100000xxx (where x is don't care), is recognized by the receiver as a 10-bit code group boundary.

Character, or code group, alignment occurs when the deserializer synchronizes the 10-bit code group boundary to a comma pattern in the incoming serial data stream. If the receiver identifies a comma pattern in the incoming data stream that is misaligned to the current framing boundary and the receiver is in LOS state, the receiver resynchronizes the recovered data to align the data to the new comma pattern. Resynchronization ensures that the comma character is output on the internal 10-bit bus so that bits 0 through 9 equal 0011111xxx or 1100000xxx. If the comma pattern is aligned with the current framing boundary, then the Resynchronization does not change the current alignment.

The detection of a series of consecutive 10-bit code group violations is the mechanism by which loss of synchronization, LANE_SYNC (4×0018.3:0), is declared by the XAUI receiver. The loss of synchronization condition is cleared by the detection of a series of comma characters that are properly aligned on code group boundaries. For additional information, see IEEE Standard 802.3ae Clause 48, Figure 48-7 and the following illustration.

Figure 39 • Loss of Synchronization (Lane Sync) State Diagram

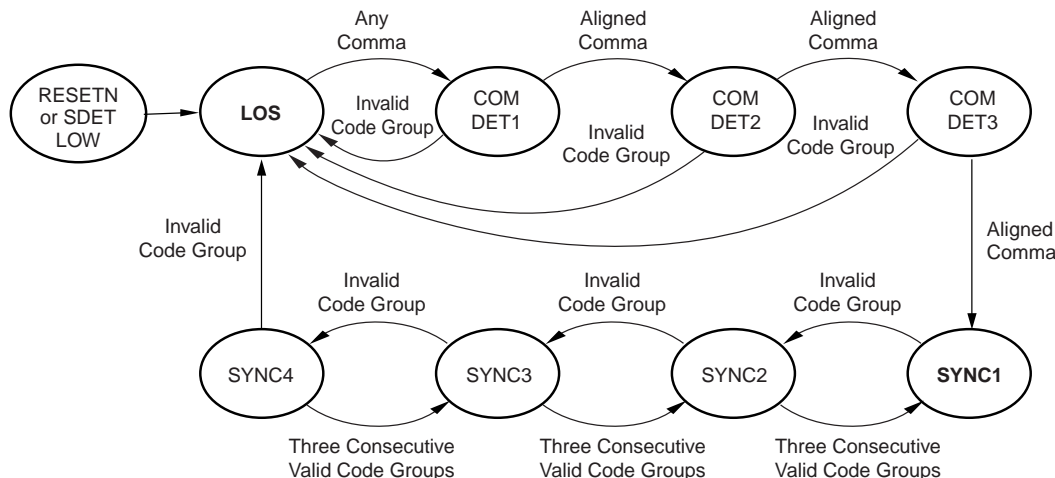

Comma detection is enabled only when in the loss of synchronization (LOS) state rather than at all times. This is desirable to prevent incorrect character realignment due to the appearance of false commas, resulting from single-bit errors.

3.8.6 XAUI Lane Deskew

XAUI lane skew occurs due to the skew between channels of a XAUI transmitter and the skew accumulated across the transmission medium. The VSC8486-11 can deskew up to 63-bit periods of lane-to-lane skew by using elastic buffers. XAUI channel lane deskew is performed by detecting the alignment character /A/ on all four lanes. The PHY XS LANES_ALIGNED bit (4×0018.12), when read as one, indicates all lanes are aligned.

For interchannel alignment to occur, the ||A|| ordered set consisting of four /A/ code groups must appear, one /A/ on each of the four XAUI lanes. This provides a unique synchronization point across the four serial data streams, which are used to align the received channels. Alignment status is governed by the

reception of $||A||$ ordered sets across the inputs, as shown in the following loss of alignment (LOA) state diagram.

Figure 40 • Loss of Alignment (LOA) State Diagram

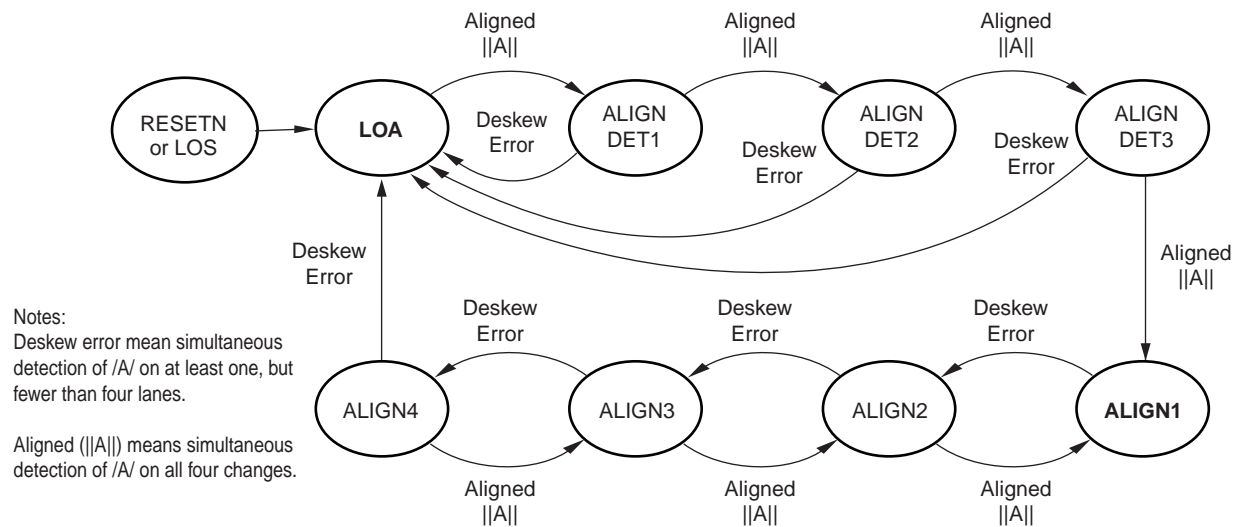

Successive synchronization points must be separated by at least 170 bit periods in order for up to 63 bit periods of lane to lane skew to be corrected unambiguously. An IEEE compliant source of XAUI data provides a minimum spacing between sync points of 17 code groups, or 170 bit periods (at least 16 other IDLE code groups must occur between consecutive occurrences of $||A||$). The alignment mechanism is always enabled when code group synchronization is attained on all four channels.

3.8.7 10b/8b Decoder

The 10-bit code group from the deserializer is decoded in the 10b/8b decoder, which outputs the data and control bits to the physical coding sublayer (PCS).

If the 10-bit code group does not match a valid code, a code group error is generated that increments the code group error counter GRPERR_CNT_LSW/MSW (4×8003/4×8004). Similarly, if the running disparity of the code group does not match the expected value, a disparity error is generated that increments a running disparity error counter DISPERR_CNT_LSW/MSW (4×8006/4×8007).

3.8.8 8b/10b Encoder and Serializer

Each channel contains an 8b/10b encoder that translates 8-bit data fed internally from the PCS block into a 10-bit code word. This data is then routed into a multiplexer that serializes the word, using the synthesized transmit clock. The most significant bit of the 10-bit data is transmitted first. Each channel has a serial output port, XTX[3:0]P/N, which consists of a differential XAUI output buffer operating at 3.125 Gbps (3.1875 Gbps for 10 GFC).

3.8.9 XAUI Transmitter

On the XAUI PHY transmit side (XTX[3:0]P/N), each polarity of the CML-type output driver is back-terminated with 50 Ω to VDDA12, providing a 100 Ω differential output impedance.

3.8.10 XAUI Transmitter Pre-Emphasis

The XAUI output stages include programmable peaking of the transmitted signal for each lane called pre-emphasis. The following illustration shows the pre-emphasis waveform definition.

Figure 41 • XAUI Output Differential Voltage with Pre-Emphasis

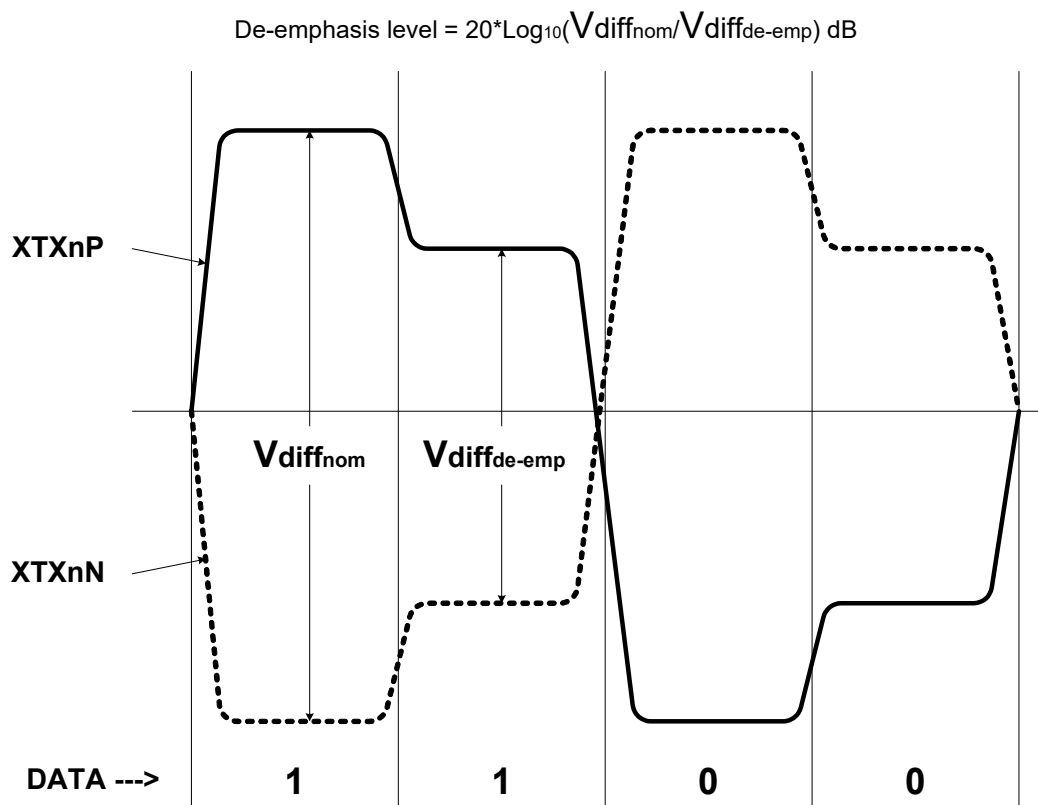

When used, transmit pre-emphasis causes the XAUI transmitter signals to be shaped to mitigate skin effect distortion, as shown in the preceding illustration. When signal pre-emphasis is employed, the effects of predistortion and skin effect distortion offset each other, and a higher quality waveform results at the receiving device.

XAUI lane pre-emphasis settings are programmed by writing to the appropriate bits in XAUI_PE_CFG (4×8011), as shown in the following table. Optimum XAUI lane pre-emphasis settings are application-specific. Normally no pre-emphasis adjustment is required for XAUI tracks less than approximately 5 inches in FR-4 (microstrip or stripline). Beyond about 5 inches, some amount of pre-emphasis is recommended for best performance.

Table 34 • XAUI Transmitter Lane Pre-Emphasis Setting

Pre-Emphasis Control Bits	Pre-Emphasis Setting Per Lane
Lane 3 (4×8011.5:4)	00: 0.0 dB (default)
Lane 2 (4×8011.8:7)	01: 2.5 dB
Lane 1 (4×8011.11:10)	10: 6.0 dB
Lane 0 (4×8011.14:13)	11: 12.0 dB

3.8.11 XAUI Transmitter Programmable-Output Swing

All XAUI output lanes include two peak-to-peak voltage swing settings. Asserting HS_ENA (4×8011.1) increases the output swing on all lanes by approximately 20% over the default output swing.

3.9 MDIO Serial Interface

The VSC8486-11 contains a management data input/output (MDIO) interface, as specified in IEEE Standard 802.3ae Clause 45. This section provides an overview of the operation of the MDIO interface. For more information, see IEEE Standard 802.3ae Clause 45.

3.9.1 MDIO Interface Operation

The operational sublayers within the device are individually known as MDIO-manageable devices (MMDs). Using the PRTAD[4:0] pins, the station management entity (STA) can access up to 32 PHYs. Using the 5-bit DEVAD field within the management frame format, up to 32 MMDs can be addressed in each PHY. The MDIO-manageable device addresses are shown in the following table.

Table 35 • MDIO-Manageable Device Addresses

Device Address	MMD Name
0	Reserved
1	PMA
2	WIS
3	PCS
4	PHY XS
5	DTE XS (not implemented)
6:29	Reserved
30	Vendor-specific name for two-wire serial CPU interface
31	Vendor specific name

The management frame format supports indirect addressing to provide more accessible register space within each MMD (for more information, see [Figure 42](#), page 67). The management frame field structure is shown in the following table.

Table 36 • Management Frame Format for Indirect Register Access

Management Frame Fields							Address/Data	Idle
Frame	PRE	ST	OP	PRTAD	DEVAD	TA		
Address	1...1	00	00	PPPPP	EEEE	10	AAAAAAAAAAAAAAAA	Z
Write	1...1	00	01	PPPPP	EEEE	10	DDDDDDDDDDDDDDDD	Z
Read	1...1	00	11	PPPPP	EEEE	Z0	DDDDDDDDDDDDDDDD	Z
Read increment	1...1	00	10	PPPPP	EEEE	Z0	DDDDDDDDDDDDDDDD	Z

A 16-bit address register stores the address of the register to be accessed by data transaction frames. The address register is overwritten by address frames. Upon device reset, the contents of the address register is set to zero. At power up, the contents of the address register are undefined.

Write, read, and post-read-increment-address frames access the register whose address is stored in the address register. Write and read frames do not modify the contents of the address register.

After receiving a post-read-increment-address frame and completing the read operation, the address register is incremented by one. When the register contains 65,535, the address register is not incremented.

The idle condition is a high-impedance state. All tri-state drivers are disabled, and the pull-up resistor pulls the MDIO line to a one.

At the beginning of each transaction, the station management entity (STA) sends a preamble (PRE) sequence of 32 continuous one-bits on MDIO during 32 corresponding cycles on the management data clock (MDC), providing a pattern that the MMD uses to establish synchronization. All MMDs observe the 32 continuous one-bits before responding to any transaction.

Figure 42 • MDIO Frame Format

PRE 32	ST	OP	PA 5	DA 5	TA	D 16	Z
--------	----	----	------	------	----	------	---

The MDIO frame format consists of the eight segments, shown above. Definitions for the segments are shown in the following table.

PRE 32	32 bits of 1 supplied by the STA.
ST	2 bits of 0, which indicates the start of frame.
OP	2 bits of Op-Code as described in IEEE 802.3ae Clause 45.
PA 5	5 bits of port address, which provides up to 32 ports to a physical bus.
DA 5	5 bits of destination MMD address, which provides up to 32 MMDs to a port.
TA	2 bits of turnaround time to change the bus ownership from the STA to MMD if required.
D 16	16 bits for address/data driven on the bus by the current master of the bus, the STA for write operation, and the MMD for a read or read-address-increment operation.
Z	Idle time, bus tri-stated.

The start of frame (ST) is indicated by the '00' pattern. Frames containing the ST = '01' pattern that is defined in IEEE Standard 802.3ae Clause 22, are ignored.

The operation code (OP) indicates the type of transaction being performed by the frame. A '00' pattern indicates that the frame payload contains the address of the register to access. A '01' pattern indicates that the frame payload contains data to be written to the register whose address is provided in the previous address frame. A '11' pattern indicates that the frame is a read operation. A '10' pattern indicates that the frame is a post-read-increment-address operation.

The port address (PRTAD) consists of five bits. The first bit to be transmitted and received is the MSB. The device address (DEVAD) also consists of five bits. The first bit transmitted and received is the MSB.

Turnaround (TA) is a two-bit time spacing between the DEVAD field and data field of a frame to avoid contention during a read transaction. For a read or post-read-increment-address transaction, the STA and MMD remain in a high-impedance state for the first-bit time of the turnaround. The MMD drives a zero bit during the second bit time of the turnaround of a read or post-read-increment-address transaction. During a write or address transaction, the STA drives a one for the first bit time of the turnaround and a zero for the second bit time of the turnaround.

The address or data field consists of 16 bits. For an address cycle, it contains the address of the register to be accessed on the next cycle. For read, write, and increment read cycles, the field contains the data for the register. The first bit transmitted and received is bit 15.

MDIO is a bidirectional signal that can be sourced by STA or the MMD. When STA sources the MDIO signal, a minimum of 10 ns of setup time and 10 ns of hold time with reference to the rising edge of MDC is provided, as shown in the following illustration.

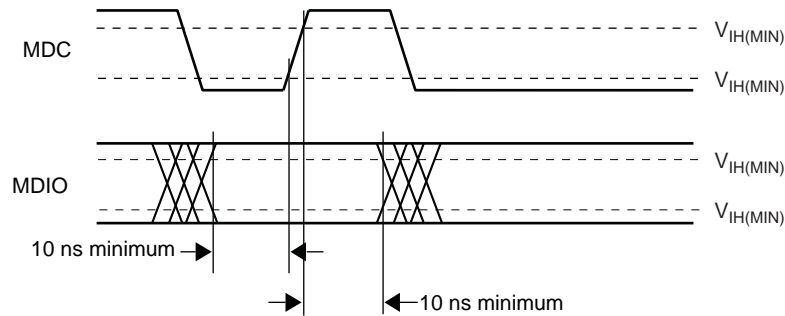
Figure 43 • Timing when MDIO is Sourced by STA

When MDIO is sourced by the MMD, it is sampled by the STA synchronously with respect to the rising edge of MDC. The clock-to-output delay from the MMD, as measured at STA, is a minimum of 0 ns and a maximum of 300 ns, as shown in the following illustration. For MDIO data sourcing, the last MDC of the STA must provide a falling edge before the MDC is tri-stated. Without this falling edge, the last bit of data sourced by the MMD write cycle will not be completed.

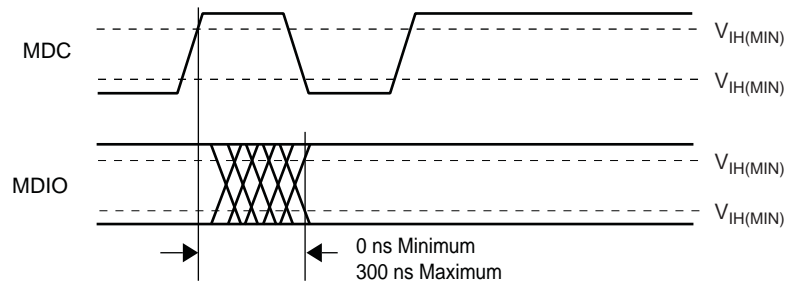
Figure 44 • Timing when MDIO is Sourced by MMD

3.10 Two-Wire Serial Interface

The VSC8486-11 contains a two-wire serial management interface that provides a communication bus to slave peripherals such as nonvolatile registers (NVR) or digital optical monitor (DOM) devices. The bus is intended to facilitate serial communication within a XENPAK/X2 module or with an XFP-compliant device; however, other devices can also be used. The two-wire serial bus is controlled using the MDIO interface. The two-wire serial interface is an industry-standard, master-only controller and supports two rates: standard (100 kbps) and fast (400 kbps). The MDIO control registers are shown in the following illustration.

Figure 45 • Serial Management Interface

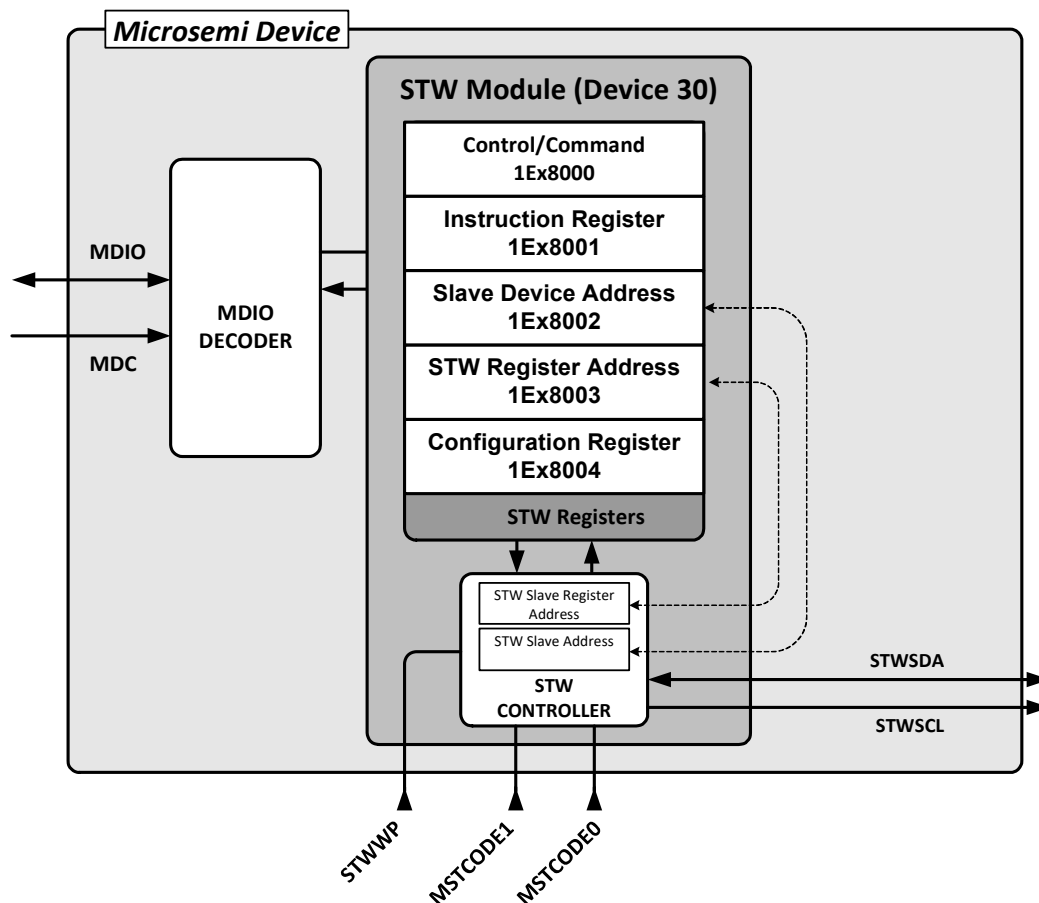

The two-wire serial interface uses a bidirectional data and clock signal named STWSDA and STWSCL, respectively. The two-wire serial write protect pin STWWP, when pulled high, inhibits two-wire serial write activity.

The two-wire serial interface controller supports 7-bit addressing, as configured in STW_ADDR_MODE (1E×8004.11).

Writing to the MDIO register STW_CTRL1 (1E×8000) initiates activity on the two-wire serial interface. The device supports automatic mode of operation, in which up to 256 bytes are automatically copied from an external NVR device to the internal two-wire serial interface registers or vice versa.

The two-wire serial controller logic operates independently from the MDIO interface. Thus, when the MDIO initiates a two-wire serial read/write command, the MDIO logic is not halted or locked while waiting for the two-wire serial command to complete. Because there is no queuing of two-wire serial commands, station management software must poll the two-wire serial controller to ensure that each two-wire serial command is complete before initiating the next command.

3.10.1 Two-Wire Serial Controller

The two-wire serial bus is controlled using five registers located in device 30 (0×1E).

3.10.1.1 STW_CTRL1 (1E×8000)

This register is the same as the NVR Control/Status register x8000 defined in XENPAK MSA Revision 3.0, with one exception. In addition to the XENPAK defined structure, the VSC8486-11 uses bit 8 of this register to set the two-wire serial interface operational mode. The MDIO decoder activates the two-wire serial interface module by writing to this register. Writes to this register through MDIO during a two-wire serial interface action are ignored.

3.10.1.2 STW_DEVADDR (1E×8002)

This register stores the two-wire serial slave device address that is read or written. The 7-bit address is entered into bits 6:0 in the register. The two-wire serial controller does not directly use the register contents, but instead latches the contents into internal logic when SYNC_ADDR (1E×8001.9) is asserted. This allows the address register to be updated while the two-wire serial controller is active. All XFP modules use the same seven-bit address 0×A0, which, when entered into the registers, become 0×50.

3.10.1.3 STW_REGADDR (1E×8003)

This register is used to store the address of the two-wire serial target register, which is used to store the data read from or written to the slave device. Similar to register 1E×8002, this register is not directly used by the two-wire serial controller, but is latched into internal logic when SYNC_REGADDR (1E×8001.8) is asserted.

3.10.1.4 STW_CFG1 (1E×8004)

This register is used to configure the desired operating mode for the two-wire serial controller. Bits 11:9 configure the two-wire serial interface master bus controller operating characteristics, bus signaling speed, and addressing mode. Bit 12 sets the two-wire serial controller to make block reads or writes in accordance with the XENPAK or XFP register maps. The XFP or XENPAK register contents are mapped into 256 eight-bit registers beginning at internal address 1E×8007 and ending with 1E×8106.

The two-wire serial controller is initiated by writing to the STW_CTRL1 (1E×8000). After each transaction begins the controller updates the STW_CMDSTAT (1E×8000.3:2) field with a '10' command in progress status. In this state, the MDIO interface cannot read or write to the two-wire serial control registers. After the controller completes the data read or write transaction, the STW_CMDSTAT (1E×8000.3:2) field is updated to either '01' to reflect a successful operation or '11' to reflect a failed operation. The MDIO interface then regains access to the two-wire serial controller registers. The following illustration shows the state diagram of the two-wire serial controller.

Figure 46 • Two-Wire Serial Access State Diagram

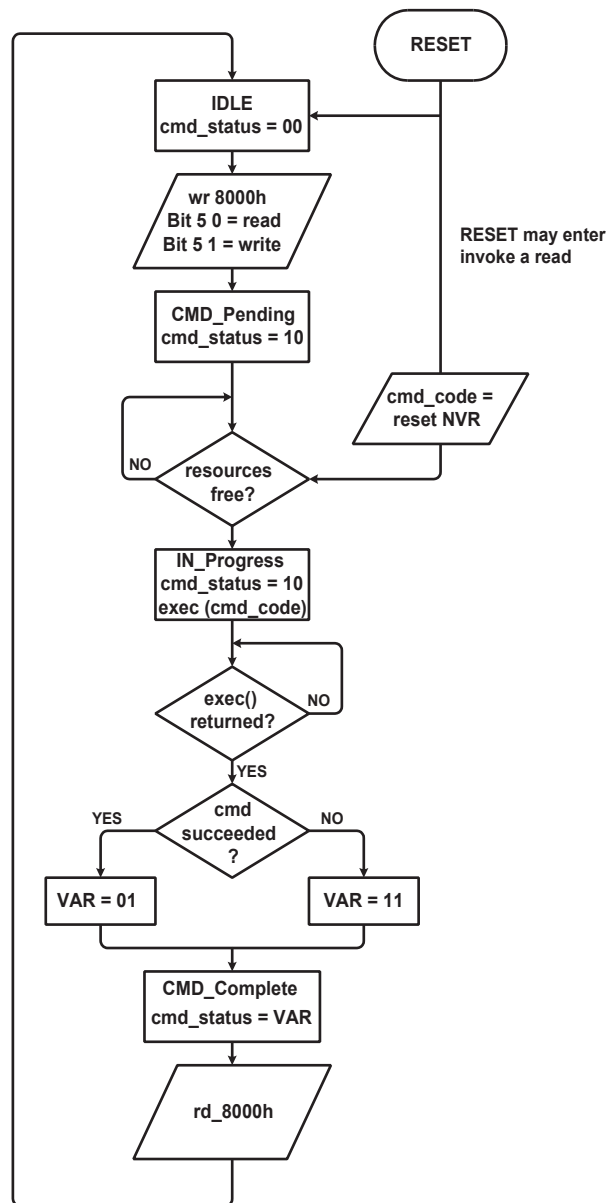

3.10.2 Automatic Mode

Automatic mode provides easy access to nonvolatile registers (NVR), such as EEPROM, used in XENPAK and XFP modules. In automatic mode, the two-wire serial interface controller performs reads or writes to different sections of nonvolatile memory according to the value of the extended command bits, STW_EXT_CMD (1E×8000.1:0). A value of '11' reads or writes all NVR contents, which is compliant with XENPAK MSA revision 3.0, section 10.10. STW_CMD (1E×8000.5) determines whether the operation is read or write.

In automatic mode, the two-wire serial interface maps internal registers 1E×8007 through 1E×8106 to external NVR address 0 to 255. To perform an automatic read, first write STW_DEVADDR (1E×8002), and then write STW_CTRL1 (1E×8000) using the proper settings. The two-wire serial interface controller reads the data stored in a certain section of NVR, which is defined by STW_EXT_CMD (1E×8000.1:0), and saves data to the corresponding section of internal VSC8486-11 registers. For example, if the data written to STW_CTRL1 (1E×8000) is 0×0000, the two-wire serial interface controller reads XFP

EEPROM bytes 2–57, and stores the data in registers 1E×8009 to 1E×8040. The automatic write operation is similar.

The auto read or write operations are compatible with the ATMEL AT24Cxx series serial two-wire EEPROM. For a detailed description of the read or write operations, see the ATMEL AT24Cxx Series Two-Wire Serial EEPROM specification. After the read or write operation is complete, the two-wire serial interface controller writes to STW_CMD_STATUS (1E×8000.3:2) to set the appropriate code. A '01' indicates a successful operation, and a '11' indicates a failed operation.

Use the following procedure to perform an automatic block read operation:

1. Write the address of the slave device to the Slave Device Address register (1E×8002) (50'h for XFP modules).
2. Write to the configuration register (1E×8004) bit 12 = 1 (XFP module).
3. Write 0×0000 to STW_CTRL1 (1E×8000). XFP bytes 2 through 57 are auto read.

3.11 XFP or SFP+ Module Interface

Several VSC8486-11 I/O pins can be reconfigured (using MDIO) from their default function to interface with all of the XFP or SFP+ status and control I/O pins, including the two-wire serial bus.

In an XFP host application, the recommended pin connections are as shown in the following illustration.

Figure 47 • VSC8486-11 to XFP Host Recommended Interface Connections

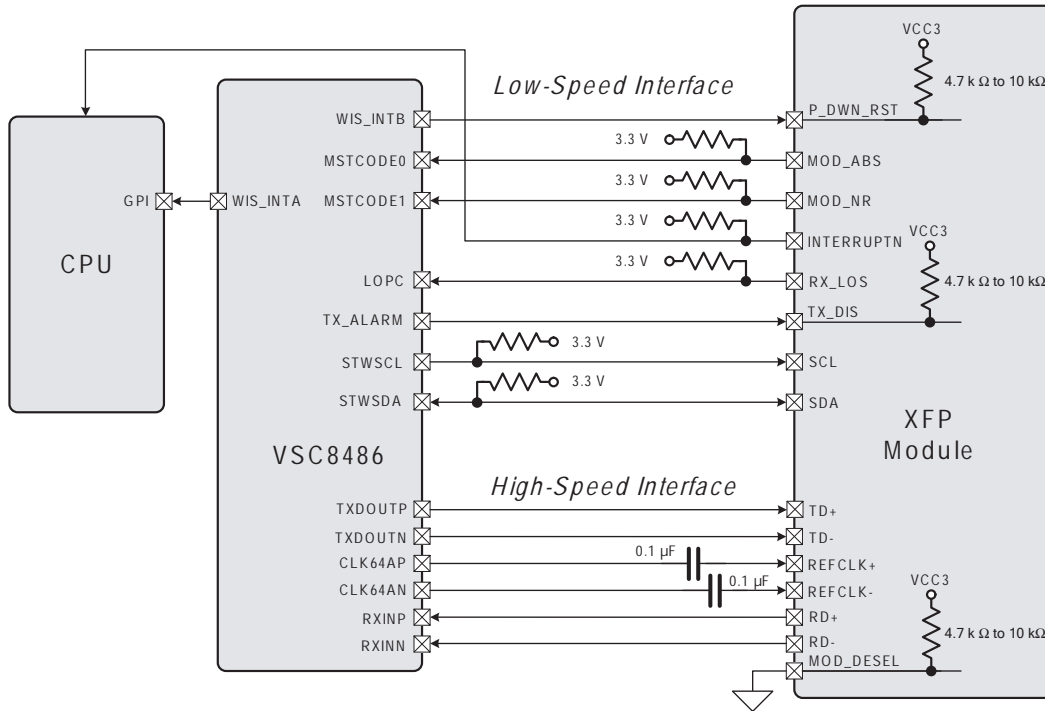

In an SFP+ host application, the recommended pin connections are as shown in the following illustration.

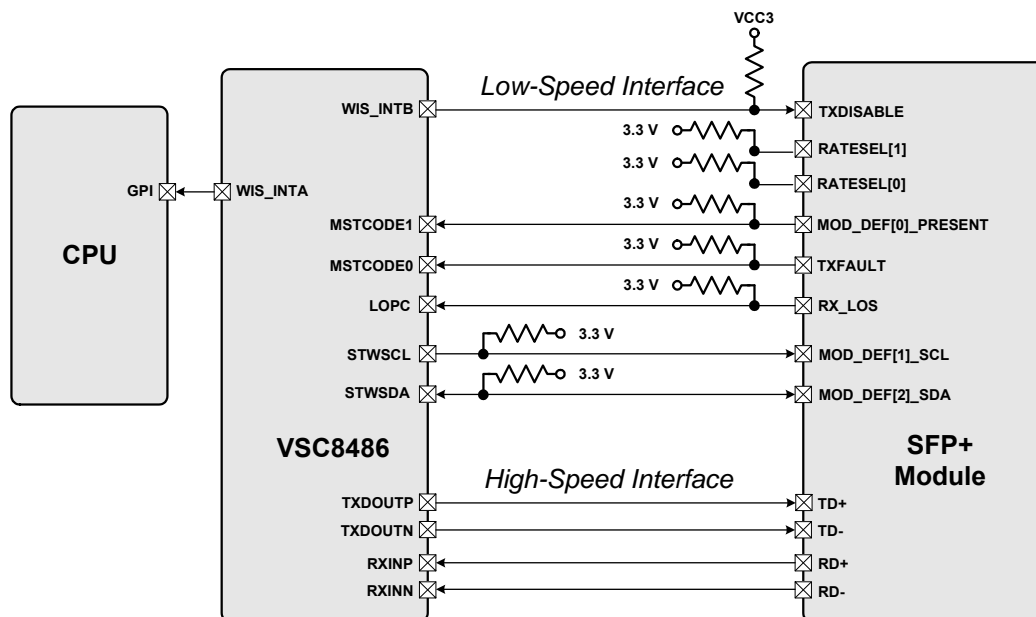
Figure 48 • VSC8486-11 to SFP+ Host Recommended Interface Connections

Note: To avoid a criss-cross in the connection to SFP+, it is recommended the TXDOUTP/N polarity be swapped. To program the TXDOUTP/N polarity, use register 1×8000.7.

Each of the recommended low-speed interface signals used on the VSC8486-11 in an XFP or SFP+ host application are summarized in the following table.

Note: Because the VSC8486-11 device operates at 10 gigabits, the SFP+ module pins KSO (pin 7) and RS1 (pin 9) should be tied high externally.

Table 37 • XFP or SFP+ Host Application Pin Connections Summary

VSC8486-11 Pin	I/O	Default Operation	XFP Host Operation	SFP+ Host Operation	Comments
WIS_INTB	Open-drain output	XFP module P_DWN_RST	XFP module P_DWN_RST	SFP+ module TXDISABLE	Pull-up resistor provided inside the XFP or SFP+ module. See register 1×E902.2:0 and 1×E901.9 for additional options. Polarity invert (1×E902.1 and 1×E605.15).
MSTCODE0 ¹	LVTTTL input	Two-wire serial high-speed master code0	MOD_ABS or INTERRUPT N	Not used with SFP+	See interrupt pending register (2×EF00.14:12) and mask (2×EF01.14:12) and pin status (1×E607.15:13).
MSTCODE1 ¹	LVTTTL input	Two-wire serial high-speed master code1	MOD_NR	GPIO_PRESE NT	See interrupt pending register (2×EF00.14:12) and mask (2×EF01.14:12) and pin status (1×E607.15:13).
LOPC	LVTTTL input	Loss of optical signal	Loss of optical signal	Loss of optical signal	Provide pull-up externally, nominally 4.7 kΩ. Provide pin status on 1×E607.0.
TX_ALARM	Open-drain output	Global SERDES transmit channel fault	TX_DIS	Not used with SFP+	For XFP, configure as GPO using 1×E901.14:13 set to 10 (default is 00) and then use 1×E901.8 set to force.

Table 37 • XFP or SFP+ Host Application Pin Connections Summary (continued)

VSC8486-11 Pin	I/O	Default Operation	XFP Host Operation	SFP+ Host Operation	Comments
STWSCL	Open-drain output	Two-wire serial clock source	SCL	SCL	Two-wire serial interface clock. See 1×E900.3:0.
STWSDA	Bidirectional open-drain output	Two-wire serial bidirectional data line	SDA	SDA	Two-wire serial interface data line. See 1×E900.3:0.
TXDOUTP/N	CML diff pair output	XFI Tx	TD+/-	TD+/-	10-gigabit serial data from the VSC8486-11 to the XFP or SFP+ module.
REFCLKAP/N	CML diff pair output	Div/64 reference clock to XFP	REFCLKP/N	REFCLKP/N	For XFP, CLK64AP/N (CMU/64) enabled by default. Disable using CLK64A_EN or register 1×E602.9.
RXINP/N	CML diff pair output	XFI Rx	RD+/-	RD+/-	10-gigabit serial data to the VSC8486-11 from the XFP or SFP+ module.
WIS_INTA	Open-drain output	Selectable WIS interrupt output	Output to CPU	Output to CPU	Global XFP or SFP+ alarm interrupt signal to CPU.

1. With the MSTCODE[2:0] pins utilized for XFP or SFP+ operation, the two-wire serial interface can still be used in high-speed mode. To accomplish this, assert register bit 1×E900.3 to set the master code from registers 1×E900.2:0 instead of from the MSTCODE[2:0] pins.

3.11.1 General Purpose and LED Driver Outputs

The VSC8486-11 includes several output pins that are capable of directly driving light emitting diodes (LEDs) and are programmable through MDIO. These outputs use open drain configuration and require pull-up resistors as shown in the following diagram.

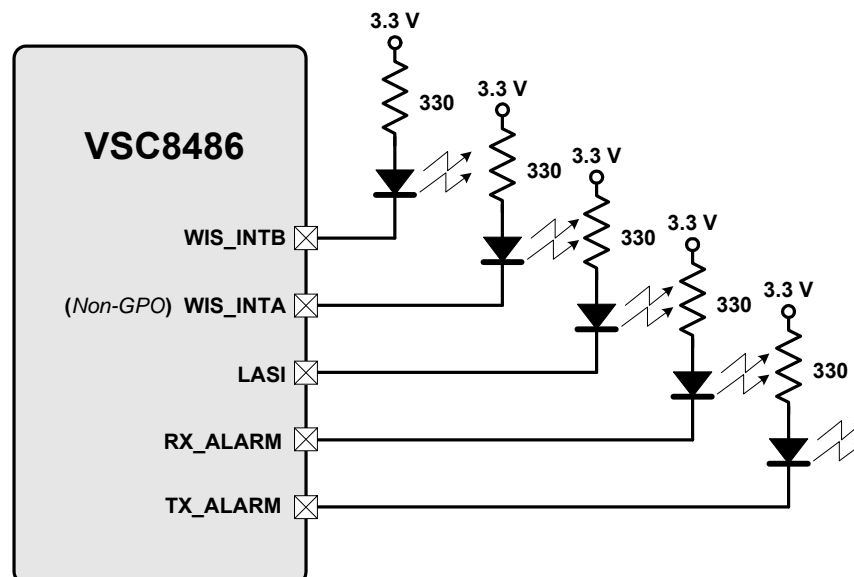
Figure 49 • Interrupt/Status/Activity LED Connections

The following table includes configuration options for the general purpose output (GPO) pins. Registers 1×E900, 1×E901, and 1×E902 are used to program the GPO function.

Table 38 • GPO Configuration Control Summary

Pin Name	Source Select	GPO Mode Output Control	Other Controls
WIS_INTB (L6)	1×E901.9 0: XFP module reset or SFP+ TXDISABLE (default) 1: WIS interrupt B function	If WIS interrupt B enabled (1×E901.9 = 1), then 1×E607.2 displays WIS_INTB pin status.	WIS_INTB_POL (1×E605.15). EWIS_MASKB_1 (2×EF02). EWIS_INTR_MASKB2 (2×EF06).
LASI (E5)	1×E901.10 0: Normal LASI output (default) 1: GPO mode	If GPO mode is active (1×E901.10 = 1), then bit 1×E901.6 is transmitted to LASI.	LASI output is disabled by default and enabled using 1E×9002.0 (reference is Xepak 3.0).
RX_ALARM (C4)	1×E901.12:11 00: Normal RX_ALARM (default) 01: Rx link/activity LED 10: GPO mode 11: Reserved	If GPO mode is active (1×E901.12:11 = 10), then bit GPO_RXALARM (1×E901.7) is transmitted to RX_ALARM.	RX_ALARM is clear on read by default and controlled using 1E×9003 (reference is Xepak 3.0). Other controls: Rx LED mode control (1×E901.1:0) and Rx data activity LED blink time (1×E901.4).
TX_ALARM (E4)	1×E901.14:13 00: Normal TX_ALARM (default) 01: Tx Link/Activity mode 10: GPO mode 11: Reserved	If GPO mode is active (1×E901.14:13 = 10), then bit GPO_TXALARM (1×E901.8) is transmitted to TX_ALARM.	TX_ALARM is clear on read by default and controlled using 1E×9004 (reference is Xepak 3.0). Other controls: Tx LED mode control (1×E901.3:2) and Tx data activity LED blink time (1×E901.5).

When the RX_ALARM output is programmed to Rx Link/Activity mode, an external LED responds as follows: Rx Activity Status indicates receipt of ||S|| characters, and Rx Link Status indicates PCS block lock = 1. (LED is on during block lock.)

The Combination Rx Link/Activity Status mode (1×E901.12:11 = 01) indicates the following:

- LED is off – Rx Link is down
- LED is on steady – Rx Link is up, but no ||S|| characters received
- LED blinking – Link is up and receiving ||S|| characters (steady state blink with off time set to approximately 100 ms)

When the TX_ALARM output is programmed to Tx Link/Activity mode, an external LED responds as follows: Tx Activity Status indicates transmission of ||S|| characters, and Tx Link Status indicates XAUI Lanes is aligned.

The Combination Tx Link/Activity Status mode (1×E901.14:13 = 01) indicates the following:

- LED is off – Tx Link is down
- LED is on steady – Tx Link is up, but no ||S|| characters transmitted
- LED blinking – Tx Link is up and transmitting ||S|| characters (steady state blink with off time set to approximately 100 ms)

Both Rx and Tx combination link/activity status outputs initially hold the LED on for up to 5 seconds, even if data activity begins in less time. If the link is down, the LED is off, regardless of elapsed time.

Note: The link/activity status outputs work for both PCS and E-PCS mode.

3.12 JTAG Access Port

A JTAG access port is provided on the VSC8486-11 transceiver to facilitate device level and board-level testing. All pins with the exception of the 10 Gbps serial pins and some analog pins can be accessed or

controlled through this port. This port is compliant with IEEE Standard 1149.1-2001 (subsequently referred to as the JTAG specification) with the five control TTL signals listed in the following table.

Table 39 • JTAG TTL Signals

Signal	Description
TCK	Test clock input
TMS	Test mode select input
TDI	Test data input
TDO	Test data output
TRSTB	Test reset input

These signals control the Test Access Port (TAP) and associated circuitry to enable boundary and internal scan testing operations.

To ensure reliability, a TRSTB input (instead of a power-on reset circuit) is provided to initialize the JTAG logic. This input, TRST* in the JTAG specification, is asserted when in the low (logic 0) state. The TRSTB, TDI, and TMS input pins have an on-chip, high-impedance, pull-up resistor connected to the VDDTTL supply so that an undriven input behaves as though a logic 1 were applied. Because the TAP controller is reset from the TRSTB signal and not a power-on reset circuit, the TAP controller, without a reset, can come up in an indeterminate state, thereby affecting the mode of inputs and outputs. It is imperative that users ensure that the TAP controller is reset prior to normal operation. This can be achieved by tying TRSTB low (logic 0) if JTAG is undesired or ensuring the pull-down is strong enough to overcome the internal pull-up resistor, yet weak enough that the JTAG exerciser can overcome the pull-down.

Boundary scan and internal scan testing is supported through the JTAG standard TAP and associated circuitry. This circuitry consists of a TAP controller, an instruction register with decoder, and four data registers, including a device ID register, a boundary scan register, a bypass register and the internal scan chain register. In general, these data registers consist of two parts: a serial shift register and a parallel output (or shadow) register. The parallel output registers maintain their values during shift operations and are loaded with new values from the shift register during an update state. The following illustration shows the architecture of the boundary scan test circuitry.

Figure 50 • JTAG TAP Boundary Scan Test Architecture

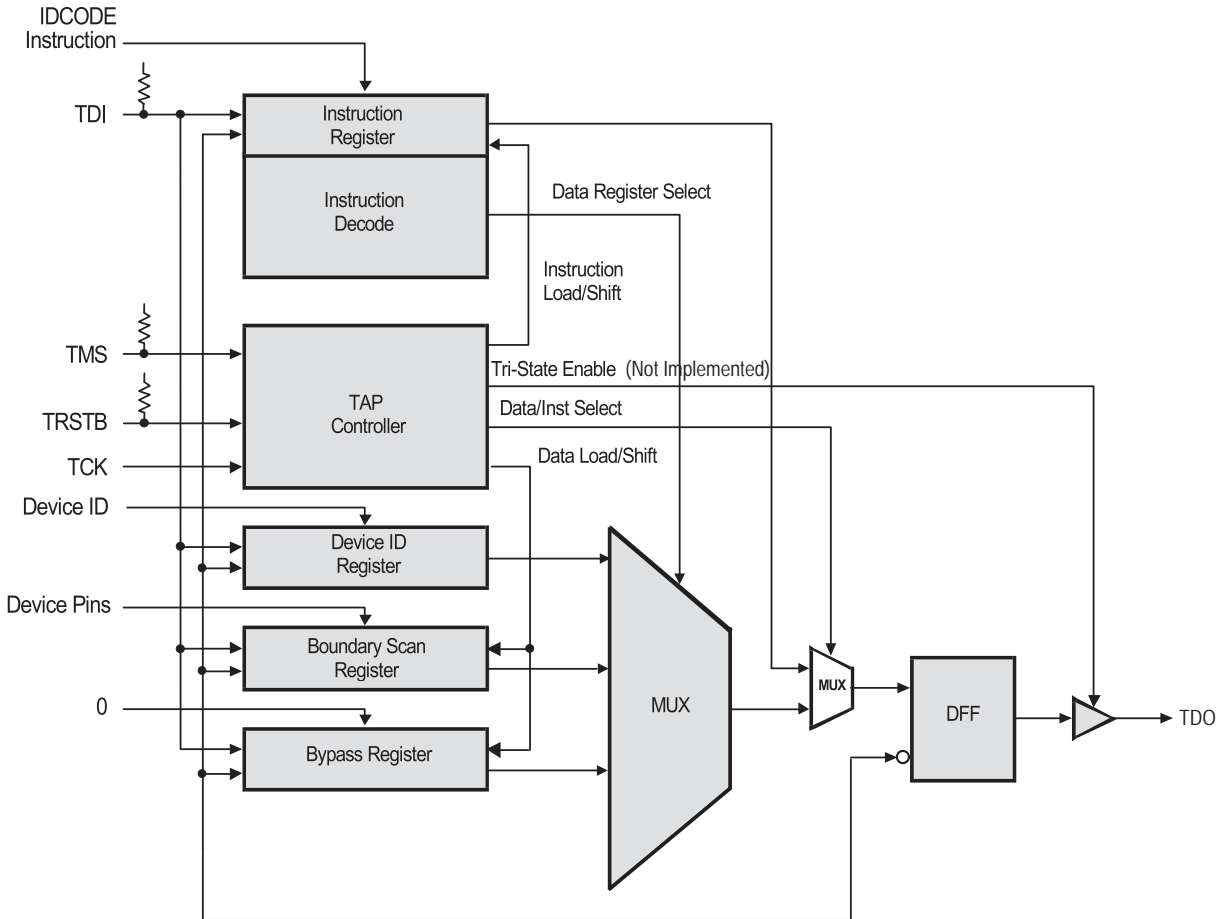

The TAP controller is a synchronous state machine that captures and shifts test data through the test registers. State transitions occur on the rising edge of TCK and are controlled by the TMS signal as illustrated in the following illustration.

Figure 51 • TAP Controller State Diagram

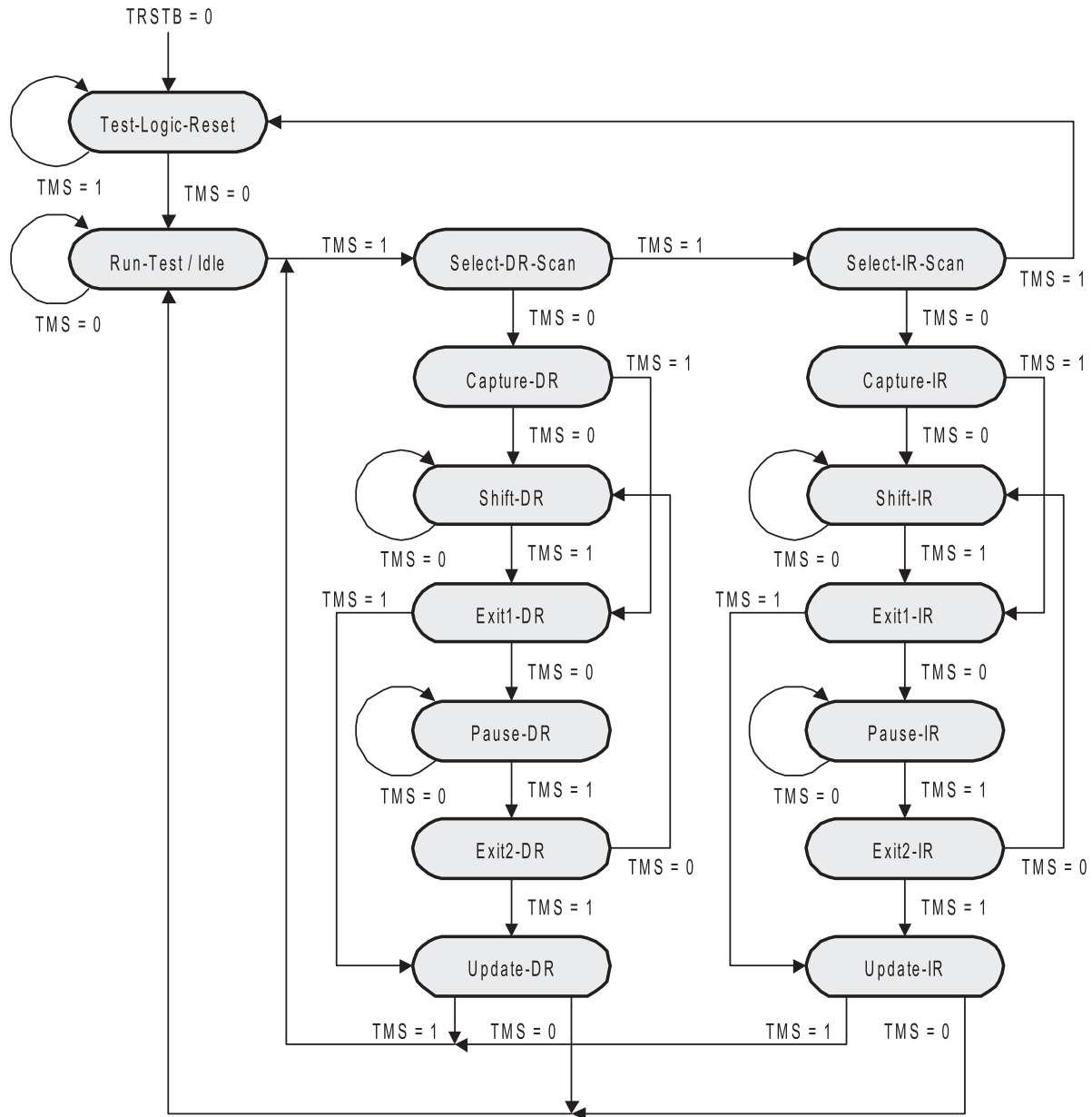

The following table describes the TAP Controller states.

Table 40 • TAP Controller States

TAP Controller State	Description
Test-Logic-Reset	Activating TRSTB forces the TAP Controller to asynchronously enter the Test-Logic-Reset state. This state is also entered synchronously within five TCK cycles if TMS is held high. In Test-Logic-Reset state all of the associated test logic is reset and disabled, allowing the device to operate normally. The Instruction register is loaded with the IDCODE instruction while the data registers are reset to logic 0.

Table 40 • TAP Controller States (continued)

TAP Controller State	Description
Run-Test/Idle	Run-Test/Idle state is an idle state in which the test logic is disabled and the device operates normally. It is different than the Test-Logic-Reset state in that the current state of the test logic is maintained.
Select-DR-Scan, Select-IR-Scan	These states are single TCK states that allow the selection of data register scan operations or Instruction register scan operations.
Capture-DR	Capture-DR state causes the selected serial data register to be loaded in parallel with a data value determined by the current instruction. The data is loaded on the rising edge of TCK as the TAP Controller transitions to the next state.
Shift-DR	Shift-DR state causes the selected data register to shift one bit in the direction going from TDI (MSB) towards TDO (LSB). Repeated single-bit shifts are performed on each rising TCK edge that TMS is held low.
Exit1-DR, Exit2-DR	These states are single TCK states at the end of a data register shift that allow a return to the Shift-DR state without going through the Capture-DR state, or allow the state machine to exit the data register shifting process back to the idle condition. TDO transitions to the high-impedance state on the first falling edge of TCK after the Exit1-DR state is entered.
Pause-DR	Pause-DR state allows the data register shifting process to be suspended without change or loss of the data register contents.
Update-DR	Update-DR state causes the parallel output (shadow) register part of the selected data register to be updated to match the value currently stored in the serial data register part. This update occurs on the first falling edge of TCK after the Update-DR state is entered. (Currently only the boundary scan register has parallel output registers.)
Capture-IR	Capture-IR state causes the Instruction register serial part to be loaded in parallel with status information. The status is loaded on the rising edge of TCK as the TAP Controller transitions to the next state. (Currently the status information is simply the IDCODE instruction.)
Shift-IR	Shift-IR state causes the Instruction register to shift one bit in the direction going from TDI (MSB) towards TDO (LSB). Repeated single-bit shifts are performed on each rising TCK edge that TMS is held low.
Exit1-IR, Exit2-IR	These states are single TCK states at the end of an Instruction register shift that allow a return to the Shift-IR state without going through the Capture-IR state, or allow the state machine to exit the Instruction register shifting process back to the idle condition. TDO transitions to the high-impedance state on the first falling edge of TCK after the Exit1-IR state is entered.
Pause-IR	Pause-IR state allows the Instruction register shifting process to be suspended without change or loss of the Instruction register contents.
Update-IR	Update-IR state causes the instruction currently loaded into the serial shift register part of the Instruction register to be loaded into the parallel output (shadow) register part of the Instruction register. This causes the instruction to become active. This activation of the instruction occurs on the first falling edge of TCK after the Update-IR state is entered.

3.12.1 Instruction Register

The four-bit Instruction register and associated decode circuitry determine the operation performed by the scan test logic, and which data register is selected in the scan path for the operation. In the

Test-Logic-Reset state, the Instruction register is initialized to the IDCODE instruction. The Instruction register is then loaded with status information during the Capture-IR state, in which the two least significant bits must be 01 for scan path testing purposes (currently the status information is the IDCODE instruction). Serially loaded instructions become active at the Update-IR state.

The following table lists supported test instructions, including the data register selected for each test, plus the device operating mode during the selected test. When the device is in test mode, the output pins are affected by the test operation. In normal mode, device inputs, outputs and internal logic are unaffected by the test operation.

Table 41 • Supported Boundary Scan Test Instructions

Instruction Code	Instruction	Selected Data Register	Device Operating Mode
0000	EXTEST	Boundary Scan	Test
0001	IDCODE	Device ID	Normal
0010	SAMPLE/PRELOA D	Boundary Scan	Normal
1111	BYPASS	Bypass	Normal
All others	Invalid	Unknown	Unknown

The following table provides a description of each supported test instruction.

Table 42 • Boundary Scan Test Instruction Descriptions

Instruction	Description
EXTEST	The EXTEST instruction enables board-level interconnect testing and device I/O level testing by allowing device inputs to be observed and controlled. The device inputs are captured during the Capture-DR state and subsequently shifted out on TDO with the Shift-DR state. Device outputs can be set by providing the desired values on TDI during the Shift-DR state, and then driving the outputs with the loaded values at the Update-DR state.
IDCODE	The IDCODE instruction enables the Device ID register to be read by serially shifting bit values out on TDO with the Shift-DR state. This instruction is automatically loaded by entering the Test-Logic-Reset state in addition to the normal serial instruction loading mechanism.
SAMPLE/ PRELOAD	The SAMPLE/PRELOAD instruction enables observation of device inputs and internal output signals while the normal operation. The signal values are loaded into the boundary scan register during the Capture-DR state and observed by shifting the values out with the Shift-DR state. The preload aspect of this instruction occurs at the Update-DR state, when values in the serial part of the boundary scan register are loaded into the parallel output (shadow) part. This allows the boundary scan register to be preloaded for subsequent test operations such as EXTTEST or CLAMP.
BYPASS	The BYPASS instruction allows serial data on TDI to be transferred to TDO with only one TCK delay. This facilitates board-level testing by allowing the serial test data to quickly pass on to the next device. The bypass register is loaded with a logic 0 during the Capture-DR state.

3.12.2 Device ID Register

The 32-bit device ID register is used to identify the manufacturer, part number, and version of the device through the JTAG test access port. When the IDCODE instruction is loaded, this identification data is loaded into the Device ID shift register during the Capture-DR state, and can be shifted out on TDO through the use of the Shift-DR state. The following table includes a description of the device identification information.

Note: The version number depicted does not necessarily reflect the latest revision of the VSC8486-11 device.

Table 43 • Device Identification Information

Type	Version Number	Part Number	Manufacturer ID	Fixed
Register bits	[31...28]	[27...12]	[11...1]	0
Hex value	0×2	0×8486	0×074	2

3.12.3 Bypass Register

The single-bit Bypass register enables system serial test data to bypass the device with only one TCK cycle delay. This register is used in the scan path during the BYPASS instruction. This register is set to logic 0 during the Capture-DR state.

3.12.4 Boundary Scan Register

The 127-bit Boundary Scan register (BSR) provides the means to force values on the device outputs and to capture values on the device inputs (and internal output signals). The direction of shift is from TDI (MSB), through bits 1–127, to TDO (LSB). The BSR bits and their associated device signals are summarized in the following table. A full Boundary Scan Description Language (BSDL) file is available upon request.

Table 44 • Boundary Scan Register Bits

BSR Bit	Device Signal	BSR Cell Type	BSR Bit	Device Signal	BSR Cell Type
0	RXALARM	OUT	39	TXD[29]	IN
1	TXALARM	OUT	40	TXD[30]	IN
2	LASI	OUT	41	TXD[31]	IN
3	REFSEL1	IN	42	TXC[3]	IN
4	REFSEL0	IN	43	PMTICK	IN
5	SPLITLOOPN	IN	44	TXONOFFI	IN
6	TXD[0]	IN	45	WIS_INTA	OUT
7	TXD[1]	IN	46	LP_16B	IN
8	TXD[2]	IN	47	LP_XGMII	IN
9	TXD[3]	IN	48	FORCE_AIS	IN
10	TXD[4]	IN	49	WANMODE	IN
11	TXD[5]	IN	50	LPP_10B	IN
12	TXD[6]	IN	51	RFPOUT	OUT
13	TXD[7]	IN	52	LP_XAUI	IN
14	TXC[0]	IN	53	CLK64A_EN	IN
15	TXD[8]	IN	54	LOPC	IN
16	TXD[9]	IN	55	RCLKOUT	OUT
17	TXD[10]	IN	56	RDAOUT	OUT

Table 44 • Boundary Scan Register Bits (continued)

BSR Bit	Device Signal	BSR Cell Type	BSR Bit	Device Signal	BSR Cell Type
18	TXD[11]	IN	57	TCLKOUT	OUT
19	TXC[1]	IN	58	TDAIN	IN
20	TXD[13]	IN	59	XTX0	OUT
21	TXD[14]	IN	60	XTX1	OUT
22	TXD[15]	IN	61	XTX2	OUT
23	TXD[12]	IN	62	XTX3	OUT
24	TXCLK	IN	63	XR3	IN
25	TXD[16]	IN	64	XR2	IN
26	TXD[17]	IN	65	XR1	IN
27	TXD[18]	IN	66	XR0	IN
28	TXD[19]	IN	67	IOMODESEL	IN
29	TXD[20]	IN	68	TFPOUT	OUT
30	TXD[21]	IN	69	MSTCODE[0]	IN
31	TXD[22]	IN	70	EPCS	IN
32	TXC[2]	IN	71	MSTCODE[1]	IN
33	TXD[23]	IN	72	AUTONEG	IN
34	TXD[24]	IN	73	STWWP	IN
35	TXD[25]	IN	74	MSTCODE[2]	IN
36	TXD[26]	IN	75	PRTAD[0]	IN
37	TXD[27]	IN	76	PRTAD[1]	IN
38	TXD[28]	IN	77	PRTAD[2]	IN
78	PRTAD[3]	IN	119	MDC	IN
79	PRTAD[4]	IN	120	STWSCL	IN
80	MDIO	IN	121	STWSCL	OUT
81	MDIO	OUT	122	STWSDA	IN
82	RXC[3]	OUT	123	STWSDA	OUT
83	RXD[31]	OUT	124	WIS_INTB	OUT
84	RXD[30]	OUT	125	RESETN	IN
85	RXD[29]	OUT	126	RXINOFFN	IN
86	RXD[28]	OUT			
87	RXD[27]	OUT			
88	RXD[26]	OUT			
89	RXD[25]	OUT			
90	RXD[24]	OUT			
91	RXC[2]	OUT			
92	RXD[23]	OUT			
93	RXD[22]	OUT			
94	RXD[21]	OUT			

Table 44 • Boundary Scan Register Bits (continued)

BSR Bit	Device Signal	BSR Cell Type	BSR Bit	Device Signal	BSR Cell Type
95	RXD[20]	OUT			
96	RXD[19]	OUT			
97	RXD[18]	OUT			
98	RXD[17]	OUT			
99	RXD[16]	OUT			
100	RXCLK	OUT			
101	RXD[13]	OUT			
102	RXD[15]	OUT			
103	RXD[14]	OUT			
104	RXC[1]	OUT			
105	RXD[12]	OUT			
106	RXD[11]	OUT			
107	RXD[10]	OUT			
108	RXD[9]	OUT			
109	RXD[6]	OUT			
110	RXC[0]	OUT			
111	RXD[7]	OUT			
112	RXD[8]	OUT			
113	RXD[5]	OUT			
114	RXD[4]	OUT			
115	RXD[3]	OUT			
116	RXD[2]	OUT			
117	RXD[1]	OUT			
118	RXD[0]	OUT			

3.13 Synchronous Ethernet

The VSC8486-11 device supports two modes for Synchronous Ethernet implementation: conventional mode and enhanced mode. The conventional mode requires either a REFCLK from an external narrow-banded PLL, which provides a 156.25 MHz clock ± 200 ppm even without any input to lock onto, or a REFCLK from an external oscillator to hold in its place until a clean recovered clock is available.

The enhanced mode eliminates this transient period or clock switching by providing separate clock sources for the PMA's CMU and CRU. An external PLL is required for jitter clean up. This section presents the differences between the conventional and enhanced modes.

3.13.1 About Conventional Mode

For Synchronous Ethernet application in conventional mode, the recovered clock from the XFI input data is used to generate the REFCLK for the transmitter of all PHYs and in turn the REFCLK is needed to recover the clock. Because the REFCLK and recovered clock are needed and are dependent on each other, the conventional method for Synchronous Ethernet configuration is to provide the REFCLK from an external narrow-banded PLL so that the PLL output is within 100 ppm of the required 156.25 MHz, even if there is no input at the PLL for the PLL to lock onto. When the recovered clock is available from the VSC8486-11 device, the PLL will lock onto the recovered clock to achieve synchronization between the Tx clock and the Rx clock of the PHY.

Another alternative is to start with an oscillator to generate the required 156.25 MHz and then switch to a recovered clock (with clean jitter and adjusted frequency) when available.

A typical overview of how to perform synchronization of the CMU transmit clock to the CRU recovered clock are as follows:

- Recover the clock from the XFI input in each line card
- Indicate the strength of the recovered clock signal
- Select the recovered clock from the different line cards
- Translate the recovered clock frequency to the reference clock frequency
- Clean up the jitter of the recovered clock
- Distribute the recovered clock as the transmit clock to all PHYs

Figure 52 • Clock Path Distribution (Conventional Mode)

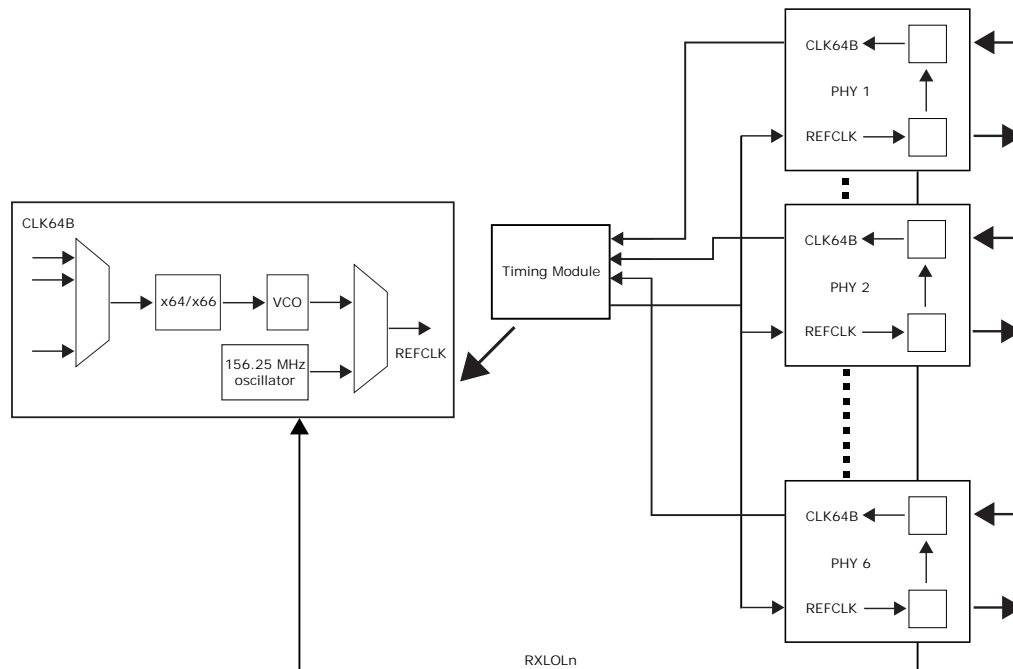

Note: Each PHY is the line card provides a signal to the timing module.

3.13.2 Using Conventional Mode

Use the following recommended procedure for Synchronous Ethernet in conventional mode.

Set register bit 1×E602.5 to high to enable the CLK64B output and set register bits 1×E602.4:3 to 00. These settings enable the CLK64b output and programs the output as a divide-by-64 recovery clock from the XFI input.

1. Before the recovered clock of a particular line card is selected as the REFCLK, complete one of the two steps to notify the timing module that the recovered clock is stabilized and valid for use:
 - Read the Receiver Loss of Lock signal from register bit 2×EF03.12.
 - or
 - Configure the WIS_INTA/B as the LOL indicator by using register bits 2×EF05.12 (WIS_INTA) or 2×EF06.12 (WIS_INTB).
2. Select the corresponding CLK64B output to use as a reference clock when the RXLOL indicates a valid signal from the VSC8486-11 device.
3. Multiply the CLK64B output by 64 and then divide-by-66 to obtain the required 156.25 MHz clock.

REFCLK is used for the transmit clock for the CMU and the hint clock for the CRU inside the VSC8486-11 device. Due to the 156.25 MHz frequency in LAN mode and the 161 MHz frequency of the CLK64B output, this step is required to obtain the necessary 156.25 MHz clock.

4. Provide an external PLL to clean the recovered clock jitter of the VSC8486-11 device.

External PLL allows the REFCLK to use the recovered clock jitter to meet the jitter generation specifications of the XFI. All line cards can now use the clean output clock from the PLL as the REFCLK, which in turn can be used as the Tx clock of the CMU on each PHY. Therefore, the clock that is synchronized to the input data of the selected line card, will be distributed and propagated to other systems.

When using this procedure for Synchronous Ethernet implementation, one consideration is that the REFCLK is needed as the hint clock for the CRU of the PHY and the recovered clock from the CRU is used for the REFCLK for all the line cards including the same PHY. To resolve this dependency, a clock source such as an oscillator is used at start up as the REFCLK to allow the CRU to recover the clock from the XFI input data. Once the recovered clock is available, the external PLL will lock to it and clean up the jitter to provide the REFCLK. The clock source is then switched from the oscillator to this PLL output. The output of the PLL and oscillator must be within 100 ppm to provide an acceptable transient environment.

Another method to resolve this dependency is to use a narrow band PLL that will output 156.25 MHz \pm 100 ppm even if there is no input to the PLL for it to lock on to. When an input is available to lock on, the output of the PLL is frequency locked to the input. Additionally, some PLLs can accept an input of 161 MHz or 156.25 MHz to generate the required 156.25 MHz REFCLK which resolves the frequency matching issue between the CLK64B and the REFCLK.

3.13.3 About Enhanced Mode

The VSC8486-11 device is designed with enhancements that allows for a simplified start up synchronization process that eliminates the need for an external narrow banded PLL and transient period of switching clocks.

This section describes the enhancements that simplify the synchronization process.

3.13.3.1 Reference Clock Source Signals

Separate reference clock source signals are provided for the PMA's CMU, CRU, and for XAUI operation. The following table provides the reference clock source signals and recommendations for Synchronous Ethernet application.

Table 45 • Synchronous Ethernet Reference Clock Source

CRU/CMU/Block	Reference Clock Source	Synchronous Ethernet (Recommended)
CRU of PMA	REFCLK, WREFCLK, and VREFCLK	REFCLK
CMU of PMA	REFCLK, WREFCLK, VREFCLK, and internal recovered clock	REFCLK
XAUI block	REFCLK only	REFCLK only

3.13.3.2 Muxes and Register Bits

Additional muxes and register bits were added to provide additional flexibility in controlling the clock sources to the different blocks of the VSC8486-11 device for Synchronous Ethernet implementation. When 1xE602.2 is high, the register 1xE604.7:0 should be set to one of the following:

10011001: REFCLK = 156.25 MHz, VREFCLK = 161.1328125 MHz.

10011011: REFCLK = 156.25 MHz, VREFCLK = 644.53125 MHz.

10011101: REFCLK = 156.25 MHz, VREFCLK = 156.25 MHz.

The following table lists the added register bits and descriptions for the VSC8486-11 device.

Table 46 • Synchronous Ethernet Register Bits

Register	Bit	Description
1xE602	2	Clock mode override. When this bit is enabled, register 1xE604 can be used to program the clock sources used by the CMU and CRU. 0: Disables the mode override (default). 1: Enables the mode override.
1xE604	7	Clock source for CMU linetime mode when register 1xE602.2 = 1 and linetime mode = 1. 0: Reserved. 1: CMU clock is from the CRU recovered clock. Divided by 64.
	6:5	Clock source to CRU when 1xE602.2 = 2. 00: CRU source clock is from REFCLK. 01: Clock source to CRU is from WREFCLK input. Divided by 64. 1x: Clock source to CRU is from WREFCLK input. Divided by 16.
	4:3	Clock source to CMU when 1xE602.2 = 1. 00: Reserved. 01: Clock source to CMU is from REFCLK input. 10: Clock source to CMU is from internal CRU recovered clock. 11: Clock source to CMU is from VREFCLK input.
	2:1	Provides selection of clock ratio for CMU when register 1xE602.2 = 1. 00: Divided by 64. Only valid when 1xE604.4:3 = 01, 10, 11. 01: Divided by 16. Only valid when 1xE604.4:3 = 01, 10, 11. 1x: Divided by 66. Only valid when 1xE604.4:3 = 00, 01, 10.
	0	Provides selection of clock ratio for CRU when 1xE602.2 = 1. 0: Divided by 64. Only valid when 1xE604.6:5 = 01, 1x. 1: Divided by 66. Only valid when 1xE604.6:5 = 00.

A significant benefit of using Synchronous Ethernet in enhanced mode is the ability to eliminate the transient period that occurs in conventional mode because the REFCLK is needed to recover the clock from the input data. WREFCLK and VREFCLK can be divided by 16, 64, or 66, whereas the REFCLK can only be divided by 66. For improved jitter performance in WAN applications, the VREFCLK divided by 16 is preferred. The recovered CLK64B could be set to a PLL that takes in the CLK64B and provides a 4x CLK64B. A narrow band PLL would no longer be required and the need to adjust a /66 REFCLK from a /64 recovered clock is eliminated. The REFCLK and WREFCLK if needed, can be used as free running clocks from oscillators full time. These features provide a more effective implementation using a common PLL.

Using the REFCLK for both the XAUI block and the clock source for the PMA's CRU, while leaving the WREFCLK unused, provides for a more cost effective solution. The VREFCLK can be selected to be at the same frequency as the CLK64B, for example 161 MHz. A 1:1 PLL is still required to clean up the jitter from CLK64B to the VREFCLK input block. A free running clock source is needed for the PMA's CRU through the REFCLK.

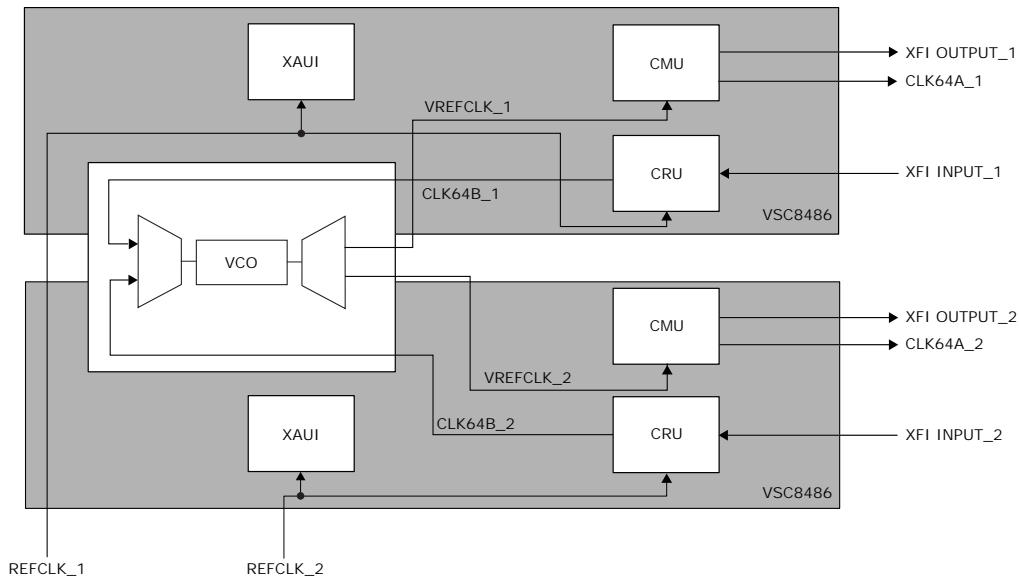
Figure 53 • Synchronous Ethernet Block Diagram

3.13.4 Using Enhanced Mode

The additional MUX register bits and separate clocks that are provided in the VSC8486-11 device lead to the distribution of clock paths and simplifies the start up synchronization process for Synchronous Ethernet operation.

Use the following recommended procedure for Synchronous Ethernet in enhanced mode.

1. Set registers $1 \times E602.2 = 1$, $1 \times E604.6:5 = 0$, and $1 \times E604.0 = 1$. These settings configure a free running oscillator based clock at 156.25 MHz which in turn is used for the XAUI block and the hint clock of the CRU to recover the CLK64B from the XFI input data.
2. Set register bit $1 \times E602.5$ to high to enable the CLK64B output and set register bits $1 \times E602.4:3$ to 00. These settings enable the CLK64b output and programs the output as a divide-by-64 recovery clock from the rate of the XFI input.
 - Before the recovered clock of a particular line card is selected as the REFCLK, complete one of the two steps to notify the timing module that the recovered clock is stabilized and valid for use: Read the Receiver Loss of Lock signal from register bit $2 \times EF03.12$.
 - or
 - Configure the WIS_INTA/B as the LOL indicator by using register bits $2 \times EF05.12$ (WIS_INTA) or $2 \times EF06.12$ (WIS_INTB).
3. Select the corresponding CLK64B output to use as a reference clock when the RXLOL indicates a valid signal from the VSC8486-11 device.
4. Set register bits $1 \times E604.4:3 = 10$ and $1 \times E604.2:1 = 01$. These register settings require a 644 MHz clock which needs to be derived from the CLK64B and requires low jitter.

The PLL output is phase locked to the CLK64B and is distributed to the device on all line cards, which in turn is the VREFCLK that is the transmit clock of the CMU on each PHY. Therefore, the clock that is synchronized to the input data of the selected line card is distributed and propagated to other systems. A free running REFCLK of 156.25 MHz is required for the PHYs.

Figure 54 • Enhanced Mode Distribution of Clock Paths

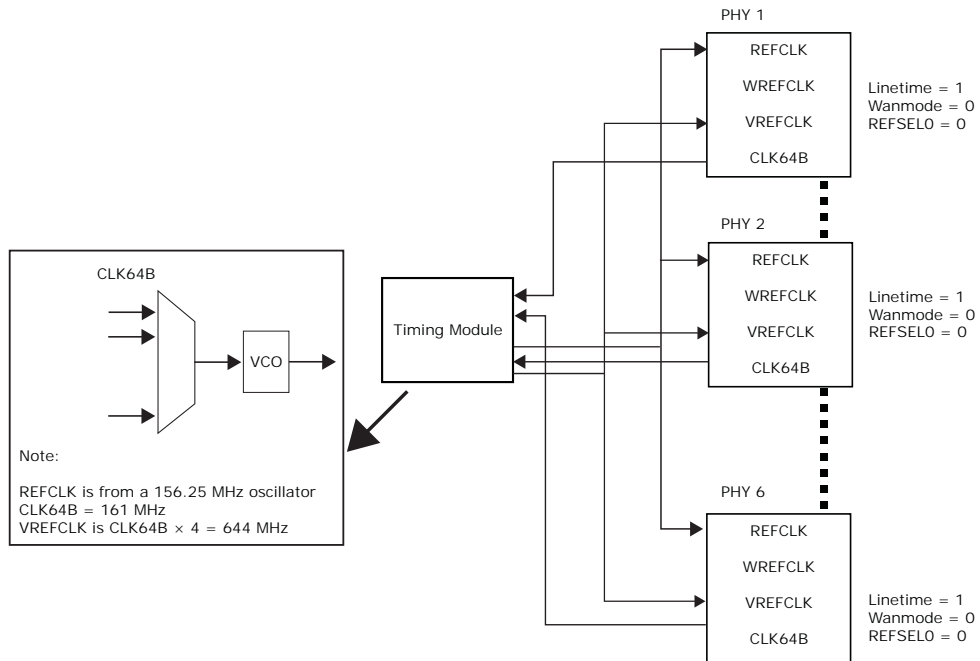

4 Registers

This section describes the registers for the VSC8486-11 device. The registers marked reserved and factory test should not be read or written to, because doing so may produce undesired effects.

The default value documented for registers is based on the value at reset; however, in some cases, that value may change immediately after reset. The access type for each register is shown using the following abbreviations:

- RO: Read Only
- ROCR: Read Only, Clear on Read
- RO/LH: Read Only, Latch High
- RO/LL: Read Only, Latch Low
- RW: Read and Write
- RWSC: Read Write Self Clearing

The registers are organized into the following sections:

- Device 1: PMA Registers, page 89
- Device 2: WIS Registers, page 107
- Device 3: PCS Registers, page 144
- Device 4: PHY-XS Registers, page 157
- Device 30: NVR and DOM Registers, page 170

4.1 Device 1: PMA Registers

The following tables provide settings for the registers related to the PMA.

Table 47 • PMA_CTRL1: PMA Control 1 (1×0000)

Bit	Name	Access	Description	Default
15	SOFT_RST	RWSC	Reset all MMDs. 0: Normal operation. 1: Reset.	0
14	Reserved	RO	Reserved (value always 0, writes ignored).	0
13	SPEED_SEL_A	RO	Indicates whether the device operates at 10 Gbps and above. 0: Unspecified. 1: Operates at 10 Gbps and above.	1
12	Reserved	RO	Reserved (value always 0, writes ignored).	0
11	LOW_PWR	RW	PMA low power mode control. 0: Normal. 1: Low power mode. TXEN is cleared low and everything except MDIO, SPI, and reference clock receiver is disabled.	0
10:7	Reserved	RO	Reserved (value always 0, writes ignored).	0
6	SPEED_SEL_B	RO	Indicates whether the device operates at 10 Gbps and above. 0: Unspecified. 1: Operation at 10 Gbps and above.	1

Table 47 • PMA_CTRL1: PMA Control 1 (1×0000) (continued)

Bit	Name	Access	Description	Default
5:2	SPEED_SEL_C	RO	Speed selection. 1xx: Reserved x1xx: Reserved xx1x: Reserved 0001: Reserved. 0000: 10 Gbps.	0
1	Reserved	RO	Reserved (value always 0, writes ignored).	0
0	LPBK_J_PMA	RW	PMA/WIS system loopback J. 0: Disable. 1: Enable. All zeros output on XFI.	0

Table 48 • PMA_STAT1: PMA Status 1 (1×0001)

Bit	Name	Access	Description	Default
15:8	Reserved	RO	Reserved (ignore when read).	0
7	FAULT	RO	Indicates a fault condition on either the transmit or receive paths. 0: Fault condition not detected. PMA receive local fault (1×0008.10) = 0 and PMA transmit local fault (1×0008.11) = 0. 1: Fault condition detected. PMA receive local fault (1×0008.10) = 1 or PMA transmit local fault (1×0008.11) = 1.	0
6:3	Reserved	RO	Reserved (ignore when read).	0
2	LNK_STAT	RO/LL	Receive link status. 0: PMA receive link down. (RXLOS = 1 and SUPPRESS_RXLOS = 0) or (RXLOCK = 0 and SUPPRESS_RXLOL = 0). 1: PMA receive link up. (RXLOS = 0 or SUPPRESS_RXLOS = 1) and (RXLOCK = 1 or SUPPRESS_RXLOL = 1).	1
1	LOW_PWR_ABILITY	RO	Indicates that MMD supports low power mode. 0: PMA does not support low power mode. 1: PMA supports low power mode.	1
0	Reserved	RO	Reserved (ignore when read).	0

Table 49 • PMA_DEVID1: PMA Device Identifier 1 (1×0002)

Bit	Name	Access	Description	Default
15:0	DEV_ID_MSW	RO	Upper 16 bits of a 32-bit unique PMA device identifier. Bits 3–18 of the device manufacturer's OUI.	0×0007

Table 50 • PMA_DEVID2: PMA Device Identifier 2 (1×0003)

Bit	Name	Access	Description	Default
15:0	DEV_ID_LSW	RO	Lower 16 bits of a 32-bit unique PMA device identifier. Bits 19–24 of the device manufacturer's OUI. Six-bit model number, and a four-bit revision number.	0×0400

Table 51 • PMA_SPEED: PMA Speed Capability (1×0004)

Bit	Name	Access	Description	Default
15:1	Reserved	RO	Reserved for future speeds (value always 0, writes ignored)	0
0	RATE_ABILITY	RO	PMA rate capability 0: Not capable of 10 Gbps 1: Capable of 10 Gbps	1

Table 52 • PMA_DEVPKG1: PMA Devices in Package 1 (1×0005)

Bit	Name	Access	Description	Default
15:6	Reserved	RO	Reserved (ignore when read)	0
5	DTE_XS_PRE	RO	Indicates whether DTE XS is present in the package 0: Not present 1: Present	0
4	PHY_XS_PRE	RO	Indicates whether PHY XS is present in the package 0: Not present 1: Present	1
3	PCS_PRE	RO	Indicates whether PCS is present in the package 0: Not present 1: Present	1
2	WIS_PRE	RO	Indicates whether WIS is present in the package 0: Not present 1: Present	1
1	PMD_PMA_PRES	RO	Indicates whether PMA is present in the package 0: Not present 1: Present	1
0	CLS22_PRE	RO	Indicates whether Clause 22 registers are present in the package 0: Not present 1: Present	0

Table 53 • PMA_DEVPKG2: PMA Devices in Package 2 (1×0006)

Bit	Name	Access	Description	Default
15	VS2_PRES	RO	Vendor specific device 2 present 0: Not present 1: Present	0
14	VS1_PRES	RO	Vendor specific device 1 present 0: Not present 1: Present	0
13:0	Reserved	RO	Reserved (ignore when read)	0

Table 54 • PMA_CTRL2: PMA Control 2 (1×0007)

Bit	Name	Access	Description	Default
15:3	Reserved	RW	Reserved.	0
2:0	PMA_MODE	RW	Indicates the PMA type selected 111: 10GBASE-SR 110: 10GBASE-LR 101: 10GBASE-ER 100: 10GBASE-LX-4 011: 10GBASE-SW 010: 10GBASE-LW 001: 10GBASE-EW 000: Reserved When these bits are set to 10GBASE-SW, 10GBASE-LW or 10GBASE-EW, the WAN mode is enabled.	111

Table 55 • PMA_STAT2: PMA Status 2 (1×0008)

Bit	Name	Access	Description	Default
15:14	DEV_PRES	RO	Reflects the presence of a MMD responding at this address. 00: No device responding at this address. 01: No device responding at this address. 10: Device responding at this address. 11: No device responding at this address.	10
13	FAULT_TX_ABILITY	RO	Indicates a fault condition on the transmit path. 0: PMA does not have the ability to detect a fault condition on the transmit path. 1: PMA has the ability to detect a fault condition on the transmit path.	1
12	FAULT_RX_ABILITY	RO	Indicates a fault condition on the receive path. 0: PMA does not have the ability to detect a fault condition on the receive path. 1: PMA has the ability to detect a fault condition on the receive path.	1

Table 55 • PMA_STAT2: PMA Status 2 (1×0008) (continued)

Bit	Name	Access	Description	Default
11	FAULT_TX	RO/LH	Indicates a fault condition on the transmit path. 0: No faults asserted. TXFAULT = 0 and TXLOCK = 1. 1: Fault asserted. TXFAULT = 1 or TXLOCK = 0. Linked to 1E×9004.4. A read to either 1×0008.11 or 1E×9004.4 clears both bits if the fault condition no longer exists.	0
10	FAULT_RX	RO/LH	Indicates a fault condition on the receive path. 0: No faults asserted. (RXLOS = 0 or SUPPRESS_RXLOS = 1) and (RXLOCK = 1 or SUPPRESS_RXLOL = 1). 1: Fault asserted. (RXLOS = 1 and SUPPRESS_RXLOS = 0) or (RXLOCK = 0 and SUPPRESS_RXLOL = 0). Linked to 1E×9003.4. A read to either 1×0008.10 or 1E×9003.4 clears both bits if the fault condition no longer exists.	0
9	Reserved	RO	Reserved (ignore when read).	0
8	TXDIS_ABILITY	RO	Device capability to disable the transmit path. 0: Not capable. 1: Capable. To disable PMD, use GPO_TXALARM (1×E901.8). Transmit output of the VSC8486-11 device is disabled by means of 1×0000.11 or 1×E605.9:8.	0
7	BASE_SR_ABILITY	RO	Device capability to support 10GBASE-SR. 0: Not capable. 1: Capable.	1
6	BASE_LR_ABILITY	RO	Device capability to support 10GBASE-LR. 0: Not capable. 1: Capable.	1
5	BASE_ER_ABILITY	RO	Device capability to support 10GBASE-ER. 0: Not capable. 1: Capable.	1
4	BASE_LX4_ABILITY	RO	Device capability to support 10GBASE-LX4. 0: Not capable. 1: Capable.	0
3	BASE_SW_ABILITY	RO	Device capability to support 10GBASE-SW. 0: Not capable. 1: Capable.	1
2	BASE_LW_ABILITY	RO	Device capability to support 10GBASE-LW. 0: Not capable. 1: Capable.	1
1	BASE_EW_ABILITY	RO	Device capability to support 10GBASE-EW. 0: Not capable. 1: Capable.	1
0	PMA_LPBK_ABILITY	RO	Device capability to support a PMA loopback. 0: Not capable. 1: Capable.	1

Table 56 • PMA_CTRL3: PMA Control 3 (1×0009)

Bit	Name	Access	Description	Default
15:1	Reserved	RO	Reserved (value always 0, writes ignored).	0
0	TX_DIS	RW	Not supported. To disable the transmit output, use the low power mode (1×0000.11), or the TxOnOff override and force bits 1×E605.9:8. Additionally, the PMD transmitter output can be disabled by using the GPO_TXALARM (1×E901.8).	0

Table 57 • PMA_STAT3: PMA Status 3 (1×000A)

Bit	Name	Access	Description	Default
15:1	Reserved	RO	Reserved (value always 0, writes ignored).	0
0	RX_SD	RO	Receive signal detected. 0: Signal not detected. (RXLOS = 1 and SUPPRESS_RXLOS = 0). 1: Signal detected. (RXLOS = 0 or SUPPRESS_RXLOS = 1).	0

Table 58 • Factory Test Register (1×000B–000D)

Bit	Name	Access	Description	Default
15:0	Reserved	RO	Factory test only; do not modify	0

Table 59 • PMA_PKGID1: PMA Package Identifier 1 (1×000E)

Bit	Name	Access	Description	Default
15:0	PKG_ID_MSW	RO	Upper 16 bits of a 32-bit unique PMA package identifier. Bits 3–18 of the device manufacturer's OUI.	0

Table 60 • PMA_PKGID2: PMA Package Identifier 2 (1×000F)

Bit	Name	Access	Description	Default
15:0	PKG_ID_LSW	RO	Lower 16 bits of a 32-bit unique PMA package identifier. Bits 19–24 of the device manufacturer's OUI. Six-bit model number, and a four-bit revision number.	0

Table 61 • PMA_CFG1: PMA Configuration 1 (1×8000)

Bit	Name	Access	Description	Default
15:14	CRU_LOOP_BANDWIDT H [1:0]	RW	CRU loop bandwidth adjustment 00: ~10 MHz 01: ~13 MHz 10: ~16 MHz 11: ~19 MHz	10
13	RX_SQU_MAN_EN	RW	Rx_SQUELCHING manual mode enable. 0: Enable 1: Disable For more information, see Table 66 , page 97.	1
12	Reserved	RO	Factory test only; do not modify	1
11	Reserved	RO	Factory test only; do not modify	0
10	Reserved	RWSC	Factory test only; do not modify	1
9	Reserved	RW	Factory test only; do not modify	0
8	LPBKN_K	RW	Disable PMA serial loopback (loopback K) 0: Enable 1: Disable	1
7	TX_DATAINVN	RW	Selects polarity of the transmit XFI/SFI data 0: Invert Tx data polarity 1: Normal operation	1
6	TX_MSBSEL	RW	Selects the transmission bit order 0: MSB transmitted first with bit 63 being the MSB 1: LSB transmitted first with bit 0 being the MSB (IEEE style)	1
5	Reserved	RW	Factory test only; do not modify	0
4	Reserved	RW	Factory test only; do not modify	1
3	RX_LOSDATASQN	RW	Selects data squelch mode (See Lock to Reference Table within the text) 0: Automatic data squelch mode 1: Manual data squelch mode	1
2	RX_LCKREFN	RW	Selects Lock to Reference (See Lock to Reference Table within the text) 0: Lock to Refclk (squelch data) 1: Normal operation	1
1	RX_DATAINVN	RW	Selects polarity of the receive XFI/SFI data 0: Invert Rx data polarity 1: Normal operation	1
0	RX_MSBSELN	RW	Selects the receive bit order 0: MSB received first with bit 63 being the MSB 1: LSB received first with bit 0 being the MSB (IEEE style)	1

Table 62 • Factory Test Register (1×8001)

Bit	Name	Access	Description	Default
15:1	Reserved	RO	Reserved (ignore when read)	0
0	Reserved	RO	Factory test only; do not modify	1

Table 63 • PMA_RXEQ_CTRL: PMA Rx Equalization Control (1×8002)

Bit	Name	Access	Description	Default
15	Reserved	RO	Factory test only; do not modify	1
14:11	RX_EQ_CTRL	RW	Amount of receive signal equalization	1111
10:0	Reserved	RO	Factory test only; do not modify	101010101

Table 64 • PMA_STAT4: PMA Status 4 (1×E600)

Bit	Name	Access	Description	Default
15:4	Reserved	RO	Reserved (ignore when read)	0
3	Reserved	RO	Factory test only; do not modify	1
2	TXLOCKERRN	RO	Transmit clock multiplier lock error status 0: Lock error 1: Normal operation	1
1	RXLOCKERRN	RO	Receive clock recovery lock error status 0: Lock error 1: Normal operation	1
0	RXLOS	RO	Receiver loss of signal status 0: Loss of signal 1: Normal operation	N/A ¹

1. The status of this bit changes and is dependent on the condition of the connected PMD.

Table 65 • PMA_CTRL4: PMA Control 4 (1×E601)

Bit	Name	Access	Description	Default
15:8	Reserved	RO	Factory test only; do not modify	10101010

Table 65 • PMA_CTRL4: PMA Control 4 (1×E601) (continued)

Bit	Name	Access	Description	Default
7:4	TX_EMPH_SEL	RW	Amount of PMA transmit pre-emphasis Type 1 0000: 1.8 dB (default) 0100: 2.7 dB 1000: 3.3 dB 1111: 3.9 dB Type 2 0000: 3.8 dB 0100: 4.8 dB 1000: 6.2 dB 1111: 6.4 dB	0
3:0	TX_SLEW_SEL	RW	Amount of PMA transmit slew rate 0000: Type 1 1111: Type 2 all others: Reserved	0

Table 66 • PMA_CTRL5: PMA Control 5 (1×E602)

Bit	Name	Access	Description	Default
15	TX_SQUELCH	RW	Enables transmit data squelch. Force all zeros out the serial interface 0: Disable 1: Enable	0
14	RX_SQUELCH	RW	Enables received data squelch. Forces all zeros into the core. 0: Disable 1: Enable To enable the RX_SQUELCH manually, register 1×8000.13 must be set to 0. Otherwise, the default setting is to squelch the RX output automatically. For more information, see Table 61 , page 95.	0
13:10	Reserved	RW	Factory test only; do not modify	0
9	CLK64A_ENA	RW	Enables the CLK64A output signal. This signal is used when CLK64A_SRC is asserted. 0: Disable 1: Enable	0
8:7	CLK64A_SEL	RW	Selects which internal clock signal to output on CLK64A 00: CMU divided by 64 01: CMU divided by 66 10: CRU divided by 64 11: REFCK	0
6	CLK64A_SRC	RW	Selects the source of the CLK64_EN signal 0: Enables CLK64A through the CLK64_EN pin 1: Enables CLK64A through the CLK64A_ENA (1×E602.9)	0
5	CLK64B_ENA	RW	Enables the CLK64B output 0: Disable 1: Enable	0

Table 66 • PMA_CTRL5: PMA Control 5 (1×E602) (continued)

Bit	Name	Access	Description	Default
4:3	CLK64B_SEL	RW	Selects which internal clock signal to output on CLK64B 00: CRU divided by 64 01: CMU divided by 66 10: CMU divided by 64 11: Factory test	0
2	SYNC_E	RW	Enables mode override for Synchronous Ethernet application. Enabling this bit allows usage of the REFCLK, WREFCLK, and VREFCLK clocks for the XAUI, CMU, and CRU blocks separately in LAN mode. For more information, see register Table 68 , page 98.	0
1:0	Reserved	RO	Reserved (value always 0, writes ignored)	0

Table 67 • High-Speed Data Output (Signal Quality Control) (1×E603)

Bit	Name	Access	Description	Default
15:8	OUT_DEMP	R/W	Output de-emphasis adjustment. 00000000: Minimum de-emphasis. 11111111: Maximum de-emphasis. Values in between are not linear.	0
7:0	OUT_SWING	R/W	Output swing adjustment. 00000000: Minimum swing. 11111111: Maximum swing. Values in between are not linear.	0

Table 68 • Synchronous Ethernet Clock Control (1×E604)

Bit	Name	Access	Description	Default
15	GAIN_SEL	R/W	XFI input gain factor select. 0: Enable high gain factor. 1: Enable low gain factor. Low gain factor is similar to the low gain factor in VSC8476-01 device. Note: For applications that do not require high input gain, set this bit to 1 for optimal jitter tolerance.	0
14:8	Reserved	R/W	Reserved.	0
7	CMU_INTCLK_EN	R/W	CMU clock source. 0: Reserved 1: CMU REFCLK is from internal CRU recovered clock divided by 64.	0

Table 68 • Synchronous Ethernet Clock Control (1×E604) (continued)

Bit	Name	Access	Description	Default
6:5	CRU_CLKSEL	R/W	CRU clock source. 00: CRU source clock is from REFCLK. 01: CRU source clock is from WREFCLK divided by 64. 10: CRU source clock is from WREFCLK divided by 16. 11: Reserved.	0
4:3	CMU_CLKSEL	R/W	CMU clock source. 00: Reserved. 01: CMU source clock is from REFCLK. 10: CMU source clock is from internal CRU recovered clock and bit 7 needs to be set to 1. 11: CMU source clock is from VREFCLK.	0
2:1	CMUCLK_DVDR	R/W	Divider for CMU clock. 00: CMU source clock is divided by 64. 01: CMU source clock is divided by 16. 1x: CMU source clock is divided by 66.	0
0	CRUCLK_DVDR	R/W	Divider for CRU clock 0: CRU source clock is divided by 64. 1: CRU source clock is divided by 66.	0

Table 69 • DEV_CTRL3: DEVICE Control 3 (1×E605)

Bit	Name	Access	Description	Default
15	WIS_INTB_POL	RW	Active level (polarity) used for the output pin, WIS_INTB 0: Active low 1: Active high	0
14	WIS_INTA_POL	RW	Active level (polarity) used for the output pin, WIS_INTA 0: Active low 1: Active high	0
13	AUTONEG_OVR	RW	Enables overriding the input pin value and instead use the force bit setting 0: Use the AUTONEG input pin state 1: Override enable	0
12	AUTONEG_FRC	RW	Value to be used if the override bit is enabled 0: If AUTONEG_OVR = 1, AUTONEG = 0 1: If AUTONEG_OVR = 1, AUTONEG = 1	0
11	EPCS_OVR	RW	Enables overriding the input pin value and instead use the force bit setting 0: Use the EPCS input pin state 1: Override enable	0
10	EPCS_FRC	RW	Value to be used if the override bit is enabled 0: If EPCS_OVR = 1, EPCS = 0 1: If EPCS_OVR = 1, EPCS = 1	0

Table 69 • DEV_CTRL3: DEVICE Control 3 (1×E605) (continued)

Bit	Name	Access	Description	Default
9	TXONOFF_OVR	RW	Enables overriding the input pin value and instead use the force bit setting 0: Use the TXONOFF pin state 1: Use the TXONOFF_FRC value when TXONOFF pin = low. Note: The TXONOFF pin must be set high for register bits 9:8 to override the transmit output.	0
8	TXONOFF_FRC	RW	Value to be used if the override bit is enabled 0: If TXONOFF_OVR = 1, TXONOFF = 0 1: If TXONOFF_OVR = 1, TXONOFF = 1 Note: The TXONOFF pin must be set high for register bits 9:8 to override the transmit output.	0
7	REFSEL0_OVR	RW	Enables overriding the input pin value and instead use the force bit setting 0: Use the REFSEL0 input pin state 1: Override enable	0
6	REFSEL0_FRC	RW	Value to be used if the override bit is enabled 0: If REFSEL0_OVR = 1, REFSEL0 = 0 1: If REFSEL0_OVR = 1, REFSEL0 = 1	0
5	Reserved	RO	Reserved (ignored when read)	0
4	LINETIME_FRC	RW	Force the device into linetime mode 0: Normal operation 1: Linetime enable	0
3	WAN_OVR	RW	Enables overriding the input pin value and instead use the force bit setting 0: Use the WAN input pin state 1: Override enable	0
2	WAN_FRC	RW	Value to be used if the override bit is enabled 0: If WAN_OVR = 1, WAN is disabled regardless of any other control setting 1: If WAN_OVR = 1, WAN is enabled regardless of any other control setting	0
1	SUPPRESS_RXLOL	RW	Disable receive LOL status from propagating into the fault logic 0: Receive LOL signal is used for fault logic 1: Receive LOL signal is ignored by fault logic	0
0	SUPPRESS_RXLOS	RW	Disable receive LOS status from propagating into the fault logic 0: Receive LOS signal is used for fault logic 1: Receive LOS signal is ignored by fault logic	0

Table 70 • DEV_STAT1: DEVICE Status 1 (1×E606)

Bit	Name	Access	Description	Default
15	WAN_STAT	RO	Status of WAN mode 0: Disabled 1: Enabled	0

Table 70 • DEV_STAT1: DEVICE Status 1 (1×E606) (continued)

Bit	Name	Access	Description	Default
14	WAN_MODE_PSTAT	RO	Input level received on the WAN_MODE pin 0: Low 1: High	0
13	LINETIME_STAT	RO	Current state of the linetime signal 0: Low 1: High	0
12	REFSEL0_PSTAT	RO	Input level received on the REFSEL0 pin 0: Low 1: High	0
11	LPP_10B_PSTAT	RO	Input level received on the LPP_10B pin 0: Low 1: High	0
10	Reserved	RO	Factory test only; do not modify	0
9	SPLITLOOPN_PSTAT	RO	Input level received on the SPLITLOOPN pin 0: Low 1: High	0
8	Reserved	RO	Factory use only; do not modify	0
7	LP_16B_PSTAT	RO	Input level received on the LP_16B pin 0: Low 1: High	0
6	Reserved	RO	Factory use only; do not modify	0
5	AUTONEG_PSTAT	RO	Input level received on the AUTONEG pin 0: Low 1: High	0
4	EPCS_PSTAT	RO	Input level received on the EPCS pin 0: Low 1: High	0
3:0	Reserved	RO	Factory test only; do not modify	0

Table 71 • DEV_STAT2: DEVICE Status 2 (1×E607)

Bit	Name	Access	Description	Default
15:13	MST_CODE_PSTAT	RO	Received signal levels of the MST_CODE[2:0] input pins.	0
12:7	Reserved	RO	Factory test only; do not modify.	0
6	EPCS_PSTAT	RO	Input level received on the EPCS pin. 0: Low. 1: High.	0
5	AUTONEG_PSTAT	RO	Input level received on the AUTONEG pin. 0: Low. 1: High.	0
4	FORCEAIS_PSTAT	RO	Input level received on the FORCEAIS pin. 0: Low. 1: High.	0

Table 71 • DEV_STAT2: DEVICE Status 2 (1×E607) (continued)

Bit	Name	Access	Description	Default
3	WIS_INTA_PSTAT	RO	Output level sent on the WIS_INTA pin. 0: Low. 1: High.	0
2	WIS_INTB_PSTAT	RO	Output level sent on the WIS_INTB pin. 0: Low. 1: High.	0
1	PMTICK_PSTAT	RO	Input level received on the TESTEN pin. 0: Low. 1: High.	0
0	LOPC_PSTAT	RO	Input level received on the LOPC pin. 0: Low. 1: High.	0

Table 72 • PMA_LOS_ASSERT: PMA Loss of Signal Assert Control (1×E700)

Bit	Name	Access	Description	Default
15:10	Reserved	RO	Reserved.	0
9:7	Reserved	RW	Factory test only; do not modify.	0
6	LOS_MODE_SEL	RW	Selects which style of LOS monitoring to use. 0: Monitor LOS at the input. 1: Monitor LSO after signal cleanup. Must be 0 for correct sensitivity performance in the VSC8486-11.	0
5:0	LOS_ASSERT_DA C	RW	Set the LOS assert voltage threshold. 001100: Less than 75 mV. 010010: Greater than 110 mV. All else: Reserved.	0

Table 73 • PMA_LOS_DEASSERT: PMA Loss of Signal Deassert Control (1×E701)

Bit	Name	Access	Description	Default
15	LOS_EN	RW	Enables LOS circuitry. 0: Enable PMA LOS. 1: Disable PMA LOS.	1
14:12	LOS_WIN	RW	LOS report/clear time setting.	0
11:8	VCM_ADJ	RW	Input receiver common mode voltage adjust. Observable on RXINCM (pin N3).	1000
7:6	Reserved	RW	Factory test only; do not modify.	0
5:0	LOS_DEASSERT_DA C	RW	Set the LOS deassert voltage threshold. 001100: Less than 75 mV. 010010: Greater than 110 mV. All else: Reserved.	0

Table 74 • PMA_LOS_STAT: PMA Loss of Signal Status (1×E702)

Bit	Name	Access	Description	Default
15:3	Reserved	RO	Reserved	0
2	LOS_ASSERT_STAT	RO	Assert comparison (see also 1×E700.5:0) 0: Assert threshold is less than peak detector monitor 1: Assert threshold is greater than peak detector monitor	N/ ¹
1	LOS_DEASSERT_STAT	RO	Deassert comparison (see also 1×E701.5:0) 0: Deassert threshold is less than peak detector monitor 1: Deassert threshold is greater than peak detector monitor	N/A ¹
0	LOS_STAT	RO	Loss of signal status (identical to 1×E600.0) 0: Loss of signal 1: Normal operation	N/A ¹

1. The status of this bit changes and is dependent on the condition of the connected PMD.

Table 75 • DEV_ID: DEVICE Identifier (1×E800)

Bit	Name	Access	Description	Default
15:0	CHIP_ID	RO	Contains the identification number of the chip	0×8486

Table 76 • DEV_REV: DEVICE Revision (1×E801)

Bit	Name	Access	Description	Default
15:0	CHIP_REV	RO	Contains the revision number of the chip	0×0003

Table 77 • Factory Test Register (1×E900)

Bit	Name	Access	Description	Default
15:0	Reserved	RO	Factory test only; do not modify	0

Table 78 • DEV_GPIO_CTRL: DEVICE General Purpose I/O Control (1×E901)

Bit	Name	Access	Description	Default
15	Reserved	RO	Reserved (value always 0, writes ignored)	0
14:13	TXALARM_SEL	RW	Selects source of TXALARM output 00: Normal TXALARM 01: Tx link/activity LED 10: GPO mode 11: Reserved	0

Table 78 • DEV_GPIO_CTRL: DEVICE General Purpose I/O Control (1×E901) (continued)

Bit	Name	Access	Description	Default
12:11	RXALARM_SEL	RW	Selects source of RXALARM output 00: Normal RXALARM 01: Rx link/activity LED 10: GPO mode 11: Reserved	0
10	LASI_SEL	RW	Selects source of LASI output 0: Normal LASI output 1: GPO mode	0
9	WIS_INTB_SEL	RW	Selects source of WIS_INTB output 0: XFP module reset or SFP+ TXDISABLE 1: WIS interrupt B function	0
8	GPO_TXALARM	RW	Transmitted on TXALARM when in GPO mode	0
7	GPO_RXALARM	RW	Transmitted on RXALARM when in GPO mode	0
6	GPO_LASI	RW	Transmitted on LASI when in GPO mode	0
5	TX_LED_BLINK_TIME	RW	Tx data activity LED blink time 0: 50 ms interval 1: 100 ms interval	1
4	RX_LED_BLINK_TIME	RW	Rx data activity LED blink time 0: 50 ms interval 1: 100 ms interval	1
3:2	TX_LED_MODE	RW	00: Display Tx link status (XAUI mode) 01: Display Tx data activity status 10: Display combination of link and data activity status (XAUI mode) 11: Reserved	10
1:0	RX_LED_MODE	RW	Rx LED mode control 00: Display Rx link status 01: Display Rx data activity status 10: Display combo of link and data activity status 11: Reserved	10

Table 79 • DEV_XFP_CTRL: DEVICE XFP Control (1×E902)

Bit	Name	Access	Description	Default
15:3	Reserved	RO	Reserved (value always 0, writes ignored)	0
2	XFP_RST_ON_LOWPWR or SFP+_Tx_DIS	RW	XFP Select for XFP reset on low power mode 0: No low power mode contribution to XFP reset 1: XFP reset in low power mode SFP+ Select for Tx_DIS 0: SFP+ module functioning regardless of no low power mode 1: Disables SFP+ module in low power mode	1

Table 79 • DEV_XFP_CTRL: DEVICE XFP Control (1×E902) (continued)

Bit	Name	Access	Description	Default
1	XFP_RST_INV or SFP+_Tx_DIS_INV	RW	XFP Invert XFP reset state on WIS_INTB 0: Active high 1: Active low SFP+ Invert SFP+ Tx_DIS state on WIS_INTB 0: Active high 1: Active low	0
0	XFP_RST or SFP+_DIS	RW	XFP Force XFP power-down reset 0: Normal operation 1: Hold in power down reset state SFP+ Force SFP+ transmit to be disabled 0: Normal operation 1: Hold the SFP+ transmit in disable state	0

Table 80 • Factory Test Register (1×EC00)

Bit	Name	Access	Description	Default
15:0	TEST	RW	Factory test only; do not modify	0

Table 81 • Factory Test (1×EC01–EC34)

Bit	Name	Access	Description	Default
15:0	Reserved	RO	Reserved (value always 0, writes ignored)	0

Table 82 • Factory Test (1×ED00–ED0F)

Bit	Name	Access	Description	Default
15:0	TEST	RW	Factory test only; do not modify	0

Table 83 • Factory Test Register (1×EF00)

Bit	Name	Access	Description	Default
15:0	TEST	RO	Factory test only; do not modify	0

Table 84 • DEV_RST_CTRL: DEVICE Block Reset Control (1×EF01)

Bit	Name	Access	Description	Default
15	STW_CTRL_RST	RWSC	A block level software reset for the two-wire serial controller.	0
14:9	Reserved	RW	Reserved	0

Table 84 • DEV_RST_CTRL: DEVICE Block Reset Control (1×EF01) (continued)

Bit	Name	Access	Description	Default
8	RST_WIS_TX	RWSC	Reset the WIS Tx path 0: Normal operation 1: WIS Tx path reset	0
7	RST_WIS_TXFIFO	RWSC	Reset the Tx WIS FIFO 0: Normal operation 1: Tx WIS FIFO reset	0
6	RST_WIS_TXFIFOPTR	RWSC	Reset the Tx WIS FIFO pointers 0: Normal operation 1: Tx WIS FIFO pointer reset	0
5	RST_WIS_INTR	RWSC	Reset the WIS interrupt tree 0: Normal operation 1: Reset WIS interrupt tree	0
4	RST_WIS_RXFIFO	RWSC	Reset the Rx WIS FIFO 0: Normal operation 1: Rx WIS FIFO reset	0
3	RST_WIS_RX	RWSC	Reset the WIS Rx path 0: Normal operation 1: WIS Rx path reset	0
2	RST_PCS_TX	RWSC	Reset the PCS Tx path 0: Normal operation 1: PCS Tx path reset	0
1	RST_PCS_RX	RWSC	Reset the PCS Rx path 0: Normal operation 1: PCS Rx path reset	0
0	RST_XGXS_FIFO	RWSC	Reset the XGXS FIFO 0: Normal operation 1: XGXS FIFO reset	0

Table 85 • DEV_XFI_CTRL2: DEVICE XFI Loopback Control 2 (1×EF10)

Bit	Name	Access	Description	Default
15:3	Reserved	RO	Reserved (value always 0, writes ignored)	0
2	XFI_LPBK_OVR	RW	Override the default data pattern to transmit out the XFI port while in loopback 0: Normal operation 1: Override XFI transmit data according to bits 1:0.	0
1:0	XFI_TXDATA_SEL	RW	Selects the data pattern to transmit out the XFI port while in loopback 00: 0×00FF repeating pattern 01: All zeros 10: All ones 11: Tx data from WIS/PCS	0

4.2 Device 2: WIS Registers

The following tables provide settings for the registers related to WIS.

Table 86 • WIS_CTRL1: WIS Control 1 (2×0000)

Bit	Name	Access	Description	Default
15	SOFT_RST	RWSC	Reset all MMDs. 0: Normal operation. 1: Reset.	0
14	LPBK_J	RW	Enables WIS system loopback (loopback J). 0: Disable. 1: Enable.	0
13	SPEED_SEL_A	RO	WIS speed capability. 0: Unspecified. 1: Operates at 10 Gbps or above.	1
12	Reserved	RO	Reserved.	0
11	LOW_PWR	RW	Enter low power mode. 0: Normal operation. 1: Low power mode. The XAUI and PMA high-speed output driver are disabled. TXEN is active to indicate low power state. Register bit TXEN_INV (1×E602.12) selects whether TXEN is active high or low.	0
10:7	Reserved	RO	Reserved.	0
6	SPEED_SEL_B	RO	WIS speed capability. 0: Unspecified. 1: Operates at 10 Gbps or above.	1
5:2	SPEED_SEL_C	RO	WIS speed selection. 1xx: Reserved. x1x: Reserved. xx1x: Reserved. 0001: Reserved. 0000: 10 Gbps.	0
1:0	Reserved	RO	Reserved.	0

Table 87 • WIS_STAT1: WIS Status 1 (2×0001)

Bit	Name	Access	Description	Default
15:8	Reserved	RO	Reserved.	0
7	FAULT	RO	0: No faults asserted. 1: Fault asserted. For more information about the cause of the fault, see Table 174 , page 143.	0
6:3	Reserved	RO	Reserved.	0

Table 87 • WIS_STAT1: WIS Status 1 (2×0001) (continued)

Bit	Name	Access	Description	Default
2	LNK_STAT	RO/LL	WIS receive link status. Link up means no AIS-P, AIS-L, PLM-P, or SEF alarms. 0: Link down. 1: Link up. Link up: AIS-P = 0 and AIS-L = 0 and PLM-P = 0 and WIS SEF = 0. WIS link down: AIS-P = 1 or AIS-L = 1 or PLM-P = 1 or WIS SEF = 1.	1
1	LOW_PWR_ABILITY	RO	Low power mode support ability. 0: Not supported. 1: Supported.	1
0	Reserved	RO	Reserved.	0

Table 88 • WIS_DEVID1: WIS Device Identifier 1 (2×0002)

Bit	Name	Access	Description	Default
15:0	DEV_ID_MSW	RO	Upper 16 bits of a 32-bit unique WIS device identifier. Bits 3–18 of the device manufacturer's OUI.	0×0007

Table 89 • WIS_DEVID2: WIS Device Identifier 2 (2×0003)

Bit	Name	Access	Description	Default
15:0	DEV_ID_LSW	RO	Lower 16 bits of a 32-bit unique WIS device identifier. Bits 19–24 of the device manufacturer's OUI. Six-bit model number, and a four-bit revision number.	0×0400

Table 90 • WIS_SPEED: WIS Speed Capability (2×0004)

Bit	Name	Access	Description	Default
15:1	Reserved	RO	Reserved	0
0	RATE_ABILITY	RO	WIS rate capability 0: Not capable of 10 Gbps 1: Capable of 10 Gbps	1

Table 91 • WIS_DEVPKG1: WIS Devices in Package 1 (2×0005)

Bit	Name	Access	Description	Default
15:6	Reserved	RO	Reserved	0
5	DTE_XS_PRESENT	RO	Indicates whether DTE XS is present in the package 0: Not present 1: Present	0

Table 91 • WIS_DEVPKG1: WIS Devices in Package 1 (2×0005) (continued)

Bit	Name	Access	Description	Default
4	PHY_XS_PRES	RO	Indicates whether PHY XS is present in the package 0: Not present 1: Present	1
3	PCS_PRES	RO	Indicates whether PCS is present in the package 0: Not present 1: Present	1
2	WIS_PRES	RO	Indicates whether WIS is present in the package 0: Not present 1: Present	1
1	PMD_PMA_PRES	RO	Indicates whether PMA/PMD is present in the package 0: Not present 1: Present	1
0	CLS22_PRES	RO	Indicates whether Clause 22 registers are present in the package 0: Not present 1: Present	0

Table 92 • WIS_DEVPKG2: WIS Devices in Package 2 (2×0006)

Bit	Name	Access	Description	Default
15	VS2_PRES	RO	Vendor specific device 2 present 0: Not present 1: Present	0
14	VS1_PRES	RO	Vendor specific device 1 present 0: Not present 1: Present	0
13:0	Reserved	RO	Reserved	0

Table 93 • WIS_CTRL2: WIS Control 2 (2×0007)

Bit	Name	Access	Description	Default
15:6	Reserved	RO	Reserved.	0
5	TEST_PRBS31_ANA	RW	Enables WIS PRBS31 test pattern checking function. 0: Disabled. 1: Enabled.	0
4	TEST_PRBS31_GEN	RW	Enables WIS PRBS31 test pattern generation function. 0: Disable. 1: Enable.	0
3	TEST_PAT_SEL	RW	Selects the pattern type sent by the transmitter when TEST_PAT_GEN (2×0007.1) is low. 0: Mixed frequency test pattern. 1: Square wave.	0

Table 93 • WIS_CTRL2: WIS Control 2 (2×0007) (continued)

Bit	Name	Access	Description	Default
2	TEST_PAT_ANA	RW	Enables the WIS test pattern checker. Doing so prevents the loss of code-group delineation (LCD-P) alarm from being set while the WIS is receiving the mixed frequency test pattern. 0: Disable. 1: Enable.	0
1	TEST_PAT_GEN	RW	Enables WIS test pattern generation. 0: Disable. 1: Enable.	0
0	WAN_MODE	RW	Enables 10GBASE-W logic and sets the speed of the WIS-PMA interface to 9.95328 Gbps. The proper reference clock frequency must be provided to set the data rate. There are multiple ways to enable WAN mode. 0: Disable. 1: Enable.	0

Table 94 • WIS_STAT2: WIS Status 2 (2×0008)

Bit	Name	Access	Description	Default
15:14	DEV_PRES	RO	Reflects the presence of a MMD responding at this address 00: No device responding at this address 01: No device responding at this address 10: Device responding at this address 11: No device responding at this address	10
13:2	Reserved	RO	Reserved	0
1	PRBS31_ABILITY	RO	Indicates if WIS supports PRBS31 pattern testing 0: Not supported 1: Supported	1
0	BASE_R_ABILITY	RO	Indicates if WIS supports a bypass to allow support of 10GBASE-R 0: Not supported 1: Supported	1

Table 95 • WIS_TSTPAT_CNT: WIS Test Pattern Error Counter (2×0009)

Bit	Name	Access	Description	Default
15:0	TSTPAT_CNT	ROCR	PRBS31 test pattern error counter. The saturating counter clears on read. The error count is not valid until the SYNC bit in 2×EC51.0 is asserted. The error count can be incremented while the checker is acquiring sync. To clear the invalid error count when sync is achieved, read 2×0009. After the counter begins to increment, the counting is not affected by changes to the pattern synchronization.	0

Table 96 • WIS_PKGID1: WIS Package Identifier 1 (2×000E)

Bit	Name	Access	Description	Default
15:0	PKG_ID_MSW	RO	Upper 16 bits of a 32-bit unique WIS package identifier. Bits 3–18 of the device manufacturer's OUI. Six-bit model number and a four-bit revision number.	0

Table 97 • WIS_PKGID2: WIS Package Identifier 2 (2×000F)

Bit	Name	Access	Description	Default
15:0	PKG_ID_LSW	RO	Lower 16 bits of a 32-bit unique WIS package identifier. Bits 19–24 of the device manufacturer's OUI. Six-bit model number and a four-bit revision number.	0

Table 98 • WIS_STAT3: WIS Status 3 (2×0021)

Bit	Name	Access	Description	Default
15:12	Reserved	RO	Reserved	0
11	SEF	RO/LH	Severely errored frame 0: No SEF detected 1: SEF detected	0
10	FEPLMP_LCD P	RO/LH	Indicates far-end PLM-P/LCD-P defect in WIS Rx 0: No far-end path label mismatch/loss of code-group delineation 1: Far-end path label mismatch/loss of code-group delineation	0
9	FEAISP_LOPP	RO/LH	Indicates far-end AIS-P/LOP-P defect in WIS Rx 0: Far-end path alarm indication signal/path loss of pointer 1: No far-end path alarm indication signal/path loss of pointer	0
8	Reserved	RO	Reserved	0
7	LOF	RO/LH	Loss of frame 0: Loss of frame flag lowered 1: Loss of frame flag raised	0
6	LOS	RO/LH	Loss of signal 0: Loss of signal flag lowered 1: Loss of signal flag raised	0
5	RDIL	RO/LH	Line remote defect indication 0: Line remote defect flag lowered 1: Line remote defect flag raised	0
4	AISL	RO/LH	Line alarm indication signal 0: Line alarm indication flag lowered 1: Line alarm indication flag raised	0
3	LCDP	RO/LH	Path loss of code-group delineation 0: Path loss of code-group delineation flag lowered 1: Path loss of code-group delineation flag raised	0

Table 98 • WIS_STAT3: WIS Status 3 (2×0021) (continued)

Bit	Name	Access	Description	Default
2	PLMP	RO/LH	Path label mismatch 0: Path label mismatch flag lowered 1: Path label mismatch flag raised	0
1	AISP	RO/LH	Path alarm indication signal 0: Path alarm indication signal lowered 1: Path alarm indication signal raised	0
0	LOPP	RO/LH	Loss of pointer 0: Loss of pointer flag lowered 1: Loss of pointer flag raised	0

Table 99 • WIS_REI_CNT: WIS Far-End Path Block Error Count (2×0025)

Bit	Name	Access	Description	Default
15:0	REIP_CNT	RO	Far-end path block error count. Counter wraps around to 0 when it is incremented beyond its maximum error count of 65,535.	0

Table 100 • WIS_TXJ1: WIS Tx J1s (2×0027–002E)

Bit	Name	Access	Description	Default
15:8	TX_J1_ODD	RW	Contains one octet of the transmitted path trace message. The transmitted path trace octet 1 is in address 2×0027. Octet 3 is in address 2×0028. Octet 15 is in address 2×002E.	00 (registers 2×0027–2×002D) 0×89 (register 2×002E)
7:0	TX_J1_EVEN	RW	Contains one octet of the transmitted path trace message. The transmitted path trace octet 0 is in address 2×0027. Octet 2 is in address 2×0028. Octet 14 is in address 2×002E.	0

Table 101 • WIS_RXJ1: WIS Rx J1s (2×002F–0036)

Bit	Name	Access	Description	Default
15:8	RX_J1_ODD	RO	Contains one octet of the received path trace message. The received path trace octet 1 is in address 2×002F. Octet 3 is in address 2×0030. Octet 15 is in address 2×0036.	0
7:0	RX_J1_EVEN	RO	Contains one octet of the received path trace message. The received path trace octet 0 is in address 2×002F. Octet 2 is in address 2×0030. Octet 14 is in address 2×0036.	0

Table 102 • WIS_REIL_CNT1: WIS Far-End Line BIP Errors 1 (2×0037)

Bit	Name	Access	Description	Default
15:0	REIL_ERR_CNT_MS W	RO	Most significant word of the WIS far-end line BIP error counter.	0

Table 103 • WIS_REIL_CNT0: WIS Far-End Line BIP Errors 0 (2×0038)

Bit	Name	Access	Description	Default
15:0	REIL_ERR_CNT_LS W	RO	Least significant word of the WIS far-end line BIP error counter.	0

Table 104 • WIS_B2_CNT1: WIS L-BIP Error Count 1 (2×0039)

Bit	Name	Access	Description	Default
15:0	B2_CNT_MS	RO	Most significant word of the WIS line BIP error counter.	0

Table 105 • WIS_B2_CNT0: WIS L-BIP Error Count 0 (2×003A)

Bit	Name	Access	Description	Default
15:0	B2_CNT_LSW	RO	Least significant word of the WIS line BIP error counter.	0

Table 106 • WIS_B3_CNT: WIS P-BIP Block Error Count (2×003B)

Bit	Name	Access	Description	Default
15:0	B3_CNT	RO	Path block error counter. Counter wraps around to 0 when it is incremented beyond its maximum error count of 65,535. Cleared on WIS reset.	0

Table 107 • WIS_B1_CNT: WIS S-BIP Error Count (2×003C)

Bit	Name	Access	Description	Default
15:0	B1_CNT	RO	Section BIP error counter. Counter wraps around to 0 when it is incremented beyond its maximum error count of 65,535. Cleared on WIS reset.	0

Table 108 • WIS_TXJ0: WIS Transmit J0s (2×0040–0047)

Bit	Name	Access	Description	Default
15:8	TX_J0_ODD	RW	Contains one octet of the transmitted section trace message. The transmitted section trace octet 1 is in address 2×0040. Octet 3 is in address 2×0041. Octet 15 is in address 2×0047.	00 (registers 2×0040–2×0046) 0×89 (register 2×0047)
7:0	TX_J0_EVEN	RW	Contains one octet of the transmitted section trace message. The transmitted section trace octet 0 is in address 2×0040. Octet 2 is in address 2×0041. Octet 14 is in address 2×0047.	0

Table 109 • WIS_RXJ0: WIS Rx J0s (2×0048–004F)

Bit	Name	Access	Description	Default
15:8	RX_J0_ODD	RO	Contains one octet of the received section trace message. The received section trace octet 1 is in address 2×0048. Octet 3 is in address 2×0049. Octet 15 is in address 2×004F.	0
7:0	RX_J0_EVEN	RO	Contains one octet of the received section trace message. The received section trace octet 0 is in address 2×0048. Octet 2 is in address 2×0049. Octet 14 is in address 2×004F.	0

Table 110 • EWIS_TXCTRL1: WIS Vendor-Specific Tx Control 1 (2×E600)

Bit	Name	Access	Description	Default
15	REIL_TXBLK_MODE	RW	Selects either using B2 block error count or bit error count mode to generate the M0/M1 bytes for REI-L back reporting. 0: Bit error mode 1: Block error mode	0
14	REIP_TXBLK_MODE	RW	Selects either using B3 block error count or bit error count mode to generate the G1 byte for REI-L back reporting. 0: Bit error mode 1: Block error mode	0
13	Reserved	RW	Factory test only; do not modify.	0
12	SCR	RW	Enables transmit WIS scrambler 0: Disable 1: Enable	1

Table 110 • EWIS_TXCTRL1: WIS Vendor-Specific Tx Control 1 (2×E600) (continued)

Bit	Name	Access	Description	Default
11	FRC_TX_TIMP	RW	Force transmission of a TIM-P condition within the G1 byte 0: Normal operation. 1: Force TIM-P	0
10	ERDI_TX_MODE	RW	Selects ERDI as the transmit WIS G1 byte mode 0: RDI mode 1: ERDI mode	1
9	SDH_TX_MODE	RW	Selects the format of the WIS frame structure 0: SONET mode 1: SDH mode	1
8	Reserved	RW	Factory test only; do not modify	0
7:4	SQ_WV_PW	RW	Selects the transmit WIS square wave test pattern length 0000 - 0011: Invalid 0100: 4 zeros and 4 ones 0101: 5 zeros and 5 ones 0110: 6 zeros and 6 ones 0111: 7 zeros and 7 ones 1000: 8 zeros and 8 ones 1001: 9 zeros and 9 ones 1010: 10 zeros and 10 ones 1011: 11 zeros and 11 ones 1100 - 1111: Invalid	0100
3	Reserved	RW	Factory test only; do not modify	0
2	FRC_TX_RDI	RW	Force transmission of RDI-L in the K2 byte 0: Normal operation 1: Force RDI-L	0
1	FRC_TX_AISL	RW	Force transmission of AIS-L in the K2 byte. AIS-L takes precedence over RDI-L if both are asserted. 0: Normal operation. 1: Force AIS-L	0
0	LPBK_H	RW	Enables WIS network loopback (loopback H) 0: Disable 1: Enable	0

Table 111 • Factory Test Register (2×E601)

Bit	Name	Access	Description	Default
15:2	Reserved	RO	Factory test only; do not modify	0
1	Reserved	RW	Factory test only; do not modify	0
0	Reserved	RWSC	Factory test only; do not modify	0

Table 112 • Factory Test Register (2×E602)

Bit	Name	Access	Description	Default
15:8	Reserved	RO	Factory test only; do not modify	0
7:0	Reserved	RW	Factory test only; do not modify	0

Table 113 • Factory Test Register (2×E603)

Bit	Name	Access	Description	Default
15:0	Reserved	RW	Factory test only; do not modify	0

Table 114 • Factory Test Register (2×E604)

Bit	Name	Access	Description	Default
15:0	Reserved	RW	Factory test only; do not modify	0

Table 115 • Factory Test Register (2×E605)

Bit	Name	Access	Description	Default
15:0	Reserved	RW	Factory test only; do not modify	0

Table 116 • EWIS_TX_A1_A2: E-WIS Tx A1/A2 Octets (2×E611)

Bit	Name	Access	Description	Default
15:8	TX_A1	RW	A1 byte to be transmitted when the TOSI data is inactive.	0×F6
7:0	TX_A2	RW	A2 byte to be transmitted when the TOSI data is inactive.	0×28

Table 117 • EWIS_TX_Z0_E1: E-WIS Tx Z0/E1 Octets (2×E612)

Bit	Name	Access	Description	Default
15:8	TX_Z0	RW	Z0 byte to be transmitted when the TOSI data is inactive	0×CC
7:0	TX_E1	RW	E1 byte to be transmitted when the TOSI data is inactive	0

Table 118 • EWIS_TX_F1_D1: E-WIS Tx F1/D1 Octets (2×E613)

Bit	Name	Access	Description	Default
15:8	TX_F1	RW	F1 byte to be transmitted when the TOSI data is inactive	0
7:0	TX_D1	RW	D1 byte to be transmitted when the TOSI data is inactive	0

Table 119 • EWIS_TX_D2_D3: E-WIS Tx D2/D3 Octets (2×E614)

Bit	Name	Access	Description	Default
15:8	TX_D2	RW	D2 byte to be transmitted when the TOSI data is inactive	0
7:0	TX_D3	RW	D3 byte to be transmitted when the TOSI data is inactive	0

Table 120 • EWIS_TX_C2_H1: E-WIS Tx C2/H1 Octets (2×E615)

Bit	Name	Access	Description	Default
15:8	TX_C2	RW	C2 byte to be transmitted	0×1A
7:0	TX_H1	RW	H1 byte to be transmitted	0×62

Table 121 • EWIS_TX_H2_H3: E-WIS Tx H2/H3 Octets (2×E616)

Bit	Name	Access	Description	Default
15:8	TX_H2	RW	H2 byte to be transmitted when the TOSI data is inactive	0×0A
7:0	TX_H3	RW	H3 byte to be transmitted when the TOSI data is inactive	0

Table 122 • EWIS_TX_G1_K1: E-WIS Tx G1/K1 Octets (2×E617)

Bit	Name	Access	Description	Default
15:8	Reserved	RW	Factory test only; do not modify	0
7:0	TX_K1	RW	K1 byte to be transmitted when the TOSI data is inactive	0

Table 123 • EWIS_TX_K2_F2: E-WIS Tx K2/F2 Octets (2×E618)

Bit	Name	Access	Description	Default
15:8	TX_K2	RW	K2 byte to be transmitted	0

Table 123 • EWIS_TX_K2_F2: E-WIS Tx K2/F2 Octets (2×E618) (continued)

Bit	Name	Access	Description	Default
7:0	TX_F2	RW	F2 byte to be transmitted	0

Table 124 • EWIS_TX_D4_D5: E-WIS Tx D4/D5 Octets (2×E619)

Bit	Name	Access	Description	Default
15:8	TX_D4	RW	D4 byte to be transmitted when the TOSI data is inactive	0
7:0	TX_D5	RW	D5 byte to be transmitted when the TOSI data is inactive	0

Table 125 • EWIS_TX_D6_H4: E-WIS Tx D6/H4 Octets (2×E61A)

Bit	Name	Access	Description	Default
15:8	TX_D6	RW	D6 byte to be transmitted	0
7:0	TX_H4	RW	H4 byte to be transmitted	0

Table 126 • EWIS_TX_D7_D8: E-WIS Tx D7/D8 Octets (2×E61B)

Bit	Name	Access	Description	Default
15:8	TX_D7	RW	D7 byte to be transmitted when the TOSI data is inactive	0
7:0	TX_D8	RW	D8 byte to be transmitted when the TOSI data is inactive	0

Table 127 • EWIS_TX_D9_Z3: E-WIS Tx D9/Z3 Octets (2×E61C)

Bit	Name	Access	Description	Default
15:8	TX_D9	RW	D9 byte to be transmitted	0
7:0	TX_Z3	RW	Z3 byte to be transmitted	0

Table 128 • EWIS_TX_D10_D11: E-WIS Tx D10/D11 Octets (2×E61D)

Bit	Name	Access	Description	Default
15:8	TX_D10	RW	D10 byte to be transmitted when the TOSI data is inactive	0
7:0	TX_D11	RW	D11 byte to be transmitted when the TOSI data is inactive	0

Table 129 • EWIS_TX_D12_Z4: E-WIS Tx D12/Z4 Octets (2×E61E)

Bit	Name	Access	Description	Default
15:8	TX_D12	RW	D12 byte to be transmitted	0
7:0	TX_Z4	RW	Z4 byte to be transmitted	0

Table 130 • EWIS_TX_S1_Z1: E-WIS Tx S1/Z1 Octets (2×E61F)

Bit	Name	Access	Description	Default
15:8	TX_S1	RW	S1 byte to be transmitted when the TOSI data is inactive	0×0F
7:0	TX_Z1	RW	Z1 byte to be transmitted when the TOSI data is inactive	0

Table 131 • EWIS_TX_Z2_E2: E-WIS Tx Z2/E2 Octets (2×E620)

Bit	Name	Access	Description	Default
15:8	TX_Z2	RW	Z2 byte to be transmitted when the TOSI data is inactive	0
7:0	TX_E2	RW	E2 byte to be transmitted when the TOSI data is inactive	0

Table 132 • EWIS_TX_N1: E-WIS Tx N1 Octet (2×E621)

Bit	Name	Access	Description	Default
15:8	TX_N1	RW	N1 byte to be transmitted	0
7:0	Reserved	RO	Reserved	0

Table 133 • Factory Test Register (2×E622)

Bit	Name	Access	Description	Default
15:0	Reserved	RO	Factory test only; do not modify	0

Table 134 • EWIS_TX_MSGLEN: E-WIS Tx Trace Message Length Control (2×E700)

Bit	Name	Access	Description	Default
15:4	Reserved	RO	Reserved	0

Table 134 • EWIS_TX_MSGLEN: E-WIS Tx Trace Message Length Control (2×E700) (continued)

Bit	Name	Access	Description	Default
3:2	J0_TXLEN	RW	Selects length of transmitted section trace message 00: 16-byte trace length 01: 64-byte trace length 10: 1-byte trace length 11: 1-byte trace length	0
1:0	J1_TXLEN	RW	Selects length of transmitted path trace message 00: 16-byte trace length 01: 64-byte trace length 10: 1-byte trace length 11: 1-byte trace length	0

Table 135 • EWIS_TXJ0: E-WIS Tx J0s 16–63 (2×E800-E817)

Bit	Name	Access	Description	Default
15:8	J0_TX64_ODD	RW	Contains one octet of the transmitted section trace message. Octet 17 is in 2×E800, octet 19 is in 2×E801, and so on.	0
7:0	J0_TX64_EVEN	RW	Contains one octet of the transmitted section trace message. Octet 16 is in 2×E800, octet 18 is in 2×E801, and so on.	0

Table 136 • EWIS_RXJ0: E-WIS Rx J0s 16–63 (2×E900-E917)

Bit	Name	Access	Description	Default
15:8	J0_RX64_ODD	RO	Contains one octet of the received section trace message. Octet 17 is in 2×E900, octet 19 is in 2×E901, and so on.	0
7:0	J0_RX64_EVEN	RO	Contains one octet of the received section trace message. Octet 16 is in 2×E900, octet 18 is in 2×E901, and so on.	0

Table 137 • EWIS_TXJ1: E-WIS Tx WIS J1s 16–63 (2×EA00-EA17)

Bit	Name	Access	Description	Default
15:8	J1_TX64_ODD	RW	Contains one octet of the transmitted path trace message. Octet 17 is in 2×EA00, octet 19 is in 2×EA01, and so on.	0
7:0	J1_TX64_EVEN	RW	Contains one octet of the transmitted path trace message. Octet 16 is in 2×EA00, octet 18 is in 2×EA01, and so on.	0

Table 138 • EWIS_RXJ1: E-WIS Rx J1s 16–63 (2×EB00-EB17)

Bit	Name	Access	Description	Default
15:8	J1_RX64_ODD	RO	Contains one octet of the received path trace message. Octet 17 is in 2×EB00, octet 19 is in 2×EB01, and so on.	0
7:0	J1_RX64_EVEN	RO	Contains one octet of the received path trace message. Octet 16 is in 2×EB00, octet 18 is in 2×EB01, and so on.	0

Table 139 • EWIS_RX_FRM_CTRL1: E-WIS Rx Framer Control 1 (2×EC00)

Bit	Name	Access	Description	Default
15	Reserved	RO	Reserved	0
14:10	HUNT_A1	RW	The number of consecutive A1 octets that the receive framer must find before it can exit the HUNT state 0: Undefined 1–16: 1–16 17–31: Undefined	00100
9:5	PRESYNC_A1	RW	The number of consecutive A1 octets in the presync pattern preceding the first A2 octet 0: 1 1–16: 1–16 17–31: 16	10000
4:0	PRESYNC_A2	RW	The number of consecutive A2 octets in the presync pattern following the last A1 octet 0: Only the four MSB of the first A2 byte are compared 1–16: 1–16 17–31: 16	10000

Table 140 • EWIS_RX_FRM_CTRL2: E-WIS Rx Framer Control 2 (2×EC01)

Bit	Name	Access	Description	Default
15:13	Reserved	RO	Reserved.	0
12:8	SYNC_PAT	RW	Synchronization pattern to be used after the presync pattern has been detected. 0: Sync pattern is A1 plus the four most significant bits of A2. 1: Sync pattern is two A1s plus one A2 (A1A1A2). 2–16: Sync pattern is the number of consecutive A1s followed by the same number of A2s. For example, the sync pattern is A1A1A2A2 when 2 is the setting. 17–31: Undefined.	00010

Table 140 • EWIS_RX_FRM_CTRL2: E-WIS Rx Framer Control 2 (2×EC01) (continued)

Bit	Name	Access	Description	Default
7:4	SYNC_ENTRY_CNT	RW	Number of consecutive frame boundaries to be detected after finding the presync pattern before the framer can enter the SYNC state. 0: 1. 1–15: 1–15.	0100
3:0	SYNC_EXIT_CNT	RW	Number of consecutive frame boundary location errors tolerated/detected before exiting the SYNC state. 0: 1. 1–15: 1–15.	0100

Table 141 • EWIS_LOF_CTRL1: E-WIS Loss of Frame Control 1 (2×EC02)

Bit	Name	Access	Description	Default
15:12	Reserved	RO	Reserved	0
11:6	LOF_T1	RW	Defines the number of frames periods (nominally 125 microseconds) during which OOF must persist to trigger LOF. This is not a count of continuous frames. An integrating counter is used. 0×0: Undefined. 0×1: 1 frame time (125 μs). 0×2: 2 frame times (250 μs). --- 0×18: 24 frame times (3 ms). 0×3F: 63 frame times (7.875 ms).	0×18
5:0	LOF_T2	RW	Defines the number of consecutive frame periods (nominally 125 μs) during which OOF status must not be true in order to clear loss of frame set count (the counter associated with 2×EC02.11:6). 0×0: Undefined. 0×1: 1 frame time (125 μs). 0×2: 2 frame times (250 μs). --- 0×18: 24 frame times (3 ms). 0×3F: 63 frame times (7.875 ms).	0×18

Table 142 • EWIS_LOF_CTRL2: E-WIS Loss of Frame Control 2 (2×EC03)

Bit	Name	Access	Description	Default
15:7	Reserved	RO	Reserved	0

Table 142 • EWIS_LOF_CTRL2: E-WIS Loss of Frame Control 2 (2×EC03) (continued)

Bit	Name	Access	Description	Default
6:1	LOF_T3	RW	Defines number of consecutive frames (normally 125 μ s) for which the receive framer must be in its sync state in order to clear the LOF status 0×0: Undefined 0×1: 1 frame time (125 μ s) 0×2: 2 frame times (250 μ s) --- 0×18: 24 frame times (3 ms) 0×3F: 63 frame times (7.875 ms)	0×18
0	Reserved	RW	Factory test only; do not modify	0

Table 143 • EWIS_RX_CTRL1: E-WIS Rx Control 1 (2×EC10)

Bit	Name	Access	Description	Default
15:2	Reserved	RO	Reserved	0
1	DSCR_ENA	RW	Enables the WIS descrambler 0: Disable 1: Enable	1
0	B3_CALC_MOD E	RW	Selects whether or not the fixed stuff bytes are included in the receive Path BIP error calculation 0: The fixed stuff bytes are excluded from the B3 calculation 1: The fixed stuff bytes are included in the B3 calculation	1

Table 144 • EWIS_RX_MSGLEN: E-WIS Rx Trace Message Length Control (2×EC20)

Bit	Name	Access	Description	Default
15:4	Reserved	RO	Reserved	0
3:2	J0_RX_LEN	RW	Selects the expected length of the received Section trace message 00: 16-byte trace length 01: 64-byte trace length 10: 1-byte trace length 11: 1-byte trace length	0
1:0	J1_RX_LEN	RW	Selects the length of the expected Path trace message 00: 16-byte trace length 01: 64-byte trace length 10: 1-byte trace length 11: 1-byte trace length	0

Table 145 • EWIS_RX_ERR_FRC1: E-WIS Rx Error Force Control 1 (2×EC30)

Bit	Name	Access	Description	Default
15:13	Reserved	RO	Reserved	0
12	FRC_LOPC	RW	Force a loss of optical carrier (LOPC) condition 0: Normal operation 1: Force LOPC	0
11	FRC_LOS	RW	Force a loss of signal (LOS) condition in the WIS receive data path 0: Normal operation 1: Forced receive LOS	0
10	FRC_OOF	RW	Force the receive framer into the out-of-frame (OOF) state 0: Normal operation 1: Force receive OOF	0
9	LOPC_POL_SEL	RW	Selects the polarity of the LOPC input pin 0: LOPC asserted when input is low 1: LOPC asserted when input is high	0
8	RXLOF_ON_LOPC	RW	Selects whether or not the LOPC input has any effect on alarm conditions detected by the device 0: LOPC condition does not effect the state of the LOF or SEF status, nor the state of the receive path framer 1: LOF and SEF are asserted and the receive path framer is put into its out-of-frame state during an LOPC condition	0
7:4	APS_THRES	RW	Defines the number of consecutive frames received before asserting the AIS-L and RDI-L alarms 3–15: Threshold value All others: Reserved	0101
3	FRC_RX_AISL	RW	Force a line alarm indication signal (AIS-L) condition in the WIS receive data path 0: Normal operation 1: Device forced into Rx AIS-L condition	0
2	FRC_RX_RDIL	RW	Force a line remote defect identifier (RDI-L) condition in the WIS receive data path 0: Normal operation 1: Device forced into Rx RDI-L condition	0
1	FRC_RX_AISP	RW	Force a path alarm indication signal (AIS-P) condition in the WIS receive data path 0: Normal operation 1: Device forced into Rx AIS-P condition	0
0	FRC_RX_LOP	RW	Force a loss of pointer (LOP) condition to the starting location of the frame's SPE (synchronous payload envelope) in the WIS receive data path 0: Normal operation 1: Device forced into Rx LOP condition	0

Table 146 • EWIS_RX_ERR_FRC2: E-WIS Rx Error Force Control 2 (2×EC31)

Bit	Name	Access	Description	Default
15	FRC_RX_UNEQP	RW	Force a unequipped path (UNEQ-P) defect in the WIS receive data path. 0: Normal operation. 1: Device forced into Rx UNEQ-P condition.	0
14	FRC_RX_PLMP	RW	Force a payload label mismatch (PLM-P) defect in the WIS receive data path. 0: Normal operation. 1: Device forced into Rx PLM-P condition.	0
13	FRC_RX_RDIP	RW	Force a far-end path remote defect identifier condition in the WIS receive data path. 0: Normal operation. 1: Device forced into Rx far-end RDI-P condition.	0
12	FRC_RX_FE_AISP	RW	Force a far-end path alarm indication signal condition in the WIS receive data path. 0: Normal operation. 1: Device forced into Rx far-end AIS-P condition.	0
11	FRC_RX_FE_UNEQP	RW	Force a far-end unequipped path defect in the WIS receive data path. 0: Normal operation. 1: Device forced into Rx far-end UNEQ-P condition.	0
10	FRC_RX_FE_PLMP	RW	Force a far-end payload label mismatch defect in the WIS receive data path. 0: Normal operation. 1: Device forced into Rx far-end PLM-P condition.	0
9	FRC_RX_REIP	RW	Force a path remote error indication (REI-P) condition in the WIS receive data path. The error is reflected in register 2×EF04.3. 0: Normal operation. 1: Device forced into Rx REI-P condition.	0
8	FRC_RX_REIL	RW	Force a line remote error indication (REI-L) condition in the WIS receive data path. The error is reflected in register 2×EF04.4. 0: Normal operation. 1: Device forced into Rx REI-L condition.	0
7	FRC_RX_SEF	RW	Force a severely errored frame (SEF) condition in the WIS receive data path. 0: Normal operation. 1: Device forced into Rx SEF condition.	0
6	FRC_RX_LOF	RW	Force a loss of frame (LOF) condition in the WIS receive data path. 0: Normal operation. 1: Device forced into Rx LOF condition.	0

Table 146 • EWIS_RX_ERR_FRC2: E-WIS Rx Error Force Control 2 (2×EC31) (continued)

Bit	Name	Access	Description	Default
5	FRC_RX_B1	RW	Force a PMTICK B1 BIP error condition (B1NZ) in the WIS receive data path. 0: Normal operation. 1: Device forced into PMTICK B1 BIP error condition.	0
4	FRC_RX_B2	RW	Force a PMTICK B2 BIP error condition (B2NZ) in the WIS receive data path. 0: Normal operation. 1: Device forced into PMTICK B2 BIP error condition.	0
3	FRC_RX_B3	RW	Force a PMTICK B3 BIP error condition (B3NZ) in the WIS receive data path. 0: Normal operation. 1: Device forced into PMTICK B3 BIP error condition.	0
2	FRC_RX_LCDP	RW	Force a loss of code-group delineation (LCD-P) defect in the WIS receive data path. 0: Normal operation. 1: Device forced into Rx LCD-P condition.	0
1	FRC_RX_REIL_NZ	RW	Force a far-end line BIP error condition (far-end B2NZ) in the WIS receive data path. The error is reflected in register 2×EF04.2. 0: Normal operation. 1: Device forced into Rx far-end line BIP error condition.	0
0	FRC_RX_REIP_NZ	RW	Force a far-end path BIP error condition (far-end B3NZ) in the WIS receive data path. The error is reflected in register 2×EF04.1. 0: Normal operation. 1: Device forced into Rx far-end path BIP error condition.	0

Table 147 • EWIS_MODE_CTRL: E-WIS Mode Control (2×EC40)

Bit	Name	Access	Description	Default
15:13	Reserved	RO	Reserved.	0
12	REI_MODE	RW	Selects REI extraction from the M0/M1 bytes in the WIS receive data path. 0: SONET mode enabled. Uses M1 only. 1: SDH mode enabled. Uses M0 and M1.	0
11	SDH_RX_MODE	RW	Selects H1/H2 pointer processing. 0: SONET mode. 1: SDH mode.	0
10:9	Reserved	RW	Factory test only; do not modify.	0

Table 147 • EWIS_MODE_CTRL: E-WIS Mode Control (2×EC40) (continued)

Bit	Name	Access	Description	Default
8	RX_ERDI_MOD E	RW	Selects ERDI-P/RDI-P extraction from the G1 byte in the WIS received data. 0: RDI-P is reported in bit 5, bits 6 and 7 are unused. 1: ERDI is reported in bits 5–7. 101 indicates far-end AIS-P. 110 indicates far-end UNEQ-P. 010 indicates far-end PLM-P.	1
7:0	C2_EXP	RW	Expected C2 receive octet. A PLM-P alarm is generated if this octet value is not received.	0×1A

Table 148 • Factory Test Register (2×EC41)

Bit	Name	Access	Description	Default
15:0	Reserved	RO	Factory test only; do not modify.	0

Table 149 • EWIS_PRBS31_ANA_CTRL: E-WIS PRBS31 Analyzer Control (2×EC50)

Bit	Name	Access	Description	Default
15:2	Reserved	RO	Reserved.	0
1	PRBS31_FRC_ER R	RW	Inject a single bit error into the WIS PRBS31 pattern checker. A single bit error results in the error counter incrementing by 3 (one error for each tap of the checker). 0: Normal operation. 1: Inject error.	0
0	PRBS31_FRC_SAT	RWSC	Force the PRBS31 pattern error counter to a value of 65528. This can be useful for testing the saturating feature of the counter. 0: Normal operation. 1: Force the PRBS31 error counter to a value of 65528. Forcing the counter to 65528 through this bit has no effect on register 2×EC51.1.	0

Table 150 • EWIS_PRBS31_ANA_STAT: E-WIS PRBS31 Analyzer Status (2×EC51)

Bit	Name	Access	Description	Default
15:2	Reserved	RO	Reserved.	0

Table 150 • EWIS_PRBS31_ANA_STAT: E-WIS PRBS31 Analyzer Status (2×EC51) (continued)

Bit	Name	Access	Description	Default
1	PRBS31_ERR	RO	Status bit indicating if the WIS PRBS31 error counter is non-zero. 0: Counter is zero. 1: Counter is non-zero. When the WIS PRBS31 analyzer is disabled, this bit might still be on. When the analyzer is re-enabled, this bit is cleared. If needed, the device reset can be used to clear the status.	0
0	PRBS31_ANA_STAT E	RO	Indicates when the Rx WIS PRBS31 pattern checker is synchronized to the incoming data. 0: PRBS31 pattern checker is not synchronized to the data. PRBS31 error counter value is not valid. 1: PRBS31 pattern checker is synchronized to the data.	0

Table 151 • EWIS_PMTICK_CTRL: E-WIS Performance Monitor Control (2×EC60)

Bit	Name	Access	Description	Default
15:3	PMTICK_DU R	RW	Sets the interval for updating the PMTICK error counters when the PMTICK_SRC bit is 1. The value represents the number of 125 μs increments between PMTICK events. 0: Undefined. 1: Undefined. 2: 250 μs. - - - 8: 1 ms. 8000: 1 second 8191: 1.024 seconds	0×1F40
2	PMTICK_ENA	RW	Enables the PMTICK counters to be updated on a PMTICK event. The source of the PMTICK event is determined by the PMTICK_SRC bit. 0: Disable. 1: Enable.	0
1	PMTICK_SRC	RW	Selects how the PMTICK counters are updated. The PMTICK counters are updated with the selected source only if the PMTICK enable bit is set. 0: PMTICK counters updated on a rising edge of the PMTICK pin. 1: PMTICK counters updated when the PMTICK counter reaches its terminal count.	1
0	PMTICK_FRC	RWSC	Force the PMTICK counters to update, regardless of the PMTICK_ENA or PMTICK_SRC settings. 0: Normal operation. 1: Forces PMTICK event.	0

Table 152 • EWIS_CNT_CFG: E-WIS Counter Configuration (2×EC61)

Bit	Name	Access	Description	Default
15:12	Reserved	RO	Reserved	0
11	B1_BLK_MODE	RW	Enables block mode (increment once for each errored frame) counting for the B1 BIP PMTICK counter. 0: Bit mode 1: Block mode	0
10	B2_BLK_MODE	RW	Enables block mode (increment once for each errored frame) counting for the B2 BIP PMTICK counter 0: Bit mode 1: Block mode	0
9	B3_BLK_MODE	RW	Enables block mode (increment once for each errored frame) counting for the B3 BIP PMTICK counter 0: Bit mode 1: Block mode	0
8:6	Reserved	RO	Reserved	0
5	REIP_BLK_MODE	RW	Enables block mode (increment once for each errored frame) counting for the REI-P (far-end B3 error count in the G1 byte) PMTICK counter 0: Bit mode 1: Block mode	0
4	REIL_BLK_MODE	RW	Enables block mode (increment once for each errored frame) counting for the REI-L (far-end B2 error count in the M0/M1 byte) PMTICK counter 0: Bit mode 1: Block mode	0
3:0	Reserved	RO	Reserved	0

Table 153 • EWIS_CNT_STAT: E-WIS Counter Status (2×EC62)

Bit	Name	Access	Description	Default
15:3	Reserved	RO	Reserved	0
2	REIP_CNT_STAT	RO	Status bit indicating if the REI-P (far-end B3) PMTICK counter is non-zero 0: Counter is zero 1: Counter is non-zero Counter is not impacted by FRC_RX_REIP or FRC_RX_REIP_NZ.	0
1	REIL_CNT_STAT	RO	Status bit indicating if the REI-L (far-end B2) PMTICK counter is non-zero 0: Counter is zero 1: Counter is non-zero Counter is not impacted by FRC_RX_REIL or FRC_RX_REIL_NZ.	0

Table 153 • EWIS_CNT_STAT: E-WIS Counter Status (2×EC62) (continued)

Bit	Name	Access	Description	Default
0	Reserved	RO	Factory test only; do not modify	0

Table 154 • EWIS_REIP_CNT1: E-WIS P-REI Counter 1 (MSW) (2×EC80)

Bit	Name	Access	Description	Default
15:0	REIP_ERR_CNT_MS W	RO	PMTICK statistical error count of the far-end B3 errors (reported in the G1 byte). 16 MSB are in this register, 16 LSB are in the next register. The count is updated only on a PMTICK event. The counter saturates to all ones.	0

Table 155 • EWIS_REIP_CNT0: E-WIS P-REI Counter 0 (LSW) (2×EC81)

Bit	Name	Access	Description	Default
15:0	REIP_ERR_CNT_LS W	RO	PMTICK statistical error count of the far-end B3 errors (reported in the G1 byte). 16 LSB are in this register, 16 MSB are in the previous register. The count is updated only on a PMTICK event. The counter saturates to all ones.	0

Table 156 • EWIS_REIL_CNT1: E-WIS L-REI Counter 1 (MSW) (2×EC90)

Bit	Name	Access	Description	Default
15:0	REIL_ERR_CNT_MS W	RO	PMTICK statistical error count of the far-end B2 errors (reported in the M0/M1 bytes). 16 MSB are in this register, 16 LSB are in the next register. The count is updated only on a PMTICK event. The counter saturates to all ones.	0

Table 157 • EWIS_REIL_CNT0: E-WIS L-REI Counter 0 (LSW) (2×EC91)

Bit	Name	Access	Description	Default
15:0	REIL_ERR_CNT_LS W	RO	PMTICK statistical error count of the far-end B2 errors (reported in the M0/M1 bytes). 16 LSB are in this register, 16 MSB are in the previous register. The count is updated only on a PMTICK event. The counter saturates to all ones.	0

Table 158 • Factory Test Register (2×ECA0)

Bit	Name	Access	Description	Default
15:0	Reserved	RO	Factory test only; do not modify	0

Table 159 • EWIS_B1_ERR_CNT1: E-WIS S-BIP Error Counter 1 (MSW) (2×ECB0)

Bit	Name	Access	Description	Default
15:0	B1_ERR_CNT_MS W	RO	PMTICK statistical error count of the B1 BIP errors. 16 MSB are in this register, 16 LSB are in the next register. The count is updated only on a PMTICK event. The counter saturates to all ones.	0

Table 160 • EWIS_B1_ERR_CNT0: E-WIS S-BIP Error Counter 0 (LSW) (2×ECB1)

Bit	Name	Access	Description	Default
15:0	B1_ERR_CNT_LS W	RO	PMTICK statistical error count of the B1 BIP errors. 16 LSB are in this register, 16 MSB are in the previous register. The count is updated only on a PMTICK event. The counter saturates to all ones.	0

Table 161 • EWIS_B2_ERR_CNT1: E-WIS L-BIP Error Counter 1 (MSW) (2×ECB2)

Bit	Name	Access	Description	Default
15:0	B2_ERR_CNT_MS W	RO	PMTICK statistical error count of the B2 BIP errors. 16 MSB are in this register, 16 LSB are in the next register. The count is updated only on a PMTICK event. The counter saturates to all ones.	0

Table 162 • EWIS_B2_ERR_CNT0: E-WIS L-BIP Error Counter 0 (LSW) (2×ECB3)

Bit	Name	Access	Description	Default
15:0	B2_ERR_CNT_LSW	RO	PMTICK statistical error count of the B2 BIP errors. 16 LSB are in this register, 16 MSB are in the previous register. The count is updated only on a PMTICK event. The counter saturates to all ones.	0

Table 163 • EWIS_B3_ERR_CNT1: E-WIS P-BIP Error Counter 1 (MSW) (2×ECB4)

Bit	Name	Access	Description	Default
15:0	B3_ERR_CNT_MSW	RO	PMTICK statistical error count of the B3 BIP errors. 16 MSB are in this register, 16 LSB are in the next register. The count is updated only on a PMTICK event. The counter saturates to all ones.	0

Table 164 • EWIS_B3_ERR_CNT0: E-WIS P-BIP Error Counter 0 (LSW) (2×ECB5)

Bit	Name	Access	Description	Default
15:0	B3_ERR_CNT_LS W	RO	PMTICK statistical error count of the B3 BIP errors. 16 LSB are in this register, 16 MSB are in the previous register. The count is updated only on a PMTICK event. The counter saturates to all ones.	0

Table 165 • Factory Test Register (2×ED00–ED08)

Bit	Name	Access	Description	Default
15:0	Reserved	RO	Factory test only; do not modify	0

Table 166 • EWIS_RXTX_CTRL: E-WIS Rx to Tx Control (2×EE00)

Bit	Name	Access	Description	Default
15:7	Reserved	RO	Reserved.	0
6	RXAISL_ON_LOP C	RW	Selects if an LOPC condition contributes to the Rx AIS-L alarm. 0: LOPC condition does not cause the AIS-L alarm to be set. 1: LOPC condition causes the AIS-L alarm to be set.	0
5	RXAISL_ON_LOS	RW	Selects if an LOS condition contributes to the Rx AIS-L alarm. 0: LOS condition does not cause the AIS-L alarm to be set. 1: LOS condition causes the AIS-L alarm to be set.	0
4	RXAISL_ON_LOF	RW	Selects if an LOF condition contributes to the Rx AIS-L alarm. 0: LOF condition does not cause the AIS-L alarm to be set. 1: LOF condition causes the AIS-L alarm to be set.	0

Table 166 • EWIS_RXTX_CTRL: E-WIS Rx to Tx Control (2×EE00) (continued)

Bit	Name	Access	Description	Default
3	TXRDIL_ON_LOP C	RW	Selects if a RDI-L is reported in the Tx frame's K2 byte when an LOPC condition is detected. 0: RDI-L is not reported when LOPC is detected. 1: RDI-L is reported when LOPC is detected.	0
2	TXRDIL_ON_LOS	RW	Selects whether or not RDI-L is reported in the Tx frame's K2 byte when an LOS condition is detected. 0: RDI-L is not reported when LOS is detected. 1: RDI-L is reported when LOS is detected.	0
1	TXRDIL_ON_LOF	RW	Selects whether or not RDI-L is reported in the Tx frame's K2 byte when an LOF condition is detected. 0: RDI-L is not reported when LOF is detected. 1: RDI-L is reported when LOF is detected.	0
0	TXRDIL_ON_AISL	RW	Selects whether or not RDI-L is reported in the Tx frame's K2 byte when a Rx AIS-L condition is detected. 0: RDI-L is not reported when a Rx AIS-L condition is detected. 1: RDI-L is reported when a Rx AIS-L condition is detected.	0

Table 167 • EWIS_PEND1: E-WIS Interrupt Pending 1 (2×EF00)

Bit	Name	Access	Description	Default
15:14	Reserved	RO	Reserved.	0
13	MSTCODE1_PEND	ROCR	Interrupt pending. MSTCODE[1] input pin has changed state since this register was last read. The MSTCODE[1] pin status is reported in 1×E607.14. 0: MSTCODE[1] pin has not changed state since last read of this register. 1: MSTCODE[1] pin has changed state.	0
12	MSTCODE0_PEND	ROCR	Interrupt pending. MSTCODE[0] input pin has changed state since this register was last read. The MSTCODE[1] pin status is reported in 1×E607.13. 0: MSTCODE[0] pin has not changed state since last read of this register. 1: MSTCODE[0] pin has changed state.	0
11	SEF_PEND	ROCR	Interrupt pending. SEF has changed state since this register was last read. 0: SEF condition has not changed state. 1: SEF condition has changed state.	0

Table 167 • EWIS_PEND1: E-WIS Interrupt Pending 1 (2×EF00) (continued)

Bit	Name	Access	Description	Default
10	FEPLMP_LCDP_PEND	ROCR	Interrupt pending. Far-end path label mismatch (PLM-P)/loss of code-group delineation (LCD-P) condition has changed state since this register was last read. 0: PLM-P/LCD-P has not changed state. 1: PLM-P/LCD-P condition has changed state.	0
9	FEAISP_LOPP_PEND	ROCR	Interrupt pending. Far-end path alarm indication signal (AIS-P)/path loss of pointer (LOP) condition has changed state since this register was last read. 0: Far-end AIS-P/LOP-P condition has not changed state. 1: Far-end AIS-P/LOP-P condition has changed state.	0
8	Reserved	RO	Reserved	0
7	LOF_PEND	ROCR	Interrupt pending. Loss of frame (LOF) condition has changed state since this register was last read. 0: LOF condition has not changed state. 1: LOF condition has changed state.	0
6	LOS_PEND	ROCR	Interrupt pending. Loss of signal (LOS) condition has changed state since this register was last read. This bit does not assert if LOPC is active at the time LOS changes state. 0: LOS condition has not changed state. 1: LOS condition has changed state.	0
5	RDIL_PEND	ROCR	Interrupt pending. Line remote defect indication (RDI-L) has changed state since this register was last read. 0: RDI-L condition has not changed state. 1: RDI-L condition has changed state.	0
4	AISL_PEND	ROCR	Interrupt pending. Line alarm indication signal (AIS-L) has changed state since this register was last read. This bit does not assert if LOPC, LOS, LOF, or SEF are asserted at the time AIS-L changes state. 0: AIS-L condition has not changed state. 1: AIS-L condition has changed state.	0
3	LCDP_PEND	ROCR	Interrupt pending. Loss of code-group delineation (LCD-P) has changed state since this register was last read. This bit does not assert if AIS-L, AIS-P, UNEQ-P, or PLM-P are asserted at the time LCD-P changes state. 0: LCD-P condition has not changed state. 1: LCD-P condition has changed state.	0

Table 167 • EWIS_PEND1: E-WIS Interrupt Pending 1 (2×EF00) (continued)

Bit	Name	Access	Description	Default
2	PLMP_PEND	ROCR	Interrupt pending. Path label mismatch (PLM-P) has changed state since this register was last read. This bit does not assert if LOP-P or AIS-P are asserted at the time PLM-P changes state. 0: PLM-P condition has not changed state. 1: PLM-P condition has changed state.	0
1	AISP_PEND	ROCR	Interrupt pending. Path alarm indication signal (AIS-P) has changed state since this register was last read. This bit does not assert if LOPC, LOS, SEF, LOF, or AIS-L are asserted at the time AIS-P changes state. 0: AIS-P condition has not changed state. 1: AIS-P condition has changed state.	0
0	LOPP_PEND	ROCR	Interrupt pending. Path loss of pointer (LOP-P) has changed state since this register was last read. 0: LOP-P condition has not changed state. 1: LOP-P condition has changed state.	0

Table 168 • EWIS_MASKA_1: E-WIS Interrupt Mask A 1 (2×EF01)

Bit	Name	Access	Description	Default
15:14	Reserved	RO	Reserved	0
13	MSTCODE1_MASKA	RW	Enables propagation of MSTCODE1_PEND to the WIS_INTA pin 0: Disable 1: Enable	0
12	MSTCODE0_MASKA	RW	Enables propagation of MSTCODE0_PEND to the WIS_INTA pin 0: Disable 1: Enable	0
11	SEF_MASKA	RW	Enables propagation of SEF_PEND to the WIS_INTA pin 0: Disable 1: Enable	0
10	FEPLMP_LCDP_MASKA	RW	Enables propagation of FEPLMP_LCDP_PEND to the WIS_INTA pin 0: Disable 1: Enable	0
9	FEAISP_LOPP_MASKA	RW	Enables propagation of FEAISP_LOPP_PEND to the WIS_INTA pin 0: Disable 1: Enable	0
8	Reserved	RO	Reserved	0

Table 168 • EWIS_MASKA_1: E-WIS Interrupt Mask A 1 (2×EF01) (continued)

Bit	Name	Access	Description	Default
7	LOF_MASKA	RW	Enables propagation of LOF_PEND to the WIS_INTA pin 0: Disable 1: Enable	0
6	LOS_MASKA	RW	Enables propagation of LOS_PEND to the WIS_INTA pin 0: Disable 1: Enable	0
5	RDIL_MASKA	RW	Enables propagation of RDIL_PEND to the WIS_INTA pin 0: Disable 1: Enable	0
4	AISL_MASKA	RW	Enables propagation of AISL_PEND to the WIS_INTA pin 0: Disable 1: Enable	0
3	LCDP_MASKA	RW	Enables propagation of LCDP_PEND to the WIS_INTA pin 0: Disable 1: Enable	0
2	PLMP_MASKA	RW	Enables propagation of PLMP_PEND to the WIS_INTA pin 0: Disable 1: Enable	0
1	AISP_MASKA	RW	Enables propagation of AISP_PEND to the WIS_INTA pin 0: Disable 1: Enable	0
0	LOPP_MASKA	RW	Enables propagation of LOPP_PEND to the WIS_INTA pin 0: Disable 1: Enable	0

Table 169 • EWIS_MASKB_1: E-WIS Interrupt Mask B 1 (2×EF02)

Bit	Name	Access	Description	Default
15:14	Reserved	RO	Reserved	0
13	MSTCODE1_MASKB		Enables propagation of MSTCODE1_PEND to the WIS_INTB pin 0: Disable 1: Enable	
12	MSTCODE0_MASKB		Enables propagation of MSTCODE0_PEND to the WIS_INTB pin 0: Disable 1: Enable	

Table 169 • EWIS_MASKB_1: E-WIS Interrupt Mask B 1 (2×EF02) (continued)

Bit	Name	Access	Description	Default
11	SEF_MASKB	RW	Enables propagation of SEF_PEND to the WIS_INTB pin 0: Disable 1: Enable	0
10	FEPLMP_LCDP_MAS KB	RW	Enables propagation of FEPLMP_LCDP_PEND to the WIS_INTB pin 0: Disable 1: Enable	0
9	FEAISP_LOPP_MASK B	RW	Enables propagation of FEAISP_LOPP_PEND to the WIS_INTB pin 0: Disable 1: Enable	0
8	Reserved	RO	Reserved	0
7	LOF_MASKB	RW	Enables propagation of LOF_PEND to the WIS_INTB pin 0: Disable 1: Enable	0
6	LOS_MASKB	RW	Enables propagation of LOS_PEND to the WIS_INTB pin 0: Disable 1: Enable	0
5	RDIL_MASKB	RW	Enables propagation of RDIL_PEND to the WIS_INTB pin 0: Disable 1: Enable	0
4	AISL_MASKB	RW	Enables propagation of AISL_PEND to the WIS_INTB pin 0: Disable 1: Enable	0
3	LCDP_MASKB	RW	Enables propagation of LCDP_PEND to the WIS_INTB pin 0: Disable 1: Enable	0
2	PLMP_MASKB	RW	Enables propagation of PLMP_PEND to the WIS_INTB pin 0: Disable 1: Enable	0
1	AISP_MASKB	RW	Enables propagation of AISP_PEND to the WIS_INTB pin 0: Disable 1: Enable	0
0	LOPP_MASKB	RW	Enables propagation of LOPP_PEND to the WIS_INTB pin 0: Disable 1: Enable	0

Table 170 • EWIS_INTR_STAT2: E-WIS Interrupt Status 2 (2×EF03)

Bit	Name	Access	Description	Default
15:14	Reserved	RO	Reserved	0
13	TXLOL_STAT	RO	PMA CMU loss of lock status 0: No PMA CMU lock error 1: PMA CMU lock error	0
12	RXLOL_STAT	RO	PMA CRU loss of lock status 0: No PMA CRU lock error 1: PMA CRU lock error	0
11	LOPC_STAT	RO	Loss of optical carrier (LOPC) status 0: The LOPC input pin is deasserted 1: The LOPC input pin is asserted	0
10	UNEQ_P_STAT	RO	Unequipped path (UNEQ-P) status 0: UNEQ-P is deasserted 1: UNEQ-P is asserted	0
9	FEUNEQ_P_STAT	RO	Far-end unequipped path (UNEQ-P) status 0: Far-end UNEQ-P is deasserted 1: Far-end UNEQ-P is asserted	0
8	FERDIP_STAT	RO	Far-end path remote defect identifier (RDI-P) status 0: Far-end RDI-P is deasserted 1: Far-end RDI-P is asserted	0
7	B1_NZ_STAT	RO	PMTICK B1 BIP (B1_ERR_CNT) counter status 0: B1_ERR_CNT is zero 1: B1_ERR_CNT is non-zero	0
6	B2_NZ_STAT	RO	PMTICK B2 BIP (B2_ERR_CNT) counter status 0: B2_ERR_CNT is zero 1: B2_ERR_CNT is non-zero	0
5	B3_NZ_STAT	RO	PMTICK B3 BIP (B3_ERR_CNT) counter status 0: B3_ERR_CNT is zero 1: B3_ERR_CNT is non-zero	0
4	REIL_STAT	RO	Line remote error indication (REI-L) value status 0: The REI-L value in the last received frame reported no errors 1: The REI-L value in the last received frame reported errors	0
3	REIP_STAT	RO	Path remote error indication (REI-P) value status 0: The REI-P value in the last received frame reported no errors 1: The REI-P value in the last received frame reported errors Note: When an invalid REI-P value of 9 to 15 is received, the REI-P status bit will be triggered, even though the REI-P counter is not incremented.	0
2	REIL_NZ_STAT	RO	PMTICK REI-L (REIL_ERR_CNT) counter status 0: REIL_ERR_CNT is zero 1: REIL_ERR_CNT is non-zero	0

Table 170 • EWIS_INTR_STAT2: E-WIS Interrupt Status 2 (2×EF03) (continued)

Bit	Name	Access	Description	Default
1	REIP_NZ_STAT	RO	PMTICK REI-P (REIP_ERR_CNT) counter status 0: REIP_ERR_CNT is zero 1: REIP_ERR_CNT is non-zero	0
0	HIGH_BER_STA T	RO	PCS high bit error rate (BER) status 0: No high BER 1: The PCS block indicates a high bit error rate	0

Table 171 • EWIS_INTR_PEND2: E-WIS Interrupt Pending 2 (2×EF04)

Bit	Name	Access	Description	Default
15	Reserved	RO	Reserved.	0
14	PMTICK_PEND	ROCR	Interrupt pending. A PMTICK event (regardless of the source) has occurred since this register was last read. 0: A PMTICK event has not occurred. 1: A PMTICK event occurred.	0
13	TXLOL_PEND	ROCR	Interrupt pending. PMA CMU lock signal (TXLOL_STAT) has changed state since this register was last read. 0: TXLOL_STAT has not changed state. 1: TXLOL_STAT has changed state.	0
12	RXLOL_PEND	ROCR	Interrupt pending. PMA CRU lock signal (RXLOL_STAT) has changed state since this register was last read. 0: RXLOL_STAT has not changed state. 1: RXLOL_STAT has changed state.	0
11	LOPC_PEND	ROCR	Interrupt pending. Loss of optical carrier (LOPC) input pin (LOPC_STAT) has changed state since this register was last read. 0: LOPC_STAT has not changed state. 1: LOPC_STAT has changed state.	0
10	UNEQP_PEND	ROCR	Interrupt pending. Unequipped path (UNEQP_STAT) has changed state since this register was last read. This bit does not assert if LOP-P or AIS-P are asserted at the time UNEQP changes state. 0: UNEQP_STAT has not changed state. 1: UNEQP_STAT has changed state.	0
9	FEUNEQP_PEND	ROCR	Interrupt pending. Far-end unequipped path (FEUNEQP_STAT) has changed state since this register was last read. 0: FEUNEQP_STAT has not changed state. 1: FEUNEQP_STAT has changed state.	0
8	FERDIP_PEND	ROCR	Interrupt pending. Far-end path remote defect identifier (FERDIP_STAT) has changed state since this register was last read. 0: FERDIP_STAT has not changed state. 1: FERDIP_STAT has changed state.	0

Table 171 • EWIS_INTR_PEND2: E-WIS Interrupt Pending 2 (2×EF04) (continued)

Bit	Name	Access	Description	Default
7	B1_NZ_PEND	ROCR	Interrupt pending. PMTICK B1 error counter (B1_ERR_CNT) has changed from zero to a non-zero value since this register was last read. This bit does not assert if LOS or LOF are asserted at the time B1_NZ changes from 0 to 1. 0: B1_NZ_STAT has not changed from a 0 to 1 state. 1: B1_NZ_STAT has changed from a 0 to 1 state.	0
6	B2_NZ_PEND	ROCR	Interrupt pending. PMTICK B2 error counter (B2_ERR_CNT) has changed from zero to a non-zero value since this register was last read. This bit does not assert if AIS-L is asserted at the time B2_NZ changes from 0 to 1. 0: B2_NZ_STAT has not changed from a 0 to 1 state. 1: B2_NZ_STAT has changed from a 0 to 1 state.	0
5	B3_NZ_PEND	ROCR	Interrupt pending. PMTICK B3 error counter (B3_ERR_CNT) has changed from zero to a non-zero value since this register was last read. This bit does not assert if LOP-P or AIS-P are asserted at the time B3_NZ changes from 0 to 1. 0: B3_NZ_STAT has not changed from a 0 to 1 state. 1: B3_NZ_STAT has changed from a 0 to 1 state.	0
4	REIL_PEND	ROCR	Interrupt pending. REI-L changed from zero to non-zero. 0: REI-L has not received a non-zero value. 1: REI-L has received a non-zero value.	0
3	REIP_PEND	ROCR	Interrupt pending. REI-P changed from zero to non-zero. 0: REI-P has not received a non-zero value. 1: REI-P has received a non-zero value.	0
2	REIL_NZ_PEND	ROCR	Interrupt pending. PMTICK far-end B2 error counter (REIL_ERR_CNT) has changed from a zero to a non-zero value since this register was read. 0: REIL_NZ_STAT has not changed from a 0 to 1 state. 1: REIL_NZ_STAT has changed from a 0 to 1 state.	0
1	REIP_NZ_PEND	ROCR	Interrupt pending. PMTICK far-end B3 error counter (REIP_ERR_CNT) has changed from a zero to a non-zero value since this register was read. 0: REIP_NZ_STAT has changed from a 0 to 1 state. 1: REIP_NZ_STAT has changed from a 0 to 1 state.	0
0	HIGH_BER_PEND	ROCR	Interrupt pending. PCS high bit error rate (BER) condition has changed state since this register was read. 0: No change in PCS high BER condition. 1: PCS high BER condition has changed state.	0

Table 172 • EWIS_INTR_MASKA2: E-WIS Interrupt Mask A 2 (2×EF05)

Bit	Name	Access	Description	Default
15	Reserved	RO	Reserved	0
14	PMTICK_MASKA	RW	Enables propagation of PMTICK_PEND to the WIS_INTA pin 0: Disable 1: Enable	0
13	TXLOL_MASKA	RW	Enables propagation of TXLOL_PEND to the WIS_INTA pin 0: Disable 1: Enable	0
12	RXLOL_MASKA	RW	Enables propagation of RXLOL_PEND to the WIS_INTA pin 0: Disable 1: Enable	0
11	LOPC_MASKA	RW	Enables propagation of LOPC_PEND to the WIS_INTA pin 0: Disable 1: Enable	0
10	UNEQP_MASKA	RW	Enables propagation of UNEQP_PEND to the WIS_INTA pin 0: Disable 1: Enable	0
9	FEUNEQP_MASKA	RW	Enables propagation of FEUNEQP_PEND to the WIS_INTA pin 0: Disable 1: Enable	0
8	FERDIP_MASKA	RW	Enables propagation of FERDIP_PEND to the WIS_INTA pin 0: Disable 1: Enable	0
7	B1_NZ_MASKA	RW	Enables propagation of B1_NZ_PEND to the WIS_INTA pin 0: Disable 1: Enable	0
6	B2_NZ_MASKA	RW	Enables propagation of B2_NZ_PEND to the WIS_INTA pin 0: Disable 1: Enable	0
5	B3_NZ_MASKA	RW	Enables propagation of B3_NZ_PEND to the WIS_INTA pin 0: Disable 1: Enable	0
4	REIL_MASKA	RW	Enables propagation of REIL_PEND to the WIS_INTA pin 0: Disable 1: Enable	0

Table 172 • EWIS_INTR_MASKA2: E-WIS Interrupt Mask A 2 (2×EF05) (continued)

Bit	Name	Access	Description	Default
3	REIP_MASKA	RW	Enables propagation of REIP_PEND to the WIS_INTA pin 0: Disable 1: Enable	0
2	REIL_NZ_MASKA	RW	Enables propagation of REIL_NZ_PEND to the WIS_INTA pin 0: Disable 1: Enable	0
1	REIP_NZ_MASKA	RW	Enables propagation of REIP_NZ_PEND to the WIS_INTA pin 0: Disable 1: Enable	0
0	HIGH_BER_MASKA	RW	Enables propagation of HIGH_BER_PEND to the WIS_INTA pin 0: Disable 1: Enable	0

Table 173 • EWIS_INTR_MASKB2: E-WIS Interrupt Mask B 2 (2×EF06)

Bit	Name	Access	Description	Default
15	Reserved	RO	Reserved	0
14	PMTICK_MASKB	RW	Enables propagation of PMTICK_PEND to the WIS_INTB pin 0: Disable 1: Enable	0
13	TXLOL_MASKB	RW	Enables propagation of TXLOL_PEND to the WIS_INTB pin 0: Disable 1: Enable	0
12	RXLOL_MASKB	RW	Enables propagation of RXLOL_PEND to the WIS_INTB pin 0: Disable 1: Enable	0
11	LOPC_MASKB	RW	Enables propagation of LOPC_PEND to the WIS_INTB pin 0: Disable 1: Enable	0
10	UNEQP_MASKB	RW	Enables propagation of UNEQP_PEND to the WIS_INTB pin 0: Disable 1: Enable	0
9	FEUNEQP_MASKB	RW	Enables propagation of FEUNEQP_PEND to the WIS_INTB pin 0: Disable 1: Enable	0

Table 173 • EWIS_INTR_MASKB2: E-WIS Interrupt Mask B 2 (2×EF06) (continued)

Bit	Name	Access	Description	Default
8	FERDIP_MASKB	RW	Enables propagation of FERDIP_PEND to the WIS_INTB pin 0: Disable 1: Enable	0
7	B1_NZ_MASKB	RW	Enables propagation of B1_NZ_PEND to the WIS_INTB pin 0: Disable 1: Enable	0
6	B2_NZ_MASKB	RW	Enables propagation of B2_NZ_PEND to the WIS_INTB pin 0: Disable 1: Enable	0
5	B3_NZ_MASKB	RW	Enables propagation of B3_NZ_PEND to the WIS_INTB pin 0: Disable 1: Enable	0
4	REIL_MASKB	RW	Enables propagation of REIL_PEND to the WIS_INTB pin 0: Disable 1: Enable	0
3	REIP_MASKB	RW	Enables propagation of REIP_PEND to the WIS_INTB pin 0: Disable 1: Enable	0
2	REIL_NZ_MASKB	RW	Enables propagation of REIL_NZ_PEND to the WIS_INTB pin 0: Disable 1: Enable	0
1	REIP_NZ_MASKB	RW	Enables propagation of REIP_NZ_PEND to the WIS_INTB pin 0: Disable 1: Enable	0
0	HIGH_BER_MASKB	RW	Enables propagation of HIGH_BER_PEND to the WIS_INTB pin 0: Disable 1: Enable	0

Table 174 • WIS Fault Control (2×EF07)

Bit	Name	Access	Description	Default
15:11	Reserved	RW	Reserved	00111
10	WIS_FAULT_ON_FEPLM P	RW	1: Trigger WIS_FAULT 0: No trigger	0
9	WIS_FAULT_ON_FEAISP	RW	1: Trigger WIS_FAULT 0: No trigger	0
8	WIS_FAULT_ON_RDIL	RW	1: Trigger WIS_FAULT 0: No trigger	0

Table 174 • WIS Fault Control (2×EF07) (continued)

Bit	Name	Access	Description	Default
7	WIS_FAULT_ON_SEF	RW	1: Trigger WIS_FAULT 0: No trigger	1
6	WIS_FAULT_ON_LOF	RW	1: Trigger WIS_FAULT 0: No trigger	1
5	WIS_FAULT_ON_LOS	RW	1: Trigger WIS_FAULT 0: No trigger	1
4	WIS_FAULT_ON_AISL	RW	1: Trigger WIS_FAULT 0: No trigger	1
3	WIS_FAULT_ON_LCDP	RW	1: Trigger WIS_FAULT 0: No trigger	1
2	WIS_FAULT_ON_PLMP	RW	1: Trigger WIS_FAULT 0: No trigger	1
1	WIS_FAULT_ON_ASIP	RW	1: Trigger WIS_FAULT 0: No trigger	1
0	WIS_FAULT_ON_LOPP	RW	1: Trigger WIS_FAULT 0: No trigger	1

4.3 Device 3: PCS Registers

The following tables provide settings for the registers related to the PCS.

Table 175 • PCS_CTRL1: PCS Control 1 (3×0000)

Bit	Name	Access	Description	Default
15	SOFT_RST	RWSC	Reset all MMDs 0: Normal operation 1: Reset	0
14	LPBK_G	RW	Enables PCS system loopback (loopback G) 0: Disable 1: Enable XFI outputs 0×00FF	0
13	SPEED_SEL_A	RO	PCS speed capability 0: Unspecified 1: Operates at 10 Gbps or above	1
12	Reserved	RO	Reserved (value always 0, writes ignored)	0
11	LOW_PWR	RW	Enter low power mode on all MMDs 0: Normal operation 1: Low power	0
10:7	Reserved	RO	Reserved (value always 0, writes ignored)	0
6	SPEED_SEL_B	RO	PCS speed capability 0: Unspecified 1: Operates at 10 Gbps or above	1
5:2	SPEED_SEL_C	RO	PCS speed selection 1xx: Reserved x1x: Reserved xx1x: Reserved 0001: Reserved 0000: 10 Gbps	0000

Table 175 • PCS_CTRL1: PCS Control 1 (3×0000) (continued)

Bit	Name	Access	Description	Default
1:0	Reserved	RO	Reserved (value always 0, writes ignored)	0

Table 176 • PCS_STAT1: PCS Status 1 (3×0001)

Bit	Name	Access	Description	Default
15:8	Reserved	RO	Reserved (ignore when read).	0
7	FAULT	RO	PCS fault status. Asserted when either the PCS FAULT_RX (3×0008.10) or PCS FAULT_TX (3×0008.11) is asserted. 0: No faults asserted. 1: Fault asserted.	0
6:3	Reserved	RO	Reserved (ignore when read).	0
2	RX_LNK_STAT	RO/LL	PCS receive link status. 0: Link down. 1: Link up.	1
1	LOW_PWR_ABILITY	RO	Low power mode support ability. 0: Not supported. 1: Supported.	1
0	Reserved	RO	Reserved (ignore when read).	0

Table 177 • PCS_DEVID1: PCS Device Identifier 1 (3×0002)

Bit	Name	Access	Description	Default
15:0	DEV_ID_LSW	RO	Upper 16 bits of a 32-bit unique PCS device identifier. Bits 3–18 of the device manufacturer's OUI.	0×0007

Table 178 • PCS_DEVID2: PCS Device Identifier 2 (3×0003)

Bit	Name	Access	Description	Default
15:0	DEV_ID_MSW	RO	Lower 16 bits of a 32-bit unique PCS device identifier. Bits 19–24 of the device manufacturer's OUI. Six-bit model number, and a four-bit revision number.	0×0400

Table 179 • PCS_SPEED: PCS Speed Capability (3×0004)

Bit	Name	Access	Description	Default
15:1	Reserved	RO	Reserved for future speeds (value always 0, writes ignored)	0
0	RATE_ABILITY	RO	PCS rate capability 0: Not capable of 10 Gbps 1: Capable of 10 Gbps	1

Table 180 • PCS_DEVPKG1: PCS Devices in Package 1 (3×0005)

Bit	Name	Access	Description	Default
15:6	Reserved	RO	Reserved.	0
5	DTE_XS_PRES	RO	Indicates whether DTE XS is present in the package. 0: Not present. 1: Present.	0
4	PHY_XS_PRES	RO	Indicates whether PHY XS is present in the package 0: Not present. 1: Present.	1
3	PCS_PRES	RO	Indicates whether PCS is present in the package. 0: Not present. 1: Present.	1
2	WIS_PRES	RO	Indicates whether WIS is present in the package. 0: Not present. 1: Present.	1
1	PMD_PMA_PRES	RO	Indicates whether PMA/PMD is present in the package. 0: Not present. 1: Present.	1
0	CLS22_PRES	RO	Indicates whether Clause 22 registers are present in the package. 0: Not present. 1: Present.	0

Table 181 • PCS_DEVPKG2: PCS Devices in Package 2 (3×0006)

Bit	Name	Access	Description	Default
15	VS2_PRES	RO	Vendor specific device 2 present 0: Not present 1: Present	0
14	VS1_PRES	RO	Vendor specific device 1 present 0: Not present 1: Present	0
13:0	Reserved	RO	Reserved	0

Table 182 • PCS_CTRL2: PCS Control 2 (3×0007)

Bit	Name	Access	Description	Default
15:2	Reserved	RO	Reserved	0

Table 182 • PCS_CTRL2: PCS Control 2 (3×0007) (continued)

Bit	Name	Access	Description	Default
1:0	PCS_MODE	RW	Indicates the PCS type selected 11: Reserved 10: 10GBASE-W PCS 01: Reserved 00: 10GBASE-R PCS	0

Table 183 • PCS_STAT2: PCS Status 2 (3×0008)

Bit	Name	Access	Description	Default
15:14	DEV_PRES	RO	Reflects the presence of a MMD responding at this address. 00: No device responding at this address. 01: No device responding at this address. 10: Device responding at this address. 11: No device responding at this address.	10
13:12	Reserved	RO	Reserved.	0
11	FAULT_TX	RO/LH	Indicates a fault condition on the transmit path. 0: No faults asserted. 1: Fault asserted. Set error triggers with 3×E600.1. Linked to 1E×9004.3. A read to either 1E×9004.3 or 3×0008.11 clears both bits if a fault condition no longer exists.	0
10	FAULT_RX	RO/LH	Indicates a fault condition on the receive path. 0: No faults asserted. 1: Fault asserted. Set error triggers with 3×E600.0. Linked to 1E×9003.3. A read to either 1E×9003.3 or 3×0008.10 clears both bits if a fault condition no longer exists.	0
9:3	Reserved	RO	Reserved.	0
2	BASE_W_ABILITY	RO	Device capability to support 10GBASE-W. 0: Not capable. 1: Capable.	1
1	BASE_X_ABILITY	RO	Device capability to support 10GBASE-X. 0: Not capable. 1: Capable.	0
0	BASE_R_ABILITY	RO	Device capability to support 10GBASE-R. 0: Not capable. 1: Capable.	1

Table 184 • PCS_PKGID1: PCS Package Identifier 1 (3×000E)

Bit	Name	Access	Description	Default
15:0	PKG_ID_MSW	RO	Upper 16 bits of a 32-bit unique PCS package identifier. Bits 3–18 of the device manufacturer's OUI.	0

Table 185 • PCS_PKGID2: PCS Package Identifier 2 (3×000F)

Bit	Name	Access	Description	Default
15:0	PKG_ID_LSW	RO	Lower 16 bits of a 32-bit unique PCS package identifier. Bits 19–24 of the device manufacturer's OUI. Six-bit model number, and a four-bit revision number.	0

Table 186 • PCS_10GBASEX_STAT: PCS 10G BASE-X Status (3×0018)

Bit	Name	Access	Description	Default
15:0	BASE_X_STAT	RO	This device does not implement 10GBASE-X.	0

Table 187 • PCS_10GBASEX_CTRL: PCS 10G BASE-X Control (3×0019)

Bit	Name	Access	Description	Default
15:0	BASE_X_CTRL	RO	This device does not implement 10GBASE-X.	0

Table 188 • PCS_10GBASER_STAT1: PCS 10G BASE-R Status 1 (3×0020)

Bit	Name	Access	Description	Default
15:13	Reserved	RO	Reserved.	0
12	BASE_R_RXLCK_STAT	RO	10GBASE-R receive link status. This does not apply during PCS pattern testing. 0: Link down. 1: Link up.	0
11:3	Reserved	RO	Reserved.	0
2	PRBS31_ABILITY	RO	PCS PRBS31 pattern test capability. 0: Not capable. 1: Capable.	1
1	HIGH_BER	RO	10GBASE-R PCS high BER status. This does not apply during PCS pattern testing. 0: High BER deasserted. 1: High BER asserted.	0
0	BLOCK_LOCK	RO	10GBASE-R PCS block lock status. This does not apply during PCS pattern testing. 0: Not locked. 1: Locked.	0

Table 189 • PCS_10GBASER_STAT2: PCS 10G BASE-R Status 2 (3×0021)

Bit	Name	Access	Description	Default
15	BLOCK_LOCK_LATCHED	RO/LL	Latched block lock status. 0: 10GBASE-R PCS does not have block lock. 1: 10GBASE-R PCS has block lock.	1
14	HIGH_BER_LATCHED	RO/LH	Latched high BER status. 0: 10GBASE-R PCS has not reported a high BER. 1: 10GBASE-R PCS has reported a high BER.	0
13:8	BER_CNT	ROCR	Saturating (non-rollover) clear on read BER counter. This does not apply during PCS pattern testing.	0
7:0	ERR_BLK_CNT	ROCR	Saturating (non-rollover) clear on read errored block counter. This does not apply during PCS pattern testing.	0

Table 190 • PCS_SEEDA3: PCS Test Pattern Seed A 3 (3×0022)

Bit	Name	Access	Description	Default
15:0	TSTPAT_SEEDA_15_0	RW	Bits 15:0 of the 58-bit seed A test pattern. Used during PCS pseudo-random test.	0

Table 191 • PCS_SEEDA2: PCS Test Pattern Seed A 2 (3×0023)

Bit	Name	Access	Description	Default
15:0	TSTPAT_SEEDA_31_16	RW	Bits 31:16 of the 58-bit seed A test pattern. Used during PCS pseudo-random test.	0

Table 192 • PCS_SEEDA1: PCS Test Pattern Seed A 1 (3×0024)

Bit	Name	Access	Description	Default
15:0	TSTPAT_SEEDA_47_32	RW	Bits 47:32 of the 58-bit seed A test pattern. Used during PCS pseudo-random test.	0

Table 193 • PCS_SEEDA0: PCS Test Pattern Seed A 0 (3×0025)

Bit	Name	Access	Description	Default
15:10	Reserved	RO	Reserved	0
9:0	TSTPAT_SEEDA_57_48	RW	Bits 57:48 of the 58-bit seed A test pattern. Used during PCS pseudo-random test.	0

Table 194 • PCS_SEEDB3: PCS Test Pattern Seed B 3 (3×0026)

Bit	Name	Access	Description	Default
15:0	TSTPAT_SEEDB_15_0	RW	Bits 15:0 of the 58-bit seed B test pattern. Used during PCS pseudo-random test.	0

Table 195 • PCS_SEEDB2: PCS Test Pattern Seed B 2 (3×0027)

Bit	Name	Access	Description	Default
15:0	TSTPAT_SEEDB_31_16	RW	Bits 31:16 of the 58-bit seed B test pattern. Used during PCS pseudo-random test.	0

Table 196 • PCS_SEEDB1: PCS Test Pattern Seed B 1 (3×0028)

Bit	Name	Access	Description	Default
15:0	TSTPAT_SEEDB_47_32	RW	Bits 47:32 of the 58-bit seed B test pattern. Used during PCS pseudo-random test.	0

Table 197 • PCS_SEEDB0: PCS Test Pattern Seed B 0 (3×0029)

Bit	Name	Access	Description	Default
15:10	Reserved	RO	Reserved	0
9:0	TSTPAT_SEEDB_57_48	RW	Bits 57:48 of the 58-bit seed B test pattern. Used during PCS pseudo-random test.	0

Table 198 • PCS_TSTPAT_CTRL: PCS Test Pattern Control (3×002A)

Bit	Name	Access	Description	Default
15:6	Reserved	RO	Reserved	0
5	PCS_PRBS31_ANAL	RW	Enables PRBS31 test pattern analysis 0: Disable 1: Enable	0
4	PCS_PRBS31_GEN	RW	Enables PRBS31 test pattern generation 0: Disable 1: Enable	0
3	PCS_TSTPAT_GEN	RW	Enables PCS test pattern generator 0: Disable 1: Enable	0
2	PCS_TSTPAT_ANA	RW	Enables PCS test pattern analyzer 0: Disable 1: Enable	0

Table 198 • PCS_TSTPAT_CTRL: PCS Test Pattern Control (3×002A) (continued)

Bit	Name	Access	Description	Default
1	PCS_TSTPAT_SEL	RW	Selects which test pattern to be used during the PCS_TSTPAT_GEN/ANA 0: Pseudo-Random 1: Square Wave (generation only)	0
0	PCS_TSTDAT_SEL	RW	Data to be sent during the pseudo-random pattern test after the loading of seed A or seed B 0: 64-bit encoding for 2 local fault ordered sets 1: 64 zeros	0

Table 199 • PCS_TSTPAT_CNT: PCS Test Pattern Error Counter (3×002B)

Bit	Name	Access	Description	Default
15:0	Test error counter	ROCR	Clear on read test pattern error counter. A 32-bit version of this counter is available in 3×8007–3×8008. This counter is a saturating counter.	0

Table 200 • PCS_USRPAT0: PCS User Test Pattern 0 (3×8000)

Bit	Name	Access	Description	Default
15:0	TSTPAT_USR_15_0	RW	Bits 15:0 of the 64-bit user pattern to be sent instead of local fault ordered sets during pseudo-random testing. Active when 3×8005.0 is asserted.	0

Table 201 • PCS_USRPAT1: PCS User Test Pattern 1 (3×8001)

Bit	Name	Access	Description	Default
15:0	TSTPAT_USR_31_16	RW	Bits 31:16 of the 64-bit user pattern to be sent instead of local fault ordered sets during pseudo-random testing. Active when 3×8005.0 is asserted.	0

Table 202 • PCS_USRPAT2: PCS User Test Pattern 2 (3×8002)

Bit	Name	Access	Description	Default
15:0	TSTPAT_USR_47_32	RW	Bits 47:22 of the 64-bit user pattern to be sent instead of local fault ordered sets during pseudo-random testing. Active when 3×8005.0 is asserted.	0

Table 203 • PCS_USRPAT3: PCS User Test Pattern 3 (3×8003)

Bit	Name	Access	Description	Default
15:0	TSTPAT_USR_63_48	RW	Bits 63:48 of the 64-bit user pattern to be sent instead of local fault ordered sets during pseudo-random testing. Active when 3×8005.0 is asserted	0

Table 204 • PCS_SQPW_CTRL: PCS Square Wave Pulse Width Control (3×8004)

Bit	Name	Access	Description	Default
15:4	Reserved	RO	Reserved	0
3:0	SQ_WV_PW	RW	Pulse width of the generated square wave test pattern. This is the number of consecutive low bit times and the number of consecutive high bit times. Only values of 4 through 11 bits are valid.	0

Table 205 • PCS_CFG1: PCS Configuration 1 (3×8005)

Bit	Name	Access	Description	Default
15:11	Reserved	RO	Reserved	0
10	DSCR_DIS	RW	Disable Rx block descrambler 0: Enable 1: Disable	0
9	SCR_DIS	RW	Disable Tx block scrambler 0: Enable 1: Disable	0
8	Reserved	RW	Reserved; set bit to 0 only	0
7	Reserved	RW	Reserved; set bit to 1 only	1
6	Reserved	RW	Reserved; set bit to 0 only	0
5:4	Reserved	RW	Factory test only; do not modify	0
3	LPBK_F	RW	Enables loopback F (PCS network loopback) 0: Disable 1: Enable	0
2	LPBK_E	RW	Enables loopback E (PCS system loopback) 0: Disable 1: Enable	0
1	Reserved	RO	Reserved	0
0	USR_PAT_EN	RW	Selects the user test pattern in 3×8000 to 3×8003 for pseudo-random test 0: Standard test pattern 1: User test pattern	0

Table 206 • PCS_ERR_CNT0: PCS Test Error Counter 0 (3×8007)

Bit	Name	Access	Description	Default
15:0	TSTPAT_ERR_CNT 0	RO	Lower 16 bits of the 32-bit test error counter. This counter is a saturating (non-rollover) counter that is cleared upon a consecutive read to 3×8007 and 3×8008. The contents of this register are identical to 3×002B.	0

Table 207 • PCS_ERR_CNT1: PCS Test Error Counter 1 (3×8008)

Bit	Name	Access	Description	Default
15:0	TSTPAT_ERR_CNT 1	RO	Upper 16 bits of the 32-bit test error counter. This counter is a saturating (non-rollover) counter that is cleared upon a consecutive read to 3×8007 and 3×8008.	0

Table 208 • Factory Test Register (3×8009)

Bit	Name	Access	Description	Default
15:0	Reserved	RO	Factory test only; do not modify	0

Table 209 • Factory Test Register (3×800C)

Bit	Name	Access	Description	Default
15:0	Reserved	ROCR	Factory test only; do not modify	0

Table 210 • Factory Test Register (3×800D)

Bit	Name	Access	Description	Default
15:0	Reserved	ROCR	Factory test only; do not modify	0

Table 211 • Factory Test Register (3×800E)

Bit	Name	Access	Description	Default
15:0	Reserved	ROCR	Factory test only; do not modify	0

Table 212 • Factory Test Register (3×800F)

Bit	Name	Access	Description	Default
15:0	Reserved	ROCR	Factory test only; do not modify	0

Table 213 • Factory Test Register (3×8010)

Bit	Name	Access	Description	Default
15:0	Reserved	ROCR	Factory test only; do not modify	0

Table 214 • Factory Test Register (3×8011)

Bit	Name	Access	Description	Default
15:0	Reserved	ROCR	Factory test only; do not modify	0

Table 215 • Factory Test Register (3×8012)

Bit	Name	Access	Description	Default
15:0	Reserved	ROCR	Factory test only; do not modify	0

Table 216 • Factory Test Register (3×8013)

Bit	Name	Access	Description	Default
15:0	Reserved	ROCR	Factory test only; do not modify	0

Table 217 • Factory Test Register (3×8014)

Bit	Name	Access	Description	Default
15:0	Reserved	ROCR	Factory test only; do not modify	0

Table 218 • Factory Test Register (3×8015)

Bit	Name	Access	Description	Default
15:0	Reserved	ROCR	Factory test only; do not modify	0

Table 219 • PCS_CFG2: PCS Configuration 2 (3×E600)

Bit	Name	Access	Description	Default
15:3	Reserved	RO	Reserved	0
2	PR58_INV_DIS	RW	Disable the periodic inversion of the pseudo-random test pattern for both transmit and receive paths 0: Enable 1: Disable	0

Table 219 • PCS_CFG2: PCS Configuration 2 (3×E600) (continued)

Bit	Name	Access	Description	Default
1	FAULT_TX_SEL	RW	Selects error types to trigger a transmit fault 0: FIFO over/underflow condition only 1: Character encoding error, block encoding error, FIFO over/underflow condition	0
0	RX_STAT_SEL	RW	Selects contributing logic for receive link status 0: BLOCK_LOCK = 1 1: BLOCK_LOCK = 1 and HIGH_BER = 0	0

Table 220 • Factory Test Register (3×E601)

Bit	Name	Access	Description	Default
15:0	Reserved	RO	Factory test only; do not modify	0

Table 221 • Factory Test Register (3×E602)

Bit	Name	Access	Description	Default
15:0	Reserved	RO	Factory test only; do not modify	0

Table 222 • Factory Test Register (3×E603)

Bit	Name	Access	Description	Default
15:0	Reserved	RW	Factory test only; do not modify	0

Table 223 • EPCS_STAT1: E-PCS Status 1 (3×E604)

Bit	Name	Access	Description	Default
15:8	Reserved	RO	Reserved	0
7:5	LSM_TX_STATE	RO	Current Tx LSM state	0
4	LSM_RX_STAT	RO	Status of Rx framing 0: E-PCS is not framed 1: E-PCS is framed	0
3	RX_MSG_RDY	ROCR	Notification that a new HDLC message has been received 0: No change to HDLC frame 1: New HDLC frame received	0
2:0	LSM_RX_STATE	RO	Current Rx LSM state	0

Table 224 • EPCS_CORR_CNT: E-PCS Corrected FEC Error Counter (3×E605)

Bit	Name	Access	Description	Default
15:0	CORR_ERR_CNT T	RO	Count of corrected E-PCS frames over the previous second. Counter is reset every second. Counter is not cumulative and does not roll over. Saturating (non-rollover) counter is cleared by assertion of CLR_CNT. Cleared when 3×E601.1 is set.	0

Table 225 • EPCS_UCORR_CNT: E-PCS UnCorrected FEC Error Counter (3×E606)

Bit	Name	Access	Description	Default
15:0	UNCORR_ERR_CNT T	RO	Count of corrected E-PCS frames over the previous second. Counter is reset every second. Counter is not cumulative and does not roll over. Saturating (non-rollover) counter is cleared by assertion of CLR_CNT. Cleared when 3×E601.1 is set.	0

Table 226 • EPCS_TXMSG: E-PCS Tx Message (3×E60A-E611)

Bit	Name	Access	Description	Default
15:0	TX_MSG	RW	128-bit message for in-band transmission to the far end link partner. The 3×E60A is the MSW while 3×E611 is the LSW.	0

Table 227 • EPCS_RXMSG: E-PCS Rx Message (3×E612-E619)

Bit	Name	Access	Description	Default
15:0	RX_MSG	RO	128-bit message received from the far end link partner. Frame delineation is not supported, thus higher level software must determine the MSW.	0

Table 228 • Factory Test Register (3×E61A)

Bit	Name	Access	Description	Default
15:3	Reserved	RO	Factory test only; do not modify	0
2:0	Reserved	RW	Factory test only; do not modify	0

Table 229 • Factory Test Register (3×E61B)

Bit	Name	Access	Description	Default
15:8	Reserved	RW	Factory test only; do not modify	0×10
7:0	Reserved	RW	Factory test only; do not modify	0×14

Table 230 • Factory Test Register (3×E61C)

Bit	Name	Access	Description	Default
15:0	Reserved	RO	Factory test only; do not modify	0

Table 231 • Factory Test Register (3×E61D)

Bit	Name	Access	Description	Default
15:0	Reserved	RO	Factory test only; do not modify	0

4.4 Device 4: PHY-XS Registers

The following tables provide settings for the registers related to the PHY-XS.

Table 232 • PHYXS_CTRL1: PHY XS Control 1 (4×0000)

Bit	Name	Access	Description	Default
15	SOFT_RST	RWSC	Reset all MMDs 0: Normal operation. 1: Reset	0
14	LPBK_A	RW	Enables PHY XS network loopback (loopback A) 0: Disable 1: Enable Register 4×E600.1 must be set to 1 to enable loopback A.	0
13	SPEED_SEL_A	RO	PHY XS speed capability 0: Unspecified 1: Operates at 10 Gbps or above	1
12	Reserved	RO	Reserved (value always 0, writes ignored)	0
11	LOW_PWR	RW	PHY XS low power mode control 0: Normal operation 1: Low Power	0
10:7	Reserved	RO	Reserved (value always 0, writes ignored)	0
6	SPEED_SEL_B	RO	PHY XS Speed capability 0: Unspecified 1: Operates at 10 Gbps or above	1

Table 232 • PHYXS_CTRL1: PHY XS Control 1 (4×0000) (continued)

Bit	Name	Access	Description	Default
5:2	SPEED_SEL_C	RO	PHY XS speed selection 1xx: Reserved x1xx: Reserved xx1x: Reserved 0001: Reserved 0000: 10 Gbps	0
1:0	Reserved	RO	Reserved (value always 0, writes ignored)	0

Table 233 • PHYXS_STAT1: PHY XS Status1 (4×0001)

Bit	Name	Access	Description	Default
15:8	Reserved	RO	Reserved (ignore when read)	0
7	FAULT	RO	PHY XS fault status. Asserted when either the PHY XS FAULT_RX (4×0008.10) or PHY XS FAULT_TX (4×0008.11) is asserted. 0: No faults asserted. 1: Fault asserted.	0
6:3	Reserved	RO	Reserved (ignore when read)	0
2	TX_LNK_STAT	RO/LL	PHY XS transmit link status 0: PHY XS transmit link is down (4×0018.12 = 0) 1: PHY XS transmit link is up (4×0018.12 = 1)	1
1	LOW_PWR_ABILITY	RO	Low power mode support ability 0: Not supported 1: Supported	1
0	Reserved	RO	Reserved (ignore when read)	0

Table 234 • PHYXS_DEVID1: PHY XS Device Identifier 1 (4×0002)

Bit	Name	Access	Description	Default
15:0	DEV_ID_LSW	RO	Upper 16 bits of a 32-bit unique PHY XS device identifier. Bits 3–18 of the device manufacturer's OUI. Device identifier bits 31:16.	0×0007

Table 235 • PHYXS_DEVID2: PHY XS Device Identifier 2 (4×0003)

Bit	Name	Access	Description	Default
15:0	DEV_ID_MSW	RO	Lower 16 bits of a 32-bit unique PHY XS device identifier. Bits 19–24 of the device manufacturer's OUI. Six-bit model number, and a four-bit revision number. Device identifier bits 15:0.	0×0400

Table 236 • PHYXS_SPEED: PHY XS Speed Capability (4×0004)

Bit	Name	Access	Description	Default
15:1	Reserved	RO	Reserved for future speeds (value always 0, writes ignored)	0
0	RATE_ABILITY	RO	PHY XS rate capability 0: Not capable of 10 Gbps 1: Capable of 10 Gbps	1

Table 237 • PHYXS_DEVPKG1: PHY XS Devices in Package 1 (4×0005)

Bit	Name	Access	Description	Default
15:6	Reserved	RO	Reserved (ignore when read).	0
5	DTE_XS_PRE	RO	Indicates whether device includes DTS XS. 0: Not present. 1: Present.	0
4	PHY_XS_PRE	RO	Indicates whether device includes PHY XS. 0: Not present. 1: Present.	1
3	PCS_PRE	RO	Indicates whether PCS is present in the package. 0: Not present. 1: Present.	1
2	WIS_PRE	RO	Indicates whether WIS is present in the package. 0: Not present. 1: Present.	1
1	PMD_PMA_PRES	RO	Indicates whether PMA/PMD is present in the package. 0: Not present. 1: Present.	1
0	CLS22_PRE	RO	Indicates whether Clause 22 registers are present in the package. 0: Not present. 1: Present.	0

Table 238 • PHYXS_DEVPKG2: PHY XS Devices in Package 2 (4×0006)

Bit	Name	Access	Description	Default
15	VS2_PRE	RO	Vendor specific device 2 present 0: Not present 1: Present	0
14	VS1_PRE	RO	Vendor specific device 1 present 0: Not present 1: Present	0
13:0	Reserved	RO	Reserved (ignore when read)	0

Table 239 • PHYXS_STAT2: PHY XS Status 2 (4×0008)

Bit	Name	Access	Description	Default
15:14	DEV_PRESENCE	RO	Reflects the presence of a MMD responding at this address. 10: Device responding at this address. 11: No device responding at this address. 10: No device responding at this address. 00: No device responding at this address.	10
13:12	Reserved	RO	Reserved (ignore when read).	0
11	FAULT_TX	RO/LH	Indicates a fault condition on the transmit path. 0: No fault condition. XGXS lanes are aligned, 4×0018.12 = 1. 1: Fault condition. XGXS lanes are not aligned, 4×0018.12 = 0. Linked to 1E×9004.0. Read to either register clears both bits if fault condition no longer exists.	0
10	FAULT_RX	RO/LH	Indicates a fault condition on the receive path. 0: Rx PCS block is locked to the data, and is not reporting a high bit error rate. 1: Rx PCS block is not locked to the data, or is reporting a high bit error rate.	0
9:0	Reserved	RO	Reserved (ignore when read).	0

Table 240 • PHYXS_STAT3: PHY XS Status 3 (4×0018)

Bit	Name	Access	Description	Default
15:13	Reserved	RO	Reserved (ignore when read)	0
12	LANES_ALIGNED	RO	PHY XGXS lane alignment status 0: PHY XS transmit lanes are not aligned 1: PHY XS transmit lanes are aligned	0
11	PATT_ABILITY	RO	PHY XGXS test pattern generation ability 0: PHY XS is not able to generate test patterns 1: PHY XS is able to generate test patterns	1
10	LPBK_ABILITY	RO	PHY XGXS loopback ability 0: PHY XS does not have the ability to perform a loopback function 1: PHY XS has the ability to perform a loopback function	1
9:4	Reserved	RO	Reserved (ignore when read)	0
3	LANE3_SYNC	RO	PHY XGXS lane 3 synchronization status 0: Not synchronized 1: Synchronized	0
2	LANE2_SYNC	RO	PHY XGXS lane 2 synchronization status 0: Not synchronized 1: Synchronized	0
1	LANE1_SYNC	RO	PHY XGXS lane 1 synchronization status 0: Not synchronized 1: Synchronized	0

Table 240 • PHYXS_STAT3: PHY XS Status 3 (4×0018) (continued)

Bit	Name	Access	Description	Default
0	LANE0_SYNC	RO	PHY XGXS lane 0 synchronization status 0: Not synchronized 1: Synchronized	0

Table 241 • PHYXS_TSTCTRL1: PHY XGXS Test Control 1 (4×0019)

Bit	Name	Access	Description	Default
15:3	Reserved	RO	Reserved (value always 0, writes ignored)	0
2	TST_PATT_CHK_EN A	RW	PHYXS test pattern checker enable 0: Disable 1: Enable	0
1:0	TST_PATT_CHK_SE L	RW	PHYXS test pattern checker pattern select 111: 2 ⁷ PRBS Pattern 110: Fibre Channel CJPAT 101: Continuous jitter test pattern 100: Continuous random test pattern 011: Disable pattern generator 010: Mixed frequency test pattern 001: Low frequency test pattern 000: High frequency test pattern MSB is 4×8000.3. Additionally, two types of CJPAT patterns are provided. For more information, see Table 265 , page 169.	0

Table 242 • PHYXS_TSTCTRL2: PHY XS Test Control 2 (4×8000)

Bit	Name	Access	Description	Default
15:5	Reserved	RO	Reserved	0
4	TST_PATT_GEN_EN A	RW	PHYXS test pattern generator enable 0: Disable 1: Enable	0
3	TST_PATT_MODE	RW	Transmit test pattern checker select bit 2 Use with register 4×0019.1:0	0
2:0	TST_PATT_GEN_SE L	RW	PHYXS test pattern generator select 111: 2 ⁷ PRBS pattern 110: Fibre Channel CJPAT 101: Continuous jitter test pattern 100: Continuous random test pattern 011: Disable pattern generator 010: Mixed frequency test pattern 001: Low frequency test pattern 000: High frequency test pattern Two types of CJPAT patterns are provided. For more information, see Table 265 , page 169.	011

Table 243 • PHYXS_TSTSTAT: PHY XS Test Pattern Check Status (4×8001)

Bit	Name	Access	Description	Default
15:4	Reserved	RO	Reserved	0
3	LANE3_PATT_CHK	RO	Lane 3 test pattern check result 0: Pattern check fail 1: Pattern check pass	0
2	LANE2_PATT_CHK	RO	Lane 2 test pattern check result 0: Pattern check fail 1: Pattern check pass	0
1	LANE1_PATT_CHK	RO	Lane 1 test pattern check result 0: Pattern check fail 1: Pattern check pass	0
0	LANE0_PATT_CHK	RO	Lane 0 test pattern check result 0: Pattern check fail 1: Pattern check pass	0

Table 244 • Factory Test Register (4×8002)

Bit	Name	Access	Description	Default
15:0	Reserved	RO	Factory test only; do not modify	0

Table 245 • Factory Test Register (LSW) (4×8003)

Bit	Name	Access	Description	Default
15:0	Reserved	RO	Factory test only; do not modify	0

Table 246 • Factory Test Register (4×8004)

Bit	Name	Access	Description	Default
15:0	Reserved	RO	Factory test only; do not modify	0

Table 247 • Factory Test Register (4×8005)

Bit	Name	Access	Description	Default
15:0	Reserved	RO	Factory test only; do not modify	0

Table 248 • Factory Test Register (4×8006)

Bit	Name	Access	Description	Default
15:0	Reserved	RO	Factory test only; do not modify	0

Table 249 • Factory Test Register (4×8007)

Bit	Name	Access	Description	Default
15:0	Reserved	RO	Factory test only; do not modify	0

Table 250 • Factory Test Register (4×8008)

Bit	Name	Access	Description	Default
15:0	Reserved	RO	Factory test only; do not modify	0

Table 251 • Factory Test Register (4×8009)

Bit	Name	Access	Description	Default
15:0	Reserved	RO	Factory test only; do not modify	0

Table 252 • Factory Test Register (4×800A)

Bit	Name	Access	Description	Default
15:0	Reserved	RO	Factory test only; do not modify	0

Table 253 • PHYXS_TPERR_CTRL: PHY XS Test Pattern Error Counter Control (4×800B)

Bit	Name	Access	Description	Default
15:5	Reserved	RO	Reserved	0
4	TP_CNT_CLR	RWSC	Clear test pattern mismatch error counter 0: Normal operation 1: Clear counter	0
3	TP_CNT_ENA	RW	Test pattern mismatch error counter enable 0: Disable 1: Enable	1
2:0	TP_CNT_SEL	RW	Selects test pattern mismatch error source 111: Reserved 110: Reserved 101: Reserved 100: Cumulative error count on all lanes 011: Error count on lane 3 010: Error count on lane 2 001: Error count on lane 1 000: Error count on lane 0	100

Table 254 • PHYXS_TPERR_CNT0: PHY XS Test Pattern Error Counter 0 (LSW) (4×800C)

Bit	Name	Access	Description	Default
15:0	TP_CNT_LSW	RO	Test pattern mismatch error counter. Lower 16-bits of the saturating (non-rollover) counter. Saturating counter.	0

Table 255 • PHYXS_TPERR_CNT0: PHY XS Test Pattern Error Counter 1 (MSW) (4×800D)

Bit	Name	Access	Description	Default
15:0	TP_CNT_MSW	RO	Test pattern mismatch error counter. Upper 16-bits of the saturating (non-rollover) counter. Saturating counter.	0

Table 256 • PHYXS_XAUI_CTRL1: PHY XS XAUI Control 1 (4×800E)

Bit	Name	Access	Description	Default
15:14	Reserved	RO	Reserved.	0
13	LPBK_B	RW	Loopback B enable (PHY XS shallow system). 0: Disable. 1: Enable. High-speed transmitter outputs transmit data. Use register 1×EF10 to select options to transmit all ones, all zeros, 0×00FF pattern, or XAUI data.	0
12	Reserved	RWSC	Factory test only; do not modify.	1
11	Reserved	RO	Factory test only; do not modify.	1
10:9	Reserved	RO	Factory test only; do not modify.	0
8:5	RX_SQUELCH_XAUI	RW	Force receive XAUI data to zero (bit 8 corresponds to lane 3, and bit 5 corresponds to lane 0). 0: Normal operation. 1: Force data to zero.	0
4	Reserved	RO	Factory test only; do not modify.	0
3	Reserved	RW	Factory test only; do not modify.	0
2:1	Reserved	RO	Reserved.	0
0	Reserved	RW	Factory test only; do not modify.	0

Table 257 • PHYXS_XAUI_CTRL2: PHY XS XAUI Control 2 (4×800F)

Bit	Name	Access	Description	Default
15:13	Reserved	RO	Reserved	0
12:11	Reserved	RW	Factory test only; do not modify	0

Table 257 • PHYXS_XAUI_CTRL2: PHY XS XAUI Control 2 (4×800F) (continued)

Bit	Name	Access	Description	Default
10	RX_LANE_SWAP	RW	Swaps receive lane 0 with lane 3 and lane 1 with lane 2 0: Enable 1: Disable	1
9	TX_LANE_SWAP	RW	Swaps transmit lane 0 with lane 3 and lane 1 with lane 2 0: Enable 1: Disable	1
8:7	Reserved	RW	Factory test only; do not modify	0
6	RX_INV	RW	Disable XAUI input (receive) data invert 0: Enable 1: Disable	1
5	TX_INV	RW	Disable XAUI output (transmit) data invert 0: Enable 1: Disable	1
4	Reserved	RO	Reserved	0
3	Reserved	RW	Factory test only; do not modify	0
2	LPBK_C	RW	Enables loopback C (XAUI side loopback after 8b/10b) 0: Disable 1: Enable	0
1	LPBK_D	RW	Enables loopback D (XFI side loopback after 8b/10b) 0: Disable 1: Enable	0
0	Reserved	RW	Factory test only; do not modify	0

Table 258 • PHYXS_RXEQ_CTRL: PHY XS XAUI Rx Equalization Control (4×8010)

Bit	Name	Access	Description	Default
15:12	LANE0_EQ	RW	Equalization setting for XAUI input lane 0 0000: 0 dB 0001: 1.41 dB 0010: 2.24 dB 0011: 2.83 dB 0101: 4.48 dB 0110: 5.39 dB 0111: 6.07 dB 1001: 6.18 dB 1010: 7.08 dB 1011: 7.79 dB 1101: 9.96 dB 1110: 10.84 dB 1111: 11.55 dB	0
11:8	LANE1_EQ	RW	Equalization setting for XAUI input lane 1 Refer to bits [15:12] for settings	0
7:4	LANE2_EQ	RW	Equalization setting for XAUI input lane 2 Refer to bits [15:12] for settings	0

Table 258 • PHYXS_RXEQ_CTRL: PHY XS XAUI Rx Equalization Control (4×8010) (continued)

Bit	Name	Access	Description	Default
3:0	LANE3_EQ	RW	Equalization setting for XAUI input lane 3 Refer to bits [15:12] for settings	0

Table 259 • PHYXS_TXPE_CTRL: PHY XS XAUI Tx Pre-Emphasis Control (4×8011)

Bit	Name	Access	Description	Default
15	Reserved	RO	Reserved.	0
14:13	LANE0_PE	RW	Pre-Emphasis setting for XAUI output lane 0. 00: 0 dB. 01: ~2.5 dB. 10: ~6 dB. 11: ~12 dB.	0
12	Reserved	RO	Reserved.	0
11:10	LANE1_PE	RW	Pre-Emphasis setting for XAUI output lane 1. Refer to bits [14:13] for settings.	0
9	Reserved	RO	Reserved.	0
8:7	LANE2_PE	RW	Pre-Emphasis setting for XAUI output lane 2. Refer to bits [14:13] for settings.	0
6	Reserved	RO	Reserved.	0
5:4	LANE3_PE	RW	Pre-Emphasis setting for XAUI output lane 3. Refer to bits [14:13] for settings.	0
3:2	LOS_THRES	RW	The following estimated settings can be used for various LOS_THRES. 11: 80 mV to 205 mV differential peak-to-peak. 10: 70 mV to 195 mV differential peak-to-peak. 01: 60 mV to 185 mV differential peak-to-peak. 00: 50 mV to 175 mV differential peak-to-peak.	0
1	HS_ENA	RW	Enables XAUI output high swing mode. 0: Disable. 1: Enable. Low swing mode is recommended, because there is no significant output amplitude difference between high swing mode and low swing mode.	0
0	Reserved	RO	Reserved.	0

Table 260 • PHYXS_RXLOS_STAT: PHY XS Rx Loss of Signal Status (4×8012)

Bit	Name	Access	Description	Default
15:7	Reserved	RO	Reserved	0
6	GLBL_SYNC	RO	PHY XS code group synchronization status 0: At least one lane is not in sync 1: All lanes are in sync	0
5	XS_LOL	RO	PHY XS PLL loss of lock 0: PLL in lock 1: PLL loss of lock	0

Table 260 • PHYXS_RXLOS_STAT: PHY XS Rx Loss of Signal Status (4×8012) (continued)

Bit	Name	Access	Description	Default
4	Reserved	RO	Reserved	0
3	LANE3_LOS	RO	Loss of signal status for lane 3 XAUI input ¹ 0: Lane 3 signal present 1: Lane 3 loss of signal.	0
2	LANE2_LOS	RO	Loss of signal status for lane 2 XAUI input ¹ 0: Lane 2 signal present 1: Lane 2 loss of signal	0
1	LANE1_LOS	RO	Loss of signal status for lane 1 XAUI input ¹ 0: Lane 1 signal present 1: Lane 1 loss of signal	0
0	LANE0_LOS	RO	Loss of signal status for lane 0 XAUI input ¹ 0: Lane 0 signal present 1: Lane 0 loss of signal	0

1. While there is no issue on the actual data path, this real time detection signal can chatter when the amplitude of the input signal is larger than 1200 mV or the equivalent frequency is above 1.6 GHz.

Table 261 • PHYXS_RXSD_STAT: PHY XS Rx Signal Detect Status (4×E600)

Bit	Name	Access	Description	Default
15:2	Reserved	RO	Factory test only; do not modify	0
1	GLBL_SIG_DET	RW	Disable signal detect function of all XAUI inputs 0: Enabled 1: Disabled When no signal is connected to XAUI bus, set this bit to 1 for proper loopback A function.	0
0	SIG_DET	RO	Global signal detect status 0: No signal detected in at least one lane 1: Signal detected in all lanes	N/A

Table 262 • Factory Test Register (4×E601)

Bit	Name	Access	Description	Default
15:9	Reserved	RO	Reserved	0
8	Reserved	RW	Factory test only; do not modify	0
7:0	Reserved	RW	Factory test only; do not modify	0×01

Table 263 • PHYXS_TXPD_CTRL: PHY XS XAUI Tx Power Down Control (4×E602)

Bit	Name	Access	Description	Default
15	Reserved	RO	Reserved	0

Table 263 • PHYXS_TXPD_CTRL: PHY XS XAUI Tx Power Down Control (4×E602) (continued)

Bit	Name	Access	Description	Default
14	LANE3_TX_PD	RW	Power down XAUI lane 3 from the system host into the VSC8486-11 device 0: Powered up 1: Powered down Not changed with lane swap control (4×800F)	0
13	LANE2_TX_PD	RW	Power down XAUI lane 2 from the system host into the VSC8486-11 device 0: Powered up 1: Powered down Not changed with lane swap control (4×800F)	0
12	LANE1_TX_PD	RW	Power down XAUI lane 1 from the system host into the VSC8486-11 device 0: Powered up 1: Powered down Not changed with lane swap control (4×800F)	0
11	LANE0_TX_PD	RW	Power down XAUI lane 0 from the system host into the VSC8486-11 device 0: Powered up 1: Powered down Not changed with lane swap control (4×800F)	0
10:9	LPBK_B_CLK	RW	Selects which of the four recovered clocks will be used for loopback B (PHY XS shallow system loopback) 11: Lane 3 10: Lane 2 01: Lane 1 00: Lane 0	0
8	LPBK_B_CLKSEL	RW	Enables automatic clock selection for loopback B and select which of the four recovered XAUI receive lane clocks will be used to retime the transmit data 0: Manual select (see bits 10:9) 1: Auto select	1
7:0	Reserved	RO	Factory test only; do not modify	0

Table 264 • PHYXS_RXPD_CTRL: PHY XS XAUI Rx Power Down Control (4×E603)

Bit	Name	Access	Description	Default
15:10	Reserved	RO	Reserved	0
9	Reserved	RW	Factory test only; do not modify	0
8	Reserved	RW	Factory test only; do not modify	1
7	LANE3_RX_PD	RW	Power down XAUI lane 3 from the VSC8486-11 device into the system host 0: Powered up 1: Powered down	0

Table 264 • PHYXS_RXPD_CTRL: PHY XS XAUI Rx Power Down Control (4×E603) (continued)

Bit	Name	Access	Description	Default
6	LANE2_RX_PD	RW	Power down XAUI lane 2 from the VSC8486-11 device into the system host 0: Powered up 1: Powered down	0
5	LANE1_RX_PD	RW	Power down XAUI lane 1 from the VSC8486-11 device into the system host 0: Powered up 1: Powered down	0
4	LANE0_RX_PD	RW	Power down XAUI lane 0 from the VSC8486-11 device into the system host 0: Powered up 1: Powered down	0
3	LANE3_RX_SQU	RW	Force to zero PHY XS Rx lane 3 high-speed data that is output from the VSC8486-11 device 0: Output normal 1: Output squelched	0
2	LANE2_RX_SQU	RW	Force to zero PHY XS Rx lane 2 high-speed data that is output from the VSC8486-11 device 0: Output normal 1: Output squelched	0
1	LANE1_RX_SQU	RW	Force to zero PHY XS Rx lane 1 high-speed data that is output from the VSC8486-11 device 0: Output normal 1: Output squelched	0
0	LANE0_RX_SQU	RW	Force to zero PHY XS Rx lane 0 high-speed data that is output from the VSC8486-11 device 0: Output normal 1: Output squelched	0

Table 265 • FC_CJPAT_SEL (4×E604)

Bit	Name	Access	Description	Default
15:2	Reserved	RW	Reserved	0
1	FC_CJPAT_CHK_MOD3 1	RW	0: Revision 3.5 compliant CJPAT checker. 1: Revision 3.1 compliant CJPAT checker.	1
0	FC_CJPAT_GEN_MOD3 1	RW	0: Revision 3.5 compliant CJPAT generator. 1: Revision 3.1 compliant CJPAT generator.	1

Table 266 • Factory Test Register (4×E610)

Bit	Name	Access	Description	Default
15:4	Reserved	RO	Reserved	0
3:0	Reserved	RW	Factory test only; do not modify	0

4.5 Device 30: NVR and DOM Registers

The following tables provide settings for the registers related to the NVR and DOM.

Table 267 • STW_CTRL1: STW Control 1 (1E×8000)

Bit	Name	Access	Description	Default
15:13	Reserved	RO	Reserved	0
12:9	Reserved	RW	Reserved	0
8	STW_MODE	RW	Two-wire serial operating mode control. Must be set to 0. Do not write 1 to this bit. 0: Automatic mode	0
7:6	Reserved	RO	Reserved	0
5	STW_CMD	RW	Command type for automatic mode 0: Read 1: Write	0
4	Reserved	RO	Reserved	0
3:2	STW_CMD_STATU S	RO	Command status (these bits clear on read, but if a condition persists, the bits maintain their value) 00: Idle 01: Command completed successfully 10: Command in progress 11: Command failed Note: If this register becomes stuck in command-in-progress state (10), it must be restored to idle state by issuing a software reset command through register 1×EF01.15.	0
1:0	STW_EXT_CMD	RW	Extended command; the range of addressing is influenced by STW_MSA_TYPE 00: XENPAK (11–118), XFP (2–57) 01: XENPAK (119–166), XFP (72–111) 10: XENPAK (167–255), XFP (0–127) 11: XENPAK (0–255), XFP (128–255)	0

Table 268 • STW_DEVADDR: STW Device Address (1E×8002)

Bit	Name	Access	Description	Default
15:7	Reserved	RW	Reserved	0
6:3	STW_DEV_TYP E	RW	Target two-wire serial slave device type	0
2:0	STW_ADDR	RW	Target two-wire serial slave device address	0

Table 269 • STW_REGADDR: STW Register Address (1E×8003)

Bit	Name	Access	Description	Default
15:0	STW_REG	RW	Intended register address to access within the two-wire serial slave device	0

Table 270 • STW_CFG1: STW Configuration 1 (1E×8004)

Bit	Name	Access	Description	Default
15:13	Reserved	RW	Reserved	0
12	STW_MSA_MODE	RW	MSA register map compliance type; this influences the STW_EXT_CMD selection. 0: XENPAK 1: XFP	0
11	STW_ADDR_MODE	RW	Selects the two-wire serial device addressing mode 0: 7-bit 1: Reserved	0
10:9	STW_SPEED_MODE	RW	Selects the two-wire serial bus speed 00: Standard (100 kHz) 01: Fast (400 kHz) 1x: Reserved	0
8:0	Reserved	RW	Reserved	0

Table 271 • NVR Memory Map (1E×8007–8106)

Bit	Name	Access	Description	Default
15:8	Reserved	RO	Reserved	0
7:0		RW	Consult the XENPAK or XFP specifications for a description of the NVR mapping.	0

Table 272 • DOM_RXALRM_CTRL: DOM Rx Alarm Control (1E×9000)

Bit	Name	Access	Description	Default
15:5	Reserved	RO	Reserved	0
4	FAULT_RX_PMA_ENA	RW	PMA receive local fault enable 0: Disable 1: Enable	1
3	FAULT_RX_PCS_ENA	RW	PCS receive local fault enable 0: Disable 1: Enable	1
2	VEND_SPEC	RO	Vendor Specific	0
1	FLAG_RX_ENA	RW	RX_FLAG enable 0: Disable 1: Enable	0

Table 272 • DOM_RXALRM_CTRL: DOM Rx Alarm Control (1E×9000) (continued)

Bit	Name	Access	Description	Default
0	FAULT_RX_PHYXS_EN A	RW	PHY XS receive local fault enable 0: Disable 1: Enable	1

Table 273 • DOM_TXALRM_CTRL: DOM Tx Alarm Control (1E×9001)

Bit	Name	Access	Description	Default
15:5	Reserved	RO	Reserved	0
4	FAULT_TX_PMA_ENA	RW	PMA transmit local fault enable 0: Disable 1: Enable	1
3	FAULT_TX_PCS_ENA	RW	PCS transmit local fault enable 0: Disable 1: Enable	1
2	VEND_SPEC	RO	Vendor specific	0
1	FLAG_TX_ENA	RW	TX_FLAG enable 0: Disable 1: Enable	0
0	FAULT_TX_PHYXS_EN A	RW	PHY XS transmit local fault enable 0: Disable 1: Enable	1

Table 274 • DOM_LASI_CTRL: DOM Link Alarm Status Interrupt Control (1E×9002)

Bit	Name	Access	Description	Default
15:3	Reserved	RO	Reserved	0
2	ALARM_RX_ENA	RW	Receive alarm enable 0: Disable 1: Enable	0
1	ALARM_TX_ENA	RW	Transmit alarm enable 0: Disable 1: Enable	0
0	ALARM_LS_ENA	RW	Link status alarm enable 0: Disable 1: Enable	0

Table 275 • DOM_RXALRM_STAT: DOM Rx Alarm Status (1E×9003)

Bit	Name	Access	Description	Default
15:5	Reserved	RO	Reserved	0
4	FAULT_RX_PMA_STAT	RO/LH	PMA receiver local fault 0: No fault asserted 1: Fault asserted See also 1×0008.10	0

Table 275 • DOM_RXALRM_STAT: DOM Rx Alarm Status (1E×9003) (continued)

Bit	Name	Access	Description	Default
3	FAULT_RX_PCS_STAT	RO/LH	PCS receive local fault 0: No fault asserted 1: Fault asserted See also 3×0008.10	0
2	Vendor Specific	RO	Vendor specific	0
1	FLAG_RX_STAT	RO/LH	Receive flag status 0: No fault asserted 1: Fault asserted	0
0	FAULT_RX_PHYXS_STAT	RO/LH	PHY XS receive local fault 0: No fault asserted 1: Fault asserted See also 4×0008.10	0

Table 276 • DOM_TXALRM_STAT: DOM Tx Alarm Status (1E×9004)

Bit	Name	Access	Description	Default
15:5	Reserved	RO	Reserved	0
4	FAULT_TX_PMA_STAT	RO/LH	PMA transmit local fault status 0: No fault asserted 1: Fault asserted See also 1×0008.11	0
3	FAULT_TX_PCS_STAT	RO/LH	PCS transmit local fault status 0: No fault asserted 1: Fault asserted See also 3×0008.11	0
2	Vendor Specific	RO	Vendor specific	0
1	FLAG_TX_STAT	RO/LH	Transmit flag fault status 0: No fault asserted 1: Fault asserted	0
0	FAULT_TX_PHYXS_STAT	RO/LH	PHY XS transmit local fault status 0: No fault asserted 1: Fault asserted See also 4×0008.11	0

Table 277 • DOM_LASI_STAT: DOM Link Alarm Status Interrupt Status (1E×9005)

Bit	Name	Access	Description	Default
15:3	Reserved	RO	Reserved	0
2	ALARM_RX_STAT	RO	Receive alarm status 0: No fault asserted 1: Fault asserted	0
1	ALARM_TX_STAT	RO	Transmit alarm status 0: No fault asserted 1: Fault asserted	0

Table 277 • DOM_LASI_STAT: DOM Link Alarm Status Interrupt Status (1E×9005) (continued)

Bit	Name	Access	Description	Default
0	ALARM_LS_STAT	RO/LH	Link status alarm status 0: No status change 1: Status change	0

Table 278 • DOM_TXFLAG_CTRL: DOM Tx Flag Control (1E×9006)

Bit	Name	Access	Description	Default
15:8	Reserved	RW	Reserved	0
7	TXFLAG_HI_TEMP_ENA	RW	High temperature alarm enable 0: Disable 1: Enable	0
6	TXFLAG_LO_TEMP_ENA	RW	Low temperature alarm enable 0: Disable 1: Enable	0
5:4	Reserved	RW	Reserved	0
3	TXFLAG_HI_LBIAS_ENA	RW	Laser bias current high alarm enable 0: Disable 1: Enable	0
2	TXFLAG_LO_LBIAS_ENA	RW	Laser bias current low alarm enable 0: Disable 1: Enable	0
1	TXFLAG_HI_TXPWR_EN A	RW	Laser output power high alarm enable 0: Disable 1: Enable	0
0	TXFLAG_LO_TXPWR_EN A	RW	Laser output power low alarm enable 0: Disable 1: Enable	0

Table 279 • DOM_RXFLAG_CTRL: DOM Rx Flag Control (1E×9007)

Bit	Name	Access	Description	Default
15:8	Reserved	RW	Reserved	0
7	RXFLAG_HI_RXPWR_EN A	RW	Receive optical power high alarm enable 0: Disable 1: Enable	0
6	RXFLAG_LO_RXPWR_EN A	RW	Receive optical power low alarm enable 0: Disable 1: Enable	0
5:0	Reserved	RW	Reserved	0

Table 280 • Factory Test Register (1E×A000-A027)

Bit	Name	Access	Description	Default
15:0	Reserved	RO	Factory test only; do not modify	0

Table 281 • Factory Test Register (1E×A048-A05F)

Bit	Name	Access	Description	Default
15:0	Reserved	RO	Factory test only; do not modify	0

Table 282 • Factory Test Register (1E×A060-A06D)

Bit	Name	Access	Description	Default
15:0	Reserved	RO	Factory test only; do not modify	0

Table 283 • Factory Test Register (1E×A06E)

Bit	Name	Access	Description	Default
15:0	Reserved	RO	Factory test only; do not modify	0

Table 284 • Factory Test Register (1E×A06F)

Bit	Name	Access	Description	Default
15:0	Reserved	RO	Factory test only; do not modify	0

Table 285 • DOM_TXALARM: DOM Tx Alarm Flags (1E×A070)

Bit	Name	Access	Description	Default
15:8	Reserved	RO	Reserved	0
7	ALARM_HI_XCVRTEMP_STAT	RO	Transceiver temperature high alarm status 0: No alarm asserted 1: Alarm asserted	0
6	ALARM_LO_XCVRTEMP_STAT	RO	Transceiver temperature low alarm status 0: No alarm asserted 1: Alarm asserted	0
5:4	Reserved	RO	Reserved	0
3	ALARM_HI_LBIAS_STAT	RO	Laser bias current high alarm status 0: No alarm asserted 1: Alarm asserted	0

Table 285 • DOM_TXALARM: DOM Tx Alarm Flags (1E×A070) (continued)

Bit	Name	Access	Description	Default
2	ALARM_LO_LBIAS_STAT	RO	Laser bias current low alarm status 0: No alarm asserted 1: Alarm asserted	0
1	ALARM_HI_TXPWR_STAT	RO	Laser output power high alarm status 0: No alarm asserted 1: Alarm asserted	0
0	ALARM_LO_TXPWR_STAT	RO	Laser output power low alarm status 0: No alarm asserted 1: Alarm asserted	0

Table 286 • DOM_RXALARM: DOM Rx Alarm Flags (1E×A071)

Bit	Name	Access	Description	Default
15:8	Reserved	RO	Reserved	0
7	ALARM_HI_RXPWR_STAT	RO	Receive optical power high alarm status 0: No alarm asserted 1: Alarm asserted	0
6	ALARM_LO_RXPWR_STAT	RO	Receive optical power low alarm status 0: No alarm asserted 1: Alarm asserted	0
5:0	Reserved	RO	Reserved	0

Table 287 • Factory Test Register (1E×A072-A073)

Bit	Name	Access	Description	Default
15:0	Reserved	RO	Factory test only; do not modify	0

Table 288 • DOM_TXWARN: DOM Tx Warning Flags (1E×A074)

Bit	Name	Access	Description	Default
15:8	Reserved	RO	Reserved	0
7	WARN_HI_XCVRTEMP_STAT	RO	Transceiver temperature high warning status 0: No warning asserted 1: Warning asserted	0
6	WARN_LO_XCVRTEMP_STAT	RO	Transceiver temperature low warning status 0: No warning asserted 1: Warning asserted	0
5:4	Reserved	RO	Reserved	0
3	WARN_HI_LBIAS_STAT	RO	Laser bias current high warning status 0: No warning asserted 1: Warning asserted	0

Table 288 • DOM_TXWARN: DOM Tx Warning Flags (1E×A074) (continued)

Bit	Name	Access	Description	Default
2	WARN_LO_LBIAS_STAT	RO	Laser bias current low warning status 0: No warning asserted 1: Warning asserted	0
1	WARN_HI_TXPWR_STAT	RO	Laser output power high warning status 0: No warning asserted 1: Warning asserted	0
0	WARN_LO_TXPWR_STAT	RO	Laser output power low warning status 0: No warning asserted 1: Warning asserted	0

Table 289 • DOM_RXWARN: DOM Rx Warning Flags (1E×A075)

Bit	Name	Access	Description	Default
15:8	Reserved	RO	Reserved	0
7	WARN_HI_RXPWR_STAT	RO	Receive optical power high warning status 0: No warning asserted 1: Warning asserted	0
6	WARN_LO_RXPWR_STAT	RO	Receive optical power low warning status 0: No warning asserted 1: Warning asserted	0
5:0	Reserved	RO	Reserved	0

Table 290 • Factory Test Register (1E×A076-A077)

Bit	Name	Access	Description	Default
15:0	Reserved	RO	Factory test only; do not modify	0

Table 291 • Factory Test Register (1E×A0C0-A0FF)

Bit	Name	Access	Description	Default
15:0	Reserved	RO	Factory test only; do not modify	0

Table 292 • Factory Test Register (1E×A100)

Bit	Name	Access	Description	Default
15:0	Reserved	RW	Reserved	0

Table 293 • Factory Test Register (1E×A101-A106)

Bit	Name	Access	Description	Default
7:0	Reserved	RW	Factory test only; do not modify	0

5 Electrical Specifications

This section provides the DC characteristics, AC characteristics, recommended operating conditions, and stress ratings for the VSC8486-11 device.

5.1 DC Characteristics

This section contains the DC specifications for the VSC8486-11 device.

5.1.1 LVTTTL Inputs and Outputs

The following table shows the LVTTTL I/O specifications for the VSC8486-11 device.

Table 294 • LVTTTL I/O Specifications

Parameter	Symbol	Minimum	Maximum	Unit	Condition
Output high voltage	V_{OH}	2.4	V_{DDTTL}	V	$V_{DDTTL} = 3.3\text{ V}$ and $I_{OH} = -4\text{ mA}$
		1.8	V_{DDTTL}		$V_{DDTTL} = 2.5\text{ V}$ and $I_{OH} = -4\text{ mA}$
		1.4	V_{DDTTL}		$V_{DDTTL} = 1.8\text{ V}$ and $I_{OH} = -2\text{ mA}$
		1.1	V_{DDTTL}		$V_{DDTTL} = 1.5\text{ V}$ and $I_{OH} = -2\text{ mA}$
		0.88	V_{DDTTL}		$V_{DDTTL} = 1.2\text{ V}$ and $I_{OH} = -1\text{ mA}$
Output high voltage, open drain	V_{OH_OD}	3.2	V_{DDTTL}	V	$V_{DDTTL} = 3.3\text{ V}$ and $I_{OH} = 100\text{ }\mu\text{A}$
		2.4	V_{DDTTL}		$V_{DDTTL} = 2.5\text{ V}$ and $I_{OH} = 100\text{ }\mu\text{A}$
		1.7	V_{DDTTL}		$V_{DDTTL} = 1.8\text{ V}$ and $I_{OH} = 100\text{ }\mu\text{A}$
		1.4	V_{DDTTL}		$V_{DDTTL} = 1.5\text{ V}$ and $I_{OH} = 100\text{ }\mu\text{A}$
		0.9	V_{DDTTL}		$V_{DDTTL} = 1.2\text{ V}$ and $I_{OH} = 100\text{ }\mu\text{A}$
Output low voltage (LVTTTL, open drain)	V_{OL}	0.0	0.5	V	$V_{DDTTL} = 3.3\text{ V}$ and $I_{OL} = 4\text{ mA}$
		0.0	0.5		$V_{DDTTL} = 2.5\text{ V}$ and $I_{OL} = 4\text{ mA}$
		0.0	0.4		$V_{DDTTL} = 1.8\text{ V}$ and $I_{OL} = 2\text{ mA}$
		0.0	0.2		$V_{DDTTL} = 1.5\text{ V}$ and $I_{OL} = 2\text{ mA}$
		0.0	0.2		$V_{DDTTL} = 1.2\text{ V}$ and $I_{OL} = 1\text{ mA}$
Input high voltage ¹	V_{IH}	2.0	V_{DDTTL}	V	$V_{DDTTL} = 3.3\text{ V}$
		1.7	V_{DDTTL}		$V_{DDTTL} = 2.5\text{ V}$
		1.2	V_{DDTTL}		$V_{DDTTL} = 1.8\text{ V}$
		1.05	V_{DDTTL}		$V_{DDTTL} = 1.5\text{ V}$
		0.85	V_{DDTTL}		$V_{DDTTL} = 1.2\text{ V}$
Input low voltage	V_{IL}	0.0	0.8	V	$V_{DDTTL} = 3.3\text{ V}$
		0.0	0.8		$V_{DDTTL} = 2.5\text{ V}$
		0.0	0.6		$V_{DDTTL} = 1.8\text{ V}$
		0.0	0.45		$V_{DDTTL} = 1.5\text{ V}$
		0.0	0.4		$V_{DDTTL} = 1.2\text{ V}$
Input high current	I_{IH}		500	μA	$V_{IH} = V_{DDTTL}$
Input low current	I_{IL}	-50		μA	$V_{IL} = 0\text{ V}$

1. Input is 3.3 V tolerant.

5.1.2 Reference Clock

REFCLKP/N has an exposed center tap (REFTERM), whereas WREFCLKP/N and VREFCLKP/N do not. For more information about reference clock inputs, see [Reference Clock Inputs](#), page 18. The following table shows the reference clock input specifications for the VSC8486-11 device.

Table 295 • Reference Clock Input Specifications

Parameter	Symbol	Minimum	Typical	Maximum	Unit	Condition
Input voltage	ΔV_{REFCLK}	150		2000	mV	Measured peak-to-peak both sides driven
		300		2000	mV	Measured peak-to-peak single-ended driven
Input common-mode voltage	V_{CM}	700		950	mV	
REFTERM voltage	V_{REFTERM}		$0.67 \times V_{\text{DD12TX}}$		V	$V_{\text{DD12TX}} = 1.2 \text{ V}$

5.1.3 MDIO Interface

The following table shows the MDIO interface specifications for the VSC8486-11 device.

Table 296 • MDIO Interface Characteristics

Parameter	Symbol	Minimum	Maximum	Unit	Condition
Input high voltage ¹	V_{IH}	0.84	V_{DDTTL}	V	
Input low voltage	V_{IL}	0	0.36	V	
Output high voltage ²	V_{OH}	1.0	V_{DDTTL}	V	$I_{\text{OH}} = -100 \mu\text{A}$
Output low voltage	V_{OL}	0	0.2	V	$I_{\text{OL}} = 100 \mu\text{A}$
Output high current	I_{OH}		-4	mA	$V_{\text{I}} = 1.5 \text{ V}$
Output low current	I_{OL}	4.0		mA	$V_{\text{I}} = 0.2 \text{ V}$
Input capacitance	C_{IN}		10	pF	
Bus loading	C_{L}		470	pF	

1. Input is 3.3 V tolerant.
2. Output is open drain and pulled up to 1.5 V through a 4.7 k Ω resistor.

5.2 AC Characteristics

This section contains the AC specifications for the VSC8486-11 device.

5.2.1 10-Gigabit Inputs and Outputs

The following table shows the serial data input specifications for the VSC8486-11 device.

Table 297 • 10-Gigabit Serial Data Input Specifications

Parameter	Symbol	Minimum	Typical	Maximum	Unit	Condition
Data differential input swing	$\Delta V_{\text{SWING_DIFF}}$	55		1050	mV	Measured peak-to-peak both sides driven with no offset applied
Data single-ended input swing	$\Delta V_{\text{SWING_SE}}$	110		1050	mV	Measured peak-to-peak single-ended driven with no offset applied
Differential input return loss ¹	SDD11		-12		dB	0.1 GHz to 2 GHz
			See ²		dB	2 GHz to 11.1 GHz
Reflected differential to common-mode conversion ¹	SCD11		-10		dB	0.1 GHz to 11.1 GHz
Termination resistor current	I_{TERM}			25	mA	RXIN to RXINCM
RXDATA input common mode voltage	V_{RXINCM}		$0.68 \times V_{\text{DD12RX}}$		V	

- Limited sample size tested under nominal conditions.
- Return loss is $\text{SDD11}(\text{dB}) < -6.68 + 12.1 \times \log_{10}(f/5.5 \text{ GHz})$, with f in GHz.

Figure 55 • 10-Gigabit Data Input Compliance Mask

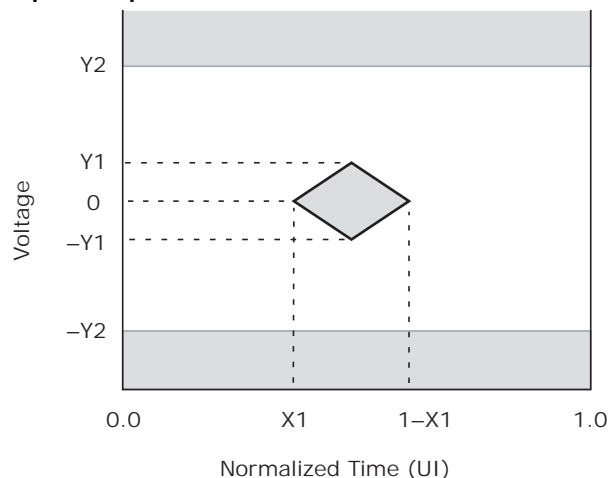
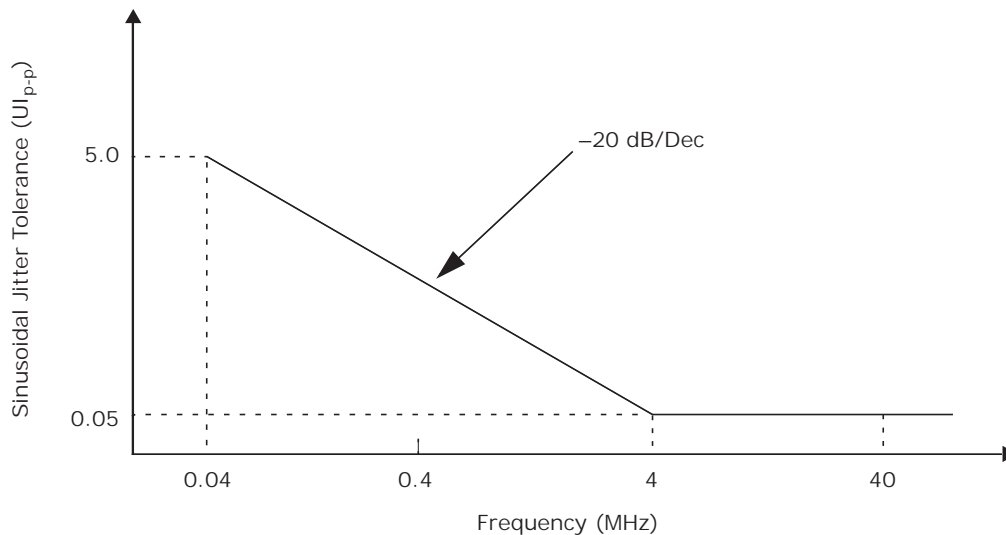

Figure 56 • Datacom Sinusoidal Jitter Tolerance

The following table shows the CRU input specifications for the VSC8486-11 device.

Table 298 • 10-Gigabit Serial Data Input Specifications for CRU

Parameter	Symbol	Minimum	Maximum	Unit	Condition
Difference between REFCLK frequency (with appropriate multiplier) and 10-gigabit input data frequency	Δf_{REFCLK}	-100	100	ppm	
Total jitter tolerance	TOL_{JIT_P-P}		0.70	UI	Calibrated and measured at point C", as specified in SFF-8431 revision 4.1 using the following EQ and CRU BW settings: 1×8002.14:11 = 1110 1×E604.15 = 1 1×8000.15:14 = 00 Board channel loss is 3 dB.
99% jitter	$99\%_{JIT_P-P}$		0.42	UI	Calibrated and measured at point C", as specified in SFF-8431 revision 4.1 using the following EQ, gain, and CRU BW settings: 1×8002.14:11 = 1110 1×E604.15 = 1 1×8000.15:14 = 00 Board channel loss is 3 dB.

Table 298 • 10-Gigabit Serial Data Input Specifications for CRU (continued)

Parameter	Symbol	Minimum	Maximum	Unit	Condition
Pulse width shrinkage jitter	DDPWS _{JIT_p-p}		0.3	UI	Calibrated and measured at point C", as specified in SFF-8431 revision 4.1 using the following EQ, gain, and CRU BW settings: 1×8002.14:11 = 1110 1×E604.15 = 1 1×8000.15:14 = 00 Board channel loss is 3 dB.
Sinusoidal jitter, Datacom	S _{J_DAT}		See Figure 56, page 182		SFF-8431 specification revision 4.1 Datacom mask.
Eye mask (X1)	X1		0.35	UI	Calibrated and measured at point C", as specified in SFF-8431 revision 4.1 using the following EQ, gain, and CRU BW settings: 1×8002.14:11 = 1110 1×E604.15 = 1 1×8000.15:14 = 00 Board channel loss is 3 dB. See Figure 55, page 181.
Eye mask (Y1)	Y1	150		mV	Calibrated and measured at point C", as specified in SFF-8431 revision 4.1 using the following EQ, gain, and CRU BW settings: 1×8002.14:11 = 1110 1×E604.15 = 1 1×8000.15:14 = 00 Board channel loss is 3 dB. See Figure 55, page 181.
Eye mask (Y2)	Y2		425	mV	Calibrated and measured at point C", as specified in SFF-8431 revision 4.1 using the following EQ, gain, and CRU BW settings: 1×8002.14:11 = 1110 1×E604.15 = 1 1×8000.15:14 = 00 Board channel loss is 3 dB. See Figure 55, page 181.

The following table shows the serial data output specifications for the VSC8486-11 device.

Table 299 • 10-Gigabit Serial Data Output Specifications

Parameter	Symbol	Minimum	Typical	Maximum	Unit	Condition
Common-mode output voltage TXDOUTP/N ¹	V _{CM}		0.9		V	
Common-mode return loss ¹	SCC22		See ²		dB	0.01 GHz to 2.5 GHz.
			-3		dB	2.5 GHz to 11.1 GHz.
Differential output return loss ¹	SDD22		-12		dB	0.01 GHz to 2 GHz.
			See ³		dB	2 GHz to 11.1 GHz.

- Limited sample size tested under nominal conditions.
- Return loss is $SCC22(dB) < -7 + 1.6 \times f$, with f in GHz.
- Return loss is $SDD22(dB) < -6.68 + 12.1 \times \log_{10}(f/5.5 \text{ GHz})$, with f in GHz.

The following table shows the CMU output specifications in WAN mode for the VSC8486-11 device.

Table 300 • 10-Gigabit Serial Data Input/Output Specifications for CMU, WAN Mode

Parameter	Symbol	Minimum	Typical	Unit	Condition
RXDINP/N jitter tolerance	J _{TOL}	1.5× SONET jitter mask			Measured peak-to-peak using the following settings: 1×8002.12:11 = 0×2 1×8002.14:13 = 0×3 1×E604.15 = 0×1 1×8000.15:14 = 0×0 Compliant with 1.5× SONET jitter mask. GR1377-CORE. ¹
TXDOUTP/N jitter	JG _{OUT}		0.06	UI	Measured peak-to-peak. WREFCLK = 622.08 MHz low jitter. Reference clock required. ²

- Measured 1 dB above minimum RXIN input sensitivity.
- For optimal J_G and rise and fall time performance, adjustments might be required to the transmit pre-emphasis or transmit slew rate or both in registers 1×E601 and 1×E603.

The following table shows the CMU output specifications in LAN/SAN mode for the VSC8486-11 device.

Table 301 • 10-Gigabit Serial Data Output Specifications for CMU, LAN/SAN Mode

Parameter	Symbol	Minimum	Maximum	Unit	Condition
TXDOUTP/N total jitter	TJDOUT		0.28	UI	Calibrated and measured at point B, as specified in SFF-8431 revision 4.1 using the following PE and DE/swing settings: 1×E601.7:0 = 0×8E 1×E603 = 0×110F Board channel loss is 3 dB.

Table 301 • 10-Gigabit Serial Data Output Specifications for CMU, LAN/SAN Mode (continued)

Parameter	Symbol	Minimum	Maximum	Unit	Condition
Data-dependant jitter	DDJ		0.1	UI	Calibrated and measured at point B, as specified in SFF-8431 revision 4.1 using the following PE and DE/swing settings: 1×E601.7:0 = 0×8E 1×E603 = 0×110F Board channel loss is 3 dB.
Data-dependant pulse width shrinkage	DDPWS _{p-p}		0.055	UI	Calibrated and measured at point B, as specified in SFF-8431 revision 4.1 using the following PE and DE/swing settings: 1×E601.7:0 = 0×8E 1×E603 = 0×110F Board channel loss is 3 dB.
Uncorrelated jitter	UJ _{rms}		0.023	UI	Calibrated and measured at point B, as specified in SFF-8431 revision 4.1 using the following PE and DE/swing settings: 1×E601.7:0 = 0×8E 1×E603 = 0×110F Board channel loss is 3 dB.
CLK64P/N jitter generation	JG _{C64}		0.11	UI	Measured peak-to-peak. CLK64A and CLK64B in CMU/64, CMU/66, and CRU/64 modes.
CLK64P/N output swing	ΔV	320	800	mV	CMU/64, CMU/66, and CRU/64 modes.
Eye mask (X1)	X1		0.12	UI	Calibrated and measured at point B, as specified in SFF-8431 revision 4.1 using the following PE and DE/swing settings: 1×E601.7:0 = 0×8E 1×E603 = 0×110F Board channel loss is 3 dB. See Figure 55 , page 181.
Eye mask (X2)	X2		0.33	UI	Calibrated and measured at point B, as specified in SFF-8431 revision 4.1 using the following PE and DE/swing settings: 1×E601.7:0 = 0×8E 1×E603 = 0×110F Board channel loss is 3 dB. See Figure 55 , page 181.

Table 301 • 10-Gigabit Serial Data Output Specifications for CMU, LAN/SAN Mode (continued)

Parameter	Symbol	Minimum	Maximum	Unit	Condition
Eye mask (Y1)	Y1	95		mV	Calibrated and measured at point B, as specified in SFF-8431 revision 4.1 using the following PE and DE/swing settings: 1×E601.7:0 = 0×8E 1×E603 = 0×110F Board channel loss is 3 dB. See Figure 55, page 181.
Eye mask (Y2)	Y2		350	mV	Calibrated and measured at point B, as specified in SFF-8431 revision 4.1 using the following PE and DE/swing settings: 1×E601.7:0 = 0×8E 1×E603 = 0×110F Board channel loss is 3 dB. See Figure 55, page 181.

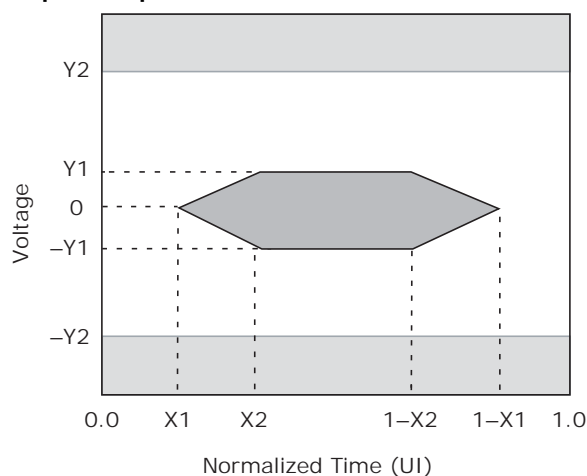
Figure 57 • 10-Gigabit Data Output Compliance Mask

5.2.2 XAUI Inputs and Outputs

The following table shows the XAUI input specifications for the VSC8486-11 device.

Table 302 • XAUI Input Specifications

Parameter	Symbol	Minimum	Typical	Maximum	Unit	Condition
Input baud rate	f	3.125 – 100 ppm		3.1875 + 100 ppm	Gbps	
Unit interval	UI		320		ps	3.125 Gbps – 100 ppm to 3.1875 Gbps + 100 ppm
Differential input amplitude	V_{IN_DIFF}	75		1600	mV	AC-coupled, measured peak-to-peak each side (both sides driven)

Table 302 • XAUI Input Specifications (continued)

Parameter	Symbol	Minimum	Typical	Maximum	Unit	Condition
Common-mode input voltage	V_{IN_CM}	0.75		$V_{DDA12} - 0.05$	V	Midpoints between high and low voltages, measured at DC
Differential return loss ¹	RL_{DIFF}		-10		dB	100 Ω differential reference impedance
Common-mode return loss ¹	RL_{CM}		-6		dB	100 MHz to 2.5 GHz, 25 Ω reference impedance
Differential skew	SK_{DIFF}			75	ps	Between true and complement inputs
Jitter tolerance, total	TOL_{TJ}	0.65			UI	Measured peak-to-peak, see IEEE 802.3ae-2002, clause 47.3.4
Jitter tolerance, deterministic	TOL_{DJ}	0.37			UI	Measured peak-to-peak, see IEEE 802.3ae-2002, clause 47.3.4
Jitter tolerance, deterministic plus random jitter	TOL_{DJ+RJ}	0.55			UI	Measured peak-to-peak, see IEEE 802.3ae-2002, clause 47.3.4

1. Limited sample size tested under nominal conditions.

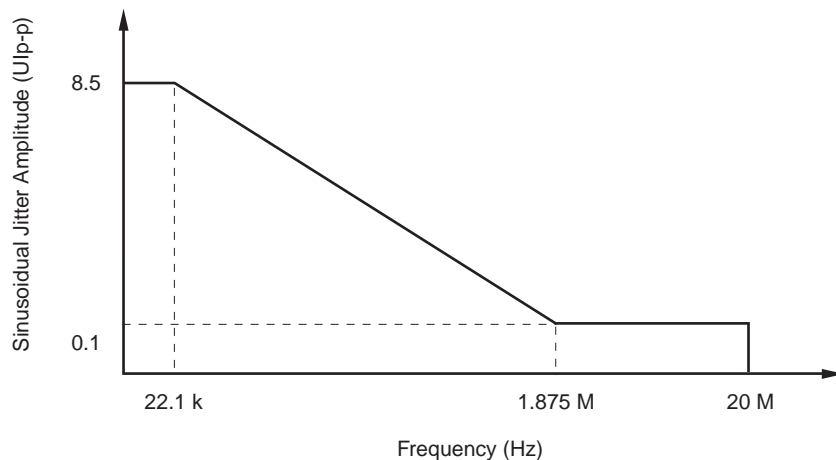
Figure 58 • XAUI Receiver Input Sinusoidal Jitter Tolerance

The following table shows the XAUI output specifications for the VSC8486-11 device.

Table 303 • XAUI Output Specifications

Parameter	Symbol	Minimum	Typical	Maximum	Unit	Condition
Output baud rate	f	3.125 – 100 ppm		3.1875 + 100 ppm	Gbps	
Unit interval	UI		320		ps	3.125 Gbps – 100 ppm to 3.1875 Gbps + 100 ppm.

Table 303 • XAUI Output Specifications (continued)

Parameter	Symbol	Minimum	Typical	Maximum	Unit	Condition
Differential output voltage	XV_{OUT_DIFF}	100		800	mV	Single-ended, AC-coupled. Measured peak-to-peak at far end, both sides driven with no offset applied. HISWNG = 0.
Differential output return loss ⁽¹⁾	RLO_{DIFF}		-10		dB	100 MHz to 781.25 MHz, reducing 20 dB per decade up to 3.5 GHz. Includes on-chip circuitry, packaging, and off-chip components. 100 Ω test source.
Common-mode output return loss ⁽¹⁾	RLO_{CM}		-6		dB	100 MHz to 2.5 GHz over valid output levels. Includes on-chip circuitry, packaging, and off-chip components. 25 Ω test source.
Rise time and fall time	t_R, t_F	60		130	ps	20% for rise time. 80% for fall time.
Total jitter	T_J			0.55	UI	Measured peak-to-peak at far end template.
Deterministic jitter	DJ			0.37	UI	Measured peak-to-peak at far end template.
Eye mask (X1)	X1			0.275	UI	Measured at far end template. See Figure 59, page 189.
Eye mask (X2)	X2			0.40	UI	Measured at far end template. See Figure 59, page 189.
Eye mask (A1)	A1	100			mV	HISWNG = 0. Measured at far end template. See Figure 59, page 189.
Eye mask (A2)	A2			800	mV	HISWNG = 0. Measured at far end template. See Figure 59, page 189.

Figure 59 • XAUI Output Compliance Mask

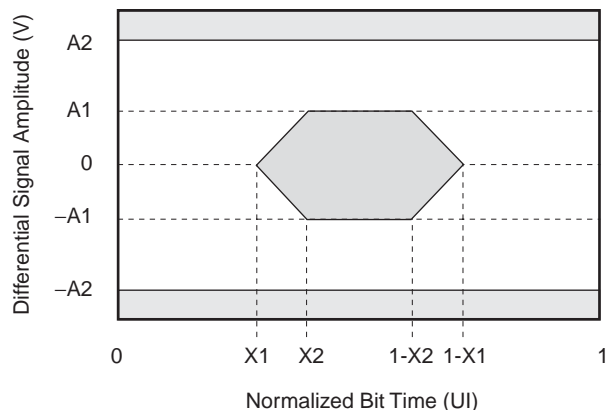

5.2.3 Timing and Reference Clock

The following tables show the timing and reference clock specifications for the VSC8486-11 device.

Table 304 • Reset Timing

Parameter	Symbol	Minimum	Unit	Condition
Minimum reset pulse width	T_{RESET}	0.1	μs	All power supplies are stable

Table 305 • Reference Clock Specifications

Parameter	Symbol	Minimum	Maximum	Unit	Condition
REFCK frequency	f_{REFCLK}	153.00 MHz – 100 ppm	159.37 MHz + 100 ppm	MHz	Pins: REFSEL[1:0] = 00
REFCKP/N duty cycle	DC_{REFCK}	40	60	%	

Figure 60 • Parametric Measurement Setup

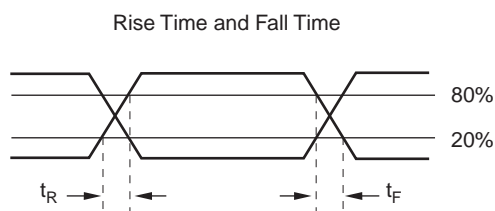

Figure 61 • Timing with MDIO Sourced by STA

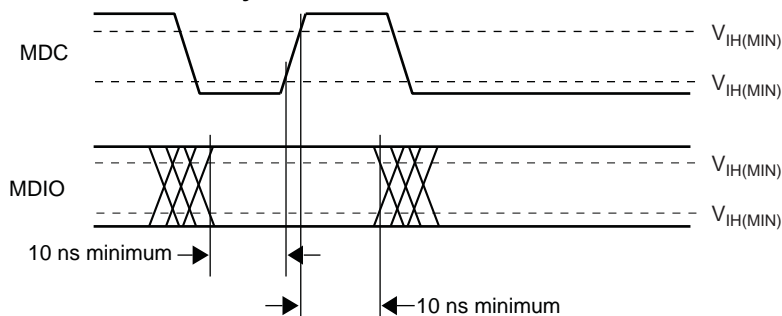
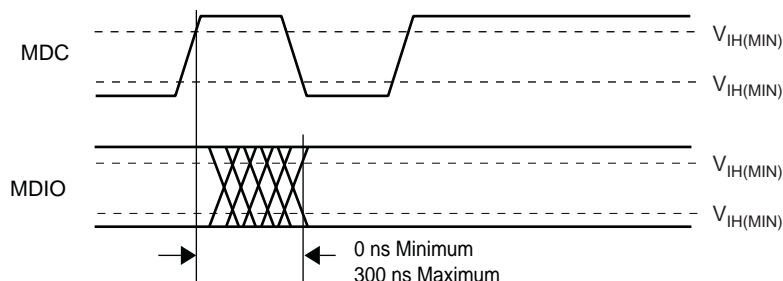

Figure 62 • Timing with MDIO Sourced by MMD

5.3 Operating Conditions

The following table shows the recommended operating conditions for the VSC8486-11 device.

To ensure that the control pins remain set to the desired configured state when the VSC8486-11 device is powered up, it is required to perform a reset through the reset pin after power-up and after the control pins are steady for 1 ms.

Table 306 • Recommended Operating Conditions

Parameter	Symbol	Minimum	Typical	Maximum	Unit	Condition
1.2 V power supply voltage	V_{DD12RX} V_{DD12TX} V_{DDA12} V_{DD12X} $V_{DD12PCS}$	1.14	1.2	1.26	V	
1.2 V power supply current	I_{DD12}		625		mA	XAUI to 10 gigabit data in LAN mode
Power consumption at 1.2 V power supply	P_{DD12}		753	998	mW	XAUI to XFI in LAN
			839	1130	mW	XAUI to XFI in WAN
TTL I/O power supply voltage	V_{DDTTL}	3.14	3.3	3.47	V	$V_{DDTTL} = 3.3$ V
		2.38	2.5	2.63		$V_{DDTTL} = 2.5$ V
		1.71	1.8	1.89		$V_{DDTTL} = 1.8$ V
		1.43	1.5	1.58		$V_{DDTTL} = 1.5$ V
		1.14	1.2	1.26		$V_{DDTTL} = 1.2$ V
TTL I/O power supply current	I_{DDTTL}		3		mA	$V_{DDTTL} = 3.3$ V, 2.5 V, 1.8 V, 1.5 V
Operating temperature ¹	T	-40		85	°C	

1. Minimum specification is ambient temperature, and the maximum is case temperature.

5.4 Stress Ratings

This section contains the stress ratings for the VSC8486-11 device.

Note: Stresses listed in the following table may be applied to devices one at a time without causing permanent damage. Functionality at or exceeding the values listed is not implied. Exposure to these values for extended periods may affect device reliability

Table 307 • Stress Ratings

Parameter	Symbol	Minimum	Maximum	Unit
3.3 V power supply voltage, potential to ground	V_{DDTTL}	-0.5	3.8	V

Table 307 • Stress Ratings (continued)

Parameter	Symbol	Minimum	Maximum	Unit
2.5 V power supply voltage, potential to ground	V_{DDTTL}	-0.5	2.9	V
1.8 V power supply voltage, potential to ground	V_{DDTTL}	-0.5	2.1	V
1.2 V power supply voltage, potential to ground	V_{DD12}	-0.5	1.32	V
DC input voltage	V_I	-0.3	V_{DDTTL} or $V_{DD12} + 0.3$	V
Output current (LVTTL)	$I_{O_V_{DDTTL}}$	-16	16	mA
Absolute XAUI output voltage	V_{XAUI_ABS}	-0.4	2.3	V
Storage temperature	T_S	-65	150	°C
Electrostatic discharge voltage, charged device model	V_{ESD_CDM}	-200	200	V
Electrostatic discharge voltage, human body model	V_{ESD_HBM}	-1000	1000	V

Note: This device can be damaged by electrostatic discharge (ESD) voltage. Microsemi recommends that all integrated circuits be handled with appropriate precautions. Failure to observe proper handling and installation procedures may adversely affect reliability of the device.

6 Pin Descriptions

The VSC8486-11 device has 144 pins, which are described in this section.

The pin information is also provided as an attached Microsoft Excel file, so that you can copy it electronically. In Adobe Reader, double-click the attachment icon.

6.1 Pin Diagram

The following illustration shows the pin diagram for the VSC8486-11 device, as seen from the top view.

Figure 63 • Pin Diagram

	1	2	3	4	5	6	7	8	9	10	11	12
A	WREFCKP	GND	REFCKN	REFCKP	GND	XTX3N	XTX3P	GND	XRX3N	XRX3P	GND	XTX2N
B	WREFCKN	GND	GND	REFTERM	GND	Reserved	Reserved	GND	GND	GND	GND	XTX2P
C	GND	GND	VREFCKP	GND	RXALARM	WIS_INTA	FORCEAIS	LOPC	LPP_10B	RCLKOUT	LP_16B	GND
D	TXDOUTP	GND	VREFCKN	TXALARM	Reserved	REFSELO	LASI	RFPOUT	RDAOUT	TDAIN	XAUIFILT	XRX2N
E	TXDOUTN	GND	GND	VDD12TX	SPLITLOOPN	VDD12PCS	GND	VDDA12	VDD12X	TCLKOUT	GND	XRX2P
F	GND	GND	CLK64BP	VDD12TX	VDDTTL	VDD12PCS	GND	VDDA12	VDD12X	Reserved	GND	GND
G	CMUFILT	GND	CLK64BN	GND	GND	VDD12PCS	GND	VDDA12	VDD12X	GND	TFPOUT	GND
H	GND	GND	GND	VDD12RX	GND	VDD12PCS	GND	VDDA12	VDD12X	MSTCODE1	MSTCODE0	XTX1N
J	RXINP	RXINCM	CLK64AP	VDD12RX	VDDTTL	VDD12PCS	MDC	PRTAD3	PRTAD2	PRTAD1	GND	XTX1P
K	RXINN	GND	CLK64AN	RESETN	GND	WIS_INTB	STWSCL	MDIO	PRTAD0	EPCS	GND	GND
L	GND	CRUFILT	GND	TMS	TCK	GND	PRTAD4	STWSDA	GND	GND	AUTONEG	XRX1N
M	GND	GND	TDO	TDI	TRSTB	XRXOP	XRXON	GND	XTXOP	XTXON	Reserved	XRX1P

6.2 Pins by Function

This section contains the functional pin descriptions for the VSC8486-11 device.

6.2.1 XFI 10-Gigabit Data Bus Interface

The following table lists the pins associated with the XFI interface.

Table 308 • XFI 10-Gigabit Data Bus Pins

Name	Number	I/O	Type	Description
RXINCM	J2		Analog	Rx 10-gigabit serial data input resistor termination center tap
RXINN	K1	I	CML	Rx 10-gigabit serial data input, complement
RXINP	J1	I	CML	Rx 10-gigabit serial data input, true
TXDOUTN	E1	O	CML	Tx 10-gigabit serial data output, complement
TXDOUTP	D1	O	CML	Tx 10-gigabit serial data output, true

6.2.2 XAUI 10-Gigabit Data Bus Interface

The following table lists the pins associated with the XAUI interface.

Table 309 • XAUI 10-Gigabit Data Bus Pins

Name	Number	I/O	Type	Description
XAUIFILT	D11		Analog	XAUI CMU filter capacitor (1 μ F) from this pin to ground.
XR0N	M7	I	CML	XAUI channel 0 serial data input, complement. DL0<N> as specified in IEEE 802.3ae.
XR0P	M6	I	CML	XAUI channel 0 serial data input, true. DL0<P> as specified in IEEE 802.3ae.
XR1N	L12	I	CML	XAUI channel 1 serial data input, complement. DL1<N> as specified in IEEE 802.3ae.
XR1P	M12	I	CML	XAUI channel 1 serial data input, true. DL1<P> as specified in IEEE 802.3ae.
XR2N	D12	I	CML	XAUI channel 2 serial data input, complement. DL2<N> as specified in IEEE 802.3ae.
XR2P	E12	I	CML	XAUI channel 2 serial data input, true. DL2<P> as specified in IEEE 802.3ae.
XR3N	A9	I	CML	XAUI channel 3 serial data input, complement. DL3<N> as specified in IEEE 802.3ae.
XR3P	A10	I	CML	XAUI channel 3 serial data input, true. DL3<P> as specified in IEEE 802.3ae.
XT0N	M10	O	CML	XAUI channel 0 serial data output, complement. SL0<N> as specified in IEEE 803.3ae.
XT0P	M9	O	CML	XAUI channel 0 serial data output, true. SL0<P> as specified in IEEE 803.3ae.
XT1N	H12	O	CML	XAUI channel 1 serial data output, complement. SL1<N> as specified in IEEE 802.3ae.
XT1P	J12	O	CML	XAUI channel 1 serial data output, true. SL1<P> as specified in IEEE 802.3ae.
XT2N	A12	O	CML	XAUI channel 2 serial data output, complement. SL2<N> as specified in IEEE 802.3ae.
XT2P	B12	O	CML	XAUI channel 2 serial data output, true. SL2<P> as specified in IEEE 803.3ae.

Table 309 • XAUI 10-Gigabit Data Bus Pins (continued)

Name	Number	I/O	Type	Description
XTX3N	A6	O	CML	XAUI channel 3 serial data output, complement. SL3<N> as specified in IEEE 802.3ae.
XTX3P	A7	O	CML	XAUI channel 3 serial data output, true. SL3<P> as specified in IEEE 802.3ae.

6.2.3 Serial Bus Interface

The following table lists the pins associated with the serial bus interface.

Table 310 • Serial Bus Interface Pins

Name	Number	I/O	Type	Description
MDC	J7	I	LVTTTL	Management data clock. Schmitt trigger.
MDIO	K8	I/O	LVTTTL (open drain)	Management data bus bidirectional I/O. Requires external pull-up resistor (nominally 4.7 kΩ).
MSTCODE0	H11	I	LVTTTL	Two-wire serial interface master code, bit 0. Can also be used as general purpose input.
MSTCODE1	H10	I	LVTTTL	Two-wire serial interface master code, bit 1 or alternate XFP alarm input, internally pulled low. Can also be used as general purpose input.
RCLKOUT	C10	O	LVTTTL	WIS overhead receive serial data clock.
RDAOUT	D9	O	LVTTTL	WIS overhead port receive serial data.
RFPOUT	D8	O	LVTTTL	WIS overhead port receive frame pulse.
STWSCL	K7	I	LVTTTL	Two-wire serial interface clock. Requires external pull-up resistor nominally 4.7 kΩ.
STWSDA	L8	I/O	LVTTTL	Serial input/output data for the two-wire serial interface. Requires external pull-up resistor, nominally 4.7 kΩ.
TCLKOUT	E10	O	LVTTTL	WIS overhead port transmit serial data clock.
TDAIN	D10	I	LVTTTL	WIS overhead port transmit serial data.
TFPOUT	G11	O	LVTTTL	WIS overhead port transmit frame pulse.

6.2.4 Input and Output Reference Clocks

The following table lists the pins associated with reference clocks.

Table 311 • Input and Output Reference Clock Pins

Name	Number	I/O	Type	Description
CLK64AN	K3	O	CML	Selectable clock, complement. CMU divided by 64, or CMU divided by 66, or CRU divided by 64, or REFCK. Default is CMU divided by 64. Normally used for XFP reference clock.
CLK64AP	J3	O	CML	Selectable clock, true. CMU divided by 64, or CMU divided by 66, or CRU divided by 64, or REFCK. Default is CMU divided by 64. Normally used for XFP reference clock.
CLK64BN	G3	O	CML	Selectable clock, complement. CMU divided by 64, or CMU divided by 66, or CRU divided by 64, or TEST_CLK. Default is CRU divided by 64 when enabled.

Table 311 • Input and Output Reference Clock Pins (continued)

Name	Number	I/O	Type	Description
CLK64BP	F3	O	CML	Selectable clock, true. CMU divided by 64, or CMU divided by 66, or CRU divided by 64, or TEST_CLK. Default is CRU divided by 64 when enabled.
REFCKN	A3	I	LVPECL	Reference clock input, complement. Terminated 50 Ω to REFTERM.
REFCKP	A4	I	LVPECL	Reference clock input, true. Terminated 50 Ω to REFTERM.
REFSEL0	D6	I	LVTTTL	WAN mode WREFCLK frequency select. 0: 622.08 MHz (default, internally pulled low). 1: 155.52 MHz.
REFTERM	B4	I	LVPECL	Reference clock input termination center tap.
VREFCKN	D3	I	LVPECL	WAN VCO reference clock, complement. The 10-gigabit CMU reference clock for WANMODE. 622.08 MHz VCISO input used in conjunction with external jitter attenuation PLL.
VREFCKP	C3	I	LVPECL	WAN VCO reference clock, true. The 10-gigabit CMU reference clock for WANMODE. 622.08 MHz VCISO input used in conjunction with external jitter attenuation PLL.
WREFCKN	B1	I	LVPECL	WAN reference clock, complement. Can be 155.52 MHz or 622.08 MHz. 622.08 MHz must be used for optimum jitter generation performance.
WREFCKP	A1	I	LVPECL	WAN Reference clock, true. Can be 155.52 MHz or 622.08 MHz. 622.08 MHz must be used for optimum jitter generation performance.

6.2.5 Status and Control

The following table lists the pins that issue status or enable various modes.

Table 312 • Status and Control Pins

Name	Number	I/O	Type	Description
AUTONEG	L11	I	LVTTTL	Auto-negotiate enable. Adjusts Tx encoder to match Rx input data. 0: Device resets to state set by EPCS pin. 1: Device will auto-negotiate enhanced or standard PCS. Internally pulled low.
EPCS	K10	I	LVTTTL	Extended-PCS enable. Sets start-up transmit encoder to E-PCS. 0: Device resets to IEEE standard PCS encoding 64/66B. 1: Device resets to EPCS encoding OIF-CEI "Firecode." Internally pulled low.
FORCEAIS	C7	I	LVTTTL	When asserted, forces the receive WIS into an AIS-L state.
LASI	D7	O	LVTTTL (open drain)	Link alarm status interrupt. Logical OR for RXALARM, TXALARM and LSALARM and as enabled by register 1E×9002. Open-drain output requires external pull-up resistor.

Table 312 • Status and Control Pins (continued)

Name	Number	I/O	Type	Description
LOPC	C8	I	LVTTTL	Loss of optical carrier normally connected to XFP RX_LOS output.
LP_16B	C11	I	LVTTTL	Reserved for factory test only. Internally pulled low by default.
LPP_10B	C9	I	LVTTTL	Reserved for factory test only. Internally pulled low by default.
PRTAD0	K9	I	LVTTTL	Port address bit 0 (LOW = 0). Internally pulled down.
PRTAD1	J10	I	LVTTTL	Port address bit 1 (LOW = 0). Internally pulled down.
PRTAD2	J9	I	LVTTTL	Port address bit 2 (LOW = 0). Internally pulled down.
PRTAD3	J8	I	LVTTTL	Port address bit 3 (LOW = 0). Internally pulled low.
PRTAD4	L7	I	LVTTTL	Port address bit 4 (LOW = 0). Internally pulled low.
RESETN	K4	I	LVTTTL	Global chip reset. Active LOW. Schmitt trigger. Internally pulled up. Reset is required after power up for proper operation.
RXALARM	C5	O	LVTTTL (open drain)	Logical OR for alarms in register 1E×9003 and as enabled by register 1E×9000. Open-drain output requires external pull-up resistor.
SPLITLOOP N	E5	I	LVTTTL	Enables simultaneous system and network loopback paths J and K, respectively. 1: Normal operation. 0: Loopbacks J and K enabled. Internally pulled high.
TXALARM	D4	O	LVTTTL (open drain)	Logical OR for alarms in register 1E×9004 and as enabled by register 1E×9001. Open-drain output requires external pull-up resistor. Alternate GPO or Tx link/activity LED driver.
WIS_INTA	C6	O	LVTTTL (open drain)	WIS interrupt A, part of extended WIS. Open-drain output requires external pull-up resistor. Alternate GPO or LED driver.
WIS_INTB	K6	O	LVTTTL (open drain)	WIS interrupt B, part of extended WIS. Open-drain output requires external pull-up resistor. Alternate GPO or LED driver.

6.2.6 Phase-Locked Loop Filter Capacitors

The following table lists the pins associated with phase-locked loop filter capacitors.

Table 313 • Phase-Locked Loop Filter Capacitor Pins

Name	Number	I/O	Type	Description
CMUFILT	G1		Analog	CMU filter connect capacitor (1 μ F) from this pin to ground
CRUFILT	L2		Analog	CRU filter capacitor (1 μ F) from this pin to ground

6.2.7 JTAG Interface

The following table lists the pins that control the JTAG test access port.

Table 314 • JTAG Interface Pins

Name	Number	I/O	Type	Description
TCK	L5	I	LVTTL	JTAG test access port test clock input. Internally pulled up.
TDI	M4	I	LVTTL	JTAG test access port test data input. Internally pulled up.
TDO	M3	O	LVTTL	JTAG test access port test data output.
TMS	L4	I	LVTTL	JTAG test access port test mode select input. Internally pulled up.
TRSTB	M5	I	LVTTL	JTAG test access port test logic reset input. Internally pulled up. For TAP controller reset, this input must be pulled low. In normal operation, this pin should be connected to ground.

6.2.8 Power and Ground

The following table lists the pins used for power and ground.

Table 315 • Power and Ground Pins

Name	Number	I/O	Description
VDD12PCS	E6 F6 G6 H6 J6	Power	1.2 V power supply (PCS).
VDD12RX	H4 J4	Power	1.2 V power for PMA serial 10-gigabit Rx.
VDD12TX	E4 F4	Power	1.2 V power for PMA serial 10-gigabit Tx.
VDD12X	E9 F9 G9 H9	Power	1.2 V power supply for XAUI I/O.
VDDA12	E8 F8 G8 H8	Power	1.2 V analog power supply for XAUI I/O.
VDDTTL	F5 J5	Power	TTL power supply (1.2 V, 1.5 V, 1.8 V, or 3.3 V).

Table 315 • Power and Ground Pins (continued)

Name	Number	I/O	Description
VSS	A2, A5, A8, A11, B2, B3, B5, B8, B9, B10, B11, C1, C2, C4, C12, D2, E2, E3, E7, E11, F1, F2, F7, F11, F12, G2, G4, G5, G7, G10, G12, H1, H2, H3, H5, H7, J11, K2, K5, K11, K12, L1, L3, L6, L9, L10, M1, M2, M8	GND	Ground.

6.2.9 Miscellaneous Pins

The following table lists the miscellaneous pins used for the VSC8486-11 device.

Table 316 • Miscellaneous

Name	Number	I/O	Description
Reserved	B6, B7, D5, F10, M11	NC	No connect

7 Package Information

The VSC8486-11 device is available in three package types. VSC8486JB-11 is a 144-pin, flip chip ball grid array (FCBGA) with a 13 mm × 13 mm body size, 1 mm pin pitch, and 1.4 mm maximum height. The device is also available in lead-free (Pb-free) packages, VSC8486XJB-11 and VSC8486YJB-11. Note that for VSC8486XJB-11, only the second-level interconnect is lead-free.

Lead-free products from Microsemi comply with the temperatures and profiles defined in the joint IPC and JEDEC standard IPC/JEDEC J-STD-020. For more information, see the IPC and JEDEC standard.

This section provides the package drawing, thermal specifications, and moisture sensitivity rating for the VSC8486-11 device.

7.1 Package Drawing

The following illustration shows the package drawing for the VSC8486-11 device. The drawing contains the top view, bottom view, side view, dimensions, tolerances, and notes.

Figure 64 • Package Drawing

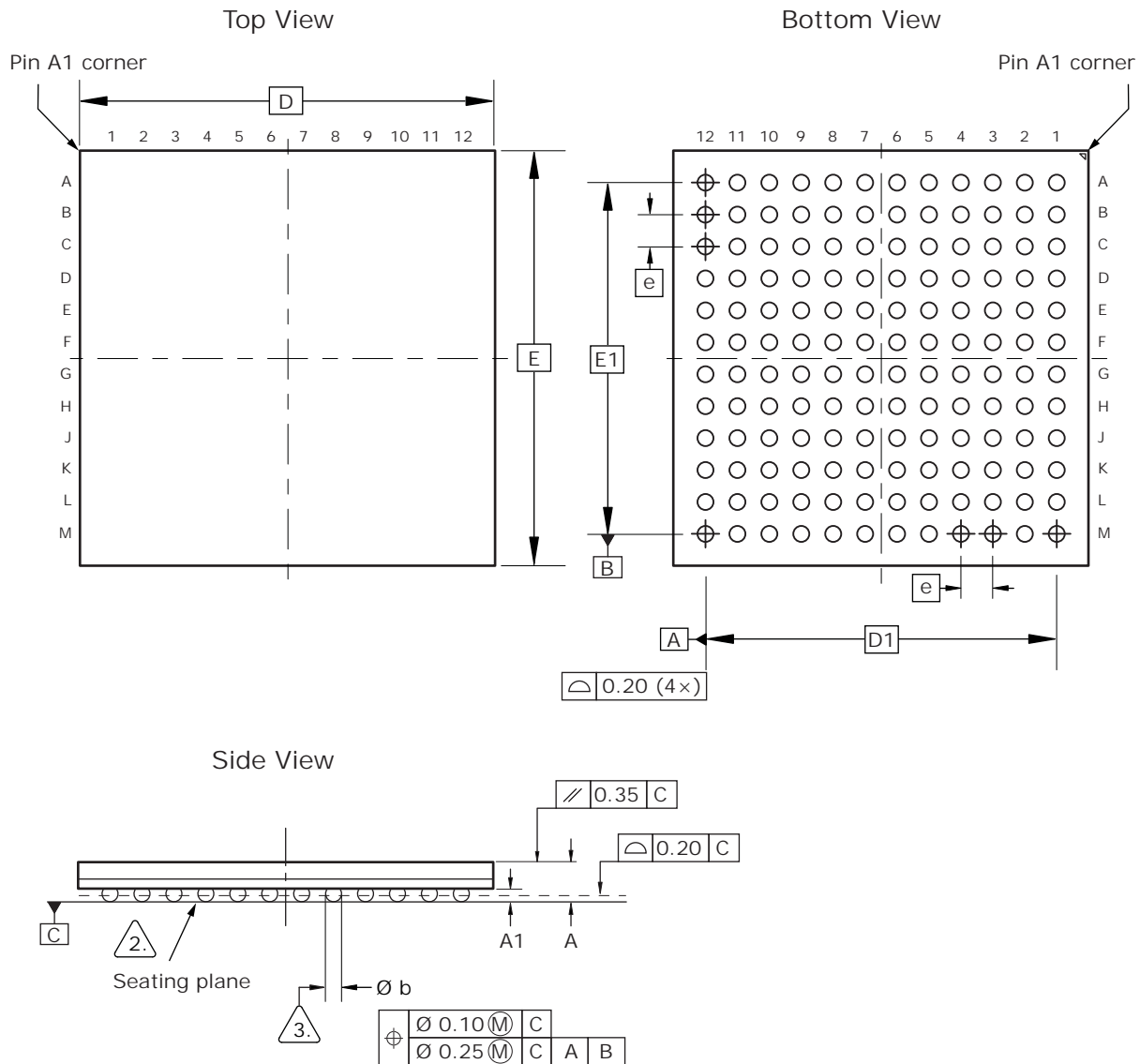

Notes

- All dimensions and tolerances are in millimeters (mm).
- Primary datum C and seating plane are defined by the spherical crowns of the solder balls.
- Dimension b is measured at the maximum solder ball diameter, parallel to primary datum C.
- Radial true position is represented by typical values.

Dimensions and Tolerances

Reference	Minimum	Nominal	Maximum
A			1.40
A1	0.36		0.46
D		13.00 BSC	
E		13.00 BSC	
D1		11.00 BSC	
E1		11.00 BSC	
e		1.00 BSC	
b	0.44	0.50	0.64

7.2 Thermal Specifications

Thermal specifications for this device are based on the JEDEC standard EIA/JESD51-2 and have been modeled using a four-layer test board with two signal layers, a power plane, and a ground plane (2s2p PCB). For more information, see the JEDEC standard.

Table 317 • Thermal Resistances

Part Order Number	θ_{JC}	θ_{JB}	θ_{JA} ($^{\circ}C/W$) vs. Airflow (ft/min)		
			0	100	200
VSC8486JB-11	3.6	18	32	27.9	25.7
VSC8486XJB-11	3.6	18	32	27.9	25.7
VSC8486YJB-11	3.6	18	32	27.9	25.7

To achieve results similar to the modeled thermal resistance measurements, the guidelines for board design described in the JEDEC standard EIA/JESD51 series must be applied. For information about specific applications, see the following:

EIA/JESD51-5, *Extension of Thermal Test Board Standards for Packages with Direct Thermal Attachment Mechanisms*

EIA/JESD51-7, *High Effective Thermal Conductivity Test Board for Leaded Surface Mount Packages*

EIA/JESD51-9, *Test Boards for Area Array Surface Mount Package Thermal Measurements*

EIA/JESD51-10, *Test Boards for Through-Hole Perimeter Leaded Package Thermal Measurements*

EIA/JESD51-11, *Test Boards for Through-Hole Area Array Leaded Package Thermal Measurements*

7.3 Moisture Sensitivity

This device is rated moisture sensitivity level 4 as specified in the joint IPC and JEDEC standard IPC/JEDEC J-STD-020. For more information, see the IPC and JEDEC standard.

8 Design Guidelines

This section provides recommended guidelines for designing with the VSC8486-11 device.

8.1 Power Supply Connection

In XAUI mode, the VSC8486-11 operates from a single 1.2 V power supply. A 3.3 V LVTTTL power supply is used to provide a compatible interface to other devices using low-speed LVTTTL I/O. There are no power supply sequence requirements for the VSC8486-11.

Functional power groups and associated pin locations are summarized in the following table.

Table 318 • Power Supply and Pin Locations

Power Supply (DC)	VSC8486-11 Subsystem	Group Name	Pin Locations	Typical Group Supply Current (LAN Mode)
1.2 V	10-gigabit VCO and Rx PLL	VDD12RX	H4, J4	110 mA
1.2 V	10-gigabit VCO and Tx PLL	VDD12TX	E4, F4	65 mA
1.2 V	XAUI Analog and PLL	VDDA12	F8, G8, H8, E8	70 mA
1.2 V	XAUI	VDD12X	E9, F9, G9, H9	100 mA
1.2 V	PCS	VDD12PCS	E6, F6, G6, H6, J6	220 mA
3.3 V	LVTTTL I/O	VDDTTL	F5, J5	5 mA
GND		GND	A2, A5, A8, A11, B2, B3, B5, B8, B9, B10, B11, C1, C2, C4, C12, D2, E2, E3, E7, E11, F1, F2, F7, F11, F12, G2, G4, G5, G7, G10, G12, H1, H2, H3, H5, H7, J11, K2, K5, K11, K12, L1, L3, L6, L9, L10, M1, M2, M8	Not applicable

The recommended filter structures for the VSC8486-11 functional power supply groups are shown in the following illustration. Although not shown, it is recommended each power supply pin have a 0402 size, XR7 dielectric, 0.01 μ F ceramic capacitor. Place these capacitors in the pin field, close to the nearest ground pin to minimize connection traces and associated inductance.

Figure 65 • Recommended Power Supply Isolation Schematic

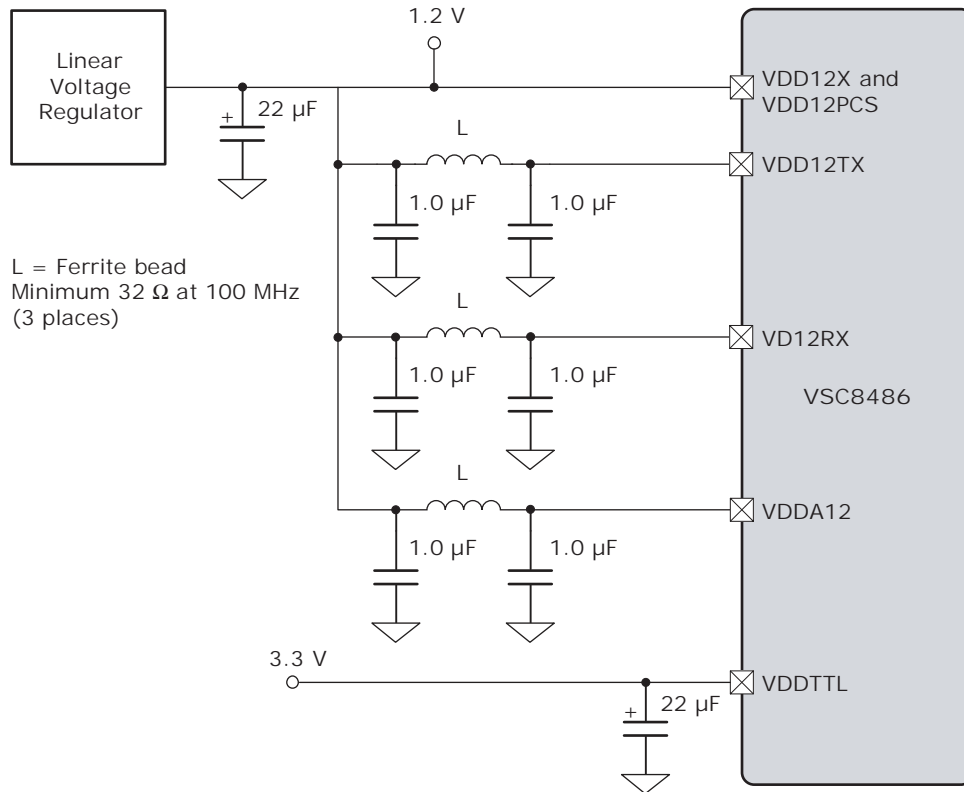

9 Ordering Information

The VSC8486-11 device is available in three package types. VSC8486JB-11 is a 144-pin, flip chip ball grid array (FCBGA) with a 13 mm × 13 mm body size, 1 mm pin pitch, and 1.4 mm maximum height. The device is also available in lead-free (Pb-free) packages, VSC8486XJB-11 and VSC8486YJB-11. Note that for VSC8486XJB-11, only the second-level interconnect is lead-free.

Lead-free products from Microsemi comply with the temperatures and profiles defined in the joint IPC and JEDEC standard IPC/JEDEC J-STD-020. For more information, see the IPC and JEDEC standard.



The following table lists the ordering information for the VSC8486-11 device.

Table 319 • Ordering Information

Part Order Number	Description
VSC8486JB-11	144-pin FCBGA with a 13 mm × 13 mm body size, 1 mm pin pitch, and 1.4 mm maximum height
VSC8486XJB-11	Lead-free (second-level interconnect only), 144-pin FCBGA with a 13 mm × 13 mm body size, 1 mm pin pitch, and 1.4 mm maximum height
VSC8486YJB-11	Lead-free, 144-pin FCBGA with a 13 mm × 13 mm body size, 1 mm pin pitch, and 1.4 mm maximum height

Looking for pricing, stock, or lifecycle information?

Click below to explore more details on WIN SOURCE:

-  [View VSC8486YJB-11 on WIN SOURCE](#)
-  [Microchip Technology](#) Information

Optimize Your Supply Chain with WIN SOURCE Solutions

-  Global Sourcing Solution
-  Obsolete Management
-  Cost Control Management
-  Shortage Management
-  Alternative Solution
-  Excess Inventory Management