



**THE DATASHEET OF
FLS6617MX**



FLS6617

Primary-Side Regulation PWM with Power MOSFET Integrated

Description

This third-generation Primary Side Regulation (PSR) and highly integrated PWM controller provides several features to enhance the performance of low-power flyback converters. The proprietary TRUECURRENT[®] technology of FLS6617 enables precise CC regulation and simplified circuit design for battery-charger applications leading to lower-cost, smaller, and lighter chargers, compared to a conventional design or a linear transformer.

To minimize standby power consumption, the proprietary green mode provides off-time modulation to linearly decrease PWM frequency under light-load conditions. Green mode assists the power supply in meeting power conservation requirements.

By using the FLS6617, a charger can be implemented with few external components and minimized cost. A typical output CV/CC characteristic envelope is shown in Figure 1.

Features

- Low Standby Power under 30 mW
- High-Voltage Startup
- Fewest External Component Counts
- Constant-Voltage (CV) and Constant-Current (CC) Control without Secondary-Feedback Circuitry
- Green-Mode: Linearly Decreasing PWM Frequency with Cycle Skipping
- Fixed PWM Frequency at 50 kHz with Proprietary Frequency Hopping to Solve EMI Problem
- Peak-Current-Mode Control in CV Mode
- Cycle-by-Cycle Current Limiting
- V_{DD} Over-Voltage Protection with Auto Restart
- V_{DD} Under-Voltage Lockout (UVLO)
- Gate Output Maximum Voltage Clamped at 15 V
- Fixed Over-Temperature Protection with Auto Restart
- Available in the 7-Lead SOP Package
- These Devices are Pb-Free, Halogen Free/BFR Free and are RoHS Compliant

Applications

- Battery Chargers for Cellular Phones, Cordless Phones, PDA, Digital Cameras, Power Tools, etc.
- Replaces Linear Transformers and RCC SMPS



ON Semiconductor[®]

www.onsemi.com

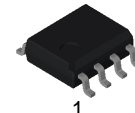

SOIC7
CASE 751ED

MARKING DIAGRAM

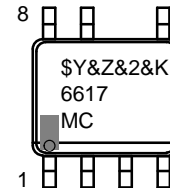

\$Y	= ON Semiconductor Logo
&Z	= Assembly Plant Code
&2	= Numeric Date Code
&K	= Lot Code
6617	= Specific Device Code

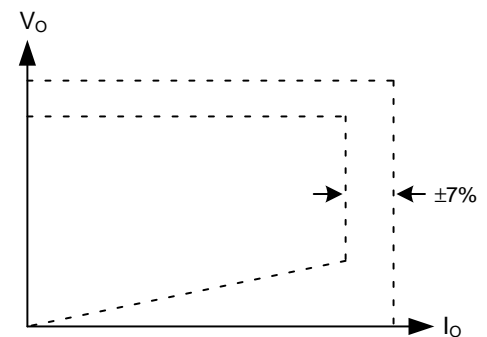

Figure 1. Typical Output V-I Characteristic

ORDERING INFORMATION

See detailed ordering and shipping information on page 2 of this data sheet.

FLS6617

ORDERING INFORMATION

Part Number	Operating Temperature Range	Package	Shipping†
FLS6617MX	-40°C to 125°C	SOIC7 (Pb-Free)	2500 Units / Tape & Reel

†For information on tape and reel specifications, including part orientation and tape sizes, please refer to our Tape and Reel Packaging Specification Brochure, BRD8011/D.

Application Diagram

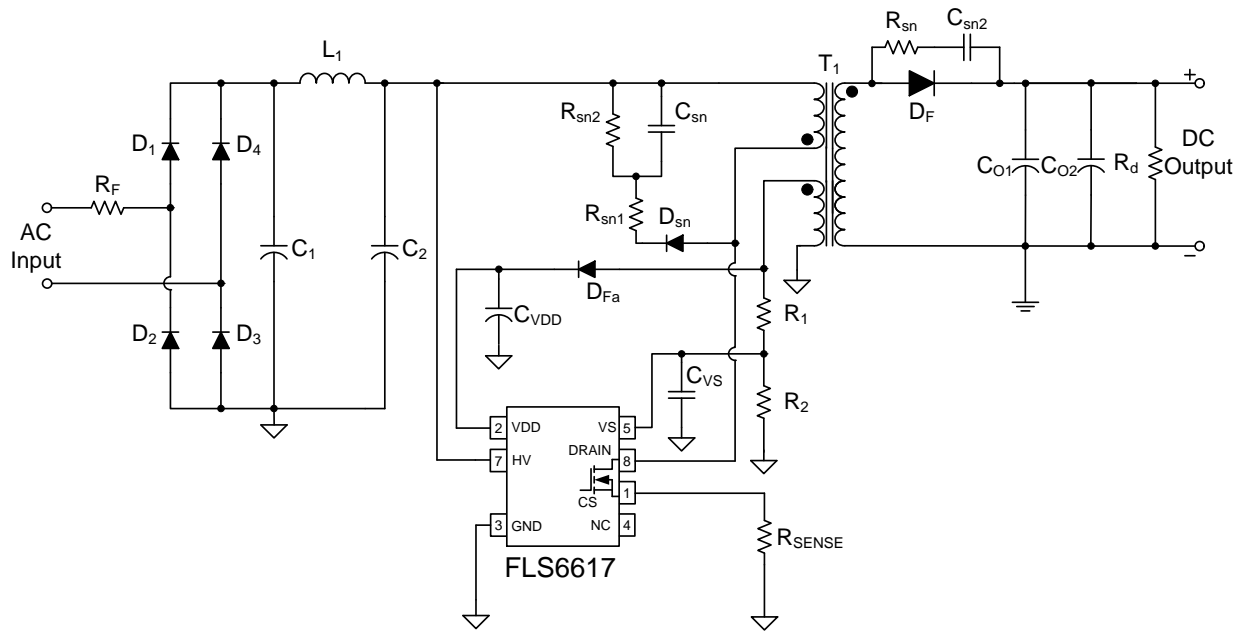

Figure 2. Application Diagram

FLS6617

Internal Block Diagram

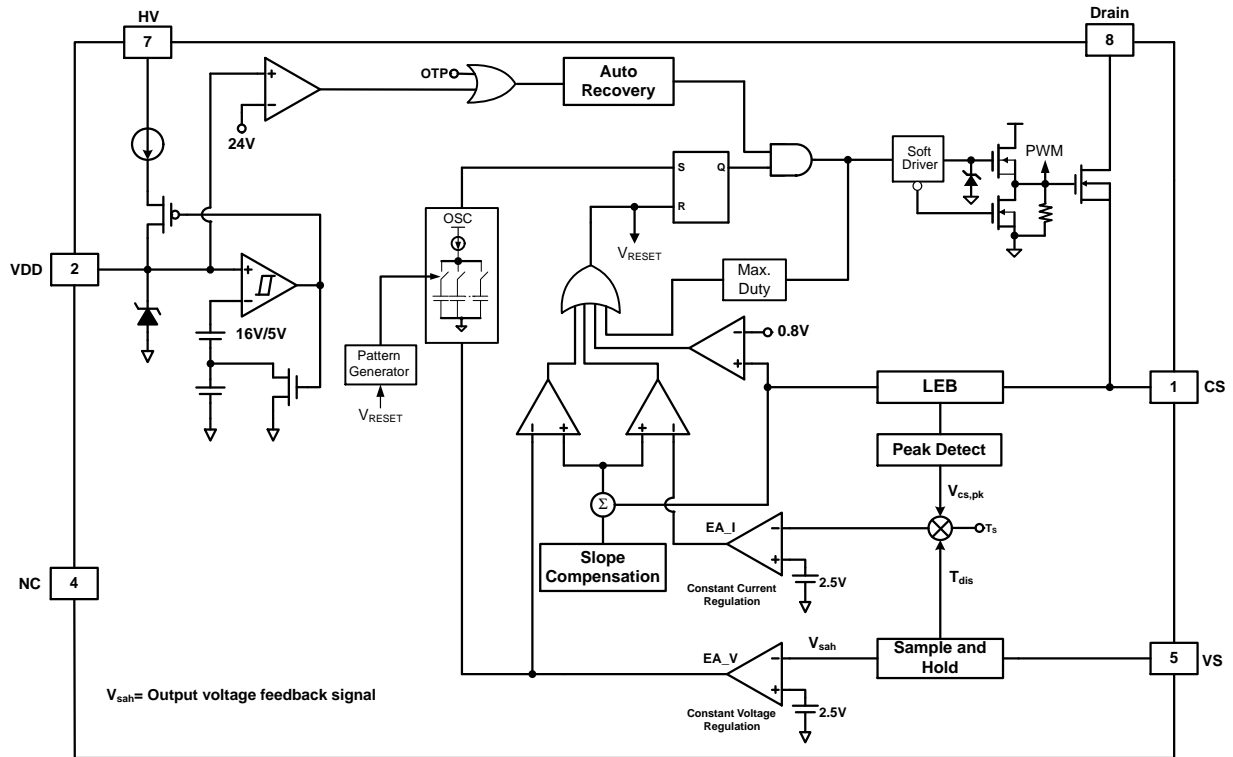

Figure 3. Functional Block Diagram

Pin Configuration

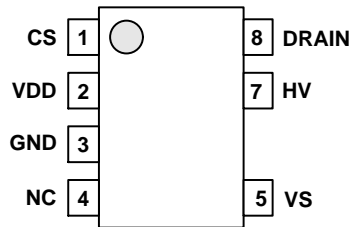

Figure 4. Pin Configuration

PIN DEFINITIONS

Pin #	Name	Description
1	CS	Current Sense. This pin connects to current-sense resistor. Detect the MOSFET current for peak-current-mode control in CV mode and provide the output-current regulation in CC mode.
2	VDD	Power Supply. IC operating current and MOSFET driving current are supplied through this pin. This pin is connected to an external V _{DD} capacitor of typically 10 μF. The threshold voltages for startup and turn-off are 16 V and 5 V, respectively. The operating current is lower than 5 mA.
3	GND	Ground
4	NC	No Connection
5	VS	Voltage Sense. This pin detects the output voltage information and discharge time based on voltage of auxiliary winding.
7	HV	High Voltage. This pin connects to bulk capacitor for high-voltage startup.
8	DRAIN	Driver Output. Power MOSFET drain. This pin is the high-voltage power MOSFET drain.

FLS6617

ABSOLUTE MAXIMUM RATINGS

Symbol	Parameter	Min.	Max.	Units
V _{HV}	HV Pin Input Voltage		500	V
V _{VDD}	DC Supply Voltage (1, 2)		30	V
V _{VS}	VS Pin Input Voltage	-0.3	6.0	V
V _{CS}	CS Pin Input Voltage	-0.3	6.0	V
V _{COMV}	Voltage Error Amplifier Output Voltage	-0.3	6.0	V
V _{COMI}	Current Error Amplifier Output Voltage	-0.3	6.0	V
V _{DS}	Drain-Source Voltage		700	V
I _D	Continuous Drain Current	T _A = 25°C	1	A
		T _A = 100°C	0.6	A
I _{DM}	Pulsed Drain Current		4	A
E _{AS}	Single Pulse Avalanche Energy		50	mJ
I _{AR}	Avalanche Current		1	A
P _D	Power Dissipation (T _A < 50°C)		660	mW
θ _{JA}	Thermal Resistance (Junction-to-Air)		147	°C/W
ψ _{JT}	Thermal Resistance (Junction-to-Case)		11	°C/W
T _J	Operating Junction Temperature	-40	+150	°C
T _{STG}	Storage Temperature Range	-55	+150	°C
T _L	Lead Temperature (Wave Soldering or IR, 10 Seconds)		+260	°C
ESD	Electrostatic Discharge Capability (Except HV Pin)	Human Body Model, JEDEC-JESD22_A114	4.0	kV
		Charged Device Model, JEDEC-JESD22_C101	2.0	

Stresses exceeding those listed in the Maximum Ratings table may damage the device. If any of these limits are exceeded, device functionality should not be assumed, damage may occur and reliability may be affected.

1. Stresses beyond those listed under Absolute Maximum Ratings may cause permanent damage to the device.
2. All voltage values, except differential voltages, are given with respect to the GND pin.

RECOMMENDED OPERATING CONDITIONS

Symbol	Parameter	Min.	Max.	Units
T _A	Operating Ambient Temperature	-40	125	°C

Functional operation above the stresses listed in the Recommended Operating Ranges is not implied. Extended exposure to stresses beyond the Recommended Operating Ranges limits may affect device reliability.

FLS6617

ELECTRICAL CHARACTERISTICS

Unless otherwise specified, $V_{DD} = 15\text{ V}$ and $T_A = 25^\circ\text{C}$

Symbol	Parameter	Condition	Min.	Typ.	Max.	Unit
V_{DD} Section						
V_{OP}	Continuously Operating Voltage				23	V
V_{DD-ON}	Turn-On Threshold Voltage		15	16	17	V
V_{DD-OFF}	Turn-Off Threshold Voltage		4.5	5.0	5.5	V
I_{DD-OP}	Operating Current			2.5	5.0	mA
$I_{DD-GREEN}$	Green-Mode Operating Supply Current			0.95	1.2	mA
V_{DD-OVP}	V_{DD} Over-Voltage-Protection Level (OVP)			24		V
$t_{D-VDDOVP}$	V_{DD} Over-Voltage-Protection Debounce Time		90	200	350	μs

HV Startup Current Source Section

V_{HV-MIN}	Minimum Startup Voltage on HV Pin ⁽³⁾				50	V
I_{HV}	Supply Current Drawn from HV Pin	$V_{AC} = 90\text{ V}$ ($V_{DC} = 100\text{ V}$), $V_{DD} = 0\text{ V}$	1	2.0	5.0	mA
I_{HV-LC}	Leakage Current after Startup	$HV = 500\text{ V}$, $V_{DD} = V_{DD-OFF} + 1\text{ V}$		0.5	3.0	μA

Oscillator Section

f_{OSC}	Normal Frequency 1	Center Frequency	$> V_o * 0.78$	44	50	56	kHz
		Frequency Hopping Range		± 1.6	± 3.4	± 5.2	
	Normal Frequency 2	Center Frequency	$< V_o * 0.78$		36		
		Frequency Hopping Range			± 2.5		
$V_{F-JUM-53}$	Frequency Jumping Point	50 kHz \rightarrow 36 kHz, V_s	1.75	1.95	2.15	V	
$V_{F-JUM-35}$		36 kHz \rightarrow 50 kHz, V_s	2.05	2.25	2.45	V	
$f_{OSC-N-MIN}$	Minimum Frequency at No-Load		270	395	520	Hz	
$f_{OSC-CM-MIN}$	Minimum Frequency at CCM			13		kHz	
$V_{S-F-SKIPH}$	COMV Level for High Cycle Skipping Period Change ⁽³⁾			1.14		V	
$V_{S-F-SKIPL}$	COMV Level for Low Cycle Skipping Period Change ⁽³⁾			0.80		V	
$T_{SKIP-CV}$	Cycle skipping period ⁽³⁾	$V_{S-F-SKIPH} < COMV < V_N$		240		ms	
		$V_{S-F-SKIPL} > COMV$		160		ms	
f_{DV}	Frequency Variation vs. V_{DD} Deviation	$V_{DD} = 10\text{ V}, 25\text{ V}$		1	2	%	
f_{DT}	Frequency Variation vs. Temperature Deviation	$T_A = -40^\circ\text{C}$ to 105°C			15	%	

Voltage-Sense Section

I_{tc}	IC Bias Current			10		μA
$V_{BIAS-COMV}$	Adaptive Bias Voltage Dominated by V_{COMV}	$R_{VS} = 20\text{ k}\Omega$		1.4		V

Current-Sense Section

t_{PD}	Propagation Delay to GATE Output			90	200	ns
t_{MIN-N}	Minimum On Time at No-Load		700	850	1050	ns
V_{TH}	Threshold Voltage for Current Limit			0.8		V

Voltage Error Amplifier Section

V_{VR}	Reference Voltage		2.475	2.500	2.525	V
----------	-------------------	--	-------	-------	-------	---

FLS6617

ELECTRICAL CHARACTERISTICS (continued)

Unless otherwise specified, $V_{DD} = 15\text{ V}$ and $T_A = 25^\circ\text{C}$

Symbol	Parameter	Condition	Min.	Typ.	Max.	Unit
V_N	Green-Mode Starting Voltage on EA_V	$f_{OSC} = \text{Normal Frequency } 1 - 2\text{ kHz}$		2.5		V
V_G	Green-Mode Ending Voltage on EA_V	$f_{OSC} = 1\text{ kHz}$		0.5		V

Current Error Amplifier Section

V_{IR}	Reference Voltage		2.475	2.500	2.525	V
----------	-------------------	--	-------	-------	-------	---

Internal MOSFET Section (Note 4)

DCY_{MAX}	Maximum Duty Cycle		60	75	85	%
BV_{DSS}	Drain-Source Breakdown Voltage	$I_D = 250\ \mu\text{A}, V_{GS} = 0\text{ V}$	700			V
$\Delta BV_{DSS}/\Delta T_J$	Breakdown Voltage Temperature Coefficient	$I_D = 250\ \mu\text{A}$, Referenced to $T_A = 25^\circ\text{C}$		0.53		$V/^\circ\text{C}$
$R_{DS(ON)}$	Static Drain-Source On-Resistance	$I_D = 0.5\text{ A}, V_{GS} = 10\text{ V}$		13	16	Ω
I_S	Maximum Continuous Drain-Source Diode Forward Current				1	A
I_{DSS}	Drain-Source Leakage Current	$V_{DS} = 700\text{ V}, T_A = 25^\circ\text{C}$			10	μA
		$V_{DS} = 560\text{ V}, T_A = 100^\circ\text{C}$			100	
t_{D-ON}	Turn-On Delay Time	$V_{DS} = 350\text{ V}, I_D = 1\text{ A}, R_G = 25\ \Omega$ (Note 5)		10	30	ns
t_{D-OFF}	Turn-Off Delay Time			20	50	ns
C_{ISS}	Input Capacitance	$V_{GS} = 0\text{ V}, V_{DS} = 25\text{ V}, f_S = 1\text{ MHz}$		175	200	pF
C_{OSS}	Output Capacitance			23	25	pF

Over-Temperature Protection Section

T_{OTP}	Threshold Temperature for OTP (Note 6)			140		$^\circ\text{C}$
-----------	--	--	--	-----	--	------------------

Product parametric performance is indicated in the Electrical Characteristics for the listed test conditions, unless otherwise noted. Product performance may not be indicated by the Electrical Characteristics if operated under different conditions.

3. Guaranteed by design.

4. These parameters, although guaranteed, are not 100% tested in production.

5. Pulse test: pulse width $\leq 300\ \mu\text{s}$, duty cycle $\leq 2\%$.

6. When the over-temperature protection is activated, the power system enter auto-restart mode and output is disabled.

TYPICAL PERFORMANCE CHARACTERISTICS

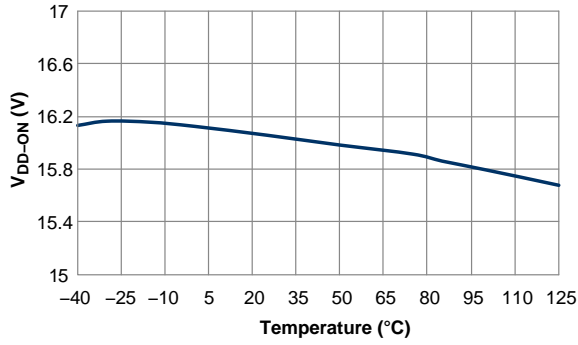

Figure 5. Turn-on Threshold Voltage (V_{DD-ON}) vs. Temperature

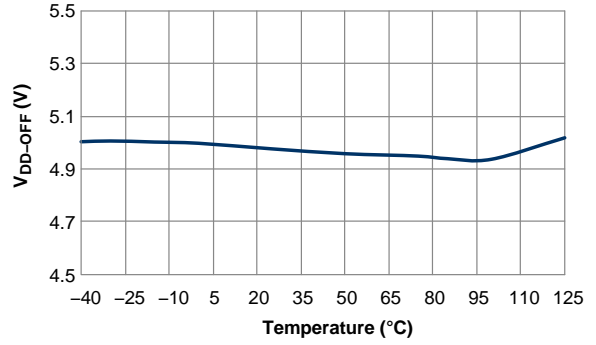

Figure 6. Turn-off Threshold Voltage (V_{DD-OFF}) vs. Temperature

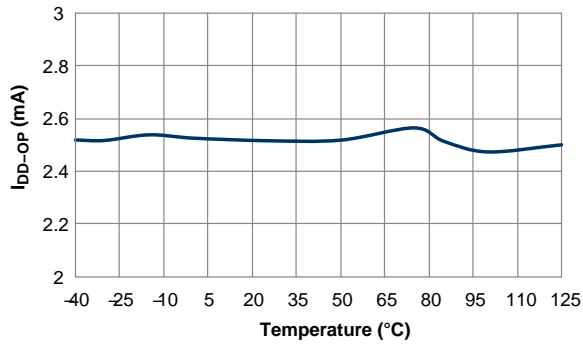

Figure 7. Operating Current (I_{DD-OP}) vs. Temperature

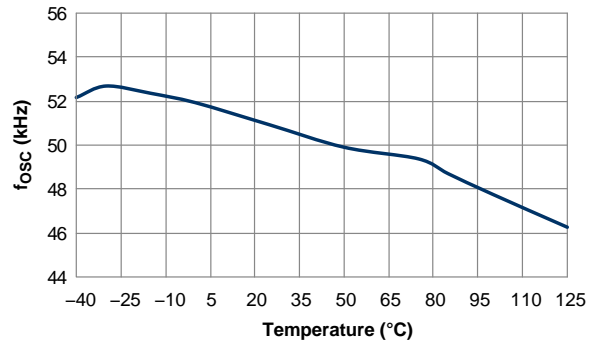

Figure 8. Normal Frequency 1 (f_{OSC}) vs. Temperature

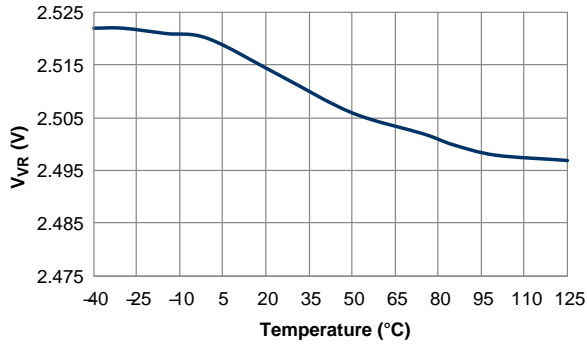

Figure 9. Reference Voltage (V_{VR}) vs. Temperature

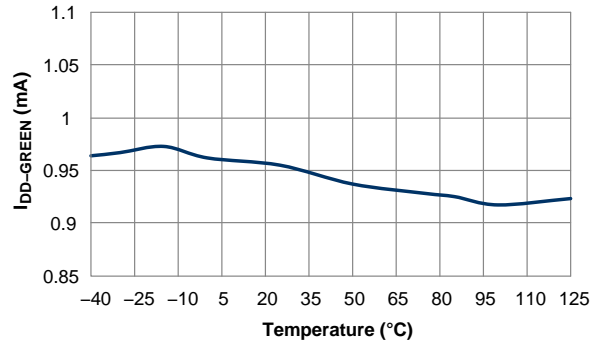

Figure 10. Green Mode Operating Supply Current (I_{DD-GREEN}) vs. Temperature

TYPICAL PERFORMANCE CHARACTERISTICS

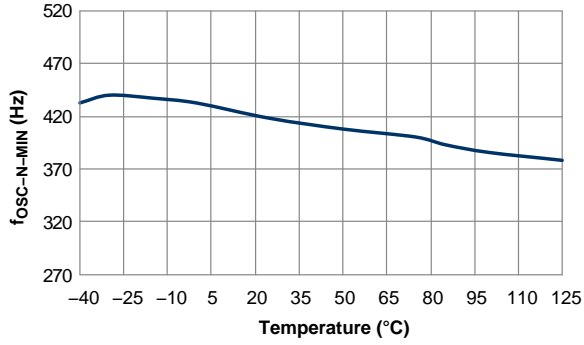

Figure 11. Minimum Frequency at No Load (f_{OSC-N-MIN}) vs. Temperature

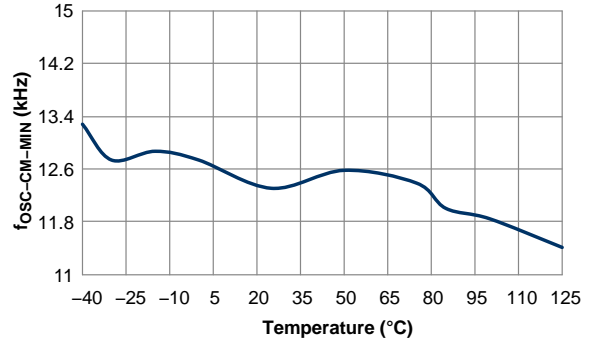

Figure 12. Minimum Frequency at CCM (f_{OSC-CM-MIN}) vs. Temperature

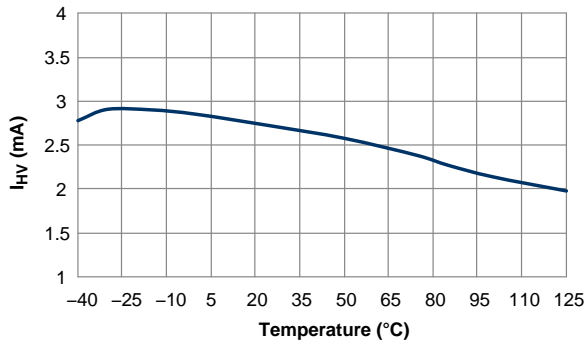

Figure 13. Supply Current Drawn from HV Pin (I_{HV}) vs. Temperature

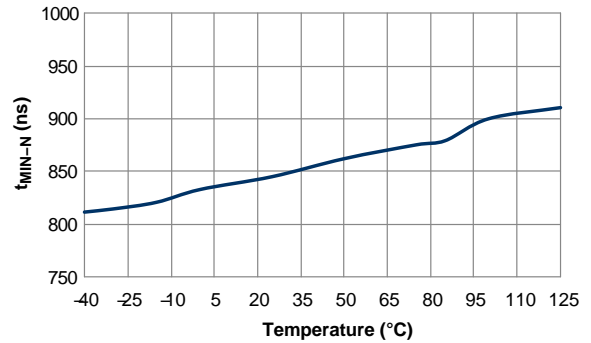

Figure 14. Minimum On Time at No Load (t_{MIN-N}) vs. Temperature

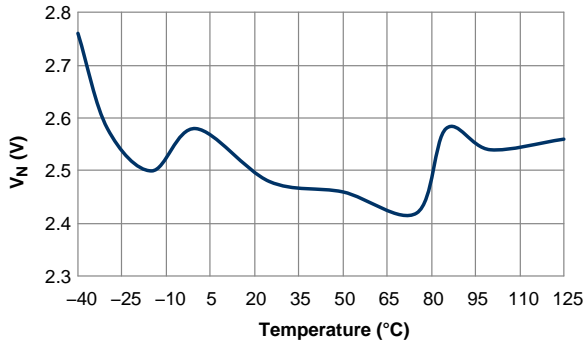

Figure 15. Green Mode Starting Voltage on EA_V (V_N) vs. Temperature

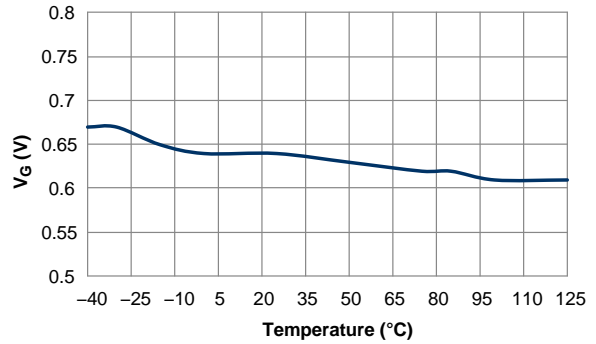

Figure 16. Green Mode Ending Voltage on EA_V (V_G) vs. Temperature

TYPICAL PERFORMANCE CHARACTERISTICS

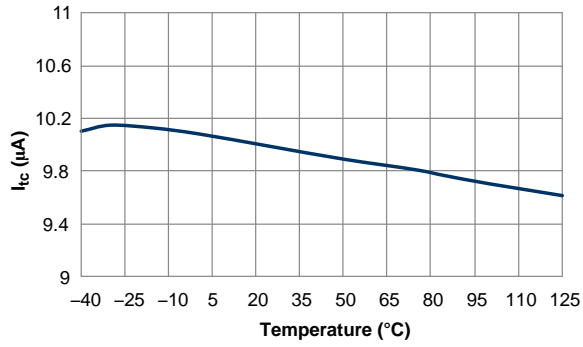

Figure 17. IC Bias Current (I_{tc}) vs. Temperature

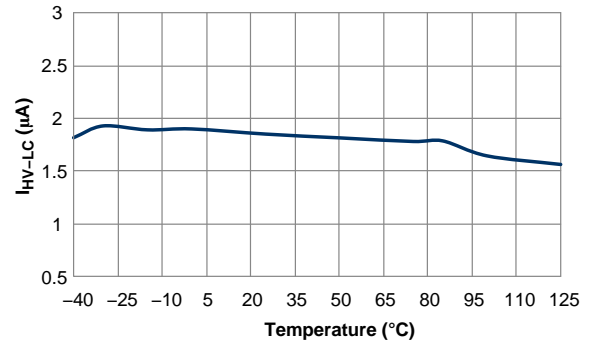

Figure 18. Leakage Current after Startup (I_{HV-LC}) vs. Temperature

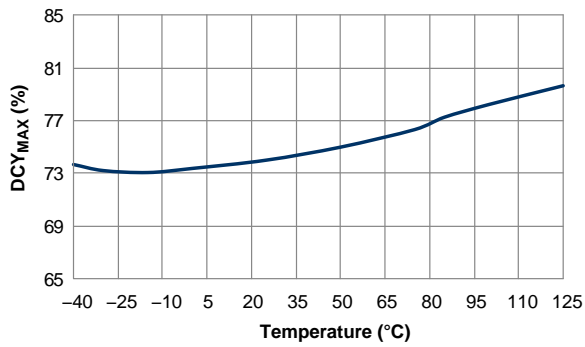

Figure 19. Maximum Duty Cycle (DCY_{MAX}) vs. Temperature

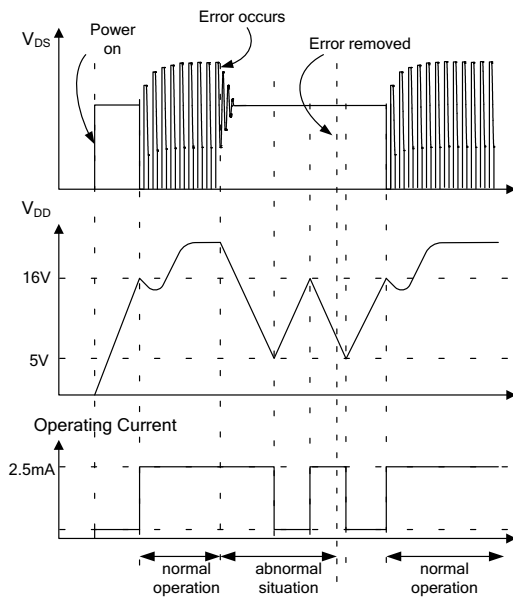

Figure 24. Auto-Restart Operation

V_{DD} Over-Voltage Protection (OVP)

V_{DD} over-voltage protection prevents damage from overvoltage conditions. If the V_{DD} voltage exceeds 24 V at open-loop feedback condition, OVP is triggered and the PWM switching is disabled. The OVP has a debounce time (typically 200 μs) to prevent false triggering due to switching noises.

Over-Temperature Protection (OTP)

The built-in temperature-sensing circuit shuts down PWM output if the junction temperature exceeds 140°C.

Pulse-by-pulse Current Limit

When the sensing voltage across the current-sense resistor exceeds the internal threshold of 0.8 V, the MOSFET is turned off for the remainder of switching cycle. In normal operation, the pulse-by-pulse current limit is not triggered since the peak current is limited by the control loop.

Leading-Edge Blanking (LEB)

Each time the power MOSFET switches on, a turn-on spike occurs at the sense resistor. To avoid premature termination of the switching pulse, a leading-edge blanking time is built in. During this blanking period, the current-limit comparator is disabled and cannot switch off the gate driver. As a result conventional RC filtering can be omitted.

Gate Output

The FLS6617 output stage is a fast totem-pole gate driver. Cross conduction has been avoided to minimize heat dissipation, increase efficiency, and enhance reliability. The output driver is clamped by an internal 15 V Zener diode to protect the power MOSFET transistors against undesired over-voltage gate signals.

Built-In Slope Compensation

The sensed voltage across the current-sense resistor is used for current mode control and pulse-by-pulse current limiting. Built-in slope compensation improves stability and prevents sub-harmonic oscillations due to peak-current mode control. The FLS6617 has a synchronized, positive-slope ramp built-in at each switching cycle.

Noise Immunity

Noise from the current sense or the control signal can cause significant pulse width jitter, particularly in continuous-conduction mode. While slope compensation helps alleviate these problems, further precautions should still be taken. Good placement and layout practices should be followed. Avoiding long PCB traces and component leads, locating compensation and filter components near the FLS6617, and increasing the power MOS gate resistance are advised.

Operation Area

Figure 25 shows operation area. FLS6617 has two switching frequency (f_s) in constant current mode. In order to ensure IC can normally work at DCM under constant current mode, frequency will jump to lower level (36 kHz) when system is operated at low output voltage.

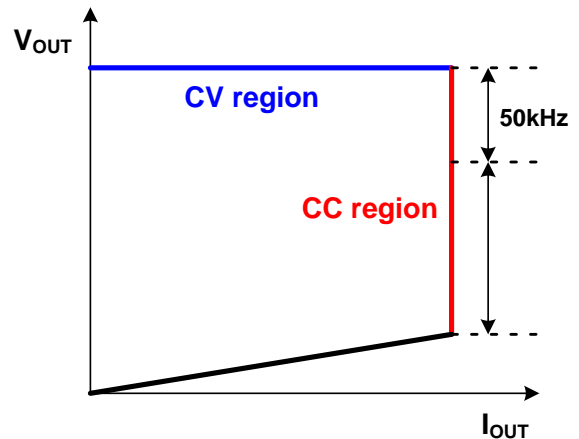

Figure 25. Operation Area

TRUECURRENT is a registered trademark of Semiconductor Components Industries, LLC (SCILLC) or its subsidiaries in the United States and/or other countries.

MECHANICAL CASE OUTLINE
PACKAGE DIMENSIONS

ON Semiconductor®



SOIC7
CASE 751ED
ISSUE O

DATE 30 SEP 2016

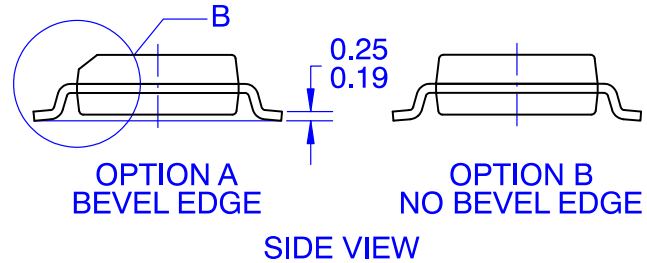
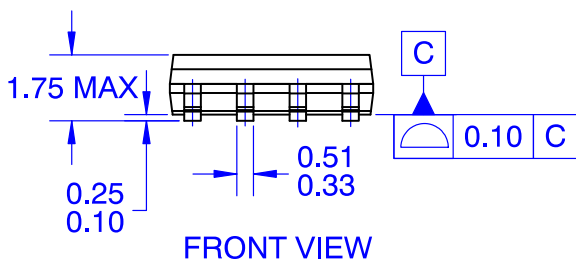
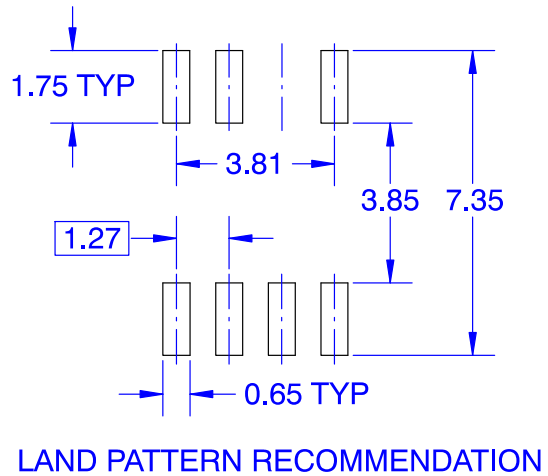
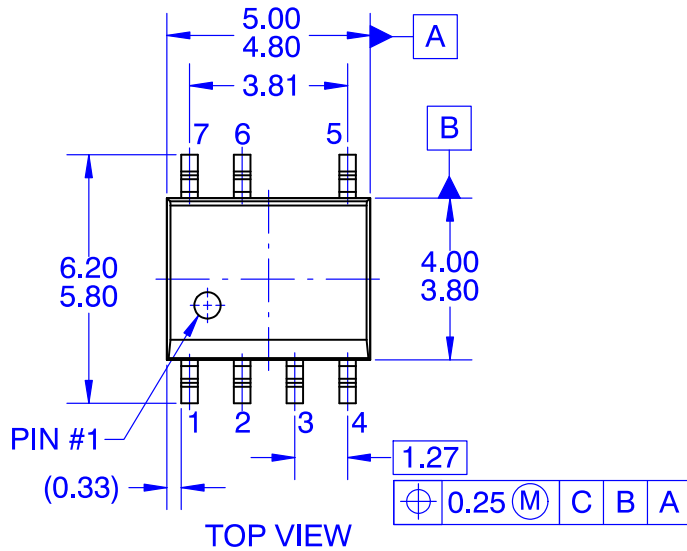

NOTES:

- A. THIS PACKAGE DOES NOT FULLY CONFORM TO JEDEC MS-012, VARIATION AA
- B. ALL DIMENSIONS ARE IN MILLIMETERS
- C. DIMENSIONS DO NOT INCLUDE MOLD FLASH OR BURRS

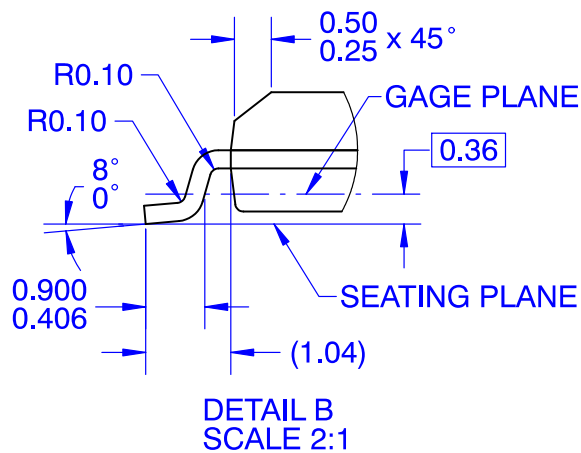

DOCUMENT NUMBER:	98AON13737G	Electronic versions are uncontrolled except when accessed directly from the Document Repository. Printed versions are uncontrolled except when stamped "CONTROLLED COPY" in red.
DESCRIPTION:	SOIC7	PAGE 1 OF 1

ON Semiconductor and are trademarks of Semiconductor Components Industries, LLC dba ON Semiconductor or its subsidiaries in the United States and/or other countries. ON Semiconductor reserves the right to make changes without further notice to any products herein. ON Semiconductor makes no warranty, representation or guarantee regarding the suitability of its products for any particular purpose, nor does ON Semiconductor assume any liability arising out of the application or use of any product or circuit, and specifically disclaims any and all liability, including without limitation special, consequential or incidental damages. ON Semiconductor does not convey any license under its patent rights nor the rights of others.

onsemi, **Onsemi**, and other names, marks, and brands are registered and/or common law trademarks of Semiconductor Components Industries, LLC dba "**onsemi**" or its affiliates and/or subsidiaries in the United States and/or other countries. **onsemi** owns the rights to a number of patents, trademarks, copyrights, trade secrets, and other intellectual property. A listing of **onsemi**'s product/patent coverage may be accessed at www.onsemi.com/site/pdf/Patent-Marking.pdf. **onsemi** reserves the right to make changes at any time to any products or information herein, without notice. The information herein is provided "as-is" and **onsemi** makes no warranty, representation or guarantee regarding the accuracy of the information, product features, availability, functionality, or suitability of its products for any particular purpose, nor does **onsemi** assume any liability arising out of the application or use of any product or circuit, and specifically disclaims any and all liability, including without limitation special, consequential or incidental damages. Buyer is responsible for its products and applications using **onsemi** products, including compliance with all laws, regulations and safety requirements or standards, regardless of any support or applications information provided by **onsemi**. "Typical" parameters which may be provided in **onsemi** data sheets and/or specifications can and do vary in different applications and actual performance may vary over time. All operating parameters, including "Typicals" must be validated for each customer application by customer's technical experts. **onsemi** does not convey any license under any of its intellectual property rights nor the rights of others. **onsemi** products are not designed, intended, or authorized for use as a critical component in life support systems or any FDA Class 3 medical devices or medical devices with a same or similar classification in a foreign jurisdiction or any devices intended for implantation in the human body. Should Buyer purchase or use **onsemi** products for any such unintended or unauthorized application, Buyer shall indemnify and hold **onsemi** and its officers, employees, subsidiaries, affiliates, and distributors harmless against all claims, costs, damages, and expenses, and reasonable attorney fees arising out of, directly or indirectly, any claim of personal injury or death associated with such unintended or unauthorized use, even if such claim alleges that **onsemi** was negligent regarding the design or manufacture of the part. **onsemi** is an Equal Opportunity/Affirmative Action Employer. This literature is subject to all applicable copyright laws and is not for resale in any manner.

ADDITIONAL INFORMATION

TECHNICAL PUBLICATIONS:

Technical Library: www.onsemi.com/design/resources/technical-documentation
onsemi Website: www.onsemi.com

ONLINE SUPPORT: www.onsemi.com/support

For additional information, please contact your local Sales Representative at www.onsemi.com/support/sales

Looking for pricing, stock, or lifecycle information?

Click below to explore more details on WIN SOURCE:

-  [View FLS6617MX on WIN SOURCE](#)
-  [Fairchild/ON Semiconductor Information](#)

Optimize Your Supply Chain with WIN SOURCE Solutions

-  Global Sourcing Solution
-  Obsolete Management
-  Cost Control Management
-  Shortage Management
-  Alternative Solution
-  Excess Inventory Management