

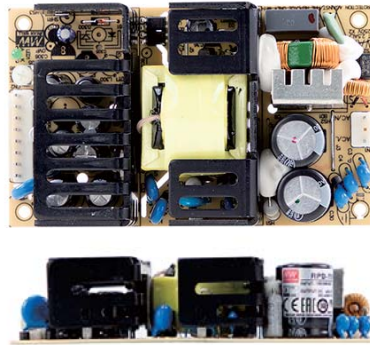

THE DATASHEET OF RPD-75B





■ Features

- 5"×3" compact size
- Medical safety approved (2 x MOPP) according to ANSI/AAMI ES60601-1 and IEC/BS EN/EN60601-1
- Suitable for BF application with appropriate system consideration
- Free air convection for rated power and 23.5CFM forced air convection for peak load
- EMI class B for class I configuration
- Extremely low leakage current
- Protections: Short circuit / Overload / Over voltage
- Lifetime > 140K hours
- 3 years warranty

■ Applications

- Oral irrigator
- Hemodialysis machine
- Medical computer monitors
- Sleep apnea devices

■ GTIN CODE

MW Search: <https://www.meanwell.com/serviceGTIN.aspx>

■ Description

RPD-75 is a 75W highly reliable green PCB type medical power supply with a high power density on the 5" by 3" footprint. It accepts 90~264VAC input and offers dual output voltages .

RPD-75 is able to be used for Class I (with FG) system design. The extremely low leakage current is less than 150µA. In addition, it conforms to international medical regulations (2*MOPP) and EMC BS EN/EN55011.

■ Model Encoding

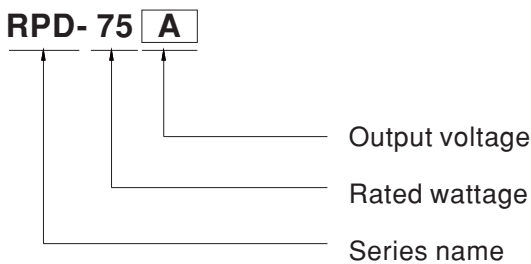

SPECIFICATION

MODEL	RPD-75A		RPD-75B		
OUTPUT	OUTPUT NUMBER	CH1	CH2	CH1	CH2
	DC VOLTAGE	5V	12V	5V	24V
	RATED CURRENT	7A	3A	5A	2A
	CURRENT RANGE	1 ~ 9.5A	0.3 ~ 4A	1 ~ 6.8A	0.2 ~ 2.7A
	RATED POWER	71W		73W	
	PEAK LOAD (23.5CFM)	95.5W		98.8W	
	RIPPLE & NOISE (max.) Note.2	80mVp-p	120mVp-p	80mVp-p	120mVp-p
	VOLTAGE ADJ. RANGE	CH1: 4.75 ~ 5.5V		CH1: 4.75 ~ 5.5V	
	VOLTAGE TOLERANCE Note.3	±2.0%	±6.0%	±2.0%	±6.0%
	LINE REGULATION	±0.5%	±1.0%	±0.5%	±1.0%
	LOAD REGULATION	±1.5%	±3.0%	±1.5%	±3.0%
SETUP, RISE TIME	500ms, 30ms/230VAC 500ms, 30ms/115VAC at full load				
HOLD UP TIME (Typ.)	90ms/230VAC 20ms/115VAC at full load				
INPUT	VOLTAGE RANGE	90 ~ 264VAC 127 ~ 370VDC			
	FREQUENCY RANGE	47 ~ 63Hz			
	EFFICIENCY (Typ.)	77%		79%	
	AC CURRENT (Typ.)	1.5A/115VAC 1A/230VAC			
	INRUSH CURRENT (Typ.)	COLD START 25A/115VAC 50A/230VAC			
	LEAKAGE CURRENT Note.4	Earth leakage current < 150 μA/264VAC , Touch current < 100 μA/264VAC			
PROTECTION	OVERLOAD	140 ~ 180% rated output power Protection type : Hiccup mode, recovers automatically after fault condition is removed			
	OVER VOLTAGE	Ch1: 5.7 ~ 6.8V Protection type : Shut down o/p voltage, re-power on to recover			
ENVIRONMENT	WORKING TEMP.	-20 ~ +70°C (Refer to "Derating Curve")			
	WORKING HUMIDITY	20 ~ 90% RH non-condensing			
	STORAGE TEMP., HUMIDITY	-40 ~ +85°C, 10 ~ 95% RH non-condensing			
	TEMP. COEFFICIENT	±0.03%/°C (0 ~ 50°C)			
	VIBRATION	10 ~ 500Hz, 2G 10min./1cycle, period for 60min. each along X, Y, Z axes			
	OPERATING ALTITUDE Note.5	3000 meters			
SAFETY & EMC (Note 8)	SAFETY STANDARDS	IEC 60601-1:2005+A1+A2, TUV BS EN/ EN 60601-1:2006+A1+A12+A2, ANSI/AAMI ES60601-1:2005+A2 CAN/CSA C22.2 No. 60601-1:2014+A2, EAC TP TC 004 approved; Design refer to BS EN/EN60335-1 (by request)			
	ISOLATION LEVEL	Primary-Secondary:2xMOPP, Primary-Earth:1xMOPP			
	WITHSTAND VOLTAGE	I/P-O/P:4KVAC I/P-FG:2KVAC O/P-FG:1.5KVAC			
	ISOLATION RESISTANCE	I/P-O/P, I/P-FG, O/P-FG:100M Ohms / 500VDC / 25°C / 70% RH			
	EMC EMISSION	Parameter	Standard	Test Level / Note	
		Conducted emission	BS EN/EN55011 (CISPR11)	Class B	
		Radiated emission	BS EN/EN55011 (CISPR11)	Class B	
		Harmonic current	BS EN/EN61000-3-2	Class A	
		Voltage flicker	BS EN/EN61000-3-3	-----	
	EMC IMMUNITY	BS EN/EN55035, BS EN/EN60601-1-2			
		Parameter	Standard	Test Level / Note	
		ESD	BS EN/EN61000-4-2	Level 4, 15KV air ; Level 4, 8KV contact	
		RF field susceptibility	BS EN/EN61000-4-3	Level 3, 10V/m(80MHz~2.7GHz) Table 9, 9~28V/m(385MHz~5.78GHz)	
		EFT bursts	BS EN/EN61000-4-4	Level 3, 2KV	
Surge susceptibility		BS EN/EN61000-4-5	Level 4, 4KV/Line-FG ; 2KV/Line-Line		
Conducted susceptibility		BS EN/EN61000-4-6	Level 3, 10V		
Magnetic field immunity		BS EN/EN61000-4-8	Level 4, 30A/m		
Voltage dip, interruption	BS EN/EN61000-4-11	100% dip 1 periods, 30% dip 25 periods, 100% interruptions 250 periods			
OTHERS	MTBF	2575.6K hrs min. Telcordia SR-332 (Bellcore) ; 569.9K hrs min. MIL-HDBK-217F (25°C)			
	DIMENSION (L*W*H)	127*76.2*31mm or 5" * 3" *1.22" inch			
	PACKING	0.25Kg; 63pcs/17.3Kg/1.28CUFT			
NOTE	<p>1. All parameters NOT specially mentioned are measured at 230VAC input, rated load and 25°C of ambient temperature.</p> <p>2. Ripple & noise are measured at 20MHz of bandwidth by using a 12" twisted pair-wire terminated with a 0.1 μ F & 47 μ F parallel capacitor.</p> <p>3. Tolerance : includes set up tolerance, line regulation and load regulation.</p> <p>4. Touch current was measured from primary input to DC output.</p> <p>5. The ambient temperature derating of 3.5°C/1000m with fanless models and of 5°C/1000m with fan models for operating altitude higher than 2000m(6500ft).</p> <p>6. Length of set up time is measured at cold first start. Turning ON/OFF the power supply may lead to increase of the set up time.</p> <p>7. Heat Sink HS1,HS2,HS3 can not be shorted.</p> <p>8. The power supply is considered a component which will be installed into a final equipment. All the EMC tests are been executed by mounting the unit on a 360mm*360mm metal plate with 1mm of thickness. The final equipment must be re-confirmed that it still meets EMC directives. For guidance on how to perform these EMC tests, please refer to "EMI testing of component power supplies." (as available on https://www.meanwell.com/Upload/PDF/EMI_statement_en.pdf)</p> <p>※ Product Liability Disclaimer : For detailed information, please refer to https://www.meanwell.com/serviceDisclaimer.aspx</p>				

■ Block Diagram

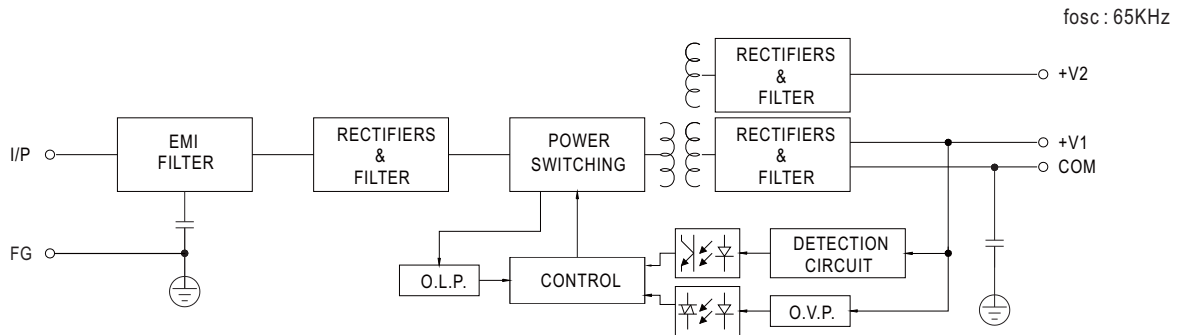

■ Derating Curve

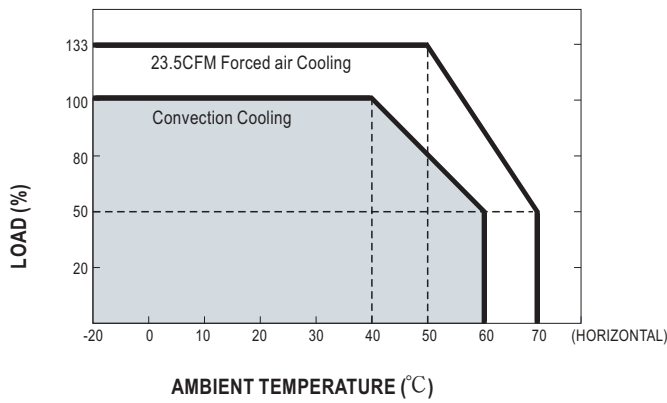

■ Output Derating VS Input Voltage

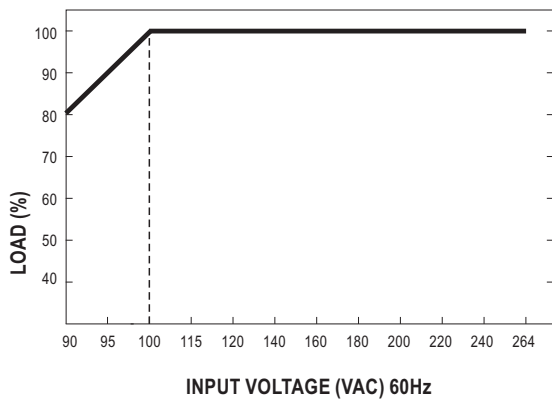

Mechanical Specification

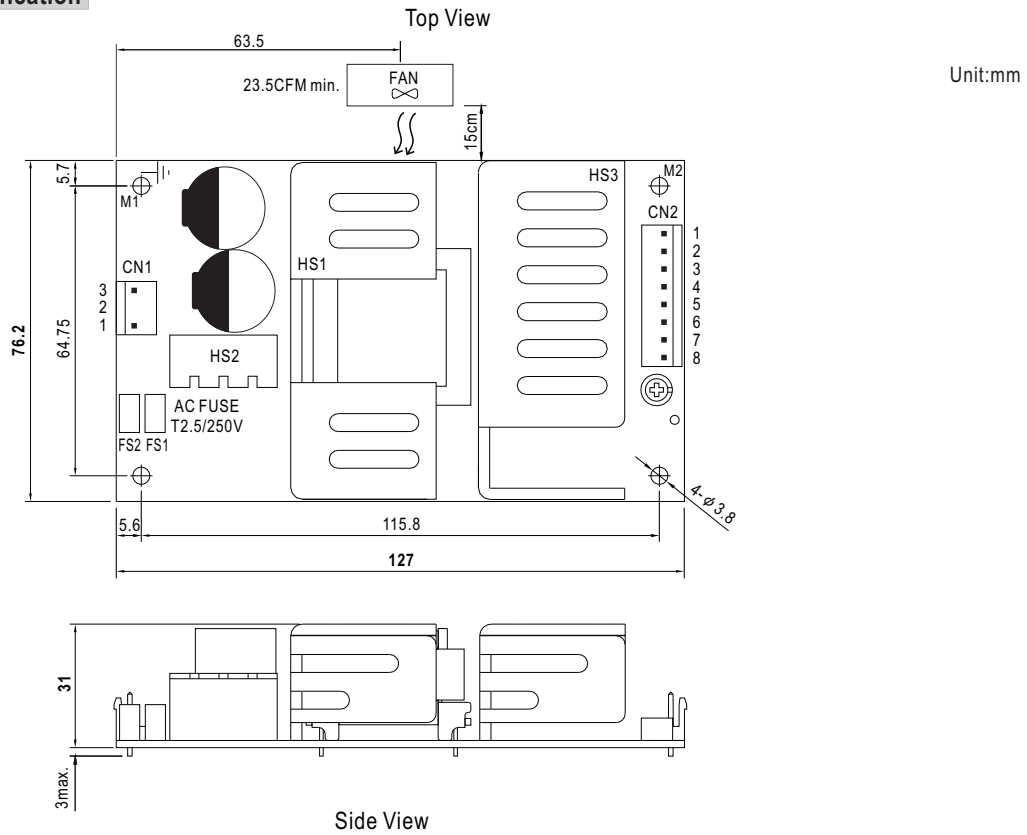

AC Input Connector (CN1) : JST B3P-VH or equivalent

Pin No.	Assignment	Mating Housing	Terminal
1	AC/N	JST VHR or equivalent	JST SVH-21T-P1.1 or equivalent
2	No Pin		
3	AC/L		

DC Output Connector (CN2) : JST B8P-VH or equivalent

Pin No.	Assignment	Mating Housing	Terminal
1,2	V1	JST VHR or equivalent	JST SVH-21T-P1.1 or equivalent
3,4,5	COM		
6,7	V2		
8	NC		

⊥ : Grounding Required





- 1.HS1,HS2,HS3 cannot be shorted.
- 2.M1 is safety ground. For better EMC performance,Please secure an electrical connection between M1,M2 and chassis grounding.

Installation Manual

Please refer to : <http://www.meanwell.com/manual.html>

Looking for pricing, stock, or lifecycle information?

Click below to explore more details on WIN SOURCE:

-  [View RPD-75B on WIN SOURCE](#)
-  [Mean Well Enterprises Co., Ltd. Information](#)

Optimize Your Supply Chain with WIN SOURCE Solutions

-  Global Sourcing Solution
-  Obsolete Management
-  Cost Control Management
-  Shortage Management
-  Alternative Solution
-  Excess Inventory Management