

Large Current External FET Controller T type Switching Regulators



Dual-output Step-up, Negative Voltage, Step-down Switching Regulators (Controller type)

BA9743AFV, BA9744FV, BA9741F, BA9741FS

No.11028EBT10

● Description

The BA9743AFV, BA9744FV, and BA9741F/FS are a 2-channel ICs, incorporating a switching regulator controller that uses a pulse width modulation. Both channels can be used for DC/DC converter operations including step up, step down, and inverting. Furthermore, since these ICs have significantly compact design, they are best suited for use as a power supply in miniature portable equipment.

● Features

- 1) Built-in timer-latch type short prevention circuit
- 2) Built-in malfunction prevention circuit during low input voltage
- 3) Built-in high-accuracy reference voltage output pin

BA9743AFV	2.505V±1%
BA9744FV	1.222V±1%
BA9741F/FS	2.5V±4%
- 4) Rest period adjustable over the whole range of duty ratio
- 5) A wide input range provided

BA9741F	VCC=3.6 to 35V
BA9741FS	VCC=3.6 to 35V
BA9743AFV	VCC=3.6 to 35V
BA9744FV	VCC=2.5 to 35V

● Applications

DC/DC converter in LCD, PC, AV, printer, DVD, projector, TV, Fax machine, Copying machine, Measuring equipment, etc

● Product lineup

	BA9743AFV	BA9744FV	BA9741F/FS
Power supply voltage	3.6V~35V	3.6V~35V	3.6V~35V
Output pin current	100mA	30mA	100mA
Output pin voltage	Max. 35V	Max. 35V	Max. 35V
Error amplifier input voltage	0.3V~1.6V	0.3V~1.5V	0.3V~1.6V
Timing capacitance	100p~15000pF	100p~15000pF	100p~15000pF
Timing resistance	5.1k~50kΩ	3k~15kΩ	5.1k~50kΩ
Oscillation frequency	10k~800kHz	10k~800kHz	10k~800kHz
Operating temperature	-40°C~+85°C	-40°C~+85°C	-40°C~+85°C
Package	SSOP-B16	SSOP-B16	SOP16/SSOP-A16

● Absolute maximum ratings

Item	Symbol	Limits				Unit
		BA9743AFV	BA9744FV	BA9741F	BA9741FS	
Power supply voltage	VCC	36	36	36		V
Power dissipation	Pd	450 ^{*3}	450 ^{*3}	500 ^{*1}	650 ^{*2}	mW
Operating temperature	Topr	-40~+85	-40~+85	-40~+85		°C
Storage temperature	Tstg	-55~+125	-55~+125	-55~+125		°C
Output pin current	Io	120 ^{*4}	60 ^{*4}	120 ^{*4}		mA
Output pin voltage	Vo	36	36	36		V

*1 Reduce by 4.5 mW/ °C over 25°C.
(when mounted on a PCB of 50mm×50mm×1.6 mm)

*2 Reduce by 5.0 mW/ °C over 25°C.
(when mounted on a PCB of 70mm×70mm×1.6 mm)

*3 Reduce by 6.5 mW/ °C over 25°C.
(when mounted on a PCB of 70mm×70mm×1.6 mm)

*4 Should not exceed Pd- or ASO-value.

● Electrical characteristics

◎ BA9743AFV

Electrical characteristics (Unless otherwise specified, Ta=25°C and Vcc=6V)

Item	Symbol	Limits			Unit	Conditions
		Min.	Typ.	Max.		
[Reference voltage section]						
Output voltage	VREF	2.48	2.505	2.53	V	IREF=1mA
Input stability	VdLI	—	1	10	mV	VCC=3.6~35V
Load stability	VdLO	—	1	10	mV	IREF=0~5mA
[Triangular wave oscillator section]						
Oscillation frequency	FOSC	320	400	480	KHz	RRT=10kΩ, CCT=220pF
Frequency variation	FDV	—	1	—	%	VCC=3.6~35V
[Protection circuit section]						
Threshold voltage	VIT	1.48	1.64	1.80	V	
Standby voltage	VSTB	—	50	100	mV	No pull-up
Latch voltage	VLT	—	30	100	mV	No pull-up
Source current	ISCP	1.5	2.5	3.5	μA	
Comparator threshold voltage	VCT	0.95	1.05	1.15	V	5pin, 12pin
[Rest period adjustment circuit section]						
Input threshold voltage (fosc=10kHz)	Vt0	1.87	1.97	2.07	V	Duty cycle = 0%
	Vt100	1.38	1.48	1.58	V	Duty cycle = 100%
ON duty cycle	DON	45	55	65	%	VREF is divided by 13kΩ and 27kΩ resistors.
Input bias current	IBDT	—	0.1	1	μA	DTC=2.0V
Latch mode source current	IDT	200	560	—	μA	DTC=0V
Latch input voltage	VDT	2.28	2.48	—	V	IDT=40 μA
[Low-input-voltage malfunction prevention circuit section]						
Threshold voltage	VUT	2.23	2.53	2.83	V	
[Error amplifier section]						
Input offset voltage	VIO	—	—	6	mV	
Input offset current	IIO	—	—	30	nA	
Input bias current	IIB	—	15	100	nA	
Open loop gain	AV	70	85	—	dB	
Common-mode input voltage	VCM	0.3	—	1.6	V	VCC=3.6~35V
Common-mode rejection ratio	CMRR	60	80	—	dB	
Maximum output voltage	VOM	2.3	2.5	—	V	
Minimum output current	VOL	—	0.7	0.9	V	
Output sink current	IOI	3	20	—	mA	FB=1.25V
Output source current	IOO	45	75	—	μA	FB=1.25V
[PWM comparator section]						
Input threshold voltage (fosc=10kHz)	Vt0	1.87	1.97	2.07	V	Duty cycle = 0%
	Vt100	1.38	1.48	1.58	V	Duty cycle = 100%
[Output section]						
Saturation voltage	VSAT	—	0.8	1.2	V	Io=75mA
Leak current	I LEAK	—	—	5	μA	Vo=35V
[Total device]						
Standby current	ICCS	—	1.3	1.8	mA	When output is OFF
Average current dissipation	ICCA	—	1.6	2.3	mA	RRT=10kΩ

◎ This IC is not designed to be radiation-resistant.

◎BA9744FV

Electrical characteristics (Unless otherwise specified, Ta=25°C and Vcc=3V)

Item	Symbol	Limits			Unit	Conditions
		Min.	Typ.	Max.		
[Reference voltage section]						
Output voltage	VREF	1.210	1.222	1.234	V	IREF=1mA
Input stability	VDLI	—	3	10	mV	VCC=2.5~35V
Load stability	VULO	—	1	10	mV	IREF=0~5mA
[Triangular wave oscillator section]						
Oscillation frequency	FOSC	320	400	480	KHz	RRT=5.1k,CCT=220pF
Frequency variation	F _{OV}	—	1	—	%	Vcc=2.5~35V
[Protection circuit section]						
Threshold voltage	V _{IT}	0.98	1.18	1.38	V	
Standby voltage	V _{STB}	—	50	100	mV	No pull-up
Latch voltage	V _{LT}	—	23	100	mV	No pull-up
Source current	I _{SCP}	1.0	2.0	3.0	μA	
Comparator threshold voltage	V _{CT}	0.15	0.25	0.35	V	5pin, 12pin
[Rest period adjustment circuit section]						
Input threshold voltage (fosc=10kHz)	V _{t0}	0.96	1.01	1.06	V	Duty cycle=0%
	V _{t100}	0.46	0.49	0.52	V	Duty cycle=100%
ON duty cycle	D _{ON}	45	55	65	%	
Input bias current	I _{BDT}	—	0.1	1	μA	DTC=2V
Latch mode source current	I _{DT}	390	780	—	μA	DTC=0V
Latch input voltage	V _{DT}	Vcc-0.5	Vcc-0.4	—	V	IDT=40μA
[Low-input-voltage malfunction prevention circuit section]						
Threshold voltage	V _{UT}	1.6	1.9	2.2	V	
[Error amplifier section]						
Input offset voltage	V _{I0}	—	0	6	mV	
Input offset current	I _{I0}	—	0	30	nA	
Input bias current	I _{IB}	—	15	100	nA	
Open loop gain	A _V	65	85	—	dB	
Common-mode input voltage	V _{CM}	0.3	—	1.5	V	VCC=2.5~35V
Common-mode rejection ratio	CMRR	60	80	—	dB	
Maximum output voltage	V _{OM}	1.5	2.0	—	V	
Minimum output current	V _{OL}	—	0.1	0.3	V	
Output sink current	I _{O1}	1	2.1	—	mA	FB=0.75V
Output source current	I _{O0}	50	70	90	μA	FB=0.75V
[PWM comparator section]						
Input threshold voltage (fosc=10kHz)	V _{t0}	0.96	1.01	1.06	V	Duty cycle=0%
	V _{t100}	0.46	0.49	0.52	V	Duty cycle=100%
[Output section]						
Saturation voltage 1	V _{SAT}	—	0.06	0.3	V	I _o =10mA
Saturation voltage 2	V _{SAT}	—	0.15	0.4	V	I _o =30mA
Leak current	I _{LEAK}	—	0	5	μA	V _o =35V
[Total device]						
Standby current	I _{CCS}	—	3.6	5.0	mA	When output is OFF
Average current dissipation	I _{CCA}	—	3.9	5.6	mA	RRT=5.1kΩ

◎ This IC is not designed to be radiation-resistant.

◎BA9741F/BA9741FS

Electrical characteristics (Unless otherwise specified, Ta=25°C and Vcc=3V)

Item	Symbol	Limits			Unit	Conditions
		Min.	Typ.	Max.		
[Reference voltage section]						
Output voltage	VREF	2.4	2.5	2.6	V	IREF=1mA
Input stability	VDLI	—	1	10	mV	VCC=3.6~35V
Load stability	VDLO	—	1	10	mV	IREF=0~5mA
[Triangular wave oscillator section]						
Oscillation frequency	FOSC	320	400	480	KHz	RRT=10kΩ,CCT=220pF
Frequency variation	Fdv	—	1	—	%	VCC=3.6~35V
[Protection circuit section]						
Threshold voltage	VIT	1.48	1.64	1.80	V	
Standby voltage	VSTB	—	50	100	mV	No pull-up
Latch voltage	VLT	—	30	100	mV	No pull-up
Source current	ISCP	1.5	2.5	3.5	μA	
Comparator threshold voltage	VCT	0.9	1.05	1.2	V	5pin, 12pin
[Rest period adjustment circuit section]						
Input threshold voltage (fosc=10kHz)	Vt0	1.79	1.97	2.15	V	Duty cycle=0%
	Vt100	1.32	1.48	1.64	V	Duty cycle=100%
ON duty cycle	DON	45	55	65	%	VREF is divided by 13kΩ and 27kΩ resistors.
Input bias current	IBDT	—	0.1	1	μA	DTC=2.0V
Latch mode source current	IDT	200	560	—	μA	DTC=0V
Latch input voltage	VDT	2.28	2.48	—	V	IDT=40 μA
[Low-input-voltage malfunction prevention circuit section]						
Threshold voltage	VUT	—	2.53	—	V	
[Error amplifier section]						
Input offset voltage	VIO	—	—	6	mV	
Input offset current	IIO	—	—	30	nA	
Input bias current	IIB	—	15	100	nA	
Open loop gain	AV	70	85	—	dB	
Common-mode input voltage	VCM	0.3	—	1.6	V	VCC=3.6~35V
Common-mode rejection ratio	CMRR	60	80	—	dB	
Maximum output voltage	VOM	2.3	2.5	—	V	
Minimum output current	VOL	—	0.7	0.9	V	
Output sink current	I01	3	20	—	mA	FB=1.25V
Output source current	I00	45	75	—	μA	FB=1.25V
[PWM comparator section]						
Input threshold voltage (fosc=10kHz)	Vt0	1.79	1.97	2.15	V	Duty cycle=0%
	Vt100	1.32	1.48	1.64	V	Duty cycle=100%
[Output section]						
Saturation voltage	VSAT	—	0.8	1.2	V	Io=75mA
Leak current	I _{LEAK}	—	—	5	μA	Vo=35V
[Total device]						
Standby current	ICCS	—	1.3	1.8	mA	When output is OFF
Average current dissipation	ICCA	—	1.6	2.3	mA	RRT=10kΩ

◎ This IC is not designed to be radiation-resistant.

● Reference data

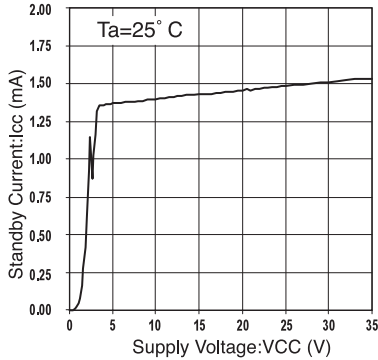

Fig. 1 Standby current vs. Power supply voltage (BA9741F/FS/BA9743AFV)

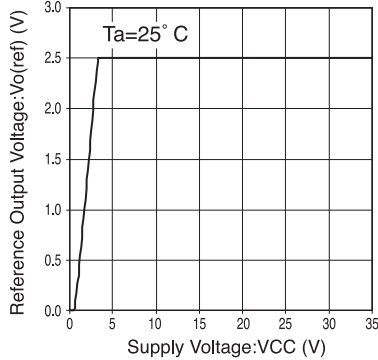

Fig. 2 Reference output voltage vs. Power supply voltage (BA9741F/FS/BA9743AFV)

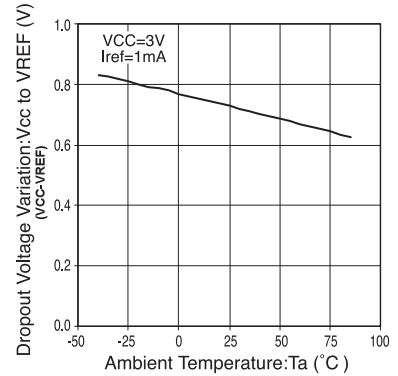

Fig. 3 Dropout voltage vs. Ambient temperature (BA9741F/FS/BA9743AFV)

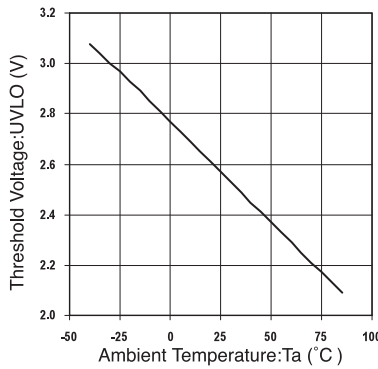

Fig. 4 UVLO operating voltage vs. Ambient temperature (BA9741F/FS/BA9743AFV)

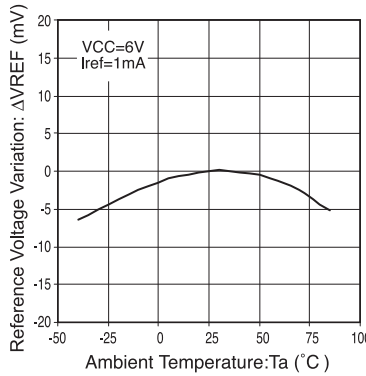

Fig. 5 Reference voltage vs. Ambient temperature (BA9741F/FS/BA9743AFV)

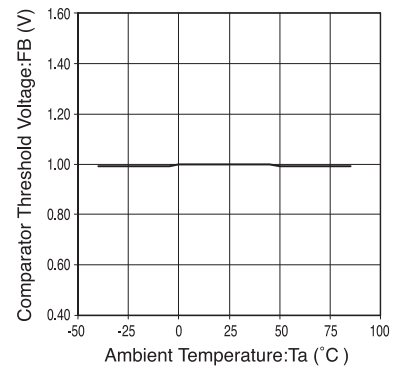

Fig. 6 Protection circuit characteristics (BA9741F/FS/BA9743AFV)

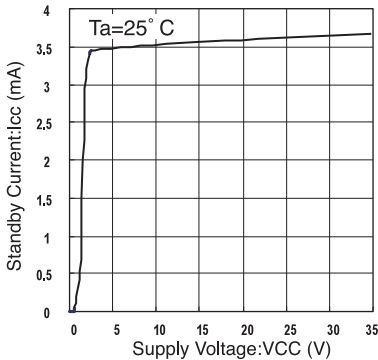

Fig. 7 Standby current vs. Power supply voltage (BA9744FV)

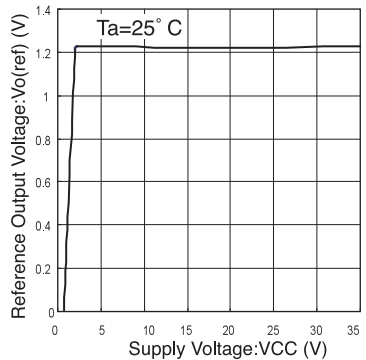

Fig. 8 Reference output voltage vs. Power supply voltage (BA9744FV)

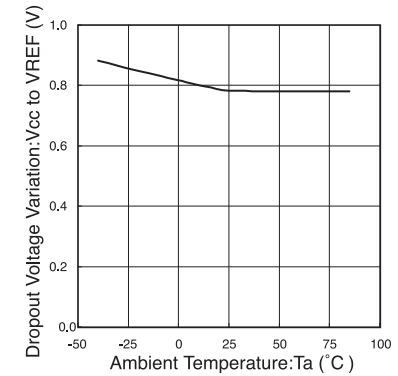

Fig. 9 Dropout voltage vs. Ambient temperature (BA9744FV)

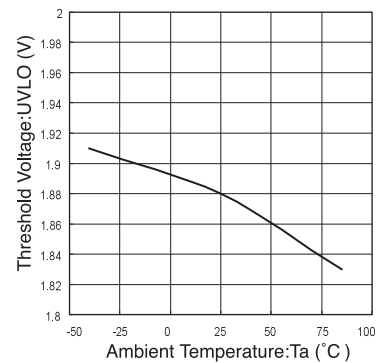

Fig. 10 UVLO operating voltage vs. Ambient temperature (BA9744FV)

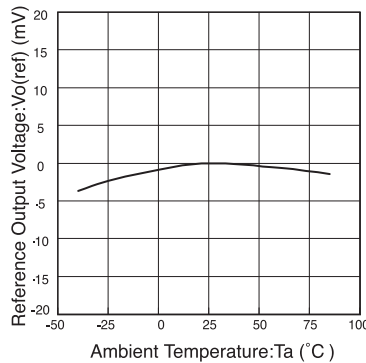

Fig. 11 Reference voltage vs. Ambient temperature (BA9744FV)

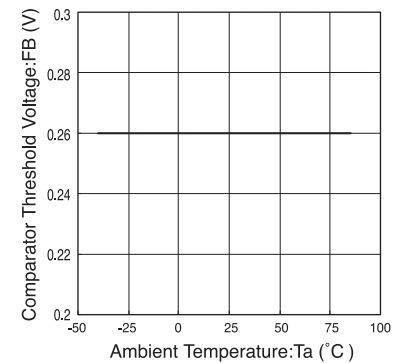

Fig. 12 Protection circuit characteristics (BA9744FV)

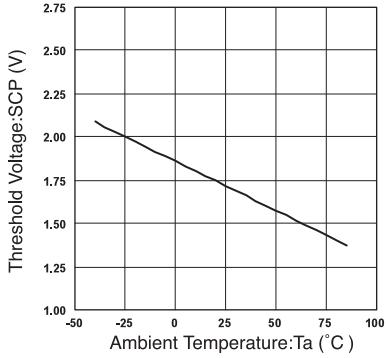

Fig. 13 Protection circuit characteristics (BA9741F/FS/BA9743AFV)

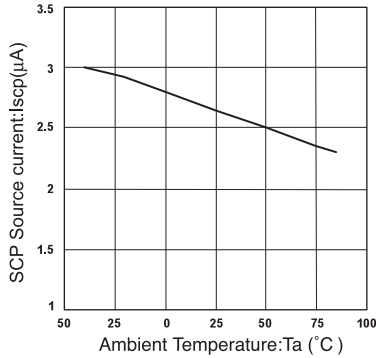

Fig. 14 Protection circuit characteristics (BA9741F/FS/BA9743AFV)

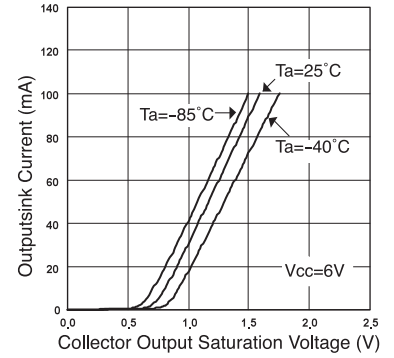

Fig. 15 Output current vs. Collector saturation voltage (BA9741F/FS/BA9743AFV)

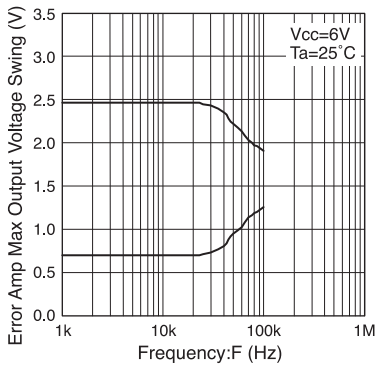

Fig. 16 Error amp. Output voltage vs. Amplitude frequency (BA9741F/FS/BA9743AFV)

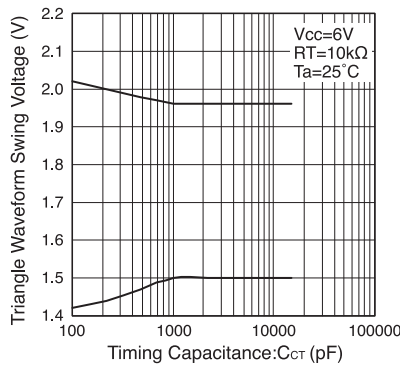

Fig. 17 Triangular wave amplitude vs. Timing capacitor (BA9741F/FS/BA9743AFV)

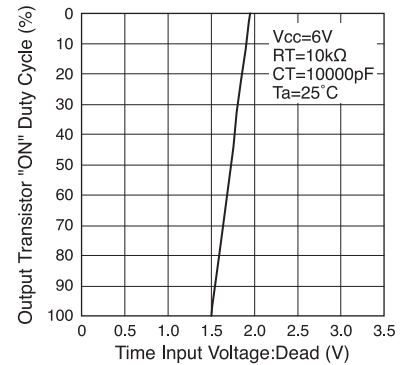

Fig. 18 Output transistor ON duty vs. Dead time voltage (BA9741F/FS/BA9743AFV)

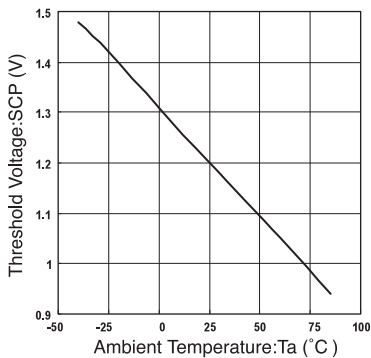

Fig. 19 Protection circuit characteristics (BA9744FV)

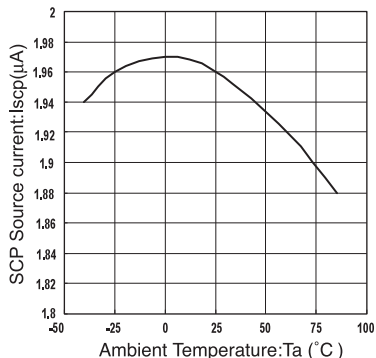

Fig. 20 Protection circuit characteristics (BA9744FV)

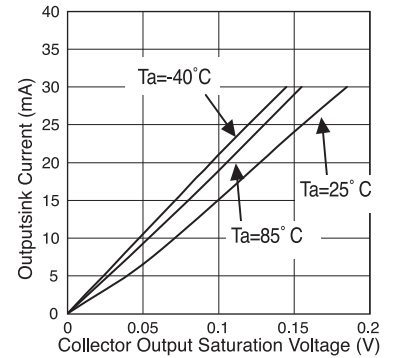

Fig. 21 Output current vs. Collector saturation voltage (BA9744FV)

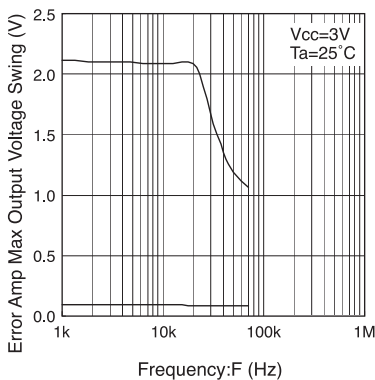

Fig. 22 Error amp. Output voltage vs. Amplitude frequency (BA9744FV)

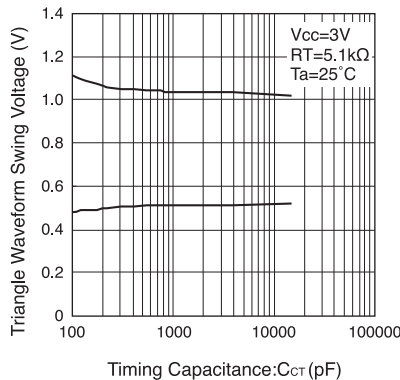

Fig. 23 Triangular wave amplitude vs. Timing capacitor (BA9744FV)

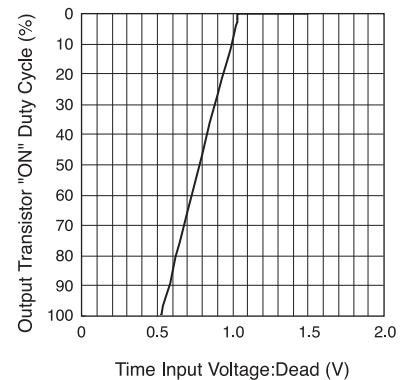

Fig. 24 Output transistor ON duty vs. Dead time voltage (BA9744FV)

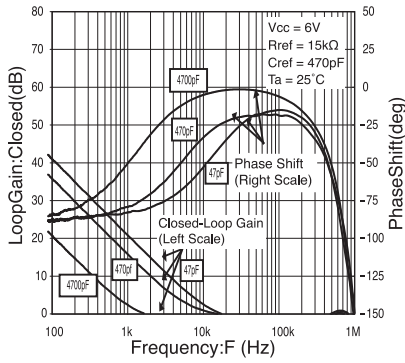

Fig. 25 Closed loop gain vs. Phase frequency (BA9741F/FS/BA9743AFV)

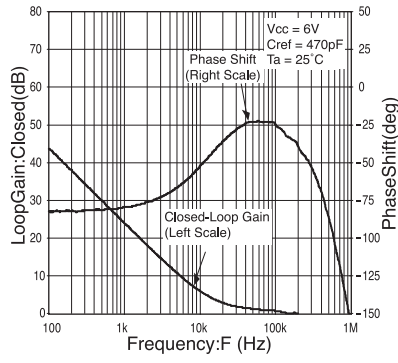

Fig. 26 Closed loop gain vs. Phase frequency (BA9741F/FS/BA9743AFV)

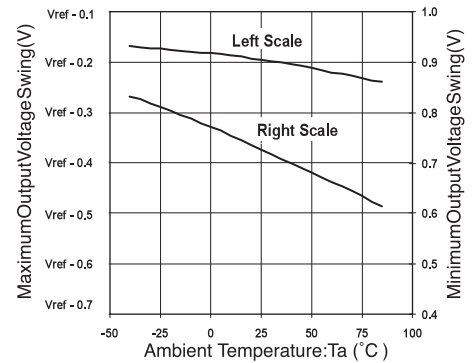

Fig. 27 Maximum output voltage amplitude vs. Ambient temperature (BA9741F/FS/BA9743AFV)

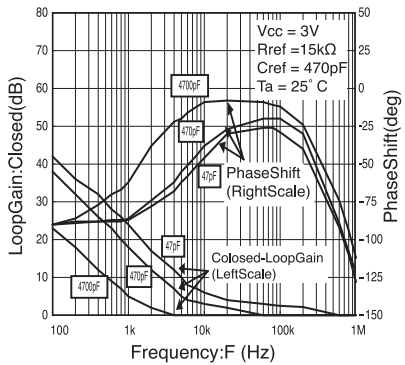

Fig. 28 Closed loop gain vs. Phase frequency (BA9744FV)

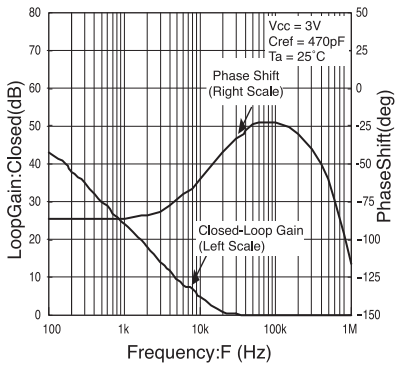

Fig. 29 Closed loop gain vs. Phase frequency (BA9744FV)

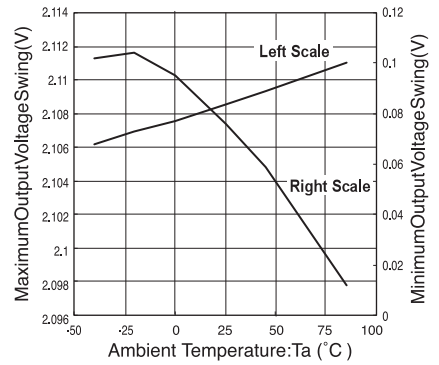

Fig. 30 Maximum output voltage amplitude vs. Ambient temperature (BA9744FV)

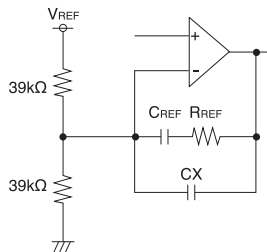

Fig.25 Test Circuit

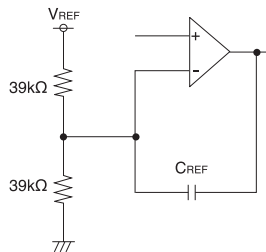
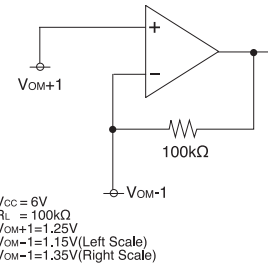

Fig.26 Test Circuit



Vcc = 6V
Rl = 100kΩ
Vom+1=1.25V
Vom-1=1.15V(Left Scale)
Vom-1=1.35V(Right Scale)

Fig.27 Test Circuit

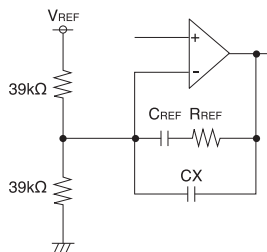

Fig.28 Test Circuit

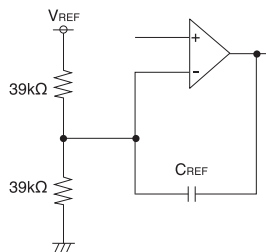
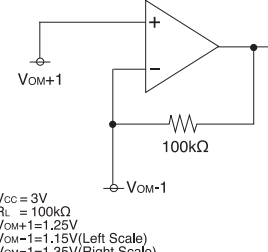

Fig.29 Test Circuit



Vcc = 3V
Rl = 100kΩ
Vom+1=1.25V
Vom-1=1.15V(Left Scale)
Vom-1=1.35V(Right Scale)

Fig.30 Test Circuit

● Block diagram/Pin assignment

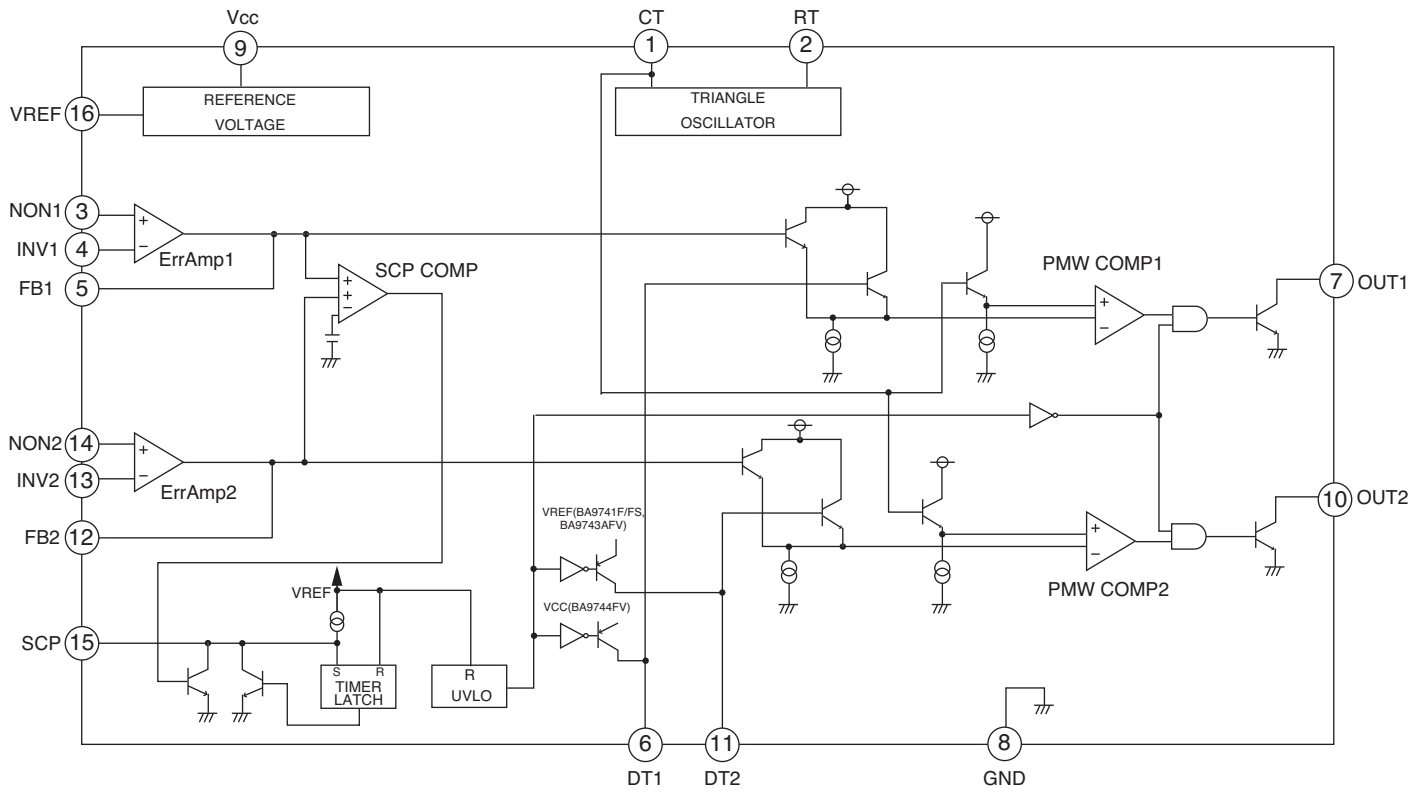
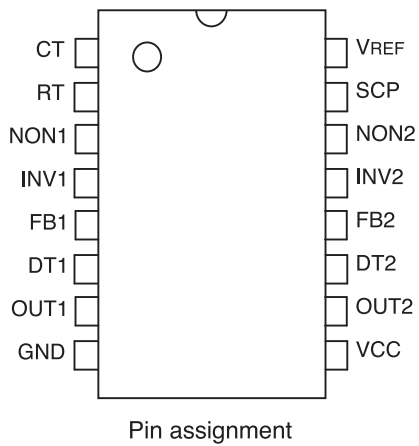

Fig.31



PIN No.	Pin name	Function
1	CT	External timing capacitance
2	RT	External timing resistance
3	NON 1	Positive input for error amplifier 1
4	INV 1	Negative input for error amplifier 1
5	FB 1	Output for error amplifier 1
6	DT 1	Output 1 dead time/soft start setting
7	OUT 1	Output 1
8	GND	GROUND
9	VCC	Power supply
10	OUT 2	Output 2
11	DT 2	Output 2 dead time / soft start setting
12	FB 2	Output for error amplifier 2
13	INV 2	Negative input for error amplifier 2
14	NON 2	Positive input for error amplifier 2
15	SCP	Timer latch setting
16	VREF	Reference voltage output

● Description of operations

1) REFERENE VOLTAGE (Reference voltage section)

From the power supply voltage input through the VCC pin (pin 9), a reference voltage, which is stabilized at the VREF, is supplied as the operating power supply voltage for the internal circuits of the IC and, at the same time, output through the VREF pin (pin 16).

2) ErrAmp1/2 (Error amplifiers)

In the case of step up / step down application, the non-inverting input pins NON1 and NON2 are used to detect the output voltage by feeding back the voltage from the final output stage (i.e., loading side). R1 and R2, which are connected to these pins, are resistors used to control the output voltage. The voltage applied to the inverting input pins INV1 and INV2 as a reference input voltage of the error amplifiers themselves, should be the voltage obtained by dividing the reference voltage (VREF) by resistance.

$$\left(V_{REF} \frac{R4}{R3 + R4} \right)$$

Furthermore, the resistor Rf and the capacitor Cf, connected between the FB1/2 (Pin 5/12) and INV1/2 (Pin 6/11), are used for feedback of the error amplifier, enabling settings of any desired level of loop gain.

It is recommended to provide AC feedback using the capacitor Cf and the resistor Rf as the feedback for the error amplifier. The amplifier output pins FB1 and FB2 are connected to the PWM and SCP comp., and used as the non-inverting input pins. The output voltage (Vo) setting is shown below:

$$V_o = \frac{R1 + R2}{R2} \times \left(V_{REF} \frac{R4}{R3 + R4} \right)$$

Since the input range VOM of the NON and INV pins is 0.3V to 1.6V (for BA9741F/FS / BA9743AFV) or 0.3V to 1.5V (for BA9744FV), it is recommended to set the range to approximately VREF/2, i.e., as shown below.

$$\left. \begin{aligned} V_{REF} \frac{R4}{R3 + R4} &\cong 1.25V \text{ (BA9741F/FS/BA9743AFV)} \\ &\cong 0.6V \text{ (BA9744FV)} \end{aligned} \right\}$$

3) Triangle Oscillator (Triangular wave oscillator section)

Used to generate a triangular waveform to be input in the PWM comp. 1/2.

The oscillator circuit charges/discharges the timing capacitor CCT that is connected between the CT pin (pin 1) and the GND at a constant current, set with resistor RRT that is connected between the RT pin (pin 2) and the GND. The triangular waveform is obtained through detecting and resetting this charged/discharged voltage.

The oscillation frequency is given through the external CCT and RRT pins by the formula shown below (BA9741F/FS/BA9743AFV):

$$f_{osc} \cong \frac{V_{RT}}{2 \cdot C_{CT} \cdot R_{RT} \cdot \Delta V_{osc}} \cong \frac{1}{(C_{CT} \cdot R_{RT})}$$

V_{RT}: RT pin voltage 1V_{typ}
 ΔV_{osc}: Triangular wave amplitude voltage=V_{t0}-V_{t100}=0.49V_{typ}

(BA9744FV)

$$f_{osc} \cong \frac{V_{RT}}{2 \cdot C_{CT} \cdot R_{RT} \cdot \Delta V_{osc}} \cong \frac{1}{(C_{CT} \cdot R_{RT})}$$

V_{RT}: RT pin voltage 0.6V_{typ}
 ΔV_{osc}: Triangular wave amplitude voltage=V_{t0}-V_{t100}=0.52V_{typ}

However, at high frequencies, since delay in the internal circuit results in an error against the formula, set oscillation frequency according to the fosc- RRT graph shown below:

Furthermore, this triangular wave can be output through the CT pin (pin 1).

Range of standard external CCT and RRT pins

RRT: 5.1kΩ at minimum to 50kΩ at maximum (BA9741F/FS / BA9743AFV) or 3kΩ at minimum to 15kΩ at maximum (BA9744FV)
 CCT: 100pF at minimum to 15000pF at maximum

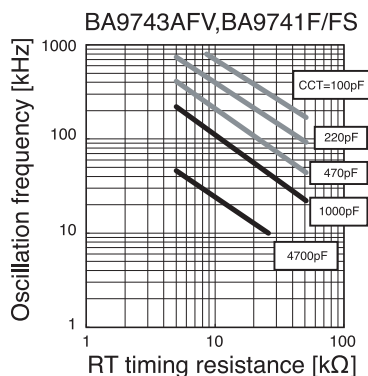

Fig.33

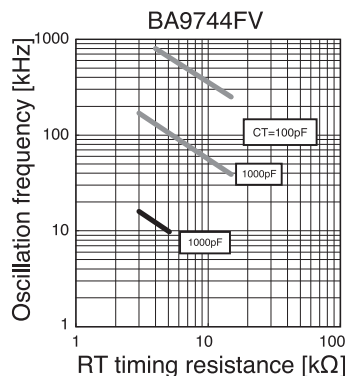

Fig.34

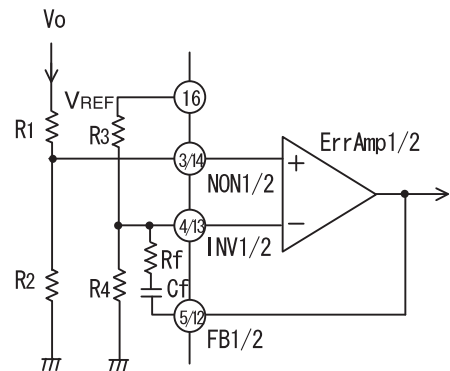

Fig.32

4) SCP Comp (Timer-latch type short-circuit prevention circuit)

When the output voltage malfunctions because of a short circuit, this function is used to turn OFF the output transistor forcedly, in order to protect the system. If the output voltage drops in reaction to the set voltage level, an error will be amplified through the Err Amp and the voltage at the FB1/FB2 pins will reach the low voltage side. If SCP Comp sets the voltage below the threshold level for either the FB1 or FB2, (i.e., 1.05Vtyp for the BA9741F/FS / BA9743AFV or 0.25Vtyp for the BA9744FV), the short prevention circuit will be activated to start the charging of the capacitor of SCP pin. When $V_{IT}=1.64V_{typ}$ for the BA9741F/FS / BA9743AFV or $V_{IT}=1.18V_{typ}$ for the BA9744FV is achieved, the output transistor will turn OFF.

The time is set by the capacitor (Cscp) connected to the SCP (pin 15).
The time TSCP is obtained by the formula shown below:

$$SCPT = \frac{V_{IT} + V_{STB}}{I_{SCP}} \cdot C_{scp}$$

For example, in the case of the BA9743AFV, assuming that $C_{SCP}=0.1\mu F$, $V_{IT}=1.64V$, $V_{STB}=0.05V$ and $I_{SCP}=2.5\mu A$.

$$SCPT = \frac{1.64 - 0.05}{2.5\mu} \times 0.1\mu = 63.6mS$$

In order to stop the function of the short prevention circuit, short-circuit the SCP pin to GND

5) PWM Comp 1/2 DEAD TIME (Rest period adjustment circuit / Dead time)

This function can be set by dividing the resistance of DT1 and DT2 pins (pins 6 and 11) between VREF and GND. With PWM Comp, comparing the dead time voltage input and the error voltage from the Err Amp with the triangular wave, the output drive transistors are turned ON/OFF.

When Dead time voltage > Error voltage, the output duty is determined by the dead time voltage.
The dead time voltage VDT is obtained by the expression shown below

$$V_D = V_{REF} \cdot \frac{R_2}{R_1 + R_2}$$

(BA9741F/FS/BA9743AFV)

When $V_{DT}=1.48V_{typ}$: Duty 100%
When $V_{DT}=1.97V_{typ}$: Duty 0%
(Provided, however, that $f_{osc}=10kHz$)

(BA9744FV)

When $V_{DT}=0.49V_{typ}$: Duty 100%
When $V_{DT}=1.01V_{typ}$: Duty 0%
(Provided, however, that $f_{osc}=10kHz$)

Note: If the oscillation frequency is at a high level, the upper/lower limits (V_{t0}/V_{t100}) of the triangular wave will be shifted in the direction in which the amplitude is developed.

6) PWM Comp 1/2 SS (Soft start function)

By connecting the resistors R1 and R2, and the capacitor CDT to DT pins (pins 6 and 11), as shown in figure on the right, the soft start function is enabled.

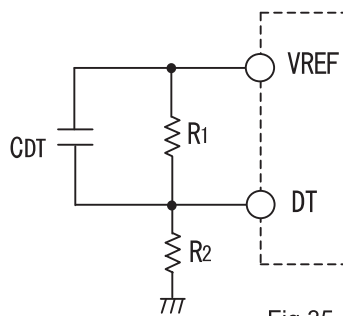
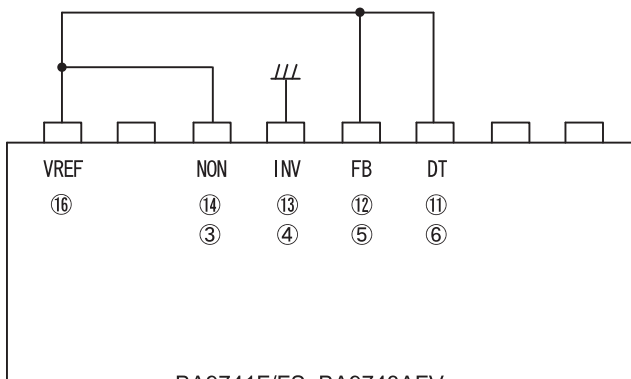
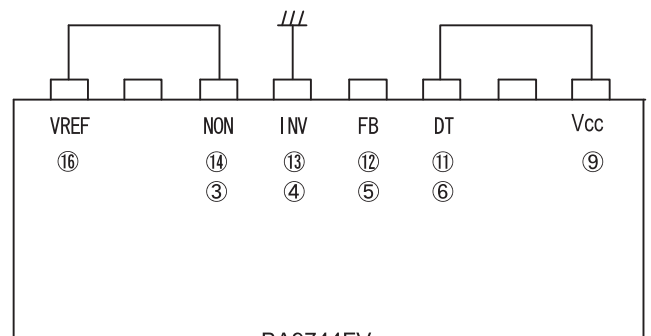

Fig.35

7) Handling of pins of unused channel



BA9741F/FS, BA9743AFV
Fig.36



BA9744FV
Fig.37

If channel 1 is only used, the unused channel should be handled as shown above.

● Typical application circuit

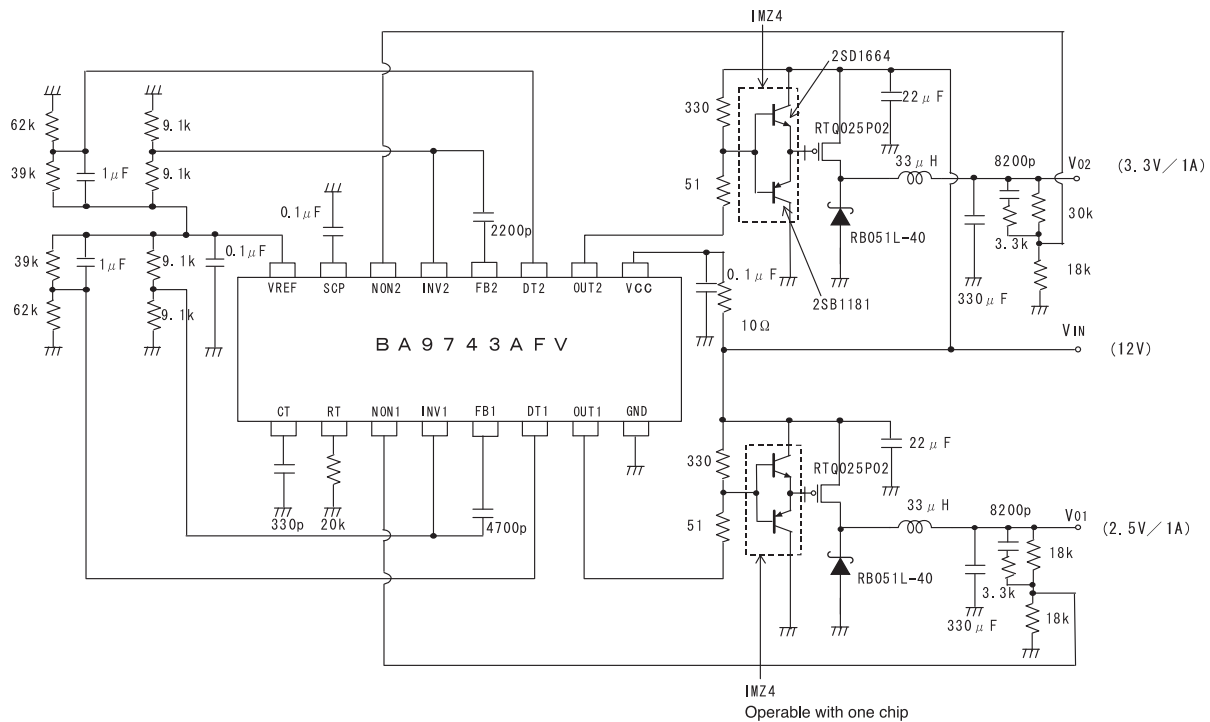

Fig. 38

1) Setting the coil (L) and capacitor (Co) of output section

The settings of the coil and capacitor with the step down application are made as shown below.:

<Setting of L value>

If the load current increases, a current will continuously flow through the coil, thus holding the relational formulas (1).

$$L = \frac{T_s}{\Delta I_L} \times \frac{(V_{IN} - V_o) \times V_o}{V_{IN}} \quad (1)$$

V_{IN} : Input voltage
 T_s : $1/(\text{Oscillation frequency})$
 ΔI_L : Ripple current of coil

ΔI_L should typically be set to 30% or less than the maximum output current (I_{omax}).

Increasing the L value decreases the ripple current (ΔI_L). Generally, the larger the L value, the smaller the allowable current of coil. Consequently, since the ripple current exceeding the allowable current results in variations in the L value, check for the appropriate current value with the coil manufacturer.

<Setting of output capacitor Co>

The output capacitor Co should be selected according to the ESR (Electric Series Resistance) characteristics of the capacitor.

For the output ripple voltage (ΔV_o), the following formula is held according to the ESR of the output capacitor:

$$\Delta V_o \cong \Delta I_L \times ESR$$

ESR: Series resistance of the output capacitor Co

A ripple component, due to the output capacitor, is significantly small in comparison to that due to the ESR.

Even though the Co value should meet the condition of $1/(3 \cdot T_s) > 1/2\pi (L \times Co)^{1/2}$, it is recommended to use a capacitor with a high enough capacitance value, to meet the ESR condition.

<Switching element>

The switching element should be determined according to the peak current. The peak current $I_{sw}(\text{peak})$ flowing through the switching element is equal to that flowing through the coil, thus holding the formula shown below:

$$I_{sw}(\text{peak}) = I_o + \Delta I_L/2$$

Select a switching element that has an allowable current that is twice (or more) as large as the peak current obtained by the formula shown above. Furthermore, with consideration given to overcurrent caused by output short-circuited, provide an application for overcurrent protection, wherever necessary.

2) Typical standby circuit

The typical standby circuit is shown in the dotted frame below.

An additional switch is typically mounted between the power supply (VIN) and the IC power supply pin (VCC).

Controlling the switch so that Tr1 and Tr2 will turn OFF when the standby circuit is activated, reduces current flow in standby mode.

It is recommended to set the Rvcc to 10Ω and the Cvcc to 0.1μF.
 Set Rvcc and the Cvcc within the range of 1 to 100Ω and 0.1 to 100μF.
 Providing additional Rvcc and Cvcc helps to cut noises from the VIN line.

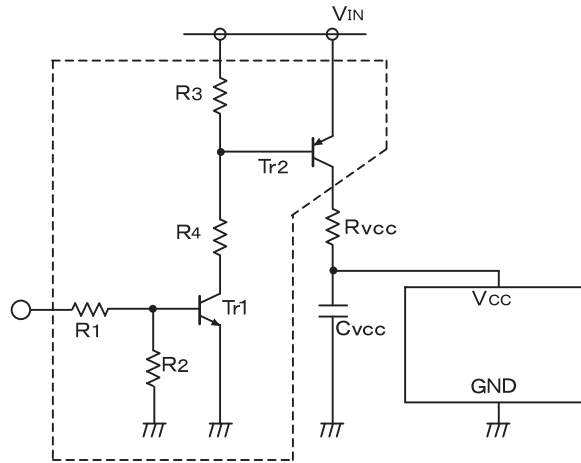

Typical standby circuit Fig.39

3) Typical overcurrent protection circuit

Insert sensing resistors between FET source and VIN of the channel P of output section, as shown in figure on the right, to detect an overcurrent.

$$I_{max} = \frac{V_f}{R_S}$$

If any sensing resistor detects an overcurrent, the composite digital transistor, shown in figure on the right, will turn ON to set the DT pin to "H", thus turning OFF the output.

Once the DT pin has been set to "H", soft start (restart) mode is enabled through an external capacitor. Furthermore, if an overcurrent flows through the circuit, latching will be enabled through connecting the digital transistor PNP collector to the SCP pin (pin 15).

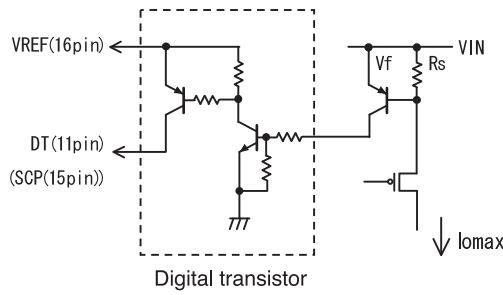

Digital transistor
 Typical overcurrent protection circuit Fig.40

4) Typical application of Master/Slave operation circuit

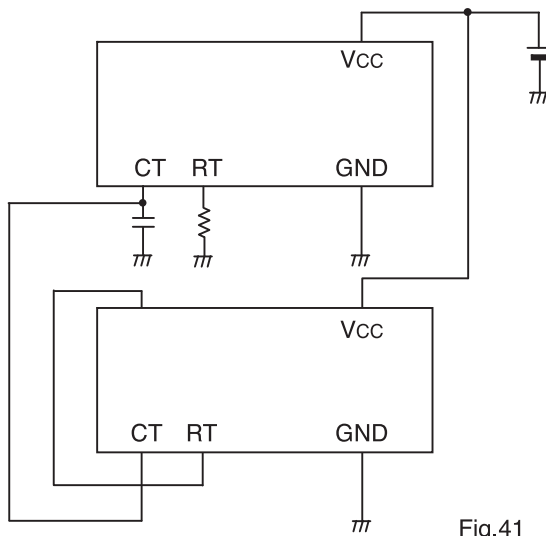

Fig.41

Caution:

The oscillation frequency should be determined according to capacitors and resistors connected to the CT pin (pin 1) and RT pin (pin 2) on the master IC.

However, increasing the number of slave ICs, increases the parasitic capacitance of these ICs in contact with the CT pin, resulting in a drift of oscillation frequency.

● Equivalent circuit

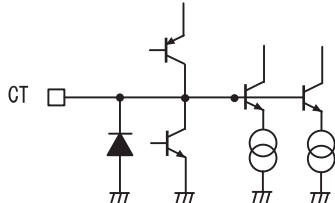
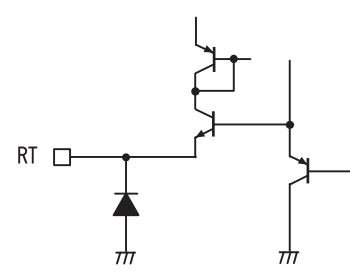
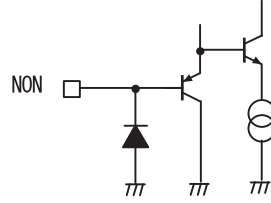
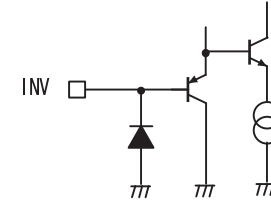
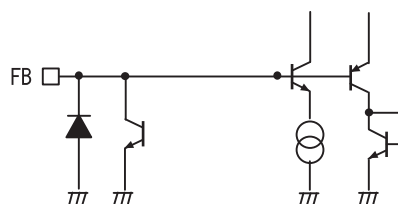
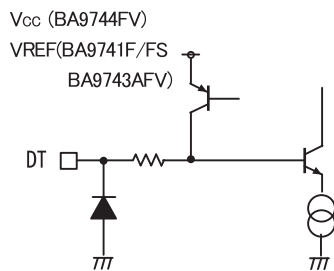
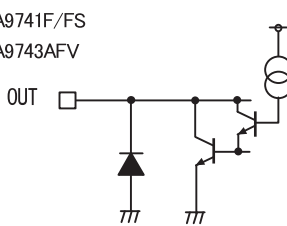
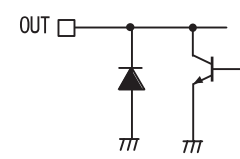
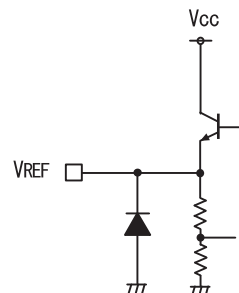
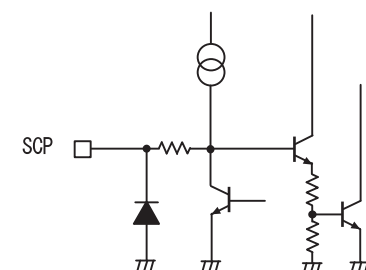
<p>1PIN(CT)</p> 	<p>2PIN(RT)</p> 
<p>3, 14PIN(NON1, NON2)</p> 	<p>4, 13PIN(INV1, INV2)</p> 
<p>5, 12PIN(FB1, FB2)</p> 	<p>6, 11PIN(DT1, DT2)</p> <p>Vcc (BA9744FV) VREF(BA9741F/FS BA9743AFV)</p> 
<p>7, 10PIN(OUT1, OUT2)</p> <p>BA9741F/FS BA9743AFV</p> 	<p>7, 10PIN(OUT1, OUT2)</p> <p>BA9744FV</p> 
<p>16PIN(VREF)</p> 	<p>15PIN(SCP)</p> 

● Equivalent circuit

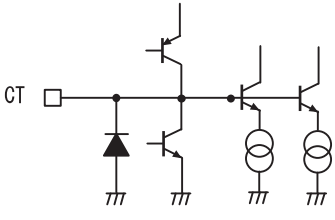
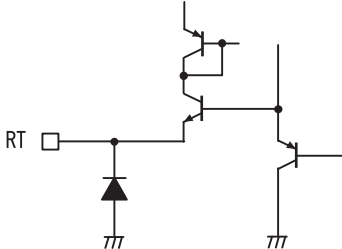
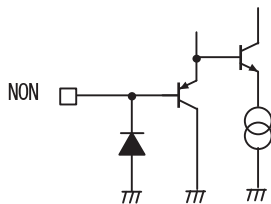
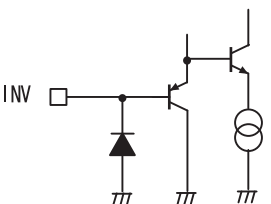
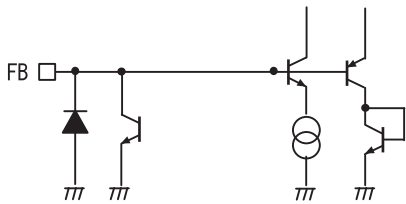
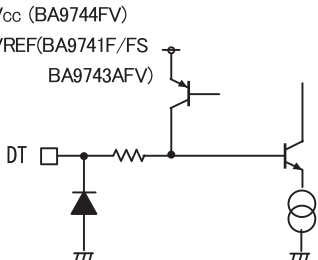
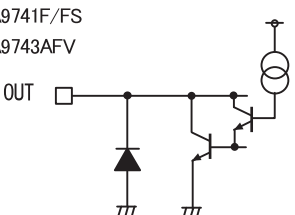
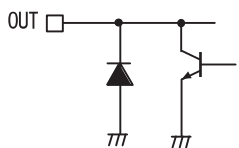
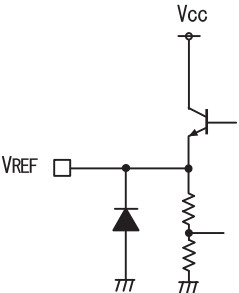
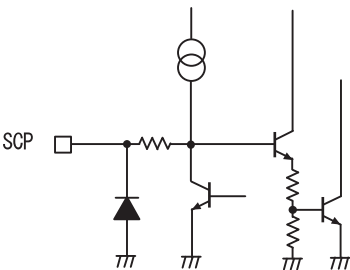
<p>1PIN (CT)</p> 	<p>2PIN (RT)</p> 
<p>3, 14PIN (NON1, NON2)</p> 	<p>4, 13PIN (INV1, INV2)</p> 
<p>5, 12PIN (FB1, FB2)</p> 	<p>6, 11PIN (DT1, DT2)</p> <p>V_{CC} (BA9744FV) V_{REF}(BA9741F/FS BA9743AFV)</p> 
<p>7, 10PIN (OUT1, OUT2)</p> <p>BA9741F/FS BA9743AFV</p> 	<p>7, 10PIN (OUT1, OUT2)</p> <p>BA9744FV</p> 
<p>16PIN (VREF)</p> <p>V_{CC}</p> 	<p>15PIN (SCP)</p> 

● Heat dissipation characteristics

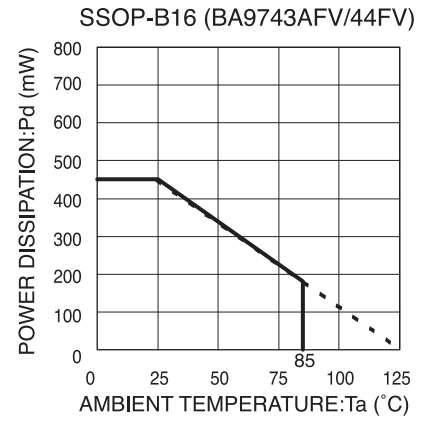
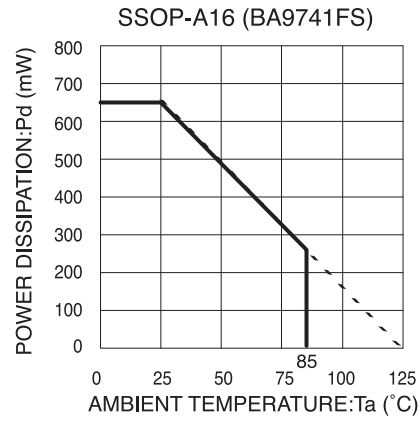
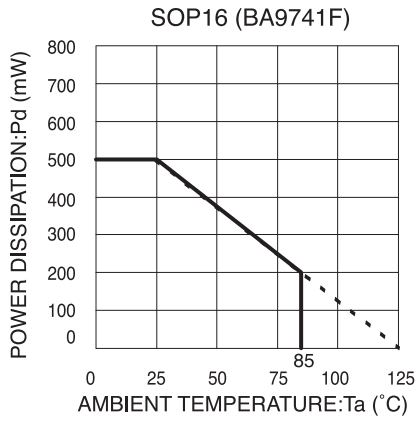

Note: When mounted on a printed circuit board of 70.0×70.0×1.6 mm (SOP16 and SSOP-A16)

When mounted on a printed circuit board of 50.0×50.0×1.6 mm (SSOP-B16)

●Ordering part number

B	A
---	---

Part No.

9	7	4	3	A
---	---	---	---	---

Part No.
9743A
9744
9741

F	V
---	---

Package
FV:SSOP-B16
FS:SSOP-A16
F:SOP16

-	E	2
---	---	---

Packaging and forming specification
E2: Embossed tape and reel

SSOP-B16

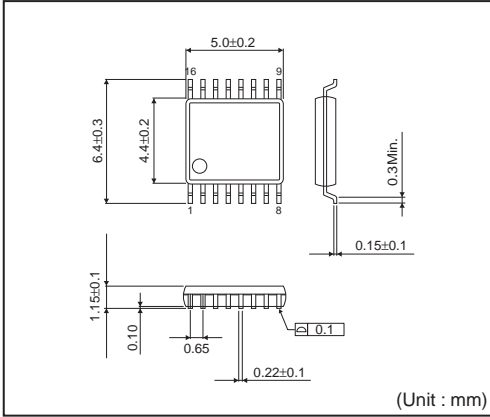

<Tape and Reel information>

Tape	Embossed carrier tape
Quantity	2500pcs
Direction of feed	E2 (The direction is the 1pin of product is at the upper left when you hold reel on the left hand and you pull out the tape on the right hand)

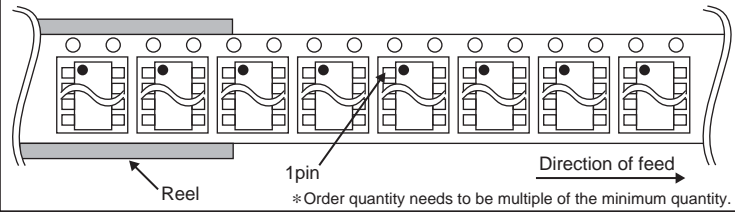

SSOP-A16

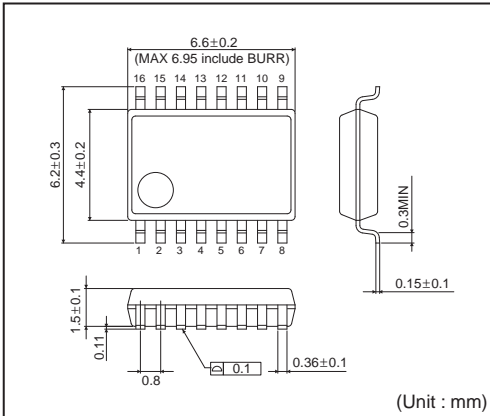

<Tape and Reel information>

Tape	Embossed carrier tape
Quantity	2500pcs
Direction of feed	E2 (The direction is the 1pin of product is at the upper left when you hold reel on the left hand and you pull out the tape on the right hand)

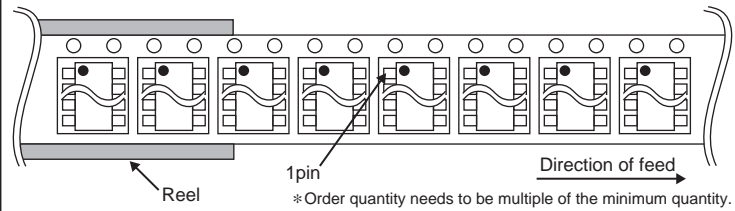

SOP16

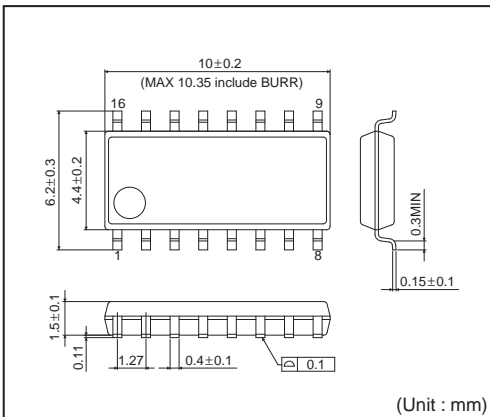

<Tape and Reel information>

Tape	Embossed carrier tape
Quantity	2500pcs
Direction of feed	E2 (The direction is the 1pin of product is at the upper left when you hold reel on the left hand and you pull out the tape on the right hand)

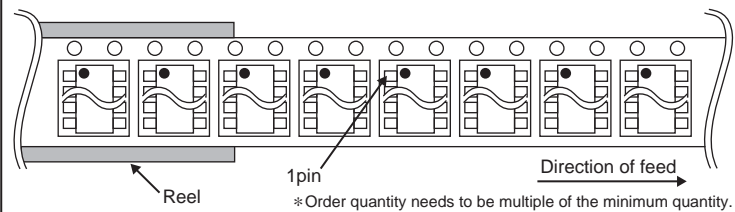

Notice

Precaution on using ROHM Products

- Our Products are designed and manufactured for application in ordinary electronic equipments (such as AV equipment, OA equipment, telecommunication equipment, home electronic appliances, amusement equipment, etc.). If you intend to use our Products in devices requiring extremely high reliability (such as medical equipment ^(Note 1), transport equipment, traffic equipment, aircraft/spacecraft, nuclear power controllers, fuel controllers, car equipment including car accessories, safety devices, etc.) and whose malfunction or failure may cause loss of human life, bodily injury or serious damage to property ("Specific Applications"), please consult with the ROHM sales representative in advance. Unless otherwise agreed in writing by ROHM in advance, ROHM shall not be in any way responsible or liable for any damages, expenses or losses incurred by you or third parties arising from the use of any ROHM's Products for Specific Applications.

(Note1) Medical Equipment Classification of the Specific Applications

JAPAN	USA	EU	CHINA
CLASS III	CLASS III	CLASS II b	CLASS III
CLASS IV		CLASS III	

- ROHM designs and manufactures its Products subject to strict quality control system. However, semiconductor products can fail or malfunction at a certain rate. Please be sure to implement, at your own responsibilities, adequate safety measures including but not limited to fail-safe design against the physical injury, damage to any property, which a failure or malfunction of our Products may cause. The following are examples of safety measures:
 - Installation of protection circuits or other protective devices to improve system safety
 - Installation of redundant circuits to reduce the impact of single or multiple circuit failure
- Our Products are designed and manufactured for use under standard conditions and not under any special or extraordinary environments or conditions, as exemplified below. Accordingly, ROHM shall not be in any way responsible or liable for any damages, expenses or losses arising from the use of any ROHM's Products under any special or extraordinary environments or conditions. If you intend to use our Products under any special or extraordinary environments or conditions (as exemplified below), your independent verification and confirmation of product performance, reliability, etc. prior to use, must be necessary:
 - Use of our Products in any types of liquid, including water, oils, chemicals, and organic solvents
 - Use of our Products outdoors or in places where the Products are exposed to direct sunlight or dust
 - Use of our Products in places where the Products are exposed to sea wind or corrosive gases, including Cl₂, H₂S, NH₃, SO₂, and NO₂
 - Use of our Products in places where the Products are exposed to static electricity or electromagnetic waves
 - Use of our Products in proximity to heat-producing components, plastic cords, or other flammable items
 - Sealing or coating our Products with resin or other coating materials
 - Use of our Products without cleaning residue of flux (even if you use no-clean type fluxes, cleaning residue of flux is recommended); or Washing our Products by using water or water-soluble cleaning agents for cleaning residue after soldering
 - Use of the Products in places subject to dew condensation
- The Products are not subject to radiation-proof design.
- Please verify and confirm characteristics of the final or mounted products in using the Products.
- In particular, if a transient load (a large amount of load applied in a short period of time, such as pulse. is applied, confirmation of performance characteristics after on-board mounting is strongly recommended. Avoid applying power exceeding normal rated power; exceeding the power rating under steady-state loading condition may negatively affect product performance and reliability.
- De-rate Power Dissipation (Pd) depending on Ambient temperature (Ta). When used in sealed area, confirm the actual ambient temperature.
- Confirm that operation temperature is within the specified range described in the product specification.
- ROHM shall not be in any way responsible or liable for failure induced under deviant condition from what is defined in this document.

Precaution for Mounting / Circuit board design

- When a highly active halogenous (chlorine, bromine, etc.) flux is used, the residue of flux may negatively affect product performance and reliability.
- In principle, the reflow soldering method must be used; if flow soldering method is preferred, please consult with the ROHM representative in advance.

For details, please refer to ROHM Mounting specification

Precautions Regarding Application Examples and External Circuits

1. If change is made to the constant of an external circuit, please allow a sufficient margin considering variations of the characteristics of the Products and external components, including transient characteristics, as well as static characteristics.
2. You agree that application notes, reference designs, and associated data and information contained in this document are presented only as guidance for Products use. Therefore, in case you use such information, you are solely responsible for it and you must exercise your own independent verification and judgment in the use of such information contained in this document. ROHM shall not be in any way responsible or liable for any damages, expenses or losses incurred by you or third parties arising from the use of such information.

Precaution for Electrostatic

This Product is electrostatic sensitive product, which may be damaged due to electrostatic discharge. Please take proper caution in your manufacturing process and storage so that voltage exceeding the Products maximum rating will not be applied to Products. Please take special care under dry condition (e.g. Grounding of human body / equipment / solder iron, isolation from charged objects, setting of Ionizer, friction prevention and temperature / humidity control).

Precaution for Storage / Transportation

1. Product performance and soldered connections may deteriorate if the Products are stored in the places where:
 - [a] the Products are exposed to sea winds or corrosive gases, including Cl₂, H₂S, NH₃, SO₂, and NO₂
 - [b] the temperature or humidity exceeds those recommended by ROHM
 - [c] the Products are exposed to direct sunshine or condensation
 - [d] the Products are exposed to high Electrostatic
2. Even under ROHM recommended storage condition, solderability of products out of recommended storage time period may be degraded. It is strongly recommended to confirm solderability before using Products of which storage time is exceeding the recommended storage time period.
3. Store / transport cartons in the correct direction, which is indicated on a carton with a symbol. Otherwise bent leads may occur due to excessive stress applied when dropping of a carton.
4. Use Products within the specified time after opening a humidity barrier bag. Baking is required before using Products of which storage time is exceeding the recommended storage time period.

Precaution for Product Label

QR code printed on ROHM Products label is for ROHM's internal use only.

Precaution for Disposition

When disposing Products please dispose them properly using an authorized industry waste company.

Precaution for Foreign Exchange and Foreign Trade act

Since our Products might fall under controlled goods prescribed by the applicable foreign exchange and foreign trade act, please consult with ROHM representative in case of export.

Precaution Regarding Intellectual Property Rights

1. All information and data including but not limited to application example contained in this document is for reference only. ROHM does not warrant that foregoing information or data will not infringe any intellectual property rights or any other rights of any third party regarding such information or data. ROHM shall not be in any way responsible or liable for infringement of any intellectual property rights or other damages arising from use of such information or data.:
2. No license, expressly or implied, is granted hereby under any intellectual property rights or other rights of ROHM or any third parties with respect to the information contained in this document.

Other Precaution

1. This document may not be reprinted or reproduced, in whole or in part, without prior written consent of ROHM.
2. The Products may not be disassembled, converted, modified, reproduced or otherwise changed without prior written consent of ROHM.
3. In no event shall you use in any way whatsoever the Products and the related technical information contained in the Products or this document for any military purposes, including but not limited to, the development of mass-destruction weapons.
4. The proper names of companies or products described in this document are trademarks or registered trademarks of ROHM, its affiliated companies or third parties.

General Precaution

1. Before you use our Products, you are requested to carefully read this document and fully understand its contents. ROHM shall not be in any way responsible or liable for failure, malfunction or accident arising from the use of any ROHM's Products against warning, caution or note contained in this document.
2. All information contained in this document is current as of the issuing date and subject to change without any prior notice. Before purchasing or using ROHM's Products, please confirm the latest information with a ROHM sales representative.
3. The information contained in this document is provided on an "as is" basis and ROHM does not warrant that all information contained in this document is accurate and/or error-free. ROHM shall not be in any way responsible or liable for any damages, expenses or losses incurred by you or third parties resulting from inaccuracy or errors of or concerning such information.

Looking for pricing, stock, or lifecycle information?

Click below to explore more details on WIN SOURCE:

- [View BA9744FV-E2 on WIN SOURCE](#)
- [Rohm Semiconductor Information](#)

Optimize Your Supply Chain with WIN SOURCE Solutions

- ✓ Global Sourcing Solution
- ✓ Obsolete Management
- ✓ Cost Control Management
- ✓ Shortage Management
- ✓ Alternative Solution
- ✓ Excess Inventory Management