



THE DATASHEET OF
498-0090



承認書

APPROVED DATA

Company Name : Digi International

Customer Part Number : _____

Pinrex Part Number : 984-63-052202

Description : Mini PCI Express Socket
0.8Pitch 52P



頻銳科技股份有限公司

PINREX TECHNOLOGY CORP.

3FL-3,NO.16,LANE 609,SEC.5,CHUNG HSIN ROAD
SAN CHUNG CITY,TAIPEI HSIEN,TAIWAN R.O.C.

TEL : (02) 2999-9001 FAX : (02) 2999-9002

本公司通過 QA ISO9000 及 140001 認證

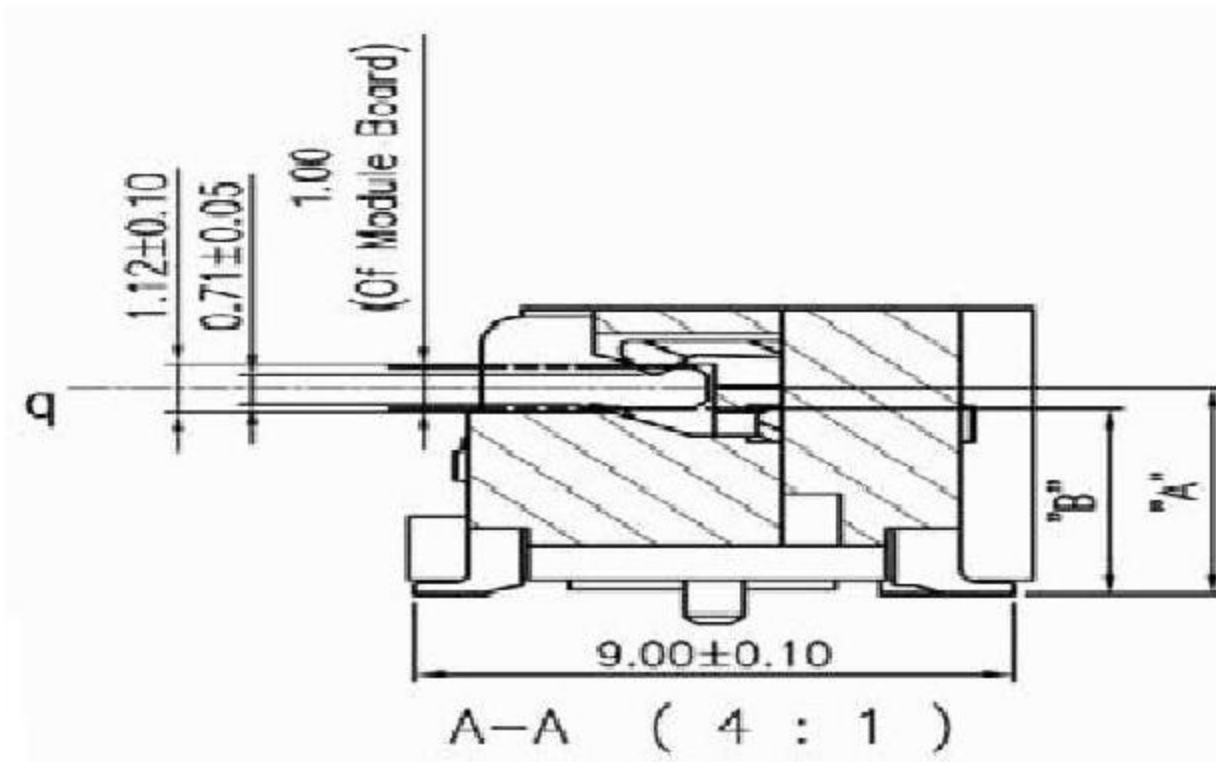
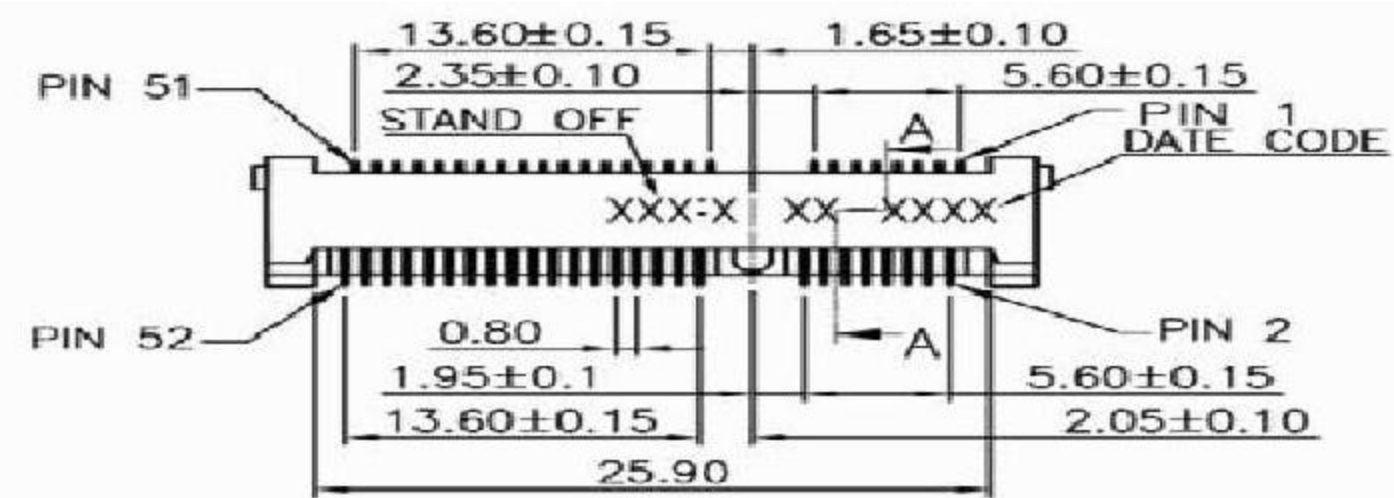

Material:
 Housing: High Temperature Plastic UL94V-0
 Contact: Brass
 Contact Area: Gold flash
 Solder: Lead Free

984- 63 - 052 2 0 2
 1 2 3 4 5

1. 1: Bag
- 2: TUBE
- 3: Tape Reel
2. 052: 52Pin
3. 1: DIP 90°
- 2: SMT 90°
4. 0: H=6.8mm A=4.9 B=4.4
5. Pinrex internal code.

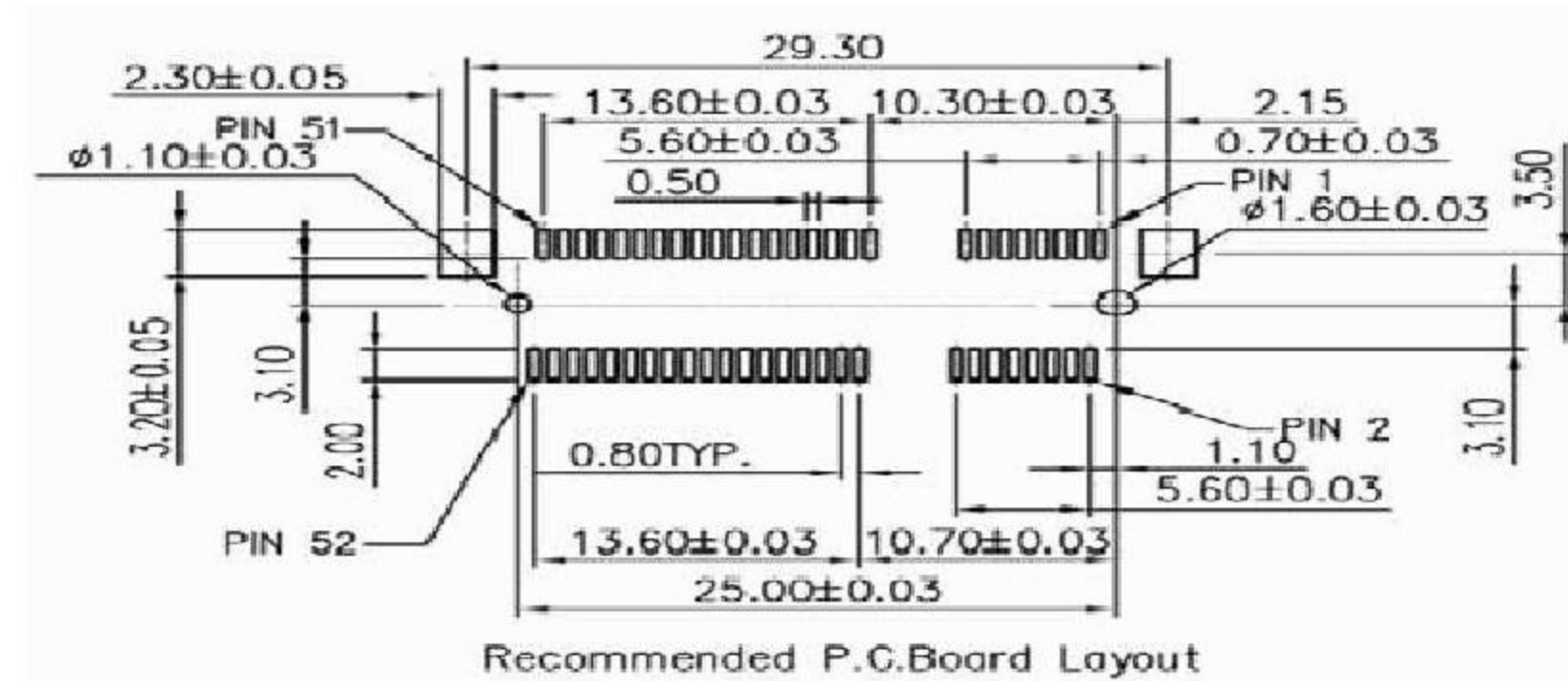
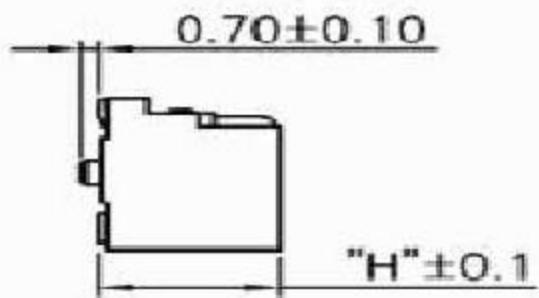
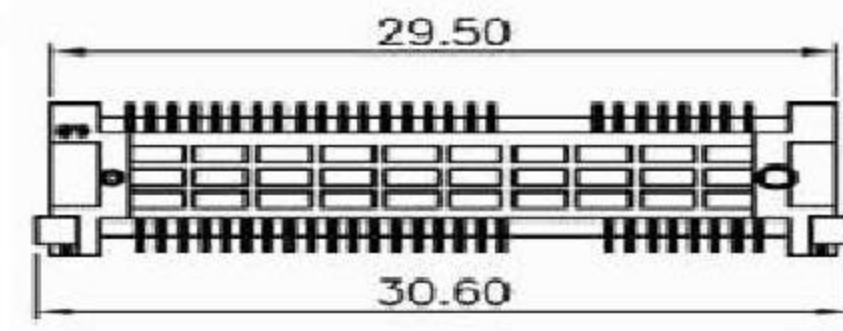
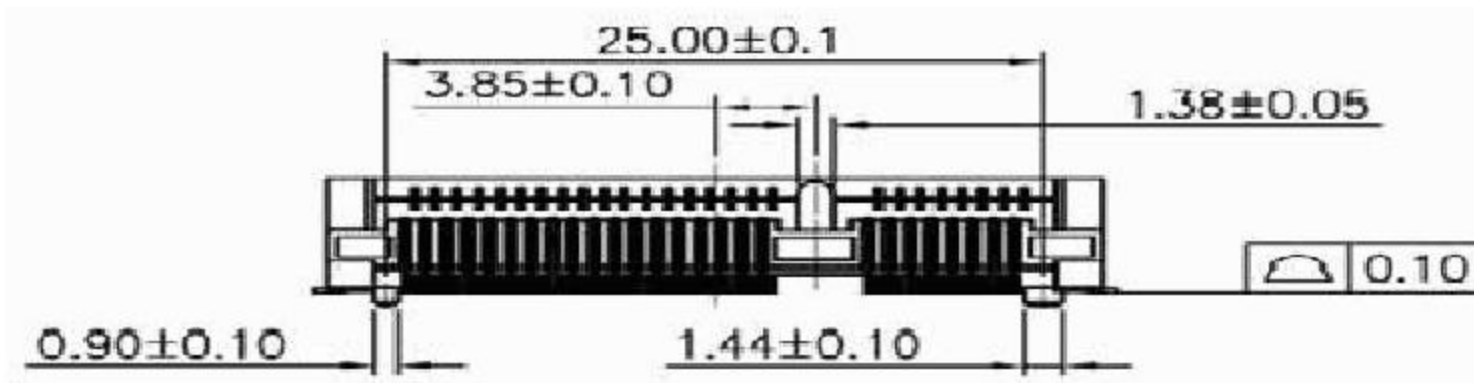

		TOLERANCE				OLD PART NO. 119A-68C00-R		TITLE MINI PCI Express Socket 0.8Pitch		頻銳科技股份有限公司 PINREX TECHNOLOGY CORP.	
		.0 =±.30		UNITS : mm		DRAWER Naomi		CHECK		DRAW NO.	
		.00 =±.20		SCALE		SHEET		REV.		NEW PART NO.	
		.000 =±.XXX		NONE		1 OF 1		A		984-63-052202	
A		RELEASE		2008/02/14						84-63-052202	
REV.		DESCRIPTION		DATE						984-63-052202	



ATTEND TECHNOLOGY INC.

SPECIFICATION AND PERFORMANCE

SERIES: 119A

DATE:2007/5/30

PAGE:1/3

Scope:

This specification covers the requirements for product performance, test methods and quality assurance provisions of Mini PCI Express.

Performance and Descriptions:

The product is designed to meet the electrical, mechanical and environmental performance requirements specification. Unless otherwise specified, all tests are performed at ambient environmental conditions.

ROHS:

All material in according with the ROHS environment related substances list controlled.

MATERIAL AND FINISH

INSULATOR	Material	Housing: High Temperature Plastic UL94V-0
	Plating	Contact Plating: 3u" and 15u" selective gold. Solder: Lead free.
CONTACT	Material	Brass
	Plating	Contact Plating: 3u" and 15u" selective gold. Solder: Lead free.
SHELL OR COVER	Material	Latch: Stainless
	Plating	
OTHERWISE SPECIFIED	Voltage rating: 50VAC Current: 0.5A Operating Temperature: -55°C~+85°C	



ATTEND TECHNOLOGY INC.

SPECIFICATION AND PERFORMANCE

SERIES:119A

DATE:2007/5/30

PAGE:2/3

ELECTRICAL

Item	Requirement	Test Condition
Contact resistance	30 milliohms	Subject mated contacts assembled in housing to closed circuit current of 10mA(max) at open circuit voltage of 20mV voltage(Max).
Insulation resistance	500M Ω (Min)	Measured by applying 500VDC between adjacent contacts of unmated connector.
Dielectric Strength	No breakdown Current leakage: 0.5mA	Measured by applying 250VAC for one minute between adjacent contacts of unmated connector assemblies. MIL-STD-202 method 301

MECHANICAL

Item	Requirement	Test Condition
Vibration test	No electrical discontinuity greater than 1 microsecond. $\Delta R=20m\Omega$ Max	Subject mated connectors to 10-55-10 Hz traversed in 1 minute at 1.52mm amplitude 2 hours each of 3 mutually perpendicular planes. MIL-STD-202 method 201.
Physical shock	1.No electrical discontinuity greater than 1 microsecond 2. $\Delta R=20m\Omega$ Max. No physical damage.	Subject mated connector to 50G's , half-sine shock pulses of 11 millisecond duration , 3drops in each direction applied along the 3 mutually perpendicular planes total 18 drops. MIL-STD-202 method 202.
PCB mating force	124pos. 51.5N(5.3Kgf) Max.	Operation speed: 100mm/min measure the force required to mate connectors.
Durability	$\Delta R=20m\Omega$ Max	Repeat insertion and extraction of PCB to and from the connector with the turns to lock it and then unlock it for 100 cycles.



ATTEND TECHNOLOGY INC.

SPECIFICATION AND PERFORMANCE

SERIES:119A

DATE:2007/5/30

PAGE:3/3

SOLDER ABILITY

Item	Requirement	Test Condition
Solder ability	Wet solder coverage: 95% Min.	Solder temperature: $260\pm 5^{\circ}\text{C}$ Immersion duration: $3\pm 0.5\text{sec}$.
Resistance to Soldering heat.	No physical damage.	

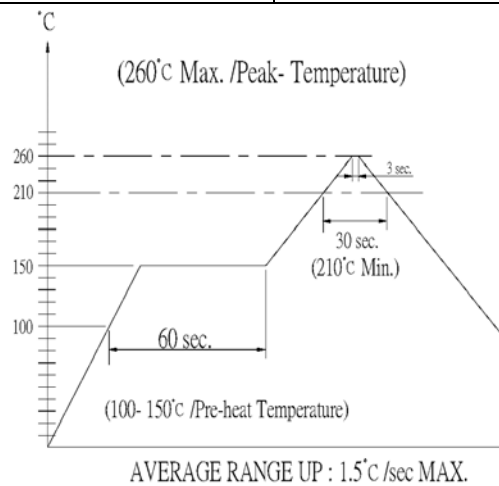

TEMPERATURE CONDITION GRAPH
(TEMPERATURE ON BOARD PATTERN SIDE)

ENVIRONMENTAL

Item	Requirement	Test Condition
Humidity	1.Contact resistance: $\Delta R=20\text{m}\Omega$ Max 2.Insulation resistance: $500\text{m}\Omega$ Min. 3.No physical damage.	Expose the mated connectors to $40\pm 2^{\circ}\text{C}$ Relative humidity 90~95% for 96 hours. MIL-STD-202 method 103.
Thermal shock	1.Contact resistance: $\Delta R=20\text{m}\Omega$ Max. No physical damage	Expose the mated connectors to $-55^{\circ}\text{C}/30\text{min}$ and $85^{\circ}\text{C}/30\text{min}$. Repeat 5 cycles.

測試報告

號碼 : CE/2006/C3886 日期 : 2006/12/25 頁數 : 1 of 4

福興實業股份有限公司

FU HSING INDUSTRIAL CO., LTD.

台北市延平南路74號

74, YEN PING SOUTH ROAD, TAIPEI, 100-34 TAIWAN



本報告為客戶所委託的樣品，樣品名稱為"VECTRA LCP"所做的測試。

Report on the submitted sample said to be VECTRA LCP.

樣品型號(Style/Item No) : A130 BK010P、E130i BK205P、E130i BK210P、E130i BK211P、E471i BK210P、E471i BK211P、E472i BK210P、E473i BK210P、E480i BK210P、T130 BK005P、S135 BK010P、A150B BK213P、L140 BK210P

收件日期(Sample Receiving Date) : 2006/12/18

測試期間(Testing Period) : 2006/12/18 TO 2006/12/25

=====
測試需求 / Test Requested : 參照 RoHS 2002/95/EC 及其修定指令要求。 / In accordance with the RoHS Directive 2002/95/EC, and its amendment directives.

測試方法 / Test Method : (1) 參考BS EN 1122方法B:2001, 用感應耦合電漿原子發射光譜儀檢測鎘含量。 / With reference to BS EN 1122:2001, Method B for Cadmium Content. Analysis was performed by ICP-AES.
(2) 參考US EPA 3050B方法, 用感應耦合電漿原子發射光譜儀檢測鉛含量。 / With reference to US EPA Method 3050B for Lead Content. Analysis was performed by ICP-AES.
(3) 參考US EPA 3052方法, 用感應耦合電漿原子發射光譜儀檢測汞含量。 / With reference to US EPA Method 3052 for Mercury Content. Analysis was performed by ICP-AES.
(4) 針對非金屬材質之樣品, 參考IEC 62321, Ed. 1 111/54/CDV方法檢測, 用UV-VIS檢測六價鉻含量。 / With reference to IEC 62321, Ed.1 111/54/CDV. Determination of Hexavalent Chromium for non-metallic samples by UV/Vis Spectrometry.
(5) 參考US EPA 3540C方法, 以氣相層析儀/質譜儀(GC/MS)檢測多溴聯苯和多溴聯苯醚含量。 / With reference to US EPA 3540C for PBBs/PBDEs Content. Analysis was performed by GC/MS.

測試結果 / Test Result(s) : 請見下一頁。

Daniel Yeh, M.R. / Operation Manager
Signed for and on behalf of
SGS TAIWAN LTD.

測試報告

號碼：CE/2006/C3886

日期：2006/12/25

頁數：2 of 4

福興實業股份有限公司

FU HSING INDUSTRIAL CO., LTD.

台北市延平南路74號

74, YEN PING SOUTH ROAD, TAIPEI, 100-34 TAIWAN



測試結果 (單位: mg/kg) / Test Result(s)

測試項目 / Test Item (s):	測試方法 Method (Refer to)	結果 / Result	
		No.1	方法偵測 極限值 (MDL)
鎘 / Cadmium (Cd)	(1)	n.d.	2
鉛 / Lead (Pb)	(2)	n.d.	2
汞 / Mercury (Hg)	(3)	n.d.	2
六價鉻 / Hexavalent Chromium (CrVI) by alkaline extraction	(4)	n.d.	2
多溴聯苯總和 / Sum of PBBs	(5)	n.d.	-
一溴聯苯 / Monobromobiphenyl		n.d.	5
二溴聯苯 / Dibromobiphenyl		n.d.	5
三溴聯苯 / Tribromobiphenyl		n.d.	5
四溴聯苯 / Tetrabromobiphenyl		n.d.	5
五溴聯苯 / Pentabromobiphenyl		n.d.	5
六溴聯苯 / Hexabromobiphenyl		n.d.	5
七溴聯苯 / Heptabromobiphenyl		n.d.	5
八溴聯苯 / Octabromobiphenyl		n.d.	5
九溴聯苯 / Nonabromobiphenyl		n.d.	5
十溴聯苯 / Decabromobiphenyl		n.d.	5
多溴聯苯醚總和 (一至九溴) / Sum of PBDEs (Mono to Nona) (Note 4)		n.d.	-
一溴聯苯醚 / Monobromobiphenyl ether		n.d.	5
二溴聯苯醚 / Dibromobiphenyl ether		n.d.	5
三溴聯苯醚 / Tribromobiphenyl ether		n.d.	5
四溴聯苯醚 / Tetrabromobiphenyl ether		n.d.	5
五溴聯苯醚 / Pentabromobiphenyl ether		n.d.	5
六溴聯苯醚 / Hexabromobiphenyl ether		n.d.	5
七溴聯苯醚 / Heptabromobiphenyl ether		n.d.	5
八溴聯苯醚 / Octabromobiphenyl ether		n.d.	5
九溴聯苯醚 / Nonabromobiphenyl ether		n.d.	5
十溴聯苯醚 / Decabromobiphenyl ether	n.d.	5	
多溴聯苯醚總和 (一至十溴) / Sum of PBDEs (Mono to Deca)	n.d.	-	

測試部位描述 / Test Part Description:

NO.1 : 混測黑色塑膠粒 / MIXED BLACK PLASTIC PELLETS

測試報告

號碼：CE/2006/C3886

日期：2006/12/25

頁數：3 of 4

福興實業股份有限公司

FU HSING INDUSTRIAL CO., LTD.

台北市延平南路74號

74, YEN PING SOUTH ROAD, TAIPEI, 100-34 TAIWAN



Note: 1. mg/kg = ppm

2. n.d. = Not Detected / 未檢出

3. MDL = Method Detection Limit / 方法偵測極限值

4. Sum of Mono to NonaBDE & according to 2005/717/EC DecaBDE is exempt.

根據2005年10月13日歐盟會議公佈2005/717/EC，修訂2002/95/EC內容，通過解除
高分子材質中十溴聯苯醚之使用限制。

5. "-" = Not Regulated / 無規格值

測試報告

號碼 : CE/2006/C3886

日期 : 2006/12/25

頁數 : 4 of 4

福興實業股份有限公司

FU HSING INDUSTRIAL CO., LTD.

台北市延平南路74號

74, YEN PING SOUTH ROAD, TAIPEI, 100-34 TAIWAN



** 報告結尾 **

Test Report

MINCHALI METAL INDUSTRY CO., LTD.
11, PEI YUAN ROAD, CHUNG LI CITY, TAIWAN, R. O. C.

No : CE/2006/A1255
Date : 20061016
Page : 1 of 5



The following sample(s) was/were submitted and identified by/on behalf of the client as :

Sample Description : 黃銅
Style/Item No : C2680 (65/35)
Manufacturer/Vendor : MINCHALI METAL INDUSTRY CO., LTD.
Country of Origin : TAIWAN
Sample Receiving Date : 2006/10/5
Testing Period : 2006/10/5 TO 2006/10/16

=====
Test Result(s) : Please refer to next page(s).

Daniel Yeh, M.R. / Operation Manager
Signed for and on behalf of
SGS TAIWAN LTD.

Test Report

MINCHALI METAL INDUSTRY CO., LTD.
11, PEI YUAN ROAD, CHUNG LI CITY, TAIWAN, R. O. C.

No : CE/2006/A1255

Date : 20061016

Page : 2 of 5



Test Result(s)

PART NAME NO.1 : GOLDEN COLORED METAL SHEET

PASS

Test Item (s):	Unit	Method	MDL	Result	Spec.
				No.1	
EN 71 PART 3 Heavy metal content	--	As per EN 71 PART 3 : 1994 (A1 : 2000, AC:2000 and AC:2002) (EN 71 & BS 5665 are identical)	--	---	--
Soluble Lead (Pb)	mg/kg	ICP-AES	5	< 5.0	90
Soluble Antimony (Sb)	mg/kg	ICP-AES	5	< 5.0	60
Soluble Arsenic (As)	mg/kg	ICP-AES	2.5	< 2.5	25
Soluble Barium (Ba)	mg/kg	ICP-AES	10	30.3	1000
Soluble Cadmium (Cd)	mg/kg	ICP-AES	5	< 5.0	75
Soluble Chromium (Cr)	mg/kg	ICP-AES	5	< 5.0	60
Soluble Mercury (Hg)	mg/kg	ICP-AES	5	< 5.0	60
Soluble Selenium (Se)	mg/kg	ICP-AES	5	< 5.0	500

Test Item (s):	Unit	Method	MDL	Result	Spec.
				No.1	
Cadmium (Cd)	mg/kg	With reference to BS EN 1122:2001, Method B for Cadmium Content. Analysis was performed by ICP-AES.	2	n.d.	-
Lead (Pb)	mg/kg	With reference to US EPA Method 3050B for Lead Content. Analysis was performed by ICP-AES.	2	18.5	-
Mercury (Hg)	mg/kg	With reference to US EPA Method 3052 for Mercury Content. Analysis was performed by ICP-AES.	2	n.d.	-
Chromium VI (Cr+6)	mg/kg	With reference to US EPA Method 3060A & 7196A for Hexavalent Chromium. Analysis was performed by UV/Vis Spectrometry.	2	n.d.	-

Test Report

MINCHALI METAL INDUSTRY CO., LTD.
11, PEI YUAN ROAD, CHUNG LI CITY, TAIWAN, R. O. C.

No : CE/2006/A1255

Date : 20061016

Page : 3 of 5



Test Item (s):	Unit	Method	MDL	Result	Spec.
				No.1	
Sum of PBBs	mg/kg	With reference to US EPA 3540C for PBB/PBDE Content. Analysis was performed by GC/MS and screening via US EPA 3550C with HPLC/DAD/MS.	-	n.d.	-
Monobromobiphenyl			5	n.d.	-
Dibromobiphenyl			5	n.d.	-
Tribromobiphenyl			5	n.d.	-
Tetrabromobiphenyl			5	n.d.	-
Pentabromobiphenyl			5	n.d.	-
Hexabromobiphenyl			5	n.d.	-
Heptabromobiphenyl			5	n.d.	-
Octabromobiphenyl			5	n.d.	-
Nonabromobiphenyl			5	n.d.	-
Decabromobiphenyl			5	n.d.	-
Sum of PBDEs (Mono to Nona) (Note 4)			-	n.d.	-
Monobromobiphenyl ether			5	n.d.	-
Dibromobiphenyl ether			5	n.d.	-
Tribromobiphenyl ether			5	n.d.	-
Tetrabromobiphenyl ether			5	n.d.	-
Pentabromobiphenyl ether			5	n.d.	-
Hexabromobiphenyl ether			5	n.d.	-
Heptabromobiphenyl ether			5	n.d.	-
Octabromobiphenyl ether			5	n.d.	-
Nonabromobiphenyl ether			5	n.d.	-
Decabromobiphenyl ether			5	n.d.	-
Sum of PBDEs (Mono to Deca)			-	n.d.	-

Note : 1. mg/kg = ppm

2. n.d. = Not Detected

3. MDL = Method Detection Limit

4. Sum of Mono to NonaBDE & according to 2005/717/EC DecaBDE is exempt.

5. "---" = Not Conducted

6. "-" = Not Regulated

Test Report

MINCHALI METAL INDUSTRY CO., LTD.
11, PEI YUAN ROAD, CHUNG LI CITY, TAIWAN, R. O. C.

No : CE/2006/A1255

Date : 20061016

Page : 4 of 5



- 1) These samples were dissolved totally by pre-conditioning method according to below flow chart.
- 2) Name of the person who made measurement: Anren Lee
- 3) Name of the person in charge of measurement: Daniel Yeh

Method 1: Flow Chart of Digestion for Cd - Pb analysis

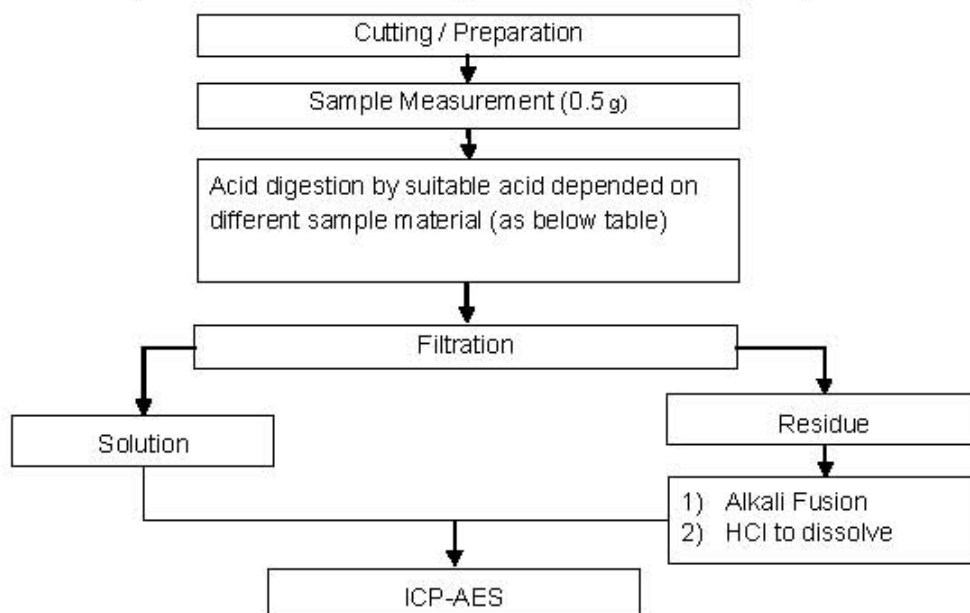

Steel, copper, aluminum, solder	Aqua regia, HNO ₃ , HCl, HF, H ₂ O ₂
Glass	HNO ₃ /HF
Gold, platinum, palladium, ceramic	Aqua regia
Silver	HNO ₃
Plastic	H ₂ SO ₄ , H ₂ O ₂ , HNO ₃ , HCl
Others	Any acid to total digestion

Test Report

MINCHALI METAL INDUSTRY CO., LTD.
11, PEI YUAN ROAD, CHUNG LI CITY, TAIWAN, R. O. C.

No : CE/2006/A1255

Date : 20061016

Page : 5 of 5



** End of Report **



Test Report

No.: GZ0703040006/CHEM

Date: MAR 28, 2007

Page 1 of 3

XINHAO SURFACE TREATMENT CO., LTD
A3 2 FLOOR, XINGANGLIAN INDUSTRIAL ZONE, HONGXING VILLAGE, SONGGANG TOWN, SHENZHEN CITY IN
CHINA

The following sample(s) was/were submitted and identified on behalf of the applicant as Gold plating sample

SGS Ref No. : SZ10293568-5.3
Sample Receiving Date : MAR 22, 2007
Testing Period : MAR 22, 2007 TO MAR 28, 2007

Test Requested : In accordance with the RoHS Directive 2002/95/EC, and its amendment directives.

Test Method : With reference to IEC 62321 Ed.1 111/54/CDV
Procedures for the Determination of Levels of Regulated Substances in Electrotechnical Products
(1) Determination of Cadmium by ICP.
(2) Determination of Lead by ICP.
(3) Determination of Mercury by ICP.
(4) Determination of Hexavalent Chromium by Colorimetric Method.

Test Results : Please refer to next page.

Conclusion : Based on the performed tests on submitted sample(s), the results **comply with** the RoHS
Directive 2002/95/EC and its subsequent amendments.

Signed for and on behalf of
SGS-CSTC Ltd.

Jiang YongPing, Terry
Sr. Engineer

This Test Report is issued by the Company subject to its General Conditions of Service printed overleaf or available on request and accessible at www.sgs.com. Attention is drawn to the limitations of liability, indemnification and jurisdictional issues defined therein. Unless otherwise stated the results shown in this test report refer only to the sample(s) tested. This test report cannot be reproduced, except in full, without prior written permission of the Company. Any unauthorized alteration, forgery or falsification of the content or appearance of this report is unlawful and offenders may be prosecuted to the fullest extent of the law.

SGS-CSTC Standards Technical Services Co., Ltd.
Guangzhou Branch / Chemical Laboratory

188 Kezhu Road SCIENTECH Park Guangzhou Economic & Technology Development District Guangzhou China 510663
中国·广州·经济技术开发区科学城科珠路188号 邮编: 510663

t (86-20) 82155555

f (86-20) 82075125

www.cn.sgs.com

f (86-20) 82075125

e sgs.china@sgs.com

GZCM 977336

Member of the SGS Group (SGS SA)

Test results by chemical method (Unit: mg/kg)

Test Item(s):	Method (refer to)	No. 1	MDL	RoHS Limit
Cadmium(Cd)	(1)	N.D.	2	100
Lead (Pb)	(2)	34	2	1000
Mercury (Hg)	(3)	N.D.	2	1000
Hexavalent Chromium (CrVI) by Spot test	(4)	Negative	See Note 4	#

Test Part Description:

No.1 Golden plated copper-colored metal sheet

Note : 1. mg/kg = ppm

2. N.D. = Not Detected (< MDL)

3. MDL = Method Detection Limit

4. Spot-test:

Negative = Absence of CrVI coating, Positive = Presence of CrVI coating;

(The tested sample should be further verified by boiling-water-extraction method if the spot test result cannot be confirmed.)

Boiling-water-extraction:

Negative = Absence of CrVI coating

Positive = Presence of CrVI coating; the detected concentration in boiling-water-extraction solution is equal or greater than 0.02 mg/kg with 50 cm² sample surface area.

5. # = Positive indicates the presence of CrVI on the tested areas and result be regarded as conflict with RoHS requirement.

Negative indicates the absence of CrVI on the tested areas and result be regarded as no conflict with RoHS requirement.

This Test Report is issued by the Company subject to its General Conditions of Service printed overleaf or available on request and accessible at www.sgs.com. Attention is drawn to the limitations of liability, indemnification and jurisdictional issues defined therein. Unless otherwise stated the results shown in this test report refer only to the sample(s) tested. This test report cannot be reproduced, except in full, without prior written permission of the Company. Any unauthorized alteration, forgery or falsification of the content or appearance of this report is unlawful and offenders may be prosecuted to the fullest extent of the law.

Sample photo :

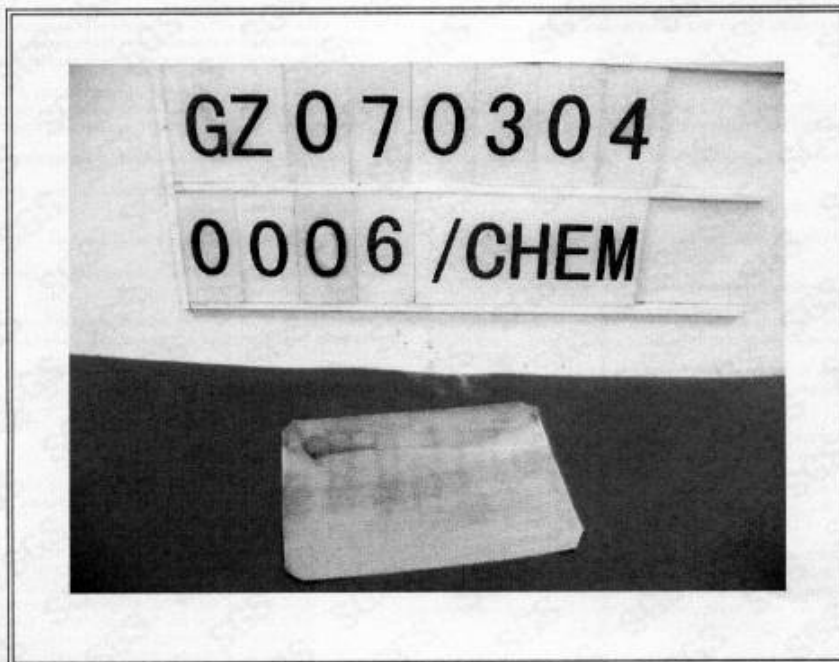

SGS authenticate the photo on original report only

*** End of Report ***

This Test Report is issued by the Company subject to its General Conditions of Service printed overleaf or available on request and accessible at www.sgs.com. Attention is drawn to the limitations of liability, indemnification and jurisdictional issues defined therein. Unless otherwise stated the results shown in this test report refer only to the sample(s) tested. This test report cannot be reproduced, except in full, without prior written permission of the Company. Any unauthorized alteration, forgery or falsification of the content or appearance of this report is unlawful and offenders may be prosecuted to the fullest extent of the law.



Test Report

No.: GZ0703040008/CHEM

Date: MAR 28, 2007

Page 1 of 3

XINHAO SURFACE TREATMENT CO., LTD
A3 2 FLOOR, XINGANGLIAN INDUSTRIAL ZONE, HONGXING VILLAGE, SONGGANG TOWN, SHENZHEN CITY IN
CHINA

The following sample(s) was/were submitted and identified on behalf of the applicant as Ni plating sample

SGS Ref No. : SZ10293568-5.5
Sample Receiving Date : MAR 22, 2007
Testing Period : MAR 22, 2007 TO MAR 28, 2007

Test Requested : In accordance with the RoHS Directive 2002/95/EC, and its amendment directives.

Test Method : With reference to IEC 62321 Ed.1 111/54/CDV
Procedures for the Determination of Levels of Regulated Substances in Electrotechnical Products
(1) Determination of Cadmium by ICP.
(2) Determination of Lead by ICP.
(3) Determination of Mercury by ICP.
(4) Determination of Hexavalent Chromium by Colorimetric Method.

Test Results : Please refer to next page.

Conclusion : Based on the performed tests on submitted sample(s), the results **comply with the RoHS**
Directive 2002/95/EC and its subsequent amendments.

Signed for and on behalf of
SGS-CSTC Ltd.

Jiang YongPing, Terry
Sr. Engineer

This Test Report is issued by the Company subject to its General Conditions of Service printed overleaf or available on request and accessible at www.sgs.com. Attention is drawn to the limitations of liability, indemnification and jurisdictional issues defined therein. Unless otherwise stated the results shown in this test report refer only to the sample(s) tested. This test report cannot be reproduced, except in full, without prior written permission of the Company. Any unauthorized alteration, forgery or falsification of the content or appearance of this report is unlawful and offenders may be prosecuted to the fullest extent of the law.

SGS-CSTC Standards Technical Services Co., Ltd.
Guangzhou Branch

19# Keshu Road, SCIENTECH Park, Guangzhou Economic & Technology Development District, Guangzhou, China 510663
中国·广州·经济技术开发区科学城科珠路198号 邮编: 510663

t (86-20) 82155555
t (86-20) 82155555

f (86-20) 82075125
f (86-20) 82075125

www.cn.sgs.com
e sgs.china@sgs.com

GZCM 977330

Test results by chemical method (Unit: mg/kg)

Test Item(s):	Method (refer to)	No.1	MDL	RoHS Limit
Cadmium(Cd)	(1)	N.D.	2	100
Lead (Pb)	(2)	34	2	1000
Mercury (Hg)	(3)	N.D.	2	1000
Hexavalent Chromium (CrVI) by Spot test	(4)	Negative	See Note 4	#

Test Part Description:

No.1 Silver-gray plated copper-colored metal sheet

Note : 1. mg/kg = ppm

2. N.D. = Not Detected (< MDL)

3. MDL = Method Detection Limit

4. Spot-test:

Negative = Absence of CrVI coating, Positive = Presence of CrVI coating;

(The tested sample should be further verified by boiling-water-extraction method if the spot test result cannot be confirmed.)

Boiling-water-extraction:

Negative = Absence of CrVI coating

Positive = Presence of CrVI coating; the detected concentration in boiling-water-extraction solution is equal or greater than 0.02 mg/kg with 50 cm² sample surface area.

5. # = Positive indicates the presence of CrVI on the tested areas and result be regarded as conflict with RoHS requirement.

Negative indicates the absence of CrVI on the tested areas and result be regarded as no conflict with RoHS requirement.

This Test Report is issued by the Company subject to its General Conditions of Service printed overleaf or available on request and accessible at www.sgs.com. Attention is drawn to the limitations of liability, indemnification and jurisdictional issues defined therein. Unless otherwise stated the results shown in this test report refer only to the sample(s) tested. This test report cannot be reproduced, except in full, without prior written permission of the Company. Any unauthorized alteration, forgery or falsification of the content or appearance of this report is unlawful and offenders may be prosecuted to the fullest extent of the law.

Sample photo :

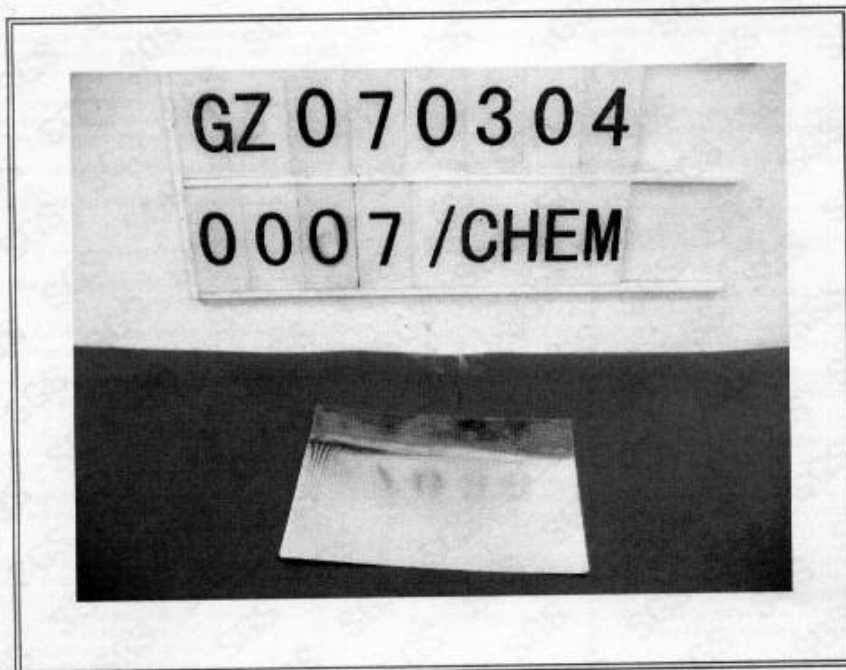

SGS authenticate the photo on original report only

*** End of Report ***

This Test Report is issued by the Company subject to its General Conditions of Service printed overleaf or available on request and accessible at www.sgs.com. Attention is drawn to the limitations of liability, indemnification and jurisdictional issues defined therein. Unless otherwise stated the results shown in this test report refer only to the sample(s) tested. This test report cannot be reproduced, except in full, without prior written permission of the Company. Any unauthorized alteration, forgery or falsification of the content or appearance of this report is unlawful and offenders may be prosecuted to the fullest extent of the law.





Looking for pricing, stock, or lifecycle information?

Click below to explore more details on WIN SOURCE:

 [View 498-0090](#) on WIN SOURCE

 [Digi International](#) Information

Optimize Your Supply Chain with WIN SOURCE Solutions

-  Global Sourcing Solution
-  Obsolete Management
-  Cost Control Management
-  Shortage Management
-  Alternative Solution
-  Excess Inventory Management