



**THE DATASHEET OF  
74HCT4351N,112**



## Important notice

Dear Customer,

On 7 February 2017 the former NXP Standard Product business became a new company with the tradename **Nexperia**. Nexperia is an industry leading supplier of Discrete, Logic and PowerMOS semiconductors with its focus on the automotive, industrial, computing, consumer and wearable application markets

In data sheets and application notes which still contain NXP or Philips Semiconductors references, use the references to Nexperia, as shown below.

Instead of <http://www.nxp.com>, <http://www.philips.com/> or <http://www.semiconductors.philips.com/>, use <http://www.nexperia.com>

Instead of [sales.addresses@www.nxp.com](mailto:sales.addresses@www.nxp.com) or [sales.addresses@www.semiconductors.philips.com](mailto:sales.addresses@www.semiconductors.philips.com), use [salesaddresses@nexperia.com](mailto:salesaddresses@nexperia.com) (email)

Replace the copyright notice at the bottom of each page or elsewhere in the document, depending on the version, as shown below:

- © NXP N.V. (year). All rights reserved or © Koninklijke Philips Electronics N.V. (year). All rights reserved

Should be replaced with:

- © **Nexperia B.V. (year). All rights reserved.**

If you have any questions related to the data sheet, please contact our nearest sales office via e-mail or telephone (details via [salesaddresses@nexperia.com](mailto:salesaddresses@nexperia.com)). Thank you for your cooperation and understanding,

Kind regards,

Team Nexperia

# DATA SHEET

For a complete data sheet, please also download:

- The IC06 74HC/HCT/HCU/HCMOS Logic Family Specifications
- The IC06 74HC/HCT/HCU/HCMOS Logic Package Information
- The IC06 74HC/HCT/HCU/HCMOS Logic Package Outlines

## **74HC/HCT4351** 8-channel analog multiplexer/demultiplexer with latch

Product specification  
File under Integrated Circuits, IC06

December 1990

# 8-channel analog multiplexer/demultiplexer with latch

74HC/HCT4351

## FEATURES

- Wide analog input voltage range:  
± 5 V
- Low "ON" resistance:  
80 Ω (typ.) at  $V_{CC} - V_{EE} = 4.5$  V  
70 Ω (typ.) at  $V_{CC} - V_{EE} = 6.0$  V  
60 Ω (typ.) at  $V_{CC} - V_{EE} = 9.0$  V
- Logic level translation: to enable 5 V logic to communicate with ± 5 V analog signals
- Typical "break before make" built in
- Address latches provided
- Output capability: non-standard
- $I_{CC}$  category: MSI

## GENERAL DESCRIPTION

The 74HC/HCT4351 are high-speed Si-gate CMOS devices. They are specified in compliance with JEDEC standard no. 7A.

The 74HC/HCT4351 are 8-channel analog multiplexers/demultiplexers with three select inputs ( $S_0$  to  $S_2$ ), two enable inputs ( $\bar{E}_1$  and  $E_2$ ), a latch enable input ( $\bar{LE}$ ), eight independent inputs/outputs ( $Y_0$  to  $Y_7$ ) and a common input/output ( $Z$ ).

With  $\bar{E}_1$  LOW and  $E_2$  is HIGH, one of the eight switches is selected (low impedance ON-state) by  $S_0$  to  $S_2$ . The data at the select inputs may be latched by using the active LOW latch enable input ( $\bar{LE}$ ). When  $\bar{LE}$  is HIGH the latch is transparent. When either of the two enable inputs,  $\bar{E}_1$  (active LOW) and  $E_2$  (active HIGH), is inactive, all 8 analog switches are turned off.

$V_{CC}$  and GND are the supply voltage pins for the digital control inputs ( $S_0$  to  $S_2$ ,  $\bar{LE}$ ,  $\bar{E}_1$  and  $E_2$ ). The  $V_{CC}$  to GND ranges are 2.0 to 10.0 V for HC and 4.5 to 5.5 V for HCT. The analog inputs/outputs ( $Y_0$  to  $Y_7$ , and  $Z$ ) can swing between  $V_{CC}$  as a positive limit and  $V_{EE}$  as a negative limit.

$V_{CC} - V_{EE}$  may not exceed 10.0 V.

For operation as a digital multiplexer/demultiplexer,  $V_{EE}$  is connected to GND (typically ground).

## QUICK REFERENCE DATA

$V_{EE} = \text{GND} = 0$  V;  $T_{\text{amb}} = 25$  °C;  $t_r = t_f = 6$  ns

SYMBOL	PARAMETER	CONDITIONS	TYPICAL		UNIT
			HC	HCT	
$t_{PZH} / t_{PZL}$	turn "ON" time $\bar{E}_1$ , $E_2$ or $S_n$ to $V_{os}$	$C_L = 15$ pF; $R_L = 1$ kΩ; $V_{CC} = 5$ V	27	35	ns
$t_{PHZ} / t_{PLZ}$	turn "OFF" time $\bar{E}_1$ , $E_2$ or $S_n$ to $V_{os}$		21	23	ns
$C_I$	input capacitance		3.5	3.5	pF
$C_{PD}$	power dissipation capacitance per switch	notes 1 and 2	25	25	pF
$C_S$	max. switch capacitance independent (Y) common (Z)		5	5	pF
			25	25	pF

## Notes

1.  $C_{PD}$  is used to determine the dynamic power dissipation ( $P_D$  in μW):

$$P_D = C_{PD} \times V_{CC}^2 \times f_i + \sum \{(C_L + C_S) \times V_{CC}^2 \times f_o\}$$

where:

$f_i$  = input frequency in MHz

$f_o$  = output frequency in MHz

$C_L$  = output load capacitance in pF

$C_S$  = max. switch capacitance in pF

$\sum \{(C_L + C_S) \times V_{CC}^2 \times f_o\}$  = sum of outputs

$V_{CC}$  = supply voltage in V

2. For HC the condition is  $V_I = \text{GND}$  to  $V_{CC}$   
For HCT the condition is  $V_I = \text{GND}$  to  $V_{CC} - 1.5$  V

## ORDERING INFORMATION

See "74HC/HCT/HCU/HCMOS Logic Package Information".

# 8-channel analog multiplexer/demultiplexer with latch

74HC/HCT4351

## PIN DESCRIPTION

PIN NO.	SYMBOL	NAME AND FUNCTION
4	Z	common
3, 14	n.c.	not connected
7	$\overline{E}_1$	enable input (active LOW)
8	$E_2$	enable input (active HIGH)
9	$V_{EE}$	negative supply voltage
10	GND	ground (0 V)
11	$\overline{LE}$	latch enable input (active LOW)
15, 13, 12	$S_0$ to $S_2$	select inputs
17, 18, 19, 16, 1, 6, 2, 5	$Y_0$ to $Y_7$	independent inputs/outputs
20	$V_{CC}$	positive supply voltage

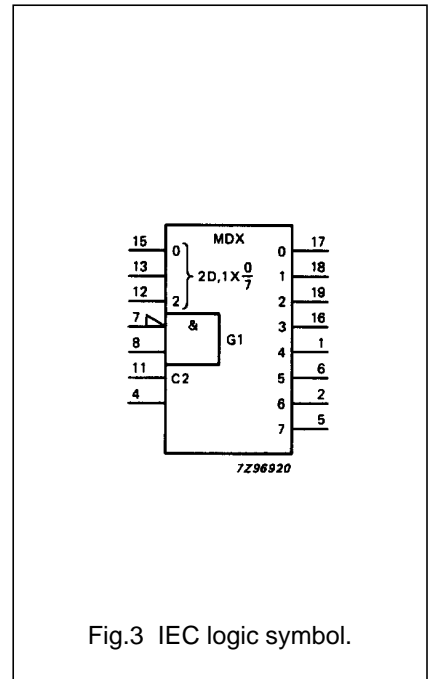
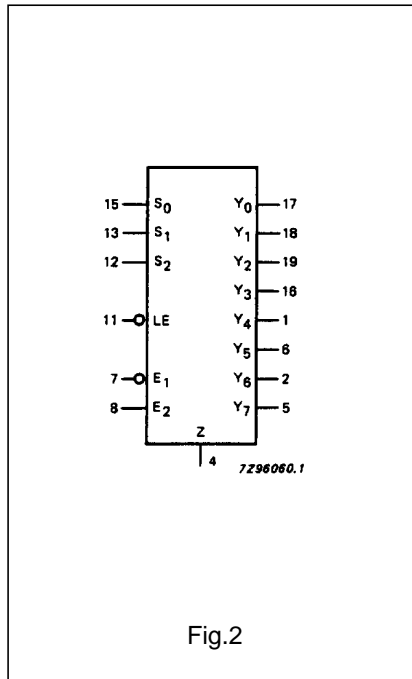
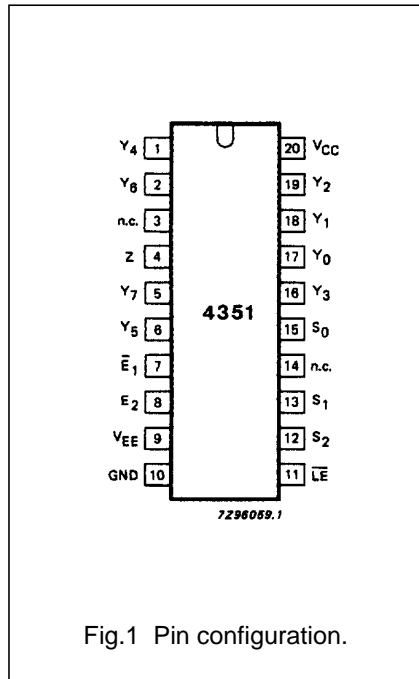

# 8-channel analog multiplexer/demultiplexer with latch

74HC/HCT4351

## FUNCTION TABLE

INPUTS						CHANNEL ON
$\bar{E}_1$	$E_2$	$\bar{LE}$	$S_2$	$S_1$	$S_0$	
H	X	X	X	X	X	none
X	L	X	X	X	X	none
L	H	H	L	L	L	$Y_0$
L	H	H	L	L	H	$Y_1$
L	H	H	L	H	L	$Y_2$
L	H	H	L	H	H	$Y_3$
L	H	H	H	L	L	$Y_4$
L	H	H	H	L	H	$Y_5$
L	H	H	H	H	L	$Y_6$
L	H	H	H	H	H	$Y_7$
L	H	L	X	X	X	(1)
X	X	↓	X	X	X	(2)

### Notes

1. Last selected channel "ON".
2. Selected channels latched.
3. H = HIGH voltage level  
L = LOW voltage level  
X = don't care  
↓ = HIGH-to-LOW  $\bar{LE}$  transition

### APPLICATIONS

- Analog multiplexing and demultiplexing
- Digital multiplexing and demultiplexing
- Signal gating

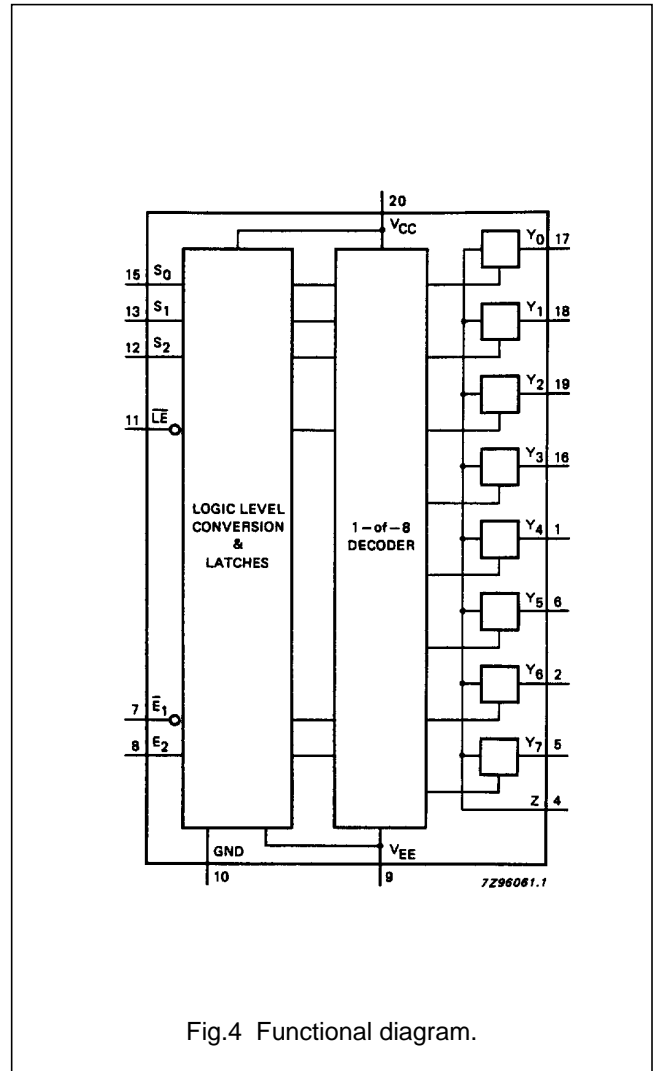

Fig.4 Functional diagram.

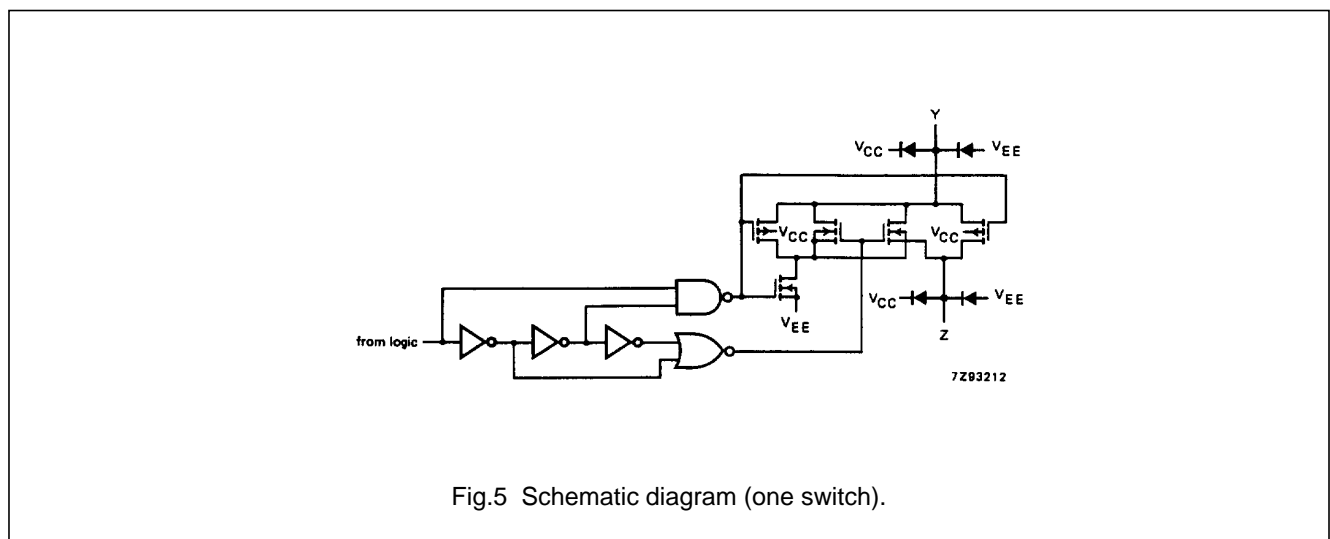

Fig.5 Schematic diagram (one switch).

# 8-channel analog multiplexer/demultiplexer with latch

74HC/HCT4351

## RATINGS

Limiting values in accordance with the Absolute Maximum System (IEC 134)

Voltages are referenced to  $V_{EE} = \text{GND}$  (ground = 0 V)

SYMBOL	PARAMETER	MIN.	MAX.	UNIT	CONDITIONS
$V_{CC}$	DC supply voltage	-0.5	+11.0	V	
$\pm I_{IK}$	DC digital input diode current		20	mA	for $V_I < -0.5 \text{ V}$ or $V_I > V_{CC} + 0.5 \text{ V}$
$\pm I_{SK}$	DC switch diode current		20	mA	for $V_S < -0.5 \text{ V}$ or $V_S > V_{CC} + 0.5 \text{ V}$
$\pm I_S$	DC switch current		25	mA	for $-0.5 \text{ V} < V_S < V_{CC} + 0.5 \text{ V}$
$\pm I_{EE}$	DC $V_{EE}$ current		20	mA	
$\pm I_{CC}; \pm I_{GND}$	DC $V_{CC}$ or GND current		50	mA	
$T_{stg}$	storage temperature range	-65	+150	°C	
$P_{tot}$	power dissipation per package				for temperature range: -40 to +125 °C 74HC/HCT
	plastic DIL		750	mW	above +70 °C: derate linearly with 12 mW/K
	plastic mini-pack (SO)		500	mW	above +70 °C: derate linearly with 8 mW/K
$P_S$	power dissipation per switch		100	mW	

### Note to ratings

- To avoid drawing  $V_{CC}$  current out of terminal Z, when switch current flows in terminals  $Y_n$ , the voltage drop across the bidirectional switch must not exceed 0.4 V. If the switch current flows into terminal Z, no  $V_{CC}$  current will flow out of terminals  $Y_n$ . In this case there is no limit for the voltage drop across the switch, but the voltages at  $Y_n$  and Z may not exceed  $V_{CC}$  or  $V_{EE}$ .

## RECOMMENDED OPERATING CONDITIONS

SYMBOL	PARAMETER	74HC			74HCT			UNIT	CONDITIONS
		min.	typ.	max.	min.	typ.	max.		
$V_{CC}$	DC supply voltage $V_{CC}-\text{GND}$	2.0	5.0	10.0	4.5	5.0	5.5	V	see Figs 6 and 7
$V_{CC}$	DC supply voltage $V_{CC}-V_{EE}$	2.0	5.0	10.0	2.0	5.0	10.0	V	see Figs 6 and 7
$V_I$	DC input voltage range	GND		$V_{CC}$	GND		$V_{CC}$	V	
$V_S$	DC switch voltage range	$V_{EE}$		$V_{CC}$	$V_{EE}$		$V_{CC}$	V	
$T_{amb}$	operating ambient temperature range	-40		+85	-40		+85	°C	see DC and AC CHARACTERISTICS
$T_{amb}$	operating ambient temperature range	-40		+125	-40		+125	°C	
$t_r, t_f$	input rise and fall times		6.0	1000 500 400 250		6.0	500	ns	$V_{CC} = 2.0 \text{ V}$ $V_{CC} = 4.5 \text{ V}$ $V_{CC} = 6.0 \text{ V}$ $V_{CC} = 10.0 \text{ V}$

# 8-channel analog multiplexer/demultiplexer with latch

74HC/HCT4351

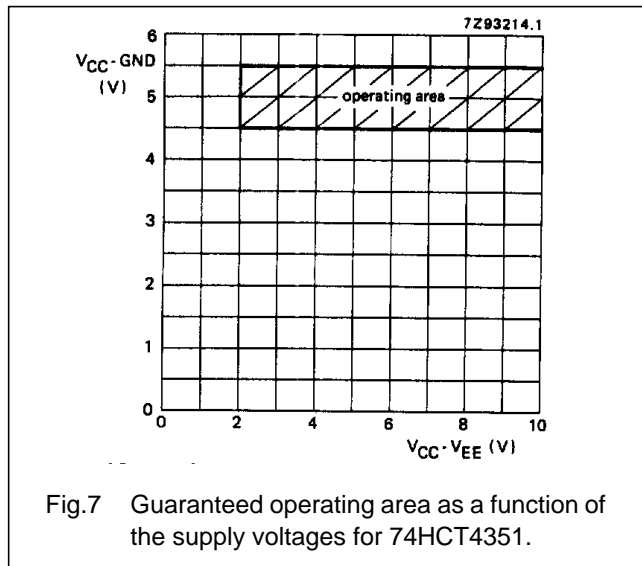
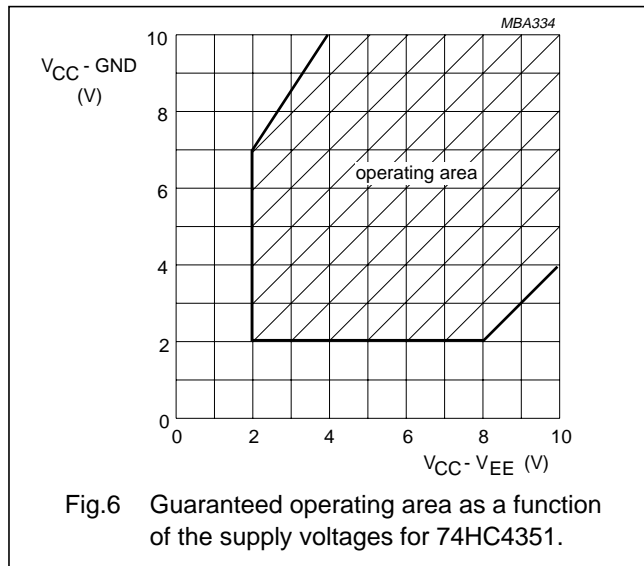

### DC CHARACTERISTICS FOR 74HC/HCT

For 74HC:  $V_{CC} - GND$  or  $V_{CC} - V_{EE} = 2.0, 4.5, 6.0$  and  $9.0$  V

For 74HCT:  $V_{CC} - GND = 4.5$  and  $5.5$  V;  $V_{CC} - V_{EE} = 2.0, 4.5, 6.0$  and  $9.0$  V

SYMBOL	PARAMETER	$T_{amb}$ (°C)						UNIT	TEST CONDITIONS					
		74HC/HCT							$V_{CC}$ (V)	$V_{EE}$ (V)	$I_s$ (µA)	$V_{is}$	$V_i$	
		+25			-40 to +85		-40 to +125							
		min.	typ.	max.	min.	max.	min.							max.
$R_{ON}$	ON resistance (rail)		-	-		-		-	Ω	2.0	0	100	$V_{CC}$ to $V_{EE}$	$V_{IH}$ or $V_{IL}$
			100	180		225		270	Ω	4.5	0	1000		
			90	160		200		240	Ω	6.0	0	1000		
			70	130		165		195	Ω	4.5	-4.5	1000		
$R_{ON}$	ON resistance (rail)		150	-		-		-	Ω	2.0	0	100	$V_{EE}$	$V_{IH}$ or $V_{IL}$
			80	140		175		210	Ω	4.5	0	1000		
			70	120		150		180	Ω	6.0	0	1000		
			60	105		130		160	Ω	4.5	-4.5	1000		
$R_{ON}$	ON resistance (rail)		150	-		-		-	Ω	2.0	0	100	$V_{CC}$	$V_{IH}$ or $V_{IL}$
			90	160		200		240	Ω	4.5	0	1000		
			80	140		175		210	Ω	6.0	0	1000		
			65	120		150		180	Ω	4.5	-4.5	1000		
$\Delta R_{ON}$	maximum $\Delta$ ON resistance between any two channels		-						Ω	2.0	0		$V_{CC}$ to $V_{EE}$	$V_{IH}$ or $V_{IL}$
			9						Ω	4.5	0			
			8						Ω	6.0	0			
			6						Ω	4.5	-4.5			

### Notes to DC characteristics

- At supply voltages ( $V_{CC} - V_{EE}$ ) approaching 2.0 V, the analog switch ON-resistance becomes extremely non-linear. There it is recommended that these devices be used to transmit digital signals only, when using these supply voltages.
- For test circuit measuring  $R_{ON}$  see Fig.8.

# 8-channel analog multiplexer/demultiplexer with latch

74HC/HCT4351

**DC CHARACTERISTICS FOR 74HC**

Voltages are referenced to GND (ground = 0 V)

SYMBOL	PARAMETER	T <sub>amb</sub> (°C)						UNIT	TEST CONDITIONS				
		74HC							V <sub>CC</sub> (V)	V <sub>EE</sub> (V)	V <sub>I</sub>	OTHER	
		+25			-40 to +85		-40 to +125						
		min.	typ.	max.	min.	max.	min.						max.
V <sub>IH</sub>	HIGH level input voltage	1.5 3.15 4.2 6.3	1.2 2.4 3.2 4.7		1.5 3.15 4.2 6.3		1.5 3.15 4.2 6.3	V	2.0 4.5 6.0 9.0				
V <sub>IL</sub>	LOW level input voltage		0.8 2.1 2.8 4.3	0.5 1.35 1.8 2.7		0.5 1.35 1.8 2.7		0.5 1.35 1.8 2.7	V	2.0 4.5 6.0 9.0			
±I <sub>I</sub>	input leakage current			0.1 0.2		1.0 2.0		1.0 2.0	µA	6.0 10.0	0 0	V <sub>CC</sub> or GND	
±I <sub>S</sub>	analog switch OFF-state current per channel			0.1		1.0		1.0	µA	10.0	0	V <sub>IH</sub> or V <sub>IL</sub>	I <sub>S</sub>   = V <sub>CC</sub> - V <sub>EE</sub> (see Fig.10)
±I <sub>S</sub>	analog switch OFF-state current all channels			0.4		4.0		4.0	µA	10.0	0	V <sub>IH</sub> or V <sub>IL</sub>	I <sub>S</sub>   = V <sub>CC</sub> - V <sub>EE</sub> (see Fig.10)
±I <sub>S</sub>	analog switch ON-state current			0.4		4.0		4.0	µA	10.0	0	V <sub>IH</sub> or V <sub>IL</sub>	I <sub>S</sub>   = V <sub>CC</sub> - V <sub>EE</sub> (see Fig.11)
I <sub>CC</sub>	quiescent supply current			8.0 16.0		80.0 160.0		160.0 320.0	µA	6.0 10.0	0 0	V <sub>CC</sub> or GND	V <sub>is</sub> = V <sub>EE</sub> or V <sub>CC</sub> ; V <sub>os</sub> = V <sub>CC</sub> or V <sub>EE</sub>

# 8-channel analog multiplexer/demultiplexer with latch

74HC/HCT4351

**AC CHARACTERISTICS FOR 74HC**GND = 0 V;  $t_r = t_f = 6$  ns;  $C_L = 50$  pF

SYMBOL	PARAMETER	$T_{amb}$ (°C)						UNIT	TEST CONDITIONS			
		74HC							$V_{CC}$ (V)	$V_{EE}$ (V)	OTHER	
		+25			-40 to +85		-40 to +125					
		min.	typ.	max.	min.	max.	min.		max.			
$t_{PHL}/t_{PLH}$	propagation delay $V_{is}$ to $V_{os}$		14 5 4 4	60 12 10 8		75 15 13 10		90 18 15 12	ns	2.0 4.5 6.0 4.5	0 0 0 -4.5	$R_L = \infty$ ; $C_L = 50$ pF (see Fig.17)
$t_{PZH}/t_{PZL}$	turn "ON" time $\bar{E}_1$ to $V_{os}$		85 31 25 28	300 60 51 55		375 75 64 69		450 90 77 83	ns	2.0 4.5 6.0 4.5	0 0 0 -4.5	$R_L = 1$ k $\Omega$ ; $C_L = 50$ pF (see Fig.18)
$t_{PZH}/t_{PZL}$	turn "ON" time $E_2$ to $V_{os}$		85 31 25 25	300 60 51 55		375 75 64 69		450 90 77 83	ns	2.0 4.5 6.0 4.5	0 0 0 -4.5	$R_L = 1$ k $\Omega$ ; $C_L = 50$ pF (see Fig.18)
$t_{PZH}/t_{PZL}$	turn "ON" time $\bar{LE}$ to $V_{os}$		91 33 26 27	300 60 51 55		375 75 64 69		450 90 77 83	ns	2.0 4.5 6.0 4.5	0 0 0 -4.5	$R_L = 1$ k $\Omega$ ; $C_L = 50$ pF (see Fig.18)
$t_{PZH}/t_{PZL}$	turn "ON" time $S_n$ to $V_{os}$		88 32 26 25	300 60 51 50		375 75 64 63		450 90 77 75	ns	2.0 4.5 6.0 4.5	0 0 0 -4.5	$R_L = 1$ k $\Omega$ ; $C_L = 50$ pF (see Fig.18)
$t_{PHZ}/t_{PLZ}$	turn "OFF" time $\bar{E}_1$ to $V_{os}$		69 25 20 20	250 50 43 40		315 63 54 50		375 75 64 60	ns	2.0 4.5 6.0 4.5	0 0 0 -4.5	$R_L = 1$ k $\Omega$ ; $C_L = 50$ pF (see Fig.18)
$t_{PHZ}/t_{PLZ}$	turn "OFF" time $E_2$ to $V_{os}$		72 26 21 19	250 50 43 40		315 63 54 50		375 75 64 60	ns	2.0 4.5 6.0 4.5	0 0 0 -4.5	$R_L = 1$ k $\Omega$ ; $C_L = 50$ pF (see Fig.18)
$t_{PHZ}/t_{PLZ}$	turn "OFF" time $\bar{LE}$ to $V_{os}$		83 30 24 26	275 55 47 45		345 69 59 56		415 83 71 68	ns	2.0 4.5 6.0 4.5	0 0 0 -4.5	$R_L = 1$ k $\Omega$ ; $C_L = 50$ pF (see Fig.18)
$t_{PHZ}/t_{PLZ}$	turn "OFF" time $S_n$ to $V_{os}$		80 29 23 24	275 55 47 48		345 69 59 60		415 83 71 72	ns	2.0 4.5 6.0 4.5	0 0 0 -4.5	$R_L = 1$ k $\Omega$ ; $C_L = 50$ pF (see Fig.18)

8-channel analog multiplexer/demultiplexer  
with latch

74HC/HCT4351

SYMBOL	PARAMETER	T <sub>amb</sub> (°C)							UNIT	TEST CONDITIONS		
		74HC								V <sub>CC</sub> (V)	V <sub>EE</sub> (V)	OTHER
		+25			-40 to +85		-40 to +125					
		min.	typ.	max.	min.	max.	min.	max.				
t <sub>su</sub>	set-up time S <sub>n</sub> to $\overline{\text{LE}}$	60	17			75		90	ns	2.0	0	R <sub>L</sub> = 1 kΩ; C <sub>L</sub> = 50 pF (see Fig.19)
		12	6			15		18				
		10	5			13		15				
		18	9			23		27				
t <sub>h</sub>	hold time S <sub>n</sub> to $\overline{\text{LE}}$	5	-8			5		5	ns	2.0	0	R <sub>L</sub> = 1 kΩ; C <sub>L</sub> = 50 pF (see Fig.19)
		5	-3			5		5				
		5	-2			5		5				
		5	-4			5		5				
t <sub>w</sub>	$\overline{\text{LE}}$ minimum pulse width HIGH	100	11			125		150	ns	2.0	0	R <sub>L</sub> = 1 kΩ; C <sub>L</sub> = 50 pF (see Fig.19)
		20	1			25		30				
		17	3			21		26				
		25	7			31		38				

# 8-channel analog multiplexer/demultiplexer with latch

74HC/HCT4351

**DC CHARACTERISTICS FOR 74HCT**

Voltages are referenced to GND (ground = 0)

SYMBOL	PARAMETER	T <sub>amb</sub> (°C)							UNIT	TEST CONDITIONS			
		74HCT								V <sub>CC</sub> (V)	V <sub>EE</sub> (V)	V <sub>I</sub>	OTHER
		+25			-40 to +85		-40 to +125						
		min.	typ.	max.	min.	max.	min.	max.					
V <sub>IH</sub>	HIGH level input voltage	2.0	1.6		2.0		2.0		V	4.5 to 5.5			
V <sub>IL</sub>	LOW level input voltage		1.2	0.8		0.8		0.8	V	4.5 to 5.5			
±I <sub>I</sub>	input leakage current			0.1		1.0		1.0	μA	5.5	0	V <sub>CC</sub> or GND	
±I <sub>S</sub>	analog switch OFF-state current per channel			0.1		1.0		1.0	μA	10.0	0	V <sub>IH</sub> or V <sub>IL</sub>	M <sub>S</sub>   = V <sub>CC</sub> - V <sub>EE</sub> (see Fig.10)
±I <sub>S</sub>	analog switch OFF-state current all channels			0.4		4.0		4.0	μA	10.0	0	V <sub>IH</sub> or V <sub>IL</sub>	M <sub>S</sub>   = V <sub>CC</sub> - V <sub>EE</sub> (see Fig.10)
±I <sub>S</sub>	analog switch ON-state current			0.4		4.0		4.0	μA	10.0	0	V <sub>IH</sub> or V <sub>IL</sub>	M <sub>S</sub>   = V <sub>CC</sub> - V <sub>EE</sub> (see Fig.11)
I <sub>CC</sub>	quiescent supply current			8.0 16.0		80.0 160.0		160.0 320.0	μA	5.5 5.0	0 -5.0	V <sub>CC</sub> or GND	V <sub>is</sub> = V <sub>EE</sub> or V <sub>CC</sub> ; V <sub>os</sub> = V <sub>CC</sub> or V <sub>EE</sub>
ΔI <sub>CC</sub>	additional quiescent supply current per input pin for unit load coefficient is 1 (note 1)		100	360		450		490	μA	4.5 to 5.5	0	V <sub>CC</sub> -2.1 V	other inputs at V <sub>CC</sub> or GND

**Note to HCT types**

- The value of additional quiescent supply current (ΔI<sub>CC</sub>) for a unit load of 1 is given here. To determine ΔI<sub>CC</sub> per input, multiply this value by the unit load coefficient shown in the table below.

INPUT	UNIT LOAD COEFFICIENT
$\overline{E}_1, E_2$	0.50
$S_n$	0.50
$\overline{LE}$	1.5

# 8-channel analog multiplexer/demultiplexer with latch

74HC/HCT4351

**AC CHARACTERISTICS FOR 74HCT**GND = 0 V;  $t_r = t_f = 6$  ns;  $C_L = 50$  pF

SYMBOL	PARAMETER	$T_{amb}$ (°C)						UNIT	TEST CONDITIONS			
		74HCT							$V_{CC}$ (V)	$V_{EE}$ (V)	OTHER	
		+25			-40 to +85		-40 to +125					
		min.	typ.	max.	min.	max.	min.		max.			
$t_{PHL}/t_{PLH}$	propagation delay $V_{is}$ to $V_{os}$		6 4	12 8		15 10		18 12	ns	4.5 4.5	0 -4.5	$R_L = \infty$ ; $C_L = 50$ pF (see Fig.17)
$t_{PZH}/t_{PZL}$	turn "ON" time $\bar{E}_1$ to $V_{os}$		40 31	75 60		94 75		113 90	ns	4.5 4.5	0 -4.5	$R_L = 1$ k $\Omega$ ; $C_L = 50$ pF (see Fig.18)
$t_{PZH}/t_{PZL}$	turn "ON" time $E_2$ to $V_{os}$		35 26	70 50		88 63		105 75	ns	4.5 4.5	0 -4.5	$R_L = 1$ k $\Omega$ ; $C_L = 50$ pF (see Fig.18)
$t_{PZH}/t_{PZL}$	turn "ON" time $\bar{LE}$ to $V_{os}$		42 37	75 60		94 75		113 90	ns	4.5 4.5	0 -4.5	$R_L = 1$ k $\Omega$ ; $C_L = 50$ pF (see Fig.18)
$t_{PZH}/t_{PZL}$	turn "ON" time $S_n$ to $V_{os}$		39 30	75 60		94 75		113 90	ns	4.5 4.5	0 -4.5	$R_L = 1$ k $\Omega$ ; $C_L = 50$ pF (see Fig.18)
$t_{PHZ}/t_{PLZ}$	turn "OFF" time $\bar{E}_1$ to $V_{os}$		27 20	55 40		69 50		83 60	ns	4.5 4.5	0 -4.5	$R_L = 1$ k $\Omega$ ; $C_L = 50$ pF (see Fig.18)
$t_{PHZ}/t_{PLZ}$	turn "OFF" time $E_2$ to $V_{os}$		32 26	60 50		75 63		90 75	ns	4.5 4.5	0 -4.5	$R_L = 1$ k $\Omega$ ; $C_L = 50$ pF (see Fig.18)
$t_{PHZ}/t_{PLZ}$	turn "OFF" time $\bar{LE}$ to $V_{os}$		33 30	60 55		75 69		90 83	ns	4.5 4.5	0 -4.5	$R_L = 1$ k $\Omega$ ; $C_L = 50$ pF (see Fig.18)
$t_{PHZ}/t_{PLZ}$	turn "OFF" time $S_n$ to $V_{os}$		33 29	65 55		81 69		98 83	ns	4.5 4.5	0 -4.5	$R_L = 1$ k $\Omega$ ; $C_L = 50$ pF (see Fig.18)
$t_{su}$	set-up time $S_n$ to $\bar{LE}$	12 14	6 7			15 18		18 21	ns	4.5 4.5	0 -4.5	$R_L = 1$ k $\Omega$ ; $C_L = 50$ pF (see Fig.19)
$t_h$	hold time $S_n$ to $\bar{LE}$	5 5	-1 -2			5 5		5 5	ns	4.5 4.5	0 -4.5	$R_L = 1$ k $\Omega$ ; $C_L = 50$ pF (see Fig.19)
$t_w$	$\bar{LE}$ minimum pulse width HIGH	25 25	13 13			31 31		38 38	ns	4.5 4.5	0 -4.5	$R_L = 1$ k $\Omega$ ; $C_L = 50$ pF (see Fig.19)

# 8-channel analog multiplexer/demultiplexer with latch

## 74HC/HCT4351

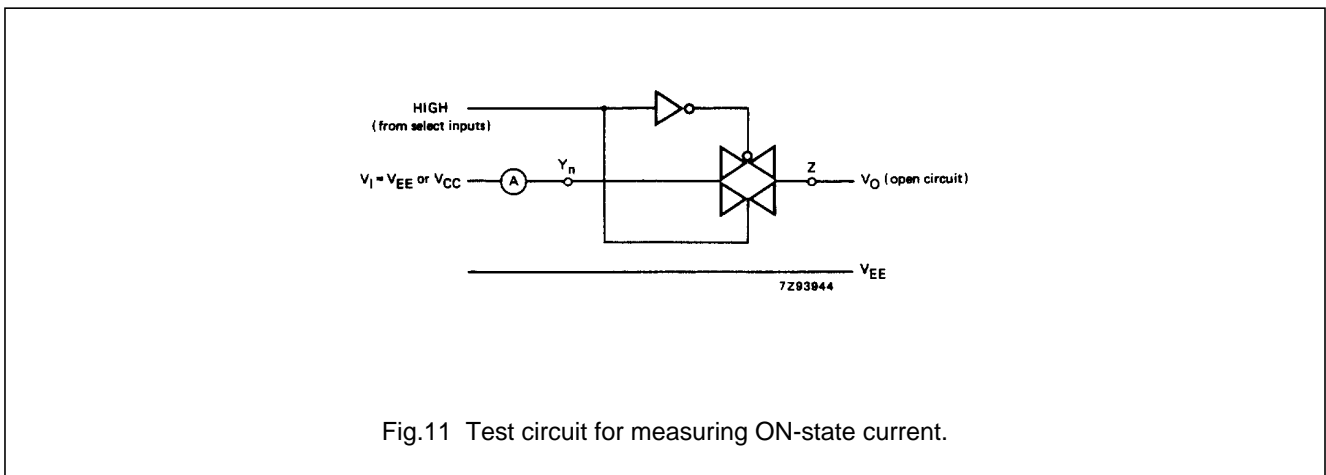
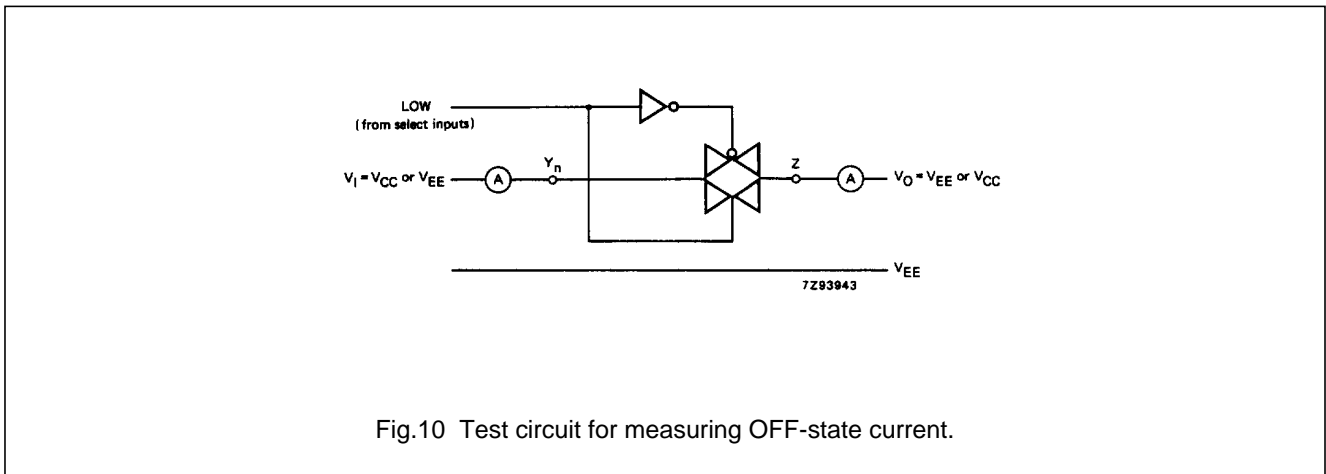
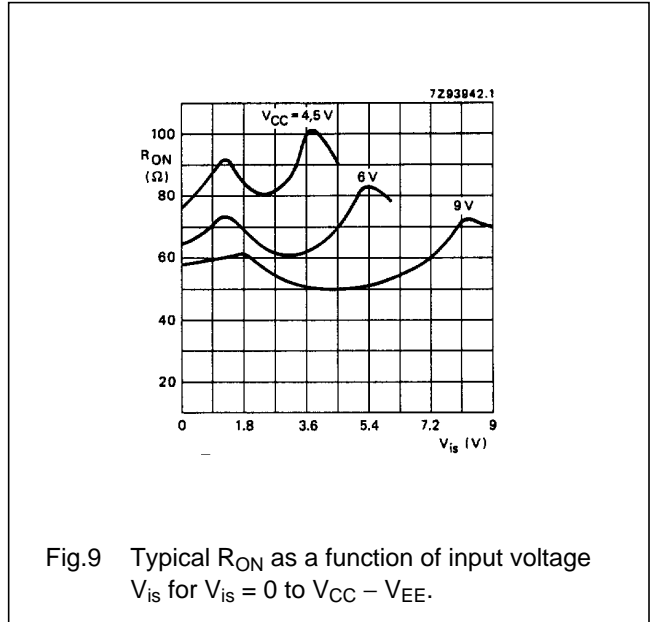
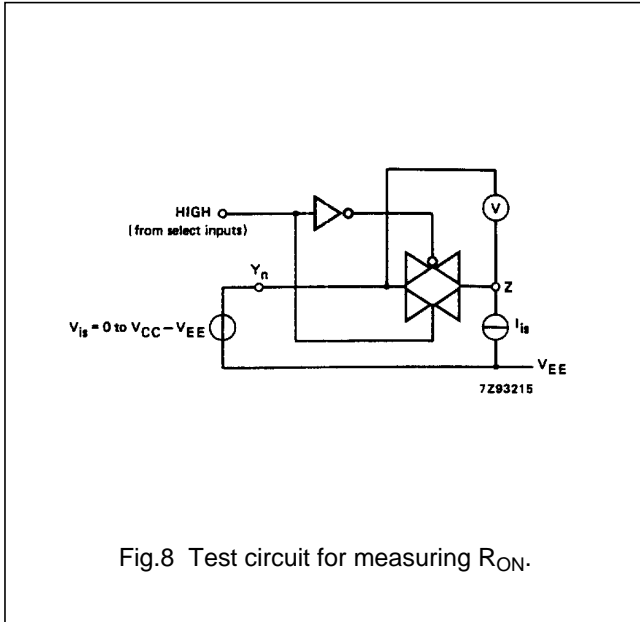

# 8-channel analog multiplexer/demultiplexer with latch

74HC/HCT4351

## ADDITIONAL AC CHARACTERISTICS FOR 74HC/HCT

### Recommended conditions and typical values

GND = 0 V;  $T_{amb} = 25\text{ }^{\circ}\text{C}$ 

SYMBOL	PARAMETER	typ.	UNIT	$V_{CC}$ (V)	$V_{EE}$ (V)	$V_{is(p-p)}$ (V)	CONDITIONS
	sine-wave distortion $f = 1\text{ kHz}$	0.04 0.02	% %	2.25 4.5	-2.25 -4.5	4.0 8.0	$R_L = 10\text{ k}\Omega$ ; $C_L = 50\text{ pF}$ (see Fig.14)
	sine-wave distortion $f = 10\text{ kHz}$	0.12 0.06	% %	2.25 4.5	-2.25 -4.5	4.0 8.0	$R_L = 10\text{ k}\Omega$ ; $C_L = 50\text{ pF}$ (see Fig.14)
	switch "OFF" signal feed-through	-50 -50	dB dB	2.25 4.5	-2.25 -4.5	note 1	$R_L = 600\text{ }\Omega$ ; $C_L = 50\text{ pF}$ (see Figs 12 and 15)
$V_{(p-p)}$	crosstalk voltage between control and any switch (peak-to-peak value)	120 220	mV mV	4.5 4.5	0 -4.5		$R_L = 600\text{ }\Omega$ ; $C_L = 50\text{ pF}$ ; $f = 1\text{ MHz}$ ( $E_1$ , $E_2$ or $S_n$ , square-wave between $V_{CC}$ and GND, $t_r = t_f = 6\text{ ns}$ ) (see Fig.16)
$f_{max}$	minimum frequency response (-3dB)	160 170	MHz MHz	2.25 4.5	-2.25 -4.5	note 2	$R_L = 50\text{ }\Omega$ ; $C_L = 10\text{ pF}$ (see Figs 13 and 14)
$C_S$	maximum switch capacitance independent (Y) common (Z)	5 25	pF pF				

### Notes to AC characteristics

- Adjust input voltage  $V_{is}$  to 0 dBm level (0 dBm = 1 mW into 600  $\Omega$ ).
- Adjust input voltage  $V_{is}$  to 0 dBm level at  $V_{os}$  for 1 MHz (0 dBm = 1 mW into 50  $\Omega$ ).

$V_{is}$  is the input voltage at a  $Y_n$  or Z terminal, whichever is assigned as an input.

$V_{os}$  is the output voltage at a  $Y_n$  or Z terminal, whichever is assigned as an output.

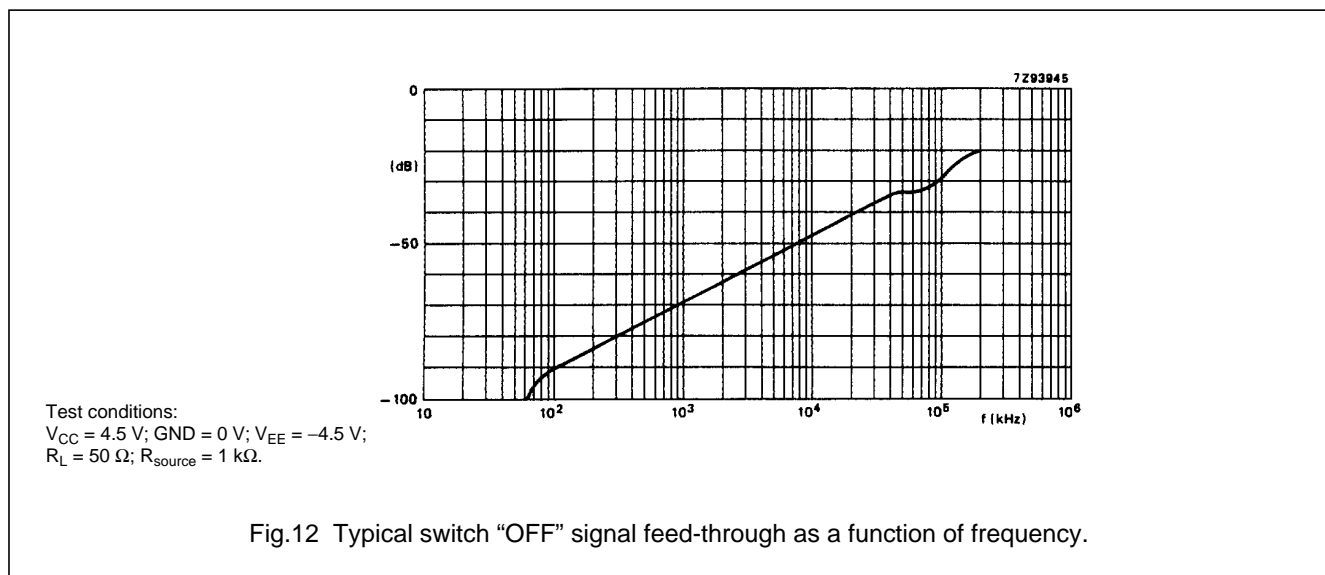

# 8-channel analog multiplexer/demultiplexer with latch

74HC/HCT4351

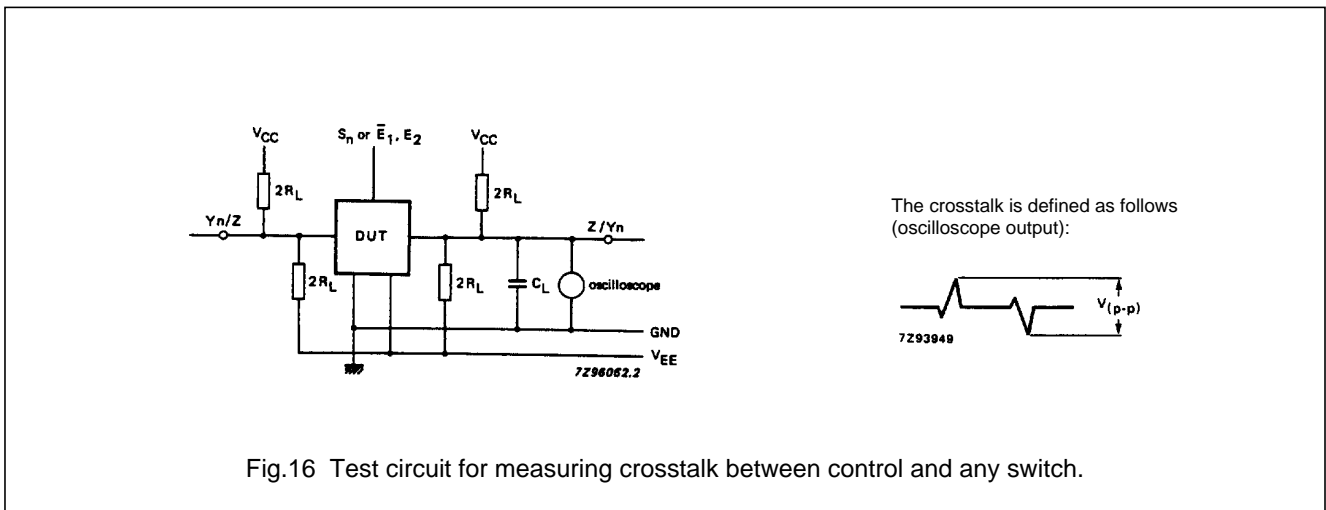
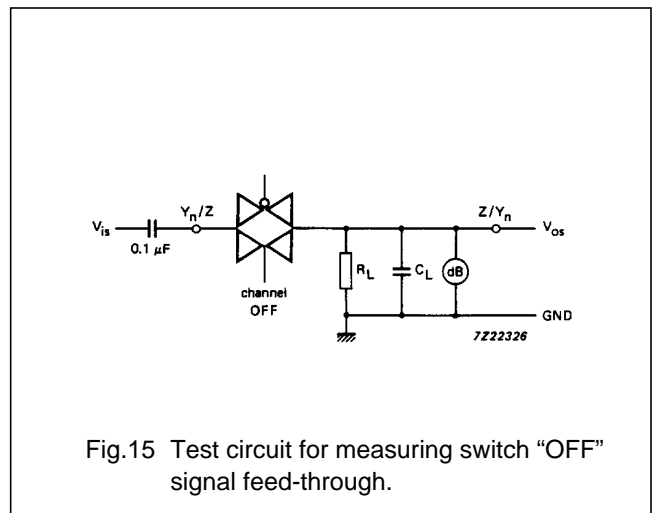
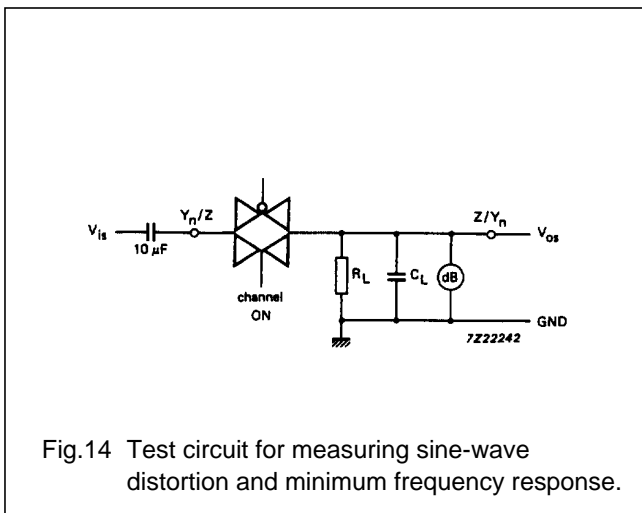
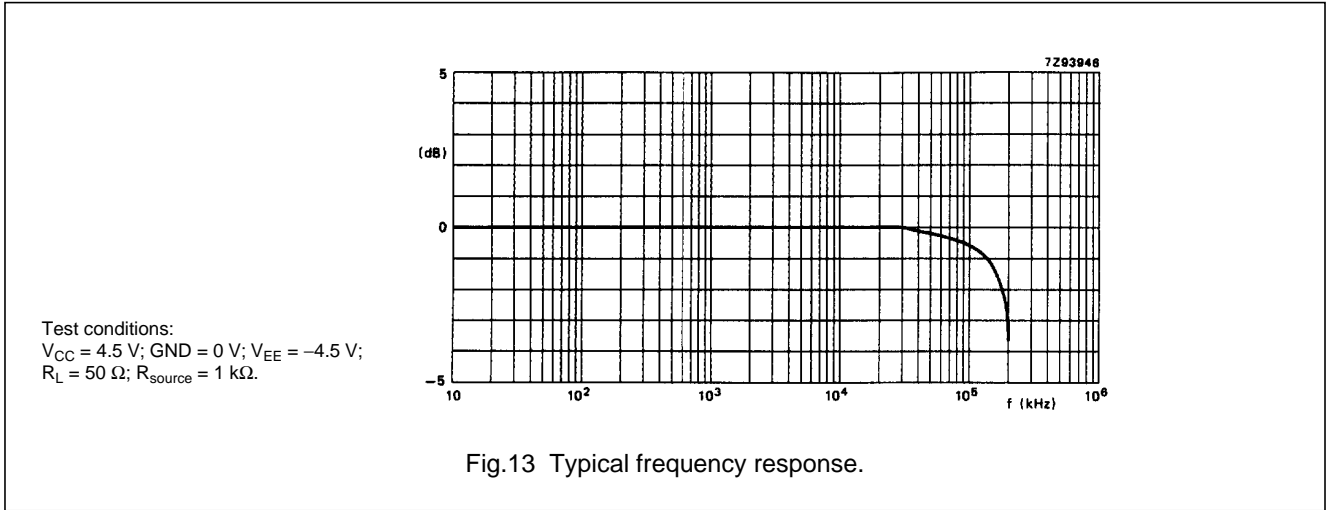

# 8-channel analog multiplexer/demultiplexer with latch

74HC/HCT4351

## AC WAVEFORMS

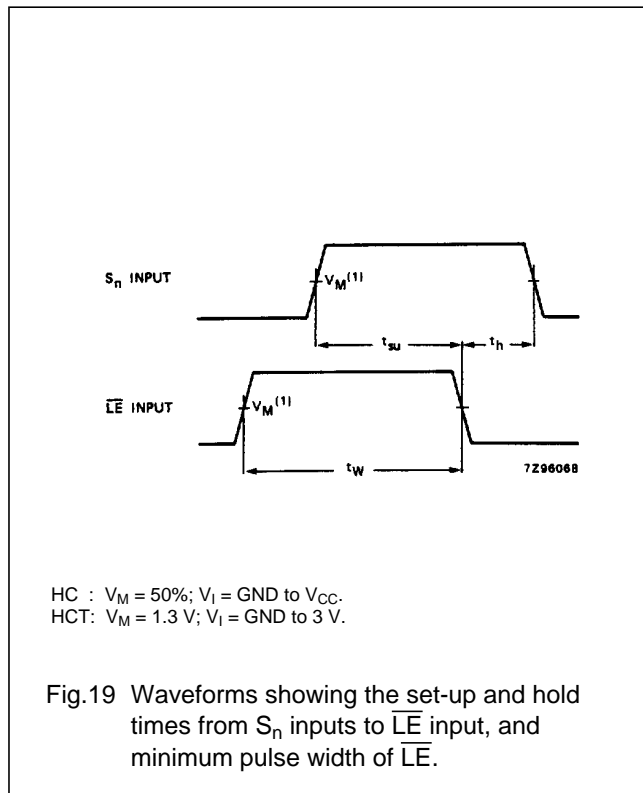
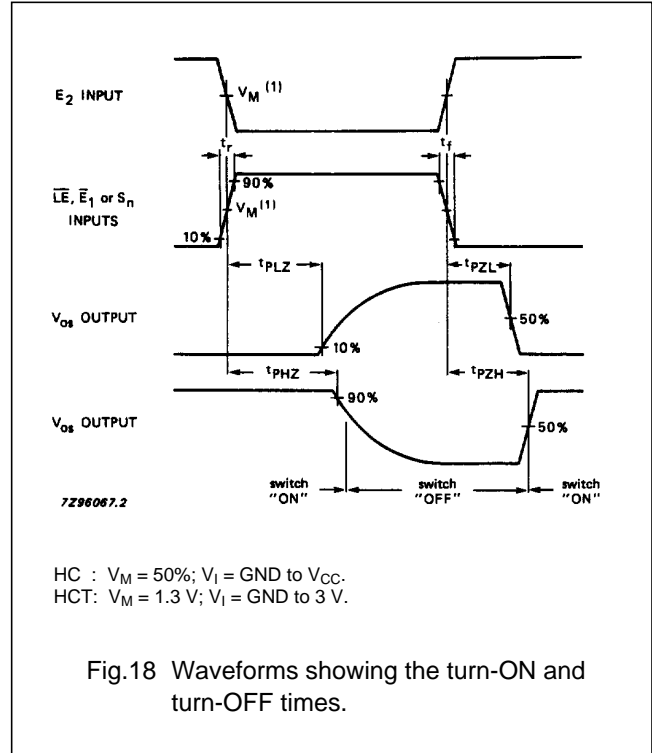
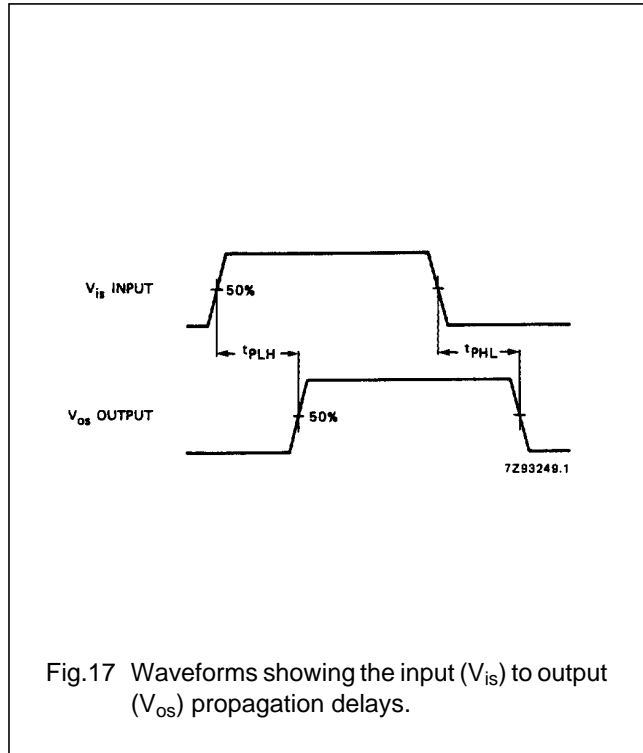

HC :  $V_M = 50\%$ ;  $V_I = \text{GND to } V_{CC}$ .  
 HCT:  $V_M = 1.3 \text{ V}$ ;  $V_I = \text{GND to } 3 \text{ V}$ .

# 8-channel analog multiplexer/demultiplexer with latch

74HC/HCT4351

## TEST CIRCUIT AND WAVEFORMS

**Conditions**

TEST	SWITCH	V <sub>is</sub>
t <sub>PZH</sub>	V <sub>EE</sub>	V <sub>CC</sub>
t <sub>PZL</sub>	V <sub>CC</sub>	V <sub>EE</sub>
t <sub>PHZ</sub>	V <sub>EE</sub>	V <sub>CC</sub>
t <sub>PLZ</sub>	V <sub>CC</sub>	V <sub>EE</sub>
others	open	pulse

7293951

FAMILY	AMPLITUDE	V <sub>M</sub>	t <sub>r</sub> ; t <sub>f</sub>	
			f <sub>max</sub> ; PULSE WIDTH	OTHER
74HC	V <sub>CC</sub>	50%	< 2 ns	6 ns
74HCT	3.0 V	1.3 V	< 2 ns	6 ns

C<sub>L</sub> = load capacitance including jig and probe capacitance (see AC CHARACTERISTICS for values).  
 R<sub>T</sub> = termination resistance should be equal to the output impedance Z<sub>O</sub> of the pulse generator.  
 t<sub>r</sub> = t<sub>f</sub> = 6 ns; when measuring f<sub>max</sub>, there is no constraint on t<sub>r</sub>, t<sub>f</sub> with 50% duty factor.

Fig.20 Test circuit for measuring AC performance.

**Conditions**

TEST	SWITCH	V <sub>is</sub>
t <sub>PZH</sub>	V <sub>EE</sub>	V <sub>CC</sub>
t <sub>PZL</sub>	V <sub>CC</sub>	V <sub>EE</sub>
t <sub>PHZ</sub>	V <sub>EE</sub>	V <sub>CC</sub>
t <sub>PLZ</sub>	V <sub>CC</sub>	V <sub>EE</sub>
others	open	pulse

7287478.3

FAMILY	AMPLITUDE	V <sub>M</sub>	t <sub>r</sub> ; t <sub>f</sub>	
			f <sub>max</sub> ; PULSE WIDTH	OTHER
74HC	V <sub>CC</sub>	50%	< 2 ns	6 ns
74HCT	3.0 V	1.3 V	< 2 ns	6 ns

C<sub>L</sub> = load capacitance including jig and probe capacitance (see AC CHARACTERISTICS for values).  
 R<sub>T</sub> = termination resistance should be equal to the output impedance Z<sub>O</sub> of the pulse generator.  
 t<sub>r</sub> = t<sub>f</sub> = 6 ns; when measuring f<sub>max</sub>, there is no constraint on t<sub>r</sub>, t<sub>f</sub> with 50% duty factor.

Fig.21 Input pulse definitions.

---

8-channel analog multiplexer/demultiplexer  
with latch

---



74HC/HCT4351

**PACKAGE OUTLINES**

See *"74HC/HCT/HCU/HCMOS Logic Package Outlines"*.

## Looking for pricing, stock, or lifecycle information?

Click below to explore more details on WIN SOURCE:

-  [View 74HCT4351N,112 on WIN SOURCE](#)
-  [NXP / Nexperia Information](#)

## Optimize Your Supply Chain with WIN SOURCE Solutions

-  Global Sourcing Solution
-  Obsolete Management
-  Cost Control Management
-  Shortage Management
-  Alternative Solution
-  Excess Inventory Management