



**THE DATASHEET OF**  
**8413S12BKILF**



## General Description

The 8413S12B is a PLL-based clock generator. This high performance device is optimized to generate the processor core reference clock, the PCI-Express, sRIO, XAUI, SerDes reference clocks and the clocks for both the Gigabit Ethernet MAC and PHY. The clock generator offers ultra low-jitter, low-skew clock outputs. The output frequencies are generated from a 25MHz external input source or an external 25MHz parallel resonant crystal. The industrial temperature range of the 8413S12B supports telecommunication, networking, and storage requirements.

## Applications

- CPE Gateway Design
- Home Media Servers
- 802.11n AP or Gateway
- Soho Secure Gateway
- Soho SME Gateway
- Wireless Soho and SME VPN Solutions
- Wired and Wireless Network Security
- Web Servers and Exchange Servers

## Pin Assignment

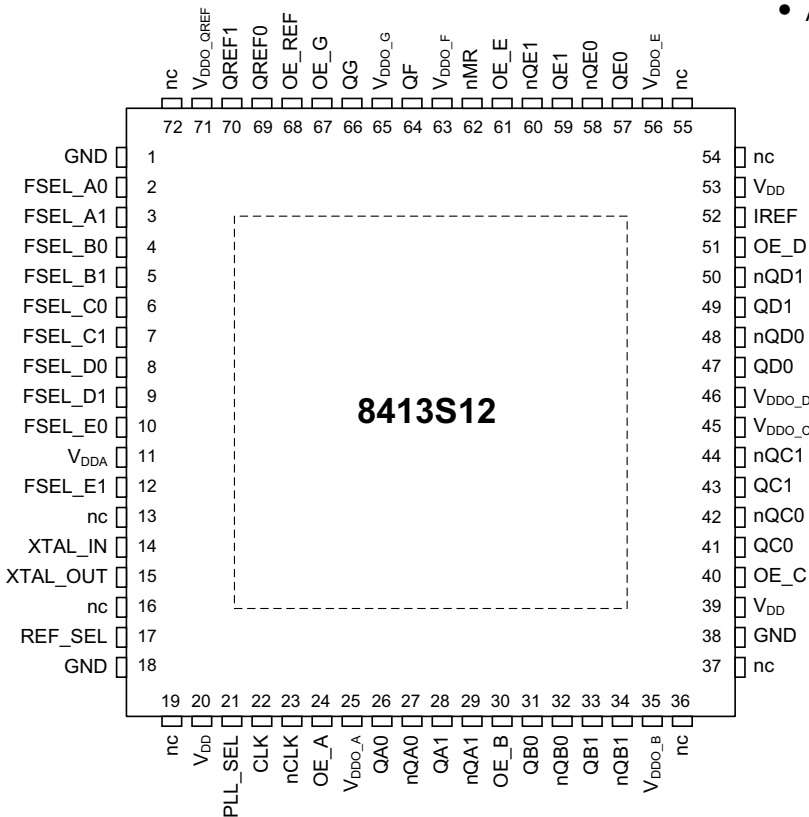

72-pin, 10mm x 10mm LQFP Package

## Features

- Ten selectable 100MHz, 125MHz, 156.25MHz and 312.5MHz clocks for PCI Express, sRIO and GbE, HCSL interface levels
- One single-ended QG LVCMOS/LVTTL clock output at 125MHz
- One single-ended QF LVCMOS/LVTTL clock output at 50MHz, 15Ω output impedance
- Two single-ended QREFx LVCMOS/LVTTL outputs at 25MHz, 15Ω output impedance
- Selectable external crystal or differential (single-ended) input source
- Crystal oscillator interface designed for 25MHz, parallel resonant crystal
- Differential CLK, nCLK input pair that can accept: LVPECL, LVDS, LVHSTL, HCSL input levels
- Internal resistor bias on nCLK pin allows the user to drive CLK input with external single-ended (LVCMOS/ LVTTL) input levels
- Supply Modes, (125MHz QG output and 25MHz QREFx outputs):

Core / Output  
3.3V / 3.3V  
3.3V / 2.5V

- Supply Modes, (HCSL outputs, and 50MHz QF output):

Core / Output  
3.3V / 3.3V

- -40°C to 85°C ambient operating temperature
- Available in Lead-free (RoHS 6) package

# Block Diagram

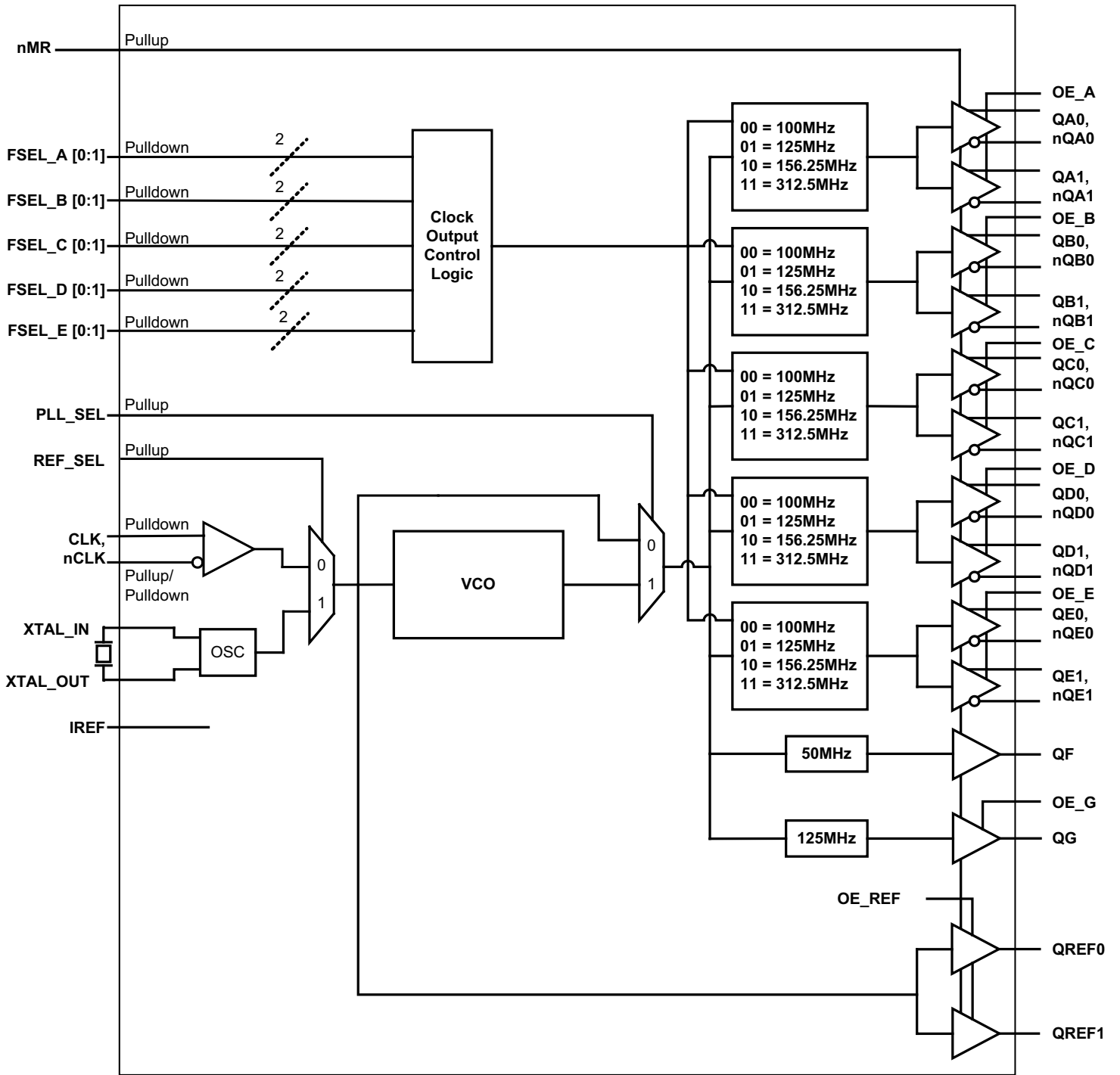

**NOTE:** OE\_[A:G] and OE\_REF pins have pullup resistors.

## Pin Descriptions and Characteristics

Table 1. Pin Descriptions

Number	Name	Type		Description
1, 18, 38	GND	Power		Power supply ground.
2, 3	FSEL_A0, FSEL_A1	Input	Pulldown	Selects the QAx, nQAx output frequency. See Table 3A. LVCMOS/LVTTL interface levels.
4, 5	FSEL_B0, FSEL_B1	Input	Pulldown	Selects the QBx, nQBx output frequency. See Table 3A. LVCMOS/LVTTL interface levels.
6, 7	FSEL_C0, FSEL_C1	Input	Pulldown	Selects the QCx, nQCx output frequency. See Table 3A. LVCMOS/LVTTL interface levels.
8, 9	FSEL_D0, FSEL_D1	Input	Pulldown	Selects the QDx, nQDx output frequency. See Table 3A. LVCMOS/LVTTL interface levels.
10, 12	FSEL_E0, FSEL_E1	Input	Pulldown	Selects the QEx, nQEx output frequency. See Table 3A. LVCMOS/LVTTL interface levels.
11	V <sub>DDA</sub>	Power		Analog supply pin.
13, 16, 19, 36, 37, 54, 55, 72	nc	Unused		No connect.
14, 15	XTAL_IN, XTAL_OUT	Input		Parallel resonant crystal interface. XTAL_OUT is the output, XTAL_IN is the input.
17	REF_SEL	Input	Pullup	Input source control pin. See Table 3C. LVCMOS/LVTTL interface levels.
20, 39, 53	V <sub>DD</sub>	Power		Core supply pins.
21	PLL_SEL	Input	Pullup	PLL bypass control pin. See Table 3B. LVCMOS/LVTTL interface levels.
22	CLK	Input	Pulldown	Non-inverting differential clock input.
23	nCLK	Input	Pullup/ Pulldown	Inverting differential clock input. Internal resistor bias to V <sub>DD</sub> /2.
24	OE_A	Input	Pullup	Active HIGH output enable for Bank A outputs. See Table 3D. LVCMOS/LVTTL interface levels.
25	V <sub>DDO_A</sub>	Power		Bank A (HCSL) output supply pin. 3.3 V supply.
26, 27	QA0, nQA0	Output		Differential output pairs. HCSL interface levels.
28, 29	QA1, nQA1	Output		Differential output pairs. HCSL interface levels.
30	OE_B	Input	Pullup	Active HIGH output enable for Bank B outputs. See Table 3D. LVCMOS/LVTTL interface levels.
31, 32	QB0, nQB0	Output		Differential output pair. HCSL interface levels.
33, 34	QB1, nQB1	Output		Differential output pair. HCSL interface levels.
35	V <sub>DDO_B</sub>	Power		Bank B (HCSL) output supply pin. 3.3V supply.
40	OE_C	Input	Pullup	Active HIGH output enable for Bank C outputs. See Table 3D. LVCMOS/LVTTL interface levels.
41, 42	QC0, nQC0	Output		Differential output pair. HCSL interface levels.
43, 44	QC1, nQC1	Output		Differential output pair. HCSL interface levels.
45	V <sub>DDO_C</sub>	Power		Bank C (HCSL) output supply pin. 3.3V supply.
46	V <sub>DDO_D</sub>	Power		Bank D (HCSL) output and HCSL reference circuit supply pin. Must be connected to 3.3V to use any of the HCSL outputs.
47, 48	QD0, nQD0	Output		Differential output pair. HCSL interface levels.
49, 50	QD1, nQD1	Output		Differential output pair. HCSL interface levels.

**Table 1. Pin Descriptions (Continued)**

Number	Name	Type		Description
51	OE_D	Input	Pullup	Active HIGH output enable for Bank D outputs. See Table 3D. LVCMOS/LVTTL interface levels.
52	I <sub>REF</sub>	Input		External fixed precision resistor (475) from this pin to ground provides a reference current used for differential current-mode Q[Ax:Ex], nQ[Ax:EX] outputs.
56	V <sub>DDO_E</sub>	Power		Bank E (HCSL) output supply pin. 3.3V supply.
57, 58	QE0, nQE0	Output		Differential output pair. HCSL interface levels.
59, 60	QE1, nQE1	Output		Differential output pair. HCSL interface levels.
61	OE_E	Input	Pullup	Active HIGH output enable for Bank E outputs. See Table 3D. LVCMOS/LVTTL interface levels.
62	nMR	Input	Pullup	Active LOW Master Reset. When logic LOW, all outputs are reset causing the true outputs Qx to go low and the inverted outputs nQx to go high. When logic HIGH, all outputs are enabled. LVCMOS/LVTTL interface levels.
63	V <sub>DDO_F</sub>	Power		QF output supply pin (LVCMOS/LVTTL). 3.3V supply.
64	QF	Output		Single-ended output. 3.3V LVCMOS/LVTTL interface levels.
65	V <sub>DDO_G</sub>	Power		QG output supply pins (LVCMOS/LVTTL). 3.3V or 2.5V supply.
66	QG	Output		Single-ended output. 3.3V or 2.5V LVCMOS/LVTTL interface levels.
67	OE_G	Input	Pullup	Active HIGH output enable for Bank G output. See Table 3E. LVCMOS/LVTTL interface levels.
68	OE_REF	Input	Pullup	Active HIGH output enable for QREF[0:1] outputs. See Table 3F. LVCMOS/LVTTL interface levels.
69, 70	QREF0, QREF1	Output		Single-ended REF outputs. 3.3V or 2.5V LVCMOS/LVTTL interface levels.
71	V <sub>DDO_QREF</sub>	Power		QREF[0:1] output supply pin (LVCMOS/LVTTL). 3.3V or 2.5V supply.

NOTE: *Pullup* and *Pulldown* refer to internal input resistors. See Table 2, *Pin Characteristics*, for typical values.

**Table 2. Pin Characteristics**

Symbol	Parameter	Test Conditions	Minimum	Typical	Maximum	Units
C <sub>IN</sub>	Input Capacitance			2		pF
R <sub>PULLUP</sub>	Input Pullup Resistor			51		kΩ
R <sub>PULLDOWN</sub>	Input Pulldown Resistor			51		kΩ
R <sub>OUT</sub>	Output Impedance	QF, QG, QREF[0:1]	V <sub>DDO_F</sub> = V <sub>DDO_G</sub> = V <sub>DDO_QREF</sub> = 3.465V	15		Ω
		QG, QREF[0:1]	V <sub>DDO_QREF</sub> , V <sub>DDO_G</sub> = 2.625V	15		Ω

## Function Tables

**Table 3A. FSEL\_X Control Input Function Table**

Input	Output Frequency
<b>FSEL_X[0:1]</b>	<b>Q[Ax:Ex], nQ[Ax:Ex]</b>
00 (default)	100MHz
01	125MHz
10	156.25MHz
11	312.50MHz

NOTE: FSEL\_X denotes FSEL\_A, \_B, \_C, \_D, \_E.

NOTE Any two outputs operated at the same frequency will be synchronous.

**Table 3B. PLL\_SEL Control Input Function Table**

Input	Operation
<b>PLL_SEL</b>	
0	PLL Bypass
1 (default)	PLL Mode

**Table 3C. REF\_SEL Control Input Function Table**

Input	Clock Source
<b>REF_SEL</b>	
0	CLK, nCLK
1 (default)	XTAL_IN, XTAL_OUT

**Table 3D. OE\_[A:E] Control Input Function Table**

Input	Outputs
<b>OE_[A:E]</b>	<b>Q[Ax:Ex], nQ[Ax:Ex]</b>
0	High-Impedance
1 (default)	Enabled

**Table 3E. OE\_G Control Input Function Table**

Input	Outputs
<b>OE_G</b>	<b>QG</b>
0	High-Impedance
1 (default)	Enabled

**Table 3F. OE\_REF Control Input Function Table**

Input	Output
<b>OE_REF</b>	<b>QREF[0:1]</b>
0	High-Impedance
1 (default)	Enabled

## Absolute Maximum Ratings

NOTE: Stresses beyond those listed under *Absolute Maximum Ratings* may cause permanent damage to the device. These ratings are stress specifications only. Functional operation of the product at these conditions or any conditions beyond those listed in the *DC Characteristics* or *AC Characteristics* is not implied. Exposure to absolute maximum rating conditions for extended periods may affect product reliability.

Item	Rating
Supply Voltage, $V_{DD}$	4.6V
Inputs, $V_I$ XTAL_IN Other Inputs	0V to $V_{DD}$ -0.5V to $V_{DD} + 0.5V$
Outputs, $V_O$	-0.5V to $V_{DD} + 0.5V$
Package Thermal Impedance, $\theta_{JA}$	25.4°C/W (0 mps)
Storage Temperature, $T_{STG}$	-65°C to 150°C

## DC Electrical Characteristics

**Table 4A. Power Supply DC Characteristics,**

$V_{DD} = 3.3V \pm 5\%$ ,  $V_{DDO\_A:E} = V_{DDO\_F:G} = V_{DDO\_QREF} = 3.3V \pm 5\%$ ,  $T_A = -40^\circ\text{C}$  to  $85^\circ\text{C}$

Symbol	Parameter	Test Conditions	Minimum	Typical	Maximum	Units
$V_{DD}$	Core Supply Voltage		3.135	3.3	3.465	V
$V_{DDA}$	Analog Supply Voltage		$V_{DD} - 0.16$	3.3	$V_{DD}$	V
$V_{DDO\_X}$	Output Supply Voltage		3.135	3.3	3.465	V
$I_{DD}$	Power Supply Current			86	103	mA
$I_{DDA}$	Analog Supply Current			13	16	mA
$I_{DDO\_X}$	Output Supply Current	No Load, CLK selected		76	91	mA

NOTE:  $V_{DDO\_X}$  denotes  $V_{DDO\_A:E}$ ,  $V_{DDO\_F:G}$ ,  $V_{DDO\_QREF}$ .

NOTE:  $I_{DDO\_X}$  denotes  $I_{DDO\_A:E} + I_{DDO\_F:G} + I_{DDO\_QREF}$

**Table 4B. Power Supply DC Characteristics,  $V_{DD} = 3.3V \pm 5\%$ ,  $V_{DDO\_G} = V_{DDO\_QREF} = 2.5V \pm 5\%$ ,  $T_A = -40^\circ\text{C}$  to  $85^\circ\text{C}$**

Symbol	Parameter	Test Conditions	Minimum	Typical	Maximum	Units
$V_{DD}$	Core Supply Voltage		3.135	3.3	3.465	V
$V_{DDA}$	Analog Supply Voltage		$V_{DD} - 0.16$	3.3	$V_{DD}$	V
$V_{DDO\_X}$	Output Supply Voltage		2.375	2.5	2.625	V
$I_{DD}$	Power Supply Current			79	95	mA
$I_{DDA}$	Analog Supply Current			13	16	mA
$I_{DDO\_X}$	Output Supply Current	No Load, CLK selected		50	60	mA

NOTE:  $V_{DDO\_X}$  denotes  $V_{DDO\_G}$ ,  $V_{DDO\_QREF}$ .

NOTE:  $I_{DDO\_X}$  denotes  $I_{DDO\_G} + I_{DDO\_QREF}$ .

**Table 4C. LVCMOS/LVTTL DC Characteristics,  $V_{DD} = V_{DDO\_F} = 3.3V \pm 5\%$ ; or  $V_{DD} = 3.3V \pm 5\%$ ,  $V_{DDO\_G} = V_{DDO\_QREF} = 3.3V \pm 5\%$  or  $2.5V \pm 5\%$ ,  $T_A = -40^\circ\text{C}$  to  $85^\circ\text{C}$**

Symbol	Parameter		Test Conditions	Minimum	Typical	Maximum	Units
$V_{IH}$	Input High Voltage			2.2		$V_{DD} + 0.3$	V
$V_{IL}$	Input Low Voltage			-0.3		0.8	V
$I_{IH}$	Input High Current	FSEL_A[0:1], FSEL_B[0:1], FSEL_C[0:1], FSEL_D[0:1], FSEL_E[0:1]	$V_{DD} = V_{IN} = 3.465V$			150	$\mu\text{A}$
		nMR, REF_SEL, PLL_SEL, OE_REF, OE_A, OE_B, OE_C, OE_D, OE_E, OE_G	$V_{DD} = V_{IN} = 3.465V$			10	$\mu\text{A}$
$I_{IL}$	Input Low Current	FSEL_A[0:1], FSEL_B[0:1], FSEL_C[0:1], FSEL_D[0:1], FSEL_E[0:1]	$V_{DD} = 3.465V, V_{IN} = 0V$	-10			$\mu\text{A}$
		nMR, REF_SEL, PLL_SEL, OE_REF, OE_A, OE_B, OE_C, OE_D, OE_E, OE_G	$V_{DD} = 3.465V, V_{IN} = 0V$	-150			$\mu\text{A}$
$V_{OH}$	Output High Voltage		$V_{DDO\_F} = V_{DDO\_G}, V_{DDO\_QREF} = 3.465V, I_{OH} = -12\text{mA}$	2.6			V
			$V_{DDO\_G}, V_{DDO\_QREF} = 2.625V, I_{OH} = -12\text{mA}$	1.8			V
$V_{OL}$	Output Low Voltage		$V_{DDO\_F} = V_{DDO\_G}, V_{DDO\_QREF} = 3.465V$ or $V_{DDO\_G}, V_{DDO\_QREF} = 2.625V, I_{OH} = 12\text{mA}$			0.6	V

**Table 4D. Differential DC Characteristics,  $V_{DD} = 3.3V \pm 5\%$ ,  $T_A = -40^\circ\text{C}$  to  $85^\circ\text{C}$**

Symbol	Parameter		Test Conditions	Minimum	Typical	Maximum	Units
$I_{IH}$	Input High Current	CLK, nCLK	$V_{DD} = V_{IN} = 3.465V$			150	$\mu\text{A}$
$I_{IL}$	Input Low Current	CLK	$V_{DD} = 3.465V, V_{IN} = 0V$	-10			$\mu\text{A}$
		nCLK	$V_{DD} = 3.465V, V_{IN} = 0V$	-150			$\mu\text{A}$
$V_{PP}$	Peak-to-Peak Input Voltage; NOTE 1			0.15		1.3	V
$V_{CMR}$	Common Mode Input Voltage; NOTE 1, 2			0.5		$V_{DD} - 0.85$	V

NOTE 1:  $V_{IL}$  should not be less than -0.3V.

NOTE 2: Common mode voltage is defined as  $V_{IH}$ .

**Table 5. Crystal Characteristics**

Parameter	Test Conditions	Minimum	Typical	Maximum	Units
Mode of Oscillation			Fundamental		
Frequency			25		MHz
Equivalent Series Resistance (ESR)				50	$\Omega$
Shunt Capacitance				7	pF

NOTE: Characterized using an 18pF parallel resonant crystal.

**Table 6. Input Frequency Characteristics**,  $V_{DD} = 3.3V \pm 5\%$ ,  $V_{DDO\_A:E} = V_{DDO\_F} = 3.3V \pm 5\%$ ; or  $V_{DD} = 3.3V \pm 5\%$ ,  $V_{DDO\_G} = V_{DDO\_QREF} = 3.3V \pm 5\%$  or  $2.5V \pm 5\%$ ,  $T_A = -40^\circ C$  to  $85^\circ C$

Symbol	Parameter	Test Conditions	Minimum	Typical	Maximum	Units
$F_{IN}$	Input Frequency	CLK, nCLK		25		MHz
		XTAL_IN, XTAL_OUT		25		MHz

## AC Electrical Characteristics

**Table 7A. PCI Express Jitter Specifications**,  $V_{DD} = 3.3V \pm 5\%$ ,  $V_{DDO\_A:E} = 3.3V \pm 5\%$ ; and  $V_{DD} = 3.3V \pm 5\%$ ,  $V_{DDO\_G} = V_{DDO\_QREF} = 3.3V \pm 5\%$ ,  $T_A = -40^\circ C$  to  $85^\circ C$

Symbol	Parameter	Test Conditions	Minimum	Typical	Maximum	PCIe Industry Specification	Units
$t_j$ (PCIe Gen 1)	Phase Jitter Peak-to-Peak; NOTE 1, 4	$f = 100MHz$ , 25MHz Crystal Input Evaluation Band: 0Hz - Nyquist (clock frequency/2)		14.27	24.35	86	ps
$t_{REFCLK\_HF\_RMS}$ (PCIe Gen 2)	Phase Jitter RMS; NOTE 2, 4	$f = 100MHz$ , 25MHz Crystal Input High Band: 1.5MHz - Nyquist (clock frequency/2)		1.47	3.04	3.10	ps
$t_{REFCLK\_LF\_RMS}$ (PCIe Gen 2)	Phase Jitter RMS; NOTE 2, 4	$f = 100MHz$ , 25MHz Crystal Input Low Band: 10kHz - 1.5MHz		0.17	0.67	3.0	ps
$t_{REFCLK\_RMS}$ (PCIe Gen 3)	Phase Jitter RMS; NOTE 3, 4	$f = 100MHz$ , 25MHz Crystal Input Evaluation Band: 0Hz - Nyquist (clock frequency/2)		0.37	0.79	0.8	ps

NOTE: Electrical parameters are guaranteed over the specified ambient operating temperature range, which is established when the device is mounted in a test socket with maintained transverse airflow greater than 500 lfpm. The device will meet specifications after thermal equilibrium has been reached under these conditions. For additional information, refer to the *PCI Express Application Note* section in the datasheet.

NOTE 1: Peak-to-Peak jitter after applying system transfer function for the Common Clock Architecture. Maximum limit for PCI Express Gen 1 is 86ps peak-to-peak for a sample size of  $10^6$  clock periods.

NOTE 2: RMS jitter after applying the two evaluation bands to the two transfer functions defined in the Common Clock Architecture and reporting the worst case results for each evaluation band. Maximum limit for PCI Express Generation 2 is 3.1ps RMS for  $t_{REFCLK\_HF\_RMS}$  (High Band) and 3.0ps RMS for  $t_{REFCLK\_LF\_RMS}$  (Low Band).

NOTE 3: RMS jitter after applying system transfer function for the common clock architecture. This specification is based on the *PCI Express Base Specification Revision 0.7, October 2009* and is subject to change pending the final release version of the specification.

NOTE 4: This parameter is guaranteed by characterization. Not tested in production.

**Table 7B. Serial Rapid IO Switch Jitter Specification**,  $V_{DD} = 3.3V \pm 5\%$ ,  $V_{DDO\_A:E} = 3.3V \pm 5\%$ ; and  $V_{DD} = 3.3V \pm 5\%$ ,  $V_{DDO\_G} = V_{DDO\_QREF} = 3.3V \pm 5\%$ ,  $T_A = -40^\circ C$  to  $85^\circ C$

Symbol	Parameter	Test Conditions	Minimum	Typical	Maximum	IDT sRIO Specification	Units
$J_{CLK\_REF}$	Total Phase Jitter, RMS; NOTE 1, 2, 3, 4	$f = 125MHz$ , 25MHz Crystal Input, HCSL Output Clocks		0.64	1.55	3	ps

NOTE: Electrical parameters are guaranteed over the specified ambient operating temperature range, which is established when the device is mounted in a test socket with maintained transverse airflow greater than 500 lfpm. The device will meet specifications after thermal equilibrium has been reached under these conditions. For additional information, refer to the *Serial Rapid IO Application Note* section in the datasheet.

NOTE 1: Total phase jitter after applying the evaluation bands to the system transfer function for the IDT sRIO Tsi57x and Tsi620 Product Families. The transfer function is defined and illustrated in the *Serial Rapid IO Application Note* section in the datasheet and the IDT hardware manual of the Tsi57x and Tsi620. Total RMS phase jitter allowed on the reference clock of the Tsi57x and Tsi620 is specified at 3ps (max).

NOTE 2: Evaluation band with sRIO mask applied: 10Hz - 40MHz.

NOTE 3: Total phase jitter includes random and deterministic jitter.

NOTE 4: Jitter data is measured with Agilent E5052A Signal Source Analyzer.

**Table 7C. Jitter Specifications for Network Processor Core Clocks and High Speed PLLs,  $V_{DD} = 3.3V \pm 5\%$ ,  $V_{DDO\_A:E} = 3.3V \pm 5\%$ ; and  $V_{DD} = 3.3V \pm 5\%$ ,  $V_{DDO\_G} = V_{DDO\_QREF} = 3.3V \pm 5\%$ ,  $T_A = -40^\circ\text{C}$  to  $85^\circ\text{C}$**

Symbol	Parameter	Test Conditions	Output	Minimum	Typical	Maximum	Units
$J_{\text{CORE\_REFCLK}}$	Total Jitter; Peak-to-Peak NOTE 1, 2, 3	$f = 50\text{MHz}$ , 25MHz Crystal Input, Internal Processor PLL BW=1MHz	QF		32.8	70	ps
		$f = 50\text{MHz}$ , 25MHz Crystal Input, Internal Processor PLL BW=2MHz	QF		33	70.01	ps
		$f = 50\text{MHz}$ , 25MHz Crystal Input, Internal Processor PLL BW = 5MHz	QF		33.6	70.05	ps
		$f = 50\text{MHz}$ , 25MHz Crystal Input, Internal Processor PLL BW = 8MHz	QF		34.5	71.2	ps
		$f = 50\text{MHz}$ , 25MHz Crystal Input, Internal Processor PLL BW = 10MHz	QF		35.3	71.9	ps
$J_{\text{PLL\_REFCLK}}$	Total Jitter, Peak-to-Peak NOTE 1, 2, 3	$f = 125\text{MHz}$ , 25MHz Crystal Input, High Speed PLL BW = 1MHz	QG		39.5	86.7	ps
		$f = 125\text{MHz}$ , 25MHz Crystal Input, High Speed PLL BW = 2MHz	QG		39.5	86.7	ps
		$f = 125\text{MHz}$ , 25MHz Crystal Input, High Speed PLL BW = 5MHz	QG		39.9	86.9	ps
		$f = 125\text{MHz}$ , 25MHz Crystal Input, High Speed PLL BW = 8MHz	QG		41.6	88.4	ps
		$f = 125\text{MHz}$ , 25MHz Crystal Input, High Speed PLL BW = 10MHz	QG		43.3	90	ps

NOTE: Electrical parameters are guaranteed over the specified ambient operating temperature range, which is established when the device is mounted in a test socket with maintained transverse airflow greater than 500 lfpm. The device will meet specifications after thermal equilibrium has been reached under these conditions. For additional information, refer to the *Network Processor Core Clocks and High Speed PLLs Application Note* section in the datasheet.

NOTE 1: Total phase jitter after applying the evaluation bands to the system transfer function for Network Processor Clock Architecture and High Speed PLLs. The transfer function is defined and illustrated in the *Network Processor Core Clocks and High Speed PLLs Application Note* section in the datasheet.

NOTE 2: Measurement in the Frequency Domain. Evaluation Band with PLL mask applied: 10Hz - 40MHz.

NOTE 3: Jitter data is measured with Agilent E5052A Signal Source Analyzer.

**Table 7D. AC Characteristics,  $V_{DD} = 3.3V \pm 5\%$ ,  $V_{DDO\_A:E} = V_{DDO\_F} = 3.3V \pm 5\%$ ; and  $V_{DD} = 3.3V \pm 5\%$ ,  $V_{DDO\_G} = V_{DDO\_QREF} = 3.3V \pm 5\%$  or  $2.5V \pm 5\%$ ,  $T_A = -40^\circ\text{C}$  to  $85^\circ\text{C}$**

Symbol	Parameter	Test Conditions	Output	Minimum	Typical	Maximum	Units
$f_{\text{OUT}}$	Output Frequency	FSEL_[A:E] = 00	Q[A:E], nQ[A:E]		100		MHz
		FSEL_[A:E] = 01	Q[A:E], nQ[A:E]		125		MHz
		FSEL_[A:E] = 10	Q[A:E], nQ[A:E]		156.25		MHz
		FSEL_[A:E] = 11	Q[A:E], nQ[A:E]		312.5		MHz
			QF		50		MHz
			QG		125		MHz
			QREF[0:1]		25		MHz

NOTE: Electrical parameters are guaranteed over the specified ambient operating temperature range, which is established when the device is mounted in a test socket with maintained transverse airflow greater than 500 lfpm. The device will meet specifications after thermal equilibrium has been reached under these conditions.

**Table 7E. HCSL AC Characteristics**,  $V_{DD} = 3.3V \pm 5\%$ ,  $V_{DDO\_A:E} = V_{DDO\_F} = 3.3V \pm 5\%$ ; and  $V_{DD} = 3.3V \pm 5\%$ ,  $V_{DDO\_G} = V_{DDO\_QREF} = 3.3V \pm 5\%$  or  $2.5V \pm 5\%$ ,  $T_A = -40^\circ C$  to  $85^\circ C$

Symbol	Parameter	Output Configurations	Outputs	Minimum	Typical	Maximum	Units
R <sub>J</sub>	Random Jitter	QA = QD = 100MHz, QB = QG = 125MHz, QC = QE = 156.25MHz, QF = 50MHz, QREF0 = QREF1 = Disabled	QA, nQA		3	4	ps
			QB, nQB		3	4	ps
			QC, nQC		3	5	ps
			QD, nQD		3	5	ps
			QE, nQE		3	5	ps
D <sub>J</sub>	Deterministic Jitter	QA = QD = 100MHz, QB = QG = 125MHz, QC = QE = 156.25MHz, QF = 50MHz, QREF0 = QREF1 = Disabled	QA, nQA		26	55	ps
			QB, nQB		43	90	ps
			QC, nQC		48	80	ps
			QD, nQD		32	60	ps
			QE, nQE		60	85	ps
t <sub>j</sub> it(∅)	RMS Phase Jitter, (Random) Integration Range: (12kHz to 20MHz)	QA = QD = 100MHz, QB = QG = 125MHz, QC = QE = 156.25MHz, QF = 50MHz, QREF0 = QREF1 = Disabled	QA, nQA		0.77	0.96	ps
			QB, nQB		0.75	0.94	ps
			QC, nQC		0.75	1.00	ps
			QD, nQD		0.78	0.96	ps
			QE, nQE		0.76	0.95	ps
			QF		0.94	1.09	ps
			QG		0.88	1.13	ps

NOTE: Electrical parameters are guaranteed over the specified ambient operating temperature range, which is established when the device is mounted in a test socket with maintained transverse airflow greater than 500 lfpm. The device will meet specifications after thermal equilibrium has been reached under these conditions.

NOTE: Refer to Applications Section for peak-to-peak jitter calculations.

**Table 7F. HCSL AC Characteristics**,  $V_{DD} = 3.3V \pm 5\%$ ,  $V_{DDO\_A:E} = V_{DDO\_F} = 3.3V \pm 5\%$ ; and  $V_{DD} = 3.3V \pm 5\%$ ,  $V_{DDO\_G} = V_{DDO\_QREF} = 3.3V \pm 5\%$  or  $2.5V \pm 5\%$ ,  $T_A = -40^\circ C$  to  $85^\circ C$

Symbol	Parameter	Output Configurations	Outputs	Minimum	Typical	Maximum	Units
R <sub>J</sub>	Random Jitter	QA = QB = 100MHz, QC = QD = QE = 156.25MHz, QF = 50MHz, QG = 125MHz, QREF0 = QREF1 = Disabled	QA, nQA		3	4	ps
			QB, nQB		3	4	ps
			QC, nQC		3	5	ps
			QD, nQD		3	6	ps
			QE, nQE		3	5	ps
D <sub>J</sub>	Deterministic Jitter	QA = QB = 100MHz, QC = QD = QE = 156.25MHz, QF = 50MHz, QG = 125MHz, QREF0 = QREF1 = Disabled	QA, nQA		33	65	ps
			QB, nQB		27	60	ps
			QC, nQC		62	100	ps
			QD, nQD		61	110	ps
			QE, nQE		62	100	ps
t <sub>j</sub> it(∅)	RMS Phase Jitter, (Random) Integration Range: (12kHz to 20MHz)	QA = QB = 100MHz, QC = QD = QE = 156.25MHz, QF = 50MHz, QG = 125MHz, QREF0 = QREF1 = Disabled	QA, nQA		0.67	0.80	ps
			QB, nQB		0.68	0.82	ps
			QC, nQC		0.70	0.92	ps
			QD, nQD		0.75	0.89	ps
			QE, nQE		0.76	0.91	ps
			QF		0.93	1.07	ps
			QG		0.88	1.01	ps

For NOTES, see Table 7E above.

**Table 7G. HCSL AC Characteristics**,  $V_{DD} = 3.3V \pm 5\%$ ,  $V_{DDO\_A:E} = V_{DDO\_F} = 3.3V \pm 5\%$ ; and  $V_{DD} = 3.3V \pm 5\%$ ,  $V_{DDO\_G} = V_{DDO\_QREF} = 3.3V \pm 5\%$  or  $2.5V \pm 5\%$ ,  $T_A = -40^\circ\text{C}$  to  $85^\circ\text{C}$

Symbol	Parameter	Output Configurations	Outputs	Minimum	Typical	Maximum	Units
$R_J$	Random Jitter	QA = QD = 100MHz, QB = QG = 125MHz, QC = QE = 156.25MHz, QF = 50MHz, QREF0 = QREF1 = 25MHz	QA, nQA		3	5	ps
			QB, nQB		3	5	ps
			QC, nQC		3	5	ps
			QD, nQD		3	5	ps
			QE, nQE		3	5	ps
$D_J$	Deterministic Jitter	QA = QD = 100MHz, QB = QG = 125MHz, QC = QE = 156.25MHz, QF = 50MHz, QREF0 = QREF1 = 25MHz	QA, nQA		20	50	ps
			QB, nQB		43	100	ps
			QC, nQC		64	100	ps
			QD, nQD		30	80	ps
			QE, nQE		70	120	ps
$t_{jit}(\emptyset)$	RMS Phase Jitter, (Random) Integration Range: (10kHz to 1.5MHz)	QA = QD = 100MHz, QB = QG = 125MHz, QC = QE = 156.25MHz, QF = 50MHz, QREF0 = QREF1 = 25MHz	QA, nQA; QD, nQD		0.66	0.76	ps
	RMS Phase Jitter, (Random) Integration Range: (1.5MHz to 50MHz)		QA, nQA; QD, nQD		0.56	0.68	ps
	RMS Phase Jitter, (Random) Integration Range: (20MHz to 78.125MHz)		QC, nQC; QE, nQE		0.34	0.48	ps
	RMS Phase Jitter, (Random) Integration Range: (12kHz to 50MHz)		QC, nQC; QE, nQE		0.85	0.95	ps

NOTE: Electrical parameters are guaranteed over the specified ambient operating temperature range, which is established when the device is mounted in a test socket with maintained transverse airflow greater than 500 lfm. The device will meet specifications after thermal equilibrium has been reached under these conditions.

NOTE: Refer to Applications Section for peak-to-peak jitter calculations.

**Table 7H. AC Characteristics**,  $V_{DD} = 3.3V \pm 5\%$ ,  $V_{DDO\_A:E} = V_{DDO\_F} = 3.3V \pm 5\%$ ; and  $V_{DD} = 3.3V \pm 5\%$ ,  $V_{DDO\_G} = V_{DDO\_QREF} = 3.3V \pm 5\%$  or  $2.5V \pm 5\%$ ,  $T_A = -40^\circ\text{C}$  to  $85^\circ\text{C}$

Symbol	Parameter	Test Conditions	Minimum	Typical	Maximum	Units	
$V_{RB}$	Ring-Back Voltage Margin; NOTE 1, 2	Q[A:E], nQ[A:E]	-100		100	mV	
$t_{STABLE}$	Time before $V_{RB}$ is allowed; NOTE 1, 2	Q[A:E], nQ[A:E]	500			ps	
$V_{MAX}$	Absolute Max Output Voltage; NOTE 3, 4	Q[A:E], nQ[A:E]			1150	mV	
$V_{MIN}$	Absolute Min Output Voltage; NOTE 3, 5	Q[A:E], nQ[A:E]	-300			mV	
$V_{CROSS}$	Absolute Crossing Voltage; NOTE 3, 6, 7	Q[A:E], nQ[A:E]	250		550	mV	
$\Delta V_{CROSS}$	Total Variation of $V_{CROSS}$ over All Edges; NOTE 3, 6, 8	Q[A:E], nQ[A:E]			140	mV	
$t_{SLEW+}$	Rising Edge Rate; NOTE 1, 9	Q[A:E], nQ[A:E]	0.6		5.5	V/ns	
$t_{SLEW-}$	Falling Edge Rate; NOTE 1, 9	Q[A:E], nQ[A:E]	0.6		5.5	V/ns	
odc	Output Duty Cycle	Q[A:E], nQ[A:E]	48		52	%	
$t_{jit}(\emptyset)$	RMS Phase Jitter, (Random)	QREF[0:1]	25MHz, Integration Range: (10kHz to 5MHz)		0.6	0.96	ps
$t_R / t_F$	Output Rise/Fall Time	QF	20% to 80%	400	1400	ps	
		QG	20% to 80%	400	1400	ps	
		QREF[0:1]	20% to 80%	300	1400	ps	
odc	Output Duty Cycle	QF	measured at $V_{DDO\_F}/2$	48	50	52	%
		QG	measured at $V_{DDO\_G}/2$	45	50	55	%
		QREF[0:1]	measured at $V_{DDO\_QREF}/2$	45	50	55	%

NOTE: Electrical parameters are guaranteed over the specified ambient operating temperature range, which is established when the device is mounted in a test socket with maintained transverse airflow greater than 500 lfpm. The device will meet specifications after thermal equilibrium has been reached under these conditions.

NOTE: All parameters measured at  $f_{OUT}$  unless noted otherwise.

NOTE 1: Measurement taken from differential waveform.

NOTE 2:  $t_{STABLE}$  is the time the differential clock must maintain a minimum  $\pm 150\text{mV}$  differential voltage after rising/falling edges before it is allowed to drop back into the  $V_{rb} \pm 100\text{mV}$  range. See Parameter Measurement Information Section.

NOTE 3: Measurement taken from single-ended waveform.

NOTE 4: Defined as the maximum instantaneous voltage including overshoot. See Parameter Measurement Information Section.

NOTE 5: Defined as the minimum instantaneous voltage including undershoot. See Parameter Measurement Information Section.

NOTE 6: Measured at the crossing point where the instantaneous voltage value of the rising edge of Q[Ax:Ex] equals the falling edge of nQ[Ax:Ex].

NOTE 7: Refers to the total variation from the lowest crossing point to the highest, regardless of which edge is crossing. Refers to all crossing points for this measurement.

NOTE 8: Defined as the total variation of all crossing voltages of rising Q[Ax:Ex] and falling nQ[Ax:Ex]. This is the maximum allowed variance in  $V_{cross}$  for any particular system.

NOTES continued on next page.

NOTE 9: Measured from  $-150\text{mV}$  to  $+150\text{mV}$  on the differential waveform (derived from Q[Ax:Ex] minus nQ[Ax:Ex]). The signal must be monotonic through the measurement region for rise and fall time. The  $300\text{mV}$  measurement window is centered on the differential zero crossing.

### Typical Phase Noise at 156.25MHz

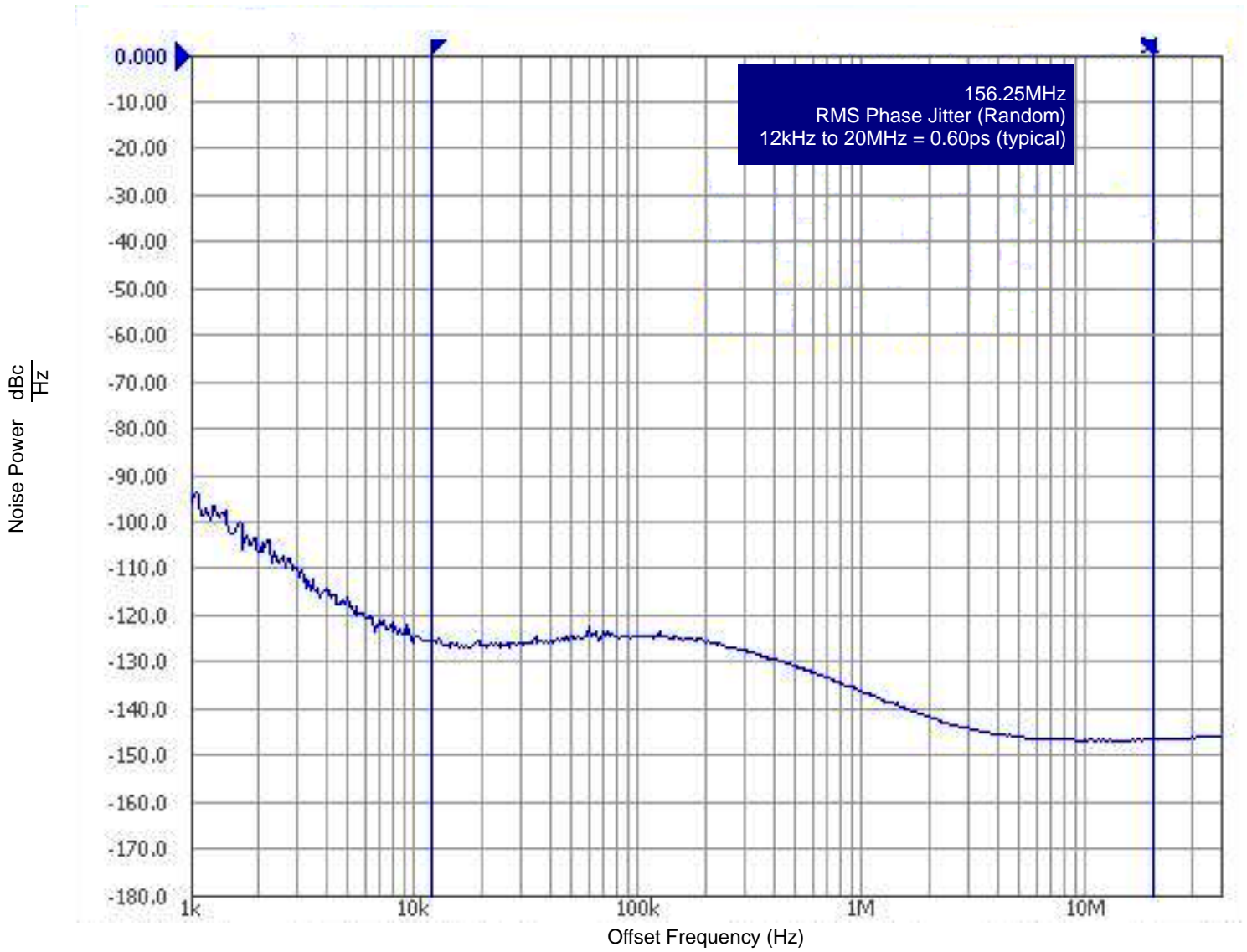

## Parameter Measurement Information

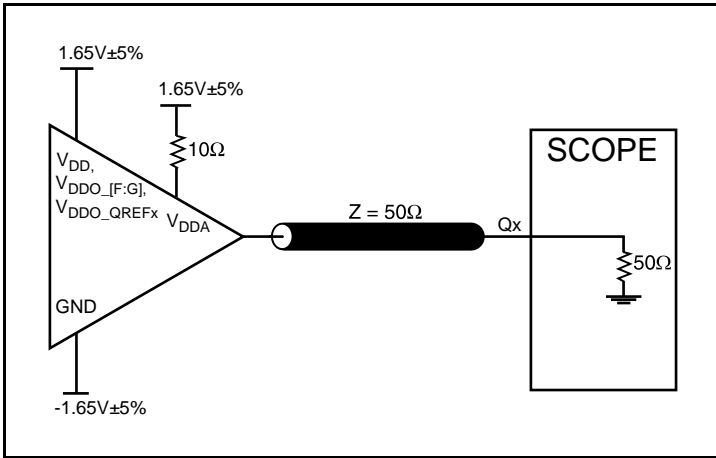

3.3V Core/3.3V LVCMOS Output Load AC Test Circuit

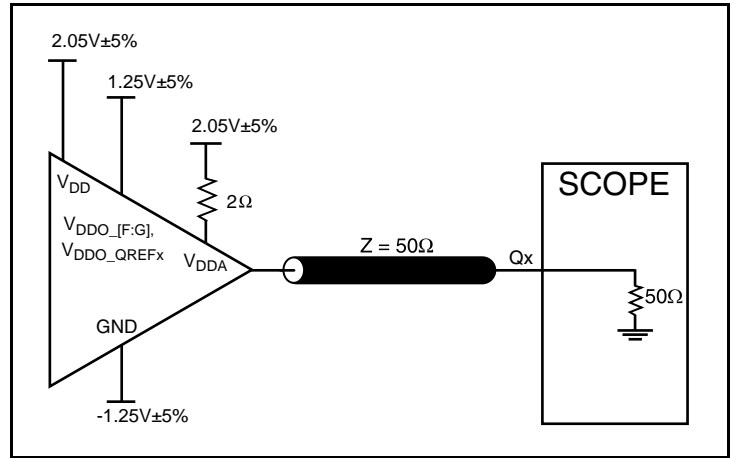

3.3V Core/2.5V LVCMOS Output Load AC Test Circuit

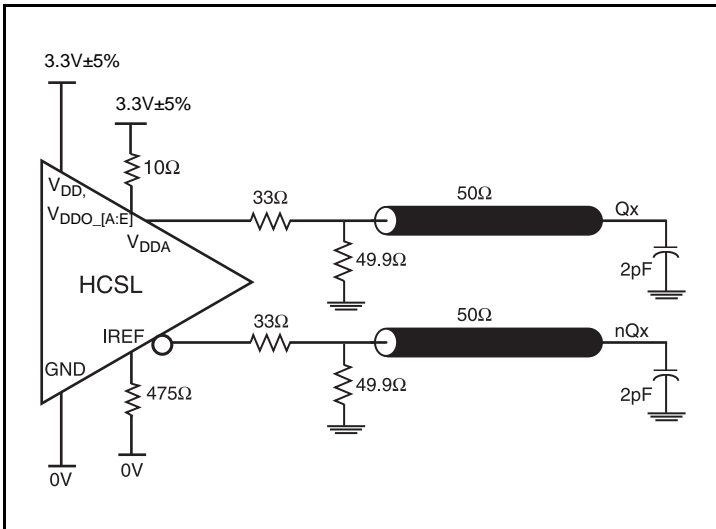

3.3V Core/3.3V HCSL Output Load AC Test Circuit

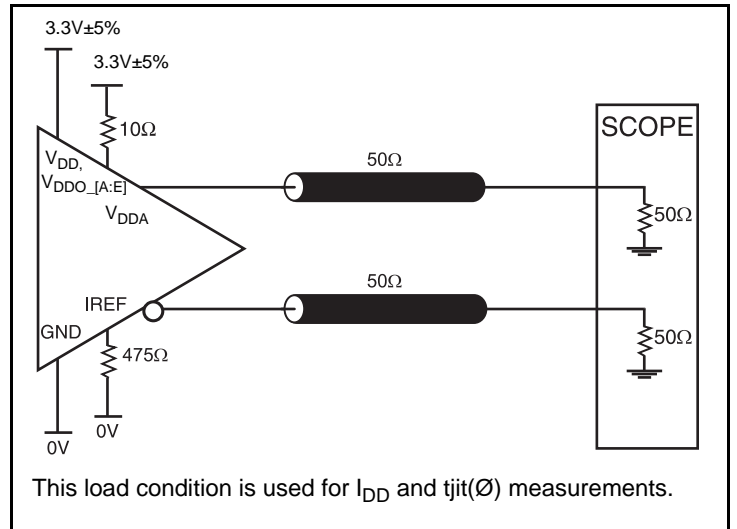

3.3V Core/3.3V HCSL Output Load AC Test Circuit

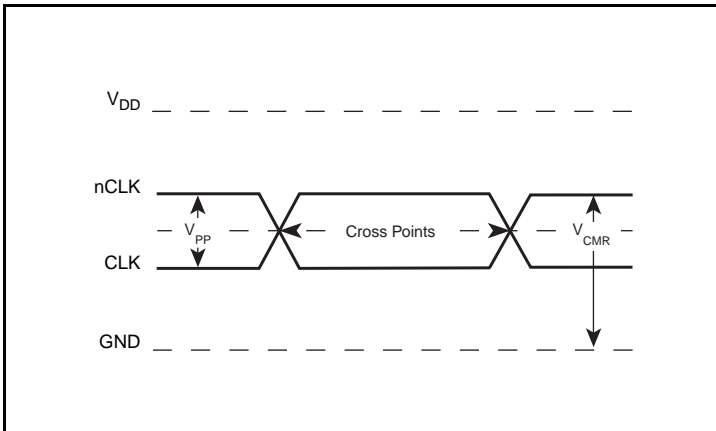

Differential Input Level

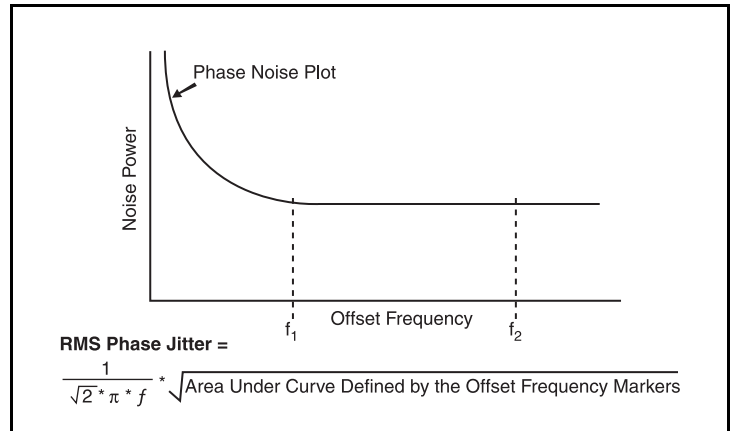

RMS Phase Jitter

Parameter Measurement Information, continued

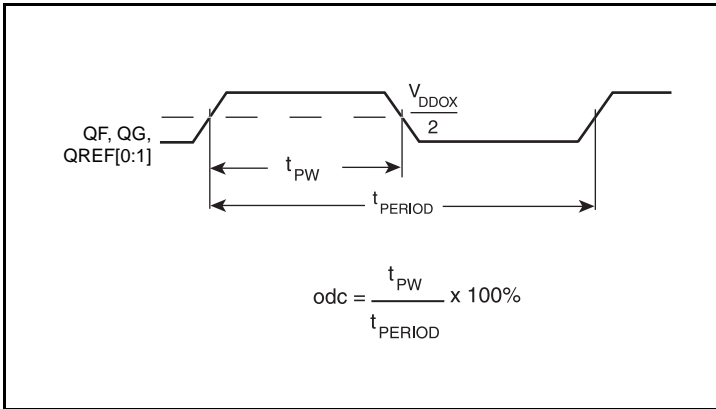

LVC MOS Output Duty Cycle/Pulse Width

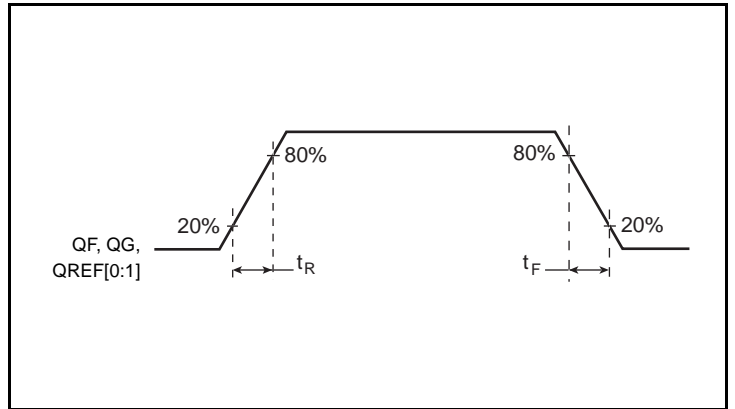

LVC MOS Output Rise/Fall Time

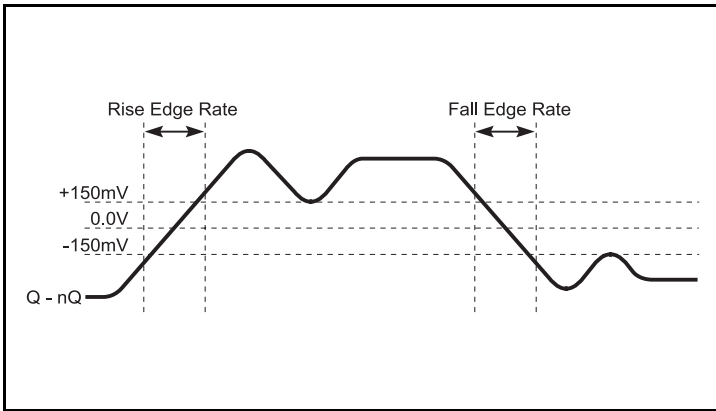

Differential Measurement Points for Rise/Fall Time Edge Rate

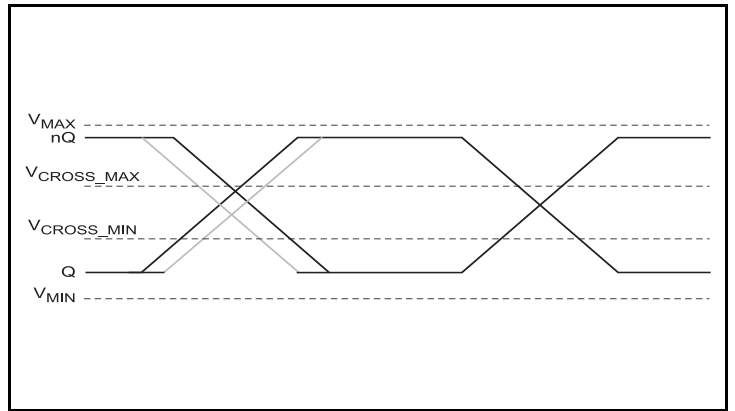

Single-ended Measurement Points for Absolute Cross Point/Swing

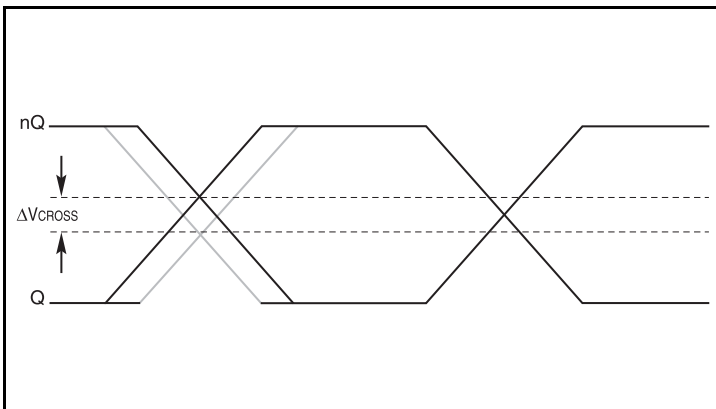

Single-ended Measurement Points for Delta Cross Point

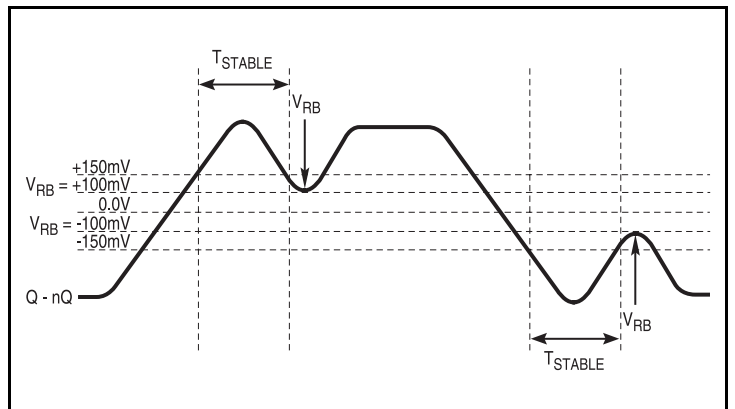

Differential Measurement Points for Ringback

## Parameter Measurement Information, continued

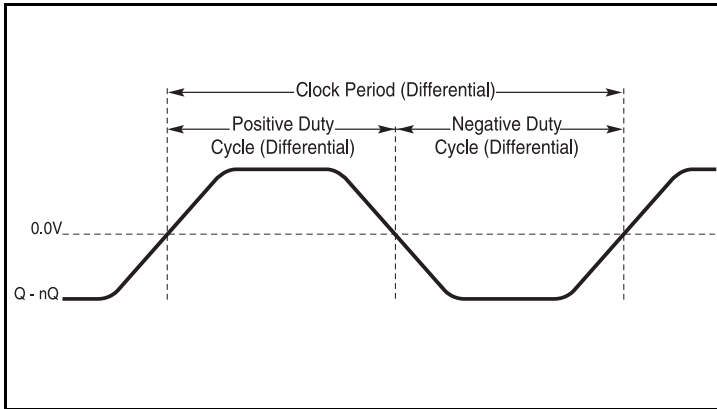

Differential Measurement Points for Duty Cycle/Period

## Peak-to-Peak Jitter Calculations

A standard deviation of a statistical population or data set is the square root of its variance. A standard deviation is used to calculate the probability of an anomaly or to predict a failure. Many times, the term “root mean square” (RMS) is used synonymously for standard deviation. This is accurate when referring to the square root of the mean squared deviation of a signal from a given baseline and when the data set contains a Gaussian distribution with no deterministic components. A low standard deviation indicates that the data set is close to the mean with little variation. A large standard deviation indicates that the data set is spread out and has a large variation from the mean.

A standard deviation is required when calculating peak-to-peak jitter. Since true peak-to-peak jitter is random and unbounded, it is important to always associate a bit error ratio (BER) when specifying a peak-to-peak jitter limit. Without it, the specification does not have a boundary and will continue get larger with sample size. Given that a BER is application specific, many frequency timing devices specify jitter as an RMS. This allows the peak-to-peak jitter to be calculated for the specific application and BER requirement. Because a standard deviation is the variation from the *mean* of the data set, it is important to always calculate the peak-to-peak jitter using the typical RMS value.

The *Table 8* shows the BER with its appropriate RMS Multiplier. There are two columns for the RMS multiplier, one should be used if your signal is data and the other should be used if the signal is a repetitive clock signal. The difference between the two is the data transition density (DTD). The DTD is the number of rising or falling transitions divided by the total number of bits. For a clock signal, they are equal, hence the DTD is 1. For Data, on average, most common encoding standards have a 0.5 DTD.

**Table 8. BER Table**

BER	RMS Multiplier Data, “DTD = 0.5”	RMS Multiplier Clock, “DTD = 1”
10 <sup>-3</sup>	6.180	6.582
10 <sup>-4</sup>	7.438	7.782
10 <sup>-5</sup>	8.530	8.834
10 <sup>-6</sup>	9.507	9.784
10 <sup>-7</sup>	10.399	10.654
10 <sup>-8</sup>	11.224	11.462
10 <sup>-9</sup>	11.996	12.218
10 <sup>-10</sup>	12.723	12.934
10 <sup>-11</sup>	13.412	13.614
10 <sup>-12</sup>	14.069	14.260
10 <sup>-13</sup>	14.698	14.882
10 <sup>-14</sup>	15.301	15.478
10 <sup>-15</sup>	15.883	16.028

Once the BER is chosen, there are two circumstances to consider. Is the data set purely Gaussian or does it contains any deterministic component? If it is Gaussian, then the peak to peak jitter can be calculated by simply multiplying the RMS multiplier with the typical RMS specification. For example, if a 10<sup>-12</sup> BER is required for a clock signal, multiply 14.260 times the typical jitter specification.

$$\text{Jitter (peak-to-peak)} = \text{RMS Multiplier} * \text{RMS (typical)}$$

If the datasheet contains deterministic components, then the random jitter ( $R_J$ ) and deterministic jitter ( $D_J$ ) must be separated and analyzed separately.  $R_J$ , also known as Gaussian jitter, is not bounded and the peak-to-peak will continue to get larger as the sample size increases. Alternatively, peak-to-peak value of  $D_J$  is bounded and can easily be observed and predicted. Therefore, the peak to peak jitter for the random component must be added to the deterministic component. This is called total jitter ( $T_J$ ).

$$\text{Total Jitter (peak-to-peak)} = [\text{RMS Multiplier} * \text{Random Jitter (R}_J)] + \text{Deterministic Jitter (D}_J)$$

The *total jitter equation* is not specific to one type of jitter classification. It can be used to calculate BER on various types of RMS jitter. It is important that the user understands their jitter requirement to ensure they are calculating the correct BER for their jitter requirement.

NOTE: Use  $R_J$  and  $D_J$  values for AC Characteristics Tables 7B through 7G to calculate  $T_J$ .

## Applications Information

### Wiring the Differential Input to Accept Single-Ended Levels

Figure 1 shows how a differential input can be wired to accept single ended levels. The reference voltage  $V_1 = V_{DD}/2$  is generated by the bias resistors R1 and R2. The bypass capacitor (C1) is used to help filter noise on the DC bias. This bias circuit should be located as close to the input pin as possible. The ratio of R1 and R2 might need to be adjusted to position the  $V_1$  in the center of the input voltage swing. For example, if the input clock swing is 2.5V and  $V_{DD} = 3.3V$ , R1 and R2 value should be adjusted to set  $V_1$  at 1.25V. The values below are for when both the single ended swing and  $V_{DD}$  are at the same voltage. This configuration requires that the sum of the output impedance of the driver ( $R_o$ ) and the series resistance ( $R_s$ ) equals the transmission line impedance. In addition, matched termination at the input will attenuate the signal in half. This can be done in one of two ways. First, R3 and R4 in parallel should equal the transmission

line impedance. For most 50Ω applications, R3 and R4 can be 100Ω. The values of the resistors can be increased to reduce the loading for slower and weaker LVCMOS driver. When using single-ended signaling, the noise rejection benefits of differential signaling are reduced. Even though the differential input can handle full rail LVCMOS signaling, it is recommended that the amplitude be reduced. The datasheet specifies a lower differential amplitude, however this only applies to differential signals. For single-ended applications, the swing can be larger, however  $V_{IL}$  cannot be less than -0.3V and  $V_{IH}$  cannot be more than  $V_{DD} + 0.3V$ . Though some of the recommended components might not be used, the pads should be placed in the layout. They can be utilized for debugging purposes. The datasheet specifications are characterized and guaranteed by using a differential signal.

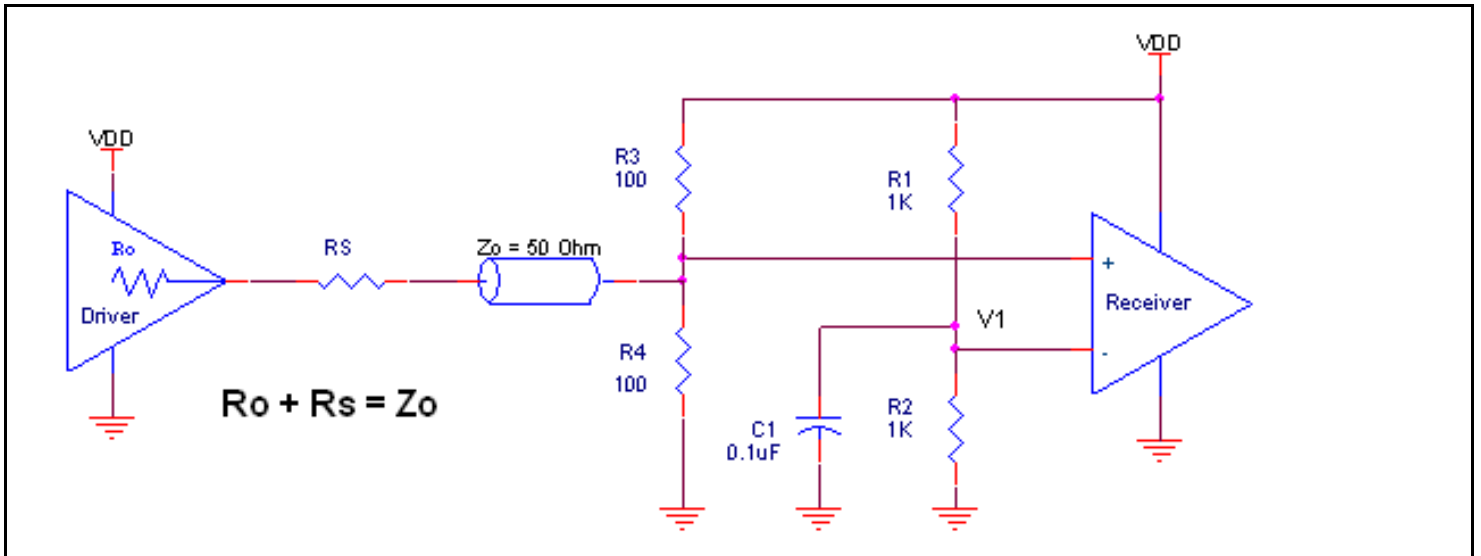

Figure 1. Recommended Schematic for Wiring a Differential Input to Accept Single-ended Levels

## Differential Clock Input Interface

The CLK /nCLK accepts LVDS, LVPECL, LVHSTL, HCSL and other differential signals. Both signals must meet the  $V_{PP}$  and  $V_{CMR}$  input requirements. Figures 2A to 2E show interface examples for the CLK/nCLK input driven by the most common driver types. The input interfaces suggested here are examples only. Please consult with the

vendor of the driver component to confirm the driver termination requirements. For example, in Figure 2A, the input termination applies for IDT open emitter LVHSTL drivers. If you are using an LVHSTL driver from another vendor, use their termination recommendation.

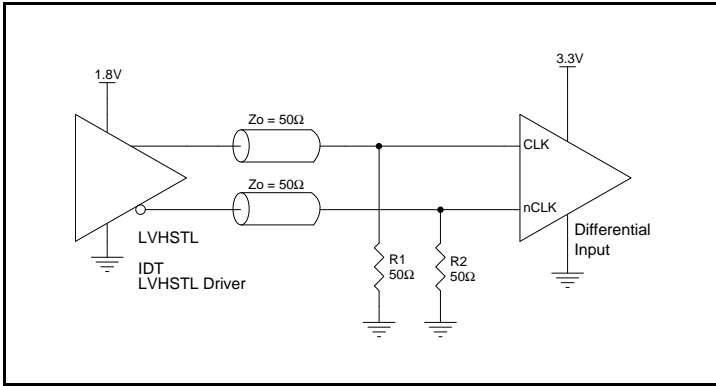

Figure 2A. CLK/nCLK Input Driven by an IDT Open Emitter LVHSTL Driver

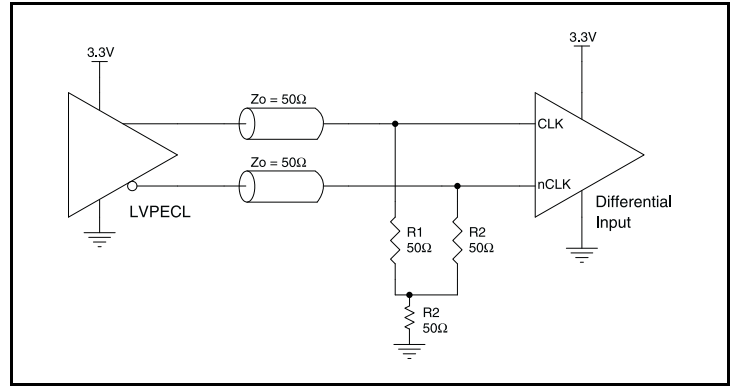

Figure 2B. CLK/nCLK Input Driven by a 3.3V LVPECL Driver

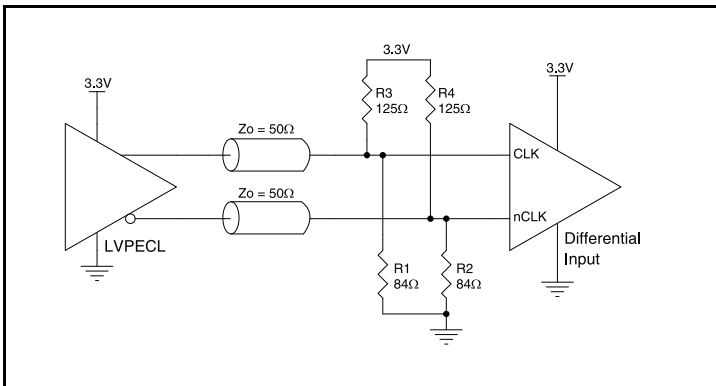

Figure 2C. CLK/nCLK Input Driven by a 3.3V LVPECL Driver

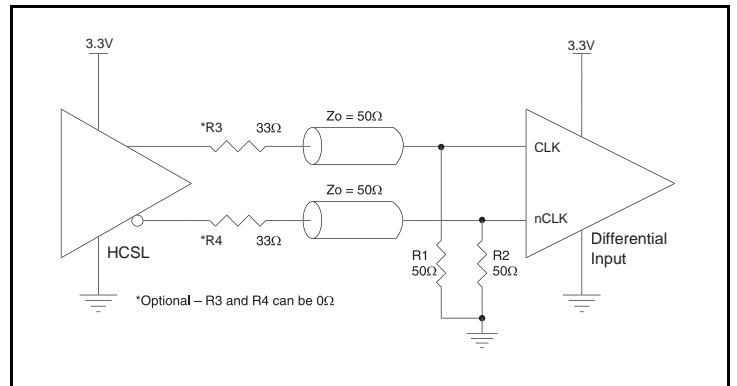

Figure 2D. CLK/nCLK Input Driven by a 3.3V HCSL Driver

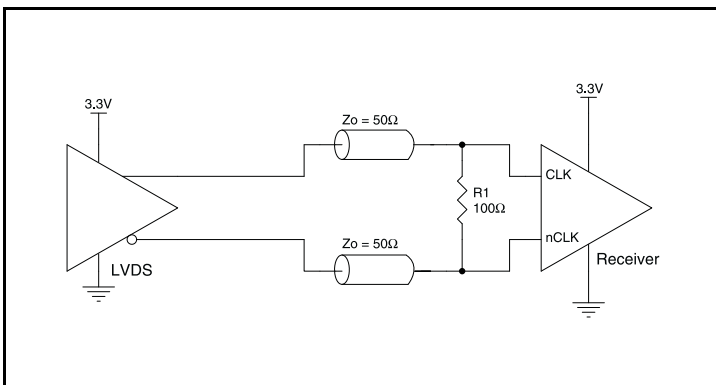

Figure 2E. CLK/nCLK Input Driven by a 3.3V LVDS Driver

## Overdriving the XTAL Interface

The XTAL\_IN input can be overdriven by an LVCMOS driver or by one side of a differential driver through an AC coupling capacitor. The XTAL\_OUT pin can be left floating. The amplitude of the input signal should be between 500mV and 1.8V and the slew rate should not be less than 0.2V/nS. For 3.3V LVCMOS inputs, the amplitude must be reduced from full swing to at least half the swing in order to prevent signal interference with the power rail and to reduce internal noise. *Figure 3A* shows an example of the interface diagram for a high speed 3.3V LVCMOS driver. This configuration requires that the sum of the output impedance of the driver ( $R_o$ ) and the series resistance ( $R_s$ ) equals the transmission line impedance. In addition, matched termination at the crystal input will attenuate the signal in half. This

can be done in one of two ways. First,  $R_1$  and  $R_2$  in parallel should equal the transmission line impedance. For most 50Ω applications,  $R_1$  and  $R_2$  can be 100Ω. This can also be accomplished by removing  $R_1$  and changing  $R_2$  to 50Ω. The values of the resistors can be increased to reduce the loading for a slower and weaker LVCMOS driver. *Figure 3B* shows an example of the interface diagram for an LVPECL driver. This is a standard LVPECL termination with one side of the driver feeding the XTAL\_IN input. It is recommended that all components in the schematics be placed in the layout. Though some components might not be used, they can be utilized for debugging purposes. The datasheet specifications are characterized and guaranteed by using a quartz crystal as the input.

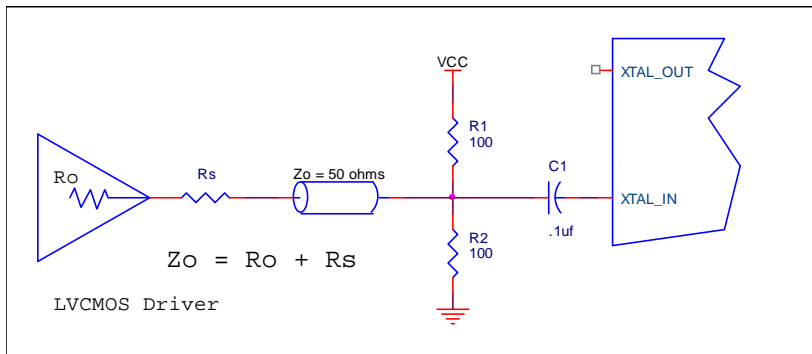

Figure 3A. General Diagram for LVCMOS Driver to XTAL Input Interface

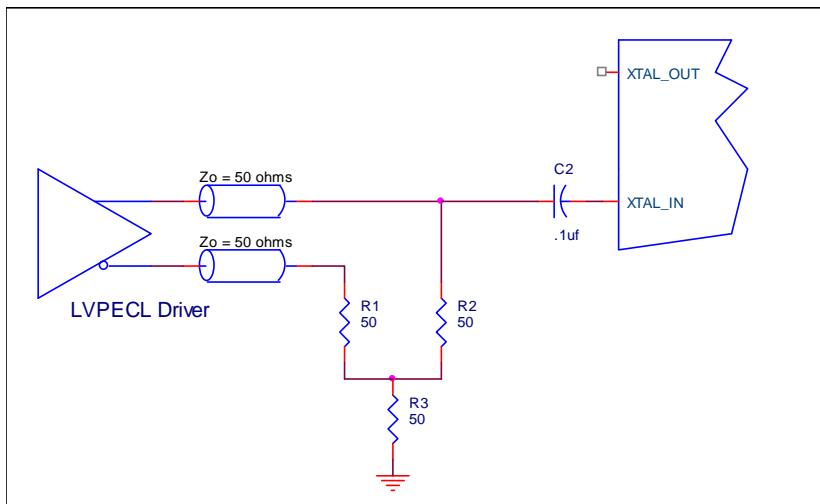

Figure 3B. General Diagram for LVPECL Driver to XTAL Input Interface

## Recommended Termination

Figure 4A is the recommended source termination for applications where the driver and receiver will be on a separate PCBs. This termination is the standard for PCI Express™ and HCSL output

types. All traces should be 50Ω impedance single-ended or 100Ω differential.

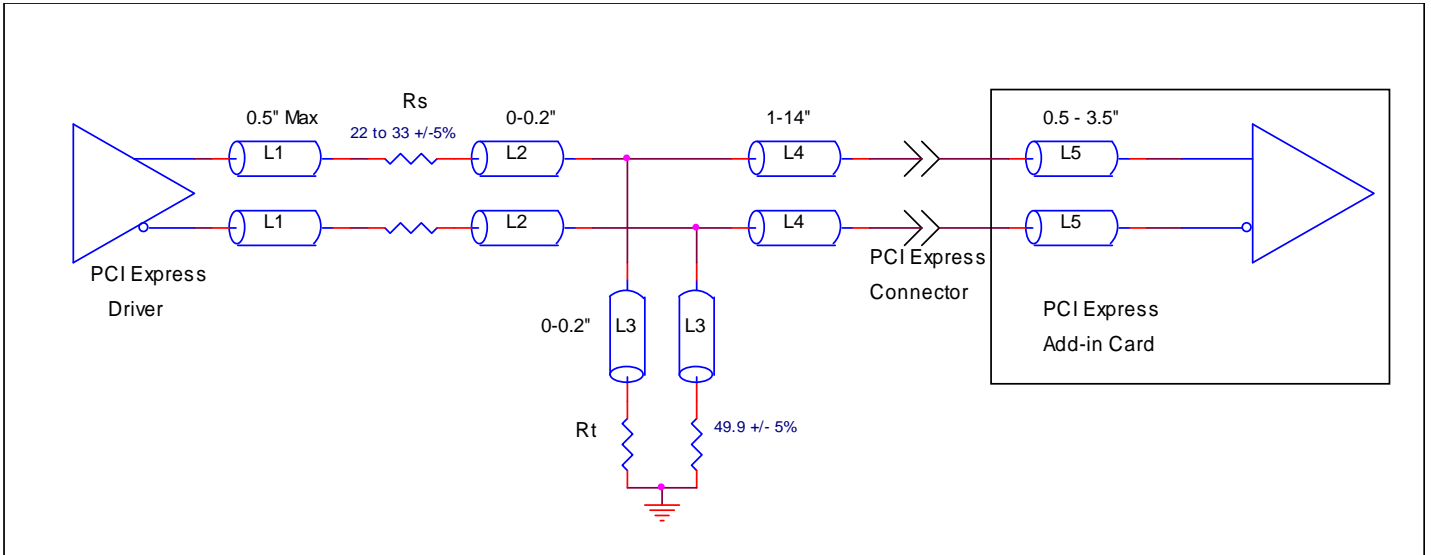

Figure 4A. Recommended Source Termination (where the driver and receiver will be on separate PCBs)

Figure 4B is the recommended termination for applications where a point-to-point connection can be used. A point-to-point connection contains both the driver and the receiver on the same PCB. With a matched termination at the receiver, transmission-line reflections will

be minimized. In addition, a series resistor (Rs) at the driver offers flexibility and can help dampen unwanted reflections. The optional resistor can range from 0Ω to 33Ω. All traces should be 50Ω impedance single-ended or 100Ω differential.

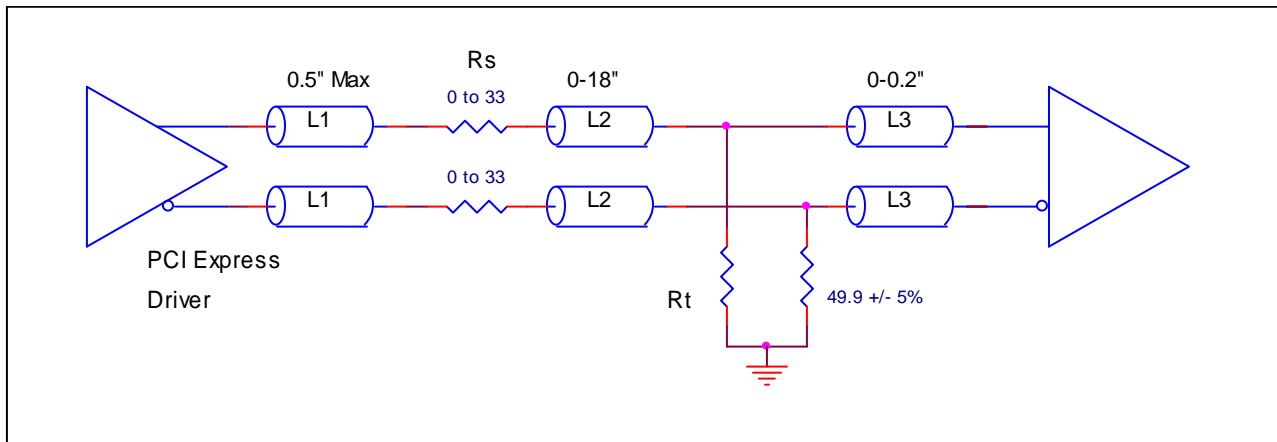

Figure 4B. Recommended Termination (where a point-to-point connection can be used)

## VFQFN EPAD Thermal Release Path

In order to maximize both the removal of heat from the package and the electrical performance, a land pattern must be incorporated on the Printed Circuit Board (PCB) within the footprint of the package corresponding to the exposed metal pad or exposed heat slug on the package, as shown in *Figure 5*. The solderable area on the PCB, as defined by the solder mask, should be at least the same size/shape as the exposed pad/slug area on the package to maximize the thermal/electrical performance. Sufficient clearance should be designed on the PCB between the outer edges of the land pattern and the inner edges of pad pattern for the leads to avoid any shorts.

While the land pattern on the PCB provides a means of heat transfer and electrical grounding from the package to the board through a solder joint, thermal vias are necessary to effectively conduct from the surface of the PCB to the ground plane(s). The land pattern must be connected to ground through these vias. The vias act as “heat pipes”. The number of vias (i.e. “heat pipes”) are application specific

and dependent upon the package power dissipation as well as electrical conductivity requirements. Thus, thermal and electrical analysis and/or testing are recommended to determine the minimum number needed. Maximum thermal and electrical performance is achieved when an array of vias is incorporated in the land pattern. It is recommended to use as many vias connected to ground as possible. It is also recommended that the via diameter should be 12 to 13mils (0.30 to 0.33mm) with 1oz copper via barrel plating. This is desirable to avoid any solder wicking inside the via during the soldering process which may result in voids in solder between the exposed pad/slug and the thermal land. Precautions should be taken to eliminate any solder voids between the exposed heat slug and the land pattern. Note: These recommendations are to be used as a guideline only. For further information, please refer to the Application Note on the Surface Mount Assembly of Amkor’s Thermally/Electrically Enhance Leadframe Base Package, Amkor Technology.

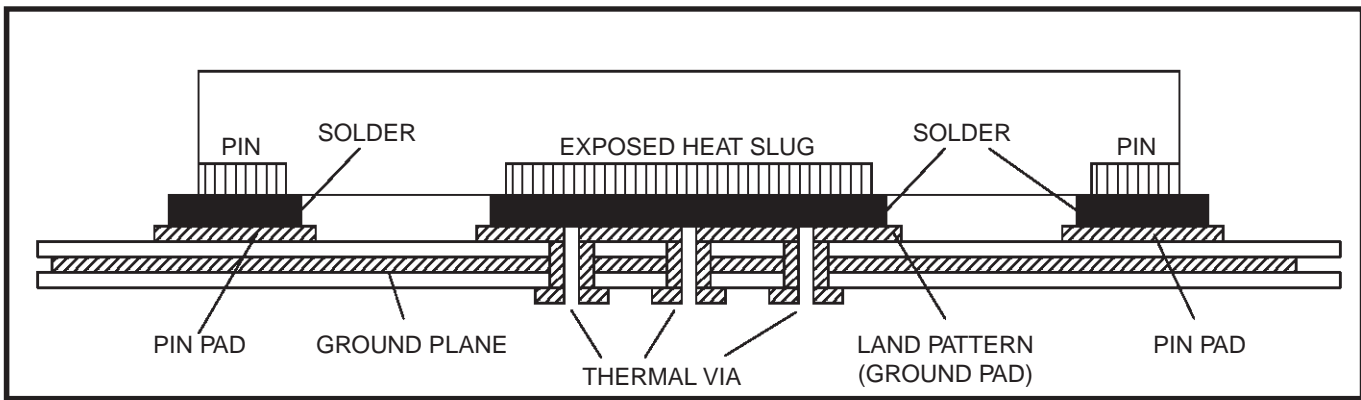

Figure 5. P.C. Assembly for Exposed Pad Thermal Release Path – Side View (drawing not to scale)

## Recommendations for Unused Input and Output Pins

### Inputs:

#### LVC MOS Control Pins

All control pins have internal pullups or pulldowns; additional resistance is not required but can be added for additional protection. A 1kΩ resistor can be used.

#### Crystal Inputs

For applications not requiring the use of the crystal oscillator input, both XTAL\_IN and XTAL\_OUT can be left floating. Though not required, but for additional protection, a 1kΩ resistor can be tied from XTAL\_IN to ground.

#### CLK/nCLK Inputs

For applications not requiring the use of the differential input, both CLK and nCLK can be left floating. Though not required, but for additional protection, a 1kΩ resistor can be tied from CLK to ground.

### Outputs:

#### LVC MOS Outputs

All unused LVC MOS outputs can be left floating. There should be no trace attached.

#### Differential Outputs

All unused differential outputs can be left floating. We recommend that there is no trace attached. Both sides of the differential output pair should either be left floating or terminated.

## Schematic Example

Figure 6 (next page) shows an example of 8413S12B application schematic. The schematic example focuses on functional connections and is not configuration specific. Refer to the pin description and functional tables in the datasheet to ensure that the logic control inputs are properly set. In this example, the device is operated at  $V_{DD} = V_{DDO\_A} = V_{DDO\_B} = V_{DDO\_C} = V_{DDO\_D} = V_{DDO\_E} = V_{DDO\_F} = 3.3V$  and  $V_{DDO\_QREF} = 3.3V$ .

The 18pF parallel resonant 25MHz crystal is used. The load capacitance  $C1 = 22pF$  and  $C2 = 10pF$  are recommended for frequency accuracy. Depending on the parasitic of the printed circuit board layout, these values might require a slight adjustment to optimize the frequency accuracy. Crystals with other load capacitance specifications can be used. This will require adjusting  $C1$  and  $C2$ . For this device, the crystal load capacitors are required for proper operation.

Crystal layout is very important to minimize capacitive coupling between the crystal pads and leads and other metal in the circuit board. Capacitive coupling to other conductors has two adverse effects; it reduces the oscillator frequency leaving less tuning margin and noise coupling from power planes and logic transitions on signal traces can pull the phase of the crystal resonance, inducing jitter. Routing I<sup>2</sup>C under the crystal is a very common layout error, based on the assumption that it is a low frequency signal and will not affect the crystal oscillation. In fact, I<sup>2</sup>C transition times are short enough to capacitively couple into the crystal if they are routed close enough to the crystal traces.

In layout, all capacitive coupling to the crystal from any signal trace is to be minimized, that is to the XTAL\_IN and XTAL\_OUT pins, traces to the crystal pads, the crystal pads and the tuning capacitors. Using a crystal on the top layer as an example, void all signal and power

layers under the crystal connections between the top layer and the ground plane used by the 8413S12B. Then calculate the parasitic capacity to the ground and determine if it is large enough to preclude tuning the oscillator. If the coupling is excessive, particularly if the first layer under the crystal is a ground plane, a layout option is to void the ground plane and all deeper layers until the next ground plane is reached. The ground connection of the tuning capacitors should first be made between the capacitors on the top layer, then a single ground via is dropped to connect the tuning cap ground to the ground plane as close to the 8413S12B as possible as shown in the schematic.

As with any high speed analog circuitry, the power supply pins are vulnerable to random noise. To achieve optimum jitter performance, power supply isolation is required. The 8413S12B provides separate power supplies to isolate any high switching noise from coupling into the internal PLL.

In order to achieve the best possible filtering, it is recommended that the placement of the filter components be on the device side of the PCB as close to the power pins as possible. The 0.1uF capacitor in each power pin filter and the 10 ohm VDDA filter resistor must be placed on the device side of the board. If space is limited, the other bulk filtering components can be on the side opposite the device side of the PCB.

Power supply filter recommendations are a general guideline to be used for reducing external noise from coupling into the devices. The filter performance is designed for a wide range of noise frequencies. This low-pass filter starts to attenuate noise at approximately 10 kHz. If a specific frequency noise component is known, such as switching power supplies frequencies, it is recommended that component values be adjusted and if required, additional filtering be added.



## PCI Express Application Note

PCI Express jitter analysis methodology models the system response to reference clock jitter. The block diagram below shows the most frequently used *Common Clock Architecture* in which a copy of the reference clock is provided to both ends of the PCI Express Link.

In the jitter analysis, the transmit (Tx) and receive (Rx) serdes PLLs are modeled as well as the phase interpolator in the receiver. These transfer functions are called H1, H2, and H3 respectively. The overall system transfer function at the receiver is:

$$H_t(s) = H_3(s) \times [H_1(s) - H_2(s)]$$

The jitter spectrum seen by the receiver is the result of applying this system transfer function to the clock spectrum X(s) and is:

$$Y(s) = X(s) \times H_3(s) \times [H_1(s) - H_2(s)]$$

In order to generate time domain jitter numbers, an inverse Fourier Transform is performed on  $X(s) \times H_3(s) \times [H_1(s) - H_2(s)]$ .

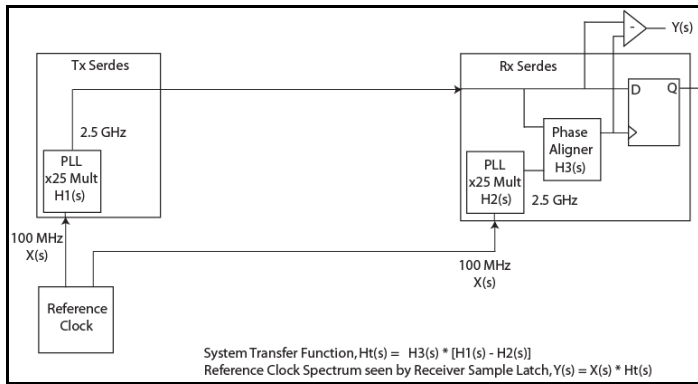

### PCI Express Common Clock Architecture

For **PCI Express Gen 1**, one transfer function is defined and the evaluation is performed over the entire spectrum: DC to Nyquist (e.g. for a 100MHz reference clock: 0Hz – 50MHz) and the jitter result is reported in peak-peak.

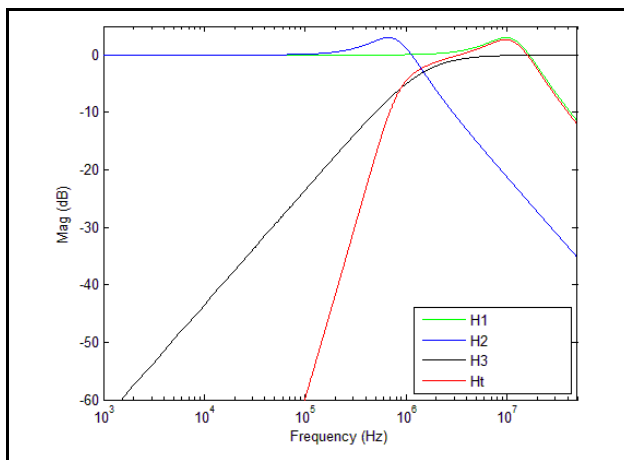

### PCI Express Gen 1 Magnitude of Transfer Function

For **PCI Express Gen 2**, two transfer functions are defined with 2 evaluation ranges and the final jitter number is reported in rms. The two evaluation ranges for PCI Express Gen 2 are 10kHz – 1.5MHz (Low Band) and 1.5MHz – Nyquist (High Band). The plots show the individual transfer functions as well as the overall transfer function Ht.

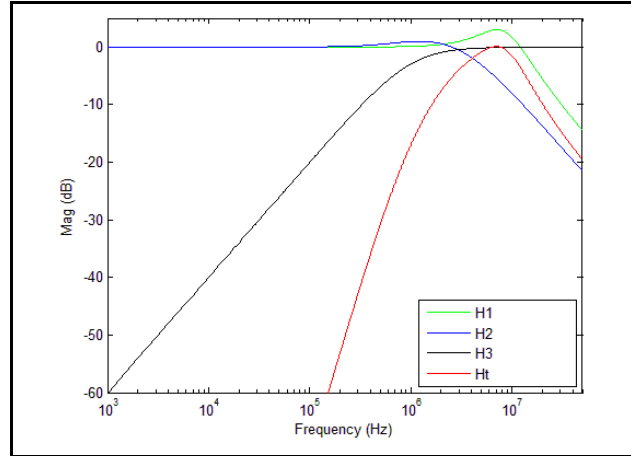

### PCI Express Gen 2A Magnitude of Transfer Function

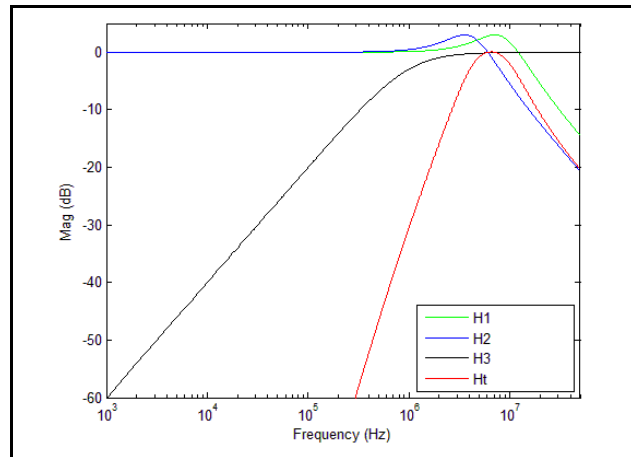

### PCI Express Gen 2B Magnitude of Transfer Function

For **PCI Express Gen 3**, one transfer function is defined and the evaluation is performed over the entire spectrum. The transfer function parameters are different from Gen 1 and the jitter result is reported in RMS.

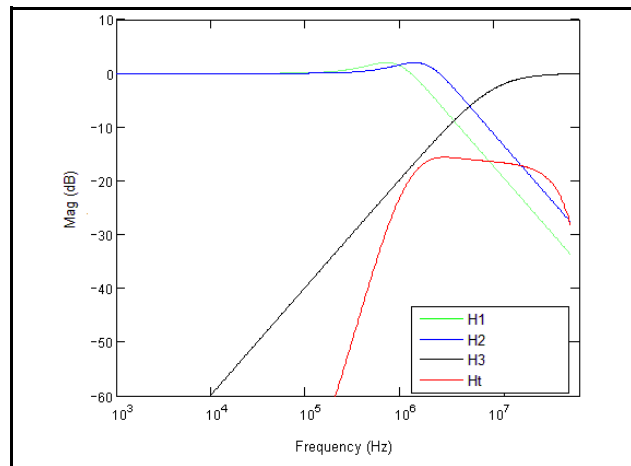

### PCI Express Gen 3 Magnitude of Transfer Function

For a more thorough overview of PCI Express jitter analysis methodology, please refer to IDT Application Note *PCI Express Reference Clock Requirements*.

## Serial Rapid IO Application Note

The Serial Rapid IO jitter analysis methodology models the system response to reference clock jitter. The total RMS phase jitter allowed on the reference clock of the Tsi57x and Tsi620 is specified at 3ps (max). In this jitter analysis, the TSI57x and Tsi620 SERDES PLL is modeled by the transfer response function  $H(s)$  shown in *Figure 7*. To model the response of the switch on the reference clock jitter, a phase noise measurement is executed and a frequency domain analysis is performed. In the phase noise plot, the mask of the

transfer function  $H(s)$  is applied to the phase noise response of the reference clock. The area under the resultant phase noise curve is referred to as Phase Jitter. In the frequency domain, the random and deterministic jitter can be calculated quickly and accurately. RMS Phase Jitter is also referred to as random jitter and the spurs on the phase noise plot can be interpreted as deterministic jitter. Total RMS Phase Jitter includes both random and deterministic jitter.

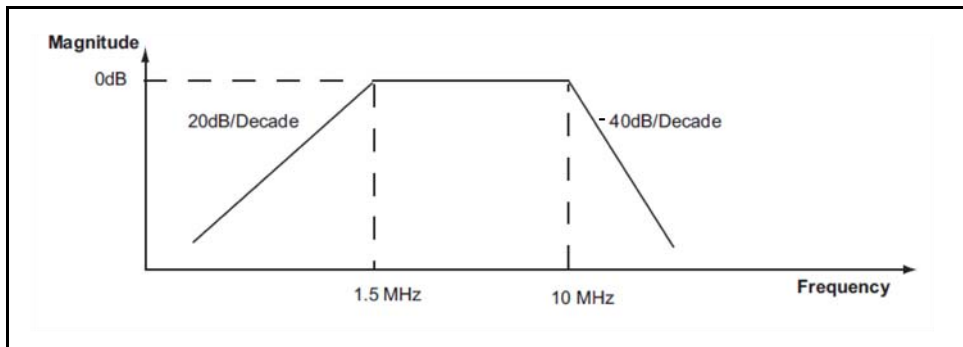

Figure 7. Weighing Function for Jitter Calculation

## Network Processor Core Clocks and High Speed PLLs Application Note

The Network Processor Core clocks and High Speed PLLs jitter analysis models the system response to reference clock jitter. Network Processors typically have internal high speed PLLs that scale external reference core clocks 10x, 20x and 40x the input frequency. In this jitter analysis, the high speed PLLs internal to the processors are modeled by the transfer response function shown in *Figure 8*. A phase noise measurement is executed and a frequency domain analysis is performed. In the phase noise plot, the high speed PLL transfer function is masked on the reference clock. The area under the resultant phase noise curve is referred to as Phase Jitter. In the frequency domain, the random and deterministic jitter can be calculated quickly and accurately. RMS Phase Jitter is also referred to as random jitter and the spurs on the phase noise plot can be interpreted as deterministic jitter. Total Phase Jitter includes both Random and Deterministic jitter. The Total Jitter can then be calculated using a desired bit error rate (BER). For additional information on calculating Total Jitter refer to the *Peak-to-Peak Jitter Calculations* section.

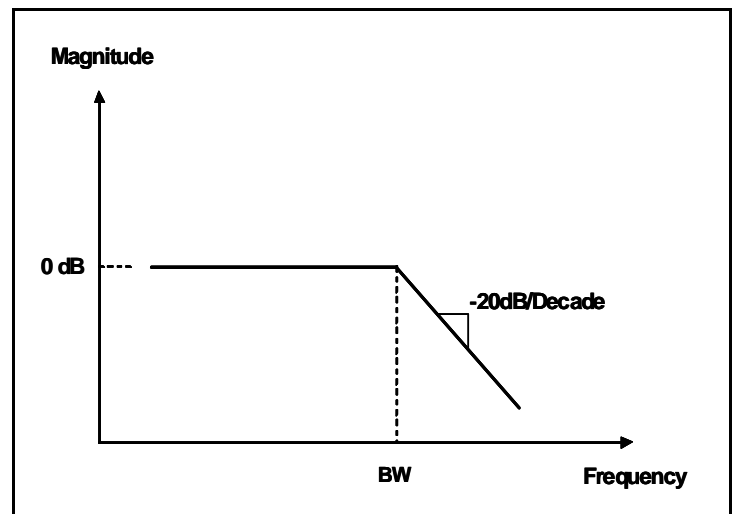

Figure 8. Weighing Function for Jitter Calculation

## Power Considerations

This section provides information on power dissipation and junction temperature for the 8413S12B. Equations and example calculations are also provided.

### 1. Power Dissipation.

The total power dissipation for the 8413S12B is the sum of the core power plus the output power dissipated due to the loading. The following is the power dissipation for  $V_{DD} = 3.3V + 5\% = 3.465V$ , which gives worst case results.

NOTE: Please refer to Section 3 for details on calculating output power dissipated due to the loading.

- Power (core)<sub>MAX</sub> =  $V_{DD\_MAX} * (I_{DD} + I_{DDA}) = 3.465V * (103mA + 16mA) = \mathbf{412.3mW}$
- Power (HCSL)<sub>MAX</sub> =  $(3.465V - 17mA * 50) 17mA = \mathbf{44.5mW}$  per output
- Total Power (HCSL)<sub>MAX</sub> =  $44.5mW * 10 = \mathbf{445mW}$

#### LVC MOS Driver Power Dissipation

- Output Impedance  $R_{OUT}$  Power Dissipation due to Loading  $50\Omega$  to  $V_{DD}/2$   
Output Current  $I_{OUT} = V_{DD\_MAX} / [2 * (50\Omega + R_{OUT})] = 3.465V / [2 * (50\Omega + 15\Omega)] = \mathbf{27mA}$
- Power Dissipation on the  $R_{OUT}$  per LVC MOS output  
Power (LVC MOS) =  $R_{OUT} * (I_{OUT})^2 = 15\Omega * (27mA)^2 = \mathbf{11mW}$  per output
- Total Power Dissipation on the  $R_{OUT}$   
**Total Power ( $R_{OUT}$ ) =  $11mW * 4 = \mathbf{44mW}$**

Total Power Dissipation

- **Total Power**  
= Power (core) + Total Power (HCSL) + Total Power ( $R_{OUT}$ )  
=  $412.3mW + 445mW + 44mW$   
= **901.3mW**

### 2. Junction Temperature.

Junction temperature,  $T_j$ , is the temperature at the junction of the bond wire and bond pad directly affects the reliability of the device. The maximum recommended junction temperature is  $125^\circ\text{C}$ . Limiting the internal transistor junction temperature,  $T_j$ , to  $125^\circ\text{C}$  ensures that the bond wire and bond pad temperature remains below  $125^\circ\text{C}$ .

The equation for  $T_j$  is as follows:  $T_j = \theta_{JA} * Pd\_total + T_A$

$T_j$  = Junction Temperature

$\theta_{JA}$  = Junction-to-Ambient Thermal Resistance

$Pd\_total$  = Total Device Power Dissipation (example calculation is in section 1 above)

$T_A$  = Ambient Temperature

In order to calculate junction temperature, the appropriate junction-to-ambient thermal resistance  $\theta_{JA}$  must be used. Assuming no air flow and a multi-layer board, the appropriate value is  $25.4^\circ\text{C/W}$  per Table 9 below.

Therefore,  $T_j$  for an ambient temperature of  $85^\circ\text{C}$  with all outputs switching is:

$$85^\circ\text{C} + 0.901\text{W} * 25.4^\circ\text{C/W} = 108^\circ\text{C}. \text{ This is below the limit of } 125^\circ\text{C}.$$

This calculation is only an example.  $T_j$  will obviously vary depending on the number of loaded outputs, supply voltage, air flow and the type of board (multi-layer).

**Table 9. Thermal Resistance  $\theta_{JA}$  for 72 Lead VFQFN, Forced Convection**

$\theta_{JA}$ vs. Air Flow			
Meters per Second	0	1	2.5
Multi-Layer PCB, JEDEC Standard Test Boards	$25.4^\circ\text{C/W}$	$20.5^\circ\text{C/W}$	$18.4^\circ\text{C/W}$

### 3. Calculations and Equations.

The purpose of this section is to calculate power dissipation on the IC per HCSL output pair.

HCSL output driver circuit and termination are shown in *Figure 9*.

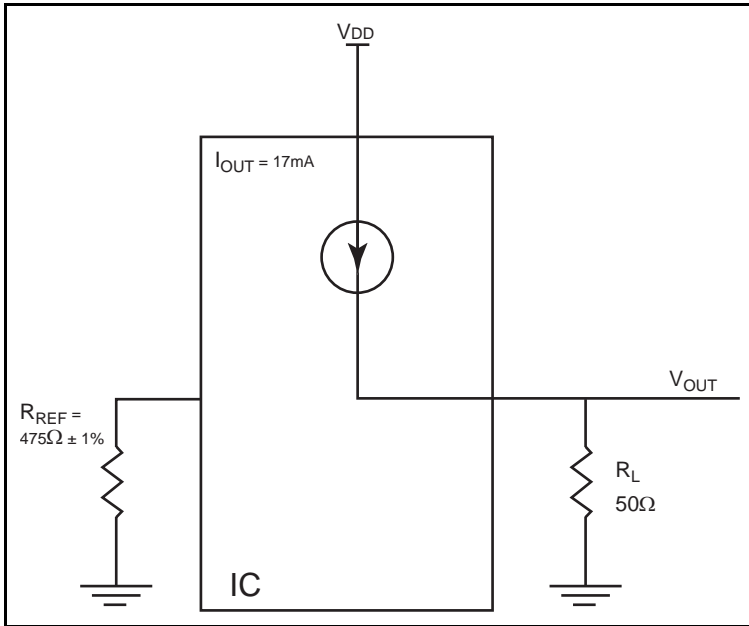

**Figure 9. HCSL Driver Circuit and Termination**

HCSL is a current steering output which sources a maximum of 17mA of current per output. To calculate on-chip output power dissipation due to the loading, use the following equations which assume a 50Ω load to ground.

The highest power dissipation occurs when  $V_{DD\_MAX}$ .

$$\text{Power} = (V_{DD\_MAX} - V_{OUT}) * I_{OUT}$$

$$\text{since } V_{OUT} = I_{OUT} * R_L$$

$$\text{Power} = (V_{DD\_MAX} - I_{OUT} * R_L) * I_{OUT}$$

$$= (3.465V - 17mA * 50\Omega) * 17mA$$

Total Power Dissipation per output pair = **44.5mW**

## Reliability Information

Table 10.  $\theta_{JA}$  vs. Air Flow Table for a 72 Lead VFQFN

$\theta_{JA}$ vs. Air Flow			
Meters per Second	0	1	2.5
Multi-Layer PCB, JEDEC Standard Test Boards	25.4°C/W	20.5°C/W	18.4°C/W

## Transistor Count

The transistor count for 8413S12B is: 10,297

## Package Outline and Package Dimensions

Table 11. Package Dimensions - 72 Lead VFQFN

All Dimensions in Millimeters			
Symbol	Minimum	Nominal	Maximum
N		72	
A	0.80	0.90	1.00
A1	0	0.02	0.05
A2	0.58	0.65	1.00
A3		0.20 Ref.	
b	0.18	0.25	0.30
$N_D$ & $N_E$			18
D & E		10.00 Basic	
D1 & E1		9.75 Basic	
D2 & E2	5.50	6.00	6.60
e		0.50 Basic	
$\theta$	8°	10°	12°
L	0.30	0.40	0.50
R (ref)	b min/2		
R1		0.20	
T		0.45 Ref.	
aaa			0.15
bbb			0.10
ccc			0.10
ddd			0.05
$\ominus$	0		14

Reference Document: PSC-4111

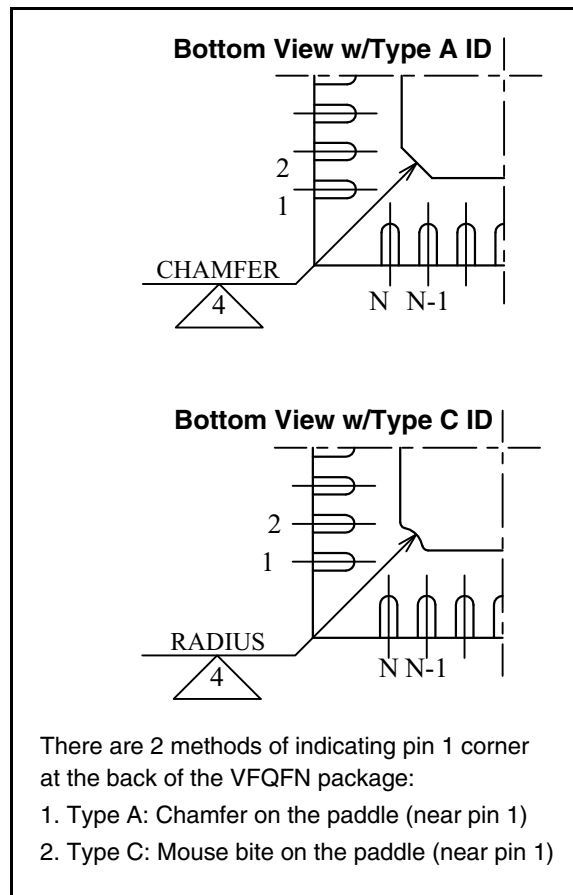

# Package Outline

## Package Outline - K Suffix for 72 Lead VFQFN

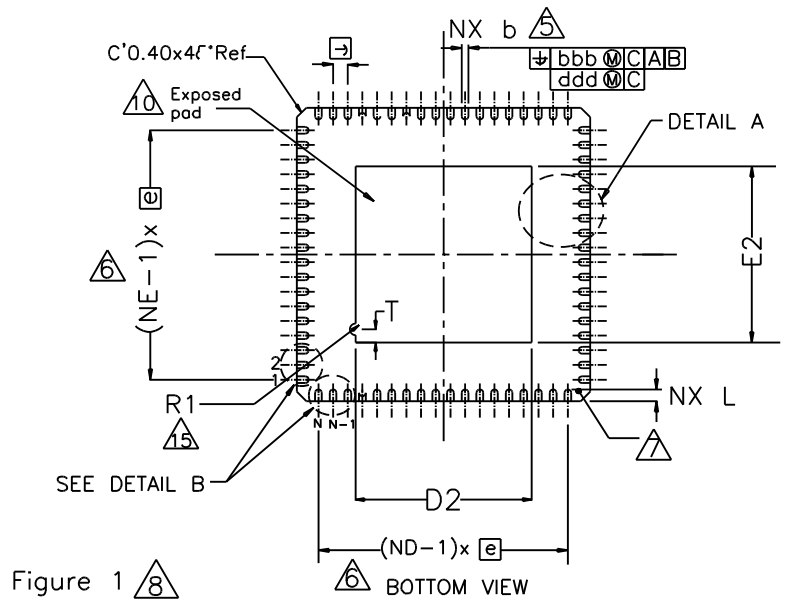
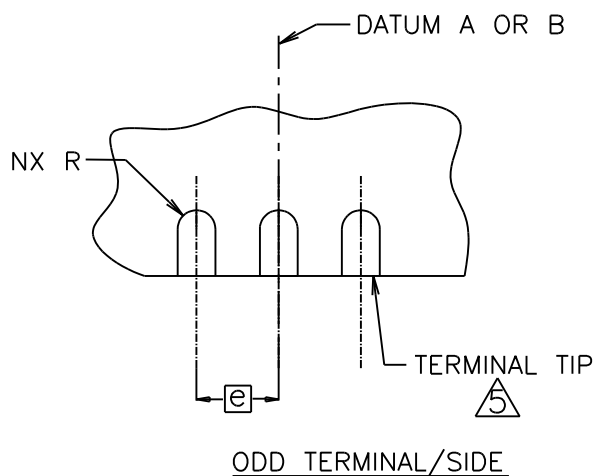
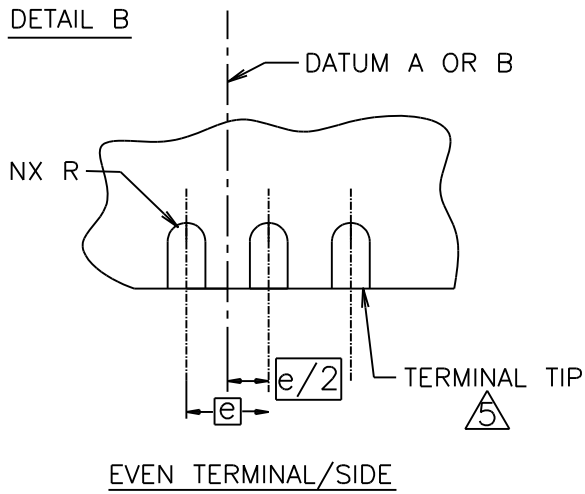
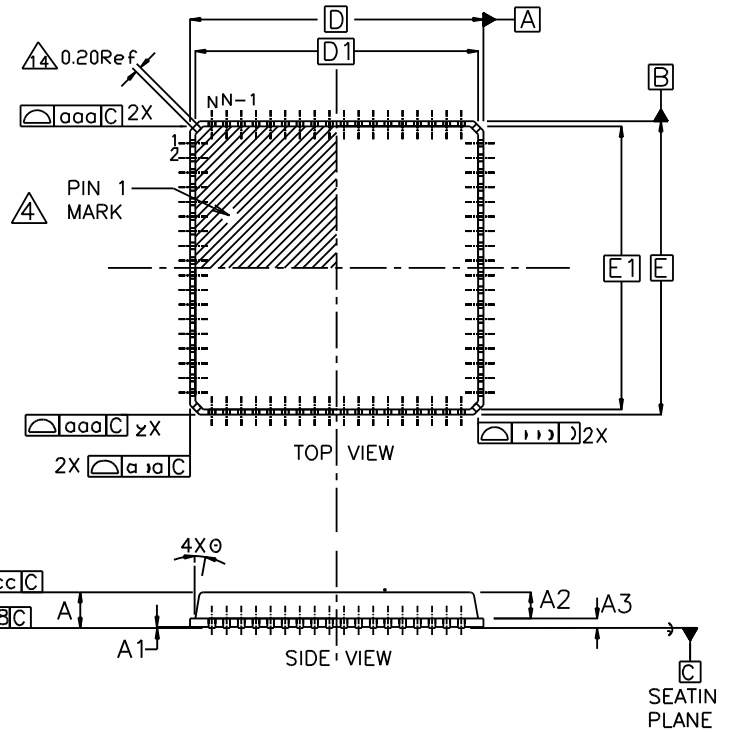
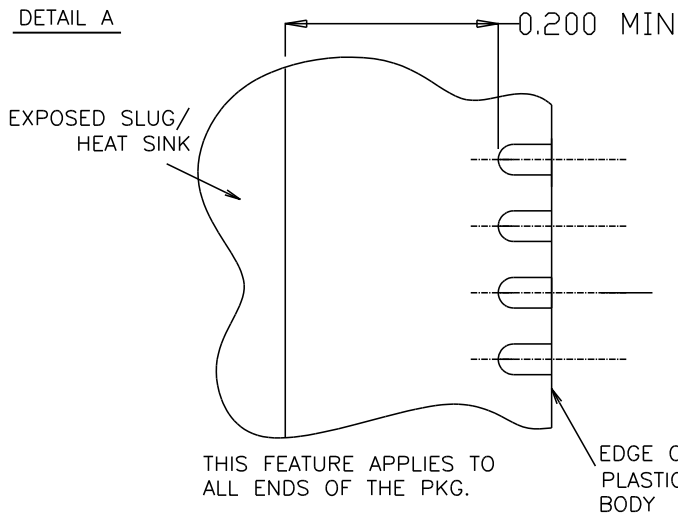

Figure 1

## Ordering Information

Table 11. Ordering Information

Part/Order Number	Marking	Package	Shipping Packaging	Temperature
8413S12BKILF	ICS8413S12BKILF	Lead-Free, 72 Lead VFQFN	Tray	-40°C to 85°C
8413S12BKILFT	ICS8413S12BKILF	Lead-Free, 72 Lead VFQFN	Tape & Reel	-40°C to 85°C

## Revision History Sheet

Rev	Table	Page	Description of Change	Date
B	T7E	2	Block Diagram - corrected CLK labeling from pullup to pulldown.	6/22/2011
		10	AC Characteristics Table - added RMS Phase Jitter specs. Updated $D_J$ spec for QE output from 60ps typ. / 100ps max. to 60ps typ. / 85ps max.	
	T7F - T7G	10 - 11	AC Characteristics Tables - added RMS Phase Jitter specs.	
	T7H	12	AC Characteristics Table - updated RMS Phase Jitter max. spec from 0.77ps to 0.96ps; $t_R / t_F$ QREF max. spec from 1700ps to 1400ps; odc QF and QREF specs from 42% min. - 58% max. to 45% min. to 55% max.	
		13	Added Phase Noise Plot.	
		30 - 33	Updated Package Information.	
B		1	Deleted Cavium process from the General Description and Applications sections, and change title headers on each page.	3/20/2012
B		1 30	General Description, deleted references to CN6XXX requirements. Change IDT package information to ICS package information.	3/23/2012
C	T1	2	Per Errata NEN-12-04: Block Diagram - corrected nMR label from Pulldown to Pullup.	12/19/2012
		4	Pin Description Table - Pin 62, changed pulldown to pullup, In the Description, changed 'nQX to go low' to 'nQX to go high'.	
	T4C	7	LVC MOS DC Characteristics Table - $I_{IH}$ moved nMR pin to spec 10 $\mu$ A max. $I_{IL}$ moved nMR pin to spec -150 $\mu$ A min.	
	T11	18	Updated <i>Wiring the Differential Input to Accept Single-Ended Levels</i> application note.	
31		Ordering Information Table - deleted tape & reel count.		
C		23-24	Replaced Schematic and text	2/7/2014
D	T1	1	Re-formatted Pin Assignment. No changes to the pins.	1/27/2015
		2	Corrected Block Diagram, and added note.	
		4	Pin Description Table - Pin 62, nMR, corrected description. Deleted "ICS" prefix from the part number throughout the datasheet. Updated header/footer throughout the datasheet.	
E			Changed part number from 8413S12 to 8413S12B. Updated header/footer throughout the datasheet.	8/18/16



## IMPORTANT NOTICE AND DISCLAIMER

RENESAS ELECTRONICS CORPORATION AND ITS SUBSIDIARIES (“RENESAS”) PROVIDES TECHNICAL SPECIFICATIONS AND RELIABILITY DATA (INCLUDING DATASHEETS), DESIGN RESOURCES (INCLUDING REFERENCE DESIGNS), APPLICATION OR OTHER DESIGN ADVICE, WEB TOOLS, SAFETY INFORMATION, AND OTHER RESOURCES “AS IS” AND WITH ALL FAULTS, AND DISCLAIMS ALL WARRANTIES, EXPRESS OR IMPLIED, INCLUDING, WITHOUT LIMITATION, ANY IMPLIED WARRANTIES OF MERCHANTABILITY, FITNESS FOR A PARTICULAR PURPOSE, OR NON-INFRINGEMENT OF THIRD-PARTY INTELLECTUAL PROPERTY RIGHTS.

These resources are intended for developers who are designing with Renesas products. You are solely responsible for (1) selecting the appropriate products for your application, (2) designing, validating, and testing your application, and (3) ensuring your application meets applicable standards, and any other safety, security, or other requirements. These resources are subject to change without notice. Renesas grants you permission to use these resources only to develop an application that uses Renesas products. Other reproduction or use of these resources is strictly prohibited. No license is granted to any other Renesas intellectual property or to any third-party intellectual property. Renesas disclaims responsibility for, and you will fully indemnify Renesas and its representatives against, any claims, damages, costs, losses, or liabilities arising from your use of these resources. Renesas' products are provided only subject to Renesas' Terms and Conditions of Sale or other applicable terms agreed to in writing. No use of any Renesas resources expands or otherwise alters any applicable warranties or warranty disclaimers for these products.

(Disclaimer Rev.1.01 Jan 2024)

### Corporate Headquarters

TOYOSU FORESIA, 3-2-24 Toyosu,  
Koto-ku, Tokyo 135-0061, Japan  
[www.renesas.com](http://www.renesas.com)

### Trademarks

Renesas and the Renesas logo are trademarks of Renesas Electronics Corporation. All trademarks and registered trademarks are the property of their respective owners.

### Contact Information

For further information on a product, technology, the most up-to-date version of a document, or your nearest sales office, please visit [www.renesas.com/contact-us/](http://www.renesas.com/contact-us/).

## Looking for pricing, stock, or lifecycle information?

Click below to explore more details on WIN SOURCE:

-  [View 8413S12BKILF on WIN SOURCE](#)
-  [Renesas Electronics America](#) Information

## Optimize Your Supply Chain with WIN SOURCE Solutions

-  Global Sourcing Solution
-  Obsolete Management
-  Cost Control Management
-  Shortage Management
-  Alternative Solution
-  Excess Inventory Management