



**THE DATASHEET OF**  
**843N571BKILF**



## Description

The 843N5711 is a PLL based clock synthesizer for use in Ethernet applications. The device uses IDT's fourth generation FemtoClock® NG technology for optimal high clock frequency and low phase noise performance, combined with a low power consumption and high power supply noise rejection. Using IDT's latest FemtoClock NG PLL technology, the 843N5711 achieves <0.3ps RMS phase jitter performance.

843N5711 can synthesize 100MHz, 125MHz, 156.25MHz and a low frequency 33.33MHz CPU clock from a single device. Six LVCMOS outputs also serve as additional buffering of the 25MHz crystal reference.

## Features

- Fourth generation FemtoClock® Next Generation (NG) technology
- Seven single-ended LVCMOS outputs, 30Ω output impedance
- Three LVPECL output pairs  
One differential LVPECL (QA, nQA) output pair: 156.25MHz  
Two selectable differential LVPECL output pairs (QB, nQB and QC, nQC): 100MHz and 125MHz
- One single-ended LVCMOS (QD0) 33.33MHz CPU clock
- Selectable external crystal or single-ended input source
- Crystal oscillator interface designed for 25MHz, parallel resonant crystal
- FemtoClock NG frequency multiplier provides low jitter, high frequency output
- FemtoClock NG VCO frequency: 2.5GHz
- RMS phase jitter @ 125MHz, using a 25MHz crystal (12kHz – 20MHz): 0.283ps (typical)
- Power supply noise rejection PSNR: -80dB
- 3.3V supply voltage
- -40C to 85C ambient operating temperature
- Lead-free (RoHS 6) packaging

## Pin Assignment

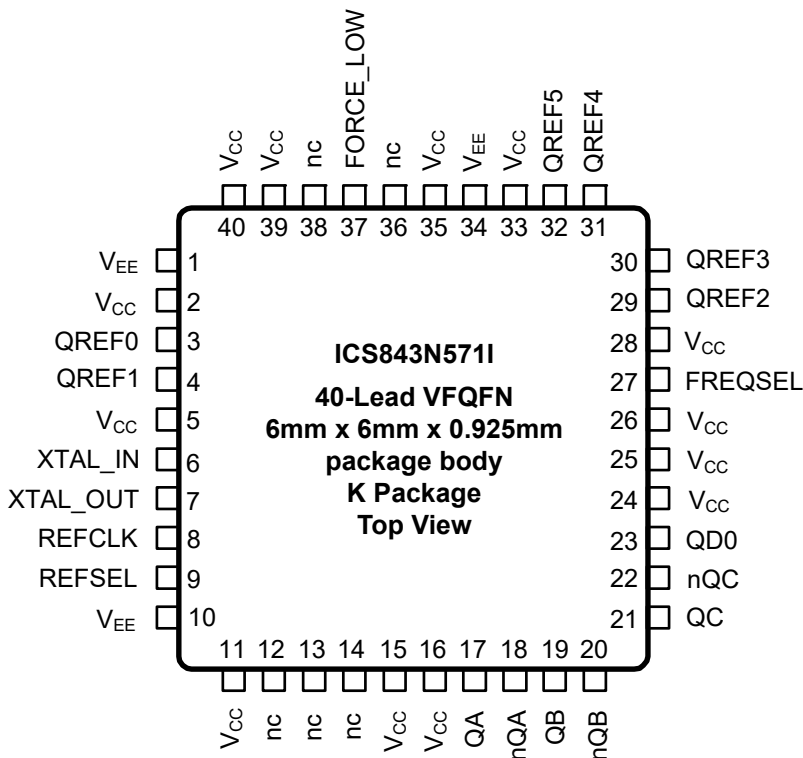

# Block Diagram

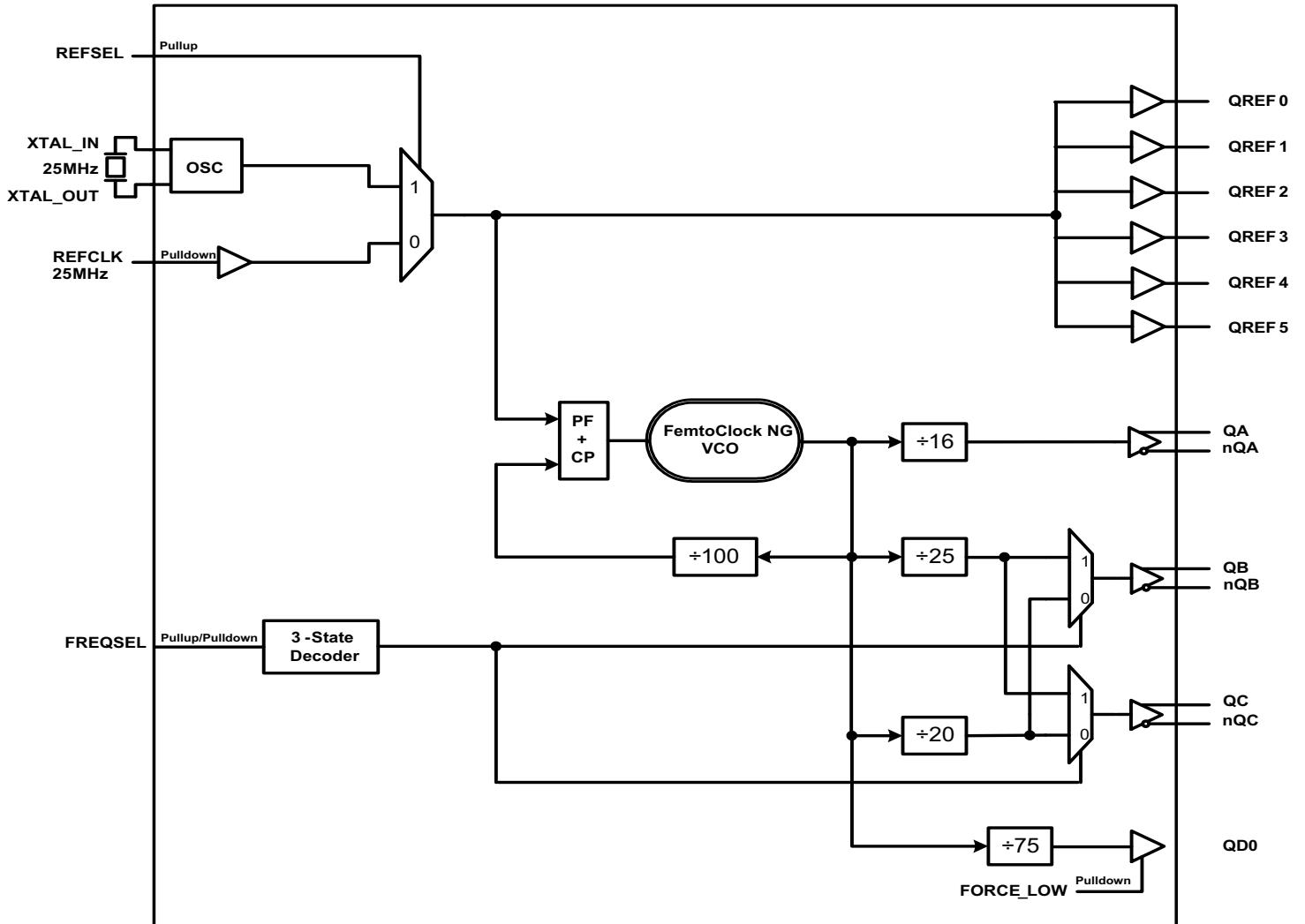

## Pin Description and Pin Characteristic Tables

**Table 1. Pin Descriptions**

Number	Name	Type		Description
1, 10, 34	V <sub>EE</sub>	Power		Negative supply pins.
2, 5, 11, 15, 16, 24, 25, 26, 28, 33, 35, 39, 40	V <sub>CC</sub>	Power		Power supply pins. Pins 2, 28, 33 – power supply connection for the 25MHz LVCMOS outputs Pin 5 – power supply connection for the crystal oscillator Pins 11, 15, 26, 35 – power supply connection for the dividers and other core circuitry Pin 16 (vposO) – power supply connection for the differential LVPECL outputs Pin 24, 25 – power supply connection for the 33MHz LVCMOS output Pin 39 – power supply connection for the digital logic Pin 40 – power supply connection for the PLL
3, 4, 29, 30, 31, 32	QREF0, QREF1, QREF2, QREF3, QREF4, QREF5	Output		Single-ended outputs. 3.3V LVCMOS/LVTTL reference levels.
6, 7	XTAL_IN, XTAL_OUT	Input		Parallel resonant crystal interface. XTAL_OUT is the output, XTAL_IN is the input.
8	REFCLK	Input	Pulldown	Single-ended LVCMOS/LVTTL reference clock input.
9	REFSEL	Input	Pullup	Reference select pin. When HIGH, selects crystal. When LOW, selects REFCLK. See Table 3A. LVCMOS/LVTTL interface levels.
12, 13, 14, 36, 38	nc			No connect.
17, 18	QA, nQA	Output		Differential output pair. LVPECL interface levels.
19, 20	QB, nQB	Output		Differential output pair. LVPECL interface levels.
21, 22	QC, nQC	Output		Differential output pair. LVPECL interface levels.
23	QD0	Output		Single-ended output. 3.3V LVCMOS/LVTTL reference levels.
27	FREQSEL	Input	Pullup/ Pulldown	Frequency select pin. See Table 3B. LVCMOS/LVTTL interface levels.
37	FORCE_LOW	Input	Pulldown	Forces the QD0 output into a low state. See Table 3C. LVCMOS/LVTTL interface levels.

NOTE: Pullup and Pulldown refer to internal input resistors. See Table 2, Pin Characteristics, for typical values.

**Table 2. Pin Characteristics**

Symbol	Parameter		Test Conditions	Minimum	Typical	Maximum	Units
C <sub>IN</sub>	Input Capacitance		Crystal Not Included		2		pF
C <sub>PD</sub>	Power Dissipation Capacitance (per output)	QD0, QREF[0:5]	V <sub>CC</sub> = 3.6V		6		pF
R <sub>PULLUP</sub>	Input Pullup Resistor				51		kΩ
R <sub>PULLDOWN</sub>	Input Pulldown Resistor				51		kΩ
R <sub>OUT</sub>	Output Impedance	QD0, QREF[0:5]			30		Ω

## Function Tables

**Table 3A. REFSEL Function Table**

Inputs	Input Source
<b>REFSEL</b>	
0	REFCLK
1 (default)	XTAL_IN, XTAL_OUT

**Table 3C. FORCE\_LOW Function Table**

Inputs	Output Frequency (MHz)
<b>FORCE_LOW</b>	<b>QD0</b>
0 (default)	33.33
1	Disabled

**Table 3B. FREQSEL Function Table**

Inputs	Output Frequency (MHz)	
	QB, nQB	QC, nQC
0	125	125
1	100	100
Float (default)	125	100

## Absolute Maximum Ratings

Exposure to absolute maximum rating conditions for extended periods may affect product reliability. Stresses beyond those listed under *Absolute Maximum Ratings* may cause permanent damage to the device. These ratings are stress specifications only. Functional operation of product at these conditions or any conditions beyond those listed in the *DC Characteristics* or *AC Characteristics* is not implied.

Item	Rating
Supply Voltage, $V_{CC}$	3.63V
Inputs, $V_I$ XTAL_IN Other Inputs	0V to 2V -0.5V to $V_{CC} + 0.5V$
Outputs, $I_O$ (LVCMOS)	-0.5V to $V_{CC} + 0.5V$
Outputs, $I_O$ (LVPECL) Continuous Current Surge Current	50mA 100mA
Package Thermal Impedance, $\theta_{JA}$	37.7°C/W (0 mps)
Maximum Junction Temperature, $T_{J,MAX}$	150°C
Storage Temperature, $T_{STG}$	-65°C to 150°C

## Recommended Operating Conditions

Symbol	Parameter	Minimum	Typical	Maximum	Units
$T_A$	Ambient air temperature	-40		85	°C
$T_J$	Junction temperature			125	°C

NOTE 1: It is the user's responsibility to ensure that device junction temperature remains below the maximum allowed.

NOTE 2: All conditions in the table must be met to guarantee device functionality.

NOTE 3: The device is verified to the maximum operating junction temperature through simulation.

## DC Electrical Characteristics

**Table 4A. Power Supply DC Characteristics,  $V_{CC} = 3.3V \pm 0.3V$ ,  $V_{EE} = 0V$ ,  $T_A = -40^\circ C$  to  $85^\circ C$**

Symbol	Parameter	Test Conditions	Minimum	Typical	Maximum	Units
$V_{CC}$	Power Supply Voltage		3.0	3.3	3.6	V
$I_{EE}$	Power Supply Current	No Load			250	mA

**Table 4B. LVCMOS/LVTTL DC Characteristics,  $V_{CC} = 3.3V \pm 0.3V$ ,  $T_A = -40^\circ C$  to  $85^\circ C$**

Symbol	Parameter	Test Conditions	Minimum	Typical	Maximum	Units
$V_{IH}$	Input High Voltage	REFSEL, FORCE_LOW	2		$V_{CC} + 0.3$	V
		FREQSEL	$V_{CC} - 0.4$			V
$V_{IL}$	Input Low Voltage	REFSEL, FORCE_LOW	-0.3		0.8	V
		FREQSEL			0.4	V
$V_{IM}$	Input Medium Voltage	FREQSEL	$V_{CC}/2 - 0.1$		$V_{CC}/2 + 0.1$	V

Symbol	Parameter		Test Conditions	Minimum	Typical	Maximum	Units
$I_{IH}$	Input High Current	REFCLK, FREQSEL, FORCE_LOW	$V_{CC} = V_{IN} = 3.6V$			150	$\mu A$
		REFSEL	$V_{CC} = V_{IN} = 3.6V$			5	$\mu A$
$I_{IL}$	Input Low Current	REFCLK, FORCE_LOW	$V_{CC} = 3.6V, V_{IN} = 0V$	-5			$\mu A$
		REFSEL, FREQSEL	$V_{CC} = 3.6V, V_{IN} = 0V$	-150			$\mu A$
$V_{OH}$	Output High Voltage; NOTE 1		$V_{CC} = 3.3V \pm 0.3V$	2.3			V
$V_{OL}$	Output Low Voltage; NOTE 1		$V_{CC} = 3.3V \pm 0.3V$			0.8	V

NOTE 1: Outputs terminated with  $50\Omega$  to  $V_{CC}/2$ . See Parameter Measurement Information, *Output Load Test Circuit diagrams*.

**Table 4C. LVPECL DC Characteristics,  $V_{CC} = 3.3V \pm 0.3V, V_{EE} = 0V, T_A = -40^\circ C$  to  $85^\circ C$**

Symbol	Parameter	Test Conditions	Minimum	Typical	Maximum	Units
$V_{OH}$	Output High Voltage; NOTE 1		$V_{CC} - 1.4$		$V_{CC} - 0.8$	V
$V_{OL}$	Output Low Voltage; NOTE 1		$V_{CC} - 2.0$		$V_{CC} - 1.6$	V
$V_{SWING}$	Peak-to-Peak Output Voltage Swing		0.6		1.0	V

NOTE 1: Outputs terminated with  $50\Omega$  to  $V_{CC} - 2V$ .

**Table 5. Crystal Characteristics**

Parameter	Test Conditions	Minimum	Typical	Maximum	Units
Mode of Oscillation		Fundamental			
Frequency			25		MHz
Equivalent Series Resistance (ESR)				50	$\Omega$
Shunt Capacitance				7	pF

## AC Electrical Characteristics

**Table 6A. LVPECL AC Characteristics,  $V_{CC} = 3.3V \pm 0.3V, V_{EE} = 0V, T_A = -40^\circ C$  to  $85^\circ C$**

Symbol	Parameter	Test Conditions	Minimum	Typical	Maximum	Units
$f_{IN}$	Input Frequency			25		MHz
$f_{OUT}$	Output Frequency		100		156.25	MHz

Symbol	Parameter		Test Conditions	Minimum	Typical	Maximum	Units
tjit( $\theta$ )	RMS Phase Jitter (Random) NOTE 1		156.25MHz f <sub>OUT</sub> , 25MHz crystal Integration Range: 12kHz – 20MHz		0.233		ps
			125MHz f <sub>OUT</sub> , 25MHz crystal Integration Range: 12kHz – 20MHz		0.283		ps
			100MHz f <sub>OUT</sub> , 25MHz crystal Integration Range: 12kHz – 20MHz		0.299		ps
tsk(o)	Output Skew; NOTE 2, 3		Measured on the Rising Edge			40	ps
PSNR	Power Supply Noise Reduction	Pin 40 (V <sub>CC</sub> )	From DC to 8MHz, FORCE_LOW = HIGH		-75		dB
		Pin 40 (V <sub>CC</sub> )	From DC to 3MHz, FORCE_LOW = LOW		-80		dB
t <sub>R</sub> / t <sub>F</sub>	Output Rise/Fall Time		20% to 80%	150		550	ps
odc	Output Duty Cycle			48		52	%

NOTE: Electrical parameters are guaranteed over the specified ambient operating temperature range, which is established when the device is mounted in a test socket with maintained transverse airflow greater than 500 lfpm. The device will meet specifications after thermal equilibrium has been reached under these conditions

NOTE 1: Refer to the Phase Noise Plot.

NOTE 2: This parameter is defined in accordance with JEDEC Standard 65.

NOTE 3: Defined as skew between outputs at the same supply voltage and with equal load conditions. Measured at the differential crosspoints.

**Table 6B. AC Characteristics for Single Side Band Power Levels (LVPECL Outputs),**

V<sub>CC</sub> = 3.3V ± 0.3V, V<sub>EE</sub> = 0V, T<sub>A</sub> = 25°C

Symbol	Parameter	Test Conditions	Minimum	Typical	Maximum	Units
Φ <sub>N</sub> (1k)	Single-side band phase noise, 1kHz from Carrier	156.25MHz, 33.33MHz Output disabled		-120		dBc/Hz
Φ <sub>N</sub> (10k)	Single-side band phase noise, 10kHz from Carrier			-132		dBc/Hz
Φ <sub>N</sub> (100k)	Single-side band phase noise, 100kHz from Carrier			-135		dBc/Hz
Φ <sub>N</sub> (1M)	Single-side band phase noise, 1MHz from Carrier			-140		dBc/Hz
Φ <sub>N</sub> (10M)	Single-side band phase noise, 10MHz from Carrier			-156		dBc/Hz
Φ <sub>N</sub> (20M)	Single-side band phase noise, 20MHz from Carrier			-157		dBc/Hz

Symbol	Parameter	Test Conditions	Minimum	Typical	Maximum	Units
$\Phi_N(1k)$	Single-side band phase noise, 1kHz from Carrier	125MHz, 33.33MHz Output disabled		-121		dBc/Hz
$\Phi_N(10k)$	Single-side band phase noise, 10kHz from Carrier			-133		dBc/Hz
$\Phi_N(100k)$	Single-side band phase noise, 100kHz from Carrier			-137		dBc/Hz
$\Phi_N(1M)$	Single-side band phase noise, 1MHz from Carrier			-143		dBc/Hz
$\Phi_N(10M)$	Single-side band phase noise, 10MHz from Carrier			-153		dBc/Hz
$\Phi_N(20M)$	Single-side band phase noise, 20MHz from Carrier			-153		dBc/Hz
$\Phi_N(1k)$	Single-side band phase noise, 1kHz from Carrier	100MHz, 33.33MHz Output disabled		-123		dBc/Hz
$\Phi_N(10k)$	Single-side band phase noise, 10kHz from Carrier			-135		dBc/Hz
$\Phi_N(100k)$	Single-side band phase noise, 100kHz from Carrier			-139		dBc/Hz
$\Phi_N(1M)$	Single-side band phase noise, 1MHz from Carrier			-145		dBc/Hz
$\Phi_N(10M)$	Single-side band phase noise, 10MHz from Carrier			-154		dBc/Hz
$\Phi_N(20M)$	Single-side band phase noise, 20MHz from Carrier			-154		dBc/Hz

NOTE: Electrical parameters are guaranteed over the specified ambient operating temperature range, which is established when the device is mounted in a test socket with maintained transverse airflow greater than 500 lfpm. The device will meet specifications after thermal equilibrium has been reached under these conditions.

**Table 6C. LVCMOS AC Characteristics,  $V_{CC} = 3.3V \pm 0.3V$ ,  $T_A = -40^\circ C$  to  $85^\circ C$**

Symbol	Parameter	Test Conditions	Minimum	Typical	Maximum	Units
$f_{IN}$	Input Frequency			25		MHz
$f_{OUT}$	Output Frequency		25		33.33	MHz
$t_{jit}(\theta)$	RMS Phase Jitter (Random) NOTE 1	33.33MHz $f_{OUT}$ , 25MHz crystal Integration Range: 12kHz – 5MHz		0.266		ps
		25MHz $f_{OUT}$ , 25MHz crystal Integration Range: 12kHz – 5MHz		0.212		ps
$t_{sk(o)}$	Output Skew; NOTE 2, 3	QREF[0:5] Measured on the Rising Edge			50	ps
PSNR	Power Supply Noise Reduction	Pin 40, ( $V_{CC}$ ) From DC to 6.25MHz		-80		dB
$t_R / t_F$	Output Rise/Fall Time	20% to 80%	200		600	ps
odc	Output Duty Cycle		48		52	%

NOTE: Electrical parameters are guaranteed over the specified ambient operating temperature range, which is established when the device is mounted in a test socket with maintained transverse airflow greater than 500 lfpm. The device will meet specifications after thermal equilibrium has been reached under these conditions

NOTE 1: Refer to the Phase Noise Plot.

NOTE 2: This parameter is defined in accordance with JEDEC Standard 65.

NOTE 3: Defined as skew between outputs at the same supply voltage and with equal load conditions. Measured at  $V_{CC}/2$ .

**Table 6D. AC Characteristics for Single Side Band Power Levels (LVCMOS Outputs),**

$V_{CC} = 3.3V \pm 0.3V$ ,  $V_{EE} = 0V$ ,  $T_A = 25^\circ C$

Symbol	Parameter	Test Conditions	Minimum	Typical	Maximum	Units
$\Phi_N(1k)$	Single-side band phase noise, 1kHz from Carrier	33.33MHz		-134		dBc/Hz
$\Phi_N(10k)$	Single-side band phase noise, 10kHz from Carrier			-144		dBc/Hz
$\Phi_N(100k)$	Single-side band phase noise, 100kHz from Carrier			-149		dBc/Hz
$\Phi_N(1M)$	Single-side band phase noise, 1MHz from Carrier			-153		dBc/Hz
$\Phi_N(5M)$	Single-side band phase noise, 5MHz from Carrier			-159		dBc/Hz
$\Phi_N(1k)$	Single-side band phase noise, 1kHz from Carrier	25MHz		-137		dBc/Hz
$\Phi_N(10k)$	Single-side band phase noise, 10kHz from Carrier			-152		dBc/Hz
$\Phi_N(100k)$	Single-side band phase noise, 100kHz from Carrier			-158		dBc/Hz
$\Phi_N(1M)$	Single-side band phase noise, 1MHz from Carrier			-160		dBc/Hz
$\Phi_N(5M)$	Single-side band phase noise, 5MHz from Carrier			-160		dBc/Hz

NOTE: Electrical parameters are guaranteed over the specified ambient operating temperature range, which is established when the device is mounted in a test socket with maintained transverse airflow greater than 500 lfpm. The device will meet specifications after thermal equilibrium has been reached under these conditions.

### Typical Phase Noise at 25MHz (LVCMOS Output)

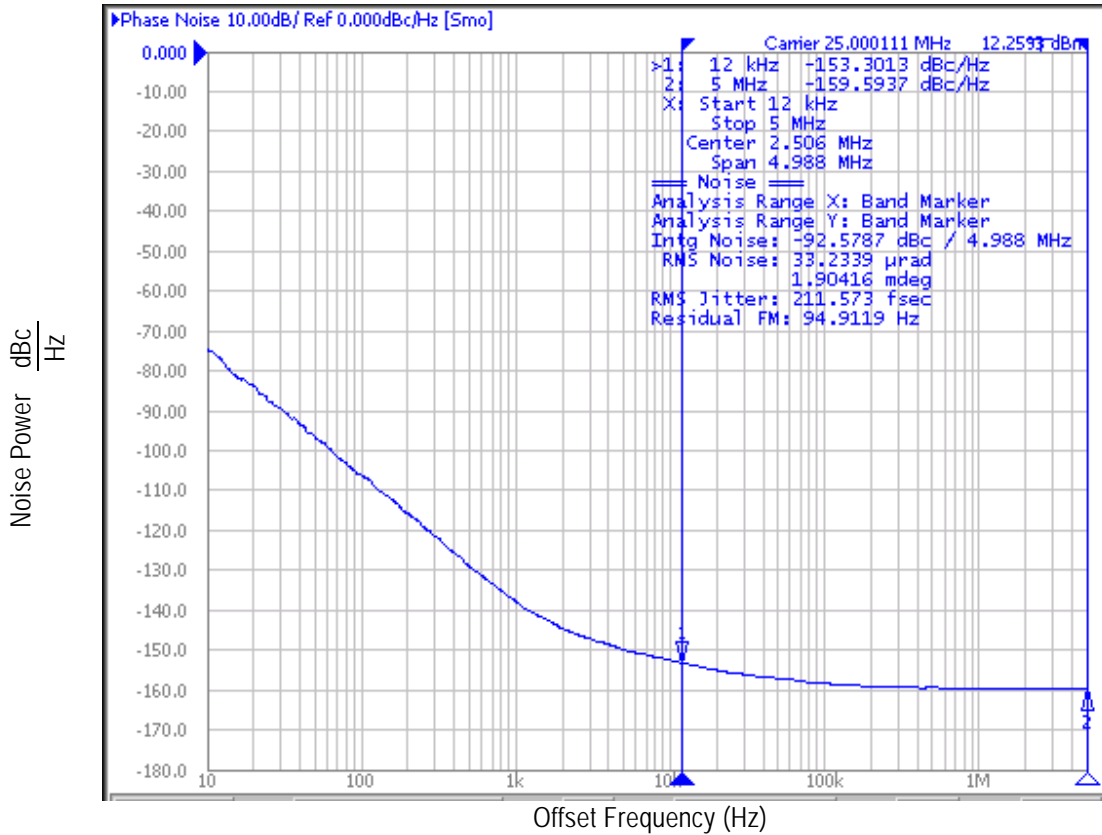

### Typical Phase Noise at 33.33MHz (LVCMOS Output)

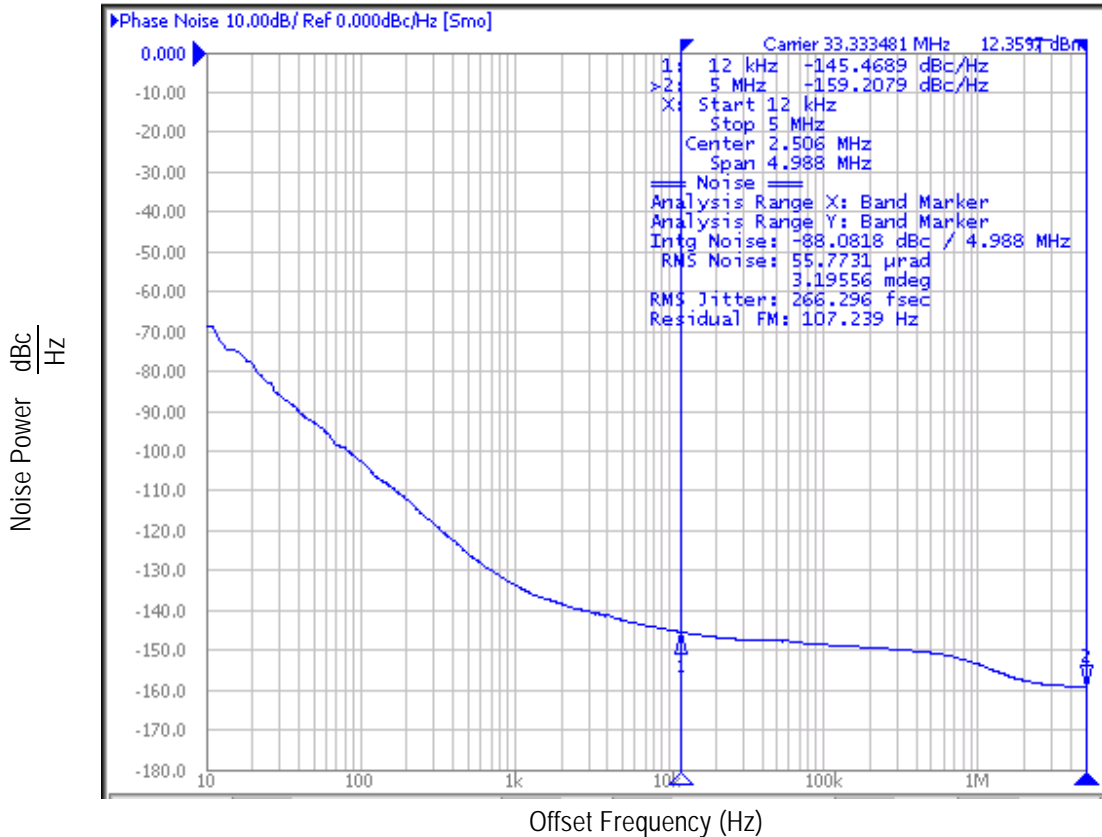

### Typical Phase Noise at 100MHz (LVPECL Output)

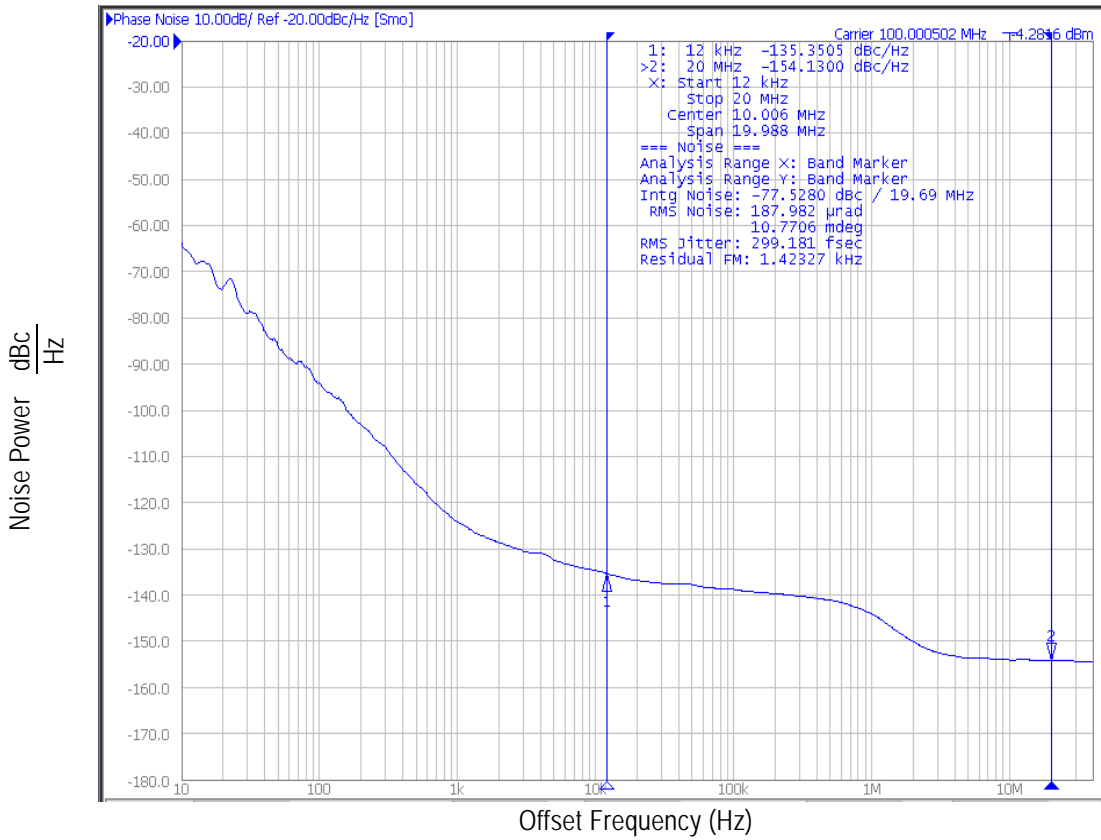

### Typical Phase Noise at 125MHz (LVPECL Output)

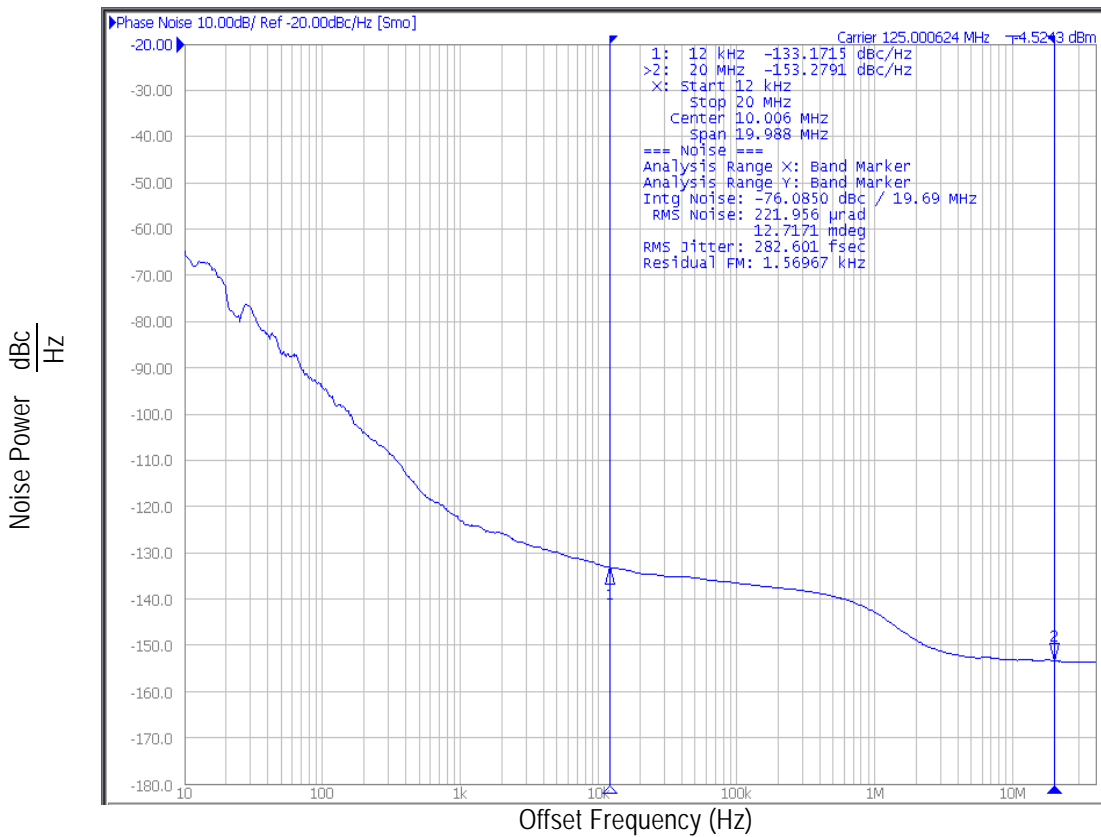

### Typical Phase Noise at 156.25MHz (LVPECL Output)

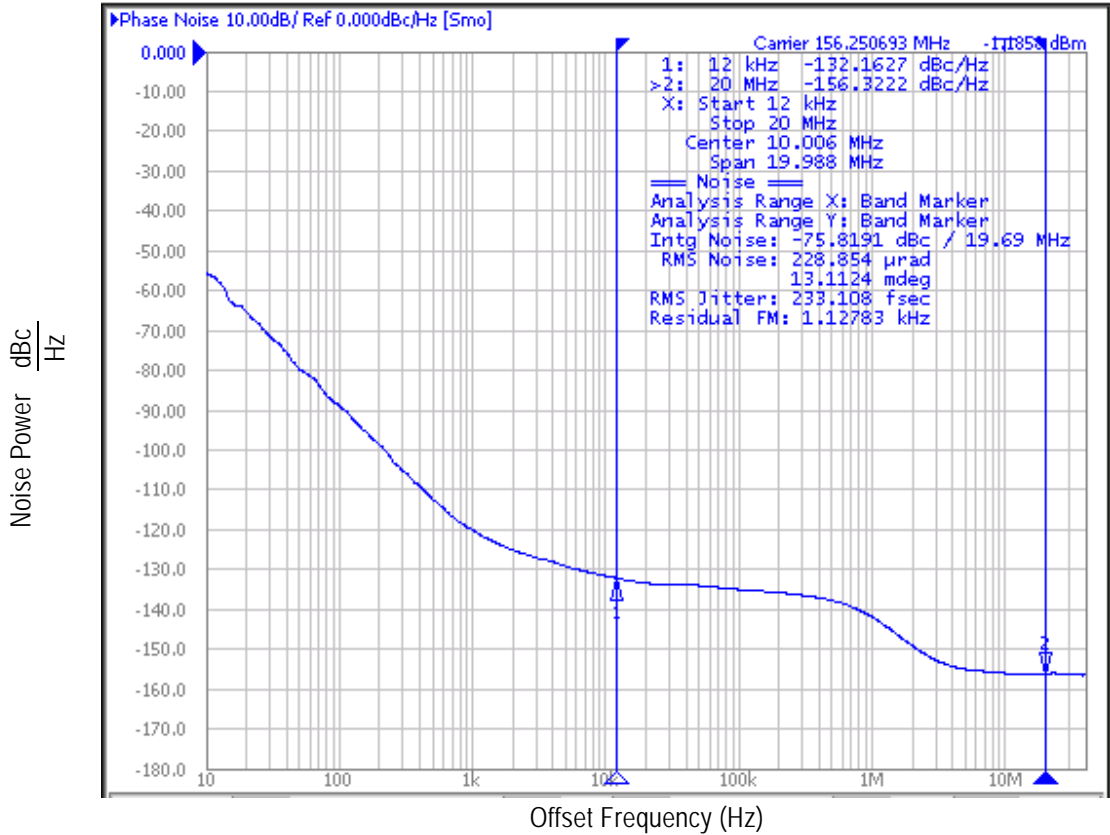

## Parameter Measurement Information

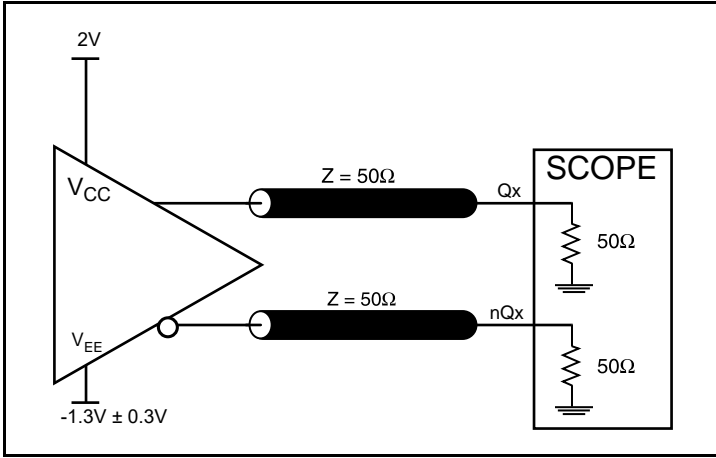

LVPECL Output Load Test Circuit

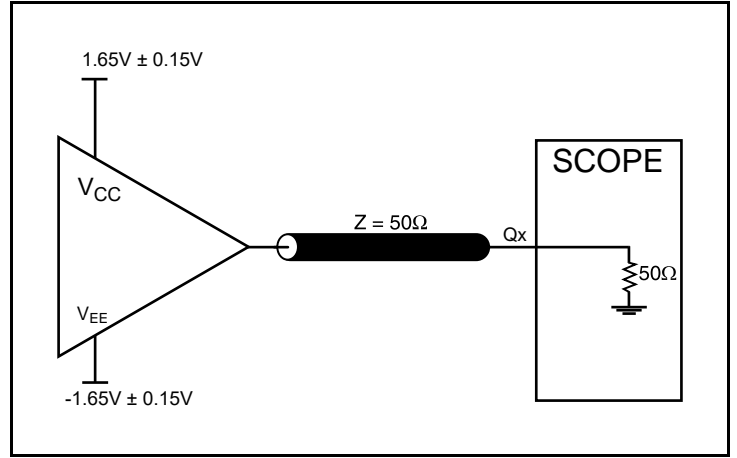

LVCMOS Output Load Test Circuit

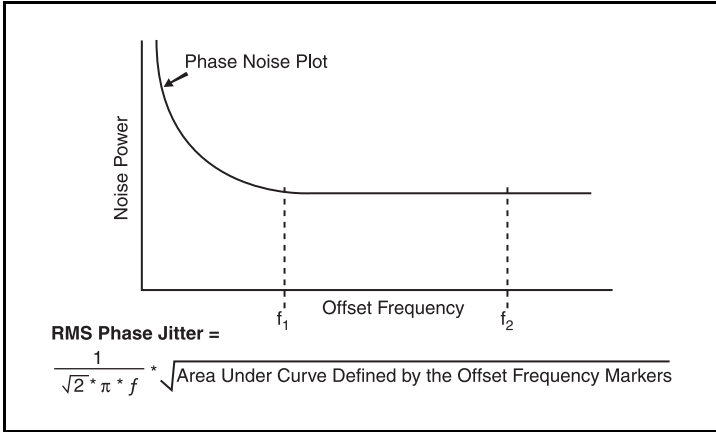

Phase Jitter

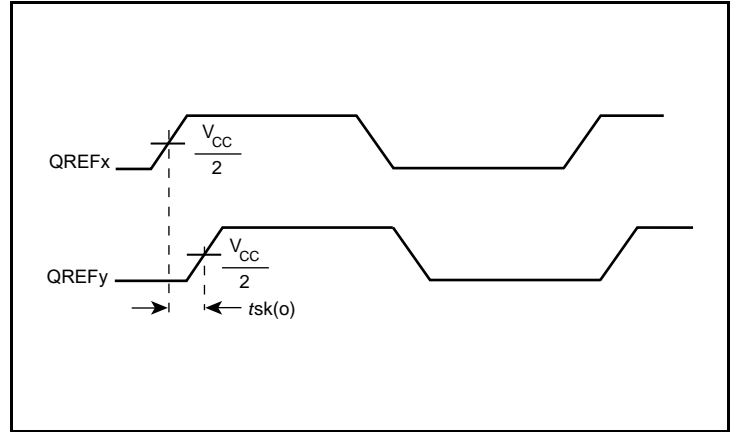

LVCMOS Output Skew

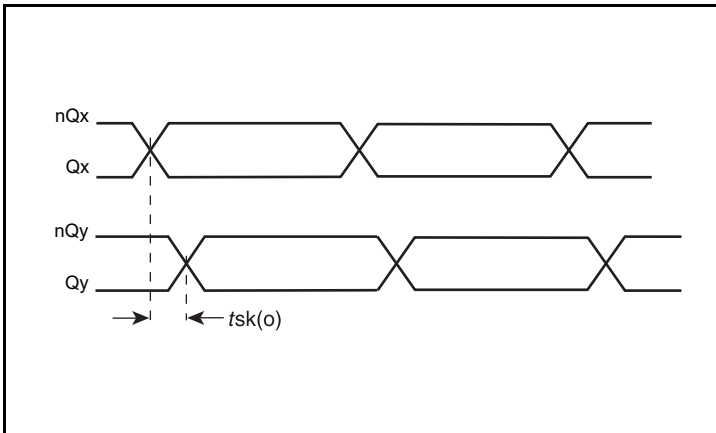

LVPECL Output Skew

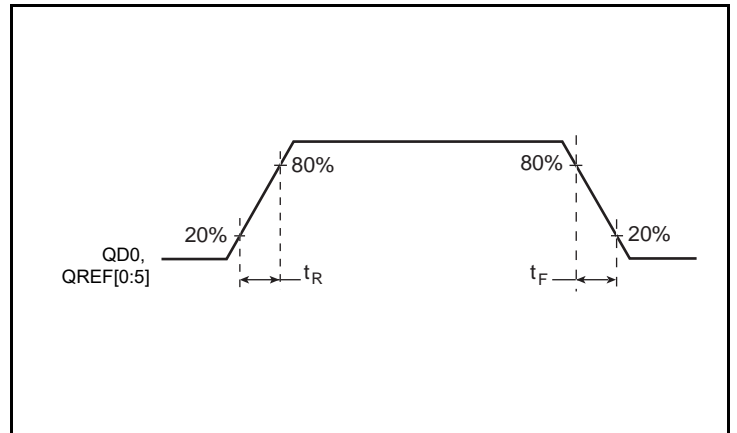

LVCMOS Output Rise/Fall Time

Parameter Measurement Information, continued

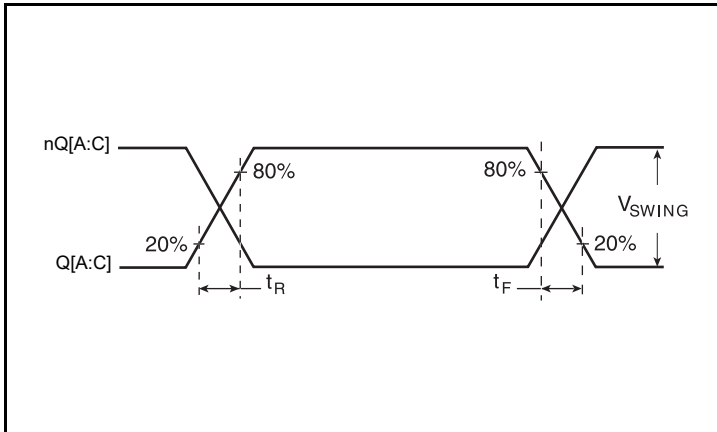

LVPECL Output Rise/Fall Time

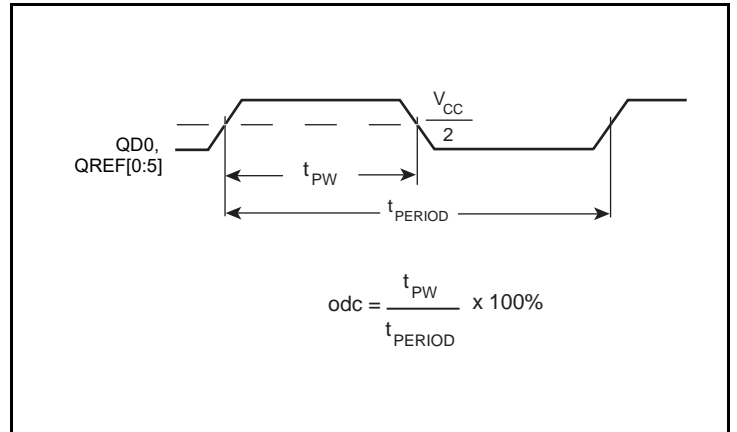

LVCMOS Output Duty Cycle/Pulse Width/Period

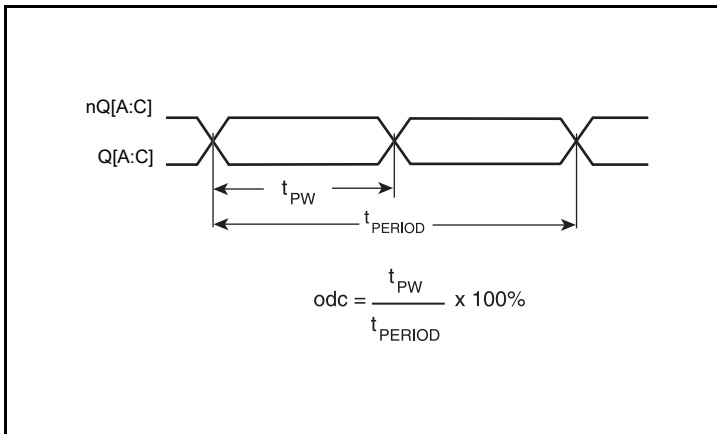

LVPECL Output Duty Cycle/Pulse Width/Period

## Applications Information

### Overdriving the XTAL Interface

The XTAL\_IN input can accept a single-ended LVCMOS signal through an AC coupling capacitor. A general interface diagram is shown in *Figure 1A*. The XTAL\_OUT pin can be left floating. The maximum amplitude of the input signal should not exceed 2V and the input edge rate can be as slow as 10ns. This configuration requires that the output impedance of the driver ( $R_o$ ) plus the series resistance ( $R_s$ ) equals the transmission line impedance. In addition,

matched termination at the crystal input will attenuate the signal in half. This can be done in one of two ways. First,  $R_1$  and  $R_2$  in parallel should equal the transmission line impedance. For most 50Ω applications,  $R_1$  and  $R_2$  can be 100Ω. This can also be accomplished by removing  $R_1$  and making  $R_2$  50Ω. By overdriving the crystal oscillator, the device will be functional, but note, the device performance is guaranteed by using a quartz crystal.

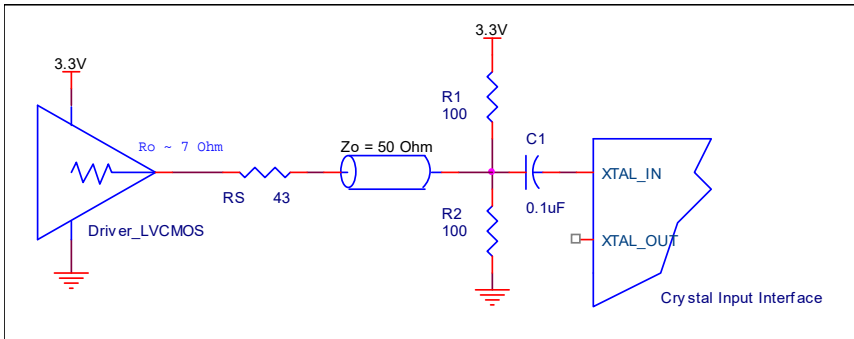

**Figure 1A. General Diagram for LVCMOS Driver to XTAL Input Interface**

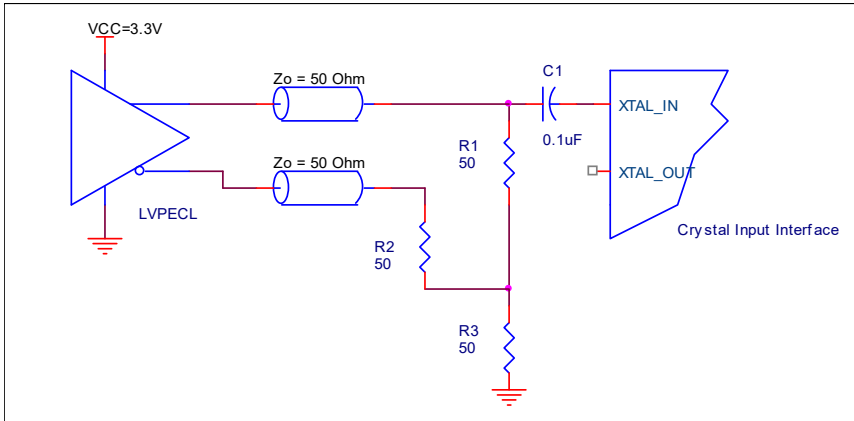

**Figure 1B. General Diagram for LVPECL Driver to XTAL Input Interface**

## VFQFN EPAD Thermal Release Path

In order to maximize both the removal of heat from the package and the electrical performance, a land pattern must be incorporated on the Printed Circuit Board (PCB) within the footprint of the package corresponding to the exposed metal pad or exposed heat slug on the package, as shown in *Figure 2*. The solderable area on the PCB, as defined by the solder mask, should be at least the same size/shape as the exposed pad/slug area on the package to maximize the thermal/electrical performance. Sufficient clearance should be designed on the PCB between the outer edges of the land pattern and the inner edges of pad pattern for the leads to avoid any shorts.

While the land pattern on the PCB provides a means of heat transfer and electrical grounding from the package to the board through a solder joint, thermal vias are necessary to effectively conduct from the surface of the PCB to the ground plane(s). The land pattern must be connected to ground through these vias. The vias act as “heat pipes”. The number of vias (i.e. “heat pipes”) are application specific

and dependent upon the package power dissipation as well as electrical conductivity requirements. Thus, thermal and electrical analysis and/or testing are recommended to determine the minimum number needed. Maximum thermal and electrical performance is achieved when an array of vias is incorporated in the land pattern. It is recommended to use as many vias connected to ground as possible. It is also recommended that the via diameter should be 12 to 13mils (0.30 to 0.33mm) with 1oz copper via barrel plating. This is desirable to avoid any solder wicking inside the via during the soldering process which may result in voids in solder between the exposed pad/slug and the thermal land. Precautions should be taken to eliminate any solder voids between the exposed heat slug and the land pattern. Note: These recommendations are to be used as a guideline only. For further information, please refer to the Application Note on the Surface Mount Assembly of Amkor’s Thermally/Electrically Enhance Leadframe Base Package, Amkor Technology.

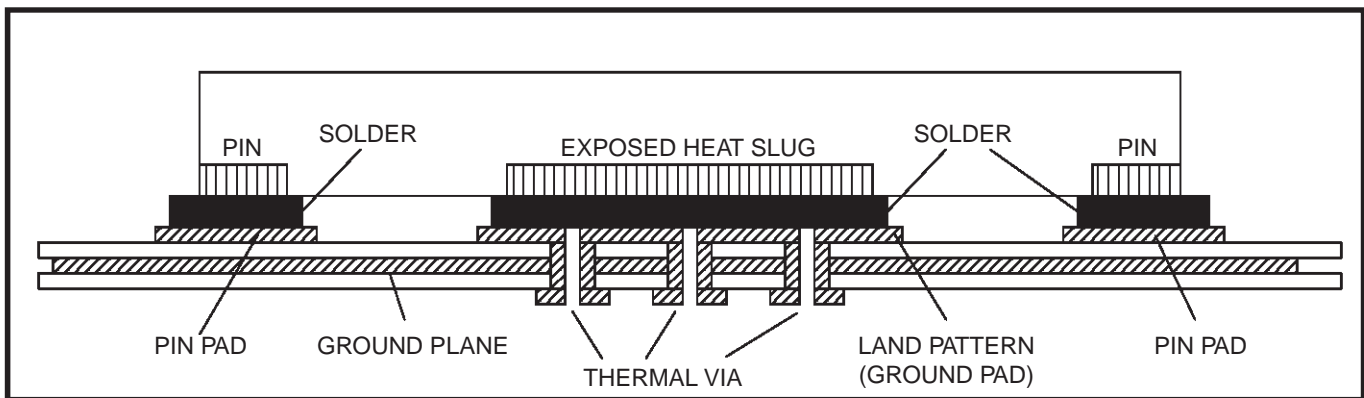

**Figure 2. P.C. Assembly for Exposed Pad Thermal Release Path – Side View (drawing not to scale)**

### Termination for 3.3V LVPECL Outputs

The clock layout topology shown below is a typical termination for LVPECL outputs. The two different layouts mentioned are recommended only as guidelines.

The differential outputs are low impedance follower outputs that generate ECL/LVPECL compatible outputs. Therefore, terminating resistors (DC current path to ground) or current sources must be used for functionality. These outputs are designed to drive 50Ω

transmission lines. Matched impedance techniques should be used to maximize operating frequency and minimize signal distortion.

Figures 3A and 3B show two different layouts which are recommended only as guidelines. Other suitable clock layouts may exist and it would be recommended that the board designers simulate to guarantee compatibility across all printed circuit and clock component process variations.

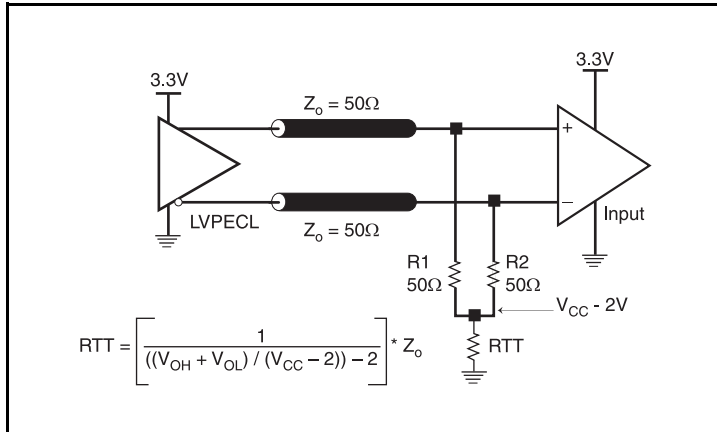

Figure 3A. 3.3V LVPECL Output Termination

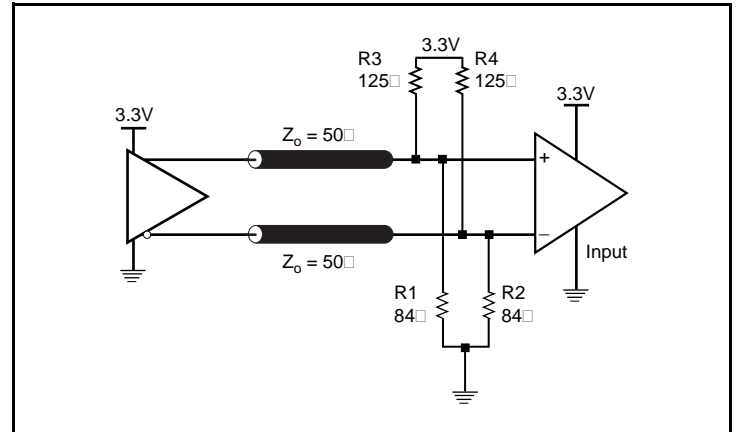

Figure 3B. 3.3V LVPECL Output Termination

### Recommendations for Unused Input and Output Pins

#### Inputs:

##### REFCLK Input

For applications not requiring the use of the reference clock, it can be left floating. Though not required, but for additional protection, a 1kΩ resistor can be tied from the REFCLK to ground.

##### Crystal Inputs

For applications not requiring the use of the crystal oscillator input, both XTAL\_IN and XTAL\_OUT can be left floating. Though not required, but for additional protection, a 1kΩ resistor can be tied from XTAL\_IN to ground.

##### LVC MOS Control Pins

All control pins have internal pull-ups or pull-downs; additional resistance is not required but can be added for additional protection. A 1kΩ resistor can be used.

#### Outputs:

##### LVC MOS Outputs

All unused LVC MOS output can be left floating. There should be no trace attached.

##### LVPECL Outputs:

All unused LVPECL outputs can be left floating. We recommend that there is no trace attached. Both sides of the differential output pair should either be left floating or terminated.

## Application Schematic Example

Figure 4 shows an example of 843N5711 application schematic. In this example, the device is operated at  $V_{CC} = 3.3V$ . An 18pF parallel resonant 25MHz crystal is used. The load capacitance  $C1 = 15pF$  and  $C2 = 15pF$  are recommended for frequency accuracy. Depending on the parasitics of the printed circuit board layout, these values might require slight adjustment to optimize the frequency accuracy. Crystals with other load capacitance specifications can be used. This will require adjusting  $C1$  and  $C2$ . For this device, the crystal load capacitors are required for proper operation.

As with any high speed analog circuitry, the power supply pins are vulnerable to random noise. To achieve optimum jitter performance, power supply isolation is required. In order to achieve the best possible filtering, it is recommended that the placement of the filter components be on the device side of the PCB as close to the power pins as possible. If space is limited, the 0.1uF capacitor in each power pin filter should be placed on the device side. The other

components can be on the opposite side of the PCB.

Power supply filter recommendations are a general guideline to be used for reducing external noise from coupling into the devices. The filter performance is designed for wide range of noise frequency. This low-pass filter starts to attenuate noise at approximately 10kHz. If a specific frequency noise component with high amplitude interference is known, such as switching power supplies frequencies, it is recommended that component values be adjusted and if required, additional filtering be added. Additionally general design practice for power plane voltage stability suggests adding bulk capacitances in the general area of all devices.

The schematic example focuses on functional connections and is not configuration specific. Refer to the pin description and functional tables in the datasheet to ensure the logic control inputs are properly set.

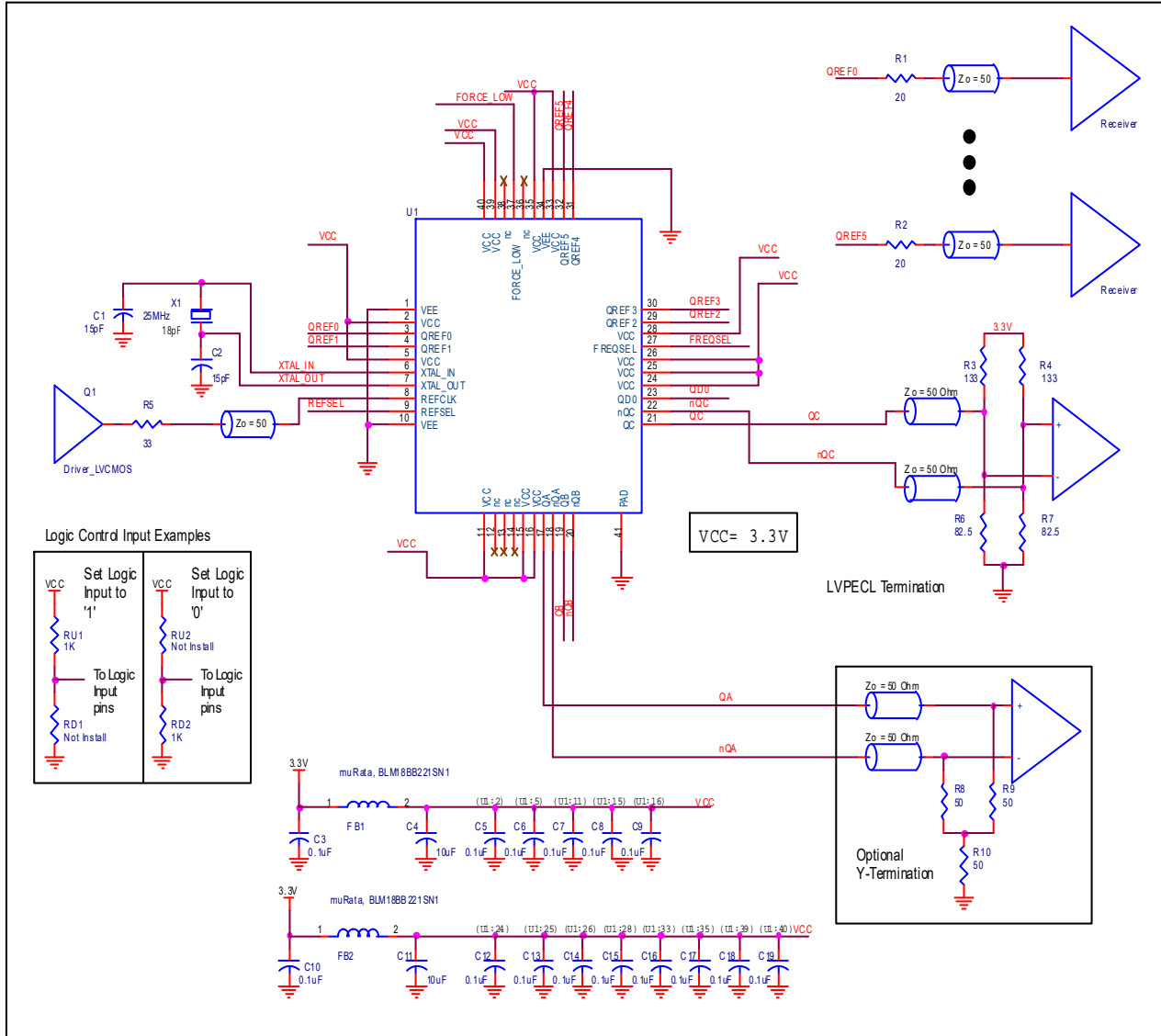

Figure 4. 843N571I Application Schematic

## Power Considerations

This section provides information on power dissipation and junction temperature for the 843N5711. Equations and example calculations are also provided.

### 1. Power Dissipation.

The total power dissipation for the 843N5711 is the sum of the core power plus the power dissipated due to loading. The following is the power dissipation for  $V_{CC} = 3.6V$ , which gives worst case results.

NOTE: Please refer to Section 3 for details on calculating power dissipated due to loading.

#### Core and LVPECL Output Power Dissipation

- Power (core)<sub>MAX</sub> =  $V_{CC\_MAX} * I_{EE\_MAX} = 3.6V * 250mA = 900mW$
- Power (outputs)<sub>MAX</sub> = **32mW/Loaded Output pair**  
If all outputs are loaded, the total power is  $3 * 32mW = 96mW$

#### Dynamic Power Dissipation at 33.3333MHz and 25MHz

$$\begin{aligned} \text{Power (33.33MHz)} &= C_{PD} * \text{Frequency} * (V_{CC})^2 * \# \text{ of outputs} = 6pF * 33.3333MHz * (3.6V)^2 * 1 = \mathbf{2.592mW} \\ \text{Power (25MHz)} &= C_{PD} * \text{Frequency} * (V_{CC})^2 * \# \text{ of outputs} = 6pF * 25MHz * (3.6V)^2 * 6 = \mathbf{11.664mW} \end{aligned}$$

#### Total Power Dissipation

- Total Power**  
= Power (Core) + Power (Output) + Dynamic Power (33.3333MHz) + Dynamic Power (25MHz)  
=  $900mW + 96mW + 2.592mW + 11.66mW$   
= **1010.252mW**

### 2. Junction Temperature.

Junction temperature,  $T_j$ , is the temperature at the junction of the bond wire and bond pad, and directly affects the reliability of the device. The maximum recommended junction temperature is 125°C. Limiting the internal transistor junction temperature,  $T_j$ , to 125°C ensures that the bond wire and bond pad temperature remains below 125°C.

The equation for  $T_j$  is as follows:  $T_j = \theta_{JA} * Pd\_total + T_A$

$T_j$  = Junction Temperature

$\theta_{JA}$  = Junction-to-Ambient Thermal Resistance

$Pd\_total$  = Total Device Power Dissipation (example calculation is in section 1 above)

$T_A$  = Ambient Temperature

In order to calculate junction temperature, the appropriate junction-to-ambient thermal resistance  $\theta_{JA}$  must be used. Assuming no air flow and a multi-layer board, the appropriate value is 37.7°C/W per Table 7 below.

Therefore,  $T_j$  for an ambient temperature of 85°C with all outputs switching is:

$$85^\circ C + 1.010W * 37.7^\circ C/W = 123.1^\circ C. \text{ This is below the limit of } 125^\circ C.$$

This calculation is only an example.  $T_j$  will obviously vary depending on the number of loaded outputs, supply voltage, air flow and the type of board (multi-layer).

**Table 7. Thermal Resistance  $\theta_{JA}$  for 40 Lead VFQFN Forced Convection**

$\theta_{JA}$ by Velocity			
Meters per Second	0	1	2.5
Multi-Layer PCB, JEDEC Standard Test Boards	37.7°C/W	31.6°C/W	28.8°C/W

### 3. Calculations and Equations.

The purpose of this section is to calculate the power dissipation for the LVPECL output pairs.

LVPECL output driver circuit and termination are shown in *Figure 5*.

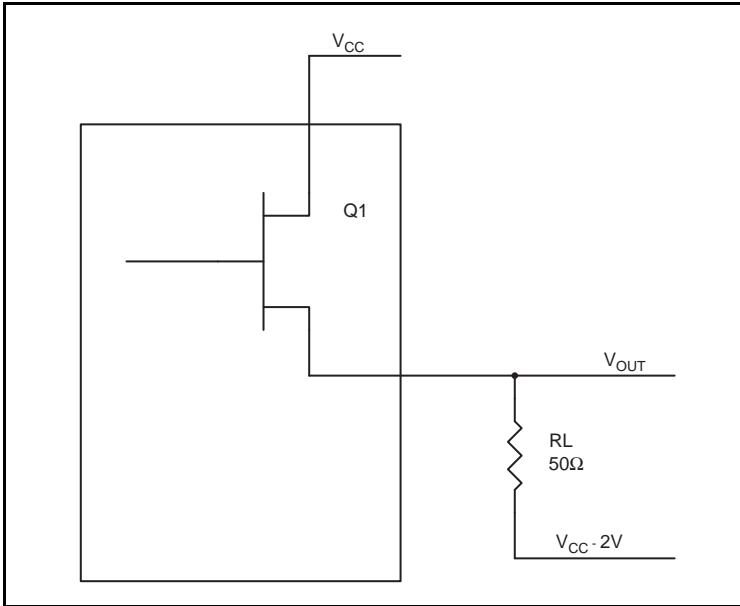

**Figure 5. LVPECL Driver Circuit and Termination**

To calculate power dissipation due to loading, use the following equations which assume a 50Ω load, and a termination voltage of V<sub>CC</sub> - 2V.

- For logic high, V<sub>OUT</sub> = V<sub>OH\_MAX</sub> = V<sub>CC\_MAX</sub> - 0.8V  
(V<sub>CC\_MAX</sub> - V<sub>OH\_MAX</sub>) = 0.8V
- For logic low, V<sub>OUT</sub> = V<sub>OL\_MAX</sub> = V<sub>CC\_MAX</sub> - 1.6V  
(V<sub>CC\_MAX</sub> - V<sub>OL\_MAX</sub>) = 1.6V
- 

Pd<sub>H</sub> is power dissipation when the output drives high.

Pd<sub>L</sub> is the power dissipation when the output drives low.

$$Pd_H = [(V_{OH\_MAX} - (V_{CC\_MAX} - 2V))/R_L] * (V_{CC\_MAX} - V_{OH\_MAX}) = [(2V - (V_{CC\_MAX} - V_{OH\_MAX}))/R_L] * (V_{CC\_MAX} - V_{OH\_MAX}) = [(2V - 0.8V)/50\Omega] * 0.8V = \mathbf{19.2mW}$$

$$Pd_L = [(V_{OL\_MAX} - (V_{CC\_MAX} - 2V))/R_L] * (V_{CC\_MAX} - V_{OL\_MAX}) = [(2V - (V_{CC\_MAX} - V_{OL\_MAX}))/R_L] * (V_{CC\_MAX} - V_{OL\_MAX}) = [(2V - 1.6V)/50\Omega] * 1.6V = \mathbf{12.8mW}$$

$$\text{Total Power Dissipation per output pair} = Pd_H + Pd_L = \mathbf{32mW}$$

## Reliability Information

**Table 8.  $\theta_{JA}$  vs. Air Flow Table for a 40 Lead VFQFN**

$\theta_{JA}$ vs. Air Flow			
Meters per Second	0	1	2.5
Multi-Layer PCB, JEDEC Standard Test Boards	37.7°C/W	31.6°C/W	28.8°C/W

## Transistor Count

The transistor count for 843N5711 is: 22,466

## Package Outline Drawings

The package outline drawings are appended at the end of this document and are accessible from the link below. The package information is the most current data available.

[www.idt.com/document/psc/nlnlg-40-package-outline-60-x-60-mm-body-epad-290-x-290-mm-qfn](http://www.idt.com/document/psc/nlnlg-40-package-outline-60-x-60-mm-body-epad-290-x-290-mm-qfn)

## Ordering Information

**Table 10. Ordering Information**

Part/Order Number	Marking	Package	Shipping Packaging	Temperature
843N571BKILF	ICS43N571BIL	"Lead-Free" 40 Lead VFQFN	Tray	-40°C to 85°C
843N571BKILFT	ICS43N571BIL	"Lead-Free" 40 Lead VFQFN	Tape & Reel	-40°C to 85°C

## Revision History

Revision Date	Description of Change
November 29, 2018	Updated description of Absolute Maximum Ratings; also added $T_{J,MAX}$ to the table Added Recommended Operating Conditions Updated Package Outline Drawings; however, no technical changes
April 20, 2016	Removed ICS from the part number where needed. Updated data sheet header and footer.
October 4, 2013	PCN #N1302-03_RTB expired.
PCN Expiration Date August 16, 2013	PCN Expiration Period extended to 8/16/2013. Front Page, updated PCN Notification Period. Corrected block diagram. Pin Description Table - showed rest of QREFx pin names. Absolute Maximum Ratings - XTAL_IN input rating, changed from $V_{CC}$ to 2V. LVCMOS DC Characteristics Table - add units to $V_{IH}$ . AC Characteristics Table - changed $f_{OUT}$ min. spec from 25MHz to 100MHz. AC Tables - corrected TA temperature from -25°C to 25°C. Power Considerations - added missing Power Output to Total Power Calculation. Revision History Sheet - changed Date column to the extended PCN date.
May 20, 2013	$f_{OUT}$ Minimum = 100MHz
April 3, 2013	PCN N1302-03 Notification Period Expires 5/28/2013 Part/Order Number: 843N571BKILF, 843N571BKILFT Marking: ICS43N571BIL



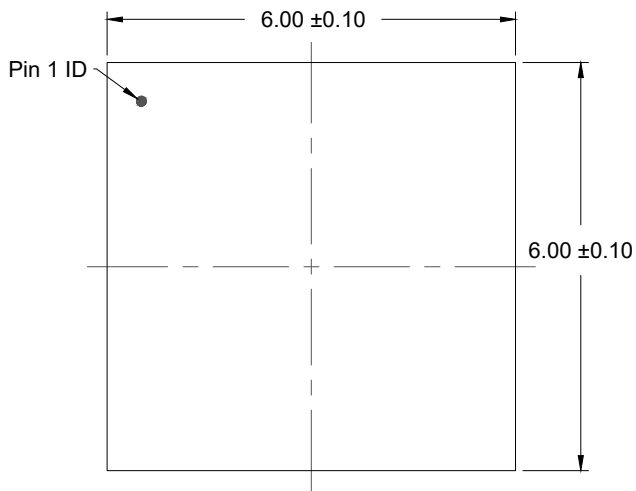

TOP VIEW

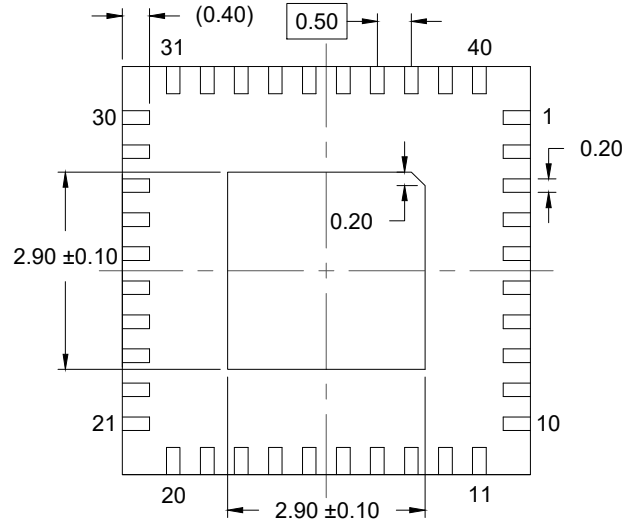

BOTTOM VIEW

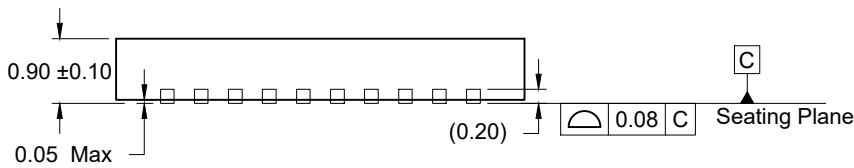

SIDE VIEW

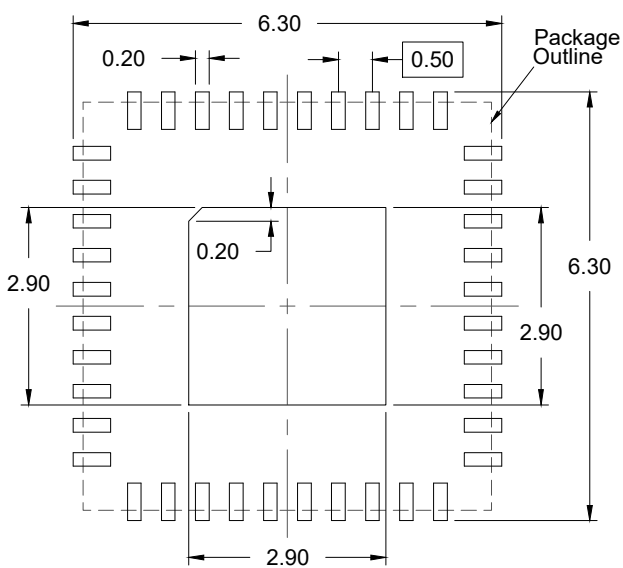

RECOMMENDED LAND PATTERN  
(PCB Top View, NSMD Design)

NOTES:

1. JEDEC compatible.
2. All dimensions are in mm and angles are in degrees.
3. Use  $\pm 0.05$  mm for the non-toleranced dimensions.
4. Numbers in ( ) are for references only.

## IMPORTANT NOTICE AND DISCLAIMER

RENESAS ELECTRONICS CORPORATION AND ITS SUBSIDIARIES (“RENESAS”) PROVIDES TECHNICAL SPECIFICATIONS AND RELIABILITY DATA (INCLUDING DATASHEETS), DESIGN RESOURCES (INCLUDING REFERENCE DESIGNS), APPLICATION OR OTHER DESIGN ADVICE, WEB TOOLS, SAFETY INFORMATION, AND OTHER RESOURCES “AS IS” AND WITH ALL FAULTS, AND DISCLAIMS ALL WARRANTIES, EXPRESS OR IMPLIED, INCLUDING, WITHOUT LIMITATION, ANY IMPLIED WARRANTIES OF MERCHANTABILITY, FITNESS FOR A PARTICULAR PURPOSE, OR NON-INFRINGEMENT OF THIRD-PARTY INTELLECTUAL PROPERTY RIGHTS.

These resources are intended for developers who are designing with Renesas products. You are solely responsible for (1) selecting the appropriate products for your application, (2) designing, validating, and testing your application, and (3) ensuring your application meets applicable standards, and any other safety, security, or other requirements. These resources are subject to change without notice. Renesas grants you permission to use these resources only to develop an application that uses Renesas products. Other reproduction or use of these resources is strictly prohibited. No license is granted to any other Renesas intellectual property or to any third-party intellectual property. Renesas disclaims responsibility for, and you will fully indemnify Renesas and its representatives against, any claims, damages, costs, losses, or liabilities arising from your use of these resources. Renesas' products are provided only subject to Renesas' Terms and Conditions of Sale or other applicable terms agreed to in writing. No use of any Renesas resources expands or otherwise alters any applicable warranties or warranty disclaimers for these products.

(Disclaimer Rev.1.01 Jan 2024)

### Corporate Headquarters

TOYOSU FORESIA, 3-2-24 Toyosu,  
Koto-ku, Tokyo 135-0061, Japan  
[www.renesas.com](http://www.renesas.com)

### Trademarks

Renesas and the Renesas logo are trademarks of Renesas Electronics Corporation. All trademarks and registered trademarks are the property of their respective owners.

### Contact Information

For further information on a product, technology, the most up-to-date version of a document, or your nearest sales office, please visit [www.renesas.com/contact-us/](http://www.renesas.com/contact-us/).

## Looking for pricing, stock, or lifecycle information?

Click below to explore more details on WIN SOURCE:

- ⊖ [View 843N571BKILF on WIN SOURCE](#)
- ⊖ [Renesas Electronics America](#) Information

## Optimize Your Supply Chain with WIN SOURCE Solutions

- ✓ Global Sourcing Solution
- ✓ Obsolete Management
- ✓ Cost Control Management
- ✓ Shortage Management
- ✓ Alternative Solution
- ✓ Excess Inventory Management