



**THE DATASHEET OF
8SLVP2102ANLGI/W**



Description

The 8SLVP2102 is a high-performance differential LVPECL fanout buffer. The device is designed for the fanout of high-frequency, very low additive phase-noise clock and data signals. The 8SLVP2102 is characterized to operate from a 3.3V or 2.5V power supply.

Guaranteed output-to-output and part-to-part skew characteristics make the 8SLVP2102 ideal for those clock distribution applications demanding well-defined performance and repeatability.

Two selectable differential inputs and four low skew outputs are available. The integrated bias voltage reference enables easy interfacing of single-ended signals to the device inputs. The device is optimized for low power consumption and low additive phase noise.

Features

- Two low skew, low additive jitter LVPECL output pairs
- Two selectable, differential clock input pairs
- Differential pairs can accept the following differential input levels: LVDS, LVPECL, CML
- Maximum input clock frequency: 2GHz
- Output skew: 5ps (typical)
- Propagation delay: 225ps (maximum)
- Low additive phase jitter, RMS, $f_{REF} = 156.25\text{MHz}$, $V_{PP} = 1\text{V}$, 12kHz – 20MHz: 36fs (maximum)
- Full 3.3V and 2.5V supply voltage
- Maximum device current consumption (I_{EE}): 56mA (maximum)
- Available in lead-free (RoHS 6), 16-Lead VFQFPN package
- -40°C to 85°C ambient operating temperature
- Supports case temperature $\leq 105^\circ\text{C}$ operations
- Accepts single-ended LVCMOS levels. See Applications section
- Differential PCLKA, nPCLKA and PCLKB, nPCLKB pairs can also accept single-ended LVCMOS levels. See Applications section Wiring the Differential Input Levels to Accept Single-ended Levels (Figure 1A and Figure 1B)

Pin Assignment

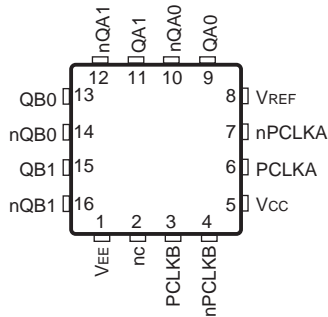

8SLVP2102
16-Lead VFQFPN
3.0mm x 3.0mm x 0.925mm package body
NL Package
Top View

Block Diagram

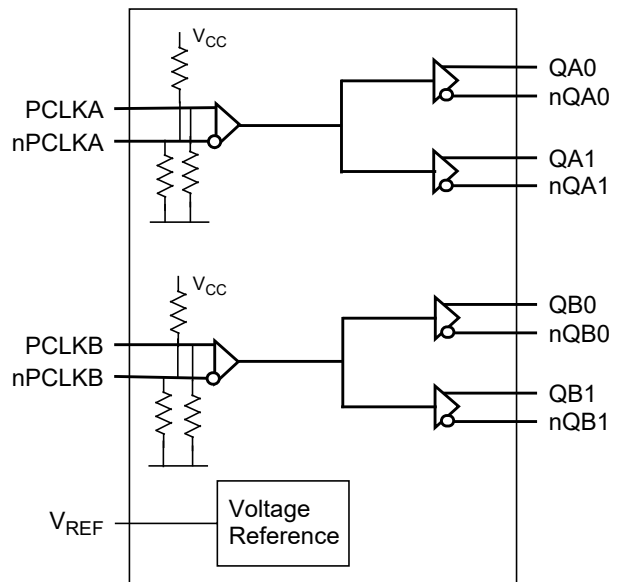

Pin Descriptions and Characteristics

Table 1. Pin Descriptions

Number	Name	Type		Description
1	V _{EE}	Power		Negative supply pin.
2	nc	Unused		Do not connect.
3	PCLKB	Input	Pulldown	Non-inverting differential LVPECL clock/data input.
4	nPCLKB	Input	Pullup/ Pulldown	Inverting differential LVPECL clock/data input. V _{CC} /2 default when left floating.
5	V _{CC}	Power		Power supply pins.
6	PCLKA	Input	Pulldown	Non-inverting differential LVPECL clock/data input.
7	nPCLKA	Input	Pullup/ Pulldown	Inverting differential LVPECL clock/data input. V _{CC} /2 default when left floating.
8	V _{REF}	Output		Bias voltage reference for the PCLK, nPCLK inputs.
9, 10	QA0, nQA0	Output		Differential output pair A0. LVPECL interface levels.
11, 12	QA1, nQA1	Output		Differential output pair A1. LVPECL interface levels.
13, 14	QB0, nQB0	Output		Differential output pair B0. LVPECL interface levels.
15, 16	QB1, nQB1	Output		Differential output pair B1. LVPECL interface levels.

NOTE: *Pulldown* and *Pullup* refers to an internal input resistors. See Table 2, *Pin Characteristics*, for typical values.

Table 2. Pin Characteristics

Symbol	Parameter	Test Conditions	Minimum	Typical	Maximum	Units
C _{IN}	Input Capacitance			2		pF
R _{PULLDOWN}	Input Pulldown Resistor			51		kΩ
R _{PULLUP}	Input Pullup Resistor			51		kΩ

Absolute Maximum Ratings

NOTE: Stresses beyond those listed under *Absolute Maximum Ratings* may cause permanent damage to the device. These ratings are stress specifications only. Functional operation of the product at these conditions or any conditions beyond those listed in the *DC Characteristics* or *AC Characteristics* is not implied. Exposure to absolute maximum rating conditions for extended periods may affect product reliability.

Item	Rating
Supply Voltage, V_{CC}	3.63V
Inputs, V_I	-0.5V to $V_{CC} + 0.5V$
Outputs, I_O Continuous Current Surge Current	50mA 100mA
Input Sink/Source, I_{REF}	$\pm 2mA$
Maximum Junction Temperature, $T_{J,MAX}$	125°C
Storage Temperature, T_{STG}	-65°C to 150°C
ESD - Human Body Model (NOTE 1)	2000V
ESD - Charged Device Model (NOTE 1)	1500V

NOTE 1: According to JEDEC/JESD 22-A114/22-C101.

DC Electrical Characteristics

Table 3A. Power Supply DC Characteristics, $V_{CC} = 3.3V \pm 5\%$, $V_{EE} = 0V$, $T_A = -40^\circ C$ to $85^\circ C$

Symbol	Parameter	Test Conditions	Minimum	Typical	Maximum	Units
V_{CC}	Power Supply Voltage		3.135	3.3	3.465	V
I_{EE}	Power Supply Current				56	mA
I_{CC}	Power Supply Current	QA[0:1] and QB[0:1] terminated $50W \pm 1\%$ to $V_{CC} - 2V$			180	mA

Table 3B. Power Supply DC Characteristics, $V_{CC} = 2.5V \pm 5\%$, $V_{EE} = 0V$, $T_A = -40^\circ C$ to $85^\circ C$

Symbol	Parameter	Test Conditions	Minimum	Typical	Maximum	Units
V_{CC}	Power Supply Voltage		2.375	2.5	2.625	V
I_{EE}	Power Supply Current				50	mA
I_{CC}	Power Supply Current	QA[0:1] and QB[0:1] terminated $50W \pm 1\%$ to $V_{CC} - 2V$			180	mA

Table 3C. LVPECL DC Characteristics, $V_{CC} = 3.3V \pm 5\%$, $V_{EE} = 0V$, $T_A = -40^{\circ}C$ to $85^{\circ}C$

Symbol	Parameter		Test Conditions	Minimum	Typical	Maximum	Units
I_{IH}	Input High Current	PCLKA, nPCLKA; PCLKB, nPCLKB	$V_{CC} = V_{IN} = 3.465V$			150	μA
I_{IL}	Input Low Current	PCLKA, PCLKB	$V_{CC} = 3.465V, V_{IN} = 0V$	-10			μA
		nPCLKA, nPCLKB	$V_{CC} = 3.465V, V_{IN} = 0V$	-150			μA
V_{REF}	Reference Voltage for Input Bias		$I_{REF} = 2mA$	$V_{CC} - 1.6$	$V_{CC} - 1.3$	$V_{CC} - 1.1$	V
V_{OH}	Output High Voltage; NOTE 1			$V_{CC} - 1.1$	$V_{CC} - 0.9$	$V_{CC} - 0.8$	V
V_{OL}	Output Low Voltage; NOTE 1			$V_{CC} - 2.0$	$V_{CC} - 1.5$	$V_{CC} - 1.4$	V

NOTE 1: Outputs terminated with 50Ω to $V_{CC} - 2V$.

Table 3D. LVPECL DC Characteristics, $V_{CC} = 2.5V \pm 5\%$, $V_{EE} = 0V$, $T_A = -40^{\circ}C$ to $85^{\circ}C$

Symbol	Parameter		Test Conditions	Minimum	Typical	Maximum	Units
I_{IH}	Input High Current	PCLKA, nPCLKA; PCLKB, nPCLKB	$V_{CC} = V_{IN} = 2.625V$			150	μA
I_{IL}	Input Low Current	PCLKA, PCLKB	$V_{CC} = 2.625V, V_{IN} = 0V$	-10			μA
		nPCLKA, nPCLKB	$V_{CC} = 2.625V, V_{IN} = 0V$	-150			μA
V_{REF}	Reference Voltage for Input Bias		$I_{REF} = 2mA$	$V_{CC} - 1.6$	$V_{CC} - 1.3$	$V_{CC} - 1.1$	V
V_{OH}	Output High Voltage; NOTE 1			$V_{CC} - 1.1$	$V_{CC} - 0.9$	$V_{CC} - 0.8$	V
V_{OL}	Output Low Voltage; NOTE 1			$V_{CC} - 2.0$	$V_{CC} - 1.5$	$V_{CC} - 1.4$	V

NOTE 1: Outputs terminated with 50Ω to $V_{CC} - 2V$.

AC Electrical Characteristics

Table 4A. AC Electrical Characteristics, $V_{CC} = 3.3V \pm 5\%$ or $2.5V \pm 5\%$, $V_{EE} = 0V$, $T_A = -40^\circ C$ to $85^\circ C$

Symbol	Parameter	Test Conditions	Minimum	Typical	Maximum	Units
f_{REF}	Input Frequency PCLKA, nPCLKA; PCLKB, nPCLKB				2	GHz
$\Delta V/\Delta t$	Input Edge Rate PCLKA, nPCLKA; PCLKB, nPCLKB		1.5			V/ns
t_{PD}	Propagation Delay; NOTE 1	PCLKA, nPCLKA to any QAx, nQAx or PCLKB, nPCLKB to any QBx, nQBx for $V_{PP} = 0.1V$ or $0.3V$	40	135	225	ps
$t_{sk(o)}$	Output Skew; NOTE 2, 3			5	15	ps
$t_{sk(b)}$	Bank Skew; NOTE 3, 4			3	10	ps
$t_{sk(p)}$	Pulse Skew	$f_{REF} = 100MHz$		10	25	ps
$t_{sk(pp)}$	Part-to-Part Skew; NOTE 3, 5			100	175	ps
$t_{JIT, SP}$	Spurious Suppression, Coupling from QA0 to QB0	$f_{QB0} = 500MHz$, $V_{PP(PCLKB)} = 0.15V$, $V_{CMR(PCLKB)} = 1V$ and $f_{QA0} = 62.5MHz$, $V_{PP(PCLKA)} = 1V$, $V_{CMR(PCLKA)} = 1V$		-58		dB
		$f_{QB0} = 500MHz$, $V_{PP(PCLKB)} = 0.15V$, $V_{CMR(PCLKB)} = 1V$ and $f_{QA0} = 15.625MHz$, $V_{PP(PCLKA)} = 1V$, $V_{CMR(PCLKA)} = 1V$		-70		dB
Channel_ISOL	Channel Isolation	$f_{REF} = 122.88MHz$		65		dB
t_R / t_F	Output Rise/ Fall Time	20% to 80%	25	90	140	ps
V_{PP}	Peak-to-Peak Input Voltage; NOTE 6, 8	$f_{REF} < 1.5GHz$	0.1		1.5	V
		$f_{REF} > 1.5GHz$	0.2		1.5	V
V_{CMR}	Common Mode Input Voltage; NOTE 6, 7, 8		1.0		$V_{CC} - 0.6$	V
$V_{O(pp)}$	Output Voltage Swing, Peak-to-Peak	$V_{CC} = 3.3V$, $f_{REF} \leq 2GHz$	0.40	0.60	1.0	V
		$V_{CC} = 2.5V$, $f_{REF} \leq 2GHz$	0.35	0.55	1.0	V
V_{DIFF_OUT}	Differential Output Voltage Swing, Peak-to-Peak	$V_{CC} = 3.3V$, $f_{REF} \leq 2GHz$	0.80	1.2	20	V
		$V_{CC} = 2.5V$, $f_{REF} \leq 2GHz$	0.70	1.1	2.0	V

NOTE: Electrical parameters are guaranteed over the specified ambient operating temperature range, which is established when the device is mounted in a test socket with maintained transverse airflow greater than 500 lfm. The device will meet specifications after thermal equilibrium has been reached under these conditions.

NOTE 1: Measured from the differential input crossing point to the differential output crosspoint.

NOTE 2: Defined as skew between outputs at the same supply voltage and with equal load conditions. Measured at the differential crosspoints.

NOTE 3: This parameter is defined in accordance with JEDEC Standard 65.

NOTE 4: Defined as skew within a bank with equal load conditions. Measured at the differential crosspoints.

NOTE 5: Defined as skew between outputs on different devices operating at the same supply voltage, same frequency, same temperature and with equal load conditions. Using the same type of inputs on each device, the outputs are measured at the differential crosspoints.

NOTE 6: V_{IL} should not be less than $-0.3V$. V_{IH} should not be higher than V_{CC} .

NOTE 7: Common mode input voltage is defined at the crosspoint.

NOTE 8: For single-ended LVCMOS input applications, please refer to the Applications Information, Wiring the Differential Input to accept single-ended levels, Figures 1A and 1B.

Table 4B. AC Additive Phase Jitter Electrical Characteristics, $V_{CC} = 3.3V \pm 5\%$, $V_{EE} = 0V$, $T_A = -40^\circ C$ to $85^\circ C$

Symbol	Parameter	Test Conditions	Minimum	Typical	Maximum	Units
t_{JIT}	Buffer Additive Phase Jitter, RMS; refer to Additive Phase Jitter Section	$f_{REF} = 122.88\text{MHz}$ Square Wave, $V_{PP} = 1V$, Integration Range: 1kHz – 40MHz		79	95	fs
		$f_{REF} = 122.88\text{MHz}$ Square Wave, $V_{PP} = 1V$, Integration Range: 10kHz – 20MHz		45	61	fs
		$f_{REF} = 122.88\text{MHz}$ Square Wave, $V_{PP} = 1V$, Integration Range: 12kHz – 20MHz		45	61	fs
		$f_{REF} = 156.25\text{MHz}$ Square Wave, $V_{PP} = 1V$, Integration Range: 1kHz – 40MHz		43	49	fs
		$f_{REF} = 156.25\text{MHz}$ Square Wave, $V_{PP} = 1V$, Integration Range: 10kHz – 20MHz		32	36	fs
		$f_{REF} = 156.25\text{MHz}$ Square Wave, $V_{PP} = 1V$, Integration Range: 12kHz – 20MHz		32	36	fs
		$f_{REF} = 156.25\text{MHz}$ Square Wave, $V_{PP} = 0.5V$, Integration Range: 1kHz – 40MHz		43	50	fs
		$f_{REF} = 156.25\text{MHz}$ Square Wave, $V_{PP} = 0.5V$, Integration Range: 10kHz – 20MHz		31	35	fs
		$f_{REF} = 156.25\text{MHz}$ Square Wave, $V_{PP} = 0.5V$, Integration Range: 12kHz – 20MHz		31	35	fs

NOTE: Electrical parameters are guaranteed over the specified ambient operating temperature range, which is established when the device is mounted in a test socket with maintained transverse airflow greater than 500 lfpm. The device will meet specifications after thermal equilibrium has been reached under these conditions.

Table 4C. AC Additive Phase Jitter Electrical Characteristics, $V_{CC} = 2.5V \pm 5\%$, $V_{EE} = 0V$, $T_A = -40^\circ C$ to $85^\circ C$

Symbol	Parameter	Test Conditions	Minimum	Typical	Maximum	Units
t_{JIT}	Buffer Additive Phase Jitter, RMS; refer to Additive Phase Jitter Section	$f_{REF} = 122.88\text{MHz}$ Square Wave, $V_{PP} = 1V$, Integration Range: 1kHz – 40MHz		82	95	fs
		$f_{REF} = 122.88\text{MHz}$ Square Wave, $V_{PP} = 1V$, Integration Range: 10kHz – 20MHz		50	66	fs
		$f_{REF} = 122.88\text{MHz}$ Square Wave, $V_{PP} = 1V$, Integration Range: 12kHz – 20MHz		50	66	fs
		$f_{REF} = 156.25\text{MHz}$ Square Wave, $V_{PP} = 1V$, Integration Range: 1kHz – 40MHz		51	68	fs
		$f_{REF} = 156.25\text{MHz}$ Square Wave, $V_{PP} = 1V$, Integration Range: 10kHz – 20MHz		37	48	fs
		$f_{REF} = 156.25\text{MHz}$ Square Wave, $V_{PP} = 1V$, Integration Range: 12kHz – 20MHz		37	48	fs
		$f_{REF} = 156.25\text{MHz}$ Square Wave, $V_{PP} = 0.5V$, Integration Range: 1kHz – 40MHz		48	54	fs
		$f_{REF} = 156.25\text{MHz}$ Square Wave, $V_{PP} = 0.5V$, Integration Range: 10kHz – 20MHz		34	38	fs
		$f_{REF} = 156.25\text{MHz}$ Square Wave, $V_{PP} = 0.5V$, Integration Range: 12kHz – 20MHz		34	38	fs

NOTE: Electrical parameters are guaranteed over the specified ambient operating temperature range, which is established when the device is mounted in a test socket with maintained transverse airflow greater than 500 lfpm. The device will meet specifications after thermal equilibrium has been reached under these conditions.

Additive Phase Jitter

The spectral purity in a band at a specific offset from the fundamental compared to the power of the fundamental is called the **dBc Phase Noise**. This value is normally expressed using a Phase noise plot and is most often the specified plot in many applications. Phase noise is defined as the ratio of the noise power present in a 1Hz band at a specified offset from the fundamental frequency to the power value of the fundamental. This ratio is expressed in decibels (dBm) or a ratio

of the power in the 1Hz band to the power in the fundamental. When the required offset is specified, the phase noise is called a **dBc** value, which simply means dBm at a specified offset from the fundamental. By investigating jitter in the frequency domain, we get a better understanding of its effects on the desired application over the entire time record of the signal. It is mathematically possible to calculate an expected bit error rate given a phase noise plot.

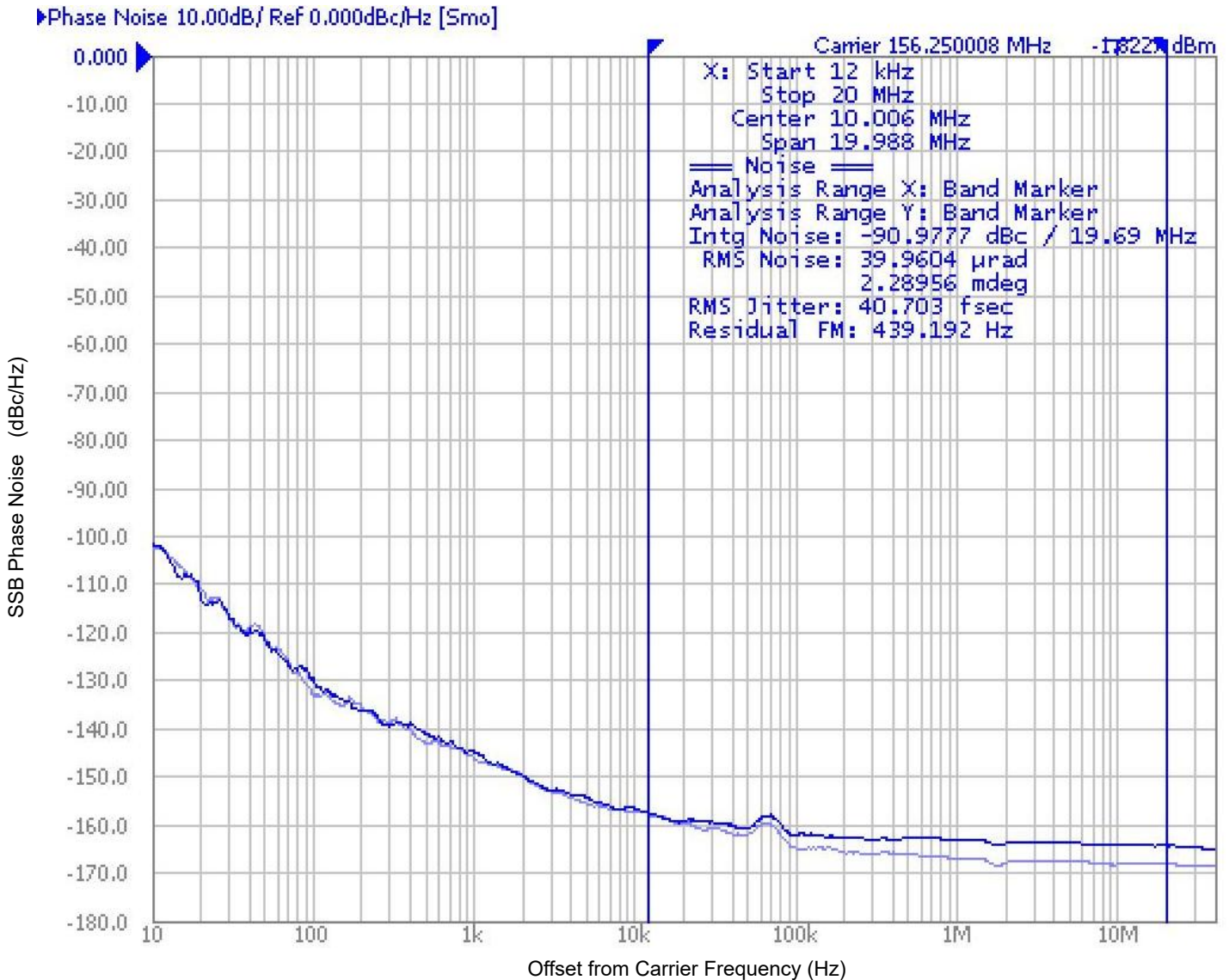

As with most timing specifications, phase noise measurements have issues relating to the limitations of the equipment. Often the noise floor of the equipment is higher than the noise floor of the device. This is illustrated above. The device meets the noise floor of what is shown, but can actually be lower. The phase noise is dependent on the input source and measurement equipment.

Measured using a Wenzel 156.25MHz Oscillator as the input source.

Parameter Measurement Information

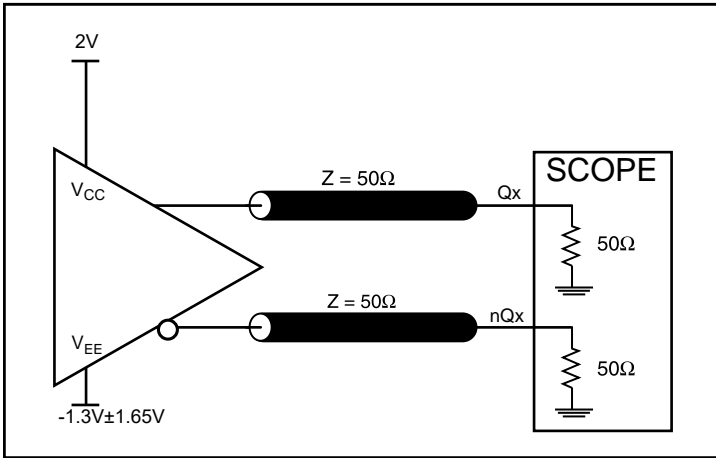

3.3V LVPECL Output Load AC Test Circuit

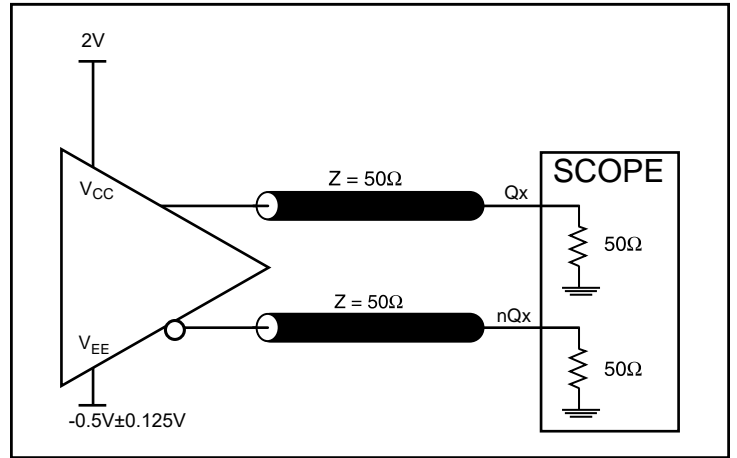

2.5V LVPECL Output Load AC Test Circuit

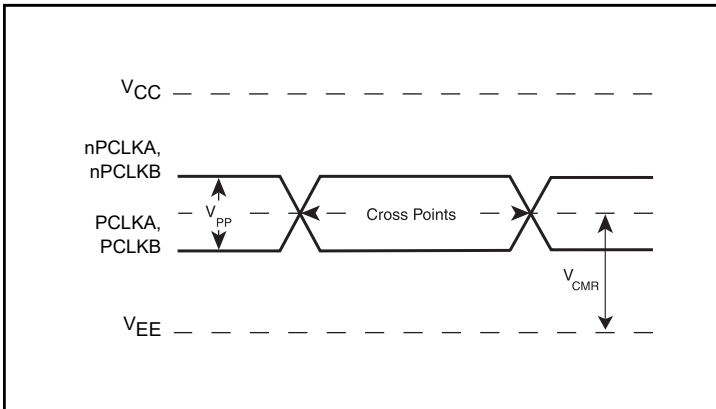

Differential Input Level

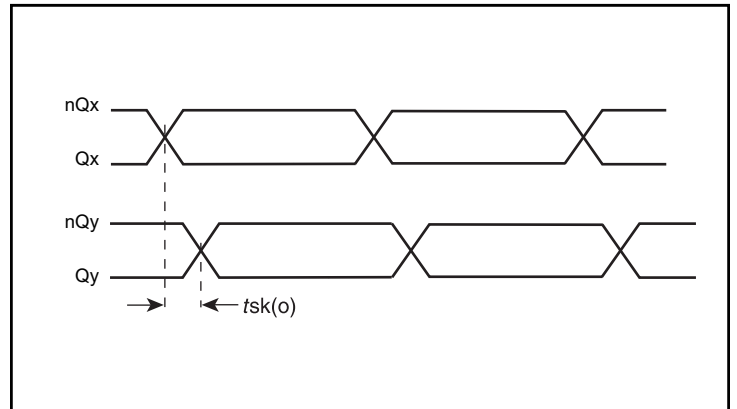

Output Skew

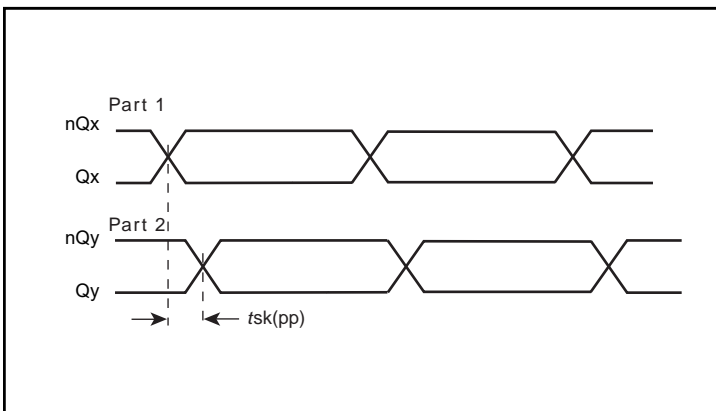

Part-to-Part Skew

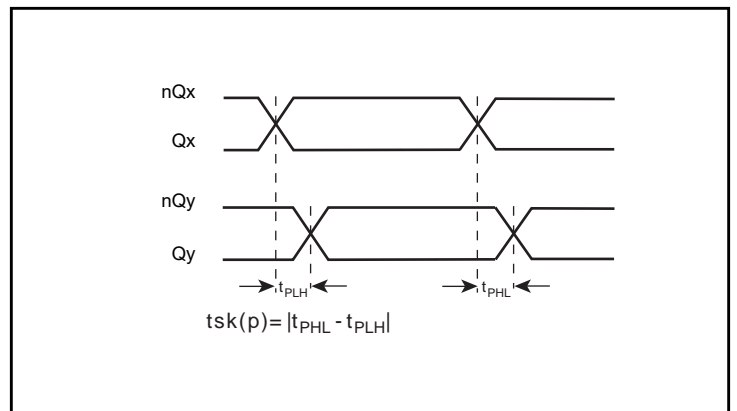

Pulse Skew

Parameter Measurement Information, continued

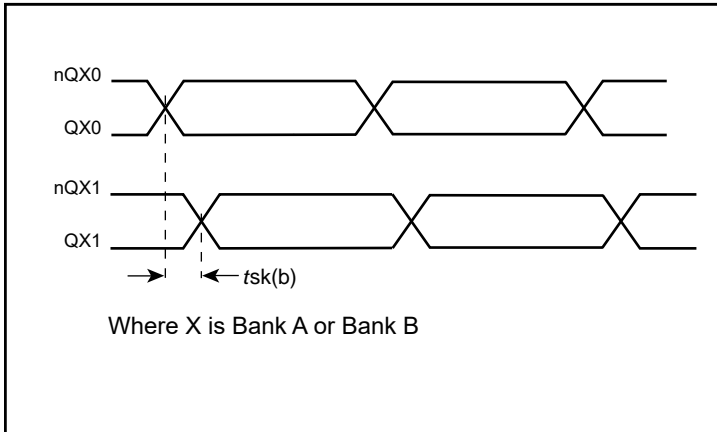

Bank Skew

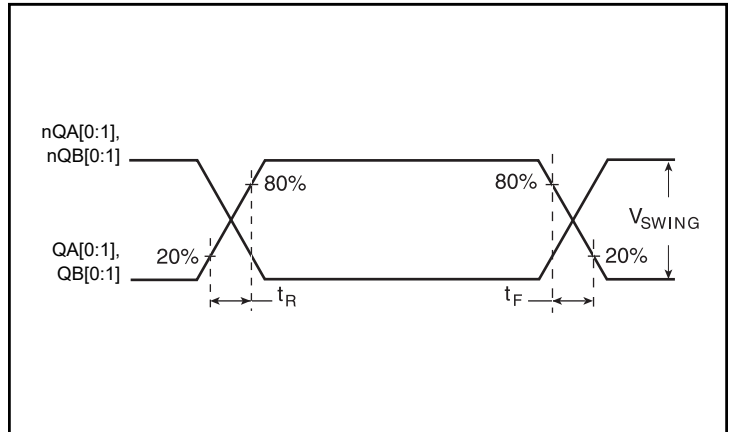

Output Rise/Fall Time

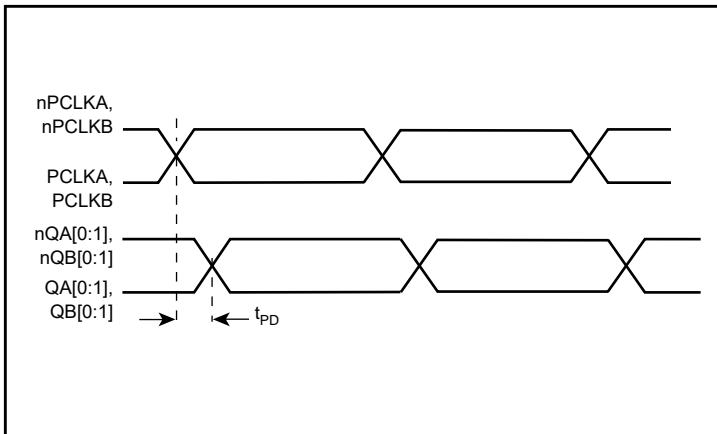

Propagation Delay

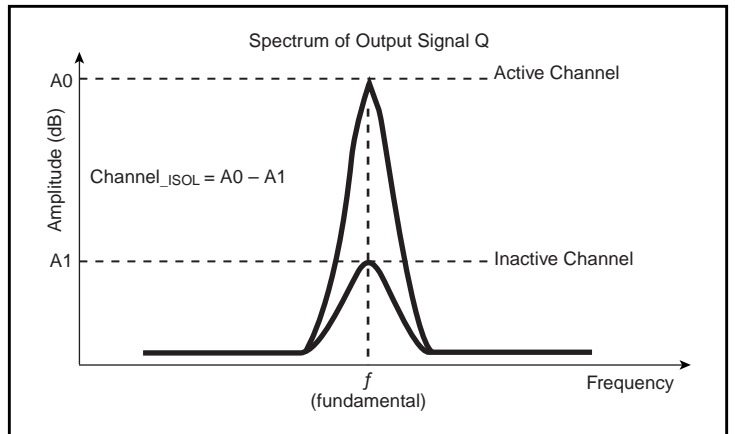

Channel Isolation

Applications Information

Wiring the Differential Input to Accept Single-Ended Levels

The IDT8SLVP2102I inputs can be interfaced to LVPECL, LVDS, CML or LVCMOS drivers. *Figure 1A* illustrates how to DC couple a single LVCMOS input to the IDT8SLVP2102I. The value of the series resistance R_S is calculated as the difference between the transmission line impedance and the driver output impedance. This resistor should be placed close to the LVCMOS driver. To avoid cross-coupling of single-ended LVCMOS signals, apply the LVCMOS signals to no more than one PCLK input.

A practical method to implement V_{th} is shown in *Figure 1B* below. The reference voltage $V_{th} = V_1 = V_{CC}/2$, is generated by the bias resistors R_1 and R_2 . The bypass capacitor (C_1) is used to help filter noise on the DC bias. This bias circuit should be located as close to the input pin as possible.

The ratio of R_1 and R_2 might need to be adjusted to position the V_1 in the center of the input voltage swing. For example, if the input clock swing is 2.5V and $V_{CC} = 3.3V$, R_1 and R_2 value should be adjusted to set V_1 at 1.25V. The values below apply when both the single-ended swing and V_{CC} are at the same voltage.

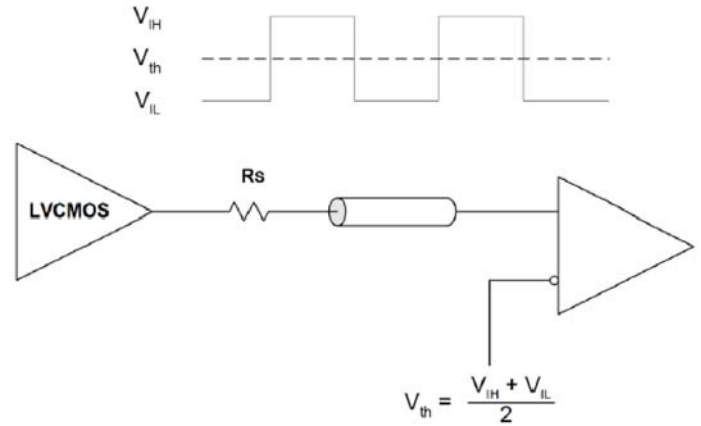

Figure 1A. DC-Coupling a Single LVCMOS Input to the IDT8SLVP2102I

When using single-ended signaling, the noise rejection benefits of differential signaling are reduced. Even though the differential input can handle full rail LVCMOS signaling, it is recommended that the amplitude be reduced, particularly if both input references are LVCMOS to minimize cross talk. The datasheet specifies a lower differential amplitude, however this only applies to differential signals. For single-ended applications, the swing can be larger, however V_{IL} cannot be less than $-0.3V$ and V_{IH} cannot be more than $V_{CC} + 0.3V$.

Figure 1B shows a way to attenuate the PCLK input level by a factor of two as well as matching the transmission line between the LVCMOS driver and the IDT8SLVP2102I at both the source and the

load. This configuration requires that the sum of the output impedance of the driver (R_o) and the series resistance (R_S) equals the transmission line impedance. R_3 and R_4 in parallel should equal the transmission line impedance; for most 50Ω applications, R_3 and R_4 will be 100Ω . The values of the resistors can be increased to reduce the loading for slower and weaker LVCMOS driver.

Though some of the recommended components of *Figure 1B* might not be used, the pads should be placed in the layout so that they can be utilized for debugging purposes. The datasheet specifications are characterized and guaranteed by using a differential signal.

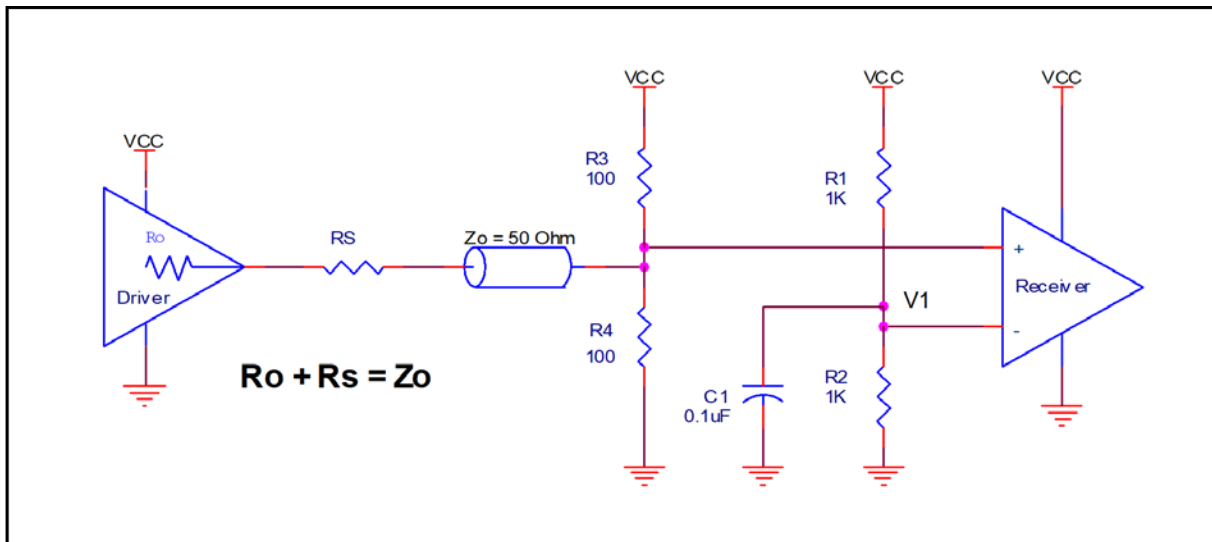

Figure 1B. Alternative DC Coupling a Single LVCMOS Input to the IDT8SLVP2102I

Recommendations for Unused Input and Output Pins

Inputs:

PCLK/nPCLK Inputs

For applications not requiring the use of a differential input, both the PCLK and nPCLK pins can be left floating. Though not required, but for additional protection, a 1k Ω resistor can be tied from PCLK to ground.

Outputs:

LVPECL Outputs

All unused LVPECL outputs can be left floating. We recommend that there is no trace attached. Both sides of the differential output pair should either be left floating or terminated.

3.3V LVPECL Clock Input Interface

The PCLK /nPCLK accepts LVPECL, LVDS, CML and other differential signals. Both signals must meet the V_{PP} and V_{CMR} input requirements. Figures 2A to 2E show interface examples for the PCLK/ nPCLK input driven by the most common driver types. The

input interfaces suggested here are examples only. If the driver is from another vendor, use their termination recommendation. Please consult with the vendor of the driver component to confirm the driver termination requirements.

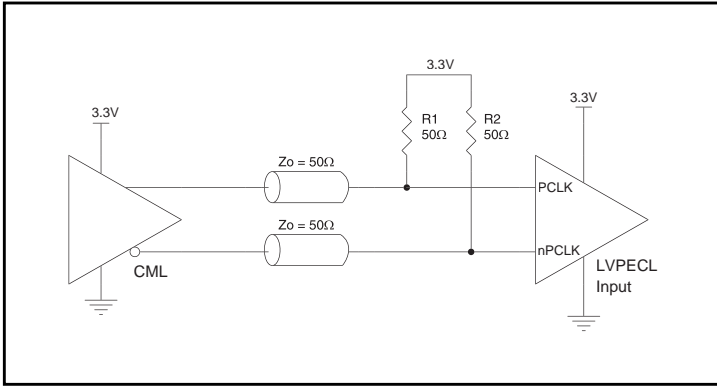

Figure 2A. PCLK/nPCLK Input Driven by a CML Driver

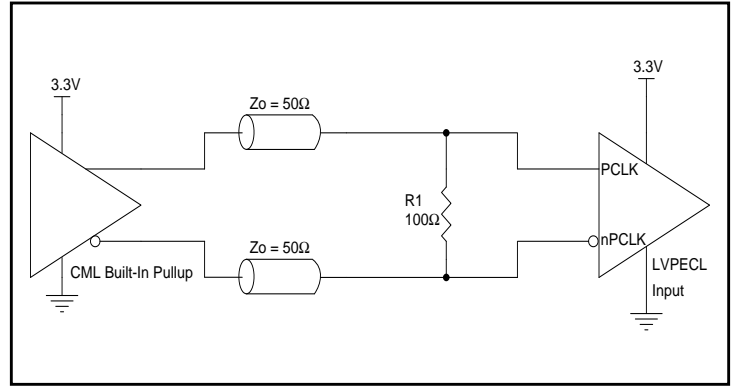

Figure 2B. PCLK/nPCLK Input Driven by a Built-In Pullup CML Driver

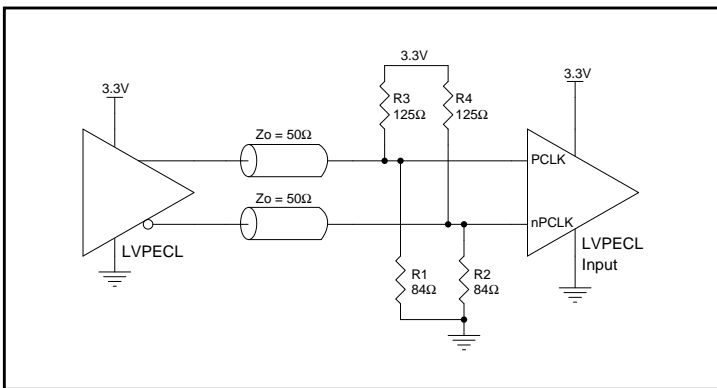

Figure 2C. PCLK/nPCLK Input Driven by a 3.3V LVPECL Driver

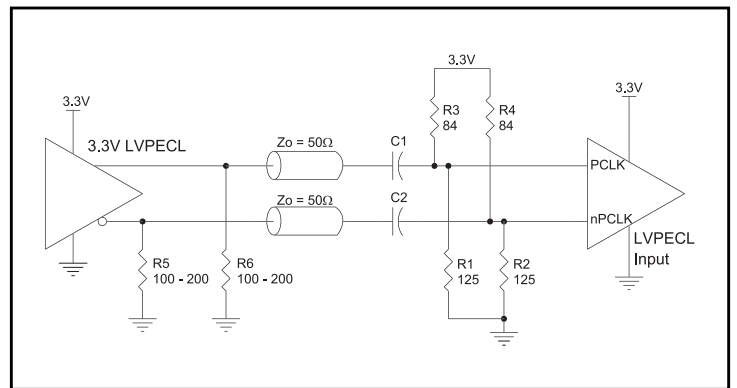

Figure 2D. PCLK/nPCLK Input Driven by a 3.3V LVPECL Driver with AC Couple

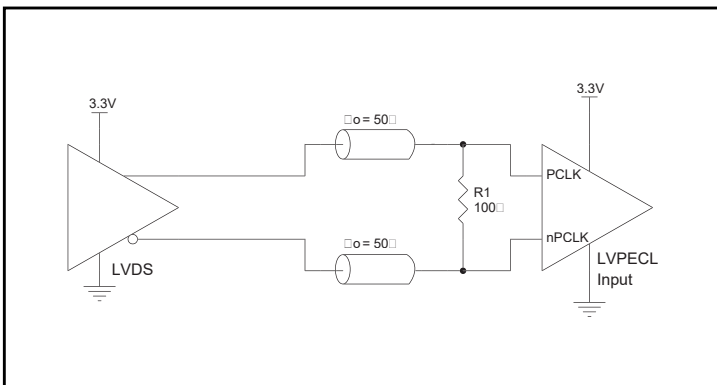

Figure 2E. PCLK/nPCLK Input Driven by a 3.3V LVDS Driver

2.5V LVPECL Clock Input Interface

The PCLK/nPCLK accepts LVPECL, LVDS, CML and other differential signals. Both signals must meet the V_{PP} and V_{CMR} input requirements. Figures 3A to 3E show interface examples for the PCLK/nPCLK input driven by the most common driver types. The

input interfaces suggested here are examples only. If the driver is from another vendor, use their termination recommendation. Please consult with the vendor of the driver component to confirm the driver termination requirements.

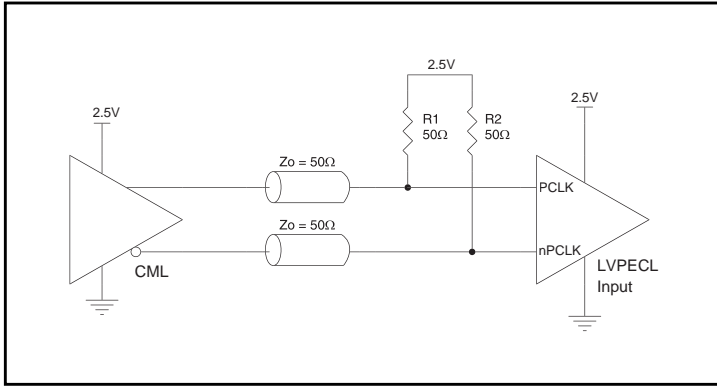

Figure 3A. PCLK/nPCLK Input Driven by a CML Driver

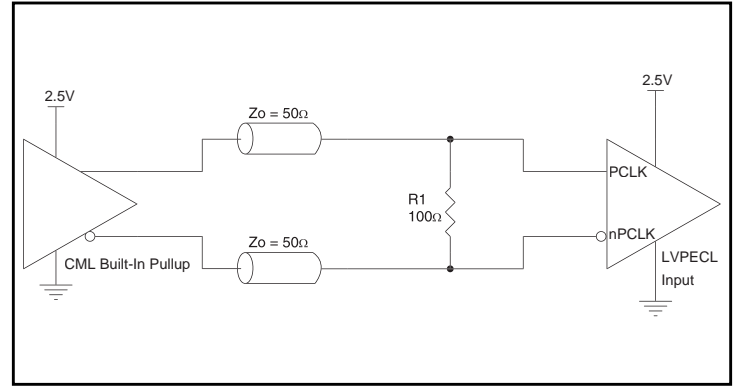

Figure 3B. PCLK/nPCLK Input Driven by a Built-In Pullup CML Driver

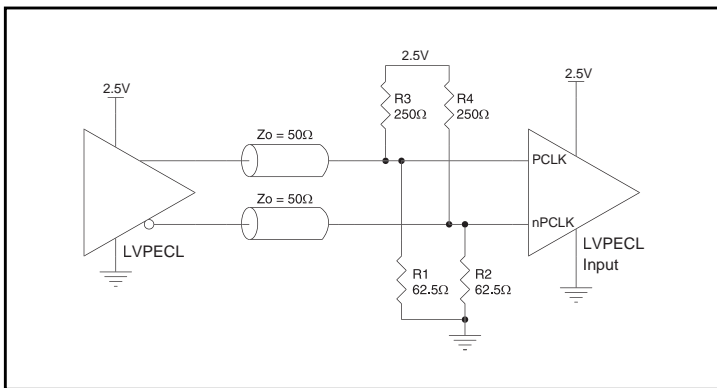

Figure 3C. PCLK/nPCLK Input Driven by a 2.5V LVPECL Driver

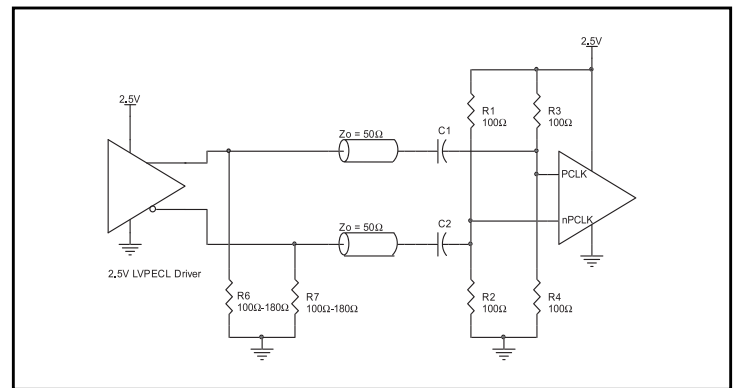

Figure 3D. PCLK/nPCLK Input Driven by a 2.5V LVPECL Driver with AC Couple

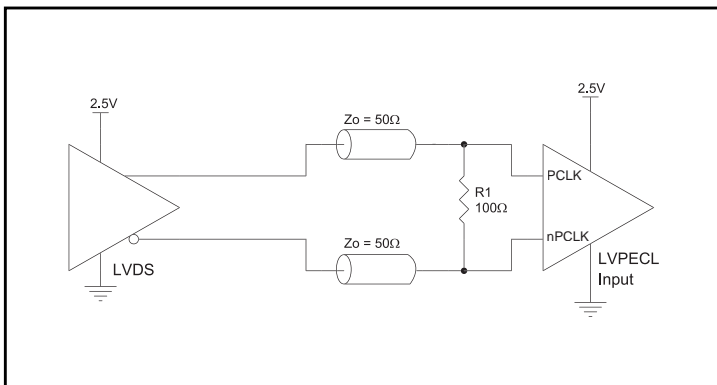

Figure 3E. PCLK/nPCLK Input Driven by a 2.5V LVDS Driver

VFQFPN EPAD Thermal Release Path

In order to maximize both the removal of heat from the package and the electrical performance, a land pattern must be incorporated on the Printed Circuit Board (PCB) within the footprint of the package corresponding to the exposed metal pad or exposed heat slug on the package, as shown in *Figure 4*. The solderable area on the PCB, as defined by the solder mask, should be at least the same size/shape as the exposed pad/slug area on the package to maximize the thermal/electrical performance. Sufficient clearance should be designed on the PCB between the outer edges of the land pattern and the inner edges of pad pattern for the leads to avoid any shorts.

While the land pattern on the PCB provides a means of heat transfer and electrical grounding from the package to the board through a solder joint, thermal vias are necessary to effectively conduct from the surface of the PCB to the ground plane(s). The land pattern must be connected to ground through these vias. The vias act as “heat pipes”. The number of vias (i.e. “heat pipes”) are application specific

and dependent upon the package power dissipation as well as electrical conductivity requirements. Thus, thermal and electrical analysis and/or testing are recommended to determine the minimum number needed. Maximum thermal and electrical performance is achieved when an array of vias is incorporated in the land pattern. It is recommended to use as many vias connected to ground as possible. It is also recommended that the via diameter should be 12 to 13mils (0.30 to 0.33mm) with 1oz copper via barrel plating. This is desirable to avoid any solder wicking inside the via during the soldering process which may result in voids in solder between the exposed pad/slug and the thermal land. Precautions should be taken to eliminate any solder voids between the exposed heat slug and the land pattern. Note: These recommendations are to be used as a guideline only. For further information, please refer to the Application Note on the Surface Mount Assembly of Amkor’s Thermally/ Electrically Enhance Leadframe Base Package, Amkor Technology.

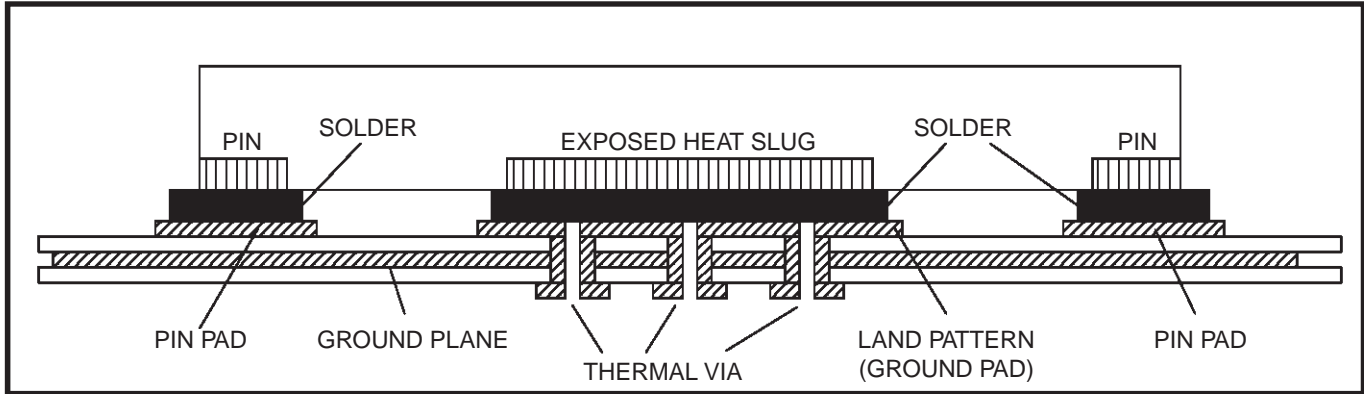

Figure 4. P.C. Assembly for Exposed Pad Thermal Release Path – Side View (drawing not to scale)

Termination for 3.3V LVPECL Outputs

The clock layout topology shown below is a typical termination for LVPECL outputs. The two different layouts mentioned are recommended only as guidelines.

The differential outputs are a low impedance follower output that generate ECL/LVPECL compatible outputs. Therefore, terminating resistors (DC current path to ground) or current sources must be used for functionality. These outputs are designed to drive 50Ω

transmission lines. Matched impedance techniques should be used to maximize operating frequency and minimize signal distortion.

Figures 5A and 5B show two different layouts which are recommended only as guidelines. Other suitable clock layouts may exist and it would be recommended that the board designers simulate to guarantee compatibility across all printed circuit and clock component process variations.

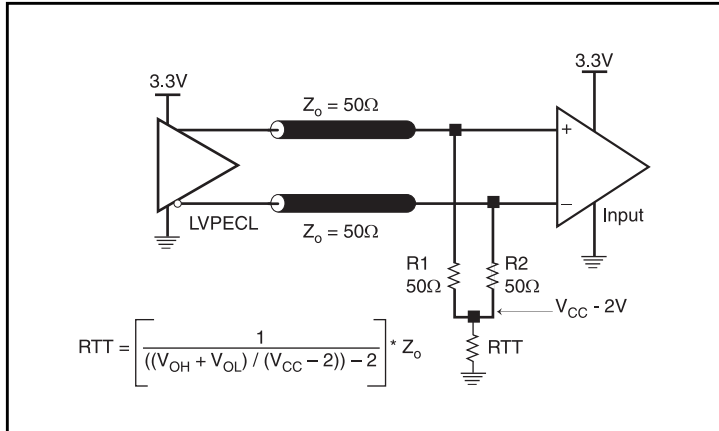

Figure 5A. 3.3V LVPECL Output Termination

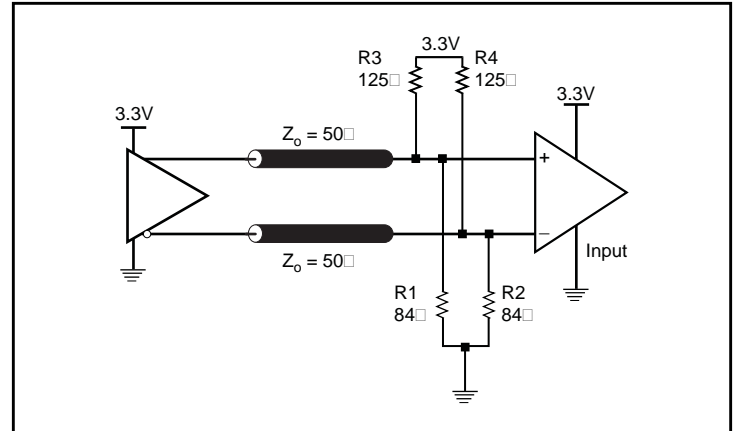

Figure 5B. 3.3V LVPECL Output Termination

Termination for 2.5V LVPECL Outputs

Figure 6A and Figure 6B show examples of termination for 2.5V LVPECL driver. These terminations are equivalent to terminating 50Ω to $V_{CC} - 2V$. For $V_{CC} = 2.5V$, the $V_{CC} - 2V$ is very close to ground

level. The R3 in Figure 6B can be eliminated and the termination is shown in Figure 6C.

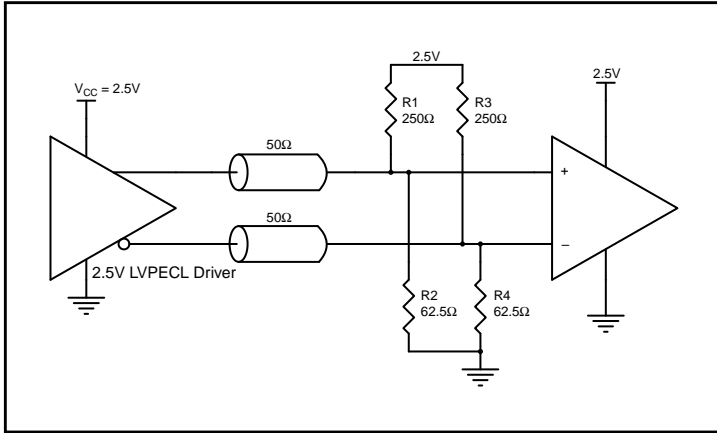

Figure 6A. 2.5V LVPECL Driver Termination Example

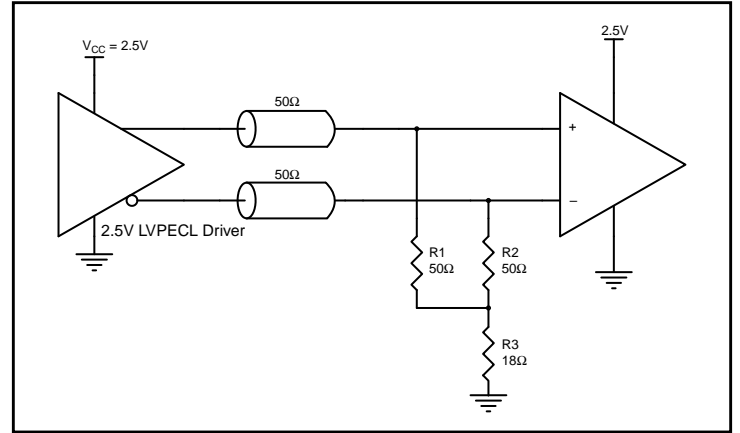

Figure 6B. 2.5V LVPECL Driver Termination Example

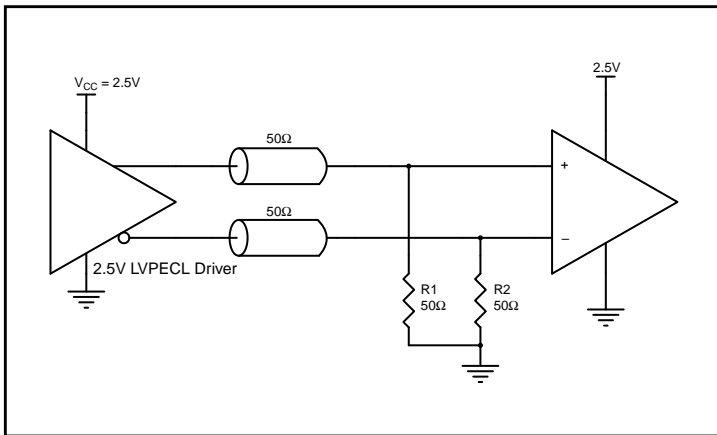

Figure 6C. 2.5V LVPECL Driver Termination Example

Power Considerations

This section provides information on power dissipation and junction temperature for the IDT8SLVP2102I. Equations and example calculations are also provided.

1. Power Dissipation.

The total power dissipation for the IDT8SLVP2102I is the sum of the core power plus the power dissipated in the load(s). The following is the power dissipation for $V_{CC} = 3.465V$, which gives worst case results.

NOTE: Please refer to Section 3 for details on calculating power dissipated in the load.

The maximum current at 85° is as follows:

$$I_{EE_MAX} = 56mA$$

- Power (core)_{MAX} = $V_{CC_MAX} * I_{EE_MAX} = 3.465V * 56mA = \mathbf{194.04mW}$
- Power (outputs)_{MAX} = **36mW/Loaded Output pair**
If all outputs are loaded, the total power is $4 * 36mW = \mathbf{144mW}$

$$\mathbf{Total\ Power_{_MAX}} (3.465V, \text{ with all outputs switching}) = 194.04mW + 144mW = \mathbf{338.04mW}$$

2. Junction Temperature.

Junction temperature, T_j , is the temperature at the junction of the bond wire and bond pad directly affects the reliability of the device. The maximum recommended junction temperature is 125°C. Limiting the internal transistor junction temperature, T_j , to 125°C ensures that the bond wire and bond pad temperature remains below 125°C.

The equation for T_j is as follows: $T_j = \theta_{JA} * Pd_total + T_A$

T_j = Junction Temperature

θ_{JA} = Junction-to-Ambient Thermal Resistance

Pd_total = Total Device Power Dissipation (example calculation is in section 1 above)

T_A = Ambient Temperature

In order to calculate junction temperature, the appropriate junction-to-ambient thermal resistance θ_{JA} must be used. Assuming no air flow and a multi-layer board, the appropriate value is 74.7°C/W per Table 5 below.

Therefore, T_j for an ambient temperature of 85°C with all outputs switching is:

$$85^\circ C + 0.338W * 74.7^\circ C/W = 110.2^\circ C. \text{ This is below the limit of } 125^\circ C.$$

This calculation is only an example. T_j will obviously vary depending on the number of loaded outputs, supply voltage, air flow and the type of board (multi-layer).

Table 5. Thermal Resistance θ_{JA} for 16-Lead VFQFPN, Forced Convection

θ_{JA} by Velocity			
Meters per Second	0	1	2.5
Multi-Layer PCB, JEDEC Standard Test Boards	74.7°C/W	65.3°C/W	58.5°C/W

3. Calculations and Equations.

The purpose of this section is to calculate the power dissipation for the LVPECL output pair.

LVPECL output driver circuit and termination are shown in *Figure 7*.

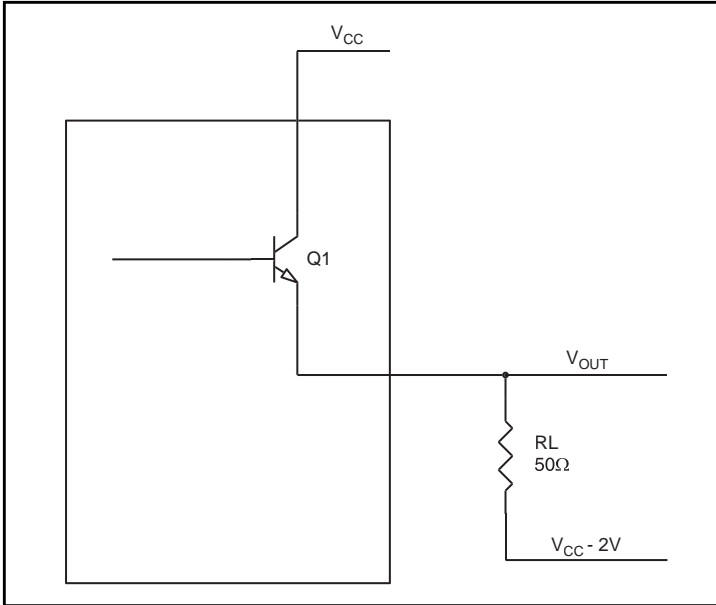

Figure 7. LVPECL Driver Circuit and Termination

To calculate power dissipation into the load, use the following equations which assume a 50Ω load, and a termination voltage of $V_{CC} - 2V$. These are typical calculations.

- For logic high, $V_{OUT} = V_{OH_MAX} = V_{CC_MAX} - 0.8V$
 $(V_{CC_MAX} - V_{OH_MAX}) = 0.8V$
- For logic low, $V_{OUT} = V_{OL_MAX} = V_{CC_MAX} - 1.4V$
 $(V_{CC_MAX} - V_{OL_MAX}) = 1.4V$

Pd_H is power dissipation when the output drives high.

Pd_L is the power dissipation when the output drives low.

$$Pd_H = [(V_{OH_MAX} - (V_{CC_MAX} - 2V))/R_L] * (V_{CC_MAX} - V_{OH_MAX}) = [(2V - (V_{CC_MAX} - V_{OH_MAX}))/R_L] * (V_{CC_MAX} - V_{OH_MAX}) = [(2V - 0.8V)/50\Omega] * 0.8V = \mathbf{19.2mW}$$

$$Pd_L = [(V_{OL_MAX} - (V_{CC_MAX} - 2V))/R_L] * (V_{CC_MAX} - V_{OL_MAX}) = [(2V - (V_{CC_MAX} - V_{OL_MAX}))/R_L] * (V_{CC_MAX} - V_{OL_MAX}) = [(2V - 1.4V)/50\Omega] * 1.4V = \mathbf{16.8mW}$$

Total Power Dissipation per output pair = $Pd_H + Pd_L = \mathbf{36mW}$

Case Temperature Considerations

The IDT8SLVP2102I supports applications in a natural convection environment that does not have any thermal conductivity through ambient air. The printed circuit board (PCB) is typically in a sealed enclosure without any natural or forced air flow and is kept at or below a specific temperature. The device package design incorporates an exposed pad (ePad) with enhanced thermal parameters which is soldered to the PCB where most of the heat escapes from the bottom exposed pad. For this type of application, it is recommended to use the junction-to-board thermal characterization parameter Ψ_{JB} (Psi-JB) to calculate the junction temperature (T_J) and ensure it does not exceed the maximum allowed junction temperature in the Absolute Maximum Rating table.

The junction-to-board thermal characterization parameter, Ψ_{JB} , is calculated using the following equation:

$T_J = T_{CB} + \Psi_{JB} \times P_d$, Where

T_J = Junction temperature at steady state condition in (°C).

T_{CB} = Case temperature (Bottom) at steady state condition in (°C).

Ψ_{JB} = Thermal characterization parameter to report the difference between junction temperature and the temperature of the board measured at the top surface of the board.

P_d = power dissipation (W) in desired operating configuration.

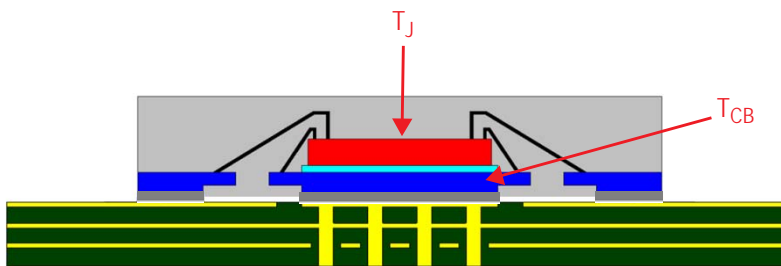

The ePad provides a low thermal resistance path for heat transfer to the PCB and represents the key pathway to transfer heat away from the IC to the PCB. It's critical that the connection of the exposed pad to the PCB is properly constructed to maintain the desired IC case temperature (T_{CB}). A good connection ensures that temperature at the exposed pad (T_{CB}) and the board temperature (T_B) are relatively the same. An improper connection can lead to increased junction temperature, increased power consumption and decreased electrical performance. In addition, there could be long-term reliability issues and increased failure rate.

Example Calculation for Junction Temperature (T_J): $T_J = T_{CB} + \Psi_{JB} \times P_d$

Package type:	16-Lead VFQFPN
Body size:	3mm x 3mm x0.9mm
ePad size:	1.7mm x 1.7mm
Thermal Via:	2 x 2 matrix
Ψ_{JB}	5.1 C/W
T_{CB}	105°C
P_d	0.338 W

For the variables above, the junction temperature is equal to 107°C. Since this is below the maximum junction temperature of 125°C, there are no long term reliability concerns. In addition, since the junction temperature at which the device was characterized using forced convection is 110.2°C, this device can function without the degradation of the specified AC or DC parameters.

Reliability Information

Table 6. θ_{JA} vs. Air Flow Table for a 16-Lead VFQFPN

θ_{JA} at 0 Air Flow			
Meters per Second	0	1	2.5
Multi-Layer PCB, JEDEC Standard Test Boards	74.7°C/W	65.3°C/W	58.5°C/W

Transistor Count

The transistor count for the 8SLVP2102 is: 261

Package Outline Drawings

The package outline drawings are appended at the end of this document and are accessible from the link below. The package information is the most current data available.

www.idt.com/document/psc/16-vfqfpn-package-outline-drawing-30-x-30-x-09-mm-05-mm-170-x-170-mm-epad-n1nlg16p2

Ordering Information

Table 7. Ordering Information

Part/Order Number	Marking	Package	Shipping Packaging	Temperature
8SLVP2102ANLGI	202AI	"Lead-Free" 16-Lead VFQFPN	Tube	-40°C to 85°C
8SLVP2102ANLGI8	202AI	"Lead-Free" 16-Lead VFQFPN	Tape & Reel, Pin 1 Orientation: EIA-481-C	-40°C to 85°C
8SLVP2102ANLGI/W	202AI	"Lead-Free" 16-Lead VFQFPN	Tape & Reel, Pin 1 Orientation: EIA-481-D	-40°C to 85°C

Table 8. Pin 1 Orientation in Tape and Reel Packaging

Part Number Suffix	Pin 1 Orientation	Illustration
8	Quadrant 1 (EIA-481-C)	
/W	Quadrant 2 (EIA-481-D)	

Revision History

Date	Description of Change
March 13, 2018	Updated the package outline drawings; however, no technical changes Completed other minor changes
August 21, 2017	Added a feature about case temperature to Features Added Case Temperature Considerations Updated the Package Outline Drawings. No mechanical changes.
February 26, 2014	Ordering Info: Changed Tray to Tube.
January 28, 2014	Changed Note 6 to read "V _{IL} should not be less than -0.3V. V _{IH} should not be higher than V _{CC} ."
January 30, 2013	Added Features Bullet: Differential PCLKA, nPCLKA and PCLKB, nPCLKB pairs can also accept single-ended LVCMOS levels. Added NOTE 8 to V _{PP} , V _{CMR} . Updated the "Wiring the Differential Input to Accept Single-Ended Levels" note.
July 31, 2012	Ordering Information Table - added additional row. Added Orientation Packaging Table.
June 20, 2012	Power Supply DC Characteristics Tables - changed I _{CC} to 180mA. Added "±1" to test conditions (PCN #651).

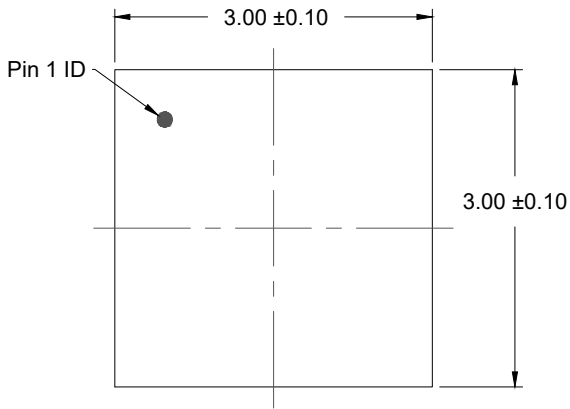

TOP VIEW

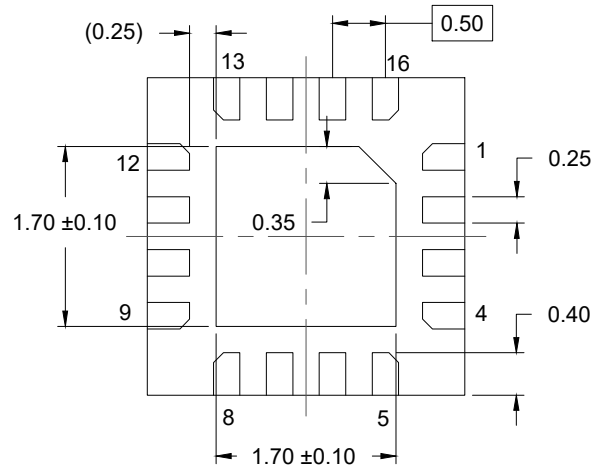

BOTTOM VIEW

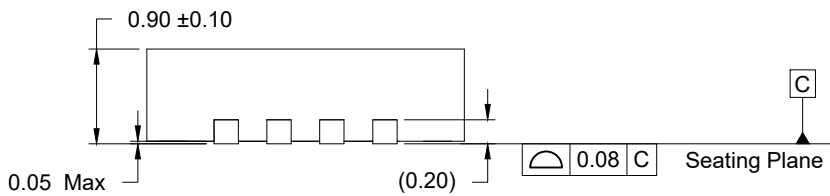

SIDE VIEW

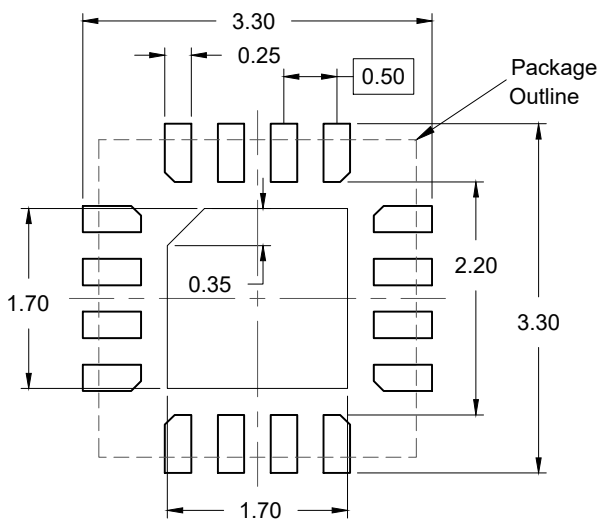

RECOMMENDED LAND PATTERN
(PCB Top View, NSMD Design)

NOTES:

1. JEDEC compatible.
2. All dimensions are in mm and angles are in degrees.
3. Use ± 0.05 mm for the non-toleranced dimensions.
4. Numbers in () are for references only.

IMPORTANT NOTICE AND DISCLAIMER

RENESAS ELECTRONICS CORPORATION AND ITS SUBSIDIARIES (“RENESAS”) PROVIDES TECHNICAL SPECIFICATIONS AND RELIABILITY DATA (INCLUDING DATASHEETS), DESIGN RESOURCES (INCLUDING REFERENCE DESIGNS), APPLICATION OR OTHER DESIGN ADVICE, WEB TOOLS, SAFETY INFORMATION, AND OTHER RESOURCES “AS IS” AND WITH ALL FAULTS, AND DISCLAIMS ALL WARRANTIES, EXPRESS OR IMPLIED, INCLUDING, WITHOUT LIMITATION, ANY IMPLIED WARRANTIES OF MERCHANTABILITY, FITNESS FOR A PARTICULAR PURPOSE, OR NON-INFRINGEMENT OF THIRD-PARTY INTELLECTUAL PROPERTY RIGHTS.

These resources are intended for developers who are designing with Renesas products. You are solely responsible for (1) selecting the appropriate products for your application, (2) designing, validating, and testing your application, and (3) ensuring your application meets applicable standards, and any other safety, security, or other requirements. These resources are subject to change without notice. Renesas grants you permission to use these resources only to develop an application that uses Renesas products. Other reproduction or use of these resources is strictly prohibited. No license is granted to any other Renesas intellectual property or to any third-party intellectual property. Renesas disclaims responsibility for, and you will fully indemnify Renesas and its representatives against, any claims, damages, costs, losses, or liabilities arising from your use of these resources. Renesas' products are provided only subject to Renesas' Terms and Conditions of Sale or other applicable terms agreed to in writing. No use of any Renesas resources expands or otherwise alters any applicable warranties or warranty disclaimers for these products.

(Disclaimer Rev.1.01 Jan 2024)

Corporate Headquarters

TOYOSU FORESIA, 3-2-24 Toyosu,
Koto-ku, Tokyo 135-0061, Japan
www.renesas.com

Trademarks

Renesas and the Renesas logo are trademarks of Renesas Electronics Corporation. All trademarks and registered trademarks are the property of their respective owners.

Contact Information

For further information on a product, technology, the most up-to-date version of a document, or your nearest sales office, please visit www.renesas.com/contact-us/.

Looking for pricing, stock, or lifecycle information?

Click below to explore more details on WIN SOURCE:

- ⊖ [View 8SLVP2102ANLGI/W on WIN SOURCE](#)
- ⊖ [Renesas Electronics America Information](#)

Optimize Your Supply Chain with WIN SOURCE Solutions

- ✓ Global Sourcing Solution
- ✓ Obsolete Management
- ✓ Cost Control Management
- ✓ Shortage Management
- ✓ Alternative Solution
- ✓ Excess Inventory Management