



**THE DATASHEET OF  
6127V1A270L.25FS**



# Non-Contacting Hall Effect Single Turn Position Sensor



## 6120 Series

### Features:

- 7/8" diameter
- Non-contacting
- Hall Effect
- Single turn
- Multiple styles available
- Custom models available



### Description:

The BI Technologies line of single-turn non-contacting hall-effect position sensors is 7/8" in diameter. Custom models are available. The hall-effect technology used makes this set of position sensors ideal for harsh environments where shock levels, vibration and temperature.

### Applications:

- Industrial grade joystick
- HVAC controls

## Model Styles Available

6121	1/8" Shaft, 1/4" Bushing
6124	6mm Shaft, 3/8" Bushing
6126	1/8" Shaft, 3/8" Bushing
6127	1/4" Shaft, 3/8" Bushing

Custom models are available; Contact Customer Service for special features

## Ordering Information

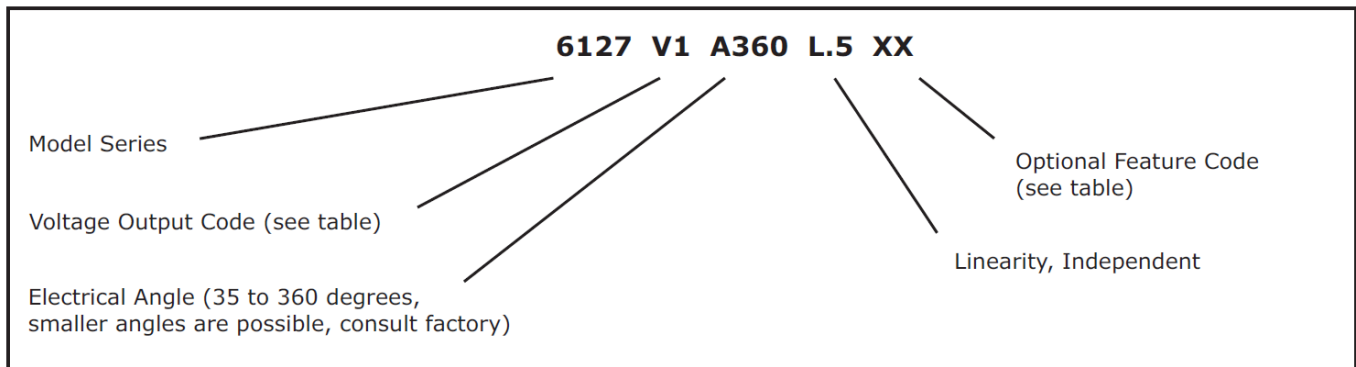

# Non-Contacting Hall Effect Single Turn Position Sensor



## 6120 Series

### Electrical Specifications<sup>1</sup>

Output voltage	0.25 Vdc to 4.75 Vdc typical (see Feature Codes table)
Output overvoltage limits	10 Vdc to -0.3 Vdc; output may be shorted to ground or supply without damage
Output current	±8 mA max.
Output load	1 kΩ min., 10 kΩ typical
Input voltage	4.5 to 5.5 Vdc
Supply voltage absolute limits	20 Vdc max., -10 Vdc min.
Independent linearity <sup>2</sup>	±0.5% (0.25% available)
Hysteresis	0.2% max.
Resolution	0.088° for 360° travel, 0.011° for 45° travel
Supply current	7.5 mA typical, 11 mA max.
Dielectric strength	750 V rms
Insulation resistance	1,000 megΩ min.
Electrostatic discharge (ESD)	Passes 2 kV human body model and 15 kV air discharge
Bulk current injection (BCI)	Passes 2-500 MHz at 200 mA
Actual electrical travel	360° typical (see ordering information)
Temperature coefficient of output voltage	±20 ppm/°C

### Mechanical Specifications

Total mechanical travel	360° continuous (320° with stop feature)
Bearing	Bearing bronze bushing
Weight	0.6 oz. typical
Static stop strength	40 in. oz.
Panel nut tightening torque	25 in. lb. max.
Supply voltage absolute limits	20 Vdc max., -10 Vdc min.
Independent linearity	±0.5% (0.25% available)
Hysteresis	0.2% max.
Resolution	0.088° for 360° travel, 0.011° for 45° travel

<sup>1</sup> Specifications subject to change without notice.

<sup>2</sup> Linearity is measured between 1% and 99% of input voltage.

# Non-Contacting Hall Effect Single Turn Position Sensor



## 6120 Series

### Environmental Specifications

Operating temperature range	-40°C to +125°C
Shock	Per MIL R-39023, 6 ms saw-tooth 100 G's
Vibration	Per MIL R-39023, 10 G's, 100 to 500 Hz
Moisture resistance, powered	Per MIL 202G, method 106G
Rotational life	10 million shaft revolutions
Storage temperature range	-55°C to +125°C

### Feature Codes

Voltage Output Codes		Optional Feature Codes	
V0	≤ 0.15 Vdc to ≥ 4.8 Vdc	ST	Stop (320°)
V1	0.2 Vdc to 4.8 Vdc	FS	Flatted Shaft (slot standard)
V2	0.25 Vdc to 4.75 Vdc	LT	Linearity Data
V3	0.5 Vdc to 4.5 Vdc	SL	Shaft Lock
V4	0.75 Vdc to 4.25 Vdc	CW	Reverse Direction
V5	1 Vdc to 4 Vdc		

When V0 is used the angle specified is the theoretical angle over which the output would vary if the output could actually reach 0% and 100% of Vcc.

# Non-Contacting Hall Effect Single Turn Position Sensor



## 6120 Series

### Outline Drawings

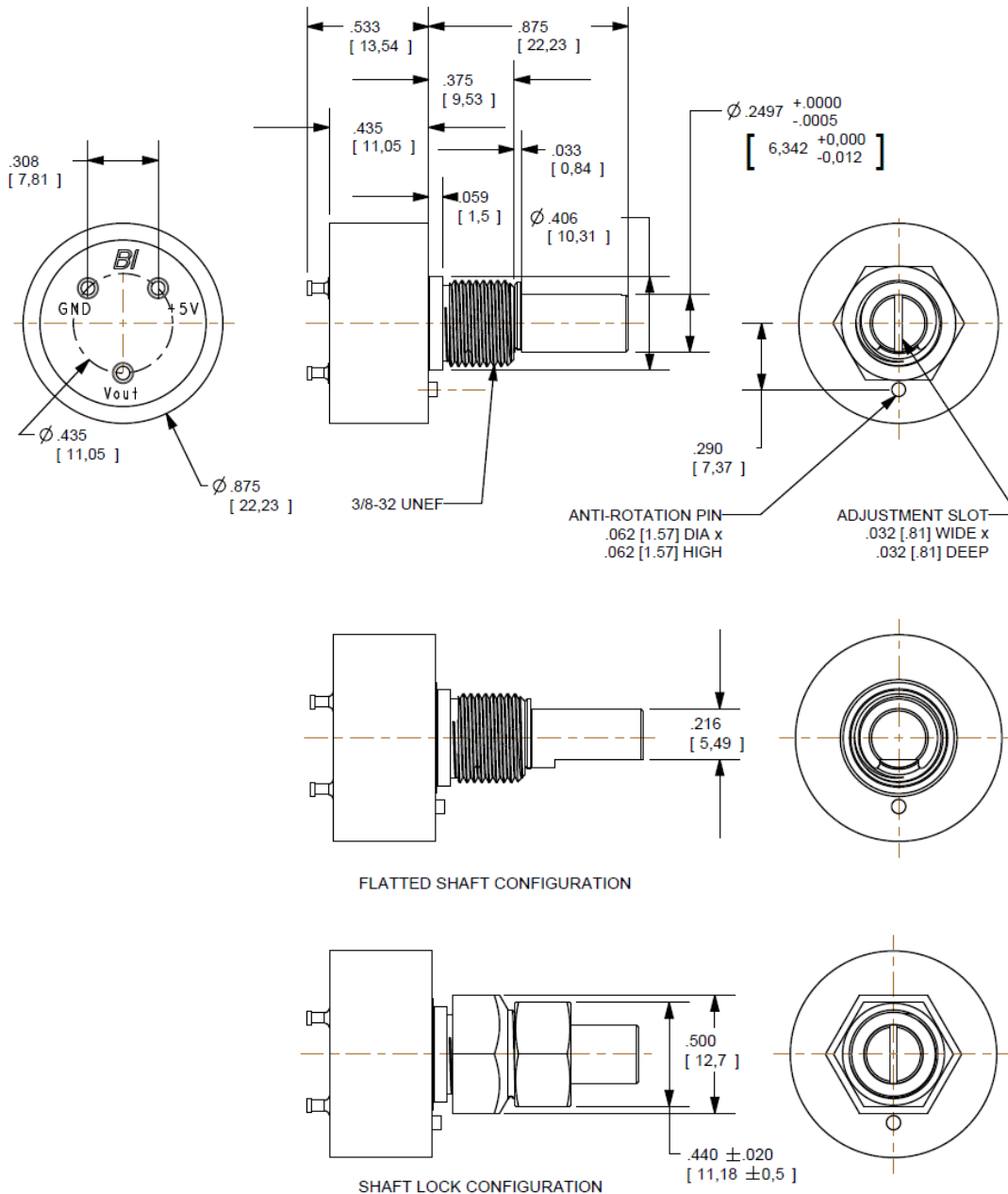

- NOTES:
1. UNIT SHIPS WITH NUT AND WASHER (NOT SHOWN).
  2. FOR SLOTTED OR FLATTED SHAFT, OUTPUT IS AT 50% IN POSITION SHOWN.
  3. DIMENSIONS: INCHES [mm].
  4. TOLERANCES:  $\pm .015$  [.38] UNLESS NOTED.

General Note  
 TT Electronics reserves the right to make changes in product specification without notice or liability. All information is subject to TT Electronics' own data and is considered accurate at time of going to print.

TT Electronics | BI Technologies  
 Circulo de la Amistad #102 PIMSA IV Mexicali B.C. Mexico C.P 21210  
 Ph: +1 714 447 2345  
 www.ttelectronics.com/bi-technologies

## Looking for pricing, stock, or lifecycle information?

Click below to explore more details on WIN SOURCE:

 [View 6127V1A270L.25FS on WIN SOURCE](#)

 [TT Electronics Information](#)

## Optimize Your Supply Chain with WIN SOURCE Solutions

-  Global Sourcing Solution
-  Obsolete Management
-  Cost Control Management
-  Shortage Management
-  Alternative Solution
-  Excess Inventory Management