



**THE DATASHEET OF
AD7357YRUZ-500RL7**



FEATURES

- Dual 14-bit SAR ADC**
- Simultaneous sampling**
- Throughput rate: 4.2 MSPS per channel**
- Specified for a V_{DD} of 2.5 V**
- Power dissipation: 36 mW at 4.2 MSPS**
- On-chip reference: $2.048\text{ V} \pm 0.25\%$, 6 ppm/°C**
- Dual conversion with read**
- High speed serial interface**
 - SPI-/QSPI-/MICROWIRE-/DSP-compatible
- 40°C to +125°C Y grade operation, –40°C to +85°C B grade operation**
- 16-lead TSSOP and 18-lead LFCSP packages**
- Qualified for automotive applications**

APPLICATIONS

- Automotive radar
- Data acquisition systems
- Motion control
- I and Q demodulation
- RFID readers

GENERAL DESCRIPTION

The [AD7357](#)¹ is a dual, 14-bit, high speed, low power, successive approximation analog-to-digital converter (ADC) that operates from a single 2.5 V power supply and features throughput rates up to 4.2 MSPS. The device contains two ADCs, each preceded by a low noise, wide bandwidth track-and-hold circuit that can handle input frequencies in excess of 110 MHz.

The conversion process and data acquisition use standard control inputs allowing for easy interfacing to microprocessors or digital signal processors (DSPs). The input signal is sampled on the falling edge of \overline{CS} ; a conversion is also initiated at this point. The conversion time is determined by the SCLK frequency.

The [AD7357](#) uses advanced design techniques to achieve very low power dissipation at high throughput rates. With a 2.5 V supply and a 4.2 MSPS throughput rate, the device consumes 14 mA typically. The device also offers flexible power and throughput rate management options.

The analog input range for the device is the differential common mode $\pm V_{REF}/2$. The [AD7357](#) has an on-chip 2.048 V reference that can be overdriven when an external reference is preferred.

The [AD7357](#) is available in a 16-lead thin shrink small outline package (TSSOP) and an 18-lead lead frame chip scale package (LFCSP).

¹ Protected by U.S. Patent No. 6,681,332.

Rev. E

[Document Feedback](#)

Information furnished by Analog Devices is believed to be accurate and reliable. However, no responsibility is assumed by Analog Devices for its use, nor for any infringements of patents or other rights of third parties that may result from its use. Specifications subject to change without notice. No license is granted by implication or otherwise under any patent or patent rights of Analog Devices. Trademarks and registered trademarks are the property of their respective owners.

FUNCTIONAL BLOCK DIAGRAM

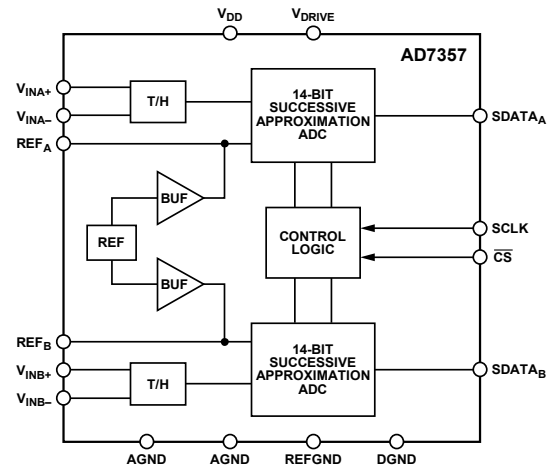

Figure 1.

PRODUCT HIGHLIGHTS

1. **Two Complete ADC Functions.**
These functions allow simultaneous sampling and conversion of two channels. The conversion result of both channels is simultaneously available on separate data lines or in succession on one data line if only one serial port is available.
2. **High Throughput with Low Power Consumption.**
The [AD7357](#) offers a 4.2 MSPS throughput rate with 36 mW power consumption.
3. **Simultaneous Sampling.**
The device features two standard successive approximation ADCs with accurate control of the sampling instant via a \overline{CS} input and once off conversion control.

Table 1. Related Devices

Generic	Resolution	Throughput	Analog Input
AD7356	12-bit	5 MSPS	Differential
AD7352	12-bit	3 MSPS	Differential
AD7266	12-bit	2 MSPS	Differential/single-ended
AD7866	12-bit	1 MSPS	Single-ended
AD7366	12-bit	1 MSPS	Single-ended bipolar
AD7367	14-bit	1 MSPS	Single-ended bipolar

TABLE OF CONTENTS

Features	1	Driving Differential Inputs	16
Applications	1	Voltage Reference	17
Functional Block Diagram	1	ADC Transfer Function	17
General Description	1	Modes of Operation	18
Product Highlights	1	Normal Mode	18
Revision History	2	Partial Power-Down Mode	18
Specifications	3	Full Power-Down Mode	19
Timing Specifications	6	Power-Up Times	20
Absolute Maximum Ratings	7	Power vs. Throughput Rate	20
ESD Caution	7	Serial Interface	21
Pin Configurations and Function Descriptions	8	Application Suggestions	22
Typical Performance Characteristics	10	Grounding and Layout	22
Terminology	12	Evaluating the AD7357 Performance	22
Theory of Operation	14	Outline Dimensions	23
Circuit Information	14	Ordering Guide	24
Converter Operation	14	Automotive Products	24
Analog Input Structure	14		
Analog Inputs	16		

REVISION HISTORY

12/15—Rev. D to Rev. E

Changes to Figure 3 and Table 5	8
---------------------------------------	---

10/15—Rev. C to Rev. D

Changes to Figure 20	16
----------------------------	----

6/15—Rev. B to Rev. C

Added 18-Lead LFCSP	Universal
Change to Features Section	1
Changes to Table 2	5
Added Figure 3, Renumbered Sequentially	8
Change to Circuit Information Section	13
Updated Outline Dimensions	22
Changes to Ordering Guide	22

8/11—Rev. A to Rev. B

Changes to Midscale Error Match Parameter, Table 2	3
Changes to Figure 21 and Figure 22	14
Added Voltage Reference Section	14

2/11—Rev. 0 to Rev. A

Changes to Features and Applications Sections	1
Changes to Table 2	3
Added AD7357WY Temperature Range to Endnote 1 in Table 3	5
Changes to SDATA _B , SDATA _A Pin Description	7
Changes to Figure 20 and Figure 22	14
Changes to Figure 31	18
Changes to Ordering Guide	20
Added Automotive Products Section	20

4/09—Revision 0: Initial Version

SPECIFICATIONS

$V_{DD} = 2.5 \pm 10\% V$, $V_{DRIVE} = 2.25 V$ to $3.6 V$, internal reference = $2.048 V$, $f_{SCLK} = 80 MHz$, $f_{SAMPLE} = 4.2 MSPS$, $T_A = T_{MIN}$ to T_{MAX}^1 , unless otherwise noted.

Table 2.

Parameter	AD7357B/AD7357Y			AD7357WY			Unit	Test Conditions/ Comments
	Min	Typ	Max	Min	Typ	Max		
DYNAMIC PERFORMANCE								
Signal-to-Noise Ratio (SNR)	74.5	76.5		74.5	76.5		dB	$f_{IN} = 500 kHz$ sine wave
Signal-to-Noise and Distortion (SINAD) ²	74	76		74	76		dB	–40°C to +25°C only
Total Harmonic Distortion (THD) ²		–83	–80	73.5	–83	–80	dB	–40°C to +25°C only
Spurious Free Dynamic Range (SFDR)		–85	–82		–85	–82	dB	–40°C to +25°C only
Intermodulation Distortion (IMD) ²						–81	dB	–40°C to +25°C only
Second-Order Terms		–86			–86		dB	$f_a = 1 MHz + 50 kHz$, $f_b = 1 MHz - 50 kHz$
Third-Order Terms		–79			–79		dB	
ADC to ADC Isolation ²		–100			–100		dB	$f_{IN} = 1 MHz$, $f_{NOISE} =$ 100 kHz to 2.5 MHz
CMRR ²		–100			–100		dB	$f_{NOISE} = 100 kHz$ to 2.5 MHz
SAMPLE-AND-HOLD								
Aperture Delay			3.5			3.5	ns	
Aperture Delay Match			40			40	ps	
Aperture Jitter		16			16		ps	
Full Power Bandwidth								
At 3 dB		110			110		MHz	
At 0.1 dB		77			77		MHz	At 0.1 dB
DC ACCURACY								
Resolution	14			14			Bits	
Integral Nonlinearity (INL) ²		±2	±3		±2	±3	LSB	
Differential Nonlinearity (DNL) ²		±0.5	±0.99		±0.5	±0.99	LSB	Guaranteed no missed codes to 14 bits
Positive Full-Scale Error ²			±20			±20	LSB	
Positive Full-Scale Error Match ²			±20			±20	LSB	
Midscale Error ²			0/35			0/38	LSB	
Midscale Error Match ²			±12			±15	LSB	
Negative Full-Scale Error ²			±20			±20	LSB	
Negative Full-Scale Error Match ²			±20			±20	LSB	
ANALOG INPUT								
Fully Differential Input Range (V_{IN+} and V_{IN-})			$V_{CM} \pm V_{REF}/2$			$V_{CM} \pm V_{REF}/2$	V	V_{CM} = common-mode voltage; V_{IN+} and V_{IN-} must remain within GND and V_{DD}
Common-Mode Voltage Range	0.5		1.6	0.5		1.6	V	The voltage around which V_{IN+} and V_{IN-} are centered
DC Leakage Current		±0.5	±5		±0.5	±5	μA	
Input Capacitance		32			32		pF	When in track mode
		8			8		pF	When in hold mode

Parameter	AD7357B/AD7357Y			AD7357WY			Unit	Test Conditions/ Comments
	Min	Typ	Max	Min	Typ	Max		
REFERENCE INPUT/OUTPUT								
V_{REF} Input Voltage Range	2.048 + 0.1		V_{DD}	2.048 + 0.1		V_{DD}	V	
V_{REF} Input Current		0.3	0.45		0.3	0.45	mA	When in reference overdrive mode
V_{REF} Output Voltage	2.038		2.058	2.038		2.058	V	$\pm 2.048\text{ V} \pm 0.5\%$ maximum at $V_{DD} = 2.5\text{ V} \pm 5\%$
	2.043		2.053	2.043		2.053	V	2.048 V $\pm 0.25\%$ maximum at $V_{DD} = 2.5\text{ V} \pm 5\%$ and 25°C
V_{REF} Temperature Coefficient		6	20		6	20	ppm/°C	
V_{REF} Long Term Stability		100			100		ppm	For 1000 hours
V_{REF} Thermal Hysteresis		50			50		ppm	
V_{REF} Noise		60			60		$\mu\text{V rms}$	
V_{REF} Output Impedance		1			1		Ω	
LOGIC INPUTS								
Input Voltage								
High, V_{INH}	$0.6 \times V_{DRIVE}$			$0.6 \times V_{DRIVE}$			V	
Low, V_{INL}			$0.3 \times V_{DRIVE}$			$0.3 \times V_{DRIVE}$	V	
Input Current, I_{IN}			± 1			± 1	μA	$V_{IN} = 0\text{ V or }V_{DRIVE}$
Input Capacitance, C_{IN}		3			3		pF	
LOGIC OUTPUTS								
Output Voltage								
High, V_{OH}	$V_{DRIVE} - 0.2$			$V_{DRIVE} - 0.2$			V	
Low, V_{OL}			0.2			0.2	V	
Floating State Leakage Current			± 1			± 1	μA	
Floating State Output Capacitance		5.5			5.5		pF	
Output Coding	Straight binary			Straight binary				
CONVERSION RATE								
Conversion Time	$t_2 + 15.5 \times t_{SCLK}$			$t_2 + 15.5 \times t_{SCLK}$			ns	
Track-and-Hold Acquisition Time ²			33			33	ns	Full-scale step input
Throughput Rate			4.2			4.2	MSPS	
POWER REQUIREMENTS								
V_{DD}	2.25		2.75	2.25		2.75	V	Nominal $V_{DD} = 2.5\text{ V}$
V_{DRIVE}^3	2.25		3.6	2.25		3.6	V	
I_{TOTAL}^4								Digital inputs = 0 V or V_{DRIVE}
Normal Mode								
Operational		14	20		14	20	mA	
Static		6	7.6		6	7.6	mA	SCLK on or off
Power-Down Mode								
Partial		3.5	4.5		3.5	4.5	mA	SCLK on or off
Full		5	40		5	40	μA	SCLK on or off

Parameter	AD7357B/AD7357Y			AD7357WY			Unit	Test Conditions/ Comments
	Min	Typ	Max	Min	Typ	Max		
Power Dissipation								
Normal Mode								
Operational		36	59		36	59	mW	
Static		16	21		16	21	mW	SCLK on or off
Power-Down Mode								
Partial		9.5	11.5		9.5	11.5	mW	SCLK on or off
Full		16	110		16	110	μW	SCLK on or off

¹ Temperature ranges are as follows: AD7357Y: -40°C to +125°C; AD7357B (TSSOP): -40°C to +85°C; AD7357B (LFCSP): -40°C to +125°C; AD7357WY: -40°C to +125°C.

² See the Terminology section.

³ The interface is functional with V_{DRIVE} voltages down to 1.8 V. In this condition, the SCLK speed may need to be slowed down. See the access and hold times in the Timing Specifications section.

⁴ I_{TOTAL} is the total current flowing in V_{DD} and V_{DRIVE}.

TIMING SPECIFICATIONS

$V_{DD} = 2.5 \text{ V} \pm 10\%$, $V_{DRIVE} = 2.25 \text{ V}$ to 3.6 V , internal reference = 2.048 V , $T_A = T_{MAX}$ to T_{MIN} ¹, unless otherwise noted.

Table 3.

Parameter	Limit at T_{MIN} , T_{MAX}	Unit	Description
f_{SCLK}	500	kHz min	
	80	MHz max	
$t_{CONVERT}$	$t_2 + 15.5 \times t_{SCLK}$	ns min	$t_{SCLK} = 1/f_{SCLK}$
t_{QUIET}	5	ns min	Minimum time between end of serial read and next falling edge of \overline{CS}
t_2	5	ns min	\overline{CS} to SCLK setup time
t_3^2	6	ns max	Delay from \overline{CS} until $SDATA_A$ and $SDATA_B$ are three-state disabled
$t_4^{2,3}$			Data access time after SCLK falling edge
	12.5	ns max	$1.8 \text{ V} \leq V_{DRIVE} < 2.25 \text{ V}$
	11	ns max	$2.25 \text{ V} \leq V_{DRIVE} < 2.75 \text{ V}$
	9.5	ns max	$2.75 \text{ V} \leq V_{DRIVE} < 3.3 \text{ V}$
	9	ns max	$3.3 \text{ V} \leq V_{DRIVE} \leq 3.6 \text{ V}$
t_5	5	ns min	SCLK low pulse width
t_6	5	ns min	SCLK high pulse width
t_7^2			SCLK to data valid hold time
	3.5	ns min	$1.8 \text{ V} \leq V_{DRIVE} < 2.75 \text{ V}$
	3	ns min	$2.75 \text{ V} \leq V_{DRIVE} \leq 3.6 \text{ V}$
t_8	9.5	ns max	\overline{CS} rising edge to $SDATA_A$, $SDATA_B$, high impedance
t_9	5	ns min	\overline{CS} rising edge to falling edge pulse width
t_{10}^2	4.5	ns min	SCLK falling edge to $SDATA_A$, $SDATA_B$, high impedance
	9.5	ns max	SCLK falling edge to $SDATA_A$, $SDATA_B$, high impedance
Latency	1 conversion latency		

¹ Temperature ranges are as follows: [AD7357Y](#): -40°C to $+125^\circ\text{C}$; [AD7357B](#) (TSSOP): -40°C to $+85^\circ\text{C}$; [AD7357B](#) (LFCSP): -40°C to $+125^\circ\text{C}$; [AD7357WY](#): -40°C to $+125^\circ\text{C}$.

² Specified with a load capacitance of 10 pF on $SDATA_A$ and $SDATA_B$.

³ The time required for the output to cross 0.4 V or 2.4 V.

ABSOLUTE MAXIMUM RATINGS

Table 4.

Parameter	Rating
V _{DD} to AGND, DGND, REFGND	−0.3 V to +3 V
V _{DRIVE} to AGND, DGND, REFGND	−0.3 V to +5 V
V _{DD} to V _{DRIVE}	−5 V to +3 V
AGND to DGND to REFGND	−0.3 V to +0.3 V
Analog Input Voltages ¹ to AGND	−0.3 V to V _{DD} + 0.3 V
Digital Input Voltages ² to DGND	−0.3 V to V _{DRIVE} + 0.3V
Digital Output Voltages ³ to DGND	−0.3 V to V _{DRIVE} + 0.3 V
Input Current to Any Pin Except Supplies ⁴	±10 mA
Operating Temperature Range	
AD7357Y	−40°C to +125°C
AD7357B (TSSOP)	−40°C to +85°C
AD7357B (LFCSP)	−40°C to +125°C
AD7357WY	−40°C to +125°C
Storage Temperature Range	−65°C to +150°C
Junction Temperature	150°C
TSSOP Package	
θ_{JA} Thermal Impedance	143°C/W
θ_{JC} Thermal Impedance	45°C/W
LFCSP Package	
θ_{JA} Thermal Impedance	44°C/W
θ_{JC} Thermal Impedance	22°C/W
Lead Temperature, Soldering	
Reflow Temperature (10 sec to 30 sec)	255°C
ESD	2 kV

¹ Analog input voltages are V_{INA+}, V_{INA-}, V_{INB+}, V_{INB-}, REF_A, and REF_B.

² Digital input voltages are CS and SCLK.

³ Digital output voltages are SDATA_A and SDATA_B.

⁴ Transient currents of up to 100 mA do not cause SCR latch-up.

Stresses at or above those listed under Absolute Maximum Ratings may cause permanent damage to the product. This is a stress rating only; functional operation of the product at these or any other conditions above those indicated in the operational section of this specification is not implied. Operation beyond the maximum operating conditions for extended periods may affect product reliability.

ESD CAUTION



ESD (electrostatic discharge) sensitive device. Charged devices and circuit boards can discharge without detection. Although this product features patented or proprietary protection circuitry, damage may occur on devices subjected to high energy ESD. Therefore, proper ESD precautions should be taken to avoid performance degradation or loss of functionality.

PIN CONFIGURATIONS AND FUNCTION DESCRIPTIONS

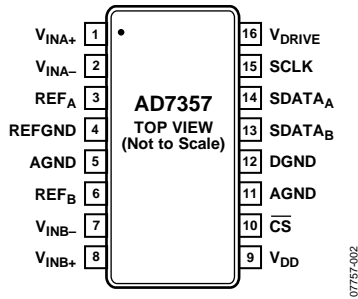
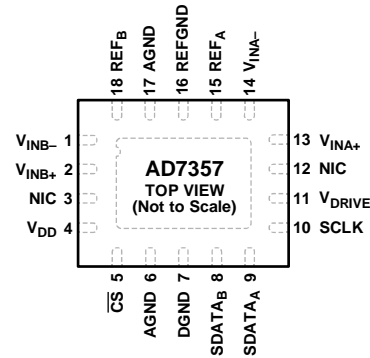

Figure 2. Pin Configuration, TSSOP



NOTES
 1. NIC = NO INTERNAL CONNECTION.
 2. THE EXPOSED PAD IS NOT CONNECTED INTERNALLY.
 FOR INCREASED RELIABILITY OF THE SOLDER JOINTS AND FOR MAXIMUM THERMAL CAPABILITY, SOLDER THE EXPOSED PAD TO THE PRINTED CIRCUIT BOARD (PCB).

Figure 3. Pin Configuration, LFCSP

Table 5. Pin Function Descriptions

Pin No.		Mnemonic	Description
TSSOP	LFCSP		
1, 2	13, 14	V_{INA+}, V_{INA-}	Analog Inputs of ADC A. These analog inputs form a fully differential pair.
3, 6	15, 18	REF_A, REF_B	Reference Decoupling Capacitor Pins. Decoupling capacitors are connected between these pins and the REFGND pin to decouple the reference buffer for each respective ADC. It is recommended to decouple each reference pin with a 10 μ F capacitor. Provided that the output is buffered, take the on-chip reference from these pins and apply it externally to the rest of the system. The nominal internal reference voltage is 2.048 V and appears at these pins. These pins can also be overdriven by an external reference. The input voltage range for the external reference is 2.048 V + 100 mV to V_{DD} .
4	16	REFGND	Reference Ground. This is the ground reference point for the reference circuitry on the AD7357 . Refer any external reference signal to this REFGND voltage. Decoupling capacitors must be placed between this pin and the REF_A and REF_B pins.
5, 11	6, 17	AGND	Analog Ground. This is the ground reference point for all analog circuitry on the AD7357 . Refer all analog input signals to this AGND voltage. The AGND and DGND voltages must ideally be at the same potential and must not be more than 0.3 V apart, even on a transient basis.
7, 8	1, 2	V_{INB-}, V_{INB+}	Analog Inputs of ADC B. These analog inputs form a fully differential pair.
9	4	V_{DD}	Power Supply Input. The V_{DD} range for the AD7357 is 2.5 V \pm 10%. Decouple the supply to AGND with a 0.1 μ F capacitor and a 10 μ F tantalum capacitor.
10	5	\overline{CS}	Chip Select. Active low, logic input. This input provides the dual function of initiating conversions on the AD7357 and framing the serial data transfer.
12	7	DGND	Digital Ground. This is the ground reference point for all digital circuitry on the AD7357 . Connect this pin to the DGND plane of a system. The DGND and AGND voltages must ideally be at the same potential and must not be more than 0.3 V apart, even on a transient basis.
13, 14	8, 9	$SDATA_B, SDATA_A$	Serial Data Outputs. The data output is supplied to each pin as a serial data stream. The bits are clocked out on the falling edge of the SCLK input. 16 SCLK falling edges are required to access the 14 bits of data from the AD7357 . The data simultaneously appears on both data output pins from the simultaneous conversions of both ADCs. The data stream consists of two leading zeros, followed by the 14 bits of conversion data. The data is provided MSB first. If \overline{CS} is held low for 18 SCLK cycles rather than 16, then two trailing zeros appear after the 14 bits of data. If \overline{CS} is held low for an additional 18 SCLK cycles on either $SDATA_A$ or $SDATA_B$, the data from the other ADC follows on the $SDATA_x$ pins. This allows data from a simultaneous conversion on both ADCs to gather in serial format on either $SDATA_A$ or $SDATA_B$.
15	10	SCLK	Serial Clock. Logic input. A serial clock input provides the SCLK for accessing the data from the AD7357 . This clock is also used as the clock source for the conversion process.

Pin No.		Mnemonic	Description
TSSOP	LFCSP		
16	11	V _{DRIVE}	Logic Power Supply Input. The voltage supplied at this pin determines at what voltage the interface operates. This pin is decoupled to DGND. The voltage at this pin may be different than at V _{DD} .
Not applicable	3, 12	NIC	No Internal Connection. These pins are not connected internally.
Not applicable		EPAD	Exposed Pad. The exposed pad is not connected internally. For increased reliability of the solder joints and for maximum thermal capability, solder the exposed pad to the printed circuit board (PCB).

TYPICAL PERFORMANCE CHARACTERISTICS

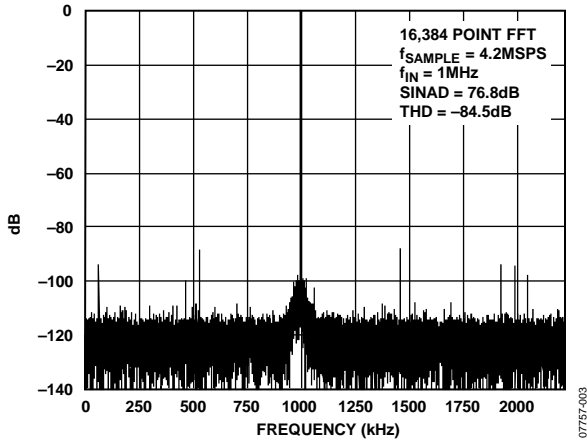

Figure 4. Typical FFT

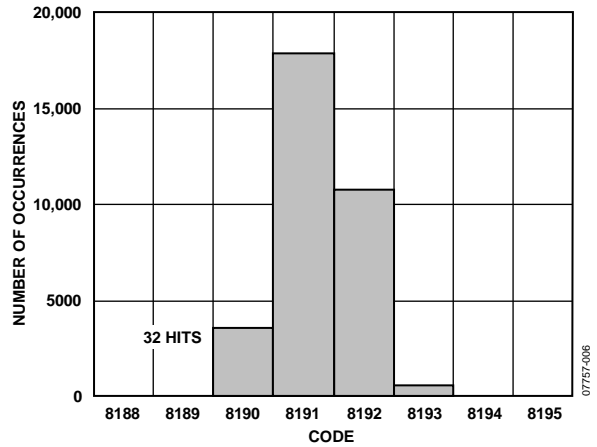

Figure 7. Histogram of Codes

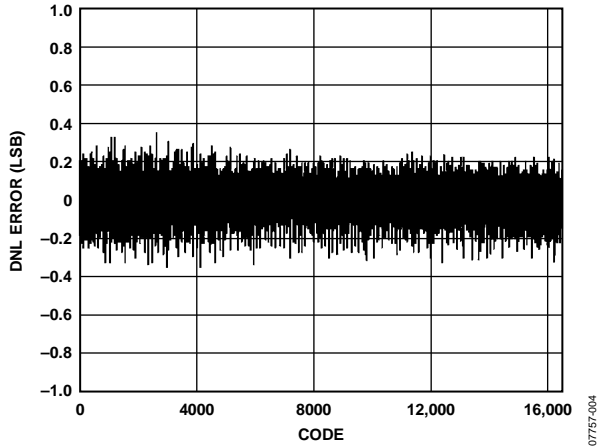

Figure 5. Typical DNL

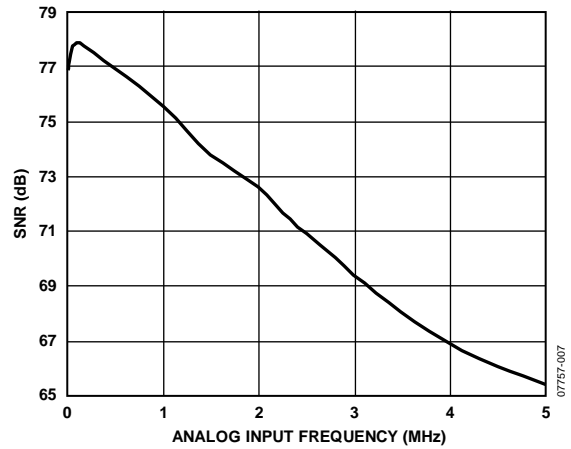

Figure 8. SNR vs. Analog Input Frequency

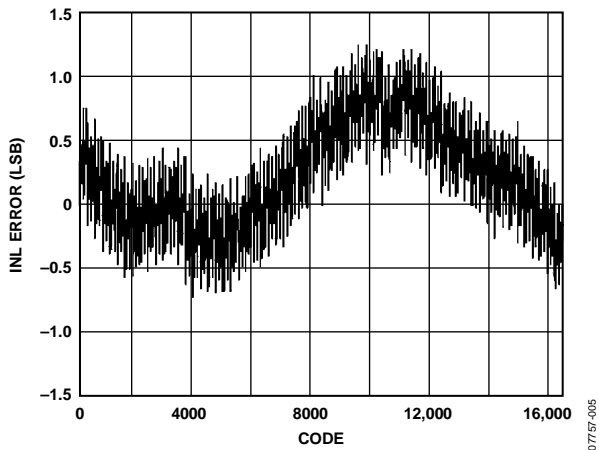

Figure 6. Typical INL

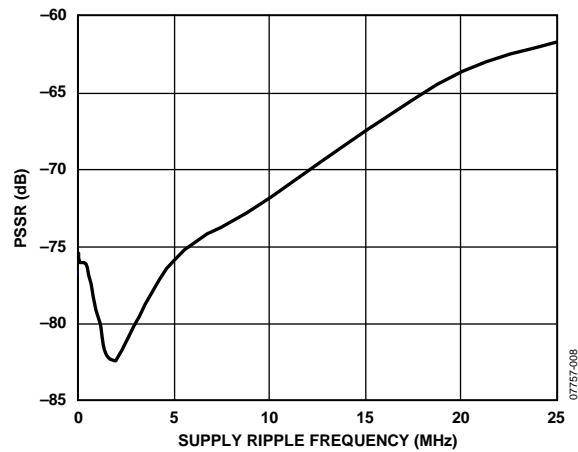

Figure 9. PSRR vs. Supply Ripple Frequency with No Supply Decoupling

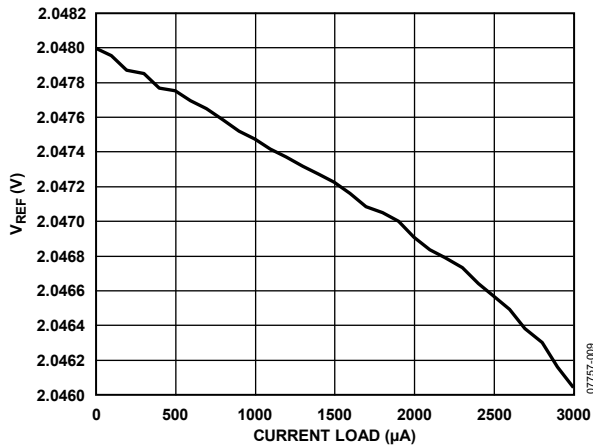

Figure 10. V_{REF} vs. Reference Output Current Drive

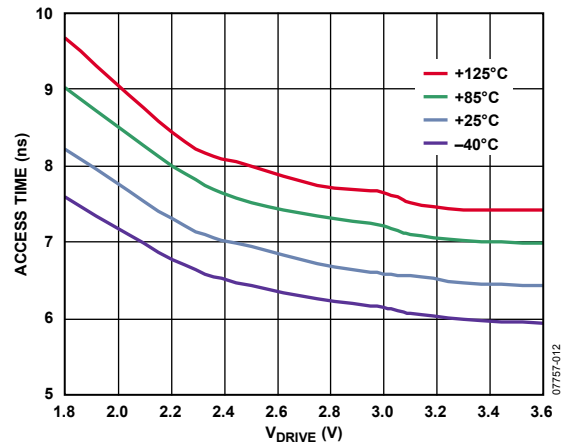

Figure 13. Access Time vs. V_{DRIVE}

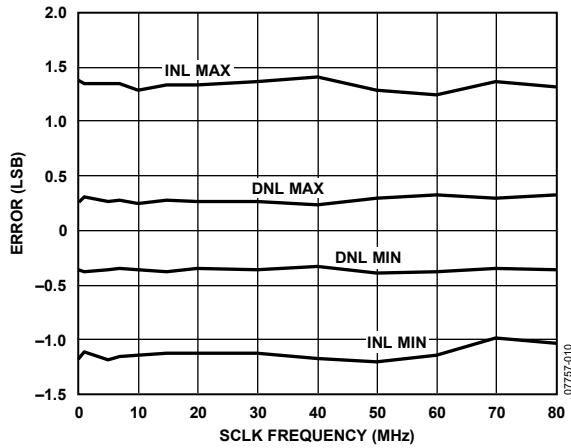

Figure 11. Linearity Error vs. SCLK Frequency

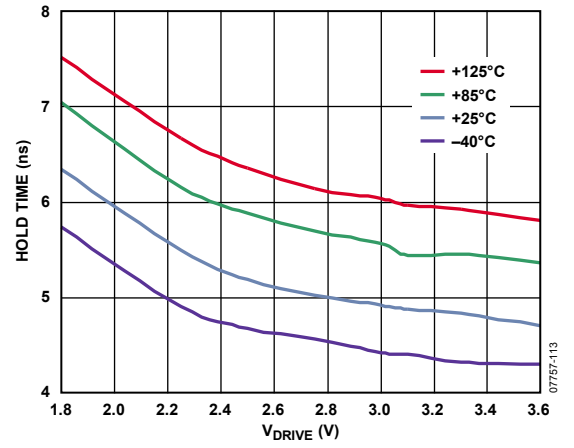

Figure 14. Hold Time vs. V_{DRIVE}

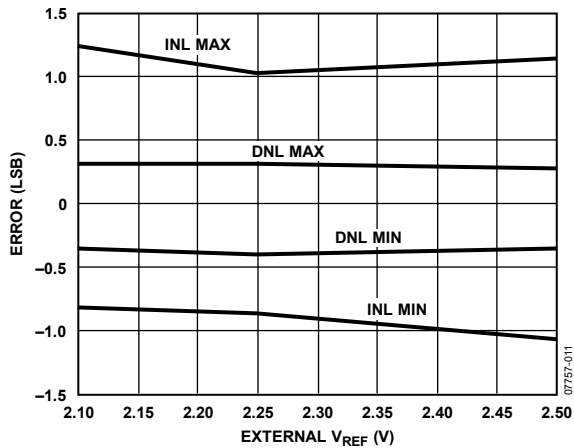

Figure 12. Linearity Error vs. External V_{REF}

TERMINOLOGY

Integral Nonlinearity (INL)

INL is the maximum deviation from a straight line passing through the endpoints of the ADC transfer function. The endpoints of the transfer function are zero scale (1 LSB below the first code transition) and full scale (1 LSB above the last code transition).

Differential Nonlinearity (DNL)

DNL is the difference between the measured and the ideal 1 LSB change between any two adjacent codes in the ADC.

Negative Full-Scale Error

Negative full-scale error is the deviation of the first code transition (00 ... 000) to (00 ... 001) from the ideal (that is, $-V_{REF} + 0.5$ LSB) after the midscale error has been adjusted out.

Negative Full-Scale Error Match

Negative full-scale error match is the difference in negative full-scale error between the two ADCs.

Midscale Error

Midscale error is the deviation of the midscale code transition (011 ... 111) to (100 ... 000) from the ideal (that is, 0 V).

Midscale Error Match

Midscale error match is the difference in midscale error between the two ADCs.

Positive Full-Scale Error

Positive full-scale error is the deviation of the last code transition (111 ... 110) to (111 ... 111) from the ideal (that is, $V_{REF} - 1.5$ LSB) after the midscale error has been adjusted out.

Positive Full-Scale Error Match

Positive full-scale error match is the difference in positive full-scale error between the two ADCs.

ADC to ADC Isolation

ADC to ADC isolation is a measure of the level of crosstalk between ADC A and ADC B. It is measured by applying a full-scale 1 MHz sine wave signal to one of the two ADCs and applying a full-scale signal of variable frequency to the other ADC. The ADC-to-ADC isolation is the ratio of the power of the 1 MHz signal on the converted ADC to the power of the noise signal on the other ADC that appears in the FFT. The noise frequency on the unselected channel varies from 100 kHz to 2.5 MHz.

Power Supply Rejection Ratio (PSRR)

PSRR is the ratio of the power in the ADC output at full-scale frequency, f , to the power of a 100 mV p-p sine wave applied to the ADC VDD supply of the frequency, f_s . The frequency of the input varies from 5 kHz to 25 MHz.

$$PSRR \text{ (dB)} = 10 \log(P_f/P_{f_s})$$

where:

P_f is the power at frequency, f , in the ADC output.

P_{f_s} is the power at frequency, f_s , in the ADC output.

Common-Mode Rejection Ratio (CMRR)

CMRR is the ratio of the power in the ADC output at full-scale frequency, f , to the power of a 100 mV p-p sine wave applied to the common-mode voltage of V_{IN+} and V_{IN-} of frequency, f_s , as follows:

$$CMRR \text{ (dB)} = 10 \log(P_f/P_{f_s})$$

where:

P_f is the power at frequency, f , in the ADC output.

P_{f_s} is the power at frequency, f_s , in the ADC output.

Track-and-Hold Acquisition Time

The track-and-hold amplifier returns to track mode at the end of a conversion. The track-and-hold acquisition time is the time required for the output of the track-and-hold amplifier to reach its final value, within ± 1 LSB, after the end of conversion.

Signal-to-(Noise + Distortion) Ratio (SINAD)

SINAD is the measured ratio of signal-to-(noise + distortion) at the output of the ADC. The signal is the rms amplitude of the fundamental. Noise is the sum of all nonfundamental signals up to half the sampling frequency ($f_s/2$), excluding dc. The ratio is dependent on the number of quantization levels in the digitization process; the more levels, the smaller the quantization noise.

The theoretical SINAD for an ideal N-bit converter with a sine wave input is given by

$$SINAD = (6.02 N + 1.76) \text{ dB}$$

Thus, for a 12-bit converter, SINAD is 74 dB and for a 14-bit converter, SINAD is 86 dB.

Total Harmonic Distortion (THD)

THD is the ratio of the rms sum of harmonics to the fundamental. For the [AD7357](#), it is defined as

$$THD \text{ (dB)} = -20 \log \frac{\sqrt{V_2^2 + V_3^2 + V_4^2 + V_5^2 + V_6^2}}{V_1}$$

where:

V_1 is the rms amplitude of the fundamental.

V_2 , V_3 , V_4 , V_5 , and V_6 are the rms amplitudes of the second through the sixth harmonics.

Peak Harmonic or Spurious Noise

Peak harmonic or spurious noise is the ratio of the rms value of the next largest component in the ADC output spectrum (up to $f_s/2$ and excluding dc) to the rms value of the fundamental. Normally, the value of this specification is determined by the largest harmonic in the spectrum, but for ADCs where the harmonics are buried in the noise floor, it is a noise peak.

Intermodulation Distortion (IMD)

With inputs consisting of sine waves at two frequencies, f_a and f_b , any active device with nonlinearities creates distortion products at sum and difference frequencies of $m f_a \pm n f_b$ where $m, n = 0, 1, 2, 3$, and so on. Intermodulation distortion terms are those for which neither m nor n are equal to zero. For example, the second-order terms include $(f_a + f_b)$ and $(f_a - f_b)$, while the third-order terms include $(2f_a + f_b)$, $(2f_a - f_b)$, $(f_a + 2f_b)$, and $(f_a - 2f_b)$.

The AD7357 is tested using the CCIF standard where two input frequencies near the top end of the input bandwidth are used. In this case, the second-order terms are usually distanced in frequency from the original sine waves, while the third-order terms are usually at a frequency close to the input frequencies. As a result, the second- and third-order terms are specified separately. The calculation of the intermodulation distortion is as per the THD specification (see Table 2), where it is the ratio of the rms sum of the individual distortion products to the rms amplitude of the sum of the fundamentals expressed in decibels (dB).

Thermal Hysteresis

Thermal hysteresis is the absolute maximum change of the reference output voltage after the device is cycled through temperature from either

$$T_HYS+ = 25^\circ\text{C to } T_{MAX} \text{ to } 25^\circ\text{C}$$

$$T_HYS- = 25^\circ\text{C to } T_{MIN} \text{ to } 25^\circ\text{C}$$

It is expressed in ppm using the following equation:

$$V_{HYS}(\text{ppm}) = \left| \frac{V_{REF}(25^\circ\text{C}) - V_{REF}(T_HYS)}{V_{REF}(25^\circ\text{C})} \right| \times 10^6$$

where:

$V_{REF}(25^\circ\text{C})$ is V_{REF} at 25°C .

$V_{REF}(T_HYS)$ is the maximum change of V_{REF} at T_HYS+ or T_HYS- .

THEORY OF OPERATION

CIRCUIT INFORMATION

The AD7357 is a high speed, dual, 14-bit, single-supply, successive approximation ADC. The device operates from a 2.5 V power supply and features throughput rates up to 4.2 MSPS.

The AD7357 contains two on-chip differential track-and-hold amplifiers, two successive approximation ADCs, and a serial interface with two separate data output pins. The device is housed in a 16-lead TSSOP package or an 18-lead LFCSP package, offering the user considerable space-saving advantages over alternative solutions.

The serial clock input accesses data from the device, but also provides the clock source for each successive approximation ADC. The AD7357 has an on-chip 2.048 V reference. If an external reference is desired, the internal reference can be overdriven with a reference value ranging from $(2.048 \text{ V} + 100 \text{ mV})$ to V_{DD} . If the internal reference is to be used elsewhere in the system, the reference output needs to be buffered first. The differential analog input range for the AD7357 is $V_{CM} \pm V_{REF}/2$.

The AD7357 features power-down options to allow power saving between conversions. The power-down options are implemented via the standard serial interface, as described in the Modes of Operation section.

CONVERTER OPERATION

The AD7357 has two successive approximation ADCs, each based around two capacitive DACs. Figure 15 and Figure 16 show simplified schematics of one of these ADCs in acquisition and conversion phases, respectively. The ADC comprises control logic, an SAR, and two capacitive DACs. In Figure 15 (the acquisition phase), SW3 is closed, SW1 and SW2 are in Position A, the comparator is held in a balanced condition, and the sampling capacitor arrays may acquire the differential signal on the input.

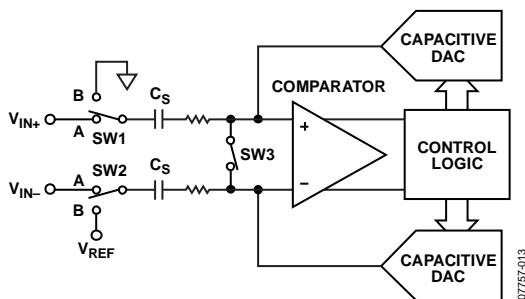

Figure 15. ADC Acquisition Phase

When the ADC starts a conversion (see Figure 16), SW3 opens and SW1 and SW2 move to Position B, causing the comparator to become unbalanced. Both inputs are disconnected when the conversion begins. The control logic and charge redistribution DACs add and subtract fixed amounts of charge from the sampling capacitor arrays to bring the comparator back into a balanced condition. When the comparator is rebalanced, the conversion is complete.

The control logic generates the ADC output code. The output impedances of the sources driving the V_{IN+} and V_{IN-} pins must be matched; otherwise, the two inputs have different settling times, resulting in errors.

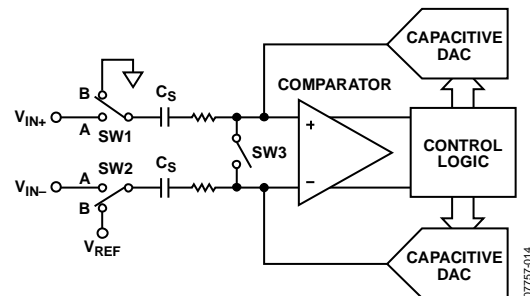

Figure 16. ADC Conversion Phase

ANALOG INPUT STRUCTURE

Figure 17 shows the equivalent circuit of the analog input structure of the AD7357. The four diodes provide ESD protection for the analog inputs. Take care to ensure that the analog input signals never exceed the supply rails by more than 300 mV. Exceeding the limit causes these diodes to become forward-biased and start conducting into the substrate. These diodes can conduct up to 10 mA without causing irreversible damage to the device.

The C1 capacitors in Figure 17 are typically 8 pF and can primarily be attributed to pin capacitance. The R1 resistors are lumped components made up of the on resistance of the switches. The value of these resistors is typically about 30 Ω . The C2 capacitors are the ADC sampling capacitors with a capacitance of 32 pF typically.

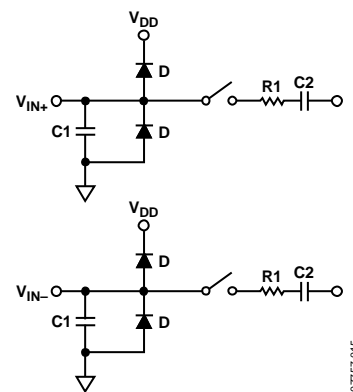

Figure 17. Equivalent Analog Input Circuit Conversion Phase—Switches Open, Track Phase—Switches Closed

For ac applications, it is recommended to remove high frequency components from the analog input signal by the use of an RC low-pass filter on the analog input pins. In applications where harmonic distortion and signal-to-noise ratio are critical, the analog input must be driven from a low impedance source. Large source impedances significantly affect the ac performance of the ADC and may necessitate the use of an input buffer amplifier. The choice of the operational amplifier is a function of the particular application.

When no amplifier drives the analog input, limit the source impedance to low values. The maximum source impedance depends on the amount of THD that can be tolerated. The THD increases as the source impedance increases and performance degrades. Figure 18 shows a graph of the THD vs. the analog input signal frequency for various source impedances.

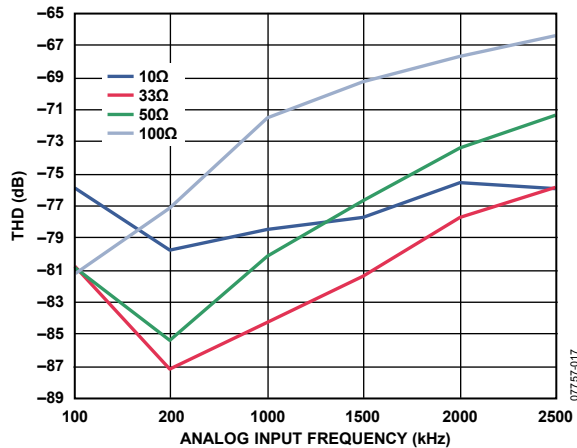

Figure 18. THD vs. Analog Input Frequency for Various Source Impedances

Figure 19 shows a graph of the THD vs. the analog input frequency while sampling at 4.2 MSPS. In this case, the source impedance is 33 Ω.

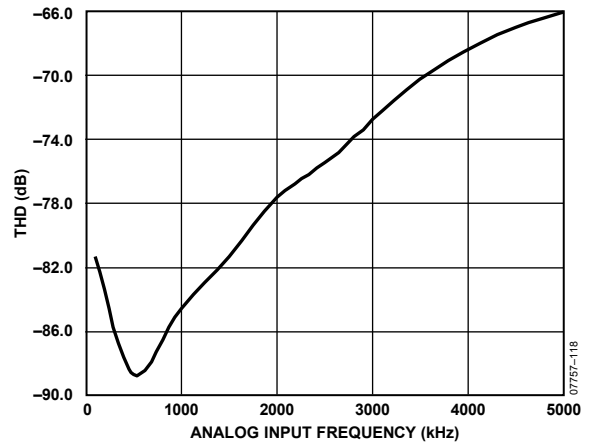
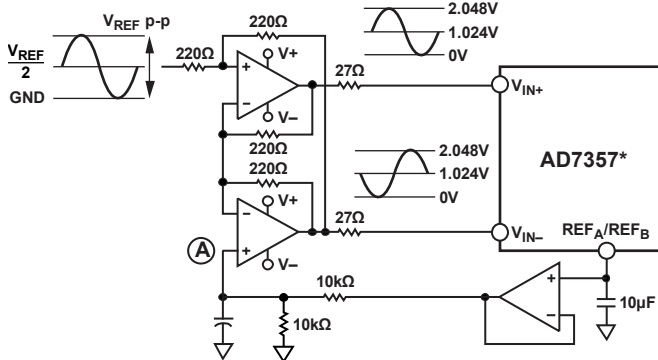

Figure 19. THD vs. Analog Input Frequency

Operational Amplifier Pair

An operational amplifier pair is used to directly couple a differential signal to one of the analog input pairs of the AD7357. The circuit configurations shown in Figure 22 and Figure 23 show how an operational amplifier pair can be used to convert a single-ended signal into a differential signal for a bipolar and unipolar input signal, respectively. The voltage applied to Point A sets up the common-mode voltage. In both diagrams, Point A is connected in some way to the reference. The AD8022 is a suitable dual operational amplifier that is used in this configuration to provide differential drive to the AD7357.



*ADDITIONAL PINS OMITTED FOR CLARITY.

Figure 22. Dual Operational Amplifier Circuit to Convert a Single-Ended Unipolar Signal into a Differential Signal

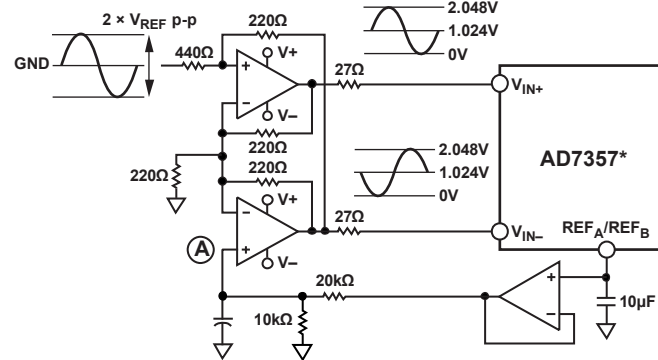

*ADDITIONAL PINS OMITTED FOR CLARITY.

Figure 23. Dual Operational Amplifier Circuit to Convert a Single-Ended Bipolar Signal into a Differential Unipolar Signal

VOLTAGE REFERENCE

The AD7357 allows the choice of a very low temperature drift internal voltage reference or an external reference. The internal 2.048 V reference of the AD7357 provides excellent performance and can be used in almost all applications.

When the internal reference is used, the reference voltage is present on the REF_A and REF_B pins. Decouple these pins to REFGND with 10 μF capacitors. The internal reference voltage can be used elsewhere in the system, provided it is buffered externally.

The REF_A and REF_B pins can also be overdriven with an external voltage reference if desired. The applied reference voltage can range from 2.048 V + 100 mV to V_{DD}. A common choice is to use an external 2.5 V reference such as the ADR441 or ADR431.

ADC TRANSFER FUNCTION

The output coding for the AD7357 is straight binary. The designed code transitions occur at successive LSB values (such as 1 LSB or 2 LSB). The LSB size is (2 × V_{REF})/16,384. The ideal transfer characteristic of the AD7357 is shown in Figure 24.

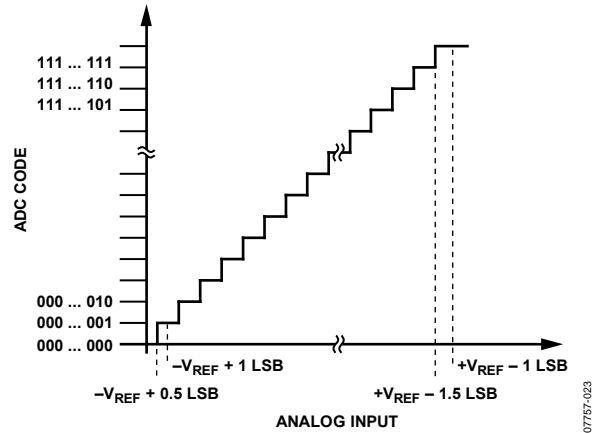

Figure 24. Ideal Transfer Characteristic

MODES OF OPERATION

The **AD7357** mode of operation is selected by controlling the logic state of the \overline{CS} signal during a conversion. There are three possible modes of operation: normal mode, partial power-down mode, and full power-down mode. After a conversion is initiated, the point at which \overline{CS} is pulled high determines which power-down mode, if any, the device enters. Similarly, if already in a power-down mode, \overline{CS} can control whether the device returns to normal operation or remains in a power-down mode. These modes of operation are designed to provide flexible power management options. These options can be chosen to optimize the power dissipation and throughput rate ratio for the differing application requirements.

NORMAL MODE

Normal mode is intended for applications needing the fastest throughput rates. The user does not need to worry about any power-up times because the **AD7357** remains fully powered at all times. Figure 25 shows the general diagram of the operation of the **AD7357** in this mode.

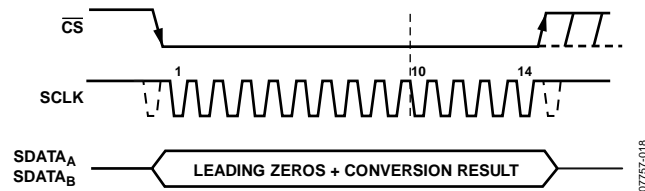

Figure 25. Normal Mode Operation

The conversion is initiated on the falling edge of \overline{CS} , as described in the Serial Interface section. To ensure that the device remains fully powered up at all times, \overline{CS} must remain low until at least 10 SCLK falling edges have elapsed after the falling edge of \overline{CS} . If \overline{CS} is brought high any time after the 10th SCLK falling edge but before the 16th SCLK falling edge, the device remains powered up, but the conversion is terminated and SDATA_A and SDATA_B go back into three-state. To complete the conversion and access the conversion result for the **AD7357**, 16 serial clock cycles are required. SDATA lines do not return to three-state after 16 SCLK cycles have elapsed, but instead do so when \overline{CS} is brought high again. If \overline{CS} is left low for another 2 SCLK cycles, two trailing zeros are clocked out after the data. If \overline{CS} is left low for a further 16 SCLK cycles, the result for the other ADC on board is also accessed on the same SDATA line as shown in Figure 32 (see the Serial Interface section).

When 32 SCLK cycles have elapsed, the SDATA line returns to three-state on the 32nd SCLK falling edge. If \overline{CS} is brought high prior to this, the SDATA line returns to three-state at that point. Thus, \overline{CS} may idle low after 32 SCLK cycles until it is brought high again sometime prior to the next conversion, if so desired, because the bus still returns to three-state upon completion of the dual result read.

When a data transfer is complete and SDATA_A and SDATA_B have returned to three-state, another conversion can be initiated after the quiet time, t_{QUIET} , has elapsed by bringing \overline{CS} low again (assuming the required acquisition time has been allowed).

PARTIAL POWER-DOWN MODE

This mode is intended for use in applications where slower throughput rates are required. Either the ADC is powered down between each conversion or a series of conversions can be performed at a high throughput rate and the ADC is then powered down for a relatively long duration between these bursts of several conversions. When the **AD7357** is in partial power-down mode, all analog circuitry is powered down except for the on-chip reference and reference buffers.

To enter partial power-down mode, interrupt the conversion process by bringing \overline{CS} high anywhere after the second falling edge of SCLK and before the 10th falling edge of SCLK, as shown in Figure 26. When \overline{CS} is brought high in this window of SCLKs, the device enters partial power-down mode, the conversion that was initiated by the falling edge of \overline{CS} is terminated, and SDATA_A and SDATA_B go back into three-state. If \overline{CS} is brought high before the second SCLK falling edge, the device remains in normal mode and does not power down. This avoids accidental power-down due to glitches on the \overline{CS} line.

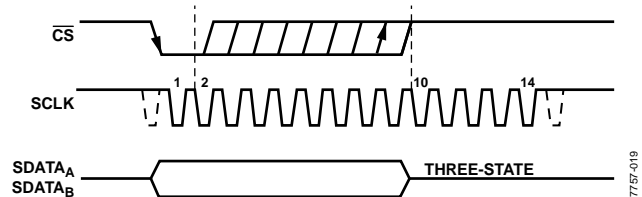

Figure 26. Entering Partial Power-Down Mode

To exit this mode of operation and to power up the **AD7357** again, perform a dummy conversion. On the falling edge of \overline{CS} , the device begins to power up and continues to power up as long as \overline{CS} is held low until after the falling edge of the 10th SCLK. The device is fully powered up after approximately 200 ns elapses (or one full conversion), and valid data results from the next conversion, as shown in Figure 27. If \overline{CS} is brought high before the second falling edge of SCLK, the **AD7357** again goes into partial power-down mode. This avoids accidental power-up due to glitches on the \overline{CS} line. Although the device may begin to power up on the falling edge of \overline{CS} , it powers down again on the rising edge of \overline{CS} . If the **AD7357** is already in partial power-down mode and \overline{CS} is brought high between the second and 10th falling edges of SCLK, the device enters full power-down mode.

FULL POWER-DOWN MODE

This mode is intended for use in applications where throughput rates slower than those in the partial power-down mode are required, as power-up from a full power-down takes substantially longer than from a partial power-down. This mode is more suited to applications where a series of conversions performed at a relatively high throughput rate are followed by a long period of inactivity and, thus, power-down. When the AD7357 is in full power-down, all analog circuitry is powered down. Full power-down is entered in a way that is similar to partial power-down, except that the timing sequence shown in Figure 26 must be executed twice. The conversion process must be interrupted in a similar fashion by bringing \overline{CS} high anywhere after the second falling edge of SCLK and before the 10th falling edge of SCLK. The device enters partial power-down mode at this point.

To reach full power-down, the next conversion cycle must be interrupted in the same way, as shown in Figure 28. When \overline{CS} has been brought high in this window of SCLKs, the device completely powers down.

Note that it is not necessary to complete the 16 SCLK pulses after \overline{CS} has been brought high to enter a power-down mode.

To exit full power-down mode and power up the AD7357, perform a dummy conversion, such as powering up from partial power-down. On the falling edge of \overline{CS} , the device begins to power up, as long as \overline{CS} is held low until after the falling edge of the 10th SCLK. The required power-up time must elapse before a conversion can be initiated, as shown in Figure 29.

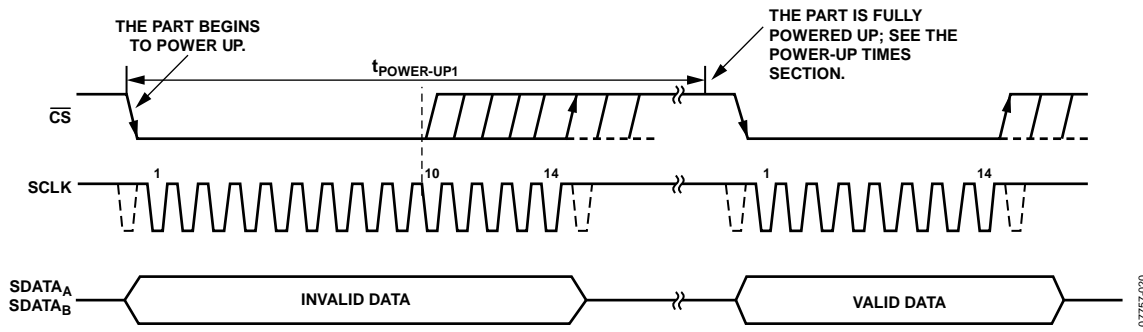

Figure 27. Exiting Partial Power-Down Mode

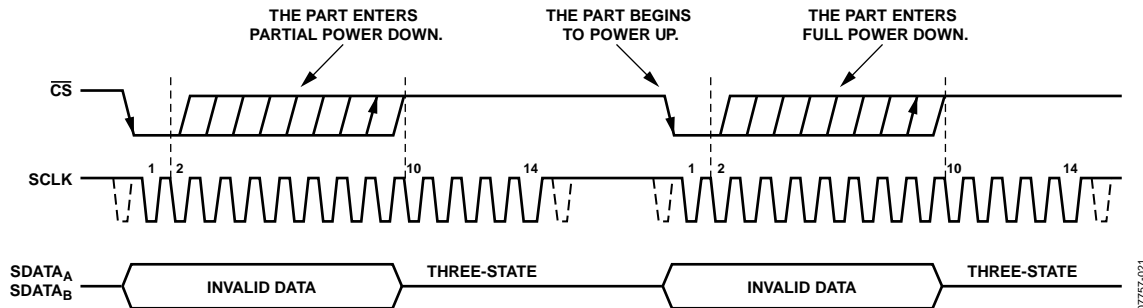

Figure 28. Entering Full Power-Down Mode

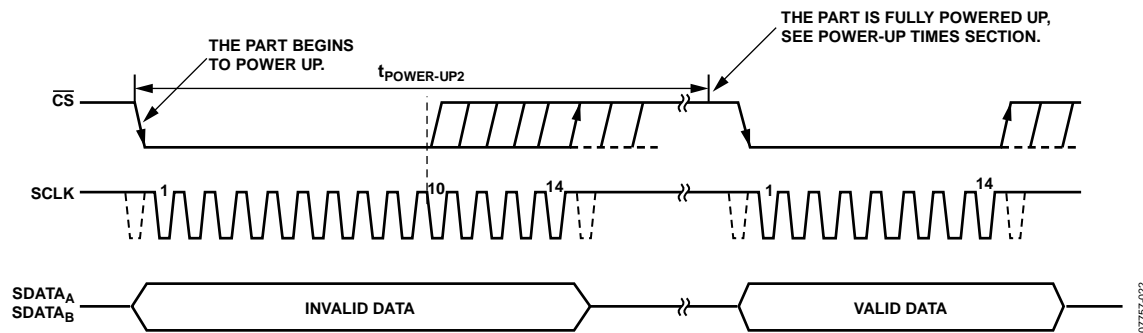

Figure 29. Exiting Full Power-Down Mode

POWER-UP TIMES

The AD7357 has two power-down modes: partial power-down and full power-down. They are described in detail in the Partial Power-Down Mode section and the Full Power-Down Mode section. This section describes the power-up time required when coming out of either of these modes. Note that the power-up times apply with the recommended decoupling capacitors in place on the REF_A and REF_B pins.

To power up from partial power-down mode, one dummy cycle is required. The device is fully powered up after approximately 200 ns from the falling edge of CS has elapsed. As soon as the partial power-up time has elapsed, the ADC is fully powered up and the input signal is acquired properly. The quiet time, t_{QUIET} , must still be allowed from the point where the bus goes back into three-state after the dummy conversion to the next falling edge of CS.

To power up from full power-down, allow approximately 6 ms from the falling edge of CS, shown in Figure 29 as $t_{\text{POWER-UP2}}$.

Note that during power-up from partial power-down mode, the track-and-hold, which is in hold mode while the device is powered down, returns to track mode after the first SCLK edge that the device receives after the falling edge of CS.

When power supplies are first applied to the AD7357, the ADC powers up in either of the power-down modes or in normal mode. Because of this, it is best to allow a dummy cycle to elapse to ensure that the device is fully powered up before attempting a valid conversion. Likewise, if the device is kept in partial power-down mode immediately after the supplies are applied, then initiate two dummy cycles. The first dummy cycle must hold CS low until after the 10th SCLK falling edge; in the second cycle, CS must be brought high between the second and 10th SCLK falling edges (see Figure 26).

Alternatively, if the device is placed into full power-down mode when the supplies are applied, three dummy cycles must be initiated. The first dummy cycle must hold CS low until after the 10th SCLK falling edge; the second and third dummy cycles place the device into full power-down mode (see Figure 28 and the Modes of Operation section).

POWER vs. THROUGHPUT RATE

The power consumption of the AD7357 varies with the throughput rate. When using very slow throughput rates and as fast an SCLK frequency as possible, the various power-down options can be used to make significant power savings. However, the AD7357 quiescent current is low enough that even without using the power-down options, there is a noticeable variation in power consumption with sampling rate. This is true whether a fixed SCLK value is used or if it is scaled with the sampling rate. Figure 30 shows a plot of power vs. throughput rate when operating in normal mode for a fixed maximum SCLK frequency and an SCLK frequency that scales with the sampling rate. The internal reference is used for Figure 30.

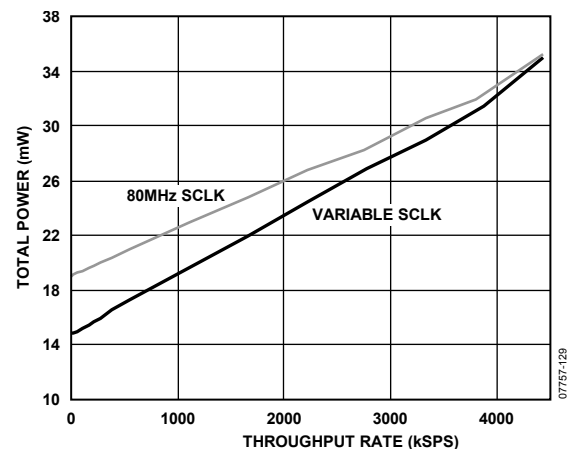

Figure 30. Total Power vs. Throughput Rate

SERIAL INTERFACE

Figure 31 shows the detailed timing diagram for serial interfacing to the AD7357. The serial clock (SCLK) provides the conversion clock and controls the transfer of information from the AD7357 during conversion. There is a single sample delay in the result that is clocked out from the AD7357.

The \overline{CS} signal initiates the data transfer and conversion process. The falling edge of \overline{CS} puts the track-and-hold into hold mode. At this point, the analog input is sampled and the bus is taken out of three-state. The conversion is also initiated and requires a minimum of 16 SCLKs to complete. When 16 SCLK falling edges have elapsed, the track-and-hold goes back into track on the next SCLK rising edge, as shown in Figure 31 at Point B. On the rising edge of \overline{CS} , the conversion is terminated and $SDATA_A$ and $SDATA_B$ go back into three-state. If \overline{CS} is not brought high but is, instead, held low for an additional 16 SCLK cycles on $SDATA_A$, the data from the conversion on ADC B is output on $SDATA_A$.

Likewise, if \overline{CS} is held low for an additional 16 SCLK cycles on $SDATA_A$, the data from the conversion on ADC A is output on $SDATA_B$ (see Figure 32). In this case, the $SDATA$ line in use goes back into three-state on the 32nd SCLK falling edge or the rising edge of \overline{CS} , whichever occurs first.

A minimum of 16 SCLK cycles are required to perform the conversion process and to access data from one conversion on either data line of the AD7357. Note that the data accessed on $SDATA_A$ and $SDATA_B$ is the result of the previous conversion. \overline{CS} going low provides the leading zero to be read in by the microcontroller or DSP. The remaining data is then clocked out by subsequent SCLK falling edges, beginning with a second leading zero. Thus, the first falling clock edge on the serial clock has the leading zero provided and clocks out the second leading zero. The 14-bit result then follows with the final bit in the data transfer valid on the 16th falling edge, having been clocked out on the previous (15th) falling edge. In applications with a slower SCLK, it may be possible to read in data on each SCLK rising edge depending on the SCLK frequency. The first rising edge of SCLK after the \overline{CS} falling edge has the second leading zero provided and the 15th rising SCLK edge has DB_0 provided.

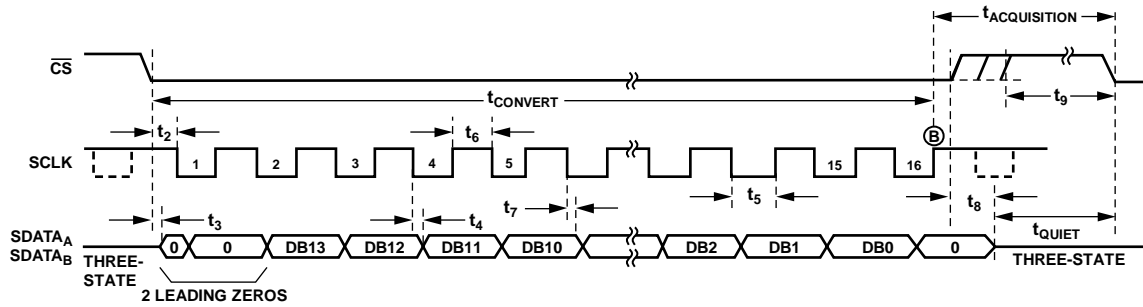

Figure 31. Serial Interface Timing Diagram

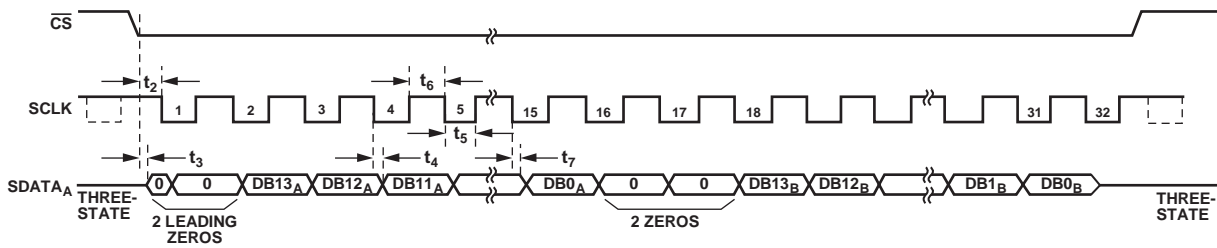

Figure 32. Reading Data from Both ADCs on One SDATA Line with 32 SCLKs

APPLICATION SUGGESTIONS

GROUNDING AND LAYOUT

The analog and digital supplies to the [AD7357](#) are independent and separately pinned out to minimize coupling between the analog and digital sections of the device. The PCB that houses the [AD7357](#) must be designed so that the analog and digital sections are separated and confined to certain areas of the board. This design facilitates the use of easily separated ground planes.

To provide optimum shielding for ground planes, a minimum etch technique is generally best. Sink the two AGND pins of the [AD7357](#) in the AGND plane. Join the digital and analog ground plans in only one place. If the [AD7357](#) is in a system where multiple devices require an AGND and DGND connection, still make the connection at one point only. Establish a star ground point as close as possible to the ground pins on the [AD7357](#).

Avoid running digital lines under the device because this couples noise onto the die. Allow the analog ground planes to run under the [AD7357](#) to avoid noise coupling. The power supply lines to the [AD7357](#) must use as large a trace as possible to provide low impedance paths and reduce the effects of glitches on the power supply line.

To avoid radiating noise to other sections of the board, shield fast switching signals, such as clocks with digital ground, and never run clock signals near the analog inputs. Avoid crossover of digital and analog signals. To reduce the effects of feedthrough within the board, run traces on opposite sides of the board at right angles to each other. A microstrip technique is the best method, but it is not always possible with a double-sided board. In this technique, the component side of the board is dedicated to ground planes, while signals are placed on the solder side.

Good decoupling is important; decouple all supplies with 10 μF tantalum capacitors parallel with 0.1 μF capacitors to GND. To achieve the best results from these decoupling components, place them as close as possible to the device, ideally right up against the device. The 0.1 μF capacitor must have low effective series resistance (ESR) and effective series inductance (ESI), such as the common ceramic types or surface-mount types. These low ESR and ESI capacitors provide a low impedance path to ground at high frequencies to handle transient currents due to logic switching.

EVALUATING THE [AD7357](#) PERFORMANCE

The recommended layout for the [AD7357](#) is outlined in evaluation board documentation. The evaluation board package includes a fully assembled and tested evaluation board, documentation, and software for controlling the board from the PC via the converter evaluation and development board (CED). The CED can be used in conjunction with the [AD7357](#) evaluation board (as well as many other evaluation boards ending in the ED designator from Analog Devices, Inc.) to demonstrate and evaluate the ac and dc performance of the [AD7357](#).

The software allows the user to perform ac (fast Fourier transform) and dc (linearity) tests on the [AD7357](#). The software and documentation are on a CD that is shipped with the evaluation board.

OUTLINE DIMENSIONS

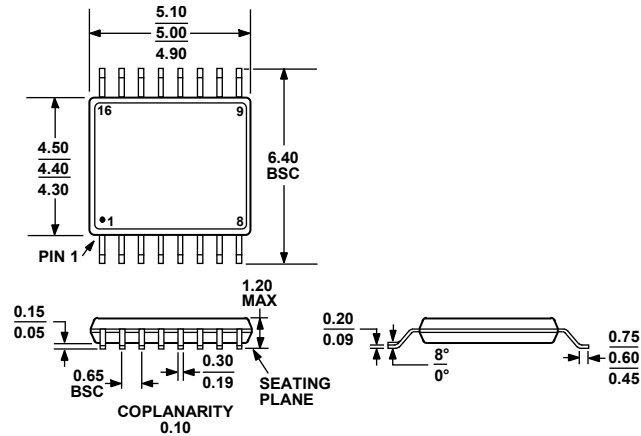

COMPLIANT TO JEDEC STANDARDS MO-153-AB

Figure 33. 16-Lead Thin Shrink Small Outline Package [TSSOP] (RU-16)

Dimensions shown in millimeters

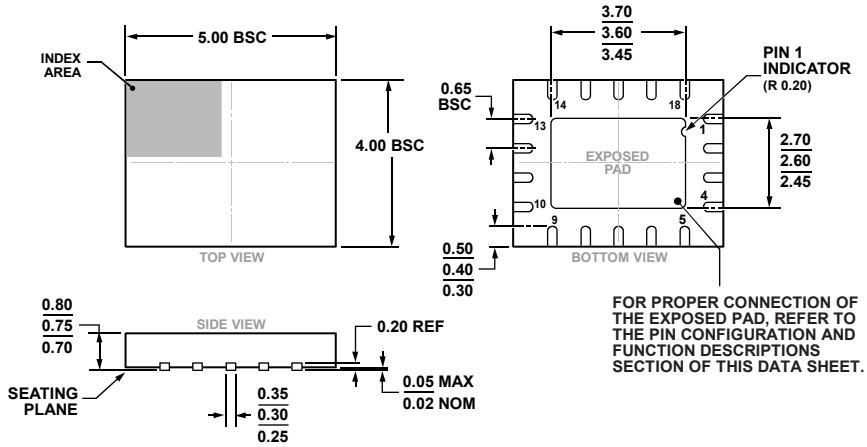

FOR PROPER CONNECTION OF THE EXPOSED PAD, REFER TO THE PIN CONFIGURATION AND FUNCTION DESCRIPTIONS SECTION OF THIS DATA SHEET.

Figure 34. 18-Lead Lead Frame Chip Scale Package [LF CSP_WQ] 5mm x 4 mm Body, Very Very Thin Quad (CP-18-1)

Dimensions shown in millimeters

ORDERING GUIDE

Model ^{1, 2, 3, 4}	Temperature Range	Package Description	Package Option
AD7357BCPZ	−40°C to +125°C	18-Lead Lead Frame Chip Scale Package [LFCSP_WQ]	CP-18-1
AD7357BCPZ-RL	−40°C to +125°C	18-Lead Lead Frame Chip Scale Package [LFCSP_WQ]	CP-18-1
AD7357BRUZ	−40°C to +85°C	16-Lead Thin Shrink Small Outline Package [TSSOP]	RU-16
AD7357BRUZ-500RL7	−40°C to +85°C	16-Lead Thin Shrink Small Outline Package [TSSOP]	RU-16
AD7357BRUZ-RL	−40°C to +85°C	16-Lead Thin Shrink Small Outline Package [TSSOP]	RU-16
AD7357YRUZ	−40°C to +125°C	16-Lead Thin Shrink Small Outline Package [TSSOP]	RU-16
AD7357YRUZ-500RL7	−40°C to +125°C	16-Lead Thin Shrink Small Outline Package [TSSOP]	RU-16
AD7357YRUZ-RL	−40°C to +125°C	16-Lead Thin Shrink Small Outline Package [TSSOP]	RU-16
AD7357WYRUZ	−40°C to +125°C	16-Lead Thin Shrink Small Outline Package [TSSOP]	RU-16
AD7357WYRUZ-RL	−40°C to +125°C	16-Lead Thin Shrink Small Outline Package [TSSOP]	RU-16
EVAL-AD7357EDZ		Evaluation Board	
EVAL-CED1Z		Converter Evaluation and Development Board	

¹ Z = RoHS Compliant Part.

² W = Qualified for Automotive Applications.

³ The EVAL-AD7357EDZ can be used as a standalone evaluation board or in conjunction with the EVAL-CED1Z board for evaluation/demonstration purposes.

⁴ The EVAL-CED1Z is a complete unit allowing a PC to control and communicate with all Analog Devices evaluation boards ending in the ED designator.

AUTOMOTIVE PRODUCTS

The AD7357W models are available with controlled manufacturing to support the quality and reliability requirements of automotive applications. Note that these automotive models may have specifications that differ from the commercial models; therefore, designers should review the Specifications section of this data sheet carefully. Only the automotive grade products shown are available for use in automotive applications. Contact your local Analog Devices account representative for specific product ordering information and to obtain the specific Automotive Reliability reports for these models.

Looking for pricing, stock, or lifecycle information?

Click below to explore more details on WIN SOURCE:

⊖ [View AD7357YRUZ-500RL7 on WIN SOURCE](#)

⊖ [Analog Devices Inc. Information](#)

Optimize Your Supply Chain with WIN SOURCE Solutions

- ✓ Global Sourcing Solution
- ✓ Obsolete Management
- ✓ Cost Control Management
- ✓ Shortage Management
- ✓ Alternative Solution
- ✓ Excess Inventory Management